

ACX7100-48L Cloud Metro Router Hardware Guide

Published
2025-01-13

Juniper Networks, Inc.
1133 Innovation Way
Sunnyvale, California 94089
USA
408-745-2000
www.juniper.net

Juniper Networks, the Juniper Networks logo, Juniper, and Junos are registered trademarks of Juniper Networks, Inc. in the United States and other countries. All other trademarks, service marks, registered marks, or registered service marks are the property of their respective owners.

Juniper Networks assumes no responsibility for any inaccuracies in this document. Juniper Networks reserves the right to change, modify, transfer, or otherwise revise this publication without notice.

ACX7100-48L Cloud Metro Router Hardware Guide
Copyright © 2025 Juniper Networks, Inc. All rights reserved.

The information in this document is current as of the date on the title page.

YEAR 2000 NOTICE

Juniper Networks hardware and software products are Year 2000 compliant. Junos OS has no known time-related limitations through the year 2038. However, the NTP application is known to have some difficulty in the year 2036.

END USER LICENSE AGREEMENT

The Juniper Networks product that is the subject of this technical documentation consists of (or is intended for use with) Juniper Networks software. Use of such software is subject to the terms and conditions of the End User License Agreement ("EULA") posted at <https://support.juniper.net/support/eula/>. By downloading, installing or using such software, you agree to the terms and conditions of that EULA.

Table of Contents

About This Guide | ix

1

Fast Track: Initial Installation

Fast Track to Rack Installation and Power | 2

Install the ACX7100-48L in a Rack | 2

Connect to Power | 3

Onboard, Configure, and Monitor ACX7100-48L | 5

2

Overview

ACX7100-48L System Overview | 8

ACX7100-48L Router Description | 8

ACX7100-48L Router Models | 10

Field-Replaceable Units in ACX7100-48L Routers | 11

Hardware Redundancy of ACX7100-48L Router Components and Functionality | 12

ACX7100-48L Routers Hardware and CLI Terminology Mapping | 12

ACX7100-48L System Software Overview | 14

ACX7100-48L Chassis | 15

Management Panel of ACX7100-48L Routers | 15

Management Port LEDs on ACX7100-48L Routers | 16

Port Panel of ACX7100-48L Routers | 17

Network Port LEDs on ACX7100-48L Routers | 22

Chassis Status LEDs on ACX7100-48L Routers | 24

Cooling System and Airflow in ACX7100-48L Routers | 27

ACX7100-48L Power System | 32

AC Power Supply for ACX7100-48L Routers | 33

AC Power Specifications for ACX7100-48L Routers | 34

- AC Power Cord Specifications for ACX7100-48L Routers | 35
- AC Power Supply Module LEDs on ACX7100-48L Routers | 37
- DC Power Supply for ACX7100-48L Routers | 38
- DC Power Specifications for ACX7100-48L Routers | 39
- DC Power Supply Module LEDs on ACX7100-48L Routers | 40

Site Planning, Preparation, and Specifications

Site Preparation Checklist for ACX7100-48L Routers | 43

ACX7100-48L Site Guidelines and Requirements | 44

- General Site Guidelines | 45
- Site Electrical Wiring Guidelines | 45
- Chassis Physical Specifications for ACX7100-48L Routers | 46
- Environmental Requirements and Specifications for ACX7100-48L Routers | 47
- Grounding Cable and Lug Specifications for ACX7100-48L | 48
- Clearance Requirements for Hardware Maintenance of ACX7100-48L Routers | 49
- Rack Requirements for ACX7100-48L Routers | 50
- Cabinet Requirements for ACX7100-48L Routers | 52

ACX7100-48L Network Cable and Transceiver Planning | 54

- Determining Transceiver Support for ACX7100-48L | 54
- Cable and Connector Specifications for ACX7100-48L | 55
- Calculating Power Budget and Power Margin for Fiber-Optic Cables | 62
 - Calculate Power Budget for Fiber-Optic Cables | 63
 - How to Calculate Power Margin for Fiber-Optic Cables | 63
- Fiber-Optic Cable Signal Loss, Attenuation, and Dispersion | 65

ACX7100-48L Management and Console Port Specifications and Pinouts | 66

- Management Cable Specifications for ACX7100 Routers | 67
- Management Port Connector Pinout Information for ACX7100 | 67
- Console Port Connector Pinout on ACX7100 Routers | 68

USB Port Specifications for ACX7100 | 69

Initial Installation and Configuration

ACX7100-48L Installation Overview | 72

Unpack and Mount an ACX7100-48L Router | 72

Unpack an ACX7100-48L Router | 72

Register Products—Mandatory to Validate SLAs | 74

Mount an ACX7100-48L Router in a Rack | 74

Before You Begin Rack Installation | 75

Install an ACX7100-48L Router in a Rack | 76

Mount an ACX7100-48L Router in a Rack or Cabinet by Using the JNP-4PST-RMK-1U-E Rack Mount Kit | 78

Mount the Device by Using the JNP-4PST-RMK-1U-E Rack Mount Kit On a Square Hole Rack | 79

Mount the Device by Using the JNP-4PST-RMK-1U-E Rack Mount Kit On a Threaded Hole Rack | 83

Connect ACX7100-48L to Power | 89

Connect Earth Ground to ACX7100-48L Routers | 90

Connect Earth Ground to ACX7100-48L Routers | 90

Connect Earth Ground to DC PSM Protective Earthing Terminal | 92

Connect AC Power to an ACX7100-48L Router | 93

Connect DC Power to an ACX7100-48L Router | 95

Connect ACX7100-48L to External Devices | 99

Connect an ACX7100-48L Router to a Management Console | 99

Connect an ACX7100-48L Router to a Network for Out-of-Band Management | 101

Connect an ACX7100-48L Router to External Clocking and Timing Devices | 102

Perform Initial Software Configuration for the ACX7100-48L Routers | 103

Maintaining Components

Maintaining the ACX7100-48L Fan Modules | 108

Remove a Fan Module from an ACX7100-48L Router | 108

Install a Fan Module in an ACX7100-48L Router | 109

Maintaining the ACX7100-48L Power Supplies | 111

Replace an ACX7100-48L AC Power Supply Module | 111

Remove an AC Power Supply Module from an ACX7100-48L Router | 112

Install an AC Power Supply Module in an ACX7100-48L Router | 113

Replace an ACX7100-48L DC Power Supply Module | 115

Remove an ACX7100-48L DC Power Supply Module | 115

Install an ACX7100-48L DC Power Supply Module | 117

Maintain the ACX7100-48L Transceivers and Fiber-Optic Cables | 119

Remove a Transceiver | 120

Install a Transceiver | 122

Remove a QSFP28 Transceiver | 124

Install a QSFP28 Transceiver | 126

How to Connect a Fiber-Optic Cable from a Transceiver on a ACX7100-48L Router | 127

How to Disconnect a Fiber-Optic Cable from a Transceiver on a ACX7100-48L Router | 127

How to Maintain Fiber-Optic Cable for an ACX7100-48L Router | 128

Maintaining SATA Solid State Drive in an ACX7100-48L | 129

Removing a SATA Solid State Drive from an ACX7100-48L | 129

Installing a SATA Solid State Drive in an ACX7100-48L | 131

Uninstall the ACX7100-48L Router | 132

Power Off an ACX7100-48L Router | 133

Remove an ACX7100-48L Router from a Rack or Cabinet | 134

6

Troubleshooting Hardware

Troubleshooting the ACX7100-48L Router | 137

Alarm Types and Severity Classes on ACX Series Routers | 137

7

Contacting Customer Support and Returning the Chassis or Components

Contacting Customer Support and Returning the Chassis or Components | 140

How to Return a Hardware Component to Juniper Networks, Inc. | 140

How to Locate the Serial Number on an ACX7100-48L Router or Component | 141

List the Chassis and Component Details Using the CLI | 141

Locate the Chassis Serial Number ID Label on an ACX7100-48L Router | 143

Locate the Serial Number ID Labels on ACX7100-48L Power Supply Modules | 144

Locate the Serial Number ID Label on an ACX7100-48L Fan Module | 145

Contact Customer Support to Obtain Return Material Authorization | 146

Guidelines for Packing Hardware Components for Shipment | 146

8

Safety and Compliance Information

General Safety Guidelines and Warnings | 150

Definitions of Safety Warning Levels | 151

Qualified Personnel Warning | 153

Warning Statement for Norway and Sweden | 153

Fire Safety Requirements | 154

Installation Instructions Warning | 155

Chassis and Component Lifting Guidelines | 156

Restricted Access Warning | 156

Ramp Warning | 158

Rack-Mounting and Cabinet-Mounting Warnings | 158

Grounded Equipment Warning | 162

Radiation from Open Port Apertures Warning | 163

Laser and LED Safety Guidelines and Warnings | 164

Maintenance and Operational Safety Guidelines and Warnings | 167

General Electrical Safety Guidelines and Warnings | 173

Prevention of Electrostatic Discharge Damage | 174

Site Electrical Wiring Guidelines | 176

AC Power Electrical Safety Guidelines | 177

AC Power Disconnection Warning	178
DC Power Disconnection Warning	179
DC Power Grounding Requirements and Warning	180
DC Power Wiring Sequence Warning	181
DC Power Wiring Terminations Warning	183
Multiple Power Supplies Disconnection Warning	184
TN Power Warning	185
Action to Take After an Electrical Accident	185
Agency Approvals for ACX7100 Routers	186
Compliance Statements for Data Center	188
Compliance Statements for EMC Requirements	188
Compliance Statements for Environmental Requirements	190

About This Guide

Use this guide to install hardware and perform initial software configuration, routine maintenance, and troubleshooting for the ACX7100-48L Cloud Metro Router.

After completing the installation and basic configuration procedures covered in this guide, refer to the [Junos OS Evolved documentation](#) for information about further software configuration.

1

CHAPTER

Fast Track: Initial Installation

[Fast Track to Rack Installation and Power | 2](#)

[Onboard, Configure, and Monitor ACX7100-48L | 5](#)

Fast Track to Rack Installation and Power

SUMMARY

This procedure guides you through the simplest steps to install your ACX7100-48L router in a rack and connect it to power.

IN THIS SECTION

- [Install the ACX7100-48L in a Rack | 2](#)
- [Connect to Power | 3](#)

Install the ACX7100-48L in a Rack

You can install an ACX7100-48L router into a four-post rack or a cabinet. We'll walk you through the steps to install an AC-powered ACX7100-48L router in a four-post rack and connect it to power.

Before you install, review the following:

- ["ACX7100-48L Site Guidelines and Requirements" on page 44](#)
 - [General Safety Guidelines and Warnings](#)
1. Wrap and fasten one end of the ESD grounding strap around your bare wrist, and connect the other end to a site ESD point.
 2. Position the router so that the **AIR IN** labels are facing the cold aisle, or the **AIR OUT** labels are facing the hot aisle.
 3. Attach the mounting rails to the sides of the router using the 12 flat head screws.

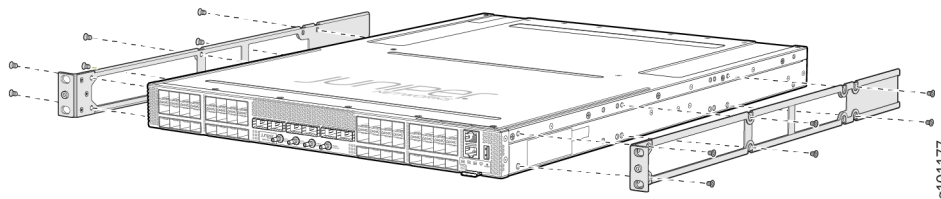

4. Lift the router and position it in the rack. Line up the bottom hole in each mounting rail with a hole in each rack rail, making sure the router is level.
5. While you're holding the router in place, have a second person insert and tighten the rack mount screws to secure the mounting rails to the rack rails. Make sure they tighten the screws in the two bottom holes first, and then tighten the screws in the two top holes.

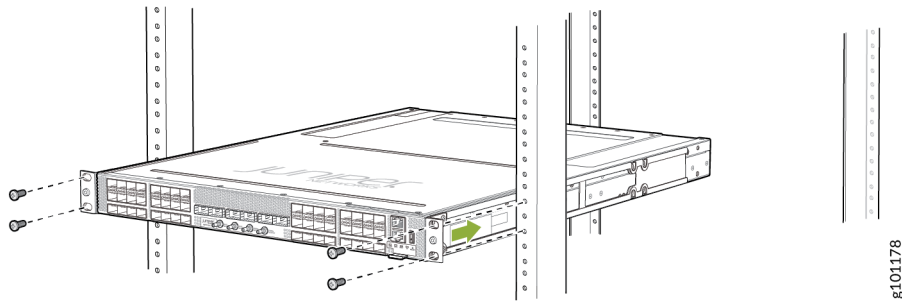

6. Continue holding the router in place, and have the second person slide the mounting blades into the channel of the mounting rails.
7. Secure the mounting blades to the rack using the rack mount screws (and cage nuts and washers, if your rack requires them).

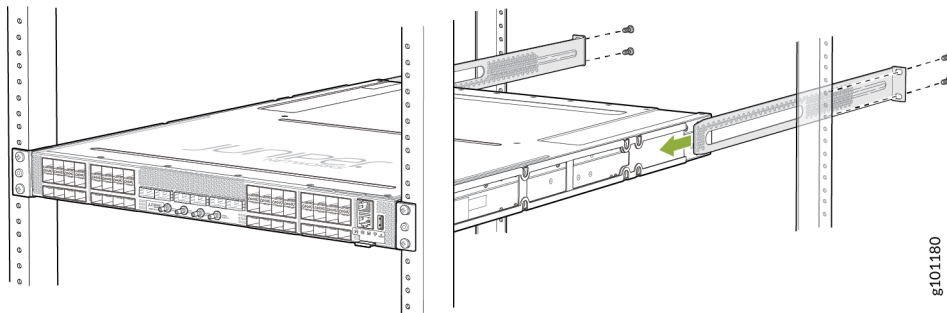

8. Verify that the mounting brackets on each side of the rack are level.



NOTE: If you have unused ports, plug them using dust covers to prevent dust from entering the router.

Connect to Power

Now that you've installed your ACX7100-48L in the rack, you're ready to connect it to power.

The AC-powered ACX7100-48L comes with two AC power supplies preinstalled on the rear panel.

1. Wrap and fasten one end of the ESD grounding strap around your bare wrist, and connect the other end to one of the ESD grounding points on the router.
2. Use two #10-32 screws to secure the grounding lug and attached cable to the chassis. Attach the lug through the left rail and blade assembly to the chassis.

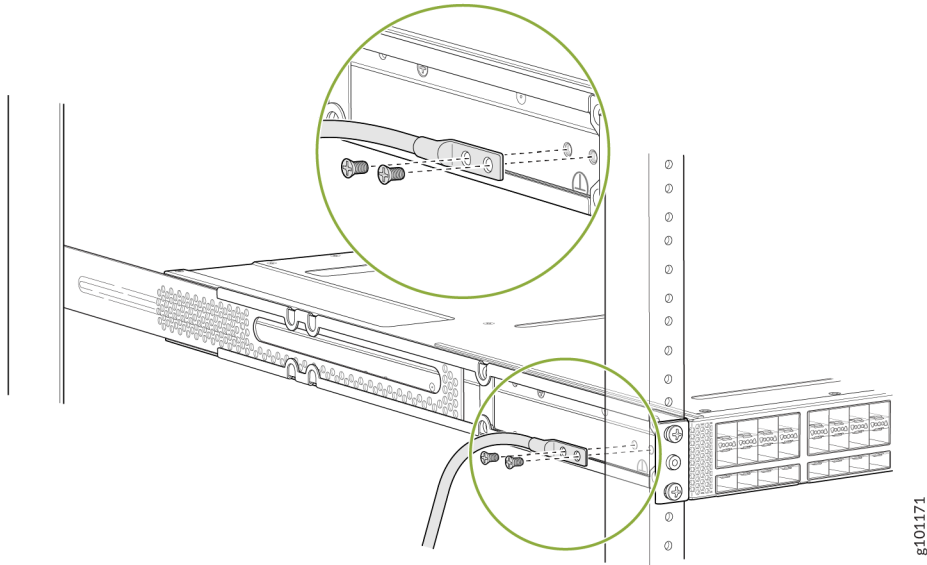

g101171

3. Connect the other end of the grounding cable to a proper earth ground, such as the rack.
4. Dress the grounding cable and ensure that it doesn't touch or block access to other device components, and that it doesn't drape where people could trip over it.
5. Ensure that the power supplies are fully inserted in the chassis and the latches are secure.
6. For each power supply, ensure that the loop on the power cord retainer is open and there's enough space to insert the power cord coupler into the inlet. If the loop is closed, press the small tab on the retainer to loosen the loop.

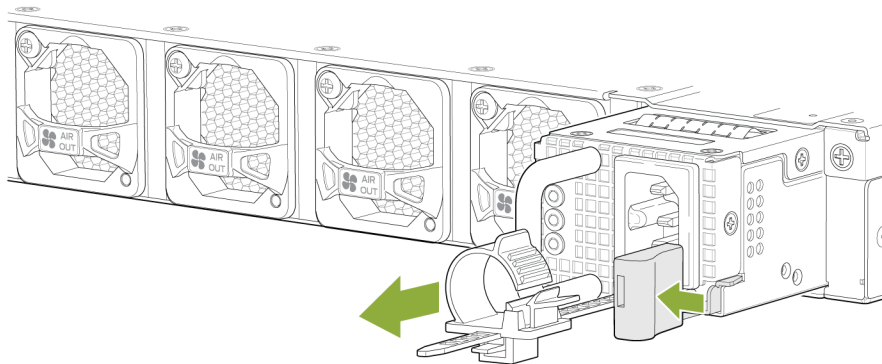

g101161

7. On the first power supply, thread the power cord coupler through the power cord retainer loop.
8. Plug in the power cord to the power supply socket.
9. Slide the power cord retainer loop toward the power supply until the loop is snug against the base of the coupler.
10. Press the tab on the loop, and draw out the loop into a tight circle.

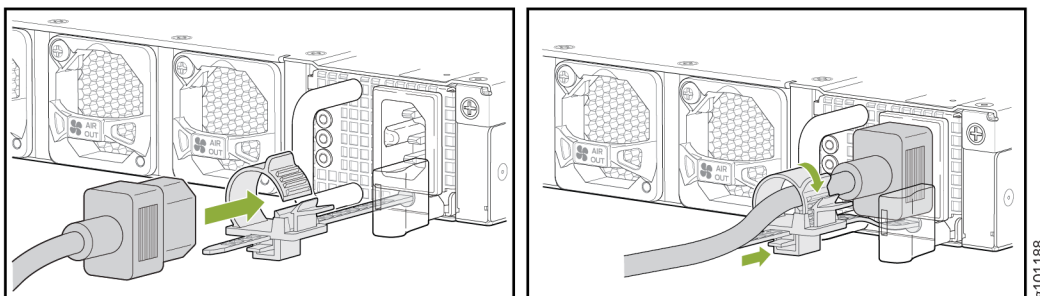

WARNING: Ensure that the power cord does not block access to router components or drape where people can trip on it.

11. If the AC power source outlet has a power switch, turn it off.
12. Plug in the power cord to the AC power source outlet.
13. If the AC power source outlet has a power switch, turn it on.



NOTE: The router powers on as soon as you connect it to power. The ACX7100-48L doesn't have a power switch.

14. Verify that the AC LED on the power supply is lit green. If the LED is lit steadily amber or is blinking amber, disconnect the power supply from the power source, and replace the power supply (see [Maintain the ACX7100-48L Power Supplies](#)).
15. Repeat steps 7 through 14 to power on the second power supply.

Onboard, Configure, and Monitor ACX7100-48L

SUMMARY

Use the information in this topic to onboard, manage, and monitor the ACX7100-48L router using Juniper Paragon Automation, or configure and monitor the router using Junos OS Evolved CLI.

IN THIS SECTION

- [Juniper Paragon Automation | 6](#)
- [Junos OS Evolved CLI | 6](#)

Juniper Paragon Automation

You can use Juniper Paragon Automation to onboard, manage, and monitor the ACX7100-48L router. See the [Juniper Paragon Automation Documentation](#) page for more information.

Junos OS Evolved CLI

You can configure and monitor the ACX7100-48L router using Junos OS Evolved CLI. For more information, see [Table 1 on page 6](#).

Table 1: Configure ACX7100-48L Using Junos OS Evolved CLI

If you want to	Then
Explore software features supported on ACX7100-48L	See Feature Explorer
Customize the basic configuration	See " Perform Initial Software Configuration for the ACX7100-48L Routers " on page 103
Learn how to configure supported software features on ACX7100-48L	See Software Documentation
Stay up-to-date about new and changed features, and known and resolved issues	See Junos OS Evolved Release Notes

2

CHAPTER

Overview

[ACX7100-48L System Overview | 8](#)

[ACX7100-48L Chassis | 15](#)

[Cooling System and Airflow in ACX7100-48L Routers | 27](#)

[ACX7100-48L Power System | 32](#)

ACX7100-48L System Overview

IN THIS SECTION

- [ACX7100-48L Router Description | 8](#)
- [ACX7100-48L Router Models | 10](#)
- [Field-Replaceable Units in ACX7100-48L Routers | 11](#)
- [Hardware Redundancy of ACX7100-48L Router Components and Functionality | 12](#)
- [ACX7100-48L Routers Hardware and CLI Terminology Mapping | 12](#)
- [ACX7100-48L System Software Overview | 14](#)

ACX7100-48L Router Description

IN THIS SECTION

- [ACX7100-48L System Overview | 9](#)
- [Benefits of ACX7100-48L Routers | 10](#)

The Juniper Networks ACX7100-48L Cloud Metro Router is a fixed-configuration, high-performance router, featuring a 1-U form factor that provides high port density, reliability, and scalability. The ACX7100-48L can be deployed as an aggregation solution in a service provider metro network or in a data center that hosts edge computing applications.

The ACX7100-48L provides several capabilities that include deep buffer and advanced timing, and a comprehensive set of features that are suited for cloud metro architectures.

You can configure and monitor ACX7100-48L routers using Junos OS Evolved CLI. You can also onboard, monitor, and manage these routers using Juniper Paragon Automation.



ACX7100-48L System Overview

The ACX7100-48L has a compact and energy-efficient design with a 4.8-Tbps-forwarding-capacity ASIC. The Routing Engine and control plane are driven by the 2.9-GHz six-core Intel CPU with 64-GB of memory and two 100-GB enterprise-grade solid-state drives (SSDs) for storage.

We ship the ACX7100-48L routers with redundant power supply modules (PSMs). You can order the routers with front-to-back airflow (airflow out or AO) or back-to-front airflow (airflow in or AI), and with AC or DC PSMs.

Figure 1 on page 9 shows the front of the ACX7100-48L router.

Figure 1: Front View of the ACX7100-48L Router

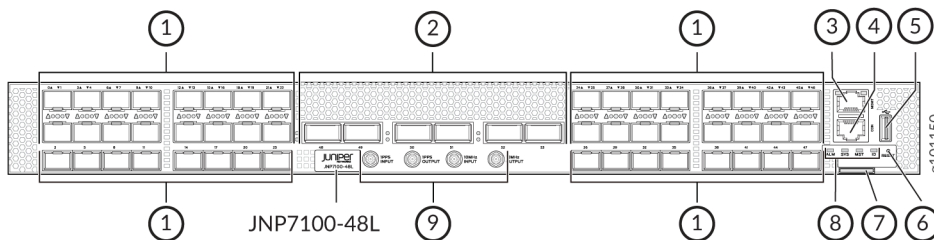

1– 50GbE/25GbE/10GbE ports (48 SFP ports). Port 47 operates only at 25-Gbps or 10-Gbps speeds.	6– RESET button
2– 400GbE/100GbE/40GbE ports (6 QSFP56-DD)	7– Pull-out tab with customer asset ID label
3– Management (MGMT) port	8– Status LEDs
4– Console (CON) port. An optional GPS time of day (TOD) device is also supported.	9– 1-PPS and 10-MHz GPS input and output ports
5– USB port	

Figure 2 on page 9 shows the rear view of an AC-powered ACX7100-48L router.

Figure 2: Rear View of an AC-Powered ACX7100-48L Router

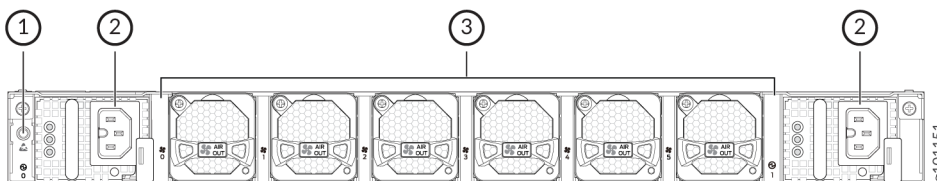

1– ESD point	3– Fan modules
2– Power supply modules (AC)	

Figure 3 on page 10 shows the rear view of a DC-powered ACX7100-48L router.

Figure 3: Rear View of a DC-Powered ACX7100-48L Router

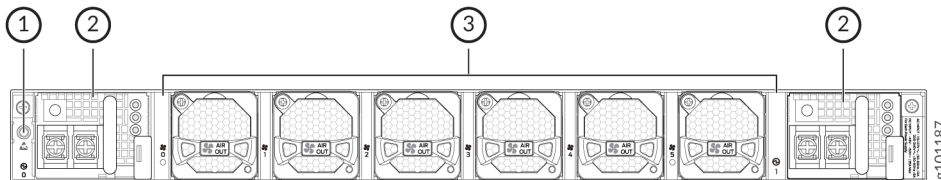

1– ESD point	3– Fan modules
2– Power supply modules (DC)	

Benefits of ACX7100-48L Routers

- **Multiservice solution**—The ACX7100-48L is a highly versatile router that provides several capabilities and use-case specific features. As an integral part of the cloud metro solution, these capabilities and features enable you to create converged, virtualized, and automated architectures to address the rapid growth of 5G, IoT, and the cloud.
- **Advanced timing features**—The ACX7100-48L supports Class C timing and major ITU-T timing profiles, making it suitable for low-latency service delivery.
- **Zero-touch provisioning**—Supports zero-touch provisioning (ZTP), which enables you to automate provisioning and deployment with minimal manual intervention. This helps save time and accelerate deployments.

ACX7100-48L Router Models

The ACX7100-48L routers are available with either AC or DC power supply modules (PSMs) and with either airflow-out (AO) or airflow-in (AI) cooling. AO is also known as front-to-back or port-to-FRU cooling. Similarly, AI is known as back-to-front or FRU-to-port cooling.

Table 2 on page 11 lists the model numbers for ACX7100-48L routers.

Table 2: ACX7100-48L Router Model Numbers and Description

Model Number	Power Supply	Airflow
ACX7100-48L-AC-AI	AC	Airflow in (back-to-front)
ACX7100-48L-DC-AI	DC	Airflow in (back-to-front)
ACX7100-48L-AC-AO	AC	Airflow out (front-to-back)
ACX7100-48L-DC-AO	DC	Airflow out (front-to-back)



CAUTION: Do not use different types of power supply modules (AC and DC) and different airflow modules (AI and AO) together in the same chassis.

Field-Replaceable Units in ACX7100-48L Routers

Field-replaceable units (FRUs) are components that you can replace at your site. The following are the ACX7100-48L FRUs:

- Power supply modules (PSMs)
- Fan modules
- Transceivers



CAUTION: Replace a failed PSM with a new PSM within three minutes of removal to maintain power redundancy. The router continues to operate with only one PSM running. Replace a failed fan module with a new fan module within one minute of removal to prevent chassis overheating.



NOTE: If you have a Juniper J-Care service contract, register any addition, change, or upgrade of hardware components at <https://www.juniper.net/customers/csc/management/updateinstallbase.jsp>. Failure to do so can result in significant delays if you

need replacement parts. This note does not apply if you replace existing components with the same type of component.



NOTE: Before removing the optical transceivers, we recommend that you disable the interface using the `set interfaces interface-name disable` command.

Hardware Redundancy of ACX7100-48L Router Components and Functionality

The following hardware components provide redundancy on ACX7100-48L routers:

- Power supply modules (PSMs)—The ACX7100-48L routers have two PSMs. Each PSM provides power to all components in the router. If two PSMs are installed, they provide full power redundancy to the device. If one PSM fails, or if you remove one PSM, the second PSM balances the electrical load without interruption.

To provide power redundancy to the system, both PSMs must be installed. Connect the first power source feed to one PSM, and connect the other power source feed to the second PSM.



CAUTION: Do not connect both the power source feeds to the same power supply input terminal.

- Cooling system—The ACX7100-48L routers have six fan modules. If a fan rotor within a fan module fails, a chassis alarm is raised. The router continues to operate with one failed rotor as per GR-63 specifications. If more than one fan rotor fails, or if a fan module is removed, a chassis alarm is raised, and the system shuts down in 240 seconds. If more than one fan module is removed, a chassis alarm is raised, and the system shuts down immediately. Therefore, if any fan module fails, you must replace the fan module immediately.

ACX7100-48L Routers Hardware and CLI Terminology Mapping

[Table 3 on page 13](#) describes the hardware terms used in ACX7100-48L router documentation and the corresponding terms used in the Junos OS CLI.

Table 3: CLI Equivalents of Terms Used in Documentation for ACX7100-48L Routers

Hardware Item (as Displayed in the CLI)	Description (as Displayed in the CLI)	Value (as Displayed in the CLI)	Item in Documentation	Additional Information
Chassis	JNP7100-48L [ACX7100-48L]	-	Router chassis	"Chassis Physical Specifications for ACX7100-48L Routers" on page 46
Routing Engine	RE-JNP-7100	-	Built-in Routing Engine	-
FPC <i>n</i>	Abbreviated name of the Flexible PIC Concentrator (an FPC is equivalent to a line card)	The value of <i>n</i> is always 0.	The router does not have actual FPCs. In this case, FPC refers to the router itself.	<i>Interface Naming Conventions Used in the Junos OS Operational Commands</i>
PIC <i>n</i>	Abbreviated name of the PIC	The value of <i>n</i> is always 0.	The router does not have physical PICs. The built-in network ports on the front panel of the router are mapped to logical PICs.	<i>Interface Naming Conventions Used in the Junos OS Operational Commands</i>
xcvr <i>n</i>	Abbreviated name of the transceiver	The value of <i>n</i> is the number of the port in which the transceiver is installed.	Optical transceivers	

Table 3: CLI Equivalents of Terms Used in Documentation for ACX7100-48L Routers (Continued)

Hardware Item (as Displayed in the CLI)	Description (as Displayed in the CLI)	Value (as Displayed in the CLI)	Item in Documentation	Additional Information
PSM (<i>n</i>)	One of the following: <ul style="list-style-type: none"> JPSU-1600W-1UACAFO JPSU-1600W-1UACAFI JPSU-1600W-1UDCAFO JPSU-1600W-1UDCAFI 	<i>n</i> is a value in the range of 0–1. The value corresponds to the power supply slot number.	AC or DC power supply module	"ACX7100-48L Power System" on page 32
Fan tray (<i>n</i>)	One of the following: <ul style="list-style-type: none"> JNP7100 Fan Tray, Front to Back Airflow - AFO JNP7100 Fan Tray, Back to Front Airflow - AFI 	<i>n</i> is a value in the range of 0–5. The value corresponds to the fan module slot number.	Fan module	"Cooling System and Airflow in ACX7100-48L Routers" on page 27

ACX7100-48L System Software Overview

The ACX7100-48L runs Junos OS Evolved, which provides Layer 2 and Layer 3 switching, routing, and security services. Junos OS Evolved runs natively on Linux, giving it direct access to all Linux utilities and operations. It is designed to be modular, allowing for upgrades to be done on a component-by-component basis without a system reboot. Only those components that are changed are restarted. Junos OS Evolved is easily portable, and minimal work is required to make it work on any platform. The Junos OS Evolved infrastructure is entirely modernized, giving you the high availability, portability, faster innovation, and simplified upgrades you need.

For information about features supported on ACX Series devices, see [Feature Explorer](#).

RELATED DOCUMENTATION

[Cooling System and Airflow in ACX7100-48L Routers | 27](#)

ACX7100-48L Chassis

IN THIS SECTION

- Management Panel of ACX7100-48L Routers | 15
- Management Port LEDs on ACX7100-48L Routers | 16
- Port Panel of ACX7100-48L Routers | 17
- Network Port LEDs on ACX7100-48L Routers | 22
- Chassis Status LEDs on ACX7100-48L Routers | 24

Management Panel of ACX7100-48L Routers

The management panel of ACX7100-48L routers is located on the front of the router along with the interface ports. [Figure 4 on page 15](#) shows the management panel components on an ACX7100-48L router.

Figure 4: Management Panel Components on ACX7100-48L Routers

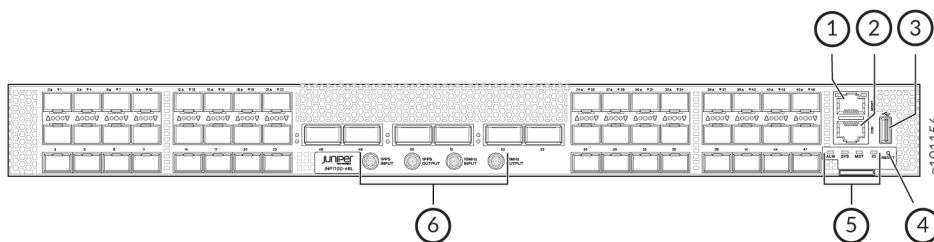

1– Management (**MGMT**) port

2– Console (**CON**) port. An optional GPS time of day (TOD) device is also supported. To connect to both a console and a TOD device simultaneously, you must use the breakout cable that is provided with the device.

4– **RESET** button

5– Status LEDs

3– USB port

6– **1-PPS** and **10-MHz** GPS input and output ports

The management panel on an ACX7100-48L router displays the router product number, and consists of the following components:

- Status LEDs—**ALM**, **SYS**, **MST**, and **ID** LEDs.
- Management (**MGMT**) port—10/100/1000BASE-T management port that uses an RJ-45 connector to connect to a management device for out-of-band management. See "[Connect an ACX7100-48L Router to a Network for Out-of-Band Management](#)" on page 101
- Console (**CON**) port—uses an RJ-45 connector to connect to a console management device. An optional GPS Time of Day (TOD) is also supported. To connect to both console and ToD simultaneously, you must use the breakout cable that is provided with the device.



NOTE: If you connect to both console and ToD simultaneously using a breakout cable, you must ensure that you have not configured the log-out-on-disconnect statement at the [edit system ports console] hierarchy level.

- USB port for image updates
- Reset button to reset the device
- SMB connector ports that support 1-PPS and 10-MHz timing devices

Management Port LEDs on ACX7100-48L Routers

The ACX7100-48L has one management port that has separate LEDs to indicate link status and link activity. The port is located on the management panel and is labeled **MGMT**. [Figure 5 on page 17](#) shows the location of the LEDs.

Figure 5: Management Port LEDs on an ACX7100-48L Router

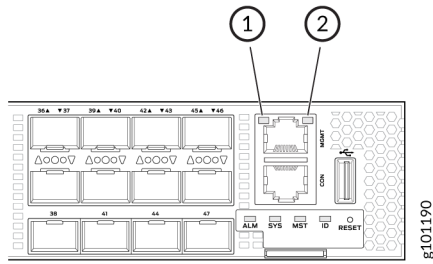

1– Link activity LED (RJ-45)

2– Status LED (RJ-45)

Table 4 on page 17 describes the RJ-45 management port LEDs on ACX7100-48L routers.

Table 4: Management Port LEDs on ACX7100-48L Routers

LED	Color	State	Description
Link activity LED	Green	Blinking	A link is established, and there is link activity.
Status LED	Unlit	Off	No link is established, or the port speed is 10Mbps.
	Yellow	On steadily	The port speed is 100 Mbps.
	Green	On steadily	The port speed is 1 Gbps.

Port Panel of ACX7100-48L Routers

IN THIS SECTION

- Guidelines for Using QDD-400G-ZR-M and JCO400-QDD-ZR-M Transceivers on ACX7100-48L AFO Models | 19

The port panel of an ACX7100-48L router has the following port configurations:

- Forty-seven small form-factor pluggable (SFP56) ports (ports **0** through **46**) that operate at 50-Gbps speed when you use SFP56 transceivers, at 25-Gbps speed when you use small form-factor pluggable (SFP28) transceivers, or at 10-Gbps speed when you use small form-factor pluggable plus (SFP+) transceivers.
- One small form-factor pluggable (SFP28) port (port **47**) that operates at 25-Gbps speed when you use SFP28 transceivers or at 10-Gbps speed when you use SFP+ transceivers.



NOTE: If PTP is configured, the port **47** is not available.

- Six double density quad small form-factor pluggable (QSFP56-DD) ports (ports **48** through **53**) that are configured as 400GbE ports by default.

The QSFP56-DD network ports support:

- QSFP56-DD transceivers
- QSFP28-DD transceivers
- QSFP28 transceivers
- QSFP+ transceivers
- Active optical cables (AOC)
- Direct attach copper (DAC) cables



NOTE: Be aware of the following ambient temperature conditions for ACX7100-48L devices:

- For ACX7100-48L AFO models, at an ambient temperature greater than 40°C (at 6000 feet altitude above sea level), you can install only 100G transceivers in any of the QSFP56-DD ports.
- For ACX7100-48L AFI models, the supported ambient temperature is 40°C (at 6000 feet altitude above sea level).



NOTE: The QDD-400G-ZR and QDD-400G-ZR-M transceivers are supported only in the ACX7100-48L AFO models. To support the QDD-400G-ZR-M transceivers, you must update the temperature thresholds of the inlet sensors. However, for the QDD-400G-ZR transceivers, you need not update the default temperature threshold values. For more

information about supporting the QDD-400G-ZR-M transceivers on ACX7100-48L AFO models, see "[Guidelines for Using QDD-400G-ZR-M and JCO400-QDD-ZR-M Transceivers on ACX7100-48L AFO Models](#)" on page 19.

Figure 6 on page 19 shows the port panel on an ACX7100-48L router.

Figure 6: ACX7100-48L Router Port Panel

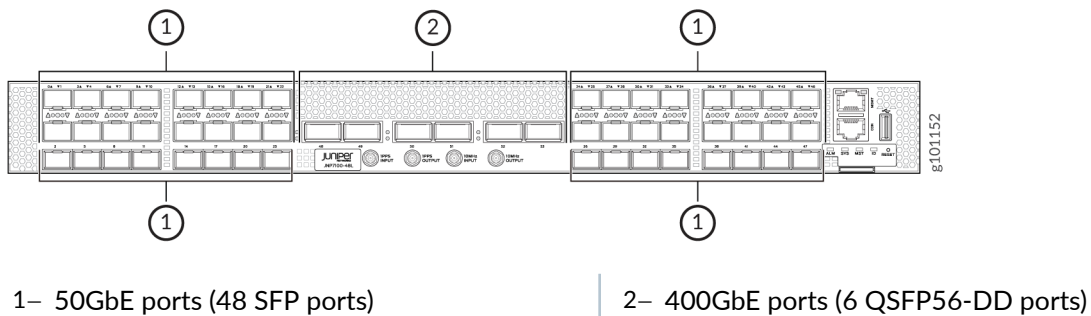

NOTE: To understand all the potential restrictions and validate different port configurations on an ACX7100-48L router, use the [Port Checker Tool](#).

Guidelines for Using QDD-400G-ZR-M and JCO400-QDD-ZR-M Transceivers on ACX7100-48L AFO Models

Before you install the QDD-400G-ZR-M and JCO400-QDD-ZR-M transceivers, you must update the temperature thresholds of the inlet sensors to facilitate an increase in fan speeds. This prevents the transceivers from powering off. We recommend that you update the temperature thresholds at ambient room temperature (23°C to 27°C).

Update the Temperature Thresholds

The following example requires you to navigate various levels in the configuration hierarchy. For information about navigating the CLI, see the [CLI User Guide](#).

To update the temperature thresholds, in configuration mode, perform the following steps on an ACX7100-48L device:

1. Update the temperature thresholds for the Main PCBLeft temperature sensor by executing the following commands:

for QDD-400G-ZR-M:

```
[edit]
user@host#set chassis cb 0 temperature-sensor "Main PCBLeft" temperature-threshold fans-on-
full-speed 48
user@host#set chassis cb 0 temperature-sensor "Main PCBLeft" temperature-threshold fans-on-
full-speed-if-failed-fan 48
user@host#set chassis cb 0 temperature-sensor "Main PCBLeft" temperature-threshold fans-on-
intermediate-speed 36
user@host#set chassis cb 0 temperature-sensor "Main PCBLeft" temperature-threshold fans-to-
normal-speed 30
```

for JCO400-QDD-ZR and JCO400-QDD-ZR-M:

```
[edit]
user@host#set chassis cb 0 temperature-sensor "Main PCBLeft" temperature-threshold fans-on-
full-speed 38
user@host#set chassis cb 0 temperature-sensor "Main PCBLeft" temperature-threshold fans-on-
full-speed-if-failed-fan 38
user@host#set chassis cb 0 temperature-sensor "Main PCBLeft" temperature-threshold fans-on-
intermediate-speed 26
user@host#set chassis cb 0 temperature-sensor "Main PCBLeft" temperature-threshold fans-to-
normal-speed 21
```

2. Update the temperature thresholds for the Main PCBRight temperature sensor by executing the following commands:

for QDD-400G-ZR-M:

```
[edit]
user@host#set chassis cb 0 temperature-sensor "Main PCBRight" temperature-threshold fans-on-
full-speed 48
user@host#set chassis cb 0 temperature-sensor "Main PCBRight" temperature-threshold fans-on-
full-speed-if-failed-fan 48
user@host#set chassis cb 0 temperature-sensor "Main PCBRight" temperature-threshold fans-on-
intermediate-speed 36
```

```
user@host#set chassis cb 0 temperature-sensor "Main PCBRight" temperature-threshold fans-to-normal-speed 30
```

for JCO400-QDD-ZR-M:

```
[edit]
user@host#set chassis cb 0 temperature-sensor "Main PCBRight" temperature-threshold fans-on-full-speed 38
user@host#set chassis cb 0 temperature-sensor "Main PCBRight" temperature-threshold fans-on-full-speed-if-failed-fan 38
user@host#set chassis cb 0 temperature-sensor "Main PCBRight" temperature-threshold fans-on-intermediate-speed 26
user@host#set chassis cb 0 temperature-sensor "Main PCBRight" temperature-threshold fans-to-normal-speed 21
```

3. Commit the configuration.

```
[edit]
user@host#commit
```

In the above example, the threshold values are updated to support the JCO400-QDD-ZR-M and QDD-400G-ZR-M transceivers. If you are not using the JCO400-QDD-ZR-M and QDD-400G-ZR-M transceivers, you will need to delete the changes made to the temperature thresholds. To do this, in configuration mode, perform the following steps:

1. Delete the Main PCBLeft and Main PCBRight temperature sensors.

```
[edit]
user@host#delete chassis cb 0 temperature-sensor "Main PCBLeft"
user@host#delete chassis cb 0 temperature-sensor "Main PCBRight"
```

2. Commit the configuration.

```
[edit]
user@host#commit
```

Verify the Updated Temperature Thresholds

You can verify the changes made to temperature thresholds by using any of the following methods:

- In operational mode, run the `show chassis enhanced-temperature-thresholds` command to view the configured thresholds for all the sensors.
- In configuration mode, execute the following command:

```
user@host# show chassis cb 0
temperature-sensor "Main PCBLeft" {
  temperature-threshold {
    fans-to-normal-speed 30;
    fans-on-intermediate-speed 36;
    fans-on-full-speed 48;
    fans-on-full-speed-if-failed-fan 48;
  }
}
temperature-sensor "Main PCBRight" {
  temperature-threshold {
    fans-to-normal-speed 30;
    fans-on-intermediate-speed 36;
    fans-on-full-speed 48;
    fans-on-full-speed-if-failed-fan 48;
  }
}
```

Network Port LEDs on ACX7100-48L Routers

Each ACX7100-48L network port uses a single bicolored LED to indicate link status, activity on the link, or a fault condition. [Figure 7 on page 23](#) and [Figure 8 on page 23](#) show the location of the LEDs on an ACX7100-48L device.

Figure 7: QSFP56-DD Port LEDs

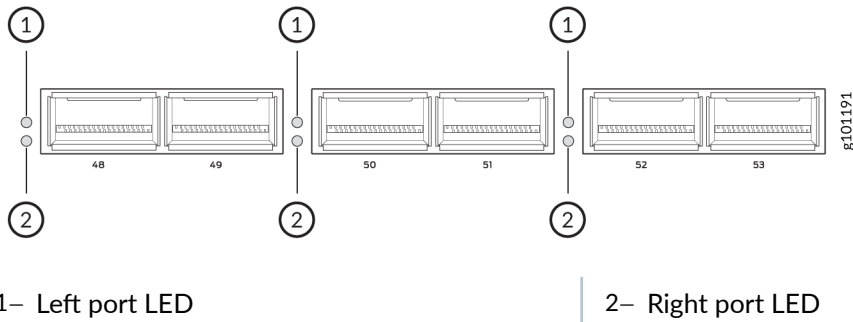

1- Left port LED

2- Right port LED

Figure 8: SFP56 Port LEDs

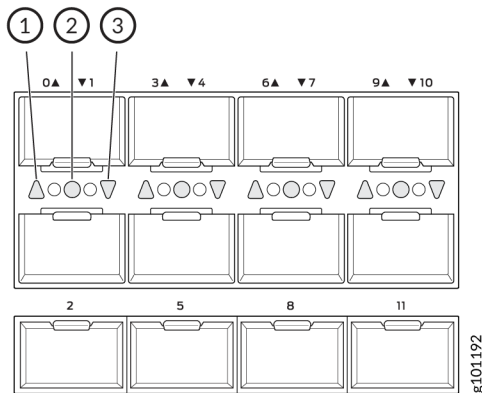

1- Upper port LED

3- Lower port LED

2- Middle port LED

The number next to the LED indicates the port number to which the LED belongs. All network port LEDs behave the same. [Table 5 on page 23](#) describes the network port LEDs on ACX7100-48L routers, their colors and states, and the status that they indicate.

Table 5: Network Port LEDs on ACX7100-48L Routers

LED Color	LED State	Description
Unlit	Off	The port is administratively disabled, there is no power, the link is down, or a transceiver is not present.

Table 5: Network Port LEDs on ACX7100-48L Routers (*Continued*)

LED Color	LED State	Description
Green	On steadily	A link is established, and all channels are up.
	Blinking	The beacon function is enabled on the port.
Amber	On steadily	One or more channels are up. At least one channel has activity, but not all connections are active.
Red	On steadily	All channels are down.

Chassis Status LEDs on ACX7100-48L Routers

The ACX7100-48L routers have four status LEDs that indicate the system status. You can find these LEDs to the right of the network ports (see [Figure 9 on page 24](#)).

Figure 9: Chassis Status LEDs on an ACX7100-48L Router

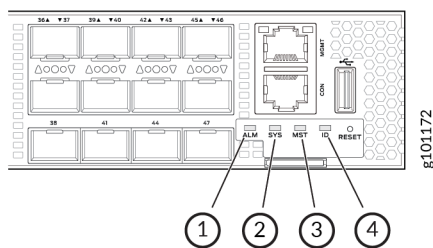
1– **ALM** (Alarm)3– **MST** (Primary)2– **SYS** (System)4– **ID** (Identification)

[Table 6 on page 25](#) describes the chassis status LEDs on ACX7100-48L routers, their colors and states, and the status that they indicate. You can view the colors of the LEDs remotely through the CLI by running the operational mode command `show chassis led`.

Table 6: Chassis Status LEDs on ACX7100-48L Routers

Name	Color	State	Description
ALM—Alarm LED	Unlit	Off	The router is halted, or there is no alarm.
	Red	On steadily	A major hardware fault has occurred, such as a temperature alarm or power failure, and the router has halted (except during a single rotor failure in a fan module). Switch off power to the router and unplug the power cords. Correct any voltage or site temperature issues, and allow the router to cool down. Power on the router, and monitor the power supply and fan LEDs to determine where the error is occurring.
		Blinking	Indicates the presence of a major and a minor alarm.
	Amber	On steadily	A minor alarm has occurred, such as a software error. Switch off power to the router and unplug the power cords. Power on the router, and monitor the status LEDs to ensure that Junos OS Evolved boots up properly.
		Blinking	Indicates the presence of a major and a minor alarm.
SYS—System LED	Unlit	Off	The router is powered off or halted.
	Green	On steadily	Junos OS Evolved is loaded on the router.

Table 6: Chassis Status LEDs on ACX7100-48L Routers (*Continued*)

Name	Color	State	Description
		Blinking	The device is loading the Software or the device is powering off.
		Slow blinking	The device is powering up.
MST —Primary LED	Unlit	Off	The router is a linecard member.
	Green	On steadily	The router is a standalone router.
ID —Identification LED	Unlit	Off	The beacon feature is not enabled on the router. You can enable this feature by using the request chassis beacon command.
	Blue	Blinking	The beacon feature is enabled on the router. You can disable this feature by using the request chassis beacon command.

RELATED DOCUMENTATION

| [ACX7100-48L System Overview](#) | 8

Cooling System and Airflow in ACX7100-48L Routers

IN THIS SECTION

- Fan Modules | 27
- Fan Module and Power Supply Requirements | 30
- Fan Status LEDs on ACX7100-48L Routers | 31

The cooling system in ACX7100-48L routers consists of six fan modules and a single fan in each power supply module (PSM). The ACX7100-48L routers can be set up with the following airflow directions:

- Air in (AI)—Air comes into the router through the vents in the field-replaceable units (FRUs).
- Air out (AO)—Air comes into the router through the vents in the front panel.



CAUTION: Do not use fan modules and PSMs with **AIR OUT** and **AIR IN** labels together in the same chassis.

Fan Modules

The fan modules in ACX7100-48L routers are hot-insertable and hot-removable field-replaceable units (FRUs). The fan modules are installed in the fan module slots on the rear of the router. The ACX7100-48L routers support six fan modules numbered **0** through **5** from left to right. Each fan module slot has a fan icon next to it.

The ACX7100-48L routers are available with either front-to-back airflow (airflow out, ports-to-FRUs, or AO) or back-to-front airflow (airflow in, FRUs-to-ports, or AI). In AO models, the air is pulled in through the front of the chassis toward the fan modules, from where it is exhausted out of the chassis. In AI models, the air is pulled in through the fan modules and toward the front of the chassis, from where it is exhausted out of the chassis. The fan modules and the power supply modules are available in both AO and AI models.

[Figure 10 on page 28](#) shows an ACX7100-48L AO fan module.

Figure 10: AO Fan Module Used in ACX7100-48L Routers

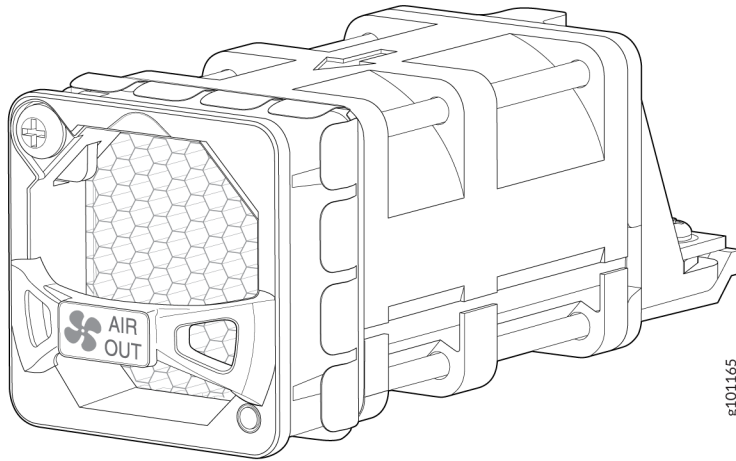

You remove and replace a fan module from the FRU end of the chassis. The router continues to operate for a limited period of time (240 seconds) during the replacement of the fan module without thermal shutdown.



NOTE: All fan modules must be installed for optimal operation of the router.

Table 7 on page 28 lists the available fan modules and the direction of airflow in them.

Table 7: Fan Module in ACX7100-48L Routers

Fan Module	Airflow Diagram	Label on the Fan Module Handle	Direction of Airflow in the Fan Module	Power Supplies
JNP7100-FAN1RU-AI	Figure 11 on page 29	AIR IN	Air is pulled in through the fan modules and toward the front of the chassis, from where it is exhausted out of the chassis.	You must install PSMs that have AIR IN labels only in those routers in which the fan modules have AIR IN labels.

Table 7: Fan Module in ACX7100-48L Routers (Continued)

Fan Module	Airflow Diagram	Label on the Fan Module Handle	Direction of Airflow in the Fan Module	Power Supplies
JNP7100-FAN1RU-AO	Figure 12 on page 30	AIR OUT	Air is pulled in through the front of the chassis toward the fan modules, from where it is exhausted out of the chassis.	You must install PSMs that have AIR OUT labels only in those routers in which the fan modules have AIR OUT labels.

In data center deployments, position the router in such a manner that the **AIR IN** labels on the router components are facing the cold aisle, and the **AIR OUT** labels on the router components are facing the hot aisle.

Figure 11: Air-In (AI) Airflow Through ACX7100-48L Chassis

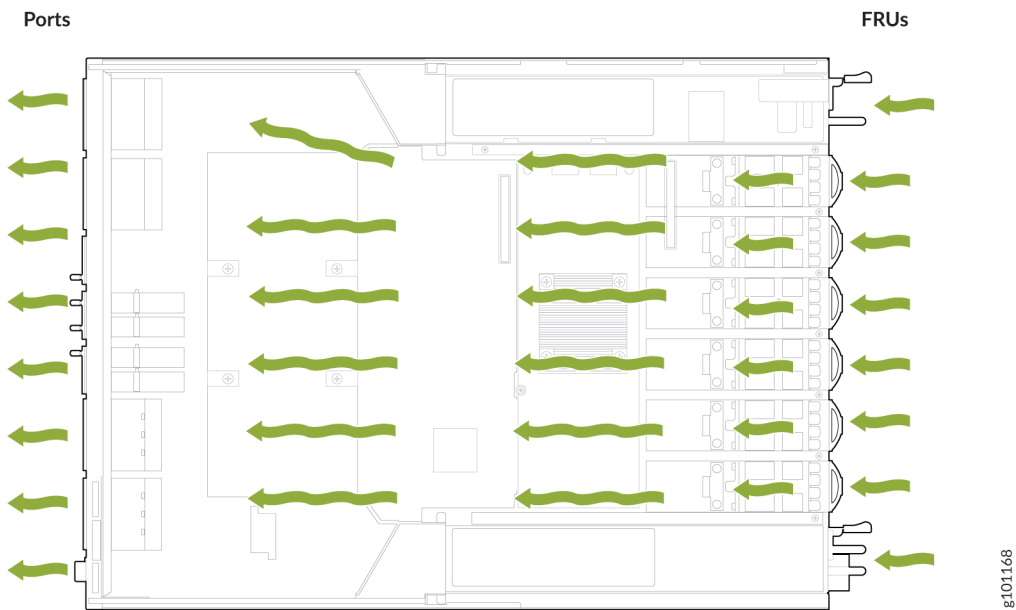
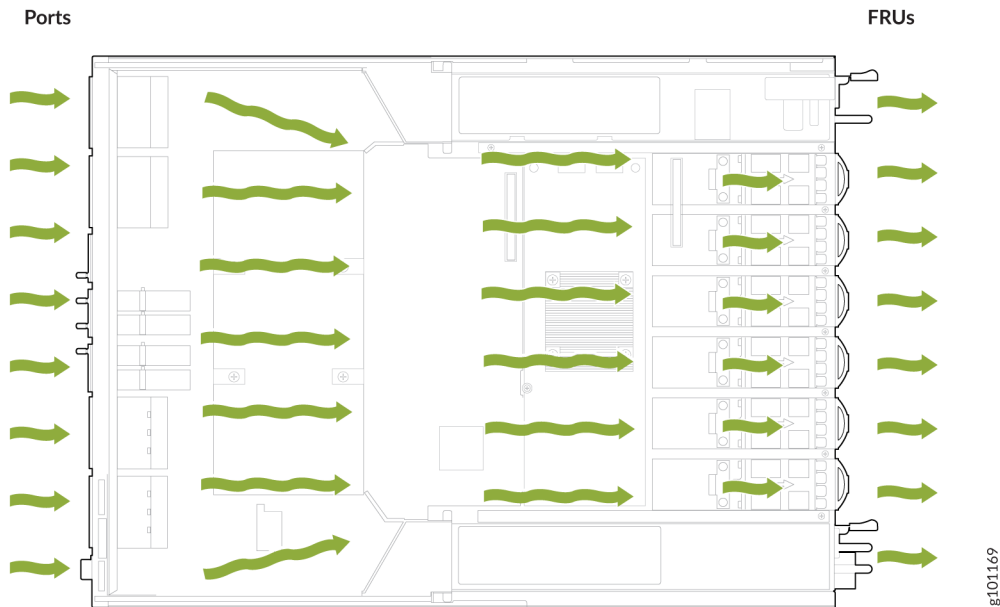

Figure 12: Air-Out (AO) Airflow Through ACX7100-48L Chassis



Fan Module and Power Supply Requirements

Do not mix PSMs with different airflows. Ensure that the chassis is using either all airflow-in (**AIR IN**) models or all airflow-out (**AIR OUT**) models.

Similarly, ensure that all fan modules have the same airflow that matches the airflow of the PSMs. Mixing components with different airflows in the same chassis hampers the performance of the cooling system of the router and leads to overheating of the chassis. An alarm is raised if you install fan modules with different airflows in the chassis.



CAUTION: The system raises an alarm if a fan module fails, or if the ambient temperature inside the chassis rises above the acceptable range. If the temperature inside the chassis rises above the threshold temperature, the system shuts down automatically.

Do not mix fan modules. Use only the replacement fan modules that are designed for use with your product. See [Table 7 on page 28](#) for the correct part number for your ACX7100-48L router.

If you need to change the airflow direction in an ACX7100 router, you can change the airflow pattern. To convert an **AIR IN** product model to an **AIR OUT** product model, or an **AIR OUT** product model to an

AIR IN product model, you must replace all of the fan modules and PSMs at one time to use the new airflow direction.

NOTE: You must power off the device before replacing all the fans and power supply modules, and then power on the device. If you replace the fans or PSMs without powering off the device, the system raises an alarm.

Fan Status LEDs on ACX7100-48L Routers

You can check the status of the fan modules by using the `show system alarms` command, or by examining the LEDs next to each fan module.

On the ACX7100-48L routers, the fan module LEDs are located on the chassis next to the fan module slot. [Figure 13 on page 31](#) shows the location of the fan module LEDs on an ACX7100-48L router.

Figure 13: Fan Status LEDs on ACX7100-48L Routers

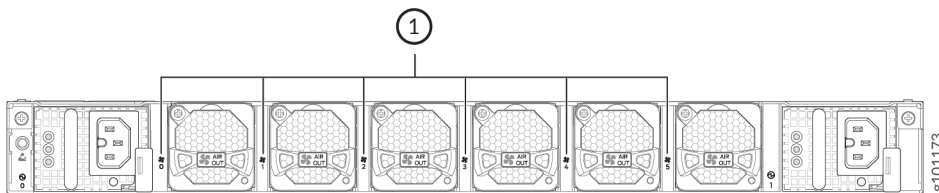

1– Fan status LEDs

[Table 8 on page 31](#) describes the function of the fan status LED.

Table 8: Fan Status LED on ACX7100-48L Routers

Name	Color	State	Description
Fan status LED	Green	On steadily	The fan module is operating normally. The system has verified that the module is engaged, that the airflow is in the correct direction, and that the fan is operating correctly.

Table 8: Fan Status LED on ACX7100-48L Routers (Continued)

Name	Color	State	Description
	Red	On steadily	An error has been detected in the fan module. Replace the fan module as soon as possible. Either the fan has failed, or it is seated incorrectly. To maintain proper airflow through the chassis, leave the fan module installed in the chassis until you are ready to replace it.

Under normal operating conditions, the fan modules operate at a moderate speed. Temperature sensors in the chassis monitor the temperature within the chassis.

The system raises an alarm if a fan module fails or if the ambient temperature inside the chassis rises above the acceptable range. If the ambient temperature rises, the fan speed increases to lower the ambient temperature. However, if the temperature inside the chassis rises above the threshold temperature, the system shuts down automatically.

RELATED DOCUMENTATION

[ACX7100-48L System Overview | 8](#)

[ACX7100-48L Power System | 32](#)

ACX7100-48L Power System

IN THIS SECTION

- [AC Power Supply for ACX7100-48L Routers | 33](#)
- [AC Power Specifications for ACX7100-48L Routers | 34](#)
- [AC Power Cord Specifications for ACX7100-48L Routers | 35](#)
- [AC Power Supply Module LEDs on ACX7100-48L Routers | 37](#)
- [DC Power Supply for ACX7100-48L Routers | 38](#)
- [DC Power Specifications for ACX7100-48L Routers | 39](#)

AC Power Supply for ACX7100-48L Routers

The ACX7100-48L AC router operates at a maximum of 1600 W. The two power supply modules (PSMs) in ACX7100-48L routers are hot-removable and hot-insertable field-replaceable units (FRUs). The PSMs are preinstalled in the router. You can replace the PSMs without powering off the router or disrupting the router function.



NOTE: Both the AI and AO PSMs look similar. Be sure to use the correct PSM for your chassis product model.



CAUTION: Do not mix PSMs with different airflow directions in the same chassis. The system raises an alarm when a PSM that has a different airflow direction is inserted into the chassis.



CAUTION: Do not use AC and DC PSMs together in the same chassis.

Figure 14 on page 33 shows the AC PSM in ACX7100-48L routers.

Figure 14: AC PSM in an ACX7100-48L Router

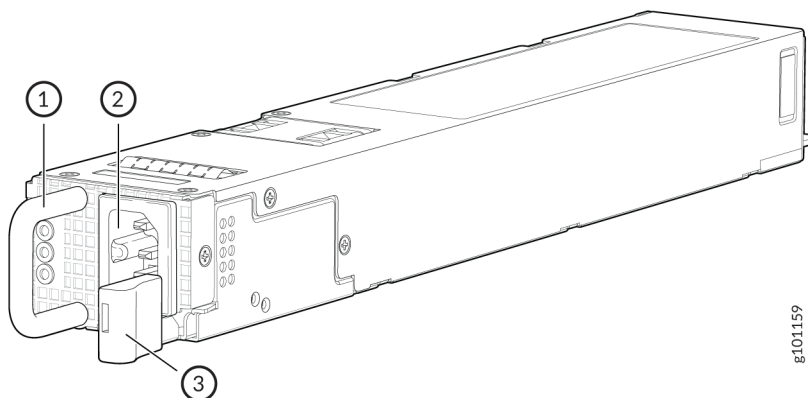

1– Handle

3– Latch lever

g101159

2– AC inlet

The PSMs provide FRU-to-port or port-to-FRU airflow, depending on the product model that you purchase.



CAUTION: Verify that the airflow direction on the PSM handle matches the direction of airflow in the chassis. Ensure that each PSM that you install in the chassis has the same airflow direction. If you install PSMs with different airflow directions, Junos raises an alarm. If you need to convert the airflow pattern on a chassis, you must replace all the fans and PSMs at one time to use the new direction.

Table 9 on page 34 shows the different AC PSMs and their airflow direction for ACX7100-48L routers.

Table 9: Airflow Direction in AC PSMs for ACX7100-48L

Power Supply Modules	Wattage	Direction of Airflow
JPSU-1600W-1UACAFI	1600 W	Airflow in (back-to-front)
JPSU-1600W-1UACAFO		Airflow out (front-to-back)

AC Power Specifications for ACX7100-48L Routers

Table 10 on page 34 describes the AC power supply module (PSM) ratings and Table 11 on page 35 describes the power consumption for ACX7100-48L routers.

Table 10: AC PSM Ratings for ACX7100-48L Routers

Item	Specifications for ACX7100-48L
AC input voltage	Operating range: 100 / 240 VAC
AC input line frequency	50–60 Hz

Table 10: AC PSM Ratings for ACX7100-48L Routers (Continued)

Item	Specifications for ACX7100-48L
AC input current rating	13.6 A at 100-127 VAC 12.7 A at 115-127 VAC 9.4 A at 200-240 VAC

Table 11: Power Consumption for ACX7100-48L Routers

Item	Specifications
Typical power consumption (at 25°C ambient temperature and without optics)	570 W
Maximum power consumption (at 40°C ambient temperature and without optics)	960 W

AC Power Cord Specifications for ACX7100-48L Routers

We ship detachable AC power cords with the chassis if you include them as part of your order. The coupler is type C15 as described by International Electrotechnical Commission (IEC) standard 60320. The plug end of the power cord fits into the power source outlet that is standard for your geographical location.





NOTE: In North America, AC power cords must not exceed 4.5 meters in length to comply with National Electrical Code (NEC) Sections 400-8 (NFPA 75, 5-2.2) and 210-52 and Canadian Electrical Code (CEC) Section 4-010(3). The ACX Series power cords comply with the standards.

Table 12 on page 36 lists the AC power cord specifications for each country or region.

Table 12: AC Power Cord Specifications

Country/Region	Electrical Specifications	Plug Standards	Juniper Model Number	Spare Juniper Model Number	Graphic
Argentina	250 VAC, 10 A, 50 Hz	IRAM 2073 Type RA/3	-	CBL-PWR-C15M-HITEMP-AR	
Australia	250 VAC, 10 A, 50 Hz	AS/NZS 3112-2000 Type SAA/3	CG_CBL-C15-02-AU	CBL-PWR-C15M-HITEMP-AU	
Brazil	250 VAC, 10 A, 50 Hz	NBR 14136 Type BR/3	-	CBL-PWR-C15M-HITEMP-BR	
China	250 VAC, 10 A, 50 Hz	GB 2099/GB 1002 Type PRC/3	CG_CBL-C15-02-CH	CBL-PWR-C15M-HITEMP-CH	
Europe (except Italy, Switzerland, and United Kingdom)	250 VAC, 10 A, 50 Hz	CEE (7) VII Type VIIG	CG_CBL-C15-02-EU	CBL-PWR-C15M-HITEMP-EU	
Italy	250 VAC, 10 A, 50 Hz	CEI 23-16 Type I/3G	CG_CBL-C15-02-IT-CH	CBL-PWR-C15M-HITEMP-IT	
Japan	125 VAC, 15 A, 50 Hz	JIS 8303 Type 498GJ	CG_CBL-C15-02-JP	CBL-PWR-C15M-HITEMP-JP	
North America	125 VAC, 15 A, 50 Hz	NEMA 5-15 Type 498G	CG_CBL-C15-02-US	CBL-PWR-C15M-HITEMP-US	

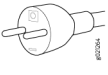
Table 12: AC Power Cord Specifications (Continued)

Country/Region	Electrical Specifications	Plug Standards	Juniper Model Number	Spare Juniper Model Number	Graphic
South Africa and India	250 VAC, 10 A, 50 Hz	SABS 164/1:1992 Type ZA/3	-	CBL-PWR-C15M-HITEMP-SA	
South Korea and some parts of Europe	250 VAC, 10 A, 50 Hz	CEE(7) VII Type VIIG	-	CBL-PWR-C15M-HITEMP-KR	
Switzerland	250 VAC, 10 A, 50 Hz	SEV 1011/6534-2 Type 12G	CG_CBL-C15-02-SZ	CBL-PWR-C15M-HITEMP-SZ	
United Kingdom	250 VAC, 10 A, 50 Hz	BS 1363/A Type BS89/13	CG_CBL-C15-02-UK	CBL-PWR-C15M-HITEMP-UK	

AC Power Supply Module LEDs on ACX7100-48L Routers

The AC power supply module (PSM) on an ACX7100-48L router uses three LEDs to indicate power status. [Figure 15 on page 37](#) shows the location of the LEDs on the AC PSM.

Figure 15: AC PSM LEDs on an ACX7100-48L Router

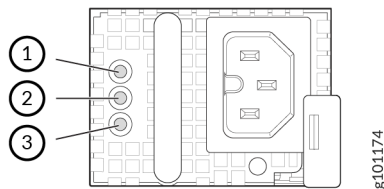

1- AC Input status LED	3- Fault LED
2- DC Output status LED	

Table 13 on page 38 describes the LEDs on the AC PSM.

Table 13: AC PSM LEDs

LED	Color	State	Description
AC input status LED	Unlit	Off	The PSM is disconnected from power, or there is no input power to the PSM.
	Green	On steadily	There is input AC power supply to the PSM.
DC output status LED	Unlit	Off	There is no output voltage from the PSM. Check the PSM.
	Green	On steadily	There is output voltage from the PSM.
Fault LED	Amber	On steadily	An error is detected in the PSM. Replace the PSM as soon as possible. To maintain proper airflow through the chassis, leave the PSM installed in the chassis until you are ready to replace it.
		Blinking	The PSM is an invalid model.

DC Power Supply for ACX7100-48L Routers

The two power supply modules (PSMs) in ACX7100-48L routers are hot-removable and hot-insertable field-replaceable units (FRUs). The PSMs are preinstalled in the router. The DC power supply in ACX7100-48L is 1600 W with dual feeds for power resiliency. You can install replacement PSMs without powering off the router or disrupting the router function.



NOTE: Both the AI and AO PSMs look similar. Be sure to use the correct PSM for your chassis product model.



CAUTION: Do not mix PSMs with different airflow directions. The system raises an alarm when a PSM that has a different airflow direction is inserted into the chassis.

Figure 16 on page 39 shows the DC PSM in ACX7100-48L routers.

Figure 16: DC PSM in an ACX7100-48L Router

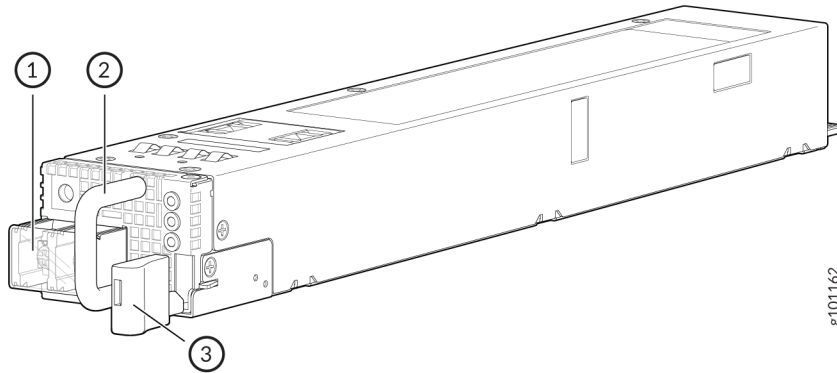

1– Terminal block cover

3– Latch lever

2– Handle

Table 14 on page 39 shows the different PSMs and their airflow direction for ACX7100-48L routers.

Table 14: Airflow Direction in DC PSMs for ACX7100-48L

Power Supply Module Number	Wattage	Direction of Airflow
JPSU-1600W-1UDCAFI	1600 W	Airflow in (back-to-front)
JPSU-1600W-1UDCAFO		Airflow out (front-to-back)

DC Power Specifications for ACX7100-48L Routers

Table 15 on page 40 describes the DC power supply module (PSM) ratings and Table 16 on page 40 describes the power consumption for ACX7100-48L routers.

Table 15: DC PSM Ratings for ACX7100-48L Routers

Item	Specifications for ACX7100-48L
DC input voltage	<ul style="list-style-type: none"> Rated operating voltage: VDC -48 VDC through -60 VDC Operating voltage range: -40 VDC through -72 VDC
DC input line current	27.5 A maximum

Table 16: Power Consumption for ACX7100-48L Routers

Item	Specifications
Typical power consumption (at 25°C ambient temperature and without optics)	570 W
Maximum power consumption (at 40°C ambient temperature and without optics)	960 W

DC Power Supply Module LEDs on ACX7100-48L Routers

Figure 17 on page 40 shows the location of the LEDs on the DC power supply module (PSM).

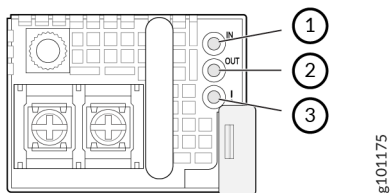
Figure 17: DC PSM LEDs

1– Input LED (IN)

2– Output LED (OUT)

3– Fault LED (!)

Table 17 on page 41 describes the LEDs on the DC PSMs.

Table 17: DC PSM LEDs on ACX7100-48L Routers

Name	Color	State	Description
IN (input)	Unlit	Off	There is no input power to the PSM.
	Green	On steadily	There is input DC power to the PSM.
OUT (output)	Unlit	Off	There is no output voltage from the PSM. Check the PSM.
	Green	On steadily	There is output voltage from the PSM.
! (fault)	Amber	On steadily	An error is detected in the PSM. Replace the PSM as soon as possible. To maintain proper airflow through the chassis, leave the PSM installed in the chassis until you are ready to replace it.

RELATED DOCUMENTATION

[ACX7100-48L System Overview | 8](#)

[Maintaining the ACX7100-48L Power Supplies | 111](#)

3

CHAPTER

Site Planning, Preparation, and Specifications

Site Preparation Checklist for ACX7100-48L Routers | 43

ACX7100-48L Site Guidelines and Requirements | 44

ACX7100-48L Network Cable and Transceiver Planning | 54

ACX7100-48L Management and Console Port Specifications and Pinouts | 66

Site Preparation Checklist for ACX7100-48L Routers

The checklist in [Table 18 on page 43](#) summarizes the tasks you need to perform when preparing a site for an ACX7100-48L router installation.

Table 18: Site Preparation Checklist

Item or Task	For More Information	Performed by	Date
Environment			
Verify that environmental factors such as temperature and humidity do not exceed router tolerances.	"Environmental Requirements and Specifications for ACX7100-48L Routers" on page 47		
Power			
Measure the distance between external power sources and router installation site.			
Calculate the power consumption and requirements.	"AC Power Specifications for ACX7100-48L Routers" on page 34 "DC Power Specifications for ACX7100-48L Routers" on page 39		
Rack or Cabinet			
Verify that your rack or cabinet meets the minimum requirements for the installation of the router.	"Rack Requirements for ACX7100-48L Routers" on page 50		
Plan rack or cabinet location, including required space clearances.	"Clearance Requirements for Hardware Maintenance of ACX7100-48L Routers" on page 49		

Table 18: Site Preparation Checklist (Continued)

Item or Task	For More Information	Performed by	Date
Secure the rack or cabinet to the floor and building structure.			
Cables			
Acquire cables and connectors: <ul style="list-style-type: none"> • Determine the number of cables needed based on your planned configuration. • Review the maximum distance allowed for each cable. Choose the length of cable based on the distance between the hardware components being connected. 	"Determining Transceiver Support for ACX7100-48L" on page 54 "Cable and Connector Specifications for ACX7100-48L" on page 55		
Plan the cable routing and management.			

ACX7100-48L Site Guidelines and Requirements

IN THIS SECTION

- [General Site Guidelines | 45](#)
- [Site Electrical Wiring Guidelines | 45](#)
- [Chassis Physical Specifications for ACX7100-48L Routers | 46](#)
- [Environmental Requirements and Specifications for ACX7100-48L Routers | 47](#)
- [Grounding Cable and Lug Specifications for ACX7100-48L | 48](#)
- [Clearance Requirements for Hardware Maintenance of ACX7100-48L Routers | 49](#)
- [Rack Requirements for ACX7100-48L Routers | 50](#)

General Site Guidelines

Efficient device operation requires proper site planning and maintenance and proper layout of the equipment, rack or cabinet (if used), and wiring closet.

To plan and create an acceptable operating environment for your device and prevent environmentally caused equipment failures:

- Keep the area around the chassis free from dust and conductive material, such as metal flakes.
- Follow prescribed airflow guidelines to ensure that the cooling system functions properly and that exhaust from other equipment does not blow into the intake vents of the device.
- Follow the prescribed electrostatic discharge (ESD) prevention procedures to prevent damaging the equipment. Static discharge can cause components to fail completely or intermittently over time.
- Install the device in a secure area, so that only authorized personnel can access the device.

Site Electrical Wiring Guidelines

[Table 19 on page 46](#) describes the factors you must consider while planning the electrical wiring at your site.



WARNING: You must provide a properly grounded and shielded environment and use electrical surge-suppression devices.

Avertissement Vous devez établir un environnement protégé et convenablement mis à la terre et utiliser des dispositifs de parasurtension.

Table 19: Site Electrical Wiring Guidelines

Site Wiring Factor	Guidelines
Signaling limitations	<p>If your site experiences any of the following problems, consult experts in electrical surge suppression and shielding:</p> <ul style="list-style-type: none"> • Improperly installed wires cause radio frequency interference (RFI). • Damage from lightning strikes occurs when wires exceed recommended distances or pass between buildings. • Electromagnetic pulses (EMPs) caused by lightning damage unshielded conductors and electronic devices.
Radio frequency interference	<p>To reduce or eliminate RFI from your site wiring, do the following:</p> <ul style="list-style-type: none"> • Use a twisted-pair cable with a good distribution of grounding conductors. • If you must exceed the recommended distances, use a high-quality twisted-pair cable with one ground conductor for each data signal when applicable.
Electromagnetic compatibility	<p>If your site is susceptible to problems with electromagnetic compatibility (EMC), particularly from lightning or radio transmitters, seek expert advice.</p> <p>Some of the problems caused by strong sources of electromagnetic interference (EMI) are:</p> <ul style="list-style-type: none"> • Destruction of the signal drivers and receivers in the device • Electrical hazards as a result of power surges conducted over the lines into the equipment

Chassis Physical Specifications for ACX7100-48L Routers

The ACX7100-48L router chassis is a rigid sheet-metal structure that houses the hardware components. [Table 20 on page 47](#) summarizes the physical specifications of an ACX7100-48L router and its components.

Table 20: Physical Specifications for ACX7100-48L Router Chassis and FRUs

Item	Height	Width	Depth	Weight
ACX7100-48L	1.75 in. (4.45 cm)	17.36 in. (44.09 cm)	Without fan module and power supply module (PSM) handles: 23.42 in. (59.5 cm) With fan module and PSM handles: 24.94 in. (63.88 cm)	<ul style="list-style-type: none"> With FRUs installed: 26.94 lb (12.22 kg) With no FRUs installed: 20.54 lb (9.32 kg)
Fan module	1.61 in. (4.10 cm)	1.64 in. (4.18 cm)	4.07 in. (10.34 cm)	0.28 lb (0.13 kg)
AC PSM	1.58 in. (4.01 cm)	2.14 in. (5.43 cm)	12.65 in. (32.13 cm)	2.33 lb (1.05 kg)
DC PSM	1.57 in. (4 cm)	2.14 in. (5.43 cm)	12.65 in. (32.13 cm)	2.40 lb (1.09 kg)

Environmental Requirements and Specifications for ACX7100-48L Routers

The router must be installed in a rack or cabinet. The router must be housed in a dry, clean, well-ventilated, and temperature-controlled environment.

Follow these environmental guidelines:

- The site must be as dust-free as possible because dust can clog air intake vents and filters, reducing the efficiency of the router cooling system.
- Maintain ambient airflow for normal router operation. If the airflow is blocked or restricted, or if the intake air is too warm, the router might overheat and the router temperature monitor might shut down the device to protect the hardware components.

[Table 21 on page 48](#) provides the required environmental conditions for normal router operation.

Table 21: ACX7100-48L Router Environmental Tolerances

Description	Tolerance
Altitude	No performance degradation up to 6,000 feet (1,829 meters)
Relative humidity	<p>Normal operation ensured in relative humidity range of 5% through 90%, noncondensing.</p> <ul style="list-style-type: none"> Short-term operation ensured in relative humidity range of 5% through 93%, noncondensing. <p>NOTE: As defined in NEBS GR-63-CORE, short-term events can be up to 96 hours in duration but not more than 15 days per year.</p>
Temperature	<ul style="list-style-type: none"> Normal operation ensured in temperature range of 32° F through 104° F (0° C through 40° C). Non-operating storage temperature in shipping container: -40° F through 158° F (-40° C through 70° C).
Seismic	Complies with Zone 4 earthquake requirements according to NEBS GR-63-CORE.



NOTE: Install ACX Series devices only in restricted-access areas, such as dedicated equipment rooms and equipment closets, in accordance with Articles 110-16, 110-17, and 110-18 of the National Electrical Code, ANSI/NFPA 70.

Grounding Cable and Lug Specifications for ACX7100-48L

For installations that require a separate grounding conductor to the chassis, you must ground the router properly before you connect power to ensure proper operation and to meet safety and electromagnetic interference (EMI) requirements. To ground an ACX7100-48L router, connect a grounding cable to earth ground, and then attach the grounding cable to the chassis grounding points.



WARNING: The router is a pluggable type A equipment installed in a restricted-access location. It has a separate protective earthing terminal provided on the chassis and on the DC power supply module in addition to the grounding pin of the AC power supply cord. You must keep this separate protective earthing terminal permanently connected to earth ground for installations that require a separate grounding conductor to the chassis.



WARNING: To comply with GR-1089 requirements, all intra-building copper cabling used for SFP+ and QSFP+ ports must be shielded and grounded at both ends.



CAUTION: Before you install the router, a licensed electrician must attach a cable lug to the grounding cables that you supply. See "[Connect Earth Ground to ACX7100-48L Routers](#)" on page 90. A cable with an incorrectly attached lug can damage the router.

Before you connect the router to earth ground, review the following information:

- The grounding points are in the form of studs that are sized for #10-32 screws. You need to provide these screws with integrated washers as we do not ship them in the accessory kit.
- For ACX7100-48L routers, the grounding lug required is a Panduit LCD10-10A-L or equivalent. The grounding lug accommodates 14–10 AWG (2–5.3mm²), stranded wire.

Clearance Requirements for Hardware Maintenance of ACX7100-48L Routers

When planning the site for installing an ACX7100-48L router, you must allow sufficient clearance around the installed chassis (see [Figure 18 on page 50](#)).

Figure 18: Clearance Requirements for Airflow and Hardware Maintenance for ACX7100-48L Routers

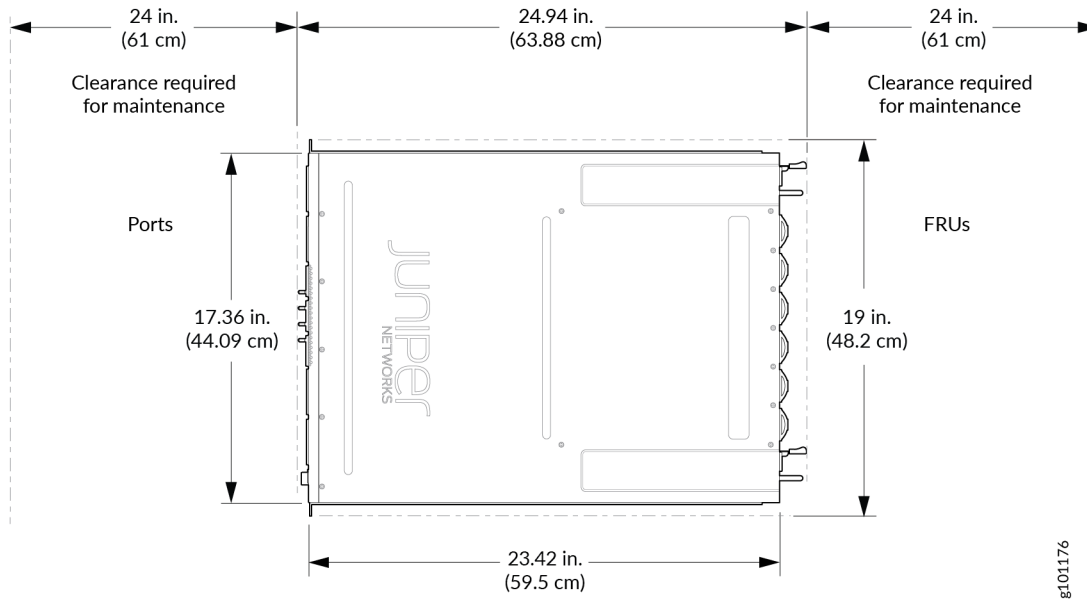

- For the cooling system to function properly, the airflow around the chassis must be unrestricted. See ["Cooling System and Airflow in ACX7100-48L Routers" on page 27](#) for more information about the airflow through the chassis.
- If you are mounting an ACX7100-48L router in a rack that has other equipment installed, ensure that the exhaust from other equipment does not blow into the intake vents of the chassis.
- Leave at least 6 in. (15.2 cm) clearance at the front and rear of the chassis for airflow and to accommodate the interface and power cable bend radius.
- Leave adequate space at the front and rear of the router for service personnel to remove and install hardware components. Allow at least 24 in. (61 cm) of space both at the front and the rear of the router.

Rack Requirements for ACX7100-48L Routers

ACX7100-48L routers are designed to be installed on four-post racks. [Table 22 on page 51](#) provides the rack requirements and specifications for ACX7100-48L routers.

Table 22: Rack Requirements for ACX7100-48L Routers

Rack Requirement	Guidelines
Rack type	<p>Use a four-post rack that provides bracket holes or hole patterns that are spaced at 1-U increments (1.75 in. or 4.45 cm), and ensure that the rack meets the size and strength requirements to support the weight.</p> <p>A U is the standard rack unit defined in <i>Cabinets, Racks, Panels, and Associated Equipment</i> (document number EIA-310-D) published by the Electronics Industry Association.</p>
Size, airflow, and clearance requirements	<ul style="list-style-type: none"> • If you are mounting an ACX7100-48L flush with the front posts of a rack, ensure that the distance between the front posts and the rear posts is between 23.2 in. (59 cm) and 30.5 in. (77.5 cm) • If you are mounting an ACX7100-48L in a recessed position from the front posts of a rack, ensure that the distance between the front posts and the rear posts is between 25.2 in. (64 cm) and 32.5 in. (82.6cm).
Rack size and strength	<ul style="list-style-type: none"> • Ensure that the rack complies with the standards for a 19-in. rack as defined in <i>Cabinets, Racks, Panels, and Associated Equipment</i> (document number EIA-310-D) published by the Electronics Industry Association. • Use an 800-mm rack as defined in the four-part <i>Equipment Engineering (EE) European telecommunications standard for equipment practice</i> (document numbers ETS 300 119-1 through 119-4) published by the European Telecommunications Standards Institute (http://www.etsi.org). <p>The horizontal spacing between the rails in a rack that complies with this standard is usually wider than the device's mounting brackets, which measure 19 in. (48.26 cm) from outer edge to outer edge. Use approved wing devices to narrow the opening between the rails as required.</p> <ul style="list-style-type: none"> • Ensure that the rack rails are spaced widely enough to accommodate the external dimensions of the router chassis. The outer edges of the front-mounting brackets extend the width to 19 in. (48.26 cm). • Ensure that the rack is strong enough to support the weight of the router. The fully configured ACX7100-48L router weighs about 26.94 lb (12.22 kg). • Ensure that the spacing of rails and adjacent racks allows for proper clearance around the router and rack.

Table 22: Rack Requirements for ACX7100-48L Routers (Continued)

Rack Requirement	Guidelines
Rack connection to building structure	<ul style="list-style-type: none"> Secure the rack to the building structure. If earthquakes are a possibility in your geographical area, secure the rack to the floor. Secure the rack to the ceiling brackets and to wall or floor brackets for maximum stability.

Cabinet Requirements for ACX7100-48L Routers

You can mount ACX7100-48L routers in a cabinet that contains a four-post 19-in. rack as defined in *Cabinets, Racks, Panels, and Associated Equipment* (document number EIA-310-D) published by the Electronics Industry Association.

[Table 23 on page 52](#) provides the cabinet requirements and specifications for ACX7100-48L routers.

Table 23: Cabinet Requirements and Specifications for ACX7100-48L Routers

Cabinet Requirements	Specifications
Cabinet size and clearance	The minimum total clearance inside the cabinet is 6 in. (15.2 cm) between the inside of the front door and the inside of the rear door.
Type and strength	<p>The cabinet must contain a four-post rack that provides bracket holes or hole patterns spaced at 1-U (1.75 in. or 4.45 cm) increments and that meets the size and strength requirements to support the weight. The minimum cabinet size from post to post for accommodating an ACX7100 router is 23.6 in. (60.0 cm) deep.</p> <p>A U is the standard rack unit defined in <i>Cabinets, Racks, Panels, and Associated Equipment</i> (document number EIA-310-D) published by the Electronics Industry Association.</p>

Table 23: Cabinet Requirements and Specifications for ACX7100-48L Routers (Continued)

Cabinet Requirements	Specifications
Size, airflow, and clearance requirements	<ul style="list-style-type: none"> • If you are mounting an ACX7100-48L flush with the front posts of a rack inside the cabinet, ensure that the distance between the front posts and the rear posts is between 23.2 in. (59 cm) and 30.5 in. (77.5 cm). • If you are mounting an ACX7100-48L in a recessed position from the front posts of a rack inside the cabinet, ensure that the distance between the front posts and the rear posts is between 25.2 in. (64 cm) and 32.5 in. (82.6 cm). • When you mount the device in a cabinet, ensure that ventilation through the cabinet is sufficient to prevent overheating. • Ensure that the cold air supply you provide through the cabinet adequately dissipates the thermal output of the switch (or switches). • Ensure that the cabinet allows the hot exhaust air from the switch to exit the cabinet without recirculating into the chassis. An open cabinet (without a top or doors) that employs hot air exhaust extraction from the top allows the best airflow through the chassis. If the cabinet contains a top or doors, perforations in these elements assist with removing the hot air exhaust. • Route and dress all cables to minimize the blockage of airflow to and from the chassis. • Ensure that the spacing of rails and adjacent cabinets allows for the proper clearance around the switch and cabinet.
Connection to building structure	<ul style="list-style-type: none"> • Secure the cabinet to the building structure. • If your geographical area is earthquake-prone, secure the cabinet to the floor. • Secure the cabinet to the ceiling brackets as well as wall or floor brackets for maximum stability.

RELATED DOCUMENTATION

| [Site Preparation Checklist for ACX7100-48L Routers](#) | 43

ACX7100-48L Network Cable and Transceiver Planning

IN THIS SECTION

- [Determining Transceiver Support for ACX7100-48L | 54](#)
- [Cable and Connector Specifications for ACX7100-48L | 55](#)
- [Calculating Power Budget and Power Margin for Fiber-Optic Cables | 62](#)
- [Fiber-Optic Cable Signal Loss, Attenuation, and Dispersion | 65](#)

Determining Transceiver Support for ACX7100-48L

You can find information about the pluggable transceivers and connector types that are supported on your Juniper Networks device by using the Hardware Compatibility Tool. The tool also documents the optical and cable characteristics, where applicable, for each transceiver. You can search for transceivers by product—and the tool displays all the transceivers supported on that device—or by category, interface speed, or type.

You can find the list of supported transceivers for the ACX7100-48L at <https://apps.juniper.net/hct/product/>. To know the speeds supported by each port on the ACX7100-48L, use the [Port Checker Tool](#).



CAUTION: If you face a problem running a Juniper Networks device that uses a third-party optic or cable, the Juniper Networks Technical Assistance Center (JTAC) can help you diagnose the source of the problem. Your JTAC engineer might recommend that you check the third-party optic or cable and potentially replace it with an equivalent Juniper Networks optic or cable that is qualified for the device.

Cable and Connector Specifications for ACX7100-48L

IN THIS SECTION

- [12-Fiber MPO Connectors | 55](#)
- [24-Fiber MPO Connectors | 61](#)
- [CS Connector | 61](#)
- [LC Duplex Connectors | 62](#)

The transceivers that are supported on the ACX7100-48L device use fiber-optic cables and connectors. The type of connector and the type of fiber depends on the transceiver type.

You can determine the type of cable and connector required for your specific transceiver by using the [Hardware Compatibility Tool](#).



CAUTION: To maintain agency approvals, use only a properly constructed, shielded cable.



NOTE: The terms multifiber push-on (MPO) and multifiber termination push-on (MTP) describe the same connector type. The rest of this topic uses MPO to mean MPO or MTP.

12-Fiber MPO Connectors

There are two types of cables used with 12-fiber MPO connectors on Juniper Networks devices—patch cables with MPO connectors on both ends, and breakout cables with an MPO connector on one end and four LC duplex connectors on the other end. Depending on the application, the cables might use single-mode fiber (SMF) or multimode fiber (MMF). Juniper Networks sells cables that meet the supported transceiver requirements, but you are not required to purchase cables from Juniper Networks.

Ensure that you order cables with the correct polarity. Vendors refer to these crossover cables as *key up to key up*, *latch up to latch up*, *Type B*, or *Method B*. If you are using patch panels between two transceivers, ensure that the proper polarity is maintained through the cable plant.

Also, ensure that the fiber end in the connector is finished correctly. Physical contact (PC) refers to fiber that has been polished flat. Angled physical contact (APC) refers to fiber that has been polished at an

angle. Ultra physical contact (UPC) refers to fiber that has been polished flat to a finer finish. The required fiber end is listed with the connector type in the [Hardware Compatibility Tool](#).

12-Fiber Ribbon Patch Cables with MPO Connectors

You can use 12-fiber ribbon patch cables with socket MPO connectors to connect two transceivers of the same type—for example, 40GBASE-SR4-to-40GBASESR4, or 100GBASE-SR4-to-100GBASE-SR4. You can also connect 4x10GBASE-LR or 4x10GBASE-SR transceivers by using patch cables—for example, 4x10GBASE-LR-to-4x10GBASE-LR, or 4x10GBASE-SR-to-4x10GBASE-SR—instead of breaking the signal out into four separate signals.

[Table 24 on page 56](#) describes the signals on each fiber. [Table 25 on page 57](#) shows the pin-to-pin connections for proper polarity.

Table 24: Cable Signals for 12-Fiber Ribbon Patch Cables

Fiber	Signal
1	Tx0 (Transmit)
2	Tx1 (Transmit)
3	Tx2 (Transmit)
4	Tx3 (Transmit)
5	Unused
6	Unused
7	Unused
8	Unused
9	Rx3 (Receive)
10	Rx2 (Receive)

Table 24: Cable Signals for 12-Fiber Ribbon Patch Cables (Continued)

Fiber	Signal
11	Rx1 (Receive)
12	Rx0 (Receive)

Table 25: Cable Pinouts for 12-Fiber Ribbon Patch Cables

MPO Pin	MPO Pin
1	12
2	11
3	10
4	9
5	8
6	7
7	6
8	5
9	4
10	3
11	2

Table 25: Cable Pinouts for 12-Fiber Ribbon Patch Cables (Continued)

MPO Pin	MPO Pin
12	1

12-Fiber Ribbon Breakout Cables with MPO-to-LC Duplex Connectors

You can use 12-fiber ribbon breakout cables with MPO-to-LC duplex connectors to connect a QSFP+ transceiver to four separate SFP+ transceivers—for example, 4x10GBASE-LR-to-10GBASE-LR, or 4x10GBASE-SR-to-10GBASE-SR SFP+ transceivers. The breakout cable is constructed out of a 12-fiber ribbon fiber-optic cable. The ribbon cable splits from a single cable with a socket MPO connector on one end, into four cable pairs with four LC duplex connectors on the other end.

[Figure 19 on page 58](#) shows an example of a typical 12-fiber ribbon breakout cable with MPO-to-LC duplex connectors (depending on the manufacturer, your cable might look different).

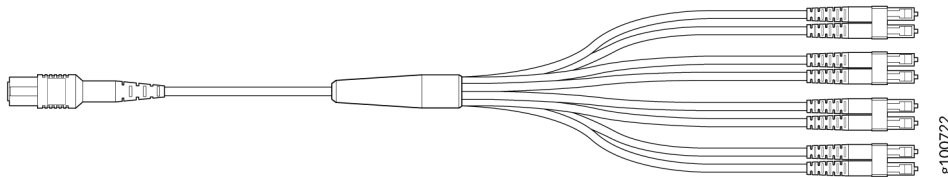
Figure 19: 12-Fiber Ribbon Breakout Cable

[Table 26 on page 58](#) describes the way the fibers are connected between the MPO and LC duplex connectors. The cable signals are the same as those described in [Table 24 on page 56](#).

Table 26: Cable Pinouts for 12-Fiber Ribbon Breakout Cables

MPO Connector Pin	LC Duplex Connector Pin
1	Tx on LC Duplex 1
2	Tx on LC Duplex 2
3	Tx on LC Duplex 3

Table 26: Cable Pinouts for 12-Fiber Ribbon Breakout Cables (Continued)

MPO Connector Pin	LC Duplex Connector Pin
4	Tx on LC Duplex 4
5	Unused
6	Unused
7	Unused
8	Unused
9	Rx on LC Duplex 4
10	Rx on LC Duplex 3
11	Rx on LC Duplex 2
12	Rx on LC Duplex 1

12-Ribbon Patch and Breakout Cables Available from Juniper Networks

Juniper Networks sells 12-ribbon patch and breakout cables with MPO connectors that meet the requirements described earlier. You are not required to purchase cables from Juniper Networks. [Table 27 on page 59](#) describes the available cables.

Table 27: 12-Ribbon Patch and Breakout Cables Available from Juniper Networks

Cable Type	Connector Type	Fiber Type	Cable Length	Juniper Model Number
12-ribbon patch	Socket MPO/PC to socket MPO/PC, key up to key up	MMF (OM3)	1 m	MTP12-FF-M1M

Table 27: 12-Ribbon Patch and Breakout Cables Available from Juniper Networks (Continued)

Cable Type	Connector Type	Fiber Type	Cable Length	Juniper Model Number
			3 m	MTP12-FF-M3M
			5 m	MTP12-FF-M5M
			10 m	MTP12-FF-M10M
	Socket MPO/APC to socket MPO/APC, key up to key up	SMF	1 m	MTP12-FF-S1M
			3 m	MTP12-FF-S3M
			5 m	MTP12-FF-S5M
			10 m	MTP12-FF-S10M
12-ribbon breakout	Socket MPO/PC, key up, to four LC/UPC duplex	MMF (OM3)	1 m	MTP-4LC-M1M
			3 m	MTP-4LC-M3M
			5 m	MTP-4LC-M5M
			10 m	MTP-4LC-M10M
	Socket MPO/APC, key up, to four LC/UPC duplex	SMF	1 m	MTP-4LC-S1M
			3 m	MTP-4LC-S3M
			5 m	MTP-4LC-S5M
			10 m	MTP-4LC-S10M

24-Fiber MPO Connectors

You can use patch cables with 24-fiber MPO connectors to connect two supported transceivers of the same type—for example, 2x100GE-SR-to-2x100GE-SR.

Figure 20 on page 61 shows the 24-fiber MPO optical lane assignments.

Figure 20: 24-Fiber MPO Optical Lane Assignments

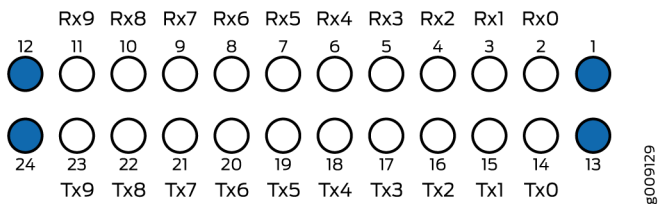

i **NOTE:** You must order cables with the correct polarity. Vendors refer to these crossover cables as *key up to key up*, *latch up to latch up*, *Type B*, or *Method B*. If you are using patch panels between two transceivers, ensure that the proper polarity is maintained through the cable plant.

The MPO optical connector for the CFP2-100G-SR10-D3 is defined in *Section 5.6* of the *CFP2 Hardware Specification* and *Section 88.10.3* of *IEEE STD 802.3-2012*. These specifications include the following requirements:

- Recommended Option A in IEEE STD 802.3-2012.
- The transceiver receptacle is a plug. A patch cable with a socket connector is required to connect to the module.
- Ferrule finish shall be a flat-polished interface that is compliant with IEC 61754-7.
- Alignment key is key up.

The optical interface must meet the FT-1435-CORE requirement in *Generic Requirements for Multi-Fiber Optical Connectors*. The module must pass the wiggle test defined by IEC 62150-3.

CS Connector

You can use patch cables with CS connectors to connect two supported transceivers of the same type—for example, 2x100G-LR4 to 2x100G-LR4 or 2x100G-CWDM4 to 2x100G-CWDM4. CS connectors are

compact connectors that are designed for next generation QSFP-DD transceivers. The CS connector provides easy backward compatibility with QSFP28 and QSFP56 transceivers.

LC Duplex Connectors

You can use patch cables with LC duplex connectors to connect two supported transceivers of the same type—for example, 40GBASE-LR4-to-40GBASE-LR4, or 100GBASE-LR4-to 100GBASE-LR4. A patch cable is one fiber pair with two LC duplex connectors at opposite ends. LC duplex connectors are also used with 12-fiber ribbon breakout cables.

Figure 21 on page 62 shows how to install an LC duplex connector in a transceiver.

Figure 21: LC Duplex Connector

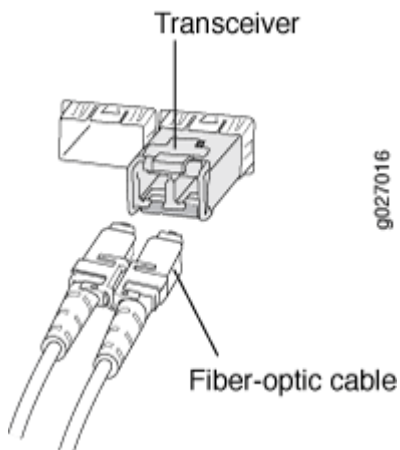

Calculating Power Budget and Power Margin for Fiber-Optic Cables

IN THIS SECTION

- [Calculate Power Budget for Fiber-Optic Cables | 63](#)
- [How to Calculate Power Margin for Fiber-Optic Cables | 63](#)

Use the information in this topic and the specifications for your optical interface to calculate the power budget and power margin for fiber-optic cables.



TIP: You can use the [Hardware Compatibility Tool](#) to find information about the pluggable transceivers supported on your Juniper Networks device.

To calculate the power budget and power margin, perform the following tasks:

Calculate Power Budget for Fiber-Optic Cables

To ensure that fiber-optic connections have sufficient power for correct operation, you need to calculate the link's power budget (P_B), which is the maximum amount of power it can transmit. When you calculate the power budget, you use a worst-case analysis to provide a margin of error, even though all the parts of an actual system do not operate at the worst-case levels. To calculate the worst-case estimate of P_B , you assume minimum transmitter power (P_T) and minimum receiver sensitivity (P_R):

$$P_B = P_T - P_R$$

The following hypothetical power budget equation uses values measured in decibels (dB) and decibels referred to one milliwatt (dBm):

$$P_B = P_T - P_R$$

$$P_B = -15 \text{ dBm} - (-28 \text{ dBm})$$

$$P_B = 13 \text{ dB}$$

How to Calculate Power Margin for Fiber-Optic Cables

After calculating a link's P_B , you can calculate the power margin (P_M), which represents the amount of power available after subtracting attenuation or link loss (LL) from the P_B . A worst-case estimate of P_M assumes maximum LL:

$$P_M = P_B - LL$$

P_M greater than zero indicates that the power budget is sufficient to operate the receiver.

Factors that can cause link loss include higher-order mode losses, modal and chromatic dispersion, connectors, splices, and fiber attenuation. [Table 28 on page 64](#) lists an estimated amount of loss for the factors used in the following sample calculations. For information about the actual amount of signal loss caused by equipment and other factors, refer to vendor documentation.

Table 28: Estimated Values for Factors Causing Link Loss

Link-Loss Factor	Estimated Link-Loss Value
Higher-order mode losses	Single mode—None Multimode—0.5 dB
Modal and chromatic dispersion	Single mode—None Multimode—None, if product of bandwidth and distance is less than 500 MHz-km
Faulty connector	0.5 dB
Splice	0.5 dB
Fiber attenuation	Single mode—0.5 dB/km Multimode—1 dB/km

The following sample calculation for a 2-km-long multimode link with a P_B of 13 dB uses the estimated values from [Table 28 on page 64](#). This example calculates LL as the sum of fiber attenuation (2 km @ 1 dB/km, or 2 dB) and loss for five connectors (0.5 dB per connector, or 2.5 dB) and two splices (0.5 dB per splice, or 1 dB) as well as higher-order mode losses (0.5 dB). The P_M is calculated as follows:

$$P_M = P_B - LL$$

$$P_M = 13 \text{ dB} - 2 \text{ km (1 dB/km)} - 5 (0.5 \text{ dB}) - 2 (0.5 \text{ dB}) - 0.5 \text{ dB}$$

$$P_M = 13 \text{ dB} - 2 \text{ dB} - 2.5 \text{ dB} - 1 \text{ dB} - 0.5 \text{ dB}$$

$$P_M = 7 \text{ dB}$$

The following sample calculation for an 8-km-long single-mode link with a P_B of 13 dB uses the estimated values from [Table 28 on page 64](#). This example calculates LL as the sum of fiber attenuation (8 km @ 0.5 dB/km, or 4 dB) and loss for seven connectors (0.5 dB per connector, or 3.5 dB). The pP_M is calculated as follows:

$$P_M = P_B - LL$$

$$P_M = 13 \text{ dB} - 8 \text{ km (0.5 dB/km)} - 7(0.5 \text{ dB})$$

$$P_M = 13 \text{ dB} - 4 \text{ dB} - 3.5 \text{ dB}$$

$$P_M = 5.5 \text{ dB}$$

In both the examples, the calculated P_M is greater than zero, indicating that the link has sufficient power for transmission and does not exceed the maximum receiver input power.

Fiber-Optic Cable Signal Loss, Attenuation, and Dispersion

IN THIS SECTION

- [Signal Loss in Multimode and Single-Mode Fiber-Optic Cable | 65](#)
- [Attenuation and Dispersion in Fiber-Optic Cable | 65](#)

Signal Loss in Multimode and Single-Mode Fiber-Optic Cable

Multimode fiber is large enough in diameter to allow rays of light to reflect internally (bounce off the walls of the fiber). Interfaces with multimode optics typically use LEDs as light sources. However, LEDs are not coherent sources. They spray varying wavelengths of light into the multimode fiber, which reflects the light at different angles. Light rays travel in jagged lines through a multimode fiber, causing signal dispersion. When light traveling in the fiber core radiates into the fiber cladding, higher-order mode loss results. Together these factors limit the transmission distance of multimode fiber compared with single-mode fiber.

Single-mode fiber is so small in diameter that rays of light can reflect internally through one layer only. Interfaces with single-mode optics use lasers as light sources. Lasers generate a single wavelength of light, which travels in a straight line through the single-mode fiber. Compared with multimode fiber, single-mode fiber has a higher bandwidth and can carry signals for longer distances.

Exceeding the maximum transmission distances can result in significant signal loss, which causes unreliable transmission.

Attenuation and Dispersion in Fiber-Optic Cable

Correct functioning of an optical data link depends on modulated light reaching the receiver with enough power to be demodulated correctly. *Attenuation* is the reduction in power of the light signal as it is transmitted. Attenuation is caused by passive media components such as cables, cable splices, and connectors. Although attenuation is significantly lower for optical fiber than for other media, it still

occurs in both multimode and single-mode transmission. An efficient optical data link must have enough light available to overcome attenuation.

Dispersion is the spreading of the signal over time. The following two types of dispersion can affect an optical data link:

- Chromatic dispersion—Spreading of the signal over time, resulting from the different speeds of light rays.
- Modal dispersion—Spreading of the signal over time, resulting from the different propagation modes in the fiber.

For multimode transmission, modal dispersion—rather than chromatic dispersion or attenuation—usually limits the maximum bit rate and link length. For single-mode transmission, modal dispersion is not a factor. However, at higher bit rates and over longer distances, chromatic dispersion rather than modal dispersion limits maximum link length.

An efficient optical data link must have enough light to exceed the minimum power that the receiver requires to operate within its specifications. In addition, the total dispersion must be less than the limits specified for the type of link in Telcordia Technologies document GR-253-CORE (Section 4.3) and International Telecommunications Union (ITU) document G.957.

When chromatic dispersion is at the maximum allowed, its effect can be considered as a power penalty in the power budget. The optical power budget must allow for the sum of component attenuation, power penalties (including those from dispersion), and a safety margin for unexpected losses.

RELATED DOCUMENTATION

[ACX7100-48L System Overview | 8](#)

[Port Panel of ACX7100-48L Routers | 17](#)

ACX7100-48L Management and Console Port Specifications and Pinouts

IN THIS SECTION

- [Management Cable Specifications for ACX7100 Routers | 67](#)

- [Management Port Connector Pinout Information for ACX7100 | 67](#)
- [Console Port Connector Pinout on ACX7100 Routers | 68](#)
- [USB Port Specifications for ACX7100 | 69](#)

Management Cable Specifications for ACX7100 Routers

[Table 29 on page 67](#) lists the specifications for the cables that connect the console and management ports to management devices.

Table 29: Specifications of Cables to Connect to Management Devices

Ports	Cable Specifications	Receptacle	Additional Information
RJ-45 Console (CON) port	RS-232 (EIA-232) serial cable	RJ-45	<i>Connect a Device to a Management Console by Using an RJ-45 Connector</i>
Management (MGMT) port	Ethernet cable with an RJ-45 connector	RJ-45	<i>Connect a Device to a Network for Out-of-Band Management</i>

Management Port Connector Pinout Information for ACX7100

The management port—labeled **MGMT**—on an ACX7100 uses an RJ-45 connector to connect to a management device for out-of-band management.

The port uses an autosensing RJ-45 connector to support a 10/100BASE-T connection.

[Table 30 on page 68](#) provides the pinout information for the RJ-45 connector for the management port.

Table 30: Management Port Connector Pinout Information

Pin	Description	Direction
1	TRP1+	Transmit/receive data pair 1
2	TRP1-	Transmit/receive data pair 1
3	TRP2+	Transmit/receive data pair 2
4	TRP3+	Transmit/receive data pair 3
5	TRP3-	Transmit/receive data pair 3
6	TRP2-	Transmit/receive data pair 2
7	TRP4+	Transmit/receive data pair 4
8	TRP4-	Transmit/receive data pair 4

Console Port Connector Pinout on ACX7100 Routers

The port labeled **CON** on the front panel is an RS-232 serial interface that uses an RJ-45 connector to connect to a console management device. The default baud rate for the console port is 9600 baud.

Use a cable with the pinouts described in [Table 31 on page 69](#) to connect an ACX7100 to a console management device.



NOTE: If your laptop or PC does not have a DB-9 plug connector pin and you want to connect your laptop or PC directly to an ACX7100, use a combination of the RJ-45 cable and RJ-45 to DB-9 adapter and a USB to DB-9 plug adapter. You must provide the USB to DB-9 plug adapter.

Table 31: Console Port and TOD Connector Pinouts for the ACX7100

Pin	Signal	Description
1	N/C	Not Connected
2	DSR Output TOD Output	Data set ready Time of Day (TOD) for Precision Time Protocol (PTP) applications. You can use DSR pins as a TOD universal asynchronous receiver/transmitter (UART) by using a breakout cable.
3	RxD Input	Receive data
4	Signal Ground	Signal ground
5	Signal Ground	Signal ground
6	TxD Output	Transmit data
7	TOD Output	Time of Day (TOD) for Precision Time Protocol (PTP) applications. You can use DTR pins as a TOD universal asynchronous receiver/transmitter (UART) by using breakout cables.
8	N/C	Not Connected

USB Port Specifications for ACX7100

The USB flash drives that you use with the ACX7100 must support USB 2.0 or later.



CAUTION: Remove the USB flash drive before upgrading Junos OS Evolved or rebooting an ACX7100. Failure to do so could cause the router to behave unpredictably.

RELATED DOCUMENTATION

| [Management Panel of ACX7100-48L Routers](#) | 15

4

CHAPTER

Initial Installation and Configuration

[ACX7100-48L Installation Overview](#) | 72

[Unpack and Mount an ACX7100-48L Router](#) | 72

[Connect ACX7100-48L to Power](#) | 89

[Connect ACX7100-48L to External Devices](#) | 99

[Perform Initial Software Configuration for the ACX7100-48L Routers](#) | 103

ACX7100-48L Installation Overview

To install and connect an ACX7100-48L router:

1. Follow the instructions in ["Unpack an ACX7100-48L Router" on page 72](#).
2. Determine how the device is to be mounted.
For instructions on mounting, see ["Mount an ACX7100-48L Router in a Rack" on page 74](#).
3. Follow the instructions in:
 - a. ["Connect Earth Ground to ACX7100-48L Routers" on page 90](#).
 - b. ["Connect AC Power to an ACX7100-48L Router" on page 93](#) or ["Connect DC Power to an ACX7100-48L Router" on page 95](#), as required.
4. ["Perform Initial Software Configuration for the ACX7100-48L Routers" on page 103](#).

Unpack and Mount an ACX7100-48L Router

IN THIS SECTION

- [Unpack an ACX7100-48L Router | 72](#)
- [Register Products—Mandatory to Validate SLAs | 74](#)
- [Mount an ACX7100-48L Router in a Rack | 74](#)
- [Mount an ACX7100-48L Router in a Rack or Cabinet by Using the JNP-4PST-RMK-1U-E Rack Mount Kit | 78](#)

Unpack an ACX7100-48L Router

The ACX7100-48L router chassis is a rigid sheet-metal structure that houses the hardware components. An ACX7100-48L router is shipped in a cardboard carton, secured with foam packing material. The carton also contains an accessory box and quick start instructions.



CAUTION: ACX7100-48L routers are maximally protected inside the shipping carton. Do not unpack the router until you are ready to begin installation.

To unpack an ACX7100-48L router:

1. Move the shipping carton to a staging area as close to the installation site as possible, where you have enough room to remove the system components.
2. Position the carton so that the arrows are pointing up.
3. Open the top flaps on the shipping carton.
4. Remove the accessory box, and verify the contents against the inventory included in the box.
5. Pull out the packing material that is holding the router in place.
6. Verify the chassis components that you received.
7. Save the shipping carton and packing materials in case you need to move or ship the router later.

Table 32: ACX7100-48L Router Parts List

Component	Quantity
Chassis with six fan modules and two PSMs	1
AC power cord (generic, type C15 coupler)	2
Breakout cable to simultaneously connect to a console and to a time of day (TOD) device	1
Power cord retainers	2
Four-post rack mounting kit	1
Documentation roadmap card	1



NOTE: We no longer include the RJ-45 console cable with the DB-9 adapter as part of the device package. If the console cable and adapter are not included in your device package, or if you need a different type of adapter, you can order the following separately:

- RJ-45 to DB-9 adapter (JNP-CBL-RJ45-DB9)
- RJ-45 to DB-9 adapter (JNP-CBL-RJ45-DB9)
- RJ-45 to USB-C adapter (JNP-CBL-RJ45-USBC)

If you want to use RJ-45 to USB-A or RJ-45 to USB-C adapter you must have X64 (64-Bit) Virtual COM port (VCP) driver installed on your PC. See, <https://ftdichip.com/drivers/vcp-drivers/> to download the driver.

Register Products—Mandatory to Validate SLAs

Register all new Juniper Networks hardware products and changes to an existing installed product using the Juniper Networks website. Registering products and changes to products activates your hardware replacement service-level agreements (SLAs).



CAUTION: Register product serial numbers on the Juniper Networks website. Update the installation base data if any installation base data is added or changed or if the installation base is moved. Juniper Networks will not be held accountable for customers not meeting the hardware replacement service-level agreement (SLA) for products that do not have registered serial numbers or accurate installation base data.

Register your product or products at <https://tools.juniper.net/svcreg/SRegSerialNum.jsp>.

Update your installation base at <https://www.juniper.net/customers/csc/management/updateinstallbase.jsp>.

Mount an ACX7100-48L Router in a Rack

IN THIS SECTION

- [Before You Begin Rack Installation | 75](#)
- [Install an ACX7100-48L Router in a Rack | 76](#)

You can mount an ACX7100-48L router on a rack by using the mounting kit provided with the device.

Before You Begin Rack Installation

Before you begin mounting an ACX7100-48L router in the rack:

1. Ensure that you understand how to prevent electrostatic discharge (ESD) damage. See "[Prevention of Electrostatic Discharge Damage](#)" on page 174.
2. Verify that the site meets the requirements described in "[Site Preparation Checklist for ACX7100-48L Routers](#)" on page 43.
3. Place the rack in its permanent location, allowing adequate clearance for airflow and maintenance, and secure it to the building structure.
4. Read *General Site Guidelines*, with particular attention to "[Chassis and Component Lifting Guidelines](#)" on page 156.
5. Remove the router from the shipping carton. See "[Unpack an ACX7100-48L Router](#)" on page 72.
6. Ensure that you have the following parts and tools available to mount the router in a rack:
 - ESD grounding strap (not provided)
 - One pair of front-mounting rails (provided)
 - Screws to secure the mounting rails to the chassis (provided)
 - Phillips(+) screwdriver, number 1 and number 2, for the mounting screws (not provided)
 - Two power cords with plugs appropriate for your geographical location (provided)
 - RJ-45 cable and RJ-45 to DB-9 serial port adapter (not provided)
 - Management host, such as a PC laptop, with a serial port (not provided)



NOTE: We no longer include the RJ-45 console cable with the DB-9 adapter as part of the device package. If the console cable and adapter are not included in your device package, or if you need a different type of adapter, you can order the following separately:

- RJ-45 to DB-9 adapter (JNP-CBL-RJ45-DB9)
- RJ-45 to DB-9 adapter (JNP-CBL-RJ45-DB9)
- RJ-45 to USB-C adapter (JNP-CBL-RJ45-USBC)

If you want to use RJ-45 to USB-A or RJ-45 to USB-C adapter you must have X64 (64-Bit) Virtual COM port (VCP) driver installed on your PC. See, <https://ftdichip.com/drivers/vcp-drivers/> to download the driver.



CAUTION: If you are mounting multiple units on a rack, mount the heaviest unit at the bottom of the rack and mount the other units from the bottom of the rack to the top in decreasing order of the weight of the units.

Install an ACX7100-48L Router in a Rack

To install the router in a four-post rack:

1. Position the router in front of the rack.
2. Wrap and fasten one end of the ESD grounding strap around your bare wrist, and connect the other end of the strap to a site ESD point.
3. Align the holes in the front-mounting rails with the holes on the side of the chassis (see [Figure 22 on page 76](#)).

Figure 22: Install the Mounting Rails on an ACX7100-48L Router

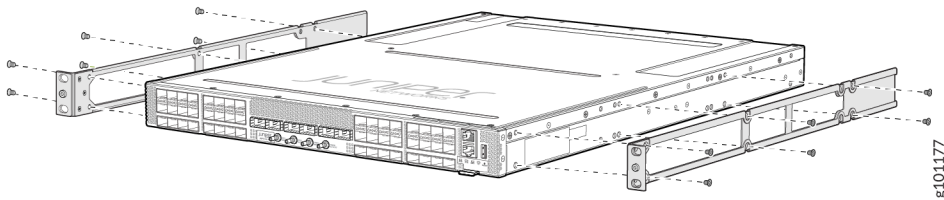

4. Using a Phillips (+) number 1 screwdriver, secure the mounting rails to the chassis using the mounting screws.
5. With one person on each side, hold on to the bottom of the chassis, and carefully lift the chassis so that the mounting rails are aligned with the rack rails.
6. Carefully slide the chassis with the rails attached on to the rack rails (see [Figure 23 on page 76](#)).

Figure 23: Install the ACX7100-48L Router in a Four-Post Rack

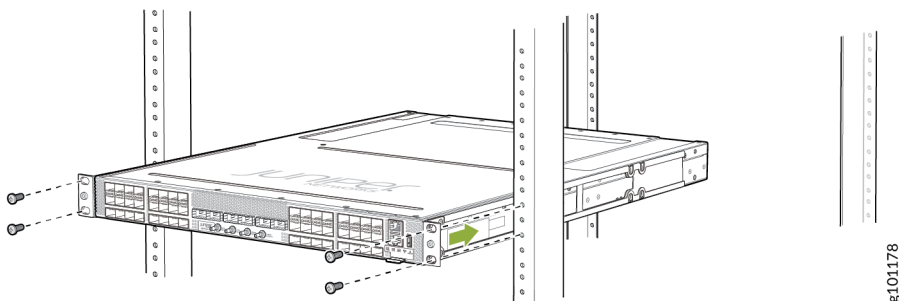

7. Install mounting screws into each of the front-mounting bracket holes aligned with the rack, starting from the bottom, and tighten the screws. [Figure 24 on page 77](#) shows the router fully secured to the front rails of the four-post rack.

Figure 24: ACX7100-48L Router Secured by Front-Mounting Brackets

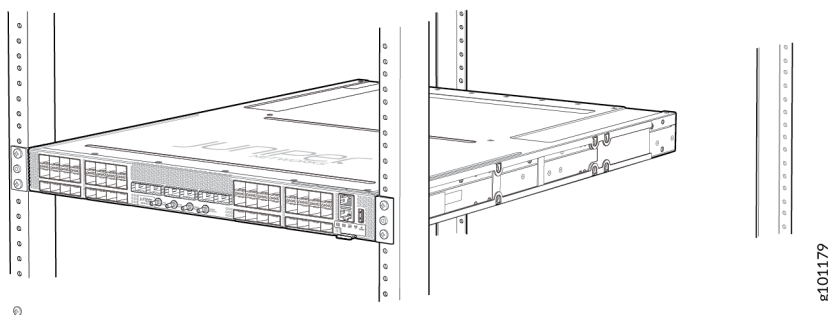

8. On the rear of the chassis, slide the rear-mounting blades on either side of the chassis until the rear-mounting brackets at the end of the blades contact the rack rails (see [Figure 25 on page 77](#)). The rear-mounting blades on each side of the chassis are movable. You can adjust the length of the blades according to the depth of the rack.

Figure 25: Install the Rear-Mounting Blades on an ACX7100-48L Router

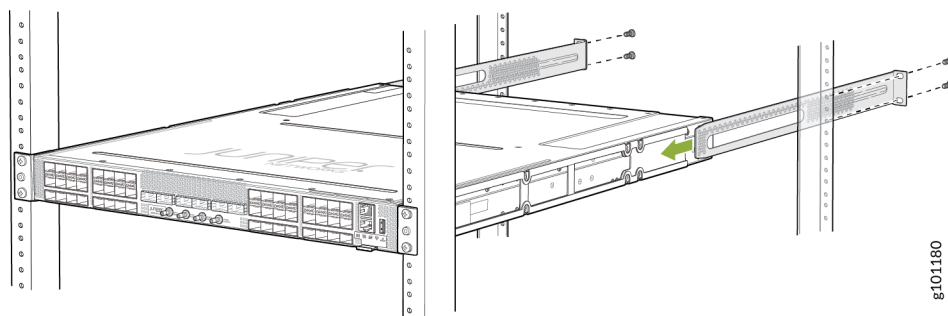

9. Install mounting screws into each of the rear-mounting bracket holes aligned with the rack, starting from the bottom, and secure them tightly. Apply 5.0 to 5.5 lb-in of torque to the screws.
10. Visually inspect the alignment of the chassis.

If you've installed the chassis properly in the rack, all the mounting screws on one side of the rack are aligned with the mounting screws on the opposite side, and the router is level. [Figure 26 on page 78](#) shows the router fully secured and installed in a four-post rack.

Figure 26: ACX7100-48L Router Installed in a Four-Post Rack

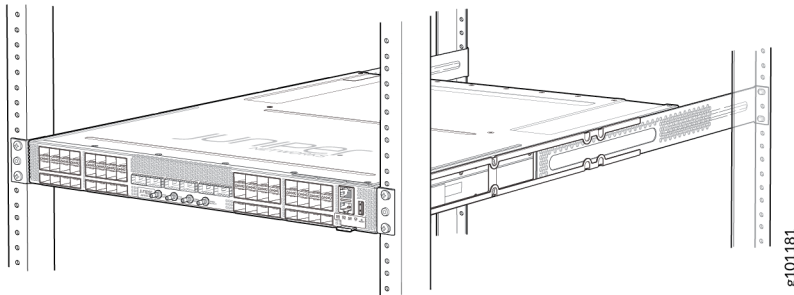

SEE ALSO

[Rack Requirements for ACX7100-48L Routers | 50](#)

Mount an ACX7100-48L Router in a Rack or Cabinet by Using the JNP-4PST-RMK-1U-E Rack Mount Kit

IN THIS SECTION

- [Mount the Device by Using the JNP-4PST-RMK-1U-E Rack Mount Kit On a Square Hole Rack | 79](#)
- [Mount the Device by Using the JNP-4PST-RMK-1U-E Rack Mount Kit On a Threaded Hole Rack | 83](#)

You can mount ACX7100-48L Routers on a square hole or threaded hole four-post 19-in. racks using the partial tool less JNP-4PST-RMK-1U-E rack mount kit.

JNP-4PST-RMK-1U-E rack mount kit consists of the following parts:

- A pair of front and rear mounting rails
- A pair of mounting brackets
- 16 flat head M4 x 6mm Phillips screws

A four-post installation evenly supports the device by all four corners.

Mount the Device by Using the JNP-4PST-RMK-1U-E Rack Mount Kit On a Square Hole Rack

Ensure that you have the following tools and parts available:

- An ESD grounding strap—not provided.
- Number 2 Phillips (+) screwdriver—not provided
- A pair of front and rear mounting rails that attach to the rack posts—provided with the rack mount kit
- A pair of mounting brackets and 16 flat head M4 x 6mm Phillips screws. These brackets attach to the device if not pre-installed—provided with the rack mount kit

To mount the device on four posts in a rack by using the JNP-4PST-RMK-1U-E rack mount kit:

1. Wrap and fasten the ESD grounding strap to your bare wrist and then connect the other end of the strap to the ESD point on the device.
2. Assemble the mounting rails.
 - a. Slide the rear floating bracket into the front bracket. See [Figure 27 on page 79](#).

Figure 27: Assemble the Mounting Rails

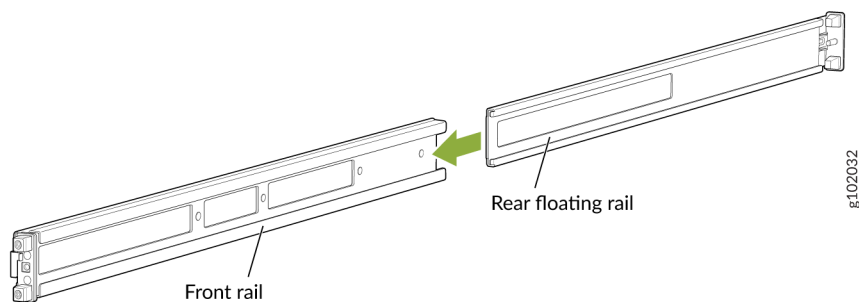

- b. Mounting rails assembled. See [Figure 28 on page 80](#).

Figure 28: Front and Rear Rails Assembled

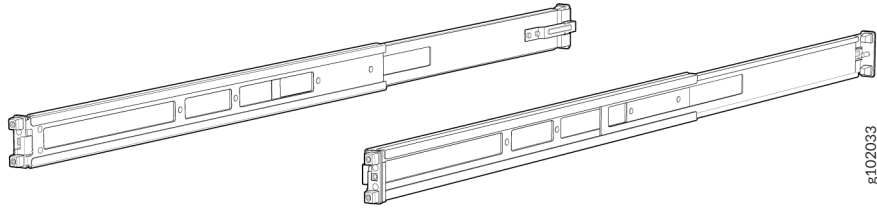

3. Attach the mounting rails to the rack.

- a. Align the guide blocks of the rear mounting rails with the rear-post holes. Pull the rear mounting rails toward the front of the rack to lock the rails in place. You will hear a click sound when the latch locks into the corresponding rack holes. See [Figure 29 on page 80](#).

Figure 29: Install the Rear Floating Rails

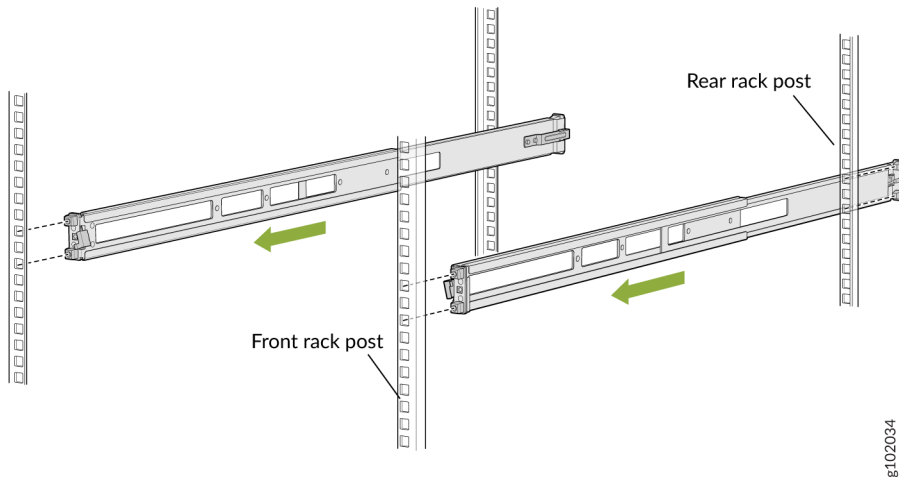

- b. Move the latch lock on the front mounting rails to open position, slide the front mounting rails, and insert the guide blocks into the front rack posts. See [Figure 30 on page 81](#).

Figure 30: Install the Front Mounting Rails

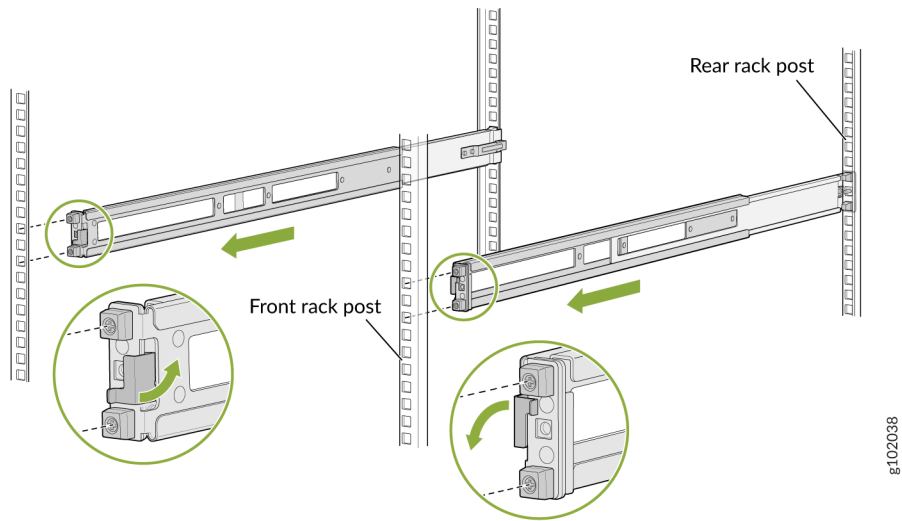

- c. Push the lock latch to the locked position. See [Figure 31 on page 81](#).

Figure 31: Front Mounting Rails Lock Latch

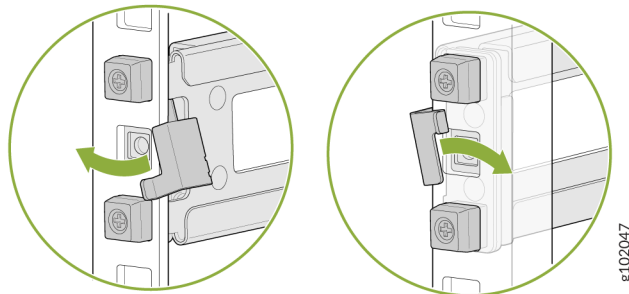

- d. Visually ensure that the front and rear latches are locked into place on the mounting rails. See [Figure 32 on page 82](#).

Figure 32: Mounting Rails Installed and Locked

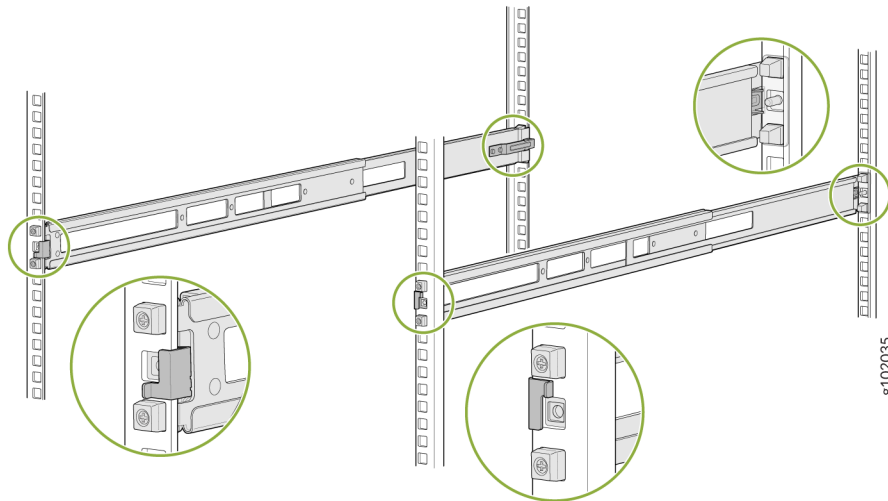

4. Attach mounting brackets to the device if not pre-installed. If your device already has the mounting brackets pre-installed than skip this step and move to the next step.
 - a. Align the holes on the mounting bracket with the screw holes on the side panel of the chassis.
 - b. Insert the flat head M4 x 6mm Phillips screws to attach the mounting bracket into the aligned holes on the chassis (see [Figure 33 on page 82](#)). Tighten the screws.

Figure 33: Attach the Mounting Brackets to the Device

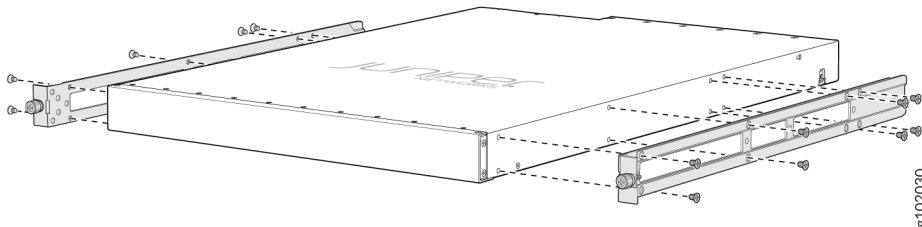

5. Position the device in such a manner that the **AIR OUT** labels on components are next to the hot aisle.
6. Grasp both sides of the device, lift it, and position the device such that the mounting rails slide into the channels of the mounting brackets. See [Figure 34 on page 83](#).

Figure 34: Slide the Device into the Rack

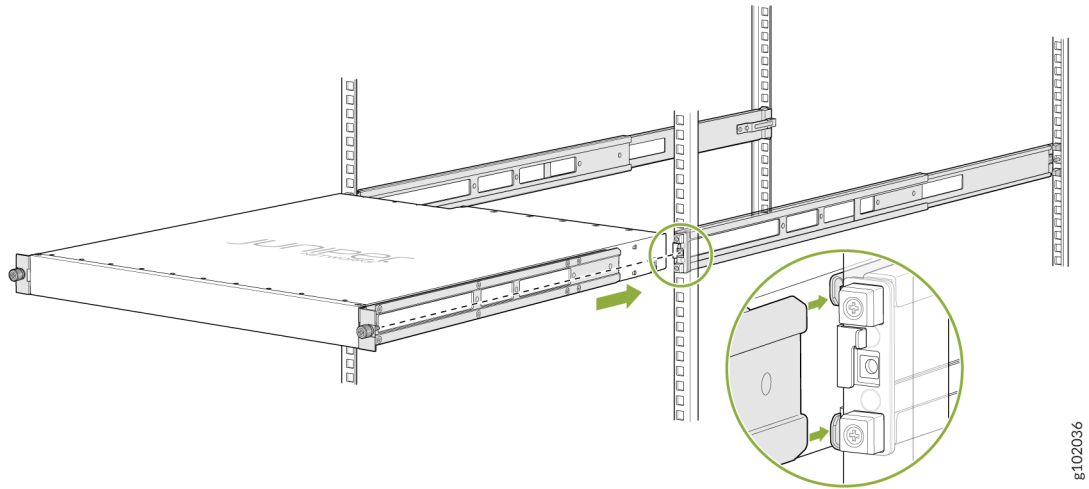

7. Tighten the two thumbscrews to secure the device. See [Figure 35 on page 83](#).

Figure 35: Tighten the Thumb Screws

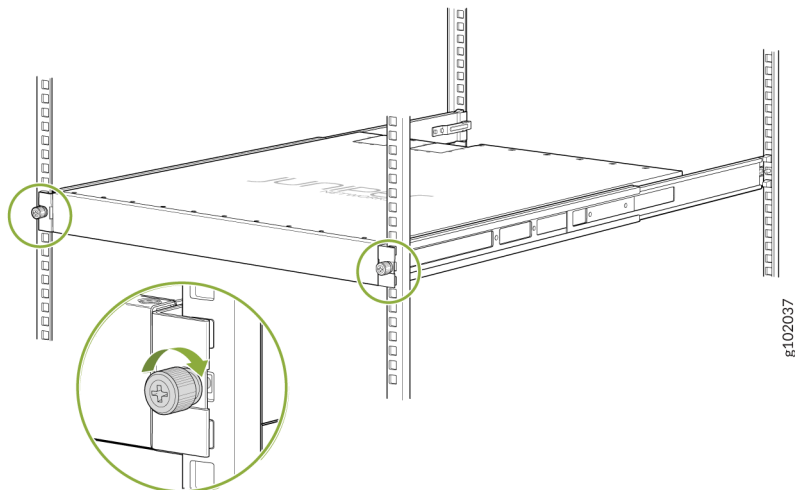

Mount the Device by Using the JNP-4PST-RMK-1U-E Rack Mount Kit On a Threaded Hole Rack

Ensure that you have the following tools and parts available:

- An ESD grounding strap—not provided
- Number 2 Phillips (+) screwdriver—not provided

- A pair of front and rear mounting rails that attach to the rack posts—provided with the rack mount kit
- A pair of side mounting brackets and 16 flat head M4 x 6mm Phillips screws. These brackets attach to the device if not pre-installed—provided with the rack mount kit

To mount the device on four posts in a threaded hole rack by using the JNP-4PST-RMK-1U-E rack mount kit:

1. Wrap and fasten the ESD grounding strap to your bare wrist and connect the other end of the strap to the ESD point on the device.
2. Assemble the mounting rails.
 - a. Remove the guide blocks from the front mounting rails by loosening the screws and preserve them for later use. See [Figure 36 on page 84](#).

Figure 36: Remove Guide Blocks from Front Mounting Rail

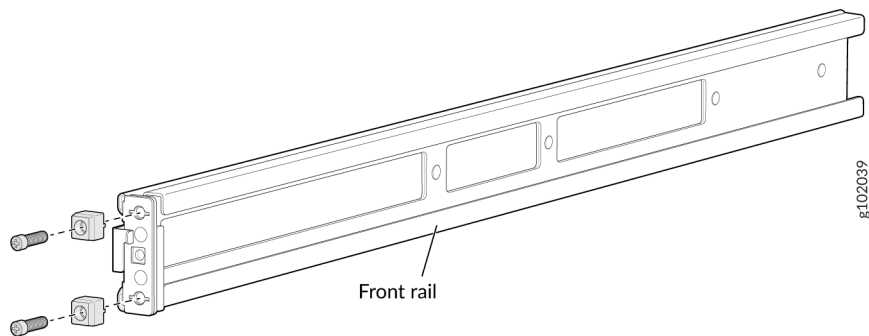

- b. Remove the guide blocks from the rear floating rails by loosening the screws and washers. Preserve the guide blocks, screws, and washers for later use. See [Figure 37 on page 84](#)

Figure 37: Remove Guide Blocks from Rear Floating Rail

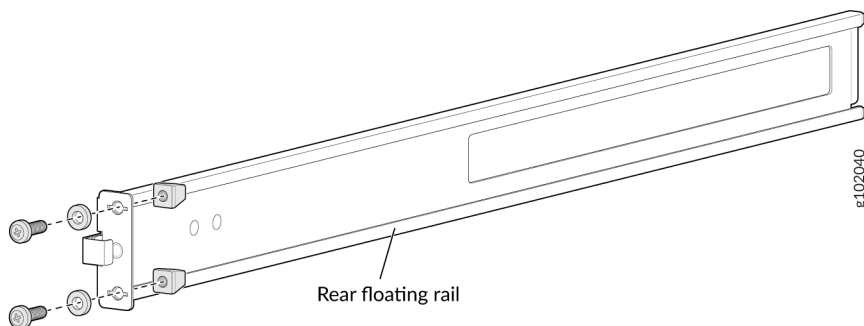

- c. Slide the rear floating rails into the front mounting rails. See [Figure 38 on page 85](#).

Figure 38: Slide Rear Floating Rail into Front Mounting Rail

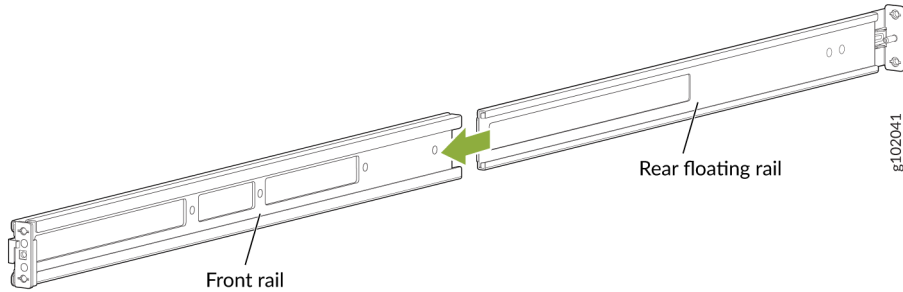

- d. Mounting rails assembled. See [Figure 39 on page 85](#).

Figure 39: Front and Rear Rails Assembled

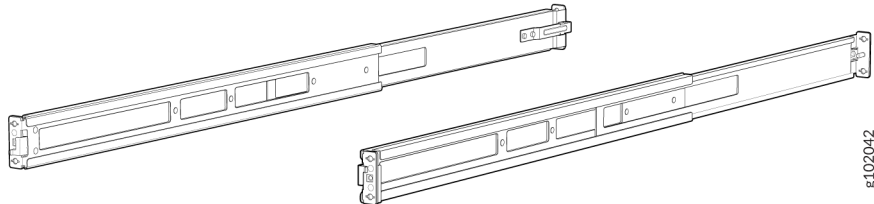

- 3. Attach the mounting rails to the threaded hole rack.**
- Align the guide blocks of the rear mounting rails with the rear-post holes. Pull the rear mounting rails toward the front of the rack to lock the rails in place. You will hear a click sound when the latch locks into the corresponding rack holes. See [Figure 40 on page 86](#).

Figure 40: Install the Rear Floating Rails

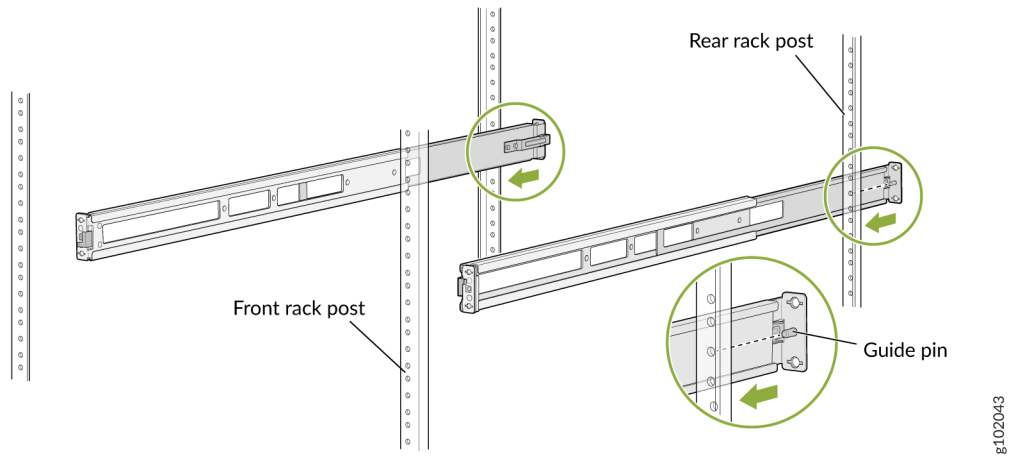

- b. Move the latch locks on the front mounting rails to open position, slide the front mounting rails and align them to the front rack post. Push the lock latch to locked position and using the screws removed in step 2.a and the washers removed in step 2.b, secure the front mounting rails to the front rack post. See [Figure 41 on page 86](#).

Figure 41: Install the Front Mounting Rails

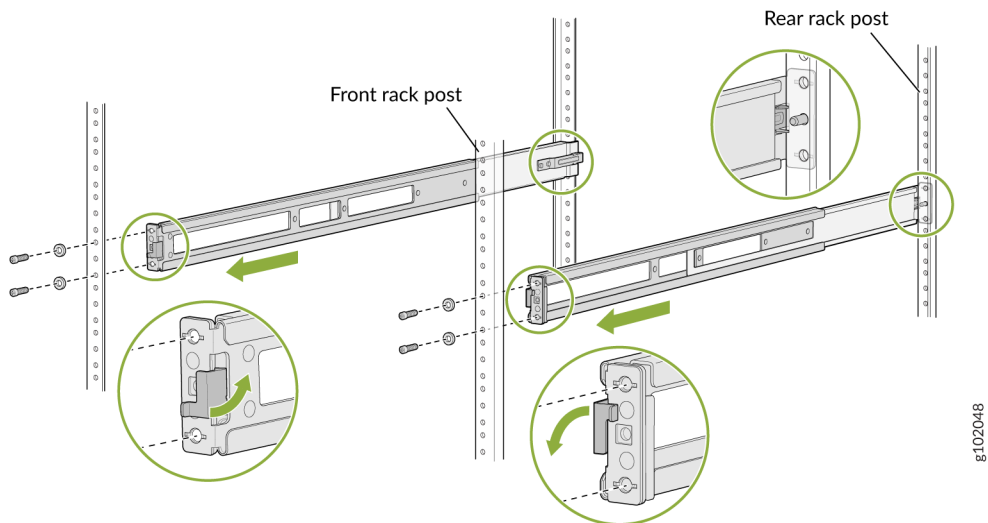

- c. Secure the rear floating rails to the rear rack post by using screws (not provided) appropriate for your rack threaded size. See [Figure 42 on page 87](#).

Figure 42: Secure the Rear Floating Rails

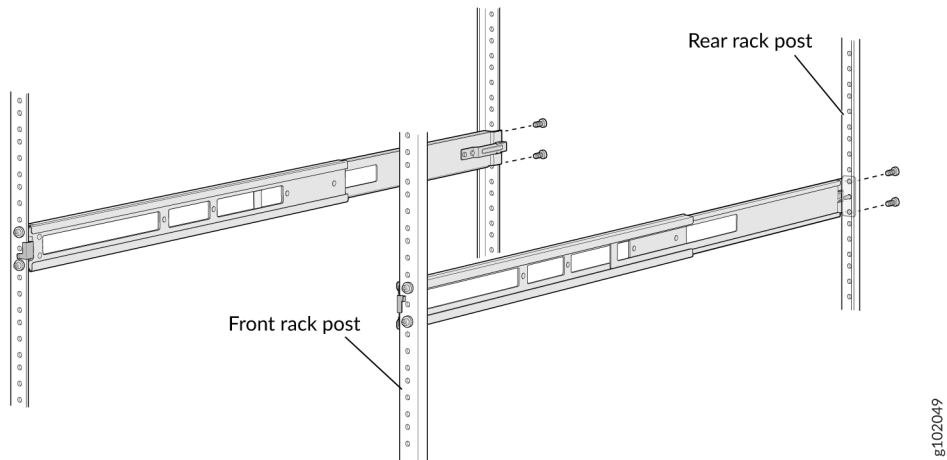

- d. Visually ensure that the front and rear latches are locked into place on the mounting rails. See [Figure 43 on page 87](#).

Figure 43: Mounting Rails Installed and Secured

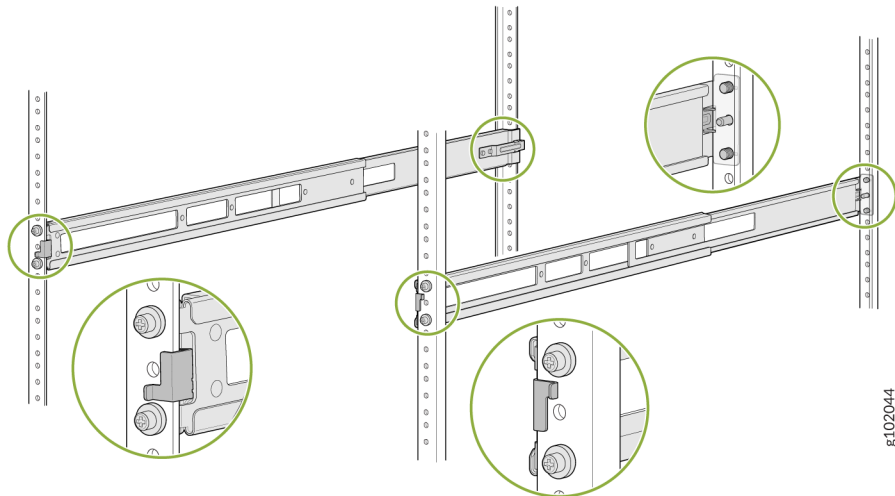

4. Attach mounting brackets to the device if not pre-installed. If your device already has the mounting brackets pre-installed than skip this step and move to the next step.
 - a. Align the holes on the mounting bracket with the screw holes on the side panel of the chassis.
 - b. Insert the flat head M4 x 6mm Phillips screws to attach the mounting bracket into the aligned holes on the chassis (see [Figure 44 on page 88](#)). Tighten the screws.

Figure 44: Attach the Mounting Brackets to the Device

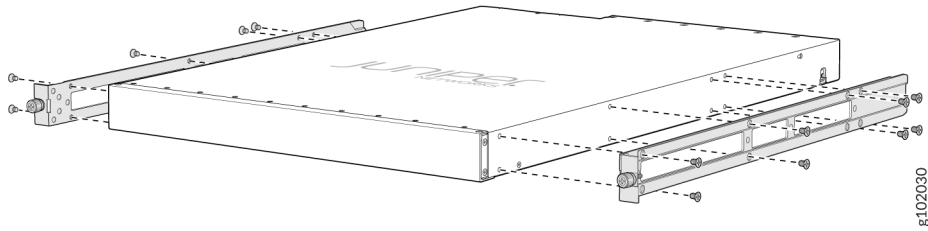

5. Position the device in such a manner that the **AIR OUT** labels on components are next to the hot aisle.
6. Grasp both sides of the device, lift it, and position the device such that the mounting rails slide into the channels of the mounting brackets. See [Figure 45 on page 88](#).

Figure 45: Slide the Device into the Rack

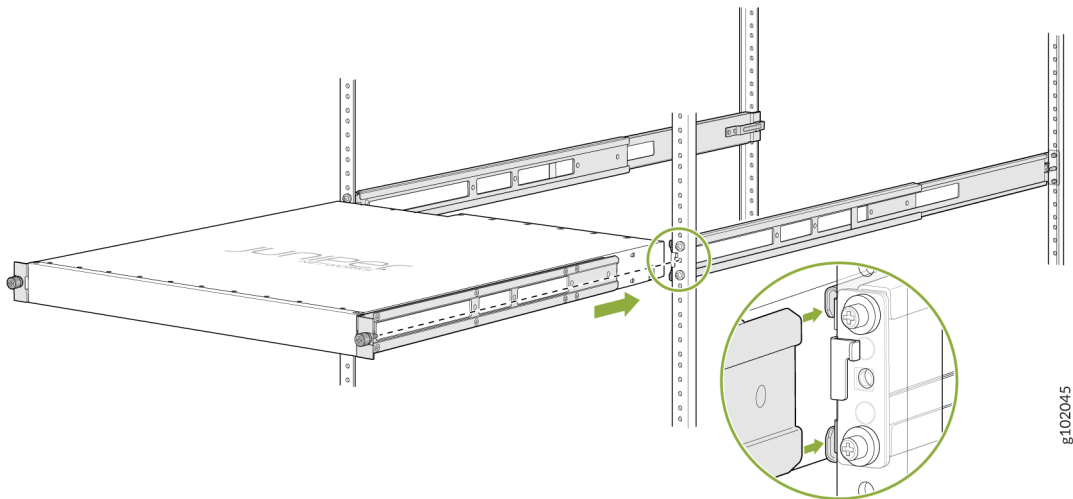

7. Tighten the two thumbscrews to secure the device. See [Figure 46 on page 89](#).

Figure 46: Tighten Thumb Screws

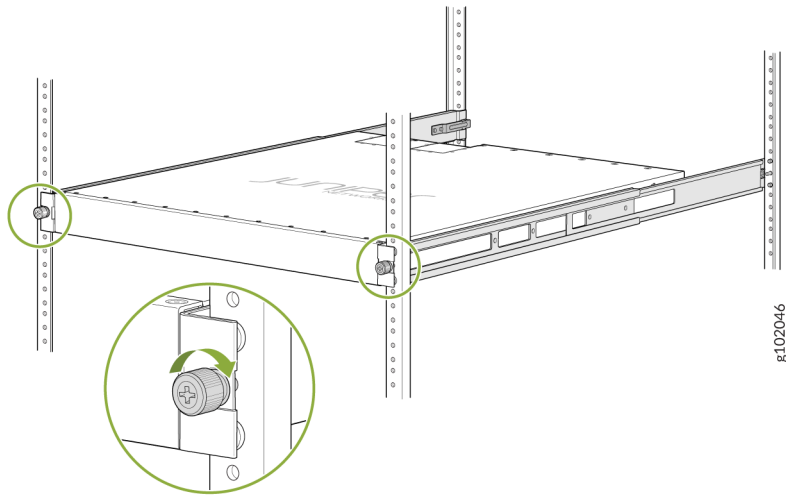

RELATED DOCUMENTATION

[ACX7100-48L Installation Overview | 72](#)

[Connect Earth Ground to ACX7100-48L Routers | 90](#)

Connect ACX7100-48L to Power

IN THIS SECTION

- [Connect Earth Ground to ACX7100-48L Routers | 90](#)
- [Connect AC Power to an ACX7100-48L Router | 93](#)
- [Connect DC Power to an ACX7100-48L Router | 95](#)

Connect Earth Ground to ACX7100-48L Routers

IN THIS SECTION

- [Connect Earth Ground to ACX7100-48L Routers | 90](#)
- [Connect Earth Ground to DC PSM Protective Earthing Terminal | 92](#)

To meet safety and electromagnetic interference (EMI) requirements and to ensure proper operation, you must ground the router properly before connecting power. The ACX7100-48L routers have a separate protective earthing terminal provided on the chassis and on the DC power supply module (PSM) in addition to the grounding pin of the AC PSM cord.

You must install the ACX7100-48L in a restricted-access location and ensure that the chassis is always properly grounded. The ACX7100-48L has a two-hole protective grounding terminal provided on the chassis. See [Figure 48 on page 92](#). Under all circumstances, use this grounding connection to ground the chassis. For AC-powered systems, you must also use the grounding wire in the AC power cord along with the two-hole grounding lug connection. This tested system meets or exceeds all applicable EMC regulatory requirements with the two-hole protective grounding terminal.

To connect earth ground to ACX7100-48L routers, see "[Connect Earth Ground to ACX7100-48L Routers](#)" on page 90. However, if you are unable to access the chassis grounding point by using the two-holed grounding lug, you can ground the chassis using the DC protective earthing terminal on the DC PSM.

Connect Earth Ground to ACX7100-48L Routers

To meet safety and electromagnetic interference (EMI) requirements and to ensure proper operation, you must ground the router properly before connecting power.

Before you connect earth ground to the protective earthing terminal of a ACX7100-48L router, ensure that a licensed electrician has attached an appropriate grounding lug to the grounding cable.

[Figure 47 on page 91](#) shows the grounding points on ACX7100-48L routers.

Figure 47: Grounding Points on the ACX7100-48L Router

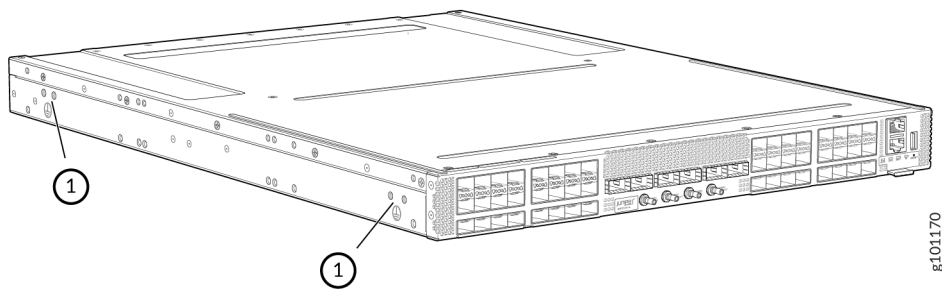

1– Grounding points

The grounding points are in the form of studs that are sized for #10-32 screws. (You need to provide these screws with integrated washers as we do not ship them in the accessory kit).

You ground the router by connecting one end of a grounding cable to earth ground and then attaching the other end to the chassis grounding points by using #10-32 screws. You must provide the grounding cables.



NOTE: The grounding lug required is a Panduit LCD10-10A-L or equivalent (not provided). The grounding lug accommodates 14–10 AWG (2–5.3 mm²) stranded wire. The grounding cable that you provide for the chassis must be the same size or heavier than the input wire of each power supply. Minimum recommendation is 14–10 AWG (2–5.3 mm²) stranded wire for the ACX7100-48L router

To ground the ACX7100-48L router:

1. Verify that a licensed electrician has attached the cable lug provided with the router to the grounding cable.
2. Ensure that all grounding surfaces are clean and brought to a bright finish before grounding connections are made.
3. Connect the grounding cable to a proper earth ground.
4. Place the grounding cable lug over the grounding points on the side of the chassis (see [Figure 48 on page 92](#)).

Figure 48: Connect the Grounding Cable to the ACX7100-48L Router

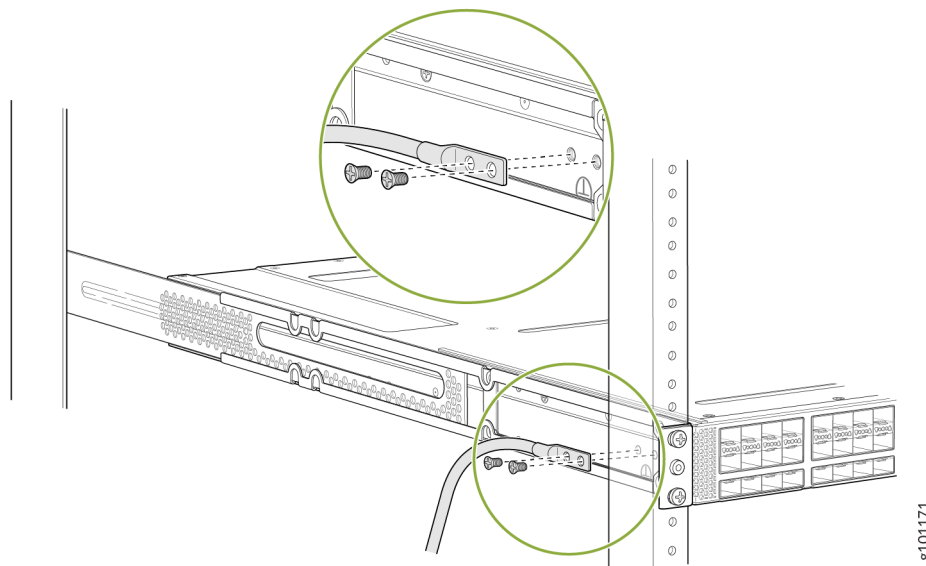

5. Secure the grounding cable lug with the screws. Apply 30-33 lb-in of torque to the screws.
6. Dress the grounding cable and verify that it does not touch or block access to router components, and that it does not drape where people could trip over it.

Connect Earth Ground to DC PSM Protective Earthing Terminal

You attach the protective earthing terminal lug to the DC PSM protective earthing terminal to provide a protective earthing connection.

You ground the DC PSM protective earthing terminal by connecting one end of a grounding cable to earth ground and then attaching the other end to the protective earthing terminal on the DC PSM by using a #10-32 screw. You must provide the grounding cables.



NOTE: The protective earthing terminal lug accommodates 14-10 AWG (2-5.3 mm²) standard wire. The grounding cable that you provide for the protective earthing terminal of the DC PSM must be of the same size or heavier than the input wire of each PSM. The minimum recommendations for the ACX7100-48L router are 14-10 AWG (2-5.3 mm²) standard wire.

To ground the chassis using the protective earthing terminal on the DC PSM:

1. Verify that a licensed electrician has attached the cable lug provided with the router to the grounding cable.
2. Ensure that all grounding surfaces are clean and brought to a bright finish before grounding connections are made.

3. Connect the grounding cable to a proper earth ground.
4. Place the grounding cable lug over the protective earthing terminal on the DC PSM.
5. Secure the grounding cable lug with #10-32 screw.
6. Dress the grounding cable and verify that it does not touch or block access to router components, and that it does not drape where people could trip over it.

Connect AC Power to an ACX7100-48L Router

Ensure that you have a power cord appropriate for your geographical location available to connect AC power to the router.

Before you begin connecting AC power to the router:

- Ensure that you have taken the necessary precautions to prevent electrostatic discharge (ESD) damage (see "[Prevention of Electrostatic Discharge Damage](#)" on page 174).
- Ensure that you have connected the router chassis to earth ground.



CAUTION: Before you connect power to the router, a licensed electrician must attach a cable lug to the grounding and power cables that you supply. A cable with an incorrectly attached lug can damage the router (for example, by causing a short circuit). To meet safety and electromagnetic interference (EMI) requirements and to ensure proper operation, you must connect the chassis to earth ground before you connect it to power. Under all circumstances, use the protective earthing terminal on the router chassis to connect to the earth ground. The router gains additional grounding when you plug the PSM in the router to a grounded AC power outlet by using the AC power cord appropriate for your geographical location.

- Install the PSM in the chassis.

The power supply module (PSM) in an ACX7100-48L router is a hot-removable and hot-insertable field-replaceable unit (FRU). You can remove and replace it without powering off the router or disrupting routing functions.



NOTE: You must connect each PSM to a dedicated power source outlet.

To connect AC power to an ACX7100-48L router:

1. Wrap and fasten one end of the ESD grounding strap around your bare wrist, and connect the other end of the strap to the ESD point on the chassis.

2. Power off the AC input appliance inlet on the source power supply.
3. Connect the power cord to the power source outlet.



NOTE: Each power supply must be connected to a dedicated AC power feed and a dedicated customer-site 2-pole circuit breaker. We recommend that you use a dedicated customer-site circuit breaker rated for 20 A (110 VAC) or 16 A (220 VAC) minimum, or as required by local code.

4. Push the end of the AC power cord retainer strip into the hole next to the inlet on the power supply faceplate on the router until it snaps into place. Ensure that the loop in the retainer strip faces toward the power cord (see [Figure 49 on page 94](#)).

Figure 49: Insert Power Cord Retainer Strip on the AC PSM

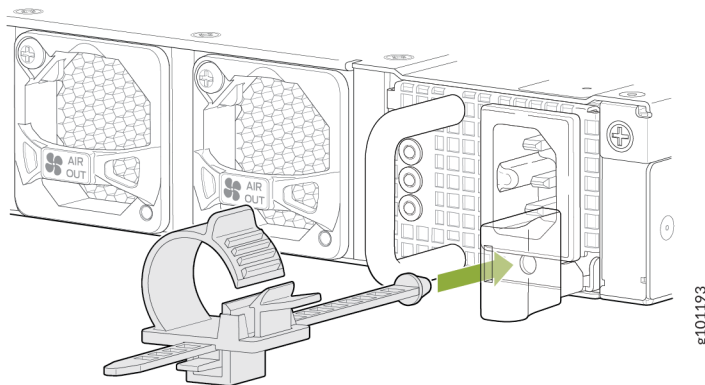

5. Press the small tab on the retainer strip to loosen the loop. Slide the loop until you have enough space to insert the power cord coupler into the inlet.
6. Insert the power cord coupler firmly into the inlet.
7. Slide the loop toward the PSM until it is snug against the base of the coupler.
8. Press the tab on the loop and draw out the loop into a tight circle (see [Figure 50 on page 95](#)).
9. Route the power cord appropriately. Verify that the power cord does not block the air exhaust and access to router components, or drape where people could trip over it.
10. Power on the source power supply.
11. Repeat [Step 3](#) through [Step 9](#) for installing the remaining PSM.

Figure 50: Connect an AC Power Cord to an ACX7100-48L

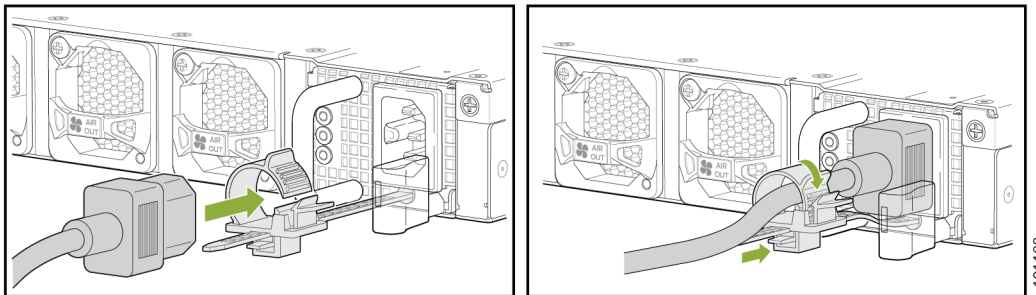

Connect DC Power to an ACX7100-48L Router

Before you begin connecting DC power to the router:

- Ensure that you have taken the necessary precautions to prevent electrostatic discharge (ESD) damage (see "[Prevention of Electrostatic Discharge Damage](#)" on page 174).
- Ensure that you have connected the router chassis to earth ground.



CAUTION: Before you connect power to the router, a licensed electrician must attach a cable lug to the grounding and power cables that you supply. A cable with an incorrectly attached lug can damage the router (for example, by causing a short circuit). To meet safety and electromagnetic interference (EMI) requirements and to ensure proper operation, you must connect the chassis to earth ground before you connect it to power. Under all circumstances, use the protective earthing terminal on the router chassis to connect to the earth ground.

- Install the PSM in the chassis.

Ensure that you have the following parts and tools available:

- Phillips (+) screwdriver, number 2 (not provided)
- Multimeter (not provided)

The power supply module (PSM) in an ACX7100-48L router is a hot-removable and hot-insertable field-replaceable unit (FRU). You can remove and replace it without powering off the router or disrupting routing functions.



WARNING: DC-powered ACX7100-48L routers are intended for installation only in a restricted-access location.



NOTE: The battery returns of the DC power supply must be connected as an isolated DC return (DC-I).

To connect DC power to an ACX7100-48L router:

1. Wrap and fasten one end of the ESD grounding strap around your bare wrist, and connect the other end of the strap to the ESD point on the chassis.
2. Verify that the DC power cables are correctly labeled before making connections to the power supply. In a typical power distribution scheme where the return is connected to chassis ground at the battery plant, you can use a multimeter to verify the resistance of the -48V and RTN DC cables to chassis ground:
 - The cable with very low resistance (indicating a closed circuit) to chassis ground is positive (+). You install this cable on the V+ (return) DC power input terminal.
 - The cable with very high resistance (indicating an open circuit) to chassis ground is negative (-). You install this cable on the V- (input) DC power input terminal.



CAUTION: You must ensure that power connections maintain the proper polarity. The power source cables might be labeled (+) and (-) to indicate their polarity. There is no standard color coding for DC power cables. The color coding used by the external DC power source at your site determines the color coding for the leads on the power cables that attach to the DC power input terminals on each PSM.

3. Install heat-shrink tubing insulation around the power cables.

To install heat-shrink tubing:

- a. Slide the tubing over the portion of the cable where it is attached to the lug barrel. Ensure that tubing covers the end of the wire and the barrel of the lug attached to it.
- b. Shrink the tubing with a heat gun. Ensure that you heat all sides of the tubing evenly so that it shrinks around the cable tightly.

Figure 51 on page 97 shows the steps to install heat-shrink tubing.



NOTE: Do not overheat the tubing.

Figure 51: How to Install Heat-Shrink Tubing

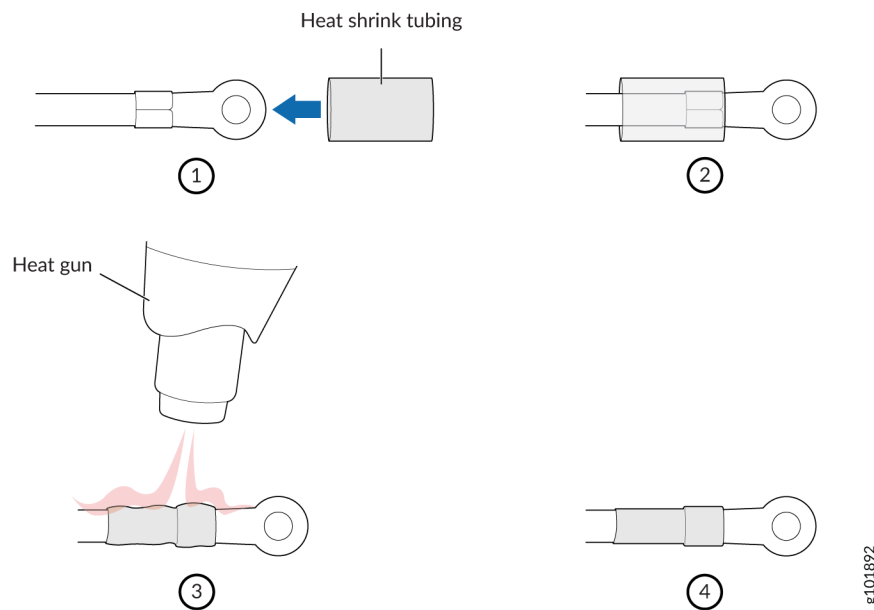

4. Ensure that the input circuit breaker is open so that the voltage across the DC power source cable leads is 0 V and that the cable leads do not become active while you are connecting DC power.



NOTE: The V+ terminals are referred to as +RTN, and V- terminals are referred to as -48 V in "[DC Power Wiring Sequence Warning](#)" on page 181.

5. Ensure that the PSMs are fully inserted in the chassis.
6. Remove the terminal block cover. The terminal block cover is a piece of clear plastic that snaps into place over the terminal block (see [Figure 52](#) on page 99).
7. Remove the screws on the terminals by using the screwdriver. Save the screws.



WARNING: Ensure that the power cables do not block access to device components or drape where people can trip over them.

8. Connect each PSM to the power sources. Secure power source cables to the PSMs by screwing the ring lugs attached to the cables to the appropriate terminals by using the screw from the terminals (see [Figure 52](#) on page 99).



NOTE: Ring lug required is a KST P/N: RNYBS8-4 or equivalent (not provided).

The ACX7100-48L router is designed to operate with a DC PSM that has a single, non-redundant, feed input. For source redundancy, you must install two DC PSMs in the ACX7100-48L; connect source (A) to one PSM and source (B) to the second PSM. This configuration provides the commonly deployed A/B feed redundancy for the system.



CAUTION: The connection between each power source and PSM must include a circuit breaker. We recommend that you use a customer-site 2-pole circuit breaker rated for 25A, or as required by local electrical code.

Do not connect two sources to a single PSM because doing so can potentially cause circulating current in feed wires whenever there is any difference in the voltage of the two sources.



NOTE: To connect the DC source to an ACX7100-48L router, use a 10-12 AWG wire.

- a. Secure the ring lug of the positive (+) DC power source cable to the V+ terminal on the DC PSM.
 - b. Secure the ring lug of the negative (-) DC power source cable to the V- terminal on the DC PSM.
 - c. Tighten the screws on the PSM terminals until snug using the screwdriver. Do not overtighten the screws.
9. Replace the terminal block cover.
 10. Close the input circuit breaker.



NOTE: The switch powers on as soon as power is provided to the PSM. There is no power switch on the device.

11. Verify that the **IN** and **OUT** LEDs on the PSM are lit green and are on steadily.

Figure 52: Connect DC Power Cable to an ACX7100-48L Router

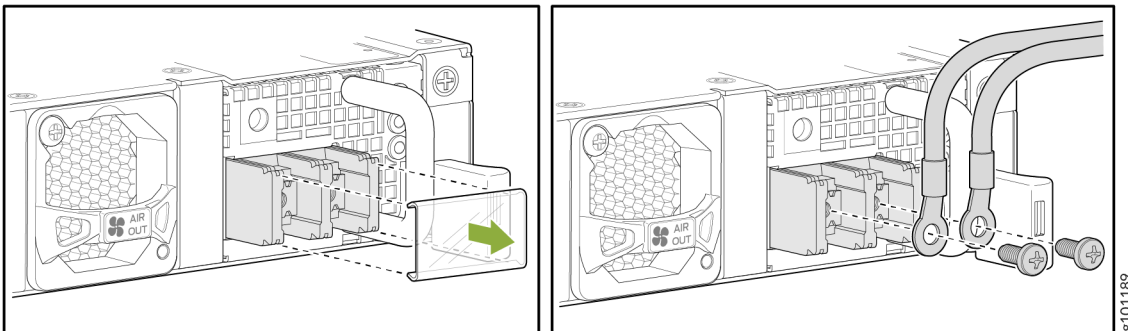

RELATED DOCUMENTATION

[ACX7100-48L Power System | 32](#)

[Maintaining the ACX7100-48L Power Supplies | 111](#)

Connect ACX7100-48L to External Devices

IN THIS SECTION

- [Connect an ACX7100-48L Router to a Management Console | 99](#)
- [Connect an ACX7100-48L Router to a Network for Out-of-Band Management | 101](#)
- [Connect an ACX7100-48L Router to External Clocking and Timing Devices | 102](#)

Connect an ACX7100-48L Router to a Management Console

Ensure that you have an RJ-45 to DB-9 rollover cable available.



NOTE: We no longer include the RJ-45 console cable with the DB-9 adapter as part of the device package. If the console cable and adapter are not included in your device

package, or if you need a different type of adapter, you can order the following separately:

- RJ-45 to DB-9 adapter (JNP-CBL-RJ45-DB9)
- RJ-45 to DB-9 adapter (JNP-CBL-RJ45-DB9)
- RJ-45 to USB-C adapter (JNP-CBL-RJ45-USBC)

If you want to use RJ-45 to USB-A or RJ-45 to USB-C adapter you must have X64 (64-Bit) Virtual COM port (VCP) driver installed on your PC. See, <https://ftdichip.com/drivers/vcp-drivers/> to download the driver.



NOTE: If your laptop or PC does not have a DB-9 pin contact and you want to connect your laptop or PC directly to the ACX7100-48L router, use a combination of the RJ-45 cable and RJ-45 to DB-9 adapter and a USB to DB-9 plug adapter. You must provide the USB to DB-9 plug adapter.

The ACX7100-48L routers have a console port with an RJ-45 connector. Use the console port to connect the device to a management console or to a console server.

To connect the ACX7100-48L router to a management console (see [Figure 53 on page 100](#) and [Figure 54 on page 101](#)):

1. Connect one end of the Ethernet cable to the console port (labeled **CON**).
2. Connect the other end of the Ethernet cable into the console server (see [Figure 53 on page 100](#)) or management console (see [Figure 54 on page 101](#)).

Figure 53: Connecting the ACX7100-48L Router to a Management Console Through a Console Server

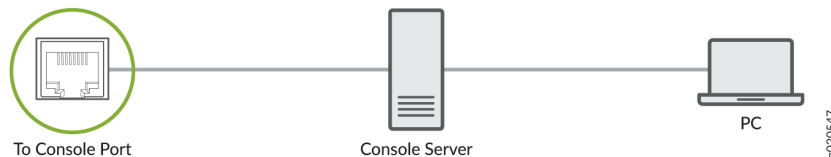

Figure 54: Connecting the ACX7100-48L Router Directly to a Management Console



Connect an ACX7100-48L Router to a Network for Out-of-Band Management

Ensure that you have an appropriate cable available. See ["ACX7100-48L Network Cable and Transceiver Planning"](#) on page 54.

You can monitor and manage the ACX7100-48L router by using a dedicated management channel. Use the management ports to connect the ACX7100-48L router to a network for out-of-band management.



NOTE: You cannot use the management ports to perform the initial configuration of the ACX7100-48L router. You must configure the management ports before you can successfully connect to the ACX7100-48L router using these ports. See ["Perform Initial Software Configuration for the ACX7100-48L Routers"](#) on page 103.

To connect an ACX7100-48L router to a network for out-of-band management (see [Figure 55 on page 102](#)):

1. Connect one end of the cable to one of the management ports (labeled **MGMT** on the ACX7100-48L router).
2. Connect the other end of the cable to the management PC (see [Figure 55 on page 102](#)).

Figure 55: Connect an ACX7100-48L Router to a Network for Out-of-Band Management

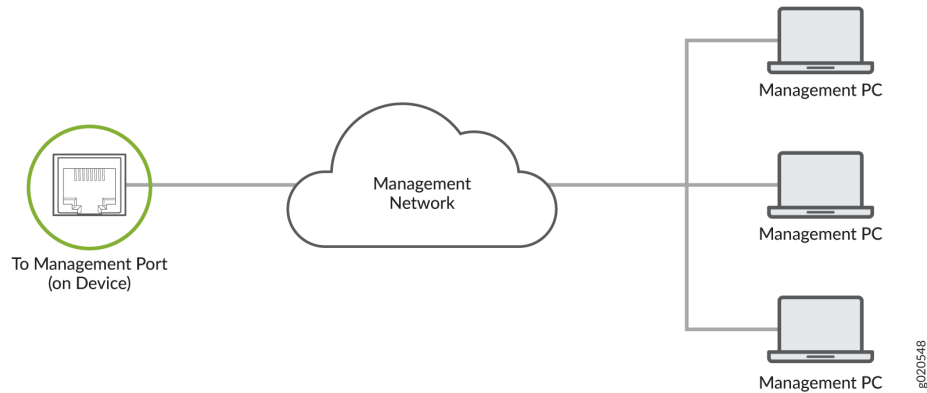

Connect an ACX7100-48L Router to External Clocking and Timing Devices

The ACX7100-48L router has four SMB connector ports that support 1-PPS and 10-MHz timing devices.



NOTE: Ensure that you use a cable of 3 m or less in length for the 10-MHz and 1-PPS connectors.

To connect the SMB to BNC coaxial cable to the external clocking input port:

1. Connect one end of the SMB to BNC coaxial cable to either the 1-PPS connector or the 10-MHz connector on the router.
2. Connect the other end of the SMB to BNC coaxial cable to the 1-PPS or 10-MHz measurement equipment.



NOTE: Ensure that the 10-MHz or 1-PPS source network equipment contains low-voltage complementary metal oxide semiconductor (CMOS) or is compatible with low-voltage (3.3 V) transistor-transistor logic (TTL).

Perform Initial Software Configuration for the ACX7100-48L Routers

Before you begin connecting and configuring an ACX7100-48L router, set the following parameter values on the console server or PC:

- Baud Rate—9600
- Flow Control—None
- Data—8
- Parity—None
- Stop Bits—1
- DCD State—Disregard

You must perform the initial configuration of the ACX7100-48L router through the console port using the command-line interface (CLI).

1. Connect the console port on the ACX7100-48L to a laptop or desktop PC using an RJ-45 cable and RJ-45 to DB-9 adapter. The console (**CON**) port is the lower RJ-45 port on the right side of the port panel.



NOTE: We no longer include the RJ-45 console cable with the DB-9 adapter as part of the device package. If the console cable and adapter are not included in your device package, or if you need a different type of adapter, you can order the following separately:

- RJ-45 to DB-9 adapter (JNP-CBL-RJ45-DB9)
- RJ-45 to DB-9 adapter (JNP-CBL-RJ45-DB9)
- RJ-45 to USB-C adapter (JNP-CBL-RJ45-USBC)

If you want to use RJ-45 to USB-A or RJ-45 to USB-C adapter you must have X64 (64-Bit) Virtual COM port (VCP) driver installed on your PC. See, <https://ftdichip.com/drivers/vcp-drivers/> to download the driver.



NOTE: If your laptop or desktop PC doesn't have a serial port, use a serial-to-USB adapter (not provided).

- At the Junos OS login prompt, type **root** to log in. You don't need to enter a password. If the software boots before you connect your laptop or desktop PC to the console port, you might need to press the Enter key for the prompt to appear.

```
login: root
```

- Start the CLI.

```
root@% cli
```

- Enter configuration mode.

```
root> configure
```

- Stop the chassis auto-upgrade process

```
[edit]  
root@# delete chassis auto-image-upgrade
```

- ZTP is enabled on the ACX7100-48L device in factory default configuration. You must stop ZTP before you proceed to configure any settings.

```
[edit]  
root@# delete system commit factory-settings
```

- Add a password for the root administration user account.

```
[edit]  
root@# set system root-authentication plain-text-password  
New password: password  
Retype new password: password
```

- Commit the configuration.

```
[edit]  
root@# commit
```

9. Wait for the ZTP process to exit. A message appears on the console, confirming that the ZTP process has stopped.

```
[edit]
root@# [ 511.430877] ztp.py[13237]: 2021-03-04 05:28:00 INFO: ZTP:(et-0/2/7) DHCP request
timed out
[ 511.432804] ztp.py[13237]: 2021-03-04 05:28:00 INFO: ZTP: checkZTPAbort: Upgrade
detected pending abort
[ 511.433586] ztp.py[13237]: 2021-03-04 05:28:00 INFO: ZTP: notifier loop user requested
ZTP abort
[ 511.485370] ztp.py[13237]: 2021-03-04 05:28:00 INFO: ZTP: exiting
[ 511.580800] ztp.py[31898]: Notice: PID found for app ztp in /var/run/pid/ztp.pid is
13237.Executing command: (/usr/sbin/cleanzk -c /var/run/zkid/13237.id;rm /var/run/zkid/
13237.id)
[ 512.614206] ztp.py[31898]: rm: cannot remove '/var/run/zkid/13237.id': No such file or
directory
```

10. (Optional) Give the router a name. If the name includes spaces, enclose the name in quotation marks (" ").

```
[edit]
root@# set system host-name host-name
```

11. Configure the default gateway.

```
[edit]
root@# set routing-options static route default next-hop address
```

12. Configure the IP address and prefix length for the management port on the router. On the ACX7100-48L, the management port is the upper RJ-45 port on the right side of the port panel and is labeled **MGMT**.

```
[edit]
root@# set interfaces re0:mgmt-0 unit 0 family inet address address/prefix-length
```

13. (Optional) Configure the static routes to remote prefixes with access to the management port.

```
[edit]
root@# set routing-options static route remote-prefix next-hop destination-ip retain no-
readvertise
```

14. Enable Telnet service, if needed.

```
[edit]
root@# set system services telnet
```



NOTE: When Telnet is enabled, you cannot log in to the ACX7100-48L through Telnet using root credentials. Root login is allowed only for SSH access.

15. Enable SSH service.

```
[edit]
root@# set system services ssh
```

16. To allow users to log in to the router as root through SSH, include the **root-login** statement.

```
[edit system services ssh]
root@# root-login (allow | deny | deny-password)
```



NOTE: By default, users are not allowed to log in to the router as root through SSH.

17. Commit the configuration. Your changes become the active configuration for the router.

```
[edit]
root@# commit
```

5

CHAPTER

Maintaining Components

Maintaining the ACX7100-48L Fan Modules | 108

Maintaining the ACX7100-48L Power Supplies | 111

Maintain the ACX7100-48L Transceivers and Fiber-Optic Cables | 119

Maintaining SATA Solid State Drive in an ACX7100-48L | 129

Uninstall the ACX7100-48L Router | 132

Maintaining the ACX7100-48L Fan Modules

IN THIS SECTION

- [Remove a Fan Module from an ACX7100-48L Router | 108](#)
- [Install a Fan Module in an ACX7100-48L Router | 109](#)

Remove a Fan Module from an ACX7100-48L Router

Before you remove a fan module from an ACX7100-48L router, ensure that you have taken the necessary precautions to prevent electrostatic discharge (ESD) damage (see "[Prevention of Electrostatic Discharge Damage](#)" on page 174).

Ensure that you have the following parts and tools available to remove a fan module from an ACX7100-48L router:

- ESD grounding strap
- Antistatic bag or an antistatic mat
- Phillips (+) screwdriver, number 2

The fan modules in ACX7100-48L routers are hot-removable and hot-insertable field replaceable units (FRUs): you can remove and replace them without powering off the router or disrupting routing functions.



CAUTION: Replace a failed fan module with a new fan module within 1 minute of removal to prevent chassis overheating. Before removing the fan module, ensure that you have a replacement fan module at hand.

To remove a fan module from an ACX7100-48L router (see [Figure 56 on page 109](#)):

1. Place the antistatic bag or the antistatic mat on a flat, stable surface.
2. Wrap and fasten one end of the ESD grounding strap around your bare wrist, and connect the other end of the strap to the ESD point on the chassis.
3. Using a Phillips screwdriver, loosen the locking screw (3 or 4 turns).

4. Grasp the handle on the fan module and pull firmly to slide the fan module halfway out of the chassis.



WARNING: To avoid injury, do not touch the fan with your hands or any tools as you slide the fan module out of the chassis—the fan might still be running.

5. When the fan stops spinning, slide the fan module completely out of the chassis.
6. Place the fan module in the antistatic bag or on the antistatic mat placed on a flat, stable surface.

Figure 56: Remove a Fan Module from an ACX7100-48L Router

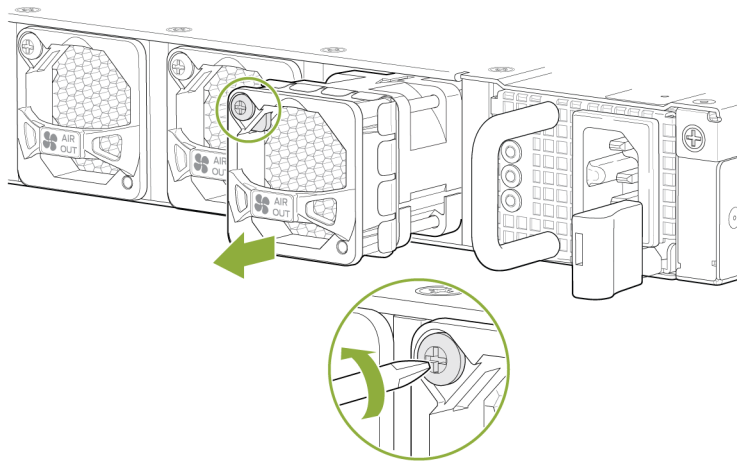

8101167



NOTE: When you remove a fan module, the CLI message **Fan/Blower is Absent** is logged in the system log, and Junos OS raises a major alarm.

Install a Fan Module in an ACX7100-48L Router

Before you install a fan module in an ACX7100-48L router, ensure that you have taken the necessary precautions to prevent electrostatic discharge (ESD) damage (see "[Prevention of Electrostatic Discharge Damage](#)" on page 174).

The fan modules in an ACX7100-48L router are hot-removable and hot-insertable field replaceable units (FRUs): you can remove and replace them without powering off the router or disrupting routing functions.



CAUTION: Replace a failed fan module with a new fan module within 1 minute of removal to prevent chassis overheating. Before removing the fan module, ensure that you have a replacement fan module at hand.



NOTE: The fan module provides port-to-FRU airflow (AO) or FRU-to-port (AI) airflow depending on the product model that you purchase.

Ensure that you have the following parts and tools available to install a fan module in an ACX7100-48L router:

- ESD grounding strap
- Antistatic bag or an antistatic mat
- Phillips (+) screwdriver, number 2

To install a fan module in an ACX7100-48L router (see [Figure 57 on page 111](#)):

1. Wrap and fasten one end of the ESD grounding strap around your bare wrist, and connect the other end of the strap to the ESD point on the chassis.
2. Taking care not to touch the connectors, remove the fan module from its bag.
3. Align the module with the open slot on the rear panel of the chassis and slide it in until it is fully seated.



CAUTION: Damage can occur if you attempt to install a fan module into a chassis with a different airflow direction. Compare the router product model with the airflow marking on the handle to ensure that you are installing a fan module with the same airflow direction as the chassis. The fan modules are designed so that they can only be inserted into the ACX7100-48L product model that supports the same airflow type. See ["Cooling System and Airflow in ACX7100-48L Routers" on page 27](#) for more information.

4. Using a Phillips screwdriver, turn the locking screw until it is tight.

Figure 57: Install a Fan Module in an ACX7100-48L Router

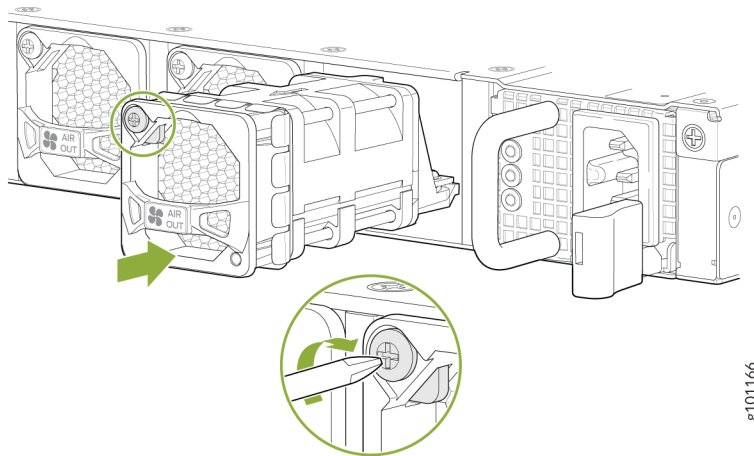

RELATED DOCUMENTATION

[Cooling System and Airflow in ACX7100-48L Routers](#) | 27

Maintaining the ACX7100-48L Power Supplies

IN THIS SECTION

- [Replace an ACX7100-48L AC Power Supply Module](#) | 111
- [Replace an ACX7100-48L DC Power Supply Module](#) | 115

Replace an ACX7100-48L AC Power Supply Module

IN THIS SECTION

- [Remove an AC Power Supply Module from an ACX7100-48L Router](#) | 112

Remove an AC Power Supply Module from an ACX7100-48L Router

Before you remove a PSM from a router, ensure that you have taken the necessary precautions to prevent electrostatic discharge (ESD) damage (see ["Prevention of Electrostatic Discharge Damage"](#) on page 174).

Ensure that you have the following parts and tools available to remove a PSM from a router:

- ESD grounding strap
- Antistatic bag or an antistatic mat

The power supply modules (PSMs) in an ACX7100-48L router are hot-removable and hot-insertable field-replaceable units (FRUs): you can remove and replace them without powering off the router or disrupting routing functions.



CAUTION: Replace the PSM with a new PSM within 1 minute of removal to prevent chassis overheating.

To remove an AC PSM from an ACX7100-48L router (see [Figure 58 on page 113](#)):

1. Place the antistatic bag or the antistatic mat on a flat, stable surface.
2. Wrap and fasten one end of the ESD grounding strap around your bare wrist, and connect the other end of the strap to the ESD point on the chassis.



NOTE: If only one PSM is installed in your router, you must power off the router before removing the PSM. See ["Power Off an ACX7100-48L Router"](#) on page 133.

3. Disconnect power to the router. If the AC power source outlet has a power switch, set it to the off (O) position. If the AC power source outlet does not have a power switch, gently pull out the power cord plug connected to the power source outlet.
4. Remove the power source cable from the power supply faceplate. Remove the power cord from the power supply faceplate by detaching the power cord retainer and gently pulling out the socket end of the power cord connected to the power supply faceplate.
5. Slide the ejector lever toward the handle until you can no longer slide it.
6. Grasp the PSM handle and pull firmly to slide the PSM halfway out of the chassis.

7. Place one hand under the PSM to support it and slide it completely out of the chassis. Take care not to touch power supply components, pins, leads, or solder connections.
8. Place the PSM in the antistatic bag or on the antistatic mat placed on a flat, stable surface.

Figure 58: Remove PSM from an ACX7100-48L Router

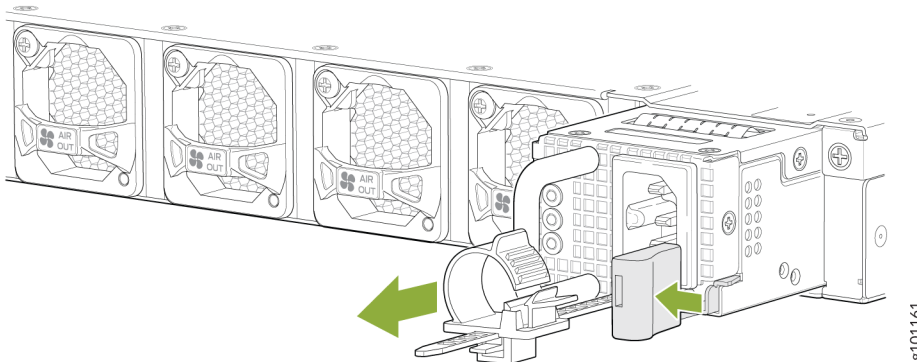

Install an AC Power Supply Module in an ACX7100-48L Router

- Before you install a PSM in a router, ensure that you have taken the necessary precautions to prevent electrostatic discharge (ESD) damage (see ["Prevention of Electrostatic Discharge Damage"](#) on page 174).
- Ensure that the airflow direction of the PSM is the same as that indicated on the chassis. Labels on the PSM handle indicate the direction of airflow. See ["Cooling System and Airflow in ACX7100-48L Routers"](#) on page 27 for more information.

The power supply modules (PSMs) in an ACX7100-48L router are hot-removable and hot-insertable field-replaceable units (FRUs): you can remove and replace them without powering off the router or disrupting routing functions.

To install an AC PSM in an ACX7100-48L router (see [Figure 59 on page 114](#)):

1. Wrap and fasten one end of the ESD grounding strap around your bare wrist, and connect the other end of the strap to the ESD point on the chassis.
2. Taking care not to touch power supply components, pins, leads, or solder connections, remove the PSM from its bag.

CAUTION: Verify that the direction of the arrow on the PSM handle matches the direction of airflow in the chassis. Ensure that each PSM you install in the chassis has the same airflow direction. If you install PSMs with two different airflow directions, Junos OS raises an alarm, and the status (**ALM**) LED blinks amber.

3. Using both hands, place the PSM in the power supply slot on the rear panel of the router and slide it in until it is fully seated and the ejector lever slides into place.
4. Press the latch located on the side of the PSM to slide it into the chassis.
5. Attach the power cord to the PSM.
6. Attach the power cord to the AC power source, and switch on the dedicated customer-site 2-pole circuit breaker. Follow the instructions for your site.
7. Observe the status LED on the power supply faceplate. If the PSM is correctly installed and functioning normally, the status LED lights green steadily.

Figure 59: Install an AC PSM in an ACX7100-48L Router

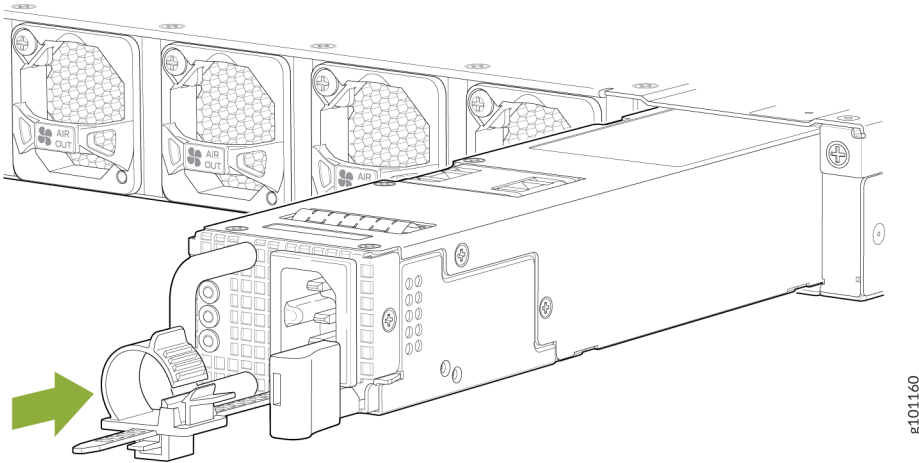

g101160

Figure 60: Install an AC Power Cord in an ACX7100-48L router

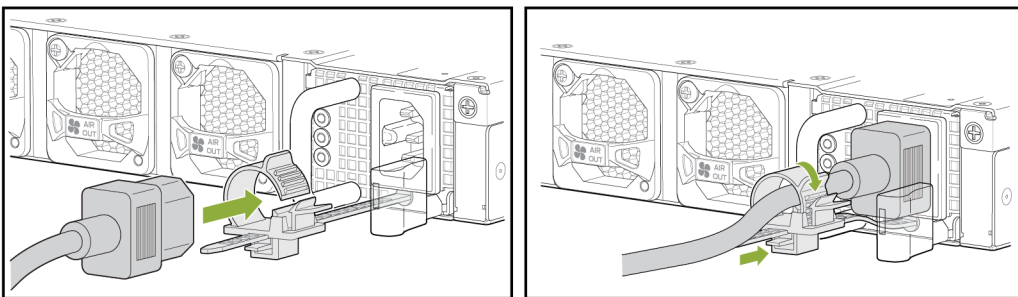

g101188



NOTE: Each PSM must be connected to a dedicated power source outlet.



NOTE: If you have a Juniper J-Care service contract, register any addition, change, or upgrade of hardware components at <https://www.juniper.net/customers/csc/management/updateinstallbase.jsp> . Failure to do so can result in significant delays if you need replacement parts. This note does not apply if you replace components with the same type of component.

Replace an ACX7100-48L DC Power Supply Module

IN THIS SECTION

- [Remove an ACX7100-48L DC Power Supply Module | 115](#)
- [Install an ACX7100-48L DC Power Supply Module | 117](#)

Remove an ACX7100-48L DC Power Supply Module

Before you remove a power supply module (PSM), be aware of the following:



NOTE: The minimum required number of PSMs must always be present in the router.



WARNING: Before performing DC power procedures, ensure that power is removed from the DC circuit. To ensure that all power is off, locate the 2-pole circuit breaker on the panel board that services the DC circuit, switch the circuit breaker to the off position, and tape the switch handle of the circuit breaker in the off position.



CAUTION: To maintain proper cooling and prevent thermal shutdown of the operating power supply unit, each power supply slot must contain a PSM. If you remove a PSM, you must install a replacement PSM shortly after the removal.



NOTE: After powering off a PSM, wait at least 60 seconds before turning it back on.



CAUTION: Do not mix AC and DC PSMs in the same chassis.

To remove a DC PSM:

1. Switch off the dedicated customer-site 2-pole circuit breaker for the PSM being removed. Follow your site's procedures for preventing ESD damage.
2. Make sure that the voltage across the DC power source cable leads is 0 V and that there is no chance that the cables might become active during the removal process.
3. Verify that the status LED on the PSM is not lit.
4. Wrap and fasten one end of the ESD grounding strap around your bare wrist, and connect the other end of the strap to the ESD point on the chassis.
5. Remove the clear plastic cover protecting the terminal studs on the faceplate.
6. Using a socket screw driver, remove the screw from each of the DC power terminals (see [Figure 61 on page 116](#)).
7. Remove the cable lugs from the terminals.
8. Carefully move the power cables out of the way.
9. Press the latch located on the DC PSM, to release it from the chassis.
10. Pull the PSM straight out of the chassis (see [Figure 62 on page 117](#)).

Figure 61: Disconnect the DC Power Cables

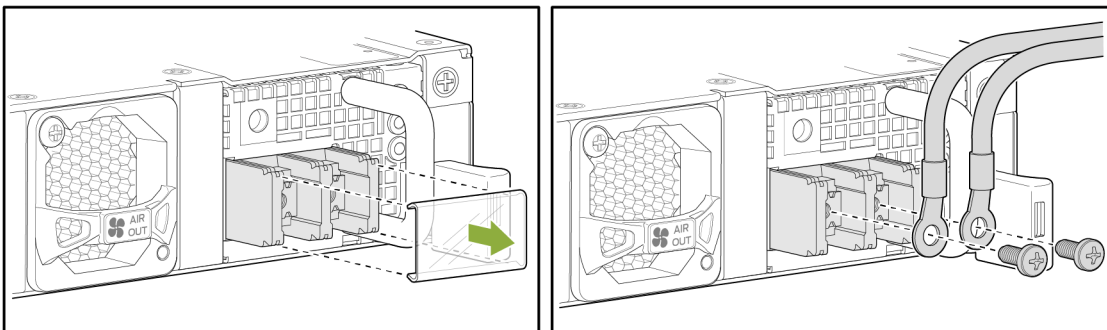
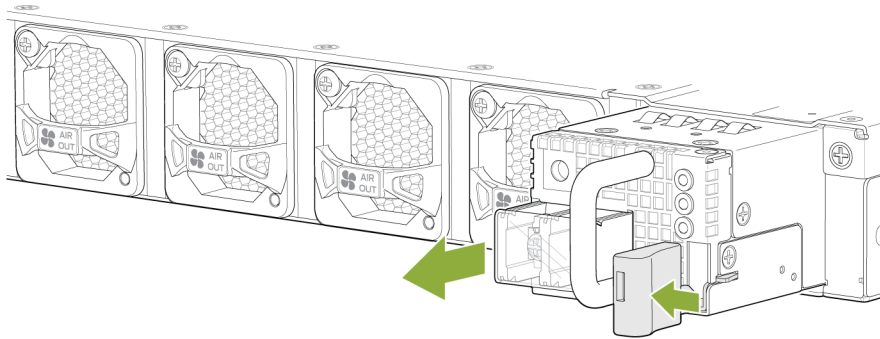

Figure 62: Remove a DC PSM



8101164

Install an ACX7100-48L DC Power Supply Module



WARNING: Before performing DC power procedures, ensure that power is removed from the DC circuit. To ensure that all power is off, locate the circuit breaker on the panel board that services the DC circuit, switch the circuit breaker to the off position, and tape the switch handle of the circuit breaker in the off position.

To install a DC PSM (see [Figure 63 on page 118](#)):

1. Ensure that the voltage across the DC power source cable leads is 0 V and that there is no chance that the cable leads might become active during installation.
2. Wrap and fasten one end of the ESD grounding strap around your bare wrist, and connect the other end of the strap to the ESD point on the chassis.
3. Using both hands, slide the DC PSM straight into the slot on the rear panel of the chassis until the PSM is fully seated in the slot. The PSM faceplate must align with any adjacent PSM faceplate installed in the power supply slot.
4. Remove the clear plastic cover protecting the terminals on the faceplate.
5. Remove the screws from the terminals.
6. Secure each power cable lug to the terminal with the screw (see [Figure 64 on page 119](#)). Do not overtighten the screw.
 - a. Secure the positive (+) DC source power cable lug to the **RTN** (return) terminal.
 - b. Secure the negative (-) DC source power cable lug to the **-48V** (input) terminal.

**CAUTION:**

- You must ensure that power connections maintain the proper polarity. The power source cables might be labeled (+) and (-) to indicate their polarity. There is no standard color coding for DC power cables. The color coding used by the external DC power source at your site determines the color coding for the leads on the power cables that attach to the terminal studs on each PSM.
- Ensure that each power cable lug seats flush against the surface of the terminal block as you are tightening the screws. Ensure that each screw is properly threaded into the terminal. Applying installation torque to the screw when improperly threaded can result in damage to the terminal.

7. Replace the clear plastic cover over the terminals on the faceplate.
8. Verify that the power cabling is correct, that the cables do not touch or block access to router components, and that they do not drape where people could trip over them.
9. Attach the power cable to the DC power source, and switch on the dedicated customer-site 2-pole circuit breaker. Follow the instructions for your site.



NOTE: If more than one PSM is being installed, turn on all PSMs at the same time.

10. Observe the status LED on the power supply faceplate. If the PSM is correctly installed and functioning normally, the status LED lights green steadily.

Figure 63: Install a DC PSM in an ACX7100-48L Router

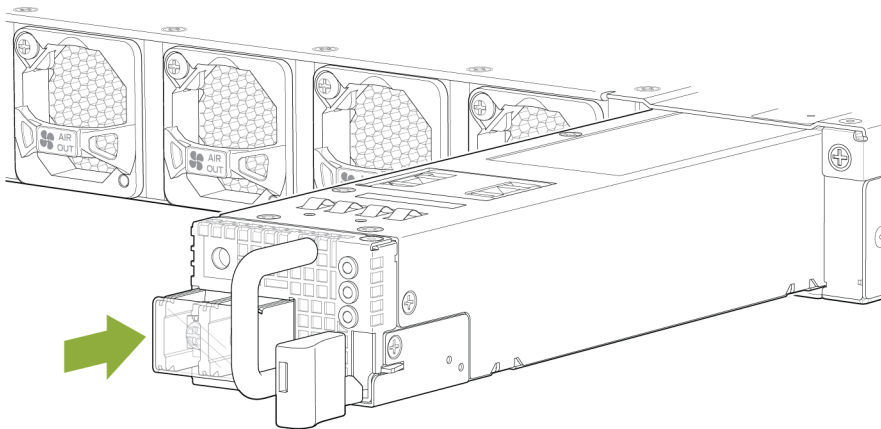

g101163

Figure 64: Connect the DC Power Cables

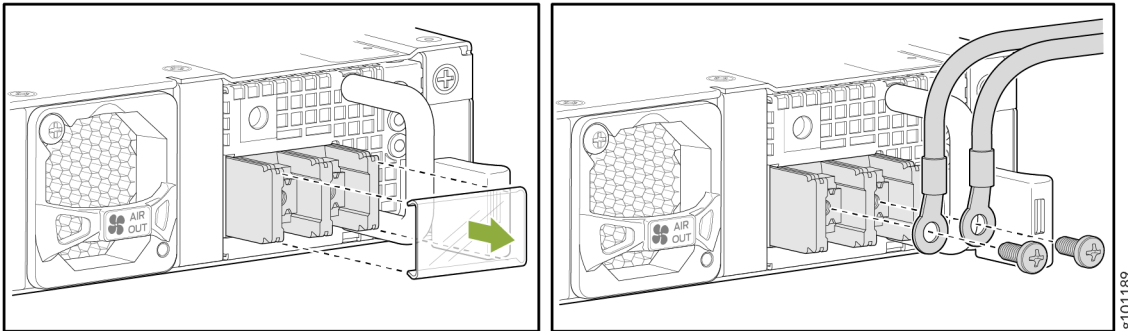

RELATED DOCUMENTATION

| [ACX7100-48L Power System](#) | 32

Maintain the ACX7100-48L Transceivers and Fiber-Optic Cables

IN THIS SECTION

- [Remove a Transceiver](#) | 120
- [Install a Transceiver](#) | 122
- [Remove a QSFP28 Transceiver](#) | 124
- [Install a QSFP28 Transceiver](#) | 126
- [How to Connect a Fiber-Optic Cable from a Transceiver on a ACX7100-48L Router](#) | 127
- [How to Disconnect a Fiber-Optic Cable from a Transceiver on a ACX7100-48L Router](#) | 127
- [How to Maintain Fiber-Optic Cable for an ACX7100-48L Router](#) | 128

The transceivers for the ACX7100-48L router are hot-removable and hot-insertable field-replaceable units (FRUs). You can remove and replace them without powering off the device or disrupting device functions.

To understand how to install or remove a transceiver in a ACX7100-48L router, read the following sections:

Remove a Transceiver

Before you remove a transceiver from a device, ensure that you have taken the necessary precautions for the safe handling of lasers (see "[Laser and LED Safety Guidelines and Warnings](#)" on page 164).

Ensure that you have the following parts and tools available:

- An antistatic bag or an antistatic mat
- Rubber safety caps to cover the transceiver and fiber-optic cable connector
- A dust cover to cover the port or a replacement transceiver

The transceivers for Juniper Networks devices are hot-removable and hot-insertable field-replaceable units (FRUs): You can remove and replace them without powering off the device or disrupting device functions.



NOTE: After you remove a transceiver or when you change the media-type configuration, wait for 6 seconds for the interface to display the operational commands.

[Figure 65 on page 122](#) shows how to remove a QSFP+ transceiver. The procedure is the same for all types of transceivers except for the QSFP28 transceivers.

To remove a transceiver from a device:

1. Place the antistatic bag or antistatic mat on a flat, stable surface.
2. Wrap and fasten one end of the ESD wrist strap around your bare wrist, and connect the other end of the strap to a site ESD point.
3. Label the cable connected to the transceiver so that you can reconnect it correctly.



LASER WARNING: Do not look directly into a fiber-optic transceiver or into the ends of fiber-optic cables. Fiber-optic transceivers and fiber-optic cables connected to transceivers emit laser light that can damage your eyes.



LASER WARNING: Do not leave a fiber-optic transceiver uncovered except when inserting or removing a cable. The rubber safety cap keeps the port clean and prevents accidental exposure to laser light.



CAUTION: Do not bend fiber-optic cables beyond their minimum bend radius. An arc smaller than a few inches in diameter can damage the cables and cause problems that are difficult to diagnose.

4. Remove the cable connected to the transceiver (see *Disconnect a Fiber-Optic Cable*). Cover the transceiver and the end of each fiber-optic cable connector with a rubber safety cap immediately after disconnecting the fiber-optic cables.
5. If there is a cable management system, arrange the cable in the cable management system to prevent it from dislodging or developing stress points. Secure the cable so that it does not support its own weight as it hangs to the floor. Place excess cable out of the way in a neatly coiled loop in the cable management system. Placing fasteners on the loop helps to maintain its shape.



CAUTION: Do not bend the fiber-optic cable beyond its minimum bend radius. An arc smaller than a few inches in diameter can damage the cable and cause problems that are difficult to diagnose.

6. To remove an SFP, SFP+, or a QSFP+ transceiver:
 - a. By using your fingers, pull open the ejector lever on the transceiver to unlock the transceiver.



CAUTION: Before removing the transceiver, make sure that you open the ejector lever completely until you hear it click. This prevents damage to the transceiver.

- b. Grasp the transceiver ejector lever and gently slide the transceiver approximately 0.5 in. (1.3 cm) straight out of the port.



CAUTION: To prevent ESD damage to the transceiver, do not touch the connector pins at the end of the transceiver.

Figure 65: Remove a QSFP+ Transceiver

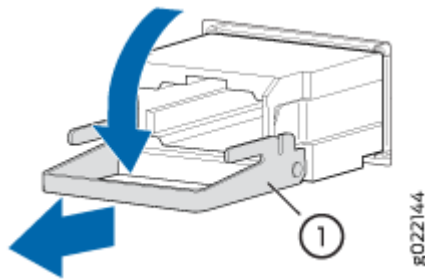

1– Ejector lever

7. By using your fingers, grasp the body of the transceiver and pull it straight out of the port.
8. Place the transceiver in the antistatic bag or on the antistatic mat placed on a flat, stable surface.
9. Place the dust cover over the empty port or install the replacement transceiver.

Install a Transceiver

Before you install a transceiver in a device, ensure that you have taken the necessary precautions for safe handling of lasers (see "[Laser and LED Safety Guidelines and Warnings](#)" on page 164).

Ensure that you have a rubber safety cap available to cover the transceiver.

The transceivers for Juniper Networks devices are hot-removable and hot-insertable field-replaceable units (FRUs): You can remove and replace them without powering off the device or disrupting the device functions.

i **NOTE:** After you insert a transceiver or after you change the media-type configuration, wait for 6 seconds for the interface to display operational commands.

i **NOTE:** We recommend that you use only optical transceivers and optical connectors purchased from Juniper Networks with your Juniper Networks device.

! **CAUTION:** If you face a problem running a Juniper Networks device that uses a third-party optic or cable, the Juniper Networks Technical Assistance Center (JTAC) can help you diagnose the source of the problem. Your JTAC engineer might recommend that you check the third-party optic or cable and potentially replace it with an equivalent Juniper Networks optic or cable that is qualified for the device.

Figure 66 on page 124 shows how to install a QSFP+ transceiver. The procedure is the same for all types of transceivers except the QSFP28 transceivers.

To install a transceiver:



CAUTION: To prevent electrostatic discharge (ESD) damage to the transceiver, do not touch the connector pins at the end of the transceiver.

1. Wrap and fasten one end of the ESD wrist strap around your bare wrist, and connect the other end of the strap to a site ESD point.
2. Remove the transceiver from its bag.
3. Check to see whether the transceiver is covered with a rubber safety cap. If it is not, cover the transceiver with a rubber safety cap.



LASER WARNING: Do not leave a fiber-optic transceiver uncovered except when inserting or removing a cable. The rubber safety cap keeps the port clean and prevents accidental exposure to laser light.

4. If the port in which you want to install the transceiver is covered with a dust cover, remove the dust cover and save it in case you need to cover the port later. If you are hot-swapping a transceiver, wait for at least 10 seconds after removing the transceiver from the port before installing a new transceiver.



CAUTION: Before you slide the transceiver into the port, ensure that the transceiver is aligned correctly. Misalignment might cause the pins to bend, making the transceiver unusable.

5. Using both hands, carefully insert the transceiver in the empty port. The connectors must face the chassis. Slide the transceiver in gently until it is fully seated.
6. Remove the rubber safety cap from the transceiver and the end of the cable, and insert the cable into the transceiver.



LASER WARNING: Do not look directly into a fiber-optic transceiver or into the ends of fiber-optic cables. Fiber-optic transceivers and fiber-optic cable connected to a transceiver emit laser light that can damage your eyes.

CAUTION: Do not leave a fiber-optic transceiver uncovered except when inserting or removing cable. The safety cap keeps the port clean and prevents accidental exposure to laser light.

- If there is a cable management system, arrange the cable in the cable management system to prevent the cable from dislodging or developing stress points. Secure the cable so that it does not support its own weight as it hangs to the floor. Place excess cable out of the way in a neatly coiled loop in the cable management system. Placing fasteners on the loop helps to maintain its shape.

CAUTION: Do not let fiber-optic cable hang free from the connector. Do not allow fastened loops of cable to dangle, which stresses the cable at the fastening point.

CAUTION: Avoid bending fiber-optic cable beyond its minimum bend radius. An arc smaller than a few inches in diameter can damage the cable and cause problems that are difficult to diagnose.

Figure 66: Install a Transceiver

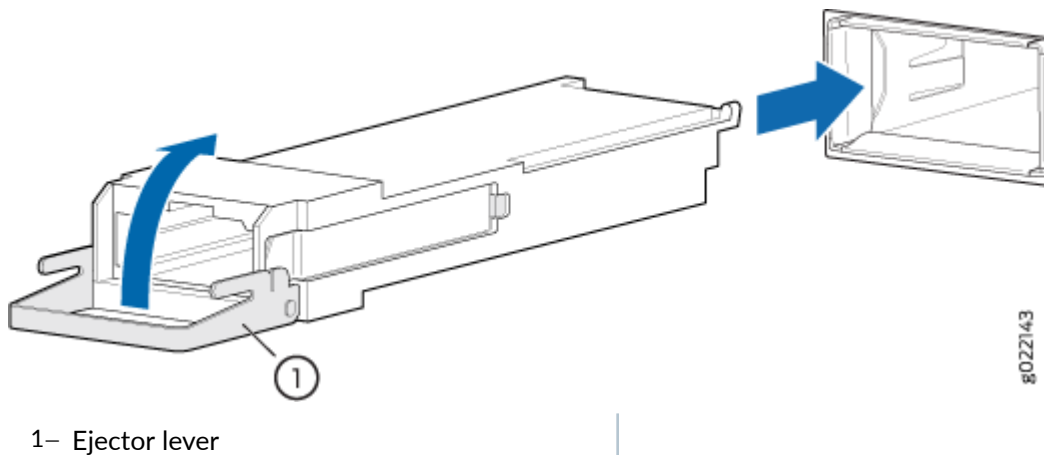

Remove a QSFP28 Transceiver

28-Gbps quad small form-factor pluggable (QSFP28) are transceivers that can be removed from the device. QSFP28 transceivers are hot-insertable and hot-removable. Removing a QSFP28 transceiver does not interrupt the device functioning, but the removed QSFP28 transceiver no longer receives or transmits data.

Figure 67: 28-Gbps Quad Small Form-Factor Pluggable (QSFP28)

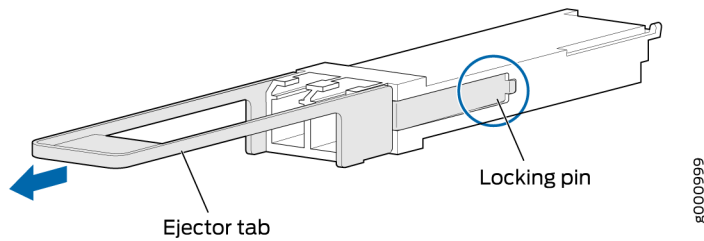

To remove a QSFP28 transceiver (see [Figure 67 on page 125](#)):

1. Place an electrostatic bag or antistatic mat on a flat, stable surface to receive the QSFP28 transceiver. Have ready a rubber safety cap for the QSFP28 transceiver and the cable.
2. Attach an electrostatic discharge (ESD) grounding strap to your bare wrist, and connect the strap to one of the ESD points on the chassis.
3. Label the cable connected to the QSFP28 transceiver so that you can later reconnect it to the correct QSFP28 transceiver.
4. Disconnect the cable from the QSFP28 transceiver. Immediately cover the transceiver and the end of the cable with a rubber safety cap.



LASER WARNING: Do not look directly into a fiber-optic transceiver or into the ends of fiber-optic cables. Fiber-optic transceivers and fiber-optic cable connected to a transceiver emit laser light that can damage your eyes.



CAUTION: Do not leave a fiber-optic transceiver uncovered except when inserting or removing cable. The safety cap keeps the port clean and prevents accidental exposure to laser light.

5. Arrange the cable in the cable management system to prevent it from dislodging or developing stress points. Secure the cable so that it is not supporting its own weight as it hangs to the floor. Place excess cable out of the way in a neatly coiled loop in the cable management system. Placing fasteners on the loop helps to maintain its shape.



CAUTION: Avoid bending fiber-optic cable beyond its minimum bend radius. An arc smaller than a few inches in diameter can damage the cable and cause problems that are difficult to diagnose.

6. Pull the transceiver's rubber handle straight back. The locking pins on the transceiver automatically release. Place the transceiver on the antistatic mat or in the electrostatic bag.

Install a QSFP28 Transceiver

To install a replacement QSFP28:

1. Attach an electrostatic discharge (ESD) grounding strap to your bare wrist, and connect the strap to one of the ESD points on the chassis.
2. Verify that a rubber safety cap covers the QSFP28 transceiver, installing one if necessary.
3. Orient the QSFP28 over the port so that the QSFP28 connector faces the appropriate direction.
4. Slide the QSFP28 into the slot until the locking pins lock in place. If there is resistance, remove the QSFP28 and flip it so that the connector faces the other direction.
5. Remove the rubber safety cap from the transceiver and the end of the cable, and insert the cable into the transceiver.



LASER WARNING: Do not look directly into a fiber-optic transceiver or into the ends of fiber-optic cables. Fiber-optic transceivers and fiber-optic cable connected to a transceiver emit laser light that can damage your eyes.



CAUTION: Do not leave a fiber-optic transceiver uncovered except when inserting or removing cable. The safety cap keeps the port clean and prevents accidental exposure to laser light.

6. Arrange the cable in the cable management system to prevent the cable from dislodging or developing stress points. Secure the cable so that it is not supporting its own weight as it hangs to the floor. Place excess cable out of the way in a neatly coiled loop in the cable management system. Placing fasteners on the loop helps to maintain its shape.



CAUTION: Do not let fiber-optic cable hang free from the connector. Do not allow fastened loops of cable to dangle, which stresses the cable at the fastening point.



CAUTION: Avoid bending fiber-optic cable beyond its minimum bend radius. An arc smaller than a few inches in diameter can damage the cable and cause problems that are difficult to diagnose.

7. Verify that the status LEDs on the indicate that the QSFP28 is functioning correctly.

How to Connect a Fiber-Optic Cable from a Transceiver on a ACX7100-48L Router

Before you connect a fiber-optic cable to an optical transceiver installed in the ACX7100-48L router, ensure that you have taken the necessary precautions for safe handling of lasers (see "[Laser and LED Safety Guidelines and Warnings](#)" on page 164).

To connect a fiber-optic cable to an optical transceiver installed in the ACX7100-48L router:



LASER WARNING: Do not look directly into a fiber-optic transceiver or into the ends of fiber-optic cables. Fiber-optic transceivers and fiber-optic cables connected to transceivers emit laser light that can damage your eyes.



LASER WARNING: Do not stare into the laser beam or view it directly with optical instruments even if the interface has been disabled.

1. If the fiber-optic cable connector is covered by a rubber safety cap, remove the cap. Save the cap.
2. If the optical transceiver is covered by a rubber safety cap, remove the cap. Save the cap.
3. Insert the cable connector into the optical transceiver.
4. Secure the cables so that they are not supporting their own weight. Place excess cable out of the way in a neatly coiled loop. Placing fasteners on a loop helps cables maintain their shape.



CAUTION: Do not bend fiber-optic cables beyond their minimum bend radius. Bending the cables beyond their minimum bend radius can damage the cables and cause problems that are difficult to diagnose.



CAUTION: Do not let fiber-optic cables hang free from the connector. Do not allow fastened loops of cables to dangle, which stresses the cables at the fastening point.

How to Disconnect a Fiber-Optic Cable from a Transceiver on a ACX7100-48L Router

Before you disconnect a fiber-optic cable from an optical transceiver installed in a ACX7100-48L router, ensure that you have taken the necessary precautions for safe handling of lasers (see "[Laser and LED Safety Guidelines and Warnings](#)" on page 164).

Ensure that you have the following parts and tools available:

- Rubber safety cap to cover the transceiver
- Rubber safety cap to cover the fiber-optic cable connector

To disconnect a fiber-optic cable from an optical transceiver installed in the ACX7100-48L router:

1. (Recommended) Disable the port in which the transceiver is installed by including the disable statement at the [edit interfaces] hierarchy level for the specific interface.



LASER WARNING: Do not look directly into a fiber-optic transceiver or into the ends of fiber-optic cables. Fiber-optic transceivers and fiber-optic cables connected to transceivers emit laser light that can damage your eyes.



LASER WARNING: Do not stare into the laser beam or view it directly with optical instruments even if the interface has been disabled.

2. Carefully unplug the fiber-optic cable connector from the transceiver.
3. Cover the transceiver with a rubber safety cap.



LASER WARNING: Do not leave a fiber-optic transceiver uncovered except when inserting or removing a cable. The rubber safety cap keeps the port clean and prevents accidental exposure to laser light.

4. Cover the fiber-optic cable connector with the rubber safety cap.

How to Maintain Fiber-Optic Cable for an ACX7100-48L Router

To maintain fiber-optic cables in a ACX7100-48L router:

- When you unplug a fiber-optic cable from a transceiver, place rubber safety caps over the transceiver and on the end of the cable.
- Anchor fiber-optic cable to avoid stress on the connectors. When attaching a fiber-optic cable to a transceiver, be sure to secure the fiber-optic cable so that it does not support its own weight as it hangs to the floor. Never let a fiber-optic cable hang free from the connector.
- Do not bend fiber-optic cables beyond their minimum bend radius. Bending the cables beyond their minimum bend radius can damage the cables and cause problems that are difficult to diagnose.

- Frequent plugging and unplugging of fiber-optic cables in and out of optical instruments can damage the instruments, which are expensive to repair. Attach a short fiber extension to the optical equipment. Any wear and tear due to frequent plugging and unplugging is then absorbed by the short fiber extension, which is easier and less expensive to replace than the instruments.
- Keep fiber-optic cable connections clean. Microdeposits of oil and dust in the canal of the transceiver or cable connector can cause loss of light, reduction in signal power, and possibly intermittent problems with the optical connection.

To clean the transceiver canal, use an appropriate fiber-cleaning device such as RIFOCS Fiber Optic Adaptor Cleaning Wands (part number 946). Follow the directions in the cleaning kit you use.

After cleaning the transceiver, make sure that the connector tip of the fiber-optic cable is clean. Use only an approved alcohol-free fiber-optic cable cleaning kit such as the Cletop-S® Fiber Cleaner. Follow the directions in the cleaning kit you use.

Maintaining SATA Solid State Drive in an ACX7100-48L

IN THIS SECTION

- [Removing a SATA Solid State Drive from an ACX7100-48L | 129](#)
- [Installing a SATA Solid State Drive in an ACX7100-48L | 131](#)

Removing a SATA Solid State Drive from an ACX7100-48L

Before you remove an SATA SSD from the device, ensure that you have taken the necessary precautions to prevent electrostatic discharge (ESD) damage (see "[Prevention of Electrostatic Discharge Damage](#)" on [page 174](#)).

Ensure that you have the following parts and tools available to remove a SATA SSD from an ACX7100-48L router:

- ESD grounding strap
- Antistatic bag or an antistatic mat

- Phillips (+) screwdriver, number 1

The ACX7100-48L supports two 100 GB Serial Advanced Technology Attachment (SATA) solid state drives (SSD). The SSDs cannot be installed or removed when the system is up. You must shutdown the system before replacing the SSD. The SSDs are preinstalled in the ACX7100-48L.

1. Place the antistatic bag or the antistatic mat on a flat, stable surface.
2. Wrap and fasten one end of the ESD grounding strap around your bare wrist, and connect the other end of the strap to the ESD point on the chassis.
3. Remove the three captive screws securing the SSD cover plate by using the Phillips (+) screwdriver. The SSD cover plate is located under the chassis (see [Figure 70 on page 131](#)).

Figure 68: Removing the SATA SSD Cover Plate

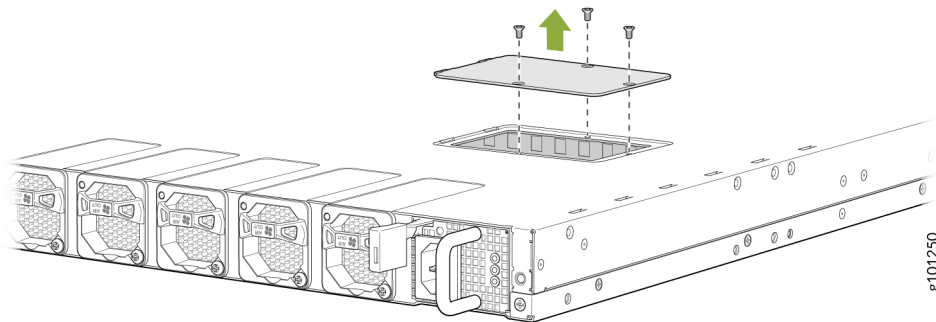

4. Remove the single screw holding the SATA SSD in place and slide the drive out of the plug (see [Figure 69 on page 130](#) and [Figure 70 on page 131](#)).

Figure 69: SATA SSDs

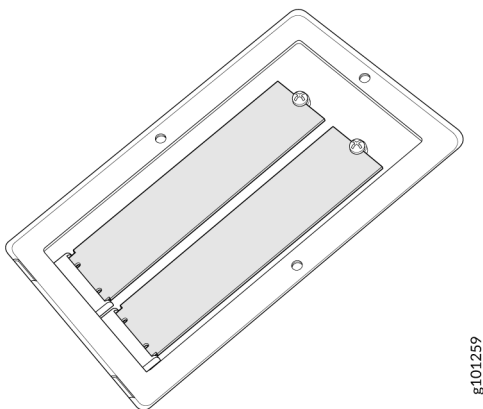
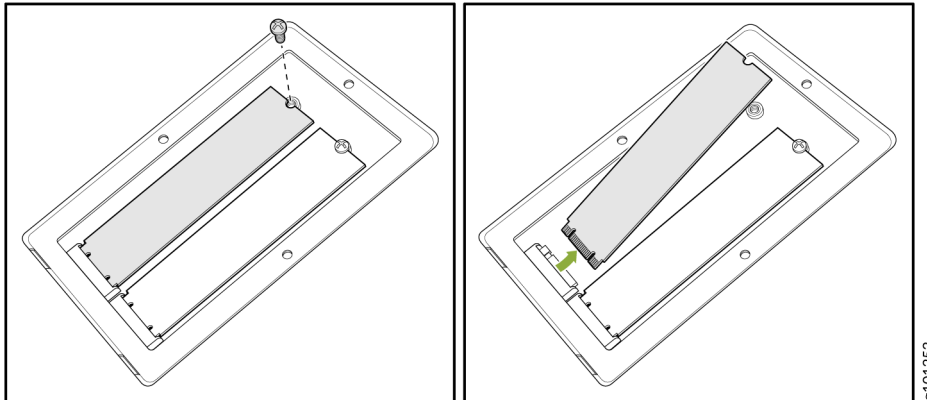

Figure 70: Removing the SATA SSD



5. Place the SATA SSD in an electrostatic bag or on an antistatic mat.
6. Place the SSD cover plate back on the chassis and tighten the three captive screws securing the SSD cover plate.

Installing a SATA Solid State Drive in an ACX7100-48L

Before you install an SATA SSD in the device, ensure that you have taken the necessary precautions to prevent electrostatic discharge (ESD) damage (see ["Prevention of Electrostatic Discharge Damage" on page 174](#)).

Ensure that you have the following parts and tools available to install an SATA SSD in the ACX7100-48L router:

- ESD grounding strap
- Antistatic bag or an antistatic mat
- Phillips (+) screwdriver, number 1

1. Place the antistatic bag or the antistatic mat on a flat, stable surface.
2. Wrap and fasten one end of the ESD grounding strap around your bare wrist, and connect the other end of the strap to the ESD point on the chassis.
3. If not already removed, remove the three captive screws securing the SSD cover plate by using the Phillips (+) screwdriver. The SSD cover plate is located under the chassis (see [Figure 71 on page 132](#)).

Figure 71: Removing the SATA SSD Cover Plate

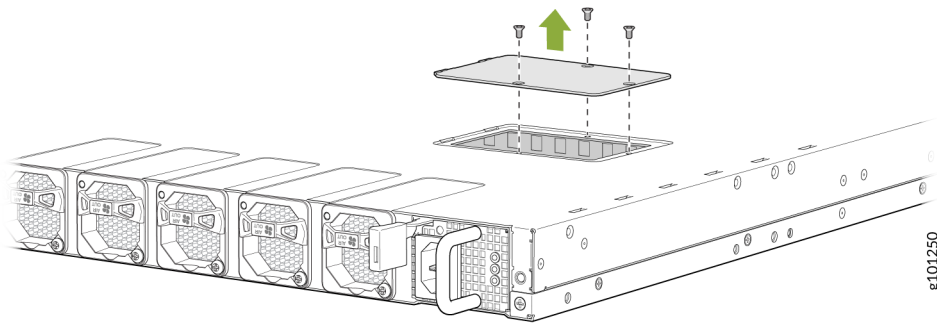

- Slide the drive into the SSD plug and tighten the single screw holding the SATA SSD (see [Figure 72](#) on page 132).

Figure 72: Installing the SATA SSD

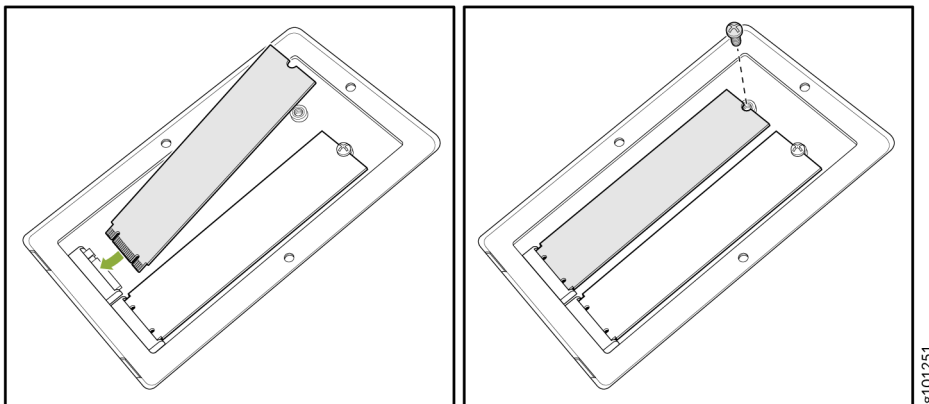

- Place the SSD cover plate back on the chassis and tighten the three captive screws securing the SSD cover plate.

Uninstall the ACX7100-48L Router

IN THIS SECTION

- [Power Off an ACX7100-48L Router](#) | 133

- [Remove an ACX7100-48L Router from a Rack or Cabinet](#) | 134

Power Off an ACX7100-48L Router

Before you power off an ACX7100-48L router:

- Ensure that you have taken the necessary precautions to prevent electrostatic discharge (ESD) damage. See "[Prevention of Electrostatic Discharge Damage](#)" on page 174.
- Ensure that you do not need to forward traffic through the router.

Ensure that you have the following parts and tools available to power off the router:

- An ESD grounding strap
- An external management device such as a PC
- An RJ-45 to DB-9 rollover cable to connect the external management device to the console port
- A Phillips number 2 screwdriver

To power off your ACX7100-48L router:

1. Connect to the router using one of the following methods:
 - Connect a management device to the console (**CON**) port on the router. For instructions about connecting a management device to the console (**CON**) port, see "[Connect an ACX7100-48L Router to a Management Console](#)" on page 99.
 - You can shut down the router from a management device on your out-of-band management network. For instructions about connecting a management device to the management (**MGMT**) port, see "[Connect an ACX7100-48L Router to a Network for Out-of-Band Management](#)" on page 101.
2. Shut down Junos OS from the external management device by issuing the request `system halt` operational mode CLI command. This command shuts down the router gracefully and preserves system state information. A message appears on the console, confirming that the operating system has halted.

```
user@host> request system halt
All nodes will halt, do you wish to continue ? [yes,no] (no) yes
```

You see the following output (or something similar, depending on the hardware being shut down) after entering the command:

```
System going down IMMEDIATELY

*** System shutdown message from user@host ***

halt the system at Tue Feb 16 16:40:55 2021
```

3. Wrap and fasten one end of the ESD grounding strap around your bare wrist, and connect the other end of the strap to the ESD point on the chassis.
4. Disconnect power to the router by performing one of the following tasks:
 - AC power supply—If the AC power source outlet has a power switch, set it to the off (O) position. If the AC power source outlet does not have a power switch, gently pull out the power cord plug connected to the power source outlet.
 - DC power supply—Switch the circuit breaker on the panel board that services the DC circuit to the off position.
5. Remove the power source cable from the power supply faceplate:
 - AC power supply—Remove the power cord from the power supply faceplate by detaching the power cord retainer and gently pulling out the socket end of the power cord connected to the power supply faceplate.
 - DC power supply—Remove the screws securing the ring lugs attached to the power source cables to the power supply module (PSM) using the screwdriver, and remove the power source cables from the PSM. Replace the screws on the terminals and tighten them.
6. Uncable the router before removing it from the rack or cabinet.

Remove an ACX7100-48L Router from a Rack or Cabinet

Before removing your ACX7100-48L router from its rack:

Ensure that you have the following parts and tools available:

- A Phillips (+) screwdriver, number 2 or number 3, depending on the size of your rack mounting screws.

If you need to relocate an installed ACX7100-48L router, use the procedure described in this topic.



NOTE: When you remove multiple devices from a rack, remove the device in the top of the rack first and proceed to remove the rest of the devices from top to bottom.

- Ensure that the rack is stable and secured to the building.
- Ensure that there is enough space to place the removed router in its new location and along the path to the new location.
- Read "[General Safety Guidelines and Warnings](#)" on page 150.
- Use the appropriate power-off sequence to safely power off the device. See "[Power Off an ACX7100-48L Router](#)" on page 133.
- Disconnect the power cords.
- Ensure that you have disconnected any cables or wires attached to the router ports.

To remove an ACX7100-48L router from a rack or cabinet:

1. Have one person support the weight of the router while another person uses the screwdriver to remove the front mounting screws that attach the chassis mounting rails to the rack or cabinet.
2. Slowly slide the router out of the rack, with the mounting rails attached to its sides.
3. Use the screwdriver to remove the mounting screws that attach the mounting blades attached to the rear of the rack or cabinet.
4. Place the removed screws and mounting blades in a labeled bag. You will need them when you reinstall the chassis.
5. Transport the router to your new location.

RELATED DOCUMENTATION

| [Unpack and Mount an ACX7100-48L Router](#) | 72

6

CHAPTER

Troubleshooting Hardware

[Troubleshooting the ACX7100-48L Router | 137](#)

Troubleshooting the ACX7100-48L Router

IN THIS SECTION

- [Alarm Types and Severity Classes on ACX Series Routers | 137](#)

Alarm Types and Severity Classes on ACX Series Routers

IN THIS SECTION

- [Alarm Types | 138](#)
- [Alarm Severity Classes | 138](#)

Before monitoring the alarms on the router, become familiar with the terms defined in [Table 33 on page 137](#).

Table 33: Alarm Terms

Term	Definition
Alarm	Signal that alerts you to conditions that might prevent normal operation. On a router, the alarm signal is the ALM LED that is lit on the front of the chassis.
Alarm condition	Failure event that triggers an alarm.
Alarm severity	Seriousness of the alarm. The level of severity can be either major (steady red) or minor (steady amber).
Chassis alarm	Predefined alarm that is triggered by a physical condition on the router, such as a power failure, excessive component temperature, or media failure.

Table 33: Alarm Terms (Continued)

Term	Definition
System alarm	Predefined alarm that is triggered by a missing rescue configuration or failure to install a license for a licensed software feature.

Alarm Types

The router supports these alarms:

- Chassis alarms indicate a failure on the router or one of its components. Chassis alarms are preset and cannot be modified.
- System alarms indicate a missing rescue configuration. System alarms are preset and cannot be modified, although you can configure them to appear automatically in the J-Web interface display or CLI display.

Alarm Severity Classes

Alarms on ACX Series routers have two severity classes:

- Major (steady red)—Indicates a critical situation on the router that has resulted from one of the following conditions. A major alarm condition requires immediate action.
 - One or more hardware components have failed.
 - One or more hardware components have exceeded temperature thresholds.
 - An alarm condition that is configured on an interface has triggered a critical warning.
- Minor (steady amber)—Indicates a noncritical condition on the router that, if left unchecked, might cause an interruption in service or degradation in performance. A minor alarm condition requires monitoring or maintenance.

A missing rescue configuration generates a minor system alarm.

RELATED DOCUMENTATION

| [Contacting Customer Support and Returning the Chassis or Components](#) | 140

7

CHAPTER

Contacting Customer Support and Returning the Chassis or Components

Contacting Customer Support and Returning the Chassis or Components | 140

Contacting Customer Support and Returning the Chassis or Components

IN THIS SECTION

- [How to Return a Hardware Component to Juniper Networks, Inc. | 140](#)
- [How to Locate the Serial Number on an ACX7100-48L Router or Component | 141](#)
- [Contact Customer Support to Obtain Return Material Authorization | 146](#)
- [Guidelines for Packing Hardware Components for Shipment | 146](#)

How to Return a Hardware Component to Juniper Networks, Inc.

If a hardware component fails, please contact Juniper Networks, Inc. to obtain a Return Material Authorization (RMA) number. This number is used to track the returned material at the factory and to return repaired or new components to the customer as needed.



NOTE: Do not return any component to Juniper Networks, Inc. unless you have first obtained an RMA number. Juniper Networks, Inc. reserves the right to refuse shipments that do not have an RMA. Refused shipments are returned to the customer by collect freight.

For more information about return and repair policies, see the customer support webpage at <https://support.juniper.net/support/>.

For product problems or technical support issues, contact the Juniper Networks Technical Assistance Center (JTAC) by using the Service Request Manager link at <https://support.juniper.net/support/> or at 1-888-314-JTAC (within the United States) or 1-408-745-9500 (from outside the United States).

To return a defective hardware component:

1. Determine the part number and serial number of the defective component.
2. Obtain an RMA number from the Juniper Networks Technical Assistance Center (JTAC). You can send e-mail or telephone as described above.
3. Provide the following information in your e-mail message or during the telephone call:
 - Part number and serial number of component

- Your name, organization name, telephone number, and fax number
 - Description of the failure
4. The support representative validates your request and issues an RMA number for return of the component.
 5. Pack the component for shipment.

How to Locate the Serial Number on an ACX7100-48L Router or Component

IN THIS SECTION

- [List the Chassis and Component Details Using the CLI | 141](#)
- [Locate the Chassis Serial Number ID Label on an ACX7100-48L Router | 143](#)
- [Locate the Serial Number ID Labels on ACX7100-48L Power Supply Modules | 144](#)
- [Locate the Serial Number ID Label on an ACX7100-48L Fan Module | 145](#)

If you are returning a router or component to Juniper Networks for repair or replacement, you must locate the serial number of the router or component. You must provide the serial number to the Juniper Networks Technical Assistance Center (JTAC) when you contact them to obtain a Return Materials Authorization (RMA). See *Contact Customer Support*.

If the router is operational and you can access the command-line interface (CLI), you can list serial numbers for the router and for some components with a CLI command. If you do not have access to the CLI or if the serial number for the component does not appear in the command output, you can locate the serial number ID label on the router or component.



NOTE: If you want to find the serial number ID label on a component, you need to remove the component from the router chassis, for which you must have the required parts and tools available.

List the Chassis and Component Details Using the CLI

To list the components and serial numbers of ACX7100-48L routers, use the `show chassis hardware` CLI operational mode command.

The show chassis hardware output for ACX7100-48L:

```

user@device> show chassis hardware
Hardware inventory:
Item          Version  Part number  Serial number  Description
Chassis                               YW0220320039  JNP7100-48L [ACX7100-48L]
PSM 1        REV 04   740-085431  1ED79520221   JPSU-1600W-AC-AFO
Routing Engine 0 REV 04   611-112446  YY0220320013  RE-JNP-7100
CB 0         REV 05   650-113149  YW0220320039  Control Board
FPC 0
  BUILTIN    BUILTIN    BUILTIN      ACX7100-48L
  PIC 0
    BUILTIN    BUILTIN    BUILTIN      MRATE- 48xSFP56 + 6xQSFP56-DD
    Xcvr 0    REV 01   740-068639  1A1M31A311008 SFP28-25G-BASE-SR
    Xcvr 1    REV 01   740-030658  AA1230AZYWW   SFP+-10G-USR
    Xcvr 2    REV 01   740-031980  AP42G0C       SFP+-10G-SR
    Xcvr 3    REV 01   740-031980  ARN2FS9       SFP+-10G-SR
    Xcvr 4    REV 01   740-031980  AP4150P       SFP+-10G-SR
    Xcvr 5    REV 01   740-031980  123363A01134 SFP+-10G-SR
    Xcvr 6    REV 01   740-031980  B11E02539    SFP+-10G-SR
    Xcvr 7    REV 01   740-031980  ARQ0WRX       SFP+-10G-SR
    Xcvr 12   REV 01   740-031980  193363A00707 SFP+-10G-SR
    Xcvr 15   REV 01   740-031980  AMS15RT       SFP+-10G-SR
    Xcvr 18   REV 01   740-068639  1A1M31A5370MX SFP28-25G-BASE-SR
    Xcvr 19   REV 01   740-068639  1A1M31A5370MS SFP28-25G-BASE-SR
    Xcvr 21   REV 01   740-068639  1A1M31A5370MW SFP28-25G-BASE-SR
    Xcvr 22   REV 01   740-068639  1A1M31A5370MT SFP28-25G-BASE-SR
    Xcvr 43   REV 01   740-031980  CH09KN1H4    SFP+-10G-SR
    Xcvr 44   REV 01   740-031980  AMB0TC1      SFP+-10G-SR
    Xcvr 46   REV 01   740-031980  AP40WQN      SFP+-10G-SR
    Xcvr 47   REV 01   740-031980  APR1BCS      SFP+-10G-SR
    Xcvr 48   REV 01   740-054053  XXH0KH1      QSFP+-4X10G-SR
    Xcvr 49   REV 01   740-058734  1ECQ144605L  QSFP-100GBASE-SR4
    Xcvr 50   REV 01   740-054053  XWP0Q7D      QSFP+-4X10G-SR
    Xcvr 51   REV 01   740-058734  1ECQ144604H  QSFP-100GBASE-SR4
    Xcvr 52   REV 01   740-054053  XXH0KGC      QSFP+-4X10G-SR
    Xcvr 53   REV 01   740-058734  1ECQ144605K  QSFP-100GBASE-SR4
Fan Tray 0
- AFO
Fan Tray 1
- AFO
Fan Tray 2
- AFO
Fan Tray 3
- AFO

```

- AFO	
Fan Tray 4	JNP7100 Fan Tray, Front to Back Airflow
- AFO	
Fan Tray 5	JNP7100 Fan Tray, Front to Back Airflow
- AFO	



NOTE: You must remove the fan module to read the fan serial number from the serial number ID label. The fan module serial number cannot be viewed through the CLI. **Fan Tray 2** refers to the third module from the left, counting from 0.

Locate the Chassis Serial Number ID Label on an ACX7100-48L Router

On the ACX7100-48L router product models, the serial number ID label is located on top of the device and in a pull-out tab under the chassis status LEDs. See [Figure 73 on page 143](#) and [Figure 74 on page 144](#) for an example of where to find the serial number ID.

Figure 73: Location of the Serial Number ID Label on an ACX7100-48L router

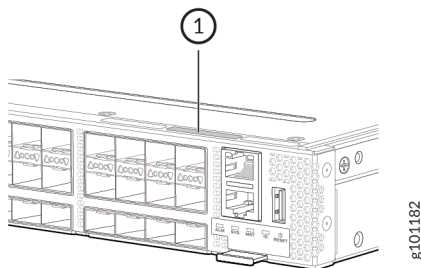
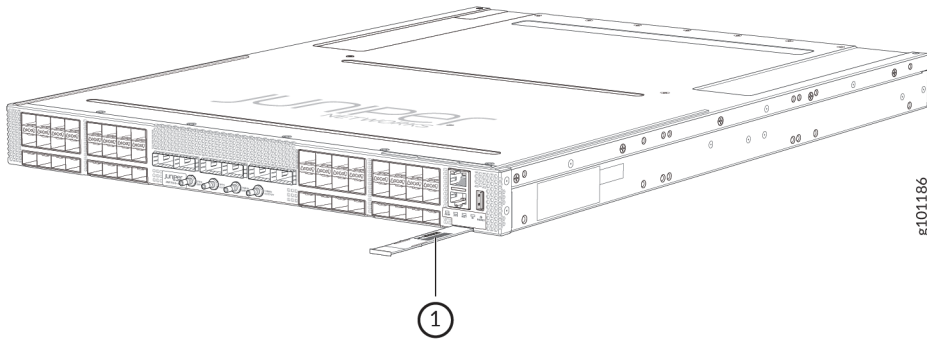

Figure 74: Location of the Serial Number ID Label on an ACX7100-48L router pull-out tab



Locate the Serial Number ID Labels on ACX7100-48L Power Supply Modules

The power supply modules (PSMs) installed in an ACX7100-48L are field-replaceable units (FRUs). For each FRU, you must remove the FRU from the router chassis to see the FRU serial number ID label.

- AC PSM—The serial number ID label is on the top of the AC PSM. See [Figure 75 on page 144](#).

Figure 75: ACX7100-48L AC PSM Serial Number Location

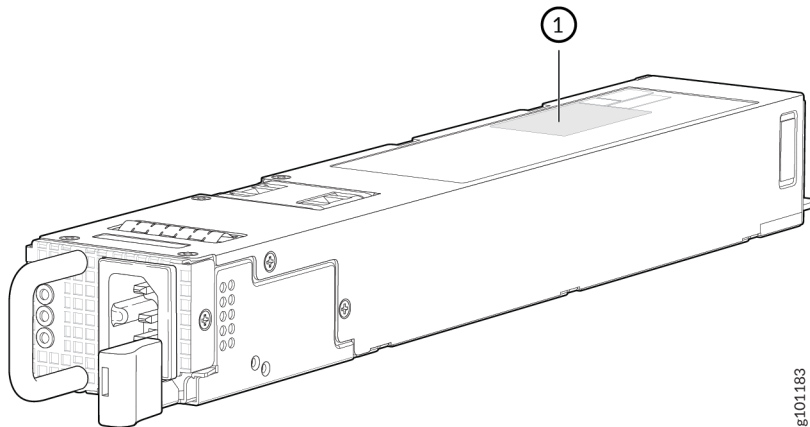

- DC PSM—The serial number ID label is on the top of the DC PSM. See [Figure 76 on page 145](#).

Figure 76: ACX7100-48L DC PSM Serial Number Location

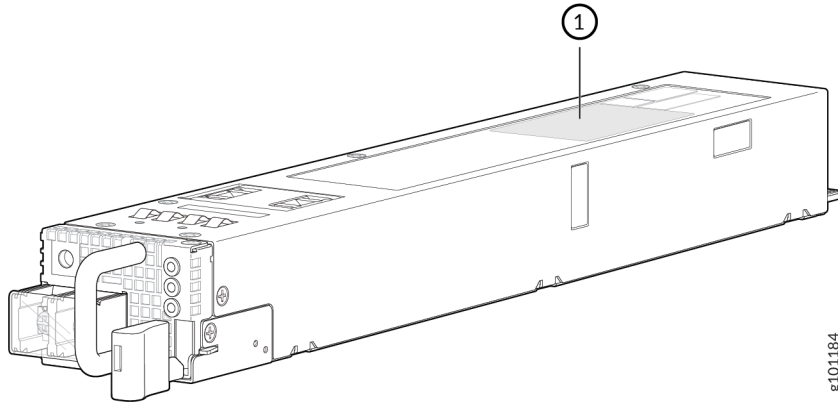

Locate the Serial Number ID Label on an ACX7100-48L Fan Module

The fan modules installed in an ACX7100-48L are field-replaceable units (FRUs). For each FRU, you must remove the FRU from the router chassis to see the FRU serial number ID label.

Fan module—The serial number ID label is on the bottom of the fan module. See [Figure 77 on page 145](#).

Figure 77: ACX7100-48L Fan Module Serial Number Location

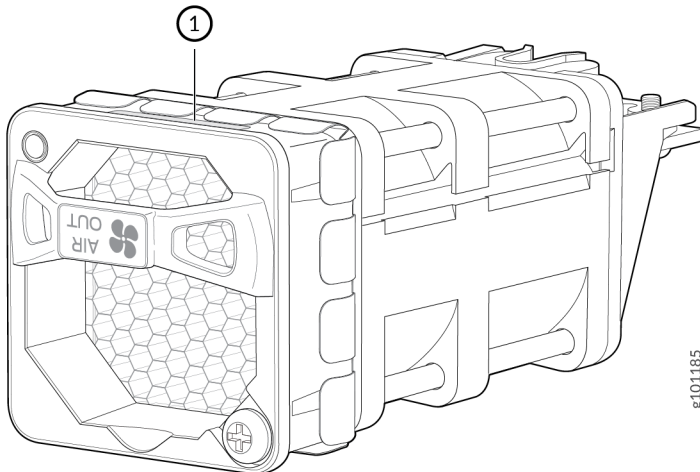

Contact Customer Support to Obtain Return Material Authorization

If you are returning a device or hardware component to Juniper Networks for repair or replacement, obtain a Return Material Authorization (RMA) number from Juniper Networks Technical Assistance Center (JTAC).

After locating the serial number of the device or hardware component you want to return, open a service request with Juniper Networks Technical Assistance Center (JTAC) on the Web or by telephone.

Before you request an RMA number from JTAC, be prepared to provide the following information:

- Your existing service request number, if you have one
- Serial number of the component
- Your name, organization name, telephone number, fax number, and shipping address
- Details of the failure or problem
- Type of activity being performed on the device when the problem occurred
- Configuration data displayed by one or more `show` commands

You can contact JTAC 24 hours a day, seven days a week on the Web or by telephone:

- Service Request Manager: <https://support.juniper.net/support>
- Telephone: +1-888-314-JTAC (+1-888-314-5822), toll free in U.S., Canada, and Mexico



NOTE: For international or direct-dial options in countries without toll free numbers, see <https://support.juniper.net/support>

If you are contacting JTAC by telephone, enter your 12-digit service request number followed by the pound (#) key for an existing case, or press the star (*) key to be routed to the next available support engineer.

The support representative validates your request and issues an RMA number for return of the component.

Guidelines for Packing Hardware Components for Shipment

To pack and ship individual components:

- When you return components, make sure that they are adequately protected with packing materials and packed so that the pieces are prevented from moving around inside the carton.
- Use the original shipping materials if they are available.
- Place individual components in antistatic bags.
- Write the RMA number on the exterior of the box to ensure proper tracking.



CAUTION: Do not stack any of the hardware components.



CHAPTER

Safety and Compliance Information

General Safety Guidelines and Warnings | 150

Definitions of Safety Warning Levels | 151

Qualified Personnel Warning | 153

Warning Statement for Norway and Sweden | 153

Fire Safety Requirements | 154

Installation Instructions Warning | 155

Chassis and Component Lifting Guidelines | 156

Restricted Access Warning | 156

Ramp Warning | 158

Rack-Mounting and Cabinet-Mounting Warnings | 158

Grounded Equipment Warning | 162

Radiation from Open Port Apertures Warning | 163

Laser and LED Safety Guidelines and Warnings | 164

Maintenance and Operational Safety Guidelines and Warnings | 167

General Electrical Safety Guidelines and Warnings | 173

Prevention of Electrostatic Discharge Damage | 174

Site Electrical Wiring Guidelines | 176

AC Power Electrical Safety Guidelines | 177

AC Power Disconnection Warning | 178

DC Power Disconnection Warning | 179

DC Power Grounding Requirements and Warning | 180

DC Power Wiring Sequence Warning | 181

DC Power Wiring Terminations Warning | 183

Multiple Power Supplies Disconnection Warning | 184

TN Power Warning | 185

Action to Take After an Electrical Accident | 185

Agency Approvals for ACX7100 Routers | 186

Compliance Statements for Data Center | 188

Compliance Statements for EMC Requirements | 188

Compliance Statements for Environmental Requirements | 190

General Safety Guidelines and Warnings

The following guidelines help ensure your safety and protect the device from damage. The list of guidelines might not address all potentially hazardous situations in your working environment, so be alert and exercise good judgment at all times.

- Perform only the procedures explicitly described in the hardware documentation for this device. Make sure that only authorized service personnel perform other system services.
- Keep the area around the device clear and free from dust before, during, and after installation.
- Keep tools away from areas where people could trip over them while walking.
- Do not wear loose clothing or jewelry, such as rings, bracelets, or chains, which could become caught in the device.
- Wear safety glasses if you are working under any conditions that could be hazardous to your eyes.
- Do not perform any actions that create a potential hazard to people or make the equipment unsafe.
- Never attempt to lift an object that is too heavy for one person to handle.
- Never install or manipulate wiring during electrical storms.
- Never install electrical jacks in wet locations unless the jacks are specifically designed for wet environments.
- Operate the device only when it is properly grounded.
- Follow the instructions in this guide to properly ground the device to earth.
- Replace fuses only with fuses of the same type and rating.
- Do not open or remove chassis covers or sheet-metal parts unless instructions are provided in the hardware documentation for this device. Such an action could cause severe electrical shock.
- Do not push or force any objects through any opening in the chassis frame. Such an action could result in electrical shock or fire.
- Avoid spilling liquid onto the chassis or onto any device component. Such an action could cause electrical shock or damage the device.
- Avoid touching uninsulated electrical wires or terminals that have not been disconnected from their power source. Such an action could cause electrical shock.

- Some parts of the chassis, including AC and DC power supply surfaces, power supply unit handles, SFB card handles, and fan tray handles might become hot. The following label provides the warning for hot surfaces on the chassis:



- Always ensure that all modules, power supplies, and cover panels are fully inserted and that the installation screws are fully tightened.

Definitions of Safety Warning Levels

The documentation uses the following levels of safety warnings (there are two *Warning* formats):



NOTE: You might find this information helpful in a particular situation, or you might overlook this important information if it was not highlighted in a Note.



CAUTION: You need to observe the specified guidelines to prevent minor injury or discomfort to you or severe damage to the device.

Attention Veillez à respecter les consignes indiquées pour éviter toute incommodité ou blessure légère, voire des dégâts graves pour l'appareil.



LASER WARNING: This symbol alerts you to the risk of personal injury from a laser.

Avertissement Ce symbole signale un risque de blessure provoquée par rayon laser.



WARNING: This symbol means danger. You are in a situation that could cause bodily injury. Before you work on any equipment, be aware of the hazards involved with electrical circuitry, and familiarize yourself with standard practices for preventing accidents.

Waarschuwing Dit waarschuwingssymbool betekent gevaar. U verkeert in een situatie die lichamelijk letsel kan veroorzaken. Voordat u aan enige apparatuur gaat werken, dient

u zich bewust te zijn van de bij elektrische schakelingen betrokken risico's en dient u op de hoogte te zijn van standaard maatregelen om ongelukken te voorkomen.

Varoitus Tämä varoitusmerkki merkitsee vaaraa. Olet tilanteessa, joka voi johtaa ruumiinvammaan. Ennen kuin työskentelet minkään laitteiston parissa, ota selvää sähkökytkentöihin liittyvistä vaaroista ja tavanomaisista onnettomuuksien ehkäisykeinoista.

Avertissement Ce symbole d'avertissement indique un danger. Vous vous trouvez dans une situation pouvant causer des blessures ou des dommages corporels. Avant de travailler sur un équipement, soyez conscient des dangers posés par les circuits électriques et familiarisez-vous avec les procédures couramment utilisées pour éviter les accidents.

Warnung Dieses Warnsymbol bedeutet Gefahr. Sie befinden sich in einer Situation, die zu einer Körperverletzung führen könnte. Bevor Sie mit der Arbeit an irgendeinem Gerät beginnen, seien Sie sich der mit elektrischen Stromkreisen verbundenen Gefahren und der Standardpraktiken zur Vermeidung von Unfällen bewußt.

Avvertenza Questo simbolo di avvertenza indica un pericolo. La situazione potrebbe causare infortuni alle persone. Prima di lavorare su qualsiasi apparecchiatura, occorre conoscere i pericoli relativi ai circuiti elettrici ed essere al corrente delle pratiche standard per la prevenzione di incidenti.

Advarsel Dette varselsymbolet betyr fare. Du befinner deg i en situasjon som kan føre til personskade. Før du utfører arbeid på utstyr, må du være oppmerksom på de faremomentene som elektriske kretser innebærer, samt gjøre deg kjent med vanlig praksis når det gjelder å unngå ulykker.

Aviso Este símbolo de aviso indica perigo. Encontra-se numa situação que lhe poderá causar danos físicos. Antes de começar a trabalhar com qualquer equipamento, familiarize-se com os perigos relacionados com circuitos eléctricos, e com quaisquer práticas comuns que possam prevenir possíveis acidentes.

¡Atención! Este símbolo de aviso significa peligro. Existe riesgo para su integridad física. Antes de manipular cualquier equipo, considerar los riesgos que entraña la corriente eléctrica y familiarizarse con los procedimientos estándar de prevención de accidentes.

Warning! Denna varningssymbol signalerar fara. Du befinner dig i en situation som kan leda till personskada. Innan du utför arbete på någon utrustning måste du vara medveten om farorna med elkretsar och känna till vanligt förfarande för att förebygga skador.

Qualified Personnel Warning



WARNING: Only trained and qualified personnel should install or replace the device.

Waarschuwing Installatie en reparaties mogen uitsluitend door getraind en bevoegd personeel uitgevoerd worden.

Varoitus Ainoastaan koulutettu ja pätevä henkilökunta saa asentaa tai vaihtaa tämän laitteen.

Avertissement Tout installation ou remplacement de l'appareil doit être réalisé par du personnel qualifié et compétent.

Warnung Gerät nur von geschultem, qualifiziertem Personal installieren oder auswechseln lassen.

Avvertenza Solo personale addestrato e qualificato deve essere autorizzato ad installare o sostituire questo apparecchio.

Advarsel Kun kvalifisert personell med riktig opplæring bør montere eller bytte ut dette utstyret.

Aviso Este equipamento deverá ser instalado ou substituído apenas por pessoal devidamente treinado e qualificado.

¡Atención! Estos equipos deben ser instalados y reemplazados exclusivamente por personal técnico adecuadamente preparado y capacitado.

Warning! Denna utrustning ska endast installeras och bytas ut av utbildad och kvalificerad personal.

Warning Statement for Norway and Sweden



WARNING: The equipment must be connected to an earthed mains socket-outlet.

Advarsel Apparatet skal kobles til en jordet stikkontakt.

Warning! Apparaten skall anslutas till jordat nätuttag.

Fire Safety Requirements

IN THIS SECTION

- [Fire Suppression | 154](#)
- [Fire Suppression Equipment | 154](#)

In the event of a fire emergency, the safety of people is the primary concern. You should establish procedures for protecting people in the event of a fire emergency, provide safety training, and properly provision fire-control equipment and fire extinguishers.

In addition, you should establish procedures to protect your equipment in the event of a fire emergency. Juniper Networks products should be installed in an environment suitable for electronic equipment. We recommend that fire suppression equipment be available in the event of a fire in the vicinity of the equipment and that all local fire, safety, and electrical codes and ordinances be observed when you install and operate your equipment.

Fire Suppression

In the event of an electrical hazard or an electrical fire, you should first turn power off to the equipment at the source. Then use a Type C fire extinguisher, which uses noncorrosive fire retardants, to extinguish the fire.

Fire Suppression Equipment

Type C fire extinguishers, which use noncorrosive fire retardants such as carbon dioxide and Halotron™, are most effective for suppressing electrical fires. Type C fire extinguishers displace oxygen from the point of combustion to eliminate the fire. For extinguishing fire on or around equipment that draws air from the environment for cooling, you should use this type of inert oxygen displacement extinguisher instead of an extinguisher that leaves residues on equipment.

Do not use multipurpose Type ABC chemical fire extinguishers (dry chemical fire extinguishers). The primary ingredient in these fire extinguishers is monoammonium phosphate, which is very sticky and

difficult to clean. In addition, in the presence of minute amounts of moisture, monoammonium phosphate can become highly corrosive and corrodes most metals.

Any equipment in a room in which a chemical fire extinguisher has been discharged is subject to premature failure and unreliable operation. The equipment is considered to be irreparably damaged.



NOTE: To keep warranties effective, do not use a dry chemical fire extinguisher to control a fire at or near a Juniper Networks device. If a dry chemical fire extinguisher is used, the unit is no longer eligible for coverage under a service agreement.

We recommend that you dispose of any irreparably damaged equipment in an environmentally responsible manner.

Installation Instructions Warning



WARNING: Read the installation instructions before you connect the device to a power source.

Waarschuwing Raadpleeg de installatie-aanwijzingen voordat u het systeem met de voeding verbindt.

Varoitus Lue asennusohjeet ennen järjestelmän yhdistämistä virtalähteeseen.

Avertissement Avant de brancher le système sur la source d'alimentation, consulter les directives d'installation.

Warnung Lesen Sie die Installationsanweisungen, bevor Sie das System an die Stromquelle anschließen.

Avvertenza Consultare le istruzioni di installazione prima di collegare il sistema all'alimentatore.

Advarsel Les installasjonsinstruksjonene før systemet kobles til strømkilden.

Aviso Leia as instruções de instalação antes de ligar o sistema à sua fonte de energia.

¡Atención! Ver las instrucciones de instalación antes de conectar el sistema a la red de alimentación.

Varning! Läs installationsanvisningarna innan du kopplar systemet till dess strömförsörjningsenhet.

Chassis and Component Lifting Guidelines

- Before moving the device to a site, ensure that the site meets the power, environmental, and clearance requirements.
- Before lifting or moving the device, disconnect all external cables and wires.
- As when lifting any heavy object, ensure that your legs bear most of the weight rather than your back. Keep your knees bent and your back relatively straight. Do not twist your body as you lift. Balance the load evenly and be sure that your footing is firm.
- Use the following lifting guidelines to lift devices and components:
 - Up to 39.7 lb (18 kg): One person.
 - From 39.7 lb (18 kg) to 70.5 lb (32 kg): Two or more people.
 - From 70.5 lb (32 kg) to 121.2 lb (55 kg): Three or more people.
 - Above 121.2 lb (55 kg): Use material handling systems (such as levers, slings, lifts, and so on). When this is not practical, engage specially trained persons or systems (such as riggers or movers).

Restricted Access Warning



WARNING: This unit is intended for installation in restricted access areas. A restricted access area is an area to which access can be gained only by service personnel through the use of a special tool, lock and key, or other means of security, and which is controlled by the authority responsible for the location.

Waarschuwing Dit toestel is bedoeld voor installatie op plaatsen met beperkte toegang. Een plaats met beperkte toegang is een plaats waar toegang slechts door servicepersoneel verkregen kan worden door middel van een speciaal instrument, een slot en sleutel, of een ander veiligheidsmiddel, en welke beheerd wordt door de overheidsinstantie die verantwoordelijk is voor de locatie.

Varoitus Tämä laite on tarkoitettu asennettavaksi paikkaan, johon pääsy on rajoitettua. Paikka, johon pääsy on rajoitettua, tarkoittaa paikkaa, johon vain huoltohenkilöstö pääsee jonkin erikoistyökalun, lukkoon sopivan avaimen tai jonkin muun turvalaitteen avulla ja joka on paikasta vastuussa olevien toimivaltaisten henkilöiden valvoma.

Avertissement Cet appareil est à installer dans des zones d'accès réservé. Ces dernières sont des zones auxquelles seul le personnel de service peut accéder en utilisant un outil spécial, un mécanisme de verrouillage et une clé, ou tout autre moyen de sécurité. L'accès aux zones de sécurité est sous le contrôle de l'autorité responsable de l'emplacement.

Warnung Diese Einheit ist zur Installation in Bereichen mit beschränktem Zutritt vorgesehen. Ein Bereich mit beschränktem Zutritt ist ein Bereich, zu dem nur Wartungspersonal mit einem Spezialwerkzeugs, Schloß und Schlüssel oder anderer Sicherheitsvorkehrungen Zugang hat, und der von dem für die Anlage zuständigen Gremium kontrolliert wird.

Avvertenza Questa unità deve essere installata in un'area ad accesso limitato. Un'area ad accesso limitato è un'area accessibile solo a personale di assistenza tramite un'attrezzo speciale, lucchetto, o altri dispositivi di sicurezza, ed è controllata dall'autorità responsabile della zona.

Advarsel Denne enheten er laget for installasjon i områder med begrenset adgang. Et område med begrenset adgang gir kun adgang til servicepersonale som bruker et spesielt verktøy, lås og nøkkel, eller en annen sikkerhetsanordning, og det kontrolleres av den autoriteten som er ansvarlig for området.

Aviso Esta unidade foi concebida para instalação em áreas de acesso restrito. Uma área de acesso restrito é uma área à qual apenas tem acesso o pessoal de serviço autorizado, que possua uma ferramenta, chave e fechadura especial, ou qualquer outra forma de segurança. Esta área é controlada pela autoridade responsável pelo local.

¡Atención! Esta unidad ha sido diseñada para instalarse en áreas de acceso restringido. Área de acceso restringido significa un área a la que solamente tiene acceso el personal de servicio mediante la utilización de una herramienta especial, cerradura con llave, o algún otro medio de seguridad, y que está bajo el control de la autoridad responsable del local.

Varning! Denna enhet är avsedd för installation i områden med begränsat tillträde. Ett område med begränsat tillträde får endast tillträdas av servicepersonal med ett speciellt verktyg, lås och nyckel, eller annan säkerhetsanordning, och kontrolleras av den auktoritet som ansvarar för området.

Ramp Warning



WARNING: When installing the device, do not use a ramp inclined at more than 10 degrees.

Waarschuwing Gebruik een oprijplaat niet onder een hoek van meer dan 10 graden.

Varoitus Älä käytä sellaista kaltevaa pintaa, jonka kaltevuus ylittää 10 astetta.

Avertissement Ne pas utiliser une rampe dont l'inclinaison est supérieure à 10 degrés.

Warnung Keine Rampen mit einer Neigung von mehr als 10 Grad verwenden.

Avvertenza Non usare una rampa con pendenza superiore a 10 gradi.

Advarsel Bruk aldri en rampe som heller mer enn 10 grader.

Aviso Não utilize uma rampa com uma inclinação superior a 10 graus.

¡Atención! No usar una rampa inclinada más de 10 grados.

Varning! Använd inte ramp med en lutning på mer än 10 grader.

Rack-Mounting and Cabinet-Mounting Warnings

Ensure that the rack or cabinet in which the device is installed is evenly and securely supported. Uneven mechanical loading could lead to a hazardous condition.



WARNING: To prevent bodily injury when mounting or servicing the device in a rack, take the following precautions to ensure that the system remains stable. The following directives help maintain your safety:

- Install the device in a rack that is secured to the building structure.
- Mount the device at the bottom of the rack if it is the only unit in the rack.
- When mounting the device on a partially filled rack, load the rack from the bottom to the top, with the heaviest component at the bottom of the rack.

- If the rack is provided with stabilizing equipment, install the stabilizers before mounting or servicing the device in the rack.

Waarschuwing Om lichamelijk letsel te voorkomen wanneer u dit toestel in een rek monteert of het daar een servicebeurt geeft, moet u speciale voorzorgsmaatregelen nemen om ervoor te zorgen dat het toestel stabiel blijft. De onderstaande richtlijnen worden verstrekt om uw veiligheid te verzekeren:

- De Juniper Networks switch moet in een stellage worden geïnstalleerd die aan een bouwsel is verankerd.
- Dit toestel dient onderaan in het rek gemonteerd te worden als het toestel het enige in het rek is.
- Wanneer u dit toestel in een gedeeltelijk gevuld rek monteert, dient u het rek van onderen naar boven te laden met het zwaarste onderdeel onderaan in het rek.
- Als het rek voorzien is van stabiliseringshulpmiddelen, dient u de stabilisatoren te monteren voordat u het toestel in het rek monteert of het daar een servicebeurt geeft.

Varoitus Kun laite asetetaan telineeseen tai huolletaan sen ollessa telineessä, on noudatettava erityisiä varotoimia järjestelmän vakavuuden säilyttämiseksi, jotta vältytään loukkaantumiselta. Noudata seuraavia turvallisuusohjeita:

- Juniper Networks switch on asennettava telineeseen, joka on kiinnitetty rakennukseen.
- Jos telineessä ei ole muita laitteita, aseta laite telineen alaosaan.
- Jos laite asetetaan osaksi täytettyyn telineeseen, aloita kuormittaminen sen alaosasta kaikkein raskaimmalla esineellä ja siirry sitten sen yläosaan.
- Jos telinettä varten on vakaimet, asenna ne ennen laitteen asettamista telineeseen tai sen huoltamista siinä.

Avertissement Pour éviter toute blessure corporelle pendant les opérations de montage ou de réparation de cette unité en casier, il convient de prendre des précautions spéciales afin de maintenir la stabilité du système. Les directives ci-dessous sont destinées à assurer la protection du personnel:

- Le rack sur lequel est monté le Juniper Networks switch doit être fixé à la structure du bâtiment.

- Si cette unité constitue la seule unité montée en casier, elle doit être placée dans le bas.
- Si cette unité est montée dans un casier partiellement rempli, charger le casier de bas en haut en plaçant l'élément le plus lourd dans le bas.
- Si le casier est équipé de dispositifs stabilisateurs, installer les stabilisateurs avant de monter ou de réparer l'unité en casier.

Warnung Zur Vermeidung von Körperverletzung beim Anbringen oder Warten dieser Einheit in einem Gestell müssen Sie besondere Vorkehrungen treffen, um sicherzustellen, daß das System stabil bleibt. Die folgenden Richtlinien sollen zur Gewährleistung Ihrer Sicherheit dienen:

- Der Juniper Networks switch muß in einem Gestell installiert werden, das in der Gebäudestruktur verankert ist.
- Wenn diese Einheit die einzige im Gestell ist, sollte sie unten im Gestell angebracht werden.
- Bei Anbringung dieser Einheit in einem zum Teil gefüllten Gestell ist das Gestell von unten nach oben zu laden, wobei das schwerste Bauteil unten im Gestell anzubringen ist.
- Wird das Gestell mit Stabilisierungszubehör geliefert, sind zuerst die Stabilisatoren zu installieren, bevor Sie die Einheit im Gestell anbringen oder sie warten.

Avvertenza Per evitare infortuni fisici durante il montaggio o la manutenzione di questa unità in un supporto, occorre osservare speciali precauzioni per garantire che il sistema rimanga stabile. Le seguenti direttive vengono fornite per garantire la sicurezza personale:

- Il Juniper Networks switch deve essere installato in un telaio, il quale deve essere fissato alla struttura dell'edificio.
- Questa unità deve venire montata sul fondo del supporto, se si tratta dell'unica unità da montare nel supporto.
- Quando questa unità viene montata in un supporto parzialmente pieno, caricare il supporto dal basso all'alto, con il componente più pesante sistemato sul fondo del supporto.
- Se il supporto è dotato di dispositivi stabilizzanti, installare tali dispositivi prima di montare o di procedere alla manutenzione dell'unità nel supporto.

Advarsel Unngå fysiske skader under montering eller reparasjonsarbeid på denne enheten når den befinner seg i et kabinett. Vær nøye med at systemet er stabilt. Følgende retningslinjer er gitt for å verne om sikkerheten:

- Juniper Networks switch må installeres i et stativ som er forankret til bygningsstrukturen.
- Denne enheten bør monteres nederst i kabinettet hvis dette er den eneste enheten i kabinettet.
- Ved montering av denne enheten i et kabinett som er delvis fylt, skal kabinettet lastes fra bunnen og opp med den tyngste komponenten nederst i kabinettet.
- Hvis kabinettet er utstyrt med stabiliseringsutstyr, skal stabilisatorene installeres før montering eller utføring av reparasjonsarbeid på enheten i kabinettet.

Aviso Para se prevenir contra danos corporais ao montar ou reparar esta unidade numa estante, deverá tomar precauções especiais para se certificar de que o sistema possui um suporte estável. As seguintes directrizes ajudá-lo-ão a efectuar o seu trabalho com segurança:

- O Juniper Networks switch deverá ser instalado numa prateleira fixa à estrutura do edifício.
- Esta unidade deverá ser montada na parte inferior da estante, caso seja esta a única unidade a ser montada.
- Ao montar esta unidade numa estante parcialmente ocupada, coloque os itens mais pesados na parte inferior da estante, arrumando-os de baixo para cima.
- Se a estante possuir um dispositivo de estabilização, instale-o antes de montar ou reparar a unidade.

¡Atención! Para evitar lesiones durante el montaje de este equipo sobre un bastidor, oerriormente durante su mantenimiento, se debe poner mucho cuidado en que el sistema quede bien estable. Para garantizar su seguridad, proceda según las siguientes instrucciones:

- El Juniper Networks switch debe instalarse en un bastidor fijado a la estructura del edificio.
- Colocar el equipo en la parte inferior del bastidor, cuando sea la única unidad en el mismo.

- Cuando este equipo se vaya a instalar en un bastidor parcialmente ocupado, comenzar la instalación desde la parte inferior hacia la superior colocando el equipo más pesado en la parte inferior.
- Si el bastidor dispone de dispositivos estabilizadores, instalar éstos antes de montar o proceder al mantenimiento del equipo instalado en el bastidor.

Warning! För att undvika kroppsskada när du installerar eller utför underhållsarbete på denna enhet på en ställning måste du vidta särskilda försiktighetsåtgärder för att försäkra dig om att systemet står stadigt. Följande riktlinjer ges för att trygga din säkerhet:

- Juniper Networks switch måste installeras i en ställning som är förankrad i byggnadens struktur.
- Om denna enhet är den enda enheten på ställningen skall den installeras längst ned på ställningen.
- Om denna enhet installeras på en delvis fylld ställning skall ställningen fyllas nedifrån och upp, med de tyngsta enheterna längst ned på ställningen.
- Om ställningen är försedd med stabiliseringsdon skall dessa monteras fast innan enheten installeras eller underhålls på ställningen.

Grounded Equipment Warning



WARNING: This device must be properly grounded at all times. Follow the instructions in this guide to properly ground the device to earth.

Waarschuwing Dit apparaat moet altijd goed geaard zijn. Volg de instructies in deze gids om het apparaat goed te aarden.

Varoitus Laitteen on oltava pysyvästi maadoitettu. Maadoita laite asianmukaisesti noudattamalla tämän oppaan ohjeita.

Avertissement L'appareil doit être correctement mis à la terre à tout moment. Suivez les instructions de ce guide pour correctement mettre l'appareil à la terre.

Warnung Das Gerät muss immer ordnungsgemäß geerdet sein. Befolgen Sie die Anweisungen in dieser Anleitung, um das Gerät ordnungsgemäß zu erden.

Avvertenza Questo dispositivo deve sempre disporre di una connessione a massa. Seguire le istruzioni indicate in questa guida per connettere correttamente il dispositivo a massa.

Advarsel Denne enheten på jordes skikkelig hele tiden. Følg instruksjonene i denne veiledningen for å jorde enheten.

Aviso Este equipamento deverá estar ligado à terra. Siga las instrucciones en esta guía para conectar correctamente este dispositivo a tierra.

¡Atención! Este dispositivo debe estar correctamente conectado a tierra en todo momento. Siga las instrucciones en esta guía para conectar correctamente este dispositivo a tierra.

Warning! Den här enheten måste vara ordentligt jordad. Följ instruktionerna i den här guiden för att jorda enheten ordentligt.

Radiation from Open Port Apertures Warning



LASER WARNING: Because invisible radiation might be emitted from the aperture of the port when no fiber cable is connected, avoid exposure to radiation and do not stare into open apertures.

Waarschuwing Aangezien onzichtbare straling vanuit de opening van de poort kan komen als er geen fiberkabel aangesloten is, dient blootstelling aan straling en het kijken in open openingen vermeden te worden.

Varoitus Koska portin aukosta voi emittoitua näkymätöntä säteilyä, kun kuitukaapelia ei ole kytkettyä, vältä säteilylle altistumista äläkä katso avoimiin aukkoihin.

Avertissement Des radiations invisibles à l'il nu pouvant traverser l'ouverture du port lorsqu'aucun câble en fibre optique n'y est connecté, il est recommandé de ne pas regarder fixement l'intérieur de ces ouvertures.

Warnung Aus der Port-Öffnung können unsichtbare Strahlen emittieren, wenn kein Glasfaserkabel angeschlossen ist. Vermeiden Sie es, sich den Strahlungen auszusetzen, und starren Sie nicht in die Öffnungen!

Avvertenza Quando i cavi in fibra non sono inseriti, radiazioni invisibili possono essere emesse attraverso l'apertura della porta. Evitate di esporvi alle radiazioni e non guardate direttamente nelle aperture.

Advarsel Unngå utsettelse for stråling, og stirr ikke inn i åpninger som er åpne, fordi usynlig stråling kan emitteres fra portens åpning når det ikke er tilkoblet en fiberkabel.

Aviso Dada a possibilidade de emissão de radiação invisível através do orifício da via de acesso, quando esta não tiver nenhum cabo de fibra conectado, deverá evitar an EXposição à radiação e não deverá olhar fixamente para orifícios que se encontrarem a descoberto.

¡Atención! Debido a que la apertura del puerto puede emitir radiación invisible cuando no existe un cable de fibra conectado, evite mirar directamente a las aperturas para no exponerse a la radiación.

Warning! Osynlig stråling kan avges från en portöppning utan ansluten fiberkabel och du bör därför undvika att bli utsatt för stråling genom att inte stirra in i oskyddade öppningar.

Laser and LED Safety Guidelines and Warnings

IN THIS SECTION

- [General Laser Safety Guidelines | 165](#)
- [Class 1 Laser Product Warning | 165](#)
- [Class 1 LED Product Warning | 166](#)
- [Laser Beam Warning | 166](#)

Juniper Networks devices are equipped with laser transmitters, which are considered a Class 1 Laser Product by the U.S. Food and Drug Administration and are evaluated as a Class 1 Laser Product per IEC/EN 60825-1 requirements.

Observe the following guidelines and warnings:

General Laser Safety Guidelines

When working around ports that support optical transceivers, observe the following safety guidelines to prevent eye injury:

- Do not look into unterminated ports or at fibers that connect to unknown sources.
- Do not examine unterminated optical ports with optical instruments.
- Avoid direct exposure to the beam.



LASER WARNING: Unterminated optical connectors can emit invisible laser radiation. The lens in the human eye focuses all the laser power on the retina, so focusing the eye directly on a laser source—even a low-power laser—could permanently damage the eye.

Avertissement Les connecteurs à fibre optique sans terminaison peuvent émettre un rayonnement laser invisible. Le cristallin de l'œil humain faisant converger toute la puissance du laser sur la rétine, toute focalisation directe de l'œil sur une source laser, — même de faible puissance—, peut entraîner des lésions oculaires irréversibles.

Class 1 Laser Product Warning



LASER WARNING: Class 1 laser product.

Waarschuwing Klasse-1 laser produkt.

Varoitus Luokan 1 lasertuote.

Avertissement Produit laser de classe I.

Warnung Laserprodukt der Klasse 1.

Avvertenza Prodotto laser di Classe 1.

Advarsel Laserprodukt av klasse 1.

Aviso Produto laser de classe 1.

¡Atención! Producto láser Clase I.

Varning! Laserprodukt av klass 1.

Class 1 LED Product Warning



LASER WARNING: Class 1 LED product.

Waarschuwing Klasse 1 LED-product.

Varoitus Luokan 1 valodiodituote.

Avertissement Alarme de produit LED Class I.

Warnung Class 1 LED-Produktwarnung.

Avvertenza Avvertenza prodotto LED di Classe 1.

Advarsel LED-produkt i klasse 1.

Aviso Produto de classe 1 com LED.

¡Atención! Aviso sobre producto LED de Clase 1.

Varning! Lysdiodprodukt av klass 1.

Laser Beam Warning



LASER WARNING: Do not stare into the laser beam or view it directly with optical instruments.

Waarschuwing Niet in de straal staren of hem rechtstreeks bekijken met optische instrumenten.

Varoitus Älä katso säteeseen äläkä tarkastele sitä suoraan optisen laitteen avulla.

Avertissement Ne pas fixer le faisceau des yeux, ni l'observer directement à l'aide d'instruments optiques.

Warnung Nicht direkt in den Strahl blicken und ihn nicht direkt mit optischen Geräten prüfen.

Avvertenza Non fissare il raggio con gli occhi né usare strumenti ottici per osservarlo direttamente.

Advarsel Stirr eller se ikke direkte p strlen med optiske instrumenter.

Aviso Não olhe fixamente para o raio, nem olhe para ele directamente com instrumentos ópticos.

¡Atención! No mirar fijamente el haz ni observarlo directamente con instrumentos ópticos.

Warning! Rikta inte blicken in mot strålen och titta inte direkt på den genom optiska instrument.

Maintenance and Operational Safety Guidelines and Warnings

IN THIS SECTION

- [Battery Handling Warning | 167](#)
- [Jewelry Removal Warning | 168](#)
- [Lightning Activity Warning | 170](#)
- [Operating Temperature Warning | 171](#)
- [Product Disposal Warning | 172](#)

While performing the maintenance activities for devices, observe the following guidelines and warnings:

Battery Handling Warning



WARNING: Replacing a battery incorrectly might result in an explosion. Replace a battery only with the same or equivalent type recommended by the manufacturer. Dispose of used batteries according to the manufacturer's instructions.

Waarschuwing Er is ontploffingsgevaar als de batterij verkeerd vervangen wordt. Vervang de batterij slechts met hetzelfde of een equivalent type dat door de fabrikant

aanbevolen is. Gebruikte batterijen dienen overeenkomstig fabrieksvoorschriften weggeworpen te worden.

Varoitus Räjähdyksen vaara, jos akku on vaihdettu väärään akkuun. Käytä vaihtamiseen ainoastaan saman- tai vastaavantyyppistä akkua, joka on valmistajan suosittelema. Hävitä käytetyt akut valmistajan ohjeiden mukaan.

Avertissement Danger d'explosion si la pile n'est pas remplacée correctement. Ne la remplacer que par une pile de type semblable ou équivalent, recommandée par le fabricant. Jeter les piles usagées conformément aux instructions du fabricant.

Warnung Bei Einsetzen einer falschen Batterie besteht Explosionsgefahr. Ersetzen Sie die Batterie nur durch den gleichen oder vom Hersteller empfohlenen Batterietyp. Entsorgen Sie die benutzten Batterien nach den Anweisungen des Herstellers.

Advarsel Det kan være fare for eksplosjon hvis batteriet skiftes på feil måte. Skift kun med samme eller tilsvarende type som er anbefalt av produsenten. Kasser brukte batterier i henhold til produsentens instruksjoner.

Avvertenza Pericolo di esplosione se la batteria non è installata correttamente. Sostituire solo con una di tipo uguale o equivalente, consigliata dal produttore. Eliminare le batterie usate secondo le istruzioni del produttore.

Aviso Existe perigo de explosão se a bateria for substituída incorrectamente. Substitua a bateria por uma bateria igual ou de um tipo equivalente recomendado pelo fabricante. Destrua as baterias usadas conforme as instruções do fabricante.

¡Atención! Existe peligro de explosión si la batería se reemplaza de manera incorrecta. Reemplazar la batería EXclusivamente con el mismo tipo o el equivalente recomendado por el fabricante. Desechar las baterías gastadas según las instrucciones del fabricante.

Warning! Explosionsfara vid felaktigt batteribyte. Ersätt endast batteriet med samma batterityp som rekommenderas av tillverkaren eller motsvarande. Följ tillverkarens anvisningar vid kassering av använda batterier.

Jewelry Removal Warning



WARNING: Before working on equipment that is connected to power lines, remove jewelry, including rings, necklaces, and watches. Metal objects heat up when connected to power and ground and can cause serious burns or can be welded to the terminals.

Waarschuwing Alvorens aan apparatuur te werken die met elektrische leidingen is verbonden, sieraden (inclusief ringen, kettingen en horloges) verwijderen. Metalen voorwerpen worden warm wanneer ze met stroom en aarde zijn verbonden, en kunnen ernstige brandwonden veroorzaken of het metalen voorwerp aan de aansluitklemmen lassen.

Varoitus Ennen kuin työskentelet voimavirtajohtoihin kytkettyjen laitteiden parissa, ota pois kaikki korut (sormukset, kaulakorut ja kellot mukaan lukien). Metalliesineet kuumenevat, kun ne ovat yhteydessä sähkövirran ja maan kanssa, ja ne voivat aiheuttaa vakavia palovammoja tai hitsata metalliesineet kiinni liitäntänapoihin.

Avertissement Avant d'accéder à cet équipement connecté aux lignes électriques, ôter tout bijou (anneaux, colliers et montres compris). Lorsqu'ils sont branchés à l'alimentation et reliés à la terre, les objets métalliques chauffent, ce qui peut provoquer des blessures graves ou souder l'objet métallique aux bornes.

Warnung Vor der Arbeit an Geräten, die an das Netz angeschlossen sind, jeglichen Schmuck (einschließlich Ringe, Ketten und Uhren) abnehmen. Metallgegenstände erhitzen sich, wenn sie an das Netz und die Erde angeschlossen werden, und können schwere Verbrennungen verursachen oder an die Anschlußklemmen angeschweißt werden.

Avvertenza Prima di intervenire su apparecchiature collegate alle linee di alimentazione, togliersi qualsiasi monile (inclusi anelli, collane, braccialetti ed orologi). Gli oggetti metallici si riscaldano quando sono collegati tra punti di alimentazione e massa: possono causare ustioni gravi oppure il metallo può saldarsi ai terminali.

Advarsel Fjern alle smykker (inkludert ringer, halskjeder og klokker) før du skal arbeide på utstyr som er koblet til kraftledninger. Metallgjenstander som er koblet til kraftledninger og jord blir svært varme og kan forårsake alvorlige brannskader eller smelte fast til polene.

Aviso Antes de trabalhar em equipamento que esteja ligado a linhas de corrente, retire todas as jóias que estiver a usar (incluindo anéis, fios e relógios). Os objectos metálicos aquecerão em contacto com a corrente e em contacto com a ligação à terra, podendo causar queimaduras graves ou ficarem soldados aos terminais.

¡Atención! Antes de operar sobre equipos conectados a líneas de alimentación, quitarse las joyas (incluidos anillos, collares y relojes). Los objetos de metal se calientan cuando se conectan a la alimentación y a tierra, lo que puede ocasionar quemaduras graves o que los objetos metálicos queden soldados a los bornes.

Warning! Tag av alla smycken (inklusive ringar, halsband och armbandsur) innan du arbetar på utrustning som är kopplad till kraftledning. Metallobjekt hettas upp när de kopplas ihop med ström och jord och kan förorsaka allvarliga brännskador; metallobjekt kan också sammansvetsas med kontakterna.

Lightning Activity Warning



WARNING: Do not work on the system or connect or disconnect cables during periods of lightning activity.

Waarschuwing Tijdens onweer dat gepaard gaat met bliksem, dient u niet aan het systeem te werken of kabels aan te sluiten of te ontkoppelen.

Varoitus Älä työskentele järjestelmän parissa äläkä yhdistä tai irrota kaapeleita ukkosilmalla.

Avertissement Ne pas travailler sur le système ni brancher ou débrancher les câbles pendant un orage.

Warnung Arbeiten Sie nicht am System und schließen Sie keine Kabel an bzw. trennen Sie keine ab, wenn es gewittert.

Avvertenza Non lavorare sul sistema o collegare oppure scollegare i cavi durante un temporale con fulmini.

Advarsel Utfør aldri arbeid på systemet, eller koble kabler til eller fra systemet når det tordner eller lyner.

Aviso Não trabalhe no sistema ou ligue e desligue cabos durante períodos de mau tempo (trovoada).

¡Atención! No operar el sistema ni conectar o desconectar cables durante el transcurso de descargas eléctricas en la atmósfera.

Warning! Vid åska skall du aldrig utföra arbete på systemet eller ansluta eller koppla loss kablar.

Operating Temperature Warning



WARNING: To prevent the device from overheating, do not operate it in an area that exceeds the maximum recommended ambient temperature. To prevent airflow restriction, allow at least 6 in. (15.2 cm) of clearance around the ventilation openings.

Waarschuwing Om te voorkomen dat welke switch van de Juniper Networks router dan ook oververhit raakt, dient u deze niet te bedienen op een plaats waar de maximale aanbevolen omgevingstemperatuur van 40° C wordt overschreden. Om te voorkomen dat de luchtstroom wordt beperkt, dient er minstens 15,2 cm speling rond de ventilatie-openingen te zijn.

Varoitus Ettei Juniper Networks switch-sarjan reititin ylikuumentuisi, sitä ei saa käyttää tilassa, jonka lämpötila ylittää korkeimman suositellun ympäristölämpötilan 40° C. Ettei ilmanvaihto estyisi, tuuletusaukkojen ympärille on jätettävä ainakin 15,2 cm tilaa.

Avertissement Pour éviter toute surchauffe des routeurs de la gamme Juniper Networks switch, ne l'utilisez pas dans une zone où la température ambiante est supérieure à 40° C. Pour permettre un flot d'air constant, dégagez un espace d'au moins 15,2 cm autour des ouvertures de ventilations.

Warnung Um einen Router der switch vor Überhitzung zu schützen, darf dieser nicht in einer Gegend betrieben werden, in der die Umgebungstemperatur das empfohlene Maximum von 40° C überschreitet. Um Lüftungsverschluß zu verhindern, achten Sie darauf, daß mindestens 15,2 cm lichter Raum um die Lüftungsöffnungen herum frei bleibt.

Avvertenza Per evitare il surriscaldamento dei switch, non adoperateli in un locale che ecceda la temperatura ambientale massima di 40° C. Per evitare che la circolazione dell'aria sia impedita, lasciate uno spazio di almeno 15.2 cm di fronte alle aperture delle ventole.

Advarsel Unngå overoppheting av eventuelle rutere i Juniper Networks switch Disse skal ikke brukes på steder der den anbefalte maksimale omgivelsestemperaturen overstiger 40° C (104° F). Sørg for at klaringen rundt lufteåpningene er minst 15,2 cm (6 tommer) for å forhindre nedsatt luftsirkulasjon.

Aviso Para evitar o sobreaquecimento do encaminhador Juniper Networks switch, não utilize este equipamento numa área que exceda a temperatura máxima recomendada de 40° C. Para evitar a restrição à circulação de ar, deixe pelo menos um espaço de 15,2 cm à volta das aberturas de ventilação.

¡Atención! Para impedir que un encaminador de la serie Juniper Networks switch se recaliente, no lo haga funcionar en un área en la que se supere la temperatura ambiente máxima recomendada de 40° C. Para impedir la restricción de la entrada de aire, deje un espacio mínimo de 15,2 cm alrededor de las aperturas para ventilación.

Warning! Förhindra att en Juniper Networks switch överhettas genom att inte använda den i ett område där den maximalt rekommenderade omgivningstemperaturen på 40° C överskrids. Förhindra att luftcirkulationen inskränks genom att se till att det finns fritt utrymme på minst 15,2 cm omkring ventilationsöppningarna.

Product Disposal Warning



WARNING: Disposal of this device must be handled according to all national laws and regulations.

Waarschuwing Dit produkt dient volgens alle landelijke wetten en voorschriften te worden afgedankt.

Varoitus Tämän tuotteen lopullisesta hävittämisestä tulee huolehtia kaikkia valtakunnallisia lakeja ja säännöksiä noudattaen.

Avertissement La mise au rebut définitive de ce produit doit être effectuée conformément à toutes les lois et réglementations en vigueur.

Warnung Dieses Produkt muß den geltenden Gesetzen und Vorschriften entsprechend entsorgt werden.

Avvertenza L'eliminazione finale di questo prodotto deve essere eseguita osservando le normative italiane vigenti in materia

Advarsel Endelig disponering av dette produktet må skje i henhold til nasjonale lover og forskrifter.

Aviso A descartagem final deste produto deverá ser efectuada de acordo com os regulamentos e a legislação nacional.

¡Atención! El desecho final de este producto debe realizarse según todas las leyes y regulaciones nacionales

Warning! Slutlig kassering av denna produkt bör skötas i enlighet med landets alla lagar och föreskrifter.

General Electrical Safety Guidelines and Warnings



WARNING: Certain ports on the device are designed for use as intrabuilding (within-the-building) interfaces only (Type 2 or Type 4 ports as described in *GR-1089-CORE*) and require isolation from the exposed outside plant (OSP) cabling. To comply with NEBS (Network Equipment-Building System) requirements and protect against lightning surges and commercial power disturbances, the intrabuilding ports *must not* be metallically connected to interfaces that connect to the OSP or its wiring. The intrabuilding ports on the device are suitable for connection to intrabuilding or unexposed wiring or cabling only. The addition of primary protectors is not sufficient protection for connecting these interfaces metallically to OSP wiring.

Avertissement Certains ports de l'appareil sont destinés à un usage en intérieur uniquement (ports Type 2 ou Type 4 tels que décrits dans le document *GR-1089-CORE*) et doivent être isolés du câblage de l'installation extérieure exposée. Pour respecter les exigences NEBS et assurer une protection contre la foudre et les perturbations de tension secteur, les ports pour intérieur *ne doivent pas* être raccordés physiquement aux interfaces prévues pour la connexion à l'installation extérieure ou à son câblage. Les ports pour intérieur de l'appareil sont réservés au raccordement de câbles pour intérieur ou non exposés uniquement. L'ajout de protections ne constitue pas une précaution suffisante pour raccorder physiquement ces interfaces au câblage de l'installation extérieure.



CAUTION: Before removing or installing components of a device, connect an electrostatic discharge (ESD) grounding strap to an ESD point and wrap and fasten the other end of the strap around your bare wrist. Failure to use an ESD grounding strap could result in damage to the device.

Attention Avant de retirer ou d'installer des composants d'un appareil, raccordez un bracelet antistatique à un point de décharge électrostatique et fixez le bracelet à votre poignet nu. L'absence de port d'un bracelet antistatique pourrait provoquer des dégâts sur l'appareil.

- Install the device in compliance with the following local, national, and international electrical codes:
 - United States—National Fire Protection Association (NFPA 70), United States National Electrical Code.
 - Other countries—International Electromechanical Commission (IEC) 60364, Part 1 through Part 7.
 - Evaluated to the TN power system.

- Canada—Canadian Electrical Code, Part 1, CSA C22.1.
- Suitable for installation in Information Technology Rooms in accordance with Article 645 of the National Electrical Code and NFPA 75.

Peut être installé dans des salles de matériel de traitement de l'information conformément à l'article 645 du National Electrical Code et à la NFPA 75.

- Locate the emergency power-off switch for the room in which you are working so that if an electrical accident occurs, you can quickly turn off the power.
- Make sure that you clean grounding surface and give them a bright finish before making grounding connections.
- Do not work alone if potentially hazardous conditions exist anywhere in your workspace.
- Never assume that power is disconnected from a circuit. Always check the circuit before starting to work.
- Carefully look for possible hazards in your work area, such as moist floors, ungrounded power extension cords, and missing safety grounds.
- Operate the device within marked electrical ratings and product usage instructions.
- To ensure that the device and peripheral equipment function safely and correctly, use the cables and connectors specified for the attached peripheral equipment, and make certain they are in good condition.

You can remove and replace many device components without powering off or disconnecting power to the device, as detailed elsewhere in the hardware documentation for this device. Never install equipment that appears to be damaged.

Prevention of Electrostatic Discharge Damage

Device components that are shipped in antistatic bags are sensitive to damage from static electricity. Some components can be impaired by voltages as low as 30 V. You can easily generate potentially damaging static voltages whenever you handle plastic or foam packing material or if you move components across plastic or carpets. Observe the following guidelines to minimize the potential for electrostatic discharge (ESD) damage, which can cause intermittent or complete component failures:

- Always use an ESD wrist strap when you are handling components that are subject to ESD damage, and make sure that it is in direct contact with your skin.

If a grounding strap is not available, hold the component in its antistatic bag (see [Figure 78 on page 175](#)) in one hand and touch the exposed, bare metal of the device with the other hand immediately before inserting the component into the device.



WARNING: For safety, periodically check the resistance value of the ESD grounding strap. The measurement must be in the range 1 through 10 Mohms.

Avertissement Par mesure de sécurité, vérifiez régulièrement la résistance du bracelet antistatique. Cette valeur doit être comprise entre 1 et 10 mégohms (Mohms).

- When handling any component that is subject to ESD damage and that is removed from the device, make sure the equipment end of your ESD wrist strap is attached to the ESD point on the chassis.

If no grounding strap is available, touch the exposed, bare metal of the device to ground yourself before handling the component.

- Avoid contact between the component that is subject to ESD damage and your clothing. ESD voltages emitted from clothing can damage components.
- When removing or installing a component that is subject to ESD damage, always place it component-side up on an antistatic surface, in an antistatic card rack, or in an antistatic bag (see [Figure 78 on page 175](#)). If you are returning a component, place it in an antistatic bag before packing it.

Figure 78: Placing a Component into an Antistatic Bag

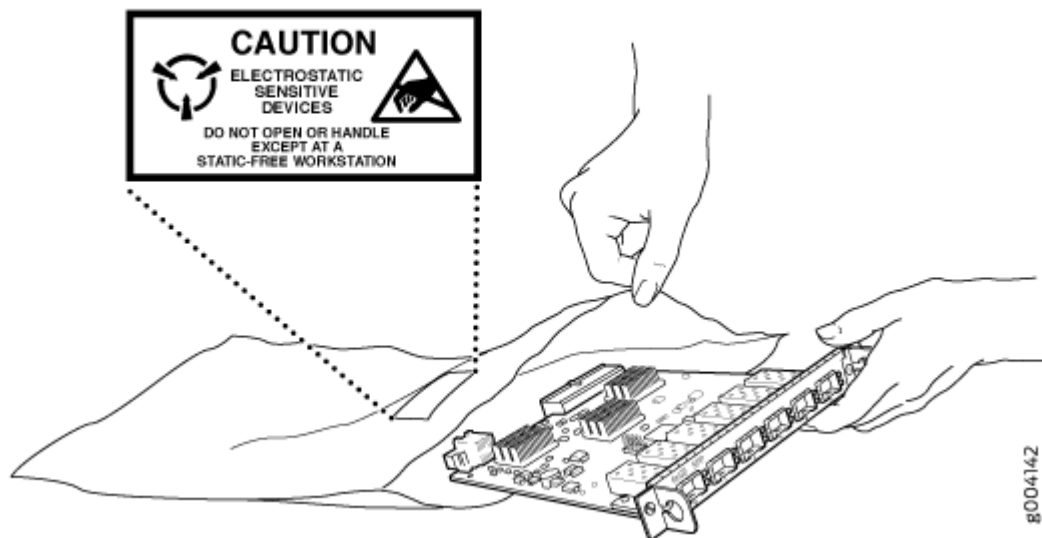

8004142



CAUTION: ANSI/TIA/EIA-568 cables such as Category 5e and Category 6 can get electrostatically charged. To dissipate this charge, always ground the cables to a suitable and safe earth ground before connecting them to the system.

Attention Les câbles ANSI/TIA/EIA-568, par exemple Cat 5e et Cat 6, peuvent emmagasiner des charges électrostatiques. Pour évacuer ces charges, reliez toujours les câbles à une prise de terre adaptée avant de les raccorder au système.

Site Electrical Wiring Guidelines

Table 34 on page 176 describes the factors you must consider while planning the electrical wiring at your site.



WARNING: You must provide a properly grounded and shielded environment and use electrical surge-suppression devices.

Avertissement Vous devez établir un environnement protégé et convenablement mis à la terre et utiliser des dispositifs de parasurtension.

Table 34: Site Electrical Wiring Guidelines

Site Wiring Factor	Guidelines
Signaling limitations	<p>If your site experiences any of the following problems, consult experts in electrical surge suppression and shielding:</p> <ul style="list-style-type: none"> • Radio frequency interference (RFI) because of improperly installed wires • Damage from lightning strikes occurring when wires exceed recommended distances or pass between buildings • Electromagnetic pulses (EMPs) caused by lightning damaging unshielded conductors and electronic devices

Table 34: Site Electrical Wiring Guidelines (Continued)

Site Wiring Factor	Guidelines
Radio frequency interference	<p>To reduce or eliminate RFI from your site wiring, do the following:</p> <ul style="list-style-type: none"> • Use a twisted-pair cable with a good distribution of grounding conductors. • To exceed the recommended distances, use a high-quality twisted-pair cable with one ground conductor for each data signal, when applicable.
Electromagnetic compatibility	<p>If your site is susceptible to problems with electromagnetic compatibility (EMC), particularly from lightning or radio transmitters, seek expert advice.</p> <p>Strong sources of electromagnetic interference (EMI) can cause:</p> <ul style="list-style-type: none"> • Destruction of the signal drivers and receivers in the device. • Electrical hazards as a result of power surges conducted over the lines into the equipment.

AC Power Electrical Safety Guidelines

The following electrical safety guidelines apply to AC-powered devices:

- Note the following warnings printed on the device:

“CAUTION: THIS UNIT HAS MORE THAN ONE POWER SUPPLY CORD. DISCONNECT ALL POWER SUPPLY CORDS BEFORE SERVICING TO AVOID ELECTRIC SHOCK.”

“ATTENTION: CET APPAREIL COMPORTE PLUS D'UN CORDON D'ALIMENTATION. AFIN DE PRÉVENIR LES CHOCS ÉLECTRIQUES, DÉBRANCHER TOUT CORDON D'ALIMENTATION AVANT DE FAIRE LE DÉPANNAGE.”

- AC-powered devices are shipped with a three-wire electrical cord with a grounding-type plug that fits only a grounding-type power outlet. Do not circumvent this safety feature. Equipment grounding must comply with local and national electrical codes.
- You must provide an external certified circuit breaker (2-pole circuit breaker or 4-pole circuit breaker based on your device) rated minimum 20 A in the building installation.

- The power cord serves as the main disconnecting device for the AC-powered device. The socket outlet must be near the AC-powered device and be easily accessible.
- For devices that have more than one power supply connection, you must ensure that all power connections are fully disconnected so that power to the device is completely removed to prevent electric shock. To disconnect power, unplug all power cords (one for each power supply).

Power Cable Warning (Japanese)

WARNING: The attached power cable is only for this product. Do not use the cable for another product.

注意

附属の電源コードセットはこの製品専用です。
他の電気機器には使用しないでください。

9477283

AC Power Disconnection Warning



WARNING: Before working on the device or near power supplies, unplug all the power cords from an AC-powered device.

Waarschuwing Voordat u aan een frame of in de nabijheid van voedingen werkt, dient u bij wisselstroom toestellen de stekker van het netsnoer uit het stopcontact te halen.

Varoitus Kytke irti vaihtovirtalaitteiden virtajohto, ennen kuin teet mitään asennuspohjalle tai työskentelet virtalähteiden läheisyydessä.

Avertissement Avant de travailler sur un châssis ou à proximité d'une alimentation électrique, débrancher le cordon d'alimentation des unités en courant alternatif.

Warnung Bevor Sie an einem Chassis oder in der Nähe von Netzgeräten arbeiten, ziehen Sie bei Wechselstromeinheiten das Netzkabel ab bzw.

Avvertenza Prima di lavorare su un telaio o intorno ad alimentatori, scollegare il cavo di alimentazione sulle unità CA.

Advarsel Før det utføres arbeid på kabinettet eller det arbeides i nærheten av strømforsyningsenheter, skal strømledningen trekkes ut på vekselstrømsenheter.

Aviso Antes de trabalhar num chassis, ou antes de trabalhar perto de unidades de fornecimento de energia, desligue o cabo de alimentação nas unidades de corrente alternada.

¡Atención! Antes de manipular el chasis de un equipo o trabajar cerca de una fuente de alimentación, desenchufar el cable de alimentación en los equipos de corriente alterna (CA).

Warning! Innan du arbetar med ett chassi eller nära strömförsörjningsenheter skall du för växelströmsenheter dra ur nätsladden.

DC Power Disconnection Warning



WARNING: Before performing any of the DC power procedures, ensure that power is removed from the DC circuit. To ensure that all power is off, locate the circuit breaker on the panel board that services the DC circuit, switch the circuit breaker to the OFF position, and tape the device handle of the circuit breaker in the OFF position.

Waarschuwing Voordat u een van de onderstaande procedures uitvoert, dient u te controleren of de stroom naar het gelijkstroom circuit uitgeschakeld is. Om u ervan te verzekeren dat alle stroom UIT is geschakeld, kiest u op het schakelbord de stroomverbreker die het gelijkstroom circuit bedient, draait de stroomverbreker naar de UIT positie en plakt de schakelaarhendel van de stroomverbreker met plakband in de UIT positie vast.

Varoitus Varmista, että tasavirtapiirissä ei ole virtaa ennen seuraavien toimenpiteiden suorittamista. Varmistaaksesi, että virta on KATKAISTU täysin, paikanna tasavirrasta huolehtivassa kojetaulussa sijaitseva suojakytkin, käänä suojakytkin KATKAISTU-asentoon ja teippaa suojakytkimen varsi niin, että se pysyy KATKAISTU-asennossa.

Avertissement Avant de pratiquer l'une quelconque des procédures ci-dessous, vérifier que le circuit en courant continu n'est plus sous tension. Pour en être sûr, localiser le disjoncteur situé sur le panneau de service du circuit en courant continu, placer le disjoncteur en position fermée (OFF) et, à l'aide d'un ruban adhésif, bloquer la poignée du disjoncteur en position OFF.

Warnung Vor Ausführung der folgenden Vorgänge ist sicherzustellen, daß die Gleichstromschaltung keinen Strom erhält. Um sicherzustellen, daß sämtlicher Strom abgestellt ist, machen Sie auf der Schalttafel den Unterbrecher für die

Gleichstromschaltung ausfindig, stellen Sie den Unterbrecher auf AUS, und kleben Sie den Schaltergriff des Unterbrechers mit Klebeband in der AUS-Stellung fest.

Avvertenza Prima di svolgere una qualsiasi delle procedure seguenti, verificare che il circuito CC non sia alimentato. Per verificare che tutta l'alimentazione sia scollegata (OFF), individuare l'interruttore automatico sul quadro strumenti che alimenta il circuito CC, mettere l'interruttore in posizione OFF e fissarlo con nastro adesivo in tale posizione.

Advarsel Før noen av disse prosedyrene utføres, kontroller at strømmen er frakoblet likestrømkretsen. Sørg for at all strøm er slått AV. Dette gjøres ved å lokalisere strømbryteren på brytertavlen som betjener likestrømkretsen, slå strømbryteren AV og teipe bryterhåndtaket på strømbryteren i AV-stilling.

Aviso Antes de executar um dos seguintes procedimentos, certifique-se que desligou a fonte de alimentação de energia do circuito de corrente contínua. Para se assegurar que toda a corrente foi DESLIGADA, localize o disjuntor no painel que serve o circuito de corrente contínua e coloque-o na posição OFF (Desligado), segurando nessa posição a manivela do interruptor do disjuntor com fita isoladora.

¡Atención! Antes de proceder con los siguientes pasos, comprobar que la alimentación del circuito de corriente continua (CC) esté cortada (OFF). Para asegurarse de que toda la alimentación esté cortada (OFF), localizar el interruptor automático en el panel que alimenta al circuito de corriente continua, cambiar el interruptor automático a la posición de Apagado (OFF), y sujetar con cinta la palanca del interruptor automático en posición de Apagado (OFF).

Warning! Innan du utför någon av följande procedurer måste du kontrollera att strömförsörjningen till likströmskretsen är bruten. Kontrollera att all strömförsörjning är BRUTEN genom att slå AV det överspänningsskydd som skyddar likströmskretsen och tejpa fast överspänningsskyddets omkopplare i FRÅN-läget.

DC Power Grounding Requirements and Warning

An insulated grounding conductor that is identical in size to the grounded and ungrounded branch circuit supply conductors but is identifiable by green and yellow stripes is installed as part of the branch circuit that supplies the device. The grounding conductor is a separately derived system at the supply transformer or motor generator set.



WARNING: When you install the device, the ground connection must always be made first and disconnected last.

Waarschuwing Bij de installatie van het toestel moet de aardverbinding altijd het eerste worden gemaakt en het laatste worden losgemaakt.

Varoitus Laitetta asennettaessa on maahan yhdistäminen aina tehtävä ensiksi ja maadoituksen irti kytkeminen viimeiseksi.

Avertissement Lors de l'installation de l'appareil, la mise à la terre doit toujours être connectée en premier et déconnectée en dernier.

Warnung Der Erdanschluß muß bei der Installation der Einheit immer zuerst hergestellt und zuletzt abgetrennt werden.

Avvertenza In fase di installazione dell'unità, eseguire sempre per primo il collegamento a massa e disconnetterlo per ultimo.

Advarsel Når enheten installeres, må jordledningen alltid tilkobles først og frakobles sist.

Aviso Ao instalar a unidade, a ligação à terra deverá ser sempre a primeira a ser ligada, e a última a ser desligada.

¡Atención! Al instalar el equipo, conectar la tierra la primera y desconectarla la última.

Varning! Vid installation av enheten måste jordledningen alltid anslutas först och kopplas bort sist.

DC Power Wiring Sequence Warning



WARNING: Wire the DC power supply using the appropriate lugs. When connecting power, the proper wiring sequence is ground to ground, +RTN to +RTN, then -48 V to -48 V. When disconnecting power, the proper wiring sequence is -48 V to -48 V, +RTN to +RTN, then ground to ground. Note that the ground wire must always be connected first and disconnected last.

Waarschuwing De juiste bedradingsvolgorde verbonden is aarde naar aarde, +RTN naar +RTN, en -48 V naar -48 V. De juiste bedradingsvolgorde losgemaakt is en -48 naar -48 V, +RTN naar +RTN, aarde naar aarde.

Varoitus Oikea yhdistettävä kytkentäjärjestys on maajohto maajohtoon, +RTN varten +RTN, -48 V varten - 48 V. Oikea irrotettava kytkentäjärjestys on -48 V varten - 48 V, +RTN varten +RTN, maajohto maajohtoon.

Avertissement Câblez l'alimentation d'alimentation CC En utilisant les crochets appropriés à l'extrémité de câblage. En reliant la puissance, l'ordre approprié de câblage est rectifié pour rectifier, +RTN à +RTN, puis -48 V à -48 V. En débranchant la puissance, l'ordre approprié de câblage est -48 V à -48 V, +RTN à +RTN, a alors rectifié pour rectifier. Notez que le fil de masse devrait toujours être relié d'abord et débranché pour la dernière fois. Notez que le fil de masse devrait toujours être relié d'abord et débranché pour la dernière fois.

Warnung Die Stromzufuhr ist nur mit geeigneten Ringösen an das DC Netzteil anzuschliessen. Die richtige Anschlusssequenz ist: Erdanschluss zu Erdanschluss, +RTN zu +RTN und dann -48V zu -48V. Die richtige Sequenz zum Abtrennen der Stromversorgung ist -48V zu -48V, +RTN zu +RTN und dann Erdanschluss zu Erdanschluss. Es ist zu beachten dass der Erdanschluss immer zuerst angeschlossen und als letztes abgetrennt wird.

Avvertenza Mostra la morsettiera dell alimentatore CC. Cablare l'alimentatore CC usando i connettori adatti all'estremità del cablaggio, come illustrato. La corretta sequenza di cablaggio è da massa a massa, da positivo a positivo (da linea ad L) e da negativo a negativo (da neutro a N). Tenere presente che il filo di massa deve sempre venire collegato per primo e scollegato per ultimo.

Advarsel Riktig tilkoples tilkoplingssekvens er jord til jord, +RTN til +RTN, -48 V til -48 V. Riktig frakoples tilkoplingssekvens er -48 V til -48 V, +RTN til +RTN, jord til jord.

Aviso Ate con alambre la fuente de potencia cc Usando los terminales apropiados en el extremo del cableado. Al conectar potencia, la secuencia apropiada del cableado se muele para moler, +RTN a +RTN, entonces -48 V a -48 V. Al desconectar potencia, la secuencia apropiada del cableado es -48 V a -48 V, +RTN a +RTN, entonces molió para moler. Observe que el alambre de tierra se debe conectar siempre primero y desconectar por último. Observe que el alambre de tierra se debe conectar siempre primero y desconectar por último.

¡Atención! Wire a fonte de alimentação de DC Usando os talões apropriados na Extremidade da fiação. Ao conectar a potência, a seqüência apropriada da fiação é moída para moer, +RTN a +RTN, então -48 V a -48 V. Ao desconectar a potência, a seqüência apropriada da fiação é -48 V a -48 V, +RTN a +RTN, moeu então para moer. Anote que o fio à terra deve sempre ser conectado primeiramente e desconectado por último. Anote que o fio à terra deve sempre ser conectado primeiramente e desconectado por último.

Warning! Korrekt kopplingssekvens ar jord till jord, +RTN till +RTN, -48 V till -48 V.
Korrekt kopplas kopplingssekvens ar -48 V till -48 V, +RTN till +RTN, jord till jord.

DC Power Wiring Terminations Warning



WARNING: When stranded wiring is required, use approved wiring terminations, such as closed-loop or spade-type with upturned lugs. These terminations must be the appropriate size for the wires and must clamp both the insulation and conductor.

Waarschuwing Wanneer geslagen bedrading vereist is, dient u bedrading te gebruiken die voorzien is van goedgekeurde aansluitingspunten, zoals het gesloten-lus type of het grijperschop type waarbij de aansluitpunten omhoog wijzen. Deze aansluitpunten dienen de juiste maat voor de draden te hebben en dienen zowel de isolatie als de geleider vast te klemmen.

Varoitus Jos säikeellinen johdin on tarpeen, käytä hyväksyttyä johdinliitääntää, esimerkiksi suljettua silmukkaa tai kourumaista liitääntää, jossa on ylöspäin käännetyt kiinnityskorvat. Tällaisten liitäntöjen tulee olla kooltaan johtimiin sopivia ja niiden tulee puristaa yhteen sekä eristeen että johdinosan.

Avertissement Quand des fils torsadés sont nécessaires, utiliser des douilles terminales homologuées telles que celles à circuit fermé ou du type à plage ouverte avec cosses rebroussées. Ces douilles terminales doivent être de la taille qui convient aux fils et doivent être refermées sur la gaine isolante et sur le conducteur.

Warnung Wenn Litzenverdrahtung erforderlich ist, sind zugelassene Verdrahtungsabschlüsse, z.B. für einen geschlossenen Regelkreis oder gabelförmig, mit nach oben gerichteten Kabelschuhen zu verwenden. Diese Abschlüsse sollten die angemessene Größe für die Drähte haben und sowohl die Isolierung als auch den Leiter festklemmen.

Avvertenza Quando occorre usare trecce, usare connettori omologati, come quelli a occhiello o a forcella con linguette rivolte verso l'alto. I connettori devono avere la misura adatta per il cablaggio e devono serrare sia l'isolante che il conduttore.

Advarsel Hvis det er nødvendig med flertrådede ledninger, brukes godkjente ledningsavslutninger, som for eksempel lukket sløyfe eller spadetype med oppoverbøyde kabelsko. Disse avslutningene skal ha riktig størrelse i forhold til ledningene, og skal klemme sammen både isolasjonen og ledere.

Aviso Quando forem requeridas montagens de instalação eléctrica de cabo torcido, use terminações de cabo aprovadas, tais como, terminações de cabo em circuito fechado e planas com terminais de orelha voltados para cima. Estas terminações de cabo deverão ser do tamanho apropriado para os respectivos cabos, e deverão prender simultaneamente o isolamento e o fio condutor.

¡Atención! Cuando se necesite hilo trenzado, utilizar terminales para cables homologados, tales como las de tipo "bucle cerrado" o "espada", con las lengüetas de conexión vueltas hacia arriba. Estos terminales deberán ser del tamaño apropiado para los cables que se utilicen, y tendrán que sujetar tanto el aislante como el conductor.

Warning! När flertrådiga ledningar krävs måste godkända ledningskontakter användas, t.ex. kabelsko av slutet eller öppen typ med uppåtvänd tapp. Storleken på dessa kontakter måste vara avpassad till ledningarna och måste kunna hålla både isoleringen och ledaren fastklämda.

Multiple Power Supplies Disconnection Warning



WARNING: The network device has more than one power supply connection. All connections must be removed completely to remove power from the unit completely.

Waarschuwing Deze eenheid heeft meer dan één stroomtoevoerverbinding; alle verbindingen moeten volledig worden verwijderd om de stroom van deze eenheid volledig te verwijderen.

Varoitus Tässä laitteessa on useampia virtalähdekytkentöjä. Kaikki kytkennät on irrotettava kokonaan, jotta virta poistettaisiin täysin laitteesta.

Avertissement Cette unité est équipée de plusieurs raccordements d'alimentation. Pour supprimer tout courant électrique de l'unité, tous les cordons d'alimentation doivent être débranchés.

Warnung Diese Einheit verfügt über mehr als einen Stromanschluß; um Strom gänzlich von der Einheit fernzuhalten, müssen alle Stromzufuhren abgetrennt sein.

Avvertenza Questa unità ha più di una connessione per alimentatore elettrico; tutte le connessioni devono essere completamente rimosse per togliere l'elettricità dall'unità.

Advarsel Denne enheten har mer enn én strømtilkobling. Alle tilkoblinger må kobles helt fra for å eliminere strøm fra enheten.

Aviso Este dispositivo possui mais do que uma conexão de fonte de alimentação de energia; para poder remover a fonte de alimentação de energia, deverão ser desconectadas todas as conexões existentes.

¡Atención! Esta unidad tiene más de una conexión de suministros de alimentación; para eliminar la alimentación por completo, deben desconectarse completamente todas las conexiones.

Warning! Denna enhet har mer än en strömförsörjningsanslutning; alla anslutningar måste vara helt avlägsnade innan strömtillförseln till enheten är fullständigt bruten.

TN Power Warning



WARNING: The device is designed to work with a TN power system.

Waarschuwing Het apparaat is ontworpen om te functioneren met TN energiesystemen.

Varoitus Koje on suunniteltu toimimaan TN-sähkövoimajärjestelmien yhteydessä.

Avertissement Ce dispositif a été conçu pour fonctionner avec des systèmes d'alimentation TN.

Warnung Das Gerät ist für die Verwendung mit TN-Stromsystemen ausgelegt.

Avvertenza Il dispositivo è stato progettato per l'uso con sistemi di alimentazione TN.

Advarsel Utstyret er utfomet til bruk med TN-strømsystemer.

Aviso O dispositivo foi criado para operar com sistemas de corrente TN.

¡Atención! El equipo está diseñado para trabajar con sistemas de alimentación tipo TN.

Warning! Enheten är konstruerad för användning tillsammans med elkraftssystem av TN-typ.

Action to Take After an Electrical Accident

If an electrical accident results in an injury, take the following actions in this order:

1. Use caution. Be aware of potentially hazardous conditions that could cause further injury.

2. Disconnect power from the device.
3. If possible, send another person to get medical aid. Otherwise, assess the condition of the victim, and then call for help.

Agency Approvals for ACX7100 Routers

IN THIS SECTION

- [Compliance Statement for Argentina | 188](#)

The ACX7100 routers comply with the following standards:

- Safety
 - CAN/CSA-C22.2 No. 60950-1 Information Technology Equipment - Safety
 - UL 60950-1 (2nd Edition) Information Technology Equipment - Safety
 - EN 60950-1: 2006/A2:2013 Information Technology Equipment - Safety
 - IEC 60950-1: 2005/A2:2013 Information Technology Equipment - Safety (All country deviations): CB Scheme
 - CAN/CSA-C22.2 No. 62368-1-14 Information Technology Equipment - Safety
 - UL 62368-1 Information Technology Equipment - Safety
 - EN 62368-1: 2014 Information Technology Equipment - Safety
 - IEC 62368-1: 2014 2nd Edition Information Technology Equipment - Safety (All country deviations): CB Scheme
 - EN 60825-1 Safety of Laser Products - Part 1: Equipment classification and requirements
- EMC
 - EN 300 386 V1.6.1 Class A Telecom Network Equipment - EMC requirements
 - EN 300 386 V2.1.1 Class A Telecom Network Equipment - EMC requirements
 - FCC 47 CFR Part 15 Class A USA Radiated and Conducted Emissions

- EN 55032 Class A European Radiated and Conducted Emissions
- AS/NZS CISPR 32 Class A Australia/New Zealand Radiated and Conducted Emissions
- ICES-003 Class A Canada Radiated and Conducted Emissions
- VCCI- CISPR 32 Class A Japanese Radiated and Conducted Emissions
- BSMI CNS 13438 and NCC C6357 Taiwan Radiated and Conducted Emissions (at 10 meter)
- KN32 Korea Radiated and Conducted Emission (at 10 meter)
- TEC/EMI/TEL-001/FEB-09
- TEC-SD-DD-EMC-221-05-OCT-16
- Immunity
 - EN 300 386 V1.6.1 Class A Telecom Network Equipment – Immunity requirements
 - EN 300 386 V2.1.1 Class A Telecom Network Equipment - Immunity requirements
 - EN 55024 (CISPR 24)
 - IEC/EN 61000-4-X (-2, -3, -4, -5, -6, -11)
 - KN35 Korea Immunity
 - KN61000-4-X (-2, -3, -4, -5, -6, -11) Korea Immunity
 - TEC/EMI/TEL-001/FEB-09 India Immunity
 - TEC-SD-DD-EMC-221-05-OCT-16
 - IG Surge
 - EN 55035 (CISPR 35:2016) Electromagnetic compatibility of multimedia equipment
- NEBS
 - SR-3580 NEBS Criteria Levels (Level 3 Compliance)
 - GR-63-CORE: NEBS, Physical Protection
 - GR-1089-CORE: EMC and Electrical Safety for Network Telecommunications Equipment
 - Data Center DC 3160
- Energy Efficiency requirements
 - AT&T TEER (ATIS-06000015.03.2013)

- ECR 3.0.1
- ETSI ES 203 136 (2013-05)
- Verizon TEEER (VZ.TPR.9205 Issue 6)
- Amazon Customer Requirements

Compliance Statement for Argentina

EQUIPO DE USO IDÓNEO.

Compliance Statements for Data Center

- The equipment is suitable for installation as part of the Common Bonding Network (CBN).
- The equipment is suitable for installation in locations where the National Electrical Code (NEC) applies.
- The battery return connection is to be treated as an isolated DC return (that is, DC-I), as defined in GR-1089-CORE.
- You must provision a readily accessible device outside of the equipment to disconnect power. The device must also be rated based on local electrical code practice.

Compliance Statements for EMC Requirements

IN THIS SECTION

- [Canada | 189](#)
- [European Community | 189](#)
- [Israel | 189](#)
- [Japan | 189](#)

Canada

CAN ICES-3 (A)/NMB-3(A)

European Community

This is a Class A product. In a domestic environment, this product might cause radio interference in which case the user might be required to take adequate measures.

Israel

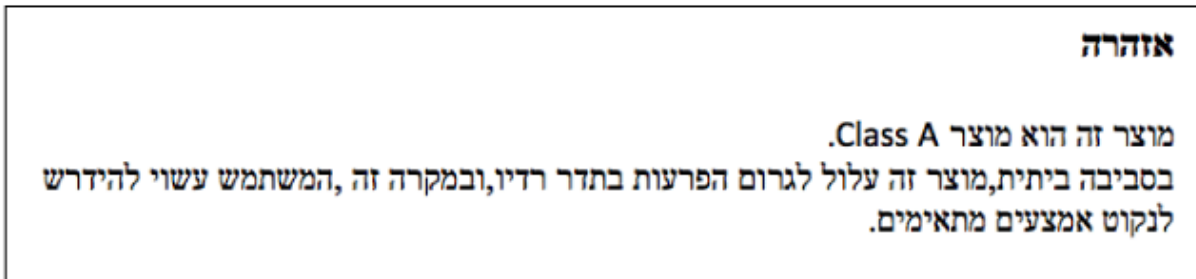

Translation from Hebrew—Warning: This product is Class A. In residential environments, the product might cause radio interference, and in such a situation, the user might be required to take adequate measures.

Japan

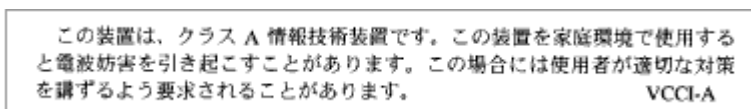

The preceding translates as follows:

This is a Class A product based on the standard of the Voluntary Control Council for Interference by Information Technology Equipment (VCCI). If this product is used near a radio or television receiver in a domestic environment, it might cause radio interference. Install and use the equipment according to the instruction manual. VCCI-A.

United States

The hardware equipment has been tested and found to comply with the limits for a Class A digital device, pursuant to Part 15 of the FCC Rules. These limits are designed to provide reasonable protection against harmful interference when the equipment is operated in a commercial environment. This equipment generates, uses, and can radiate radio frequency energy and, if not installed and used in accordance with the instruction manual, might cause harmful interference to radio communications. Operation of this equipment in a residential area is likely to cause harmful interference in which case the user will be required to correct the interference at his own expense.

Compliance Statements for Environmental Requirements

Batteries in this product are not based on mercury, lead, or cadmium substances. The batteries used in this product are in compliance with EU Directives 91/157/EEC, 93/86/EEC, and 98/101/EEC. The product documentation includes instructional information about the proper method of reclamation and recycling.