

EX4100-F Switch Hardware Guide

Published
2024-05-28

Juniper Networks, Inc.
1133 Innovation Way
Sunnyvale, California 94089
USA
408-745-2000
www.juniper.net

Juniper Networks, the Juniper Networks logo, Juniper, and Junos are registered trademarks of Juniper Networks, Inc. in the United States and other countries. All other trademarks, service marks, registered marks, or registered service marks are the property of their respective owners.

Juniper Networks assumes no responsibility for any inaccuracies in this document. Juniper Networks reserves the right to change, modify, transfer, or otherwise revise this publication without notice.

EX4100-F Switch Hardware Guide

Copyright © 2024 Juniper Networks, Inc. All rights reserved.

The information in this document is current as of the date on the title page.

YEAR 2000 NOTICE

Juniper Networks hardware and software products are Year 2000 compliant. Junos OS has no known time-related limitations through the year 2038. However, the NTP application is known to have some difficulty in the year 2036.

END USER LICENSE AGREEMENT

The Juniper Networks product that is the subject of this technical documentation consists of (or is intended for use with) Juniper Networks software. Use of such software is subject to the terms and conditions of the End User License Agreement ("EULA") posted at <https://support.juniper.net/support/eula/>. By downloading, installing or using such software, you agree to the terms and conditions of that EULA.

Table of Contents

About This Guide | ix

1

Fast Track: Initial Installation

Fast Track to Rack Installation and Power | 2

Install the EX4100-F Switch | 2

Connect to Power | 5

Claim, Onboard, and Configure EX4100-F | 9

2

System Overview and Specifications

EX4100-F System Overview | 12

EX4100-F Switches Hardware Overview | 12

EX4100-F Models and Specifications | 19

EX4100-F Chassis | 35

Chassis Physical Specifications for EX4100-F Switches | 36

Chassis Status LEDs on EX4100-F Switches | 42

LEDs on the Management Port on EX4100-F Switches | 44

LEDs on the RJ-45 Network Ports, Virtual Chassis Ports, and Uplink Ports on EX4100-F Switches | 46

Cooling System and Airflow in an EX4100-F Switch | 50

EX4100-F Power System | 56

AC Power Supply in EX4100-F Switches | 56

3

Site Planning and Preparation

Site Preparation Checklist for EX4100-F Switches | 64

EX4100-F Site Guidelines and Requirements | 66

Environmental Requirements and Specifications for EX4100-F Switches | 67

General Site Guidelines | 68

Site Electrical Wiring Guidelines | 68

Rack Requirements | 69

Cabinet Requirements for EX4100-F Switches | 71

Clearance Requirements for Airflow and Hardware Maintenance for EX4100-F Switches | 72

EX4100-F Network Cable and Transceiver Planning | 78

Pluggable Transceivers and Cables Supported on EX4100-F Switches | 78

SFP+ Direct Attach Copper Cables for EX Series Switches | 79

Overview of EX Series Switches: Fiber-Optic Cable Signal Loss, Attenuation, and Dispersion | 81

Calculate the Fiber-Optic Cable Power Budget for EX Series Devices | 83

Calculating the Fiber-Optic Cable Power Margin for EX Series Devices | 84

EX4100-F Management Cable Specifications and Pinouts | 86

Management Cable Specifications | 86

Console Port Connector Pinout Information | 87

USB Port Specifications for an EX Series Switch | 88

RJ-45 Management Port Connector Pinout Information | 89

RJ-45 Port, SFP Port, and SFP+ Port Connector Pinouts | 90

RJ-45 to DB-9 Serial Port Adapter Pinout Information | 94

4

Initial Installation and Configuration

Install the EX4100-F Switch | 96

Unpack the EX4100-F Switch | 97

Packing List for an EX4100-F Switch | 97

Register Products—Mandatory to Validate SLAs | 99

Mount an EX4100-F Switch on Two Posts in a Rack or Cabinet | 100

Mount an EX4100-F Switch on Four Posts in a Rack or Cabinet | 102

Mount an EX4100-F Switch in a Recessed Position in a Rack or Cabinet | 106

Mount an EX4100-F Switch on a Wall | 109

Mounting an EX4100-F-12P and EX4100-F-12T switch | **112**

Mounting an EX4100-F-12P and EX4100-F-12T Switch on a Desk | **113**

Mounting an EX4100-F-12P and EX4100-F-12T Switch Under a Desk or Other Level Surface | **114**

Mounting an EX4100-F-12P and EX4100-F-12T Switch on Two Posts of a Rack | **118**

Mounting an EX4100-F-12P and EX4100-F-12T Switch on a Wall | **121**

Mounting an EX4100-F-12P and EX4100-F-12T Switch on a Ferrous Wall using Magnet Pads | **125**

Mounting an EX4100-12P and EX4100-12T Switch on a DIN Rail | **129**

Unmounting an EX4100-F-12P and EX4100-F-12T Switch From a DIN Rail | **132**

Common Instructions for EX4100-F-12P and EX4100-F-12T Mounting Options | **134**

Attaching the Power Adaptor to the Power Adaptor Tray | **135**

Attaching the Power Adaptor Tray to the Switch Chassis | **137**

Attaching the Cable Guard to Protect Cable Connections | **137**

Attaching the Standard Cable Lock to the Security Slot of the Switch | **139**

Connect the EX4100-F to Power | 139

Connect Earth Ground to an EX4100-F Switch | **140**

Connect AC Power to an EX4100-F Switch | **142**

Connect AC power to an EX4100-F-12P and EX4100-F-12T Switch | **145**

Connect the EX4100-F Switch to External Devices | 147

Connect a Device to a Network for Out-of-Band Management | **147**

Connect a Device to a Management Console Using an RJ-45 Connector | **148**

Connect an EX4100-F Switch to a Management Console Using the USB Type-C Console Port | **150**

Connect the EX4100-F Switch to the Network | 151

Install a Transceiver | **152**

Connect a Fiber-Optic Cable | **155**

Configure Junos OS on an EX4100-F Switch | 156

EX4100-F Default Configuration | **156**

Connect and Configure an EX4100-F Switch | 172

Revert to the Default Factory Configuration on an EX Series Switch | 178

Revert to the EX Series Switch Factory-Default Configuration Using the request system zeroize Command | 179

Revert to the EX Series Switch Factory-Default Configuration Using the load factory-default Command | 179

Revert to the Factory-Default Configuration Using the Factory Reset/Port Mode button | 180

5

Maintain Components

Maintain Transceivers | 183

Remove a Transceiver | 183

Install a Transceiver | 185

Maintain Fiber-Optic Cables | 189

Connect a Fiber-Optic Cable | 189

Disconnect a Fiber-Optic Cable | 190

How to Handle Fiber-Optic Cables | 191

6

Troubleshoot Hardware

Troubleshoot the EX4100-F Components | 194

Chassis Component Alarm Conditions on EX4100-F Switches | 194

Troubleshoot Temperature Alarms in EX Series Switches | 197

7

Contact Customer Support and Return the Chassis or Components

Contacting Customer Support | 205

Return an EX4100-F Chassis | 206

How to Return an EX4100-F Switch for Repair or Replacement | 206

Locate the Serial Number on an EX4100-F Switch | 207

List the Switch and Components Details with the CLI | 208

Locate the Chassis Serial Number ID Label on an EX4100-F Switch | 213

Contact Customer Support to Obtain a Return Material Authorization | 214

Pack an EX4100-F Switch for Shipping | 215

Pack an EX4100-F Switch for Shipping | 215

Safety and Compliance Information

Safety Information for EX4100-F | 220

General Safety Guidelines and Warnings | 220

Definitions of Safety Warning Levels | 221

Qualified Personnel Warning | 223

Warning Statement for Norway and Sweden | 224

Fire Safety Requirements | 224

Installation Instructions Warning | 225

Chassis and Component Lifting Guidelines | 226

Restricted Access Warning | 227

Ramp Warning | 228

Rack-Mounting and Cabinet-Mounting Warnings | 229

Grounded Equipment Warning | 233

Radiation from Open Port Apertures Warning | 233

Laser and LED Safety Guidelines and Warnings | 234

Maintenance and Operational Safety Guidelines and Warnings | 237

General Electrical Safety Guidelines and Warnings | 243

Action to Take After an Electrical Accident | 245

Prevention of Electrostatic Discharge Damage | 245

AC Power Electrical Safety Guidelines | 247

AC Power Disconnection Warning | 248

DC Power Electrical Safety Guidelines | 249

DC Power Disconnection Warning | 250

DC Power Grounding Requirements and Warning | 251

DC Power Wiring Sequence Warning | 252

DC Power Wiring Terminations Warning | 254

Multiple Power Supplies Disconnection Warning | 255

TN Power Warning | 256

Agency Approvals for EX Series Switches | 257

Compliance Statements for EMC Requirements for EX Series Switches | 258

Compliance Statements for Acoustic Noise for EX Series Switches | 262

Statements of Volatility for Juniper Network Devices | 262

About This Guide

Use this guide to install hardware and perform initial software configuration, routine maintenance, and troubleshooting for the EX4100-F switch. After completing the installation and basic configuration procedures covered in this guide, refer to the Junos OS documentation for information about further software configuration.

1

CHAPTER

Fast Track: Initial Installation

[Fast Track to Rack Installation and Power](#) | 2

[Claim, Onboard, and Configure EX4100-F](#) | 9

Fast Track to Rack Installation and Power

SUMMARY

This procedure guides you through the simplest steps for the most common installation to get your EX4100-F switch in a rack and connect it to power.

Have more complex installation needs? See ["Install the EX4100-F Switch" on page 96](#)

IN THIS SECTION

- [Install the EX4100-F Switch | 2](#)
- [Connect to Power | 5](#)

Install the EX4100-F Switch

IN THIS SECTION

- [Install the EX4100-F Switch on a Rack | 2](#)
- [Install the EX4100-F-12P and EX4100-F-12T Switch on a Desk | 4](#)
- [What's in the Box? | 4](#)
- [What Else Do I Need? | 5](#)

Install the EX4100-F Switch on a Rack

The mounting kit that ships in the box has the brackets you need to install the switch in a two-post rack. We'll walk you through how to install the switch in a two-post rack. The following are instructions on how to install the EX4100-F switch models with built-fans/power supplies in a rack (EX4100-F-24T, EX4100-F-24P, EX4100-F-48P, and EX4100-F-48T).

Before you install, review the following. Also, have someone available to help you secure the switch to the rack.

- ["EX4100-F Site Guidelines and Requirements" on page 66.](#)
- [General Safety Guidelines and Warnings.](#)
- ["Packing List for an EX4100-F Switch" on page 97.](#)

1. Place the switch on a flat, stable surface.

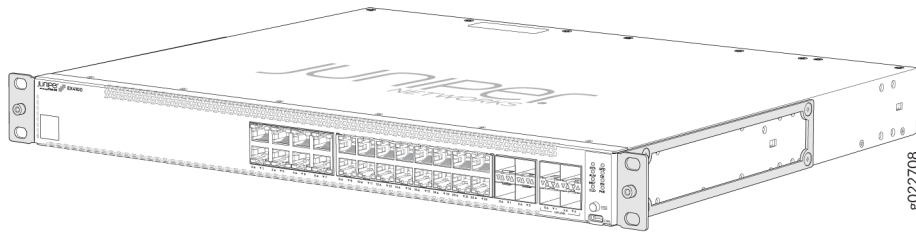

2. Wrap and fasten one end of the ESD grounding strap around your bare wrist, and connect the other end to a site ESD point.
3. Lift the switch and position it in the rack. Position the switch so that the AIR IN labels on the fan modules are facing the cold aisle or the AIR OUT labels on the fan modules are facing the hot aisle. Line up the bottom hole in each mounting bracket with a hole in each rack post, ensuring that the switch is level.

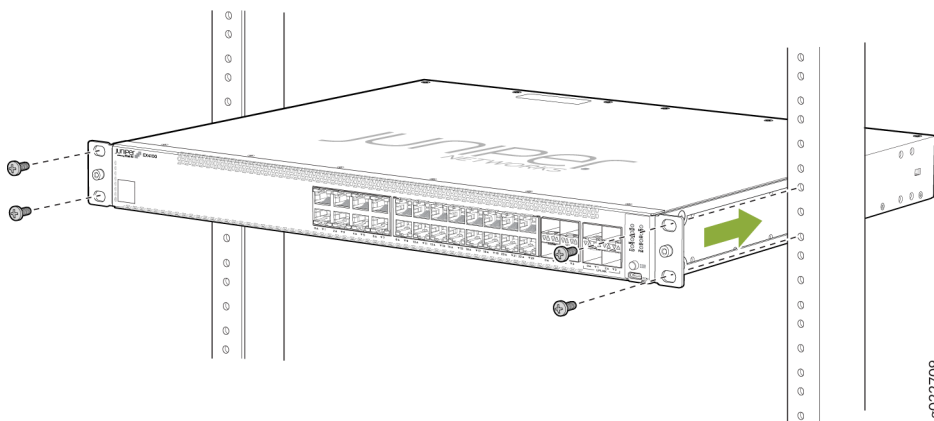

4. While you're holding the switch in place, have a second person insert and tighten the rack mount screws to secure the mounting brackets to the rack posts. Tighten the screws in the two bottom holes first, and then tighten the screws in the two top holes.
5. Check that the mounting brackets on each side of the rack are lined up with each other.

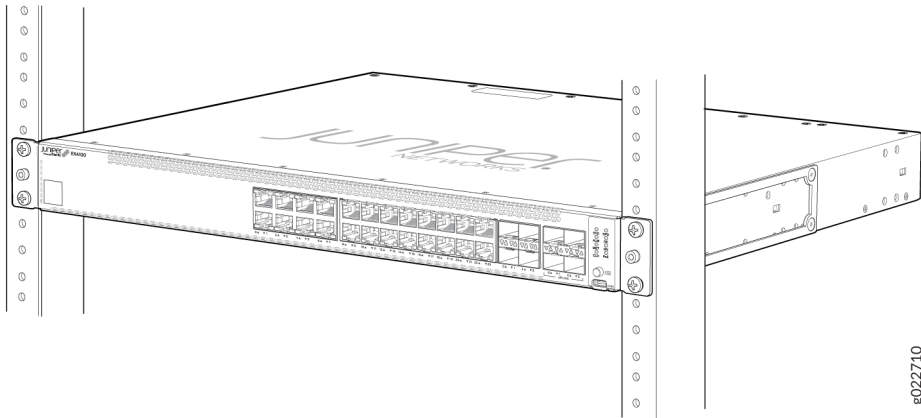

6. Cover the empty extension module and the power supply slots by using the covers that came with the switch.

Install the EX4100-F-12P and EX4100-F-12T Switch on a Desk

The following are instructions on how to install the EX4100-F-12P and EX4100-F-12T switches that use an external power supply adapter.

1. Place the switch and its adapter on the desk or the level surface. The following image shows an EX4100-F-12P switch mounted on a desk. The same procedure applies to an EX4100-F-12T switch as well.

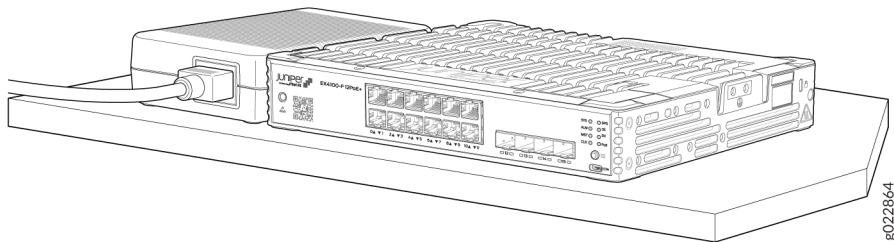

2. Ensure that the switch rests firmly on the desk or level surface.

What's in the Box?

- EX4100-F switch with built-in fans and power supplies or EX4100-F fanless switch that uses an external power supply adaptor.
- Two 2-post mounting brackets for EX4100-F-24P, EX4100-F-48P, EX4100-F-24T, EX4100-F-48T switches.

- One AC power cord appropriate for your geographical location.
- AC power cord retainer (not provided for EX4100-F-12P and EX4100-F-12T switches)
- Eight preinstalled dust covers for SFP ports (four for EX4100-F-12P and EX4100-F-12T switches)
- Four rubber feet (not required for EX4100-F-12P and EX4100-F-12T switches)
- RJ-45 cable and RJ-45 to DB-9 serial port adapter

What Else Do I Need?

- Someone to help you secure the switch to the rack
- Mounting screws to secure the EX4100, EX4100-F-24P, EX4100-F-24T, EX4100-F-48P, and EX4100-F-48T switches to the rack
- A number two Phillips (+) screwdriver
- A serial-to-USB adapter (if your laptop doesn't have a serial port)
- An electrostatic discharge (ESD) grounding strap
- A management host such as a laptop or desktop PC
- Two M5X10mm screws with washers to secure the grounding lug (two 10-32 screws for EX4100-F-12P and EX4100-F-12T switches)
- A grounding cable: 8 AWG (2 mm²), minimum 90° C wire, or as permitted by the local code, with a Panduit LCD8-14A-L or equivalent lug attached (LCD8-10A-L for EX4100-F-12P and EX4100-F-12T switches)

Connect to Power

IN THIS SECTION

- [Ground the Switch | 6](#)
- [Connect AC Power to an EX4100-F Switch | 7](#)
- [Connect AC power to an EX4100-F-12P and EX4100-F-12T Switch | 8](#)

To connect the EX4100 switch to AC power, you must do the following:

Ground the Switch

To ground the EX4100-F switch, do the following:

1. Connect one end of the grounding cable to a proper earth ground, such as the rack in which the switch is mounted.
2. Place the grounding lug attached to the grounding cable over the protective earthing terminal on the rear panel.

Connect a Grounding Cable to an EX4100-F-24P, EX4100-F-24T, EX4100-F-48P, and EX4100-F-48T Switch

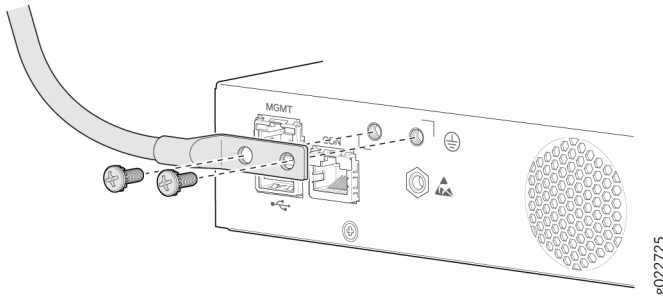

Connect a Grounding Cable to an EX4100-F-12P and EX4100-F-12T Switch

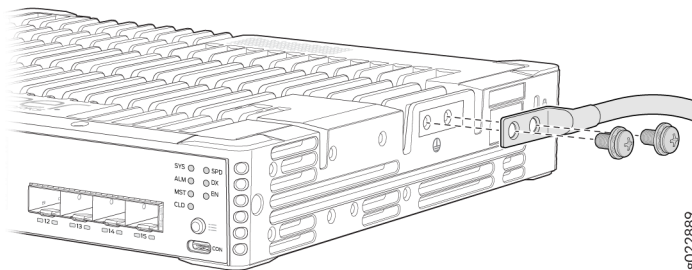

3. Secure the grounding lug to the protective earthing terminal with the screws.
4. Secure the grounding cable and ensure that it does not touch or block access to other switch components.

Connect AC Power to an EX4100-F Switch

For information about the supported AC power cord specifications, see ["EX4100-F Power System" on page 56](#).

To connect AC power to an EX4100-F-24P, EX4100-F-24T, EX4100-F-48P, and EX4100-F-48T Switch:

1. Push the power cord into the slot in the adjustment nut of the power cord retainer clip. Turn the nut until it is tight against the base of the coupler and the slot in the nut is turned 90° from the top of the switch.
2. If the AC power source outlet has a power switch, set it to the OFF (O) position.
3. Insert the power cord plug into an AC power source outlet.
4. If the AC power source outlet has a power switch, set it to the ON (I) position.

Fitting an Adjustment Nut to the AC Power Cord Retainer Clip on EX4100-F-24P, EX4100-F-24T, EX4100-F-48P, and EX4100-F-48T switches

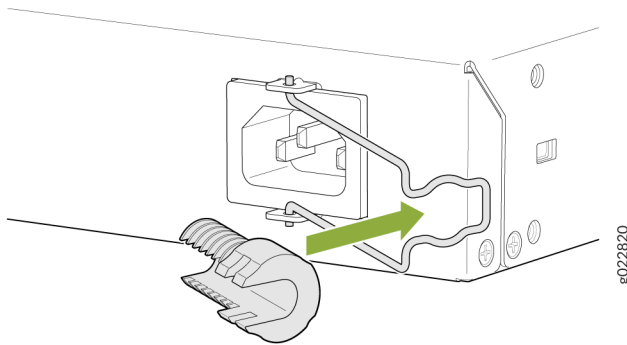

Connecting an AC Power Cord to the AC Power Cord Inlet on EX4100-F-24P, EX4100-F-24T, EX4100-F-48P, and EX4100-F-48T switches

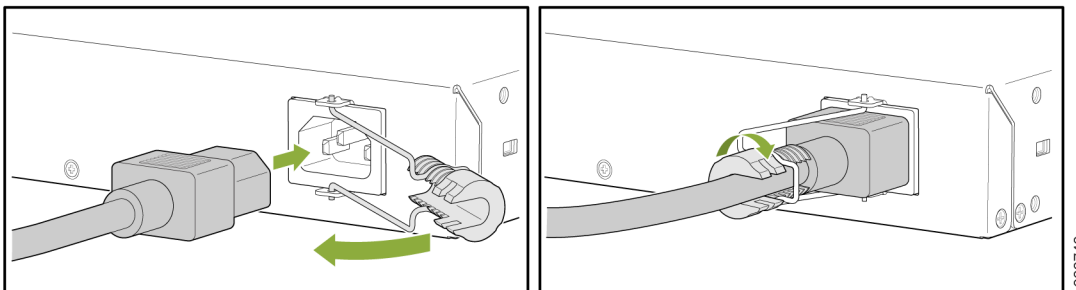

Connect AC power to an EX4100-F-12P and EX4100-F-12T Switch

For information about the supported AC power cord specifications, see ["EX4100-F Power System" on page 56](#).

To connect AC power to an EX4100-F-12P and EX4100-F-12T Switch:

1. Push the end of the power cord retainer strip into the slot beside the power cord inlet until the strip snaps into place.
2. Press the small tab on the retainer strip to loosen the loop. Slide the loop until you have enough space to insert the power cord coupler into the power cord inlet.
3. Locate the power cord or cords shipped with the switch. The cords have plugs appropriate for your geographical location.
4. Insert the power cord coupler firmly into the power cord inlet of the power supply adaptor.

Connecting an AC Power Cord Retainer Clip to the AC Power Cord Inlet of an EX4100-F-12P and EX4100-F-12T Switch

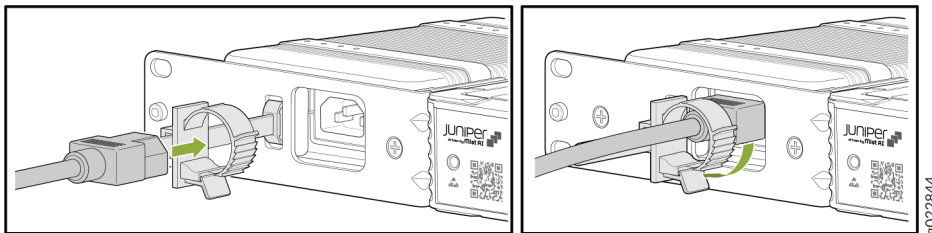

5. Slide the loop toward the power supply until it is snug against the base of the coupler.
6. Press the tab on the loop and draw out the loop into a tight circle.
7. Insert the power cord that is permanently attached to the power supply adaptor, to the DC inlet of the switch.
8. Switch off the AC power source outlet.
9. Insert the power cord plug of the power cord that was attached to the power inlet of the power supply adaptor, into the AC power source outlet.
10. Switch on the AC power source outlet.

Figure 1: Connect Power Supply Adaptor to DC Inlet of the EX4100-F-12P Switch

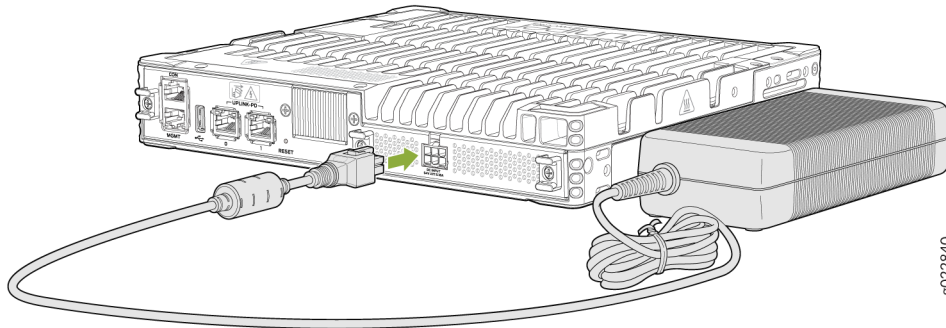
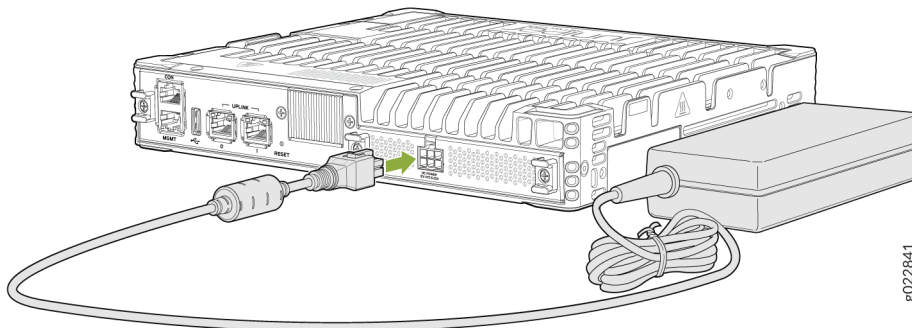

Figure 2: Connect Power Supply Adaptor to DC Inlet of the EX4100-F-12T Switch



Claim, Onboard, and Configure EX4100-F

SUMMARY

This topic provides you the pointers to onboard and configure the EX4100-F switches using Mist, or configure the EX4100-F switches using Junos CLI.

EX4100-F switch is a cloud-ready switch, and you can manage this switch using [Mist AI cloud portal](#). If you have a Mist Wired Assurance license, you can follow a few simple steps to get an EX4100-F up and running in the Juniper Mist AI cloud portal. See [Table 1 on page 10](#) for more information.

Table 1: Onboard and Configure EX4100-F Using Mist

If you want to	Then
Claim and Onboard to Mist	See Cloud-Ready EX and QFX Switches with Mist
Configure Wired Assurance	See Juniper Mist Wired Configuration Guide
See all documentation available for Wired Assurance	Visit Wired Assurance Documentation

If you do not have a Mist Wired Assurance license, you can configure EX4100-F using Junos CLI. See [Table 2 on page 10](#) for more information.

Table 2: Configure EX4100-F Using Junos CLI

If you want to	Then
Customize basic configuration	See "Configure Junos OS on an EX4100-F Switch" on page 156
Explore the software features supported on EX4100-F	See Feature Explorer
Configure Junos features on EX4100-F	See User Guides

2

CHAPTER

System Overview and Specifications

[EX4100-F System Overview | 12](#)

[EX4100-F Models and Specifications | 19](#)

[EX4100-F Chassis | 35](#)

[Cooling System and Airflow in an EX4100-F Switch | 50](#)

[EX4100-F Power System | 56](#)

EX4100-F System Overview

IN THIS SECTION

- [EX4100-F Switches Hardware Overview | 12](#)

EX4100-F Switches Hardware Overview

IN THIS SECTION

- [EX4100-F Switch Models | 13](#)
- [Virtual Chassis | 14](#)
- [Power over Ethernet Ports | 14](#)
- [Powered Device | 15](#)
- [EX4100-F Cooling System | 15](#)
- [EX4100-F Power System | 16](#)
- [Mounting Options for EX4100-F Switches | 16](#)
- [Uplink Ports | 19](#)

The EX4100-F are suitable for small, medium, and large campus and branch enterprise deployments. You can use the switch models in high, medium, or low-density environments, because these models offer flexibility in terms of architecture and capabilities.

EX4100-F (fixed-form) switch models are:

Fanless models using external power supply adaptors

- EX4100-F-12T and EX4100-F-12P

Models with built-in fans and power supplies

- EX4100-F-24T, EX4100-F-24P, EX4100-F-48P, and EX4100-F-48T

You can manage EX4100-F switches from the cloud and on premise. The switches allow for simple, efficient, and scalable network management using cloud-based hosted management applications, on-premise management tools, and APIs.

Because EX4100-F switch models support Layer 2 (L2) and Layer 3 (L3) technologies, you can deploy them anywhere: core, distribution, or access layer. This aspect of the switch models also allows for a network overlay that provides uniform multisite connectivity.

You can manage EX4100-F switches from the CLI.

Compact solution—The EX4100-F family of switches are single-rack unit devices. They are ideal solutions for crowded wiring closets and access switch locations such as data centers, campuses, and branch offices. They provide carrier-class reliability of modular systems with the economics and flexibility of stackable platforms.

Virtual Chassis—EX4100-F switches support Virtual Chassis technology. You can interconnect up to 10 EX4100 and/or EX4100-F switches to form a Virtual Chassis.

High availability—EX4100-F switches provide high availability through redundant power supplies and fans, graceful Routing Engine switchover (GRES), and nonstop bridging and routing when deployed in a Virtual Chassis configuration.

Mist Cloud managed—EX4100-F switches are built to be cloud native. You can manage activities and features such as onboarding, fast bootup, streaming telemetry, and fast changes (JET) from the Mist cloud. Even though the EX4100-F switches are built specifically for management in the Mist cloud, you can manage them on premise if you prefer.

EVPN VXLAN—EX4100-F switch models can act as L2 and L3 VXLAN gateways to support a mix of legacy endpoints and newer devices. In combination with VXLAN, EVPN provides the capability to connect a multi-site enterprise customer network in an open and standards-based manner.

Multigigabit—Newer wave 2 and 802.11ax access points can use higher interface speeds on network switches to support higher scale and bandwidth for users and applications.

EX4100-F Switch Models

The following are the EX4100-F switch models.

Table 3: EX4100-F Switch Models

Fanless models using external power supply adaptors	Models with built-in fans and power supplies
"EX4100-F-12T" on page 23	"EX4100-F-24T" on page 28
"EX4100-F-12P" on page 20	"EX4100-F-24P" on page 25
	"EX4100-F-48P" on page 30
	"EX4100-F-48T" on page 33

Virtual Chassis

EX4100-F switches have dedicated Virtual Chassis ports (VCPs) that you can use to interconnect member switches of a Virtual Chassis. Only homogenous virtual chassis is supported; that is, you can connect any EX4100-F switch, including EX4100 gigabit and EX4100-F multigigabit switches, in a virtual chassis. You can interconnect a maximum of 10 switches to form a Virtual Chassis. You can operate these interconnected switches as a single, logical device with a single IP address. If you operate the interconnected switches as a single device, you must use all the Virtual Chassis ports as Virtual Chassis ports or use all of them as network ports. You cannot mix multiple types of ports within a single, logical device.

For more information about Virtual Chassis, see [Understanding EX Series Virtual Chassis](#).

Power over Ethernet Ports

EX4100-F switches are available with or without Power over Ethernet (PoE) or Power over Ethernet Plus (PoE+/PoE++) capability. Models that support PoE, PoE+, or PoE++ provide that support on all of their RJ-45 downlink ports. The switch models provide perpetual and fast PoE functionality. PoE, PoE+, and PoE++ ports provide electrical current to devices—such as IP phones, wireless access points, and security cameras—through network cables. Because the network cables provide electrical current, you do not need separate power cords for those devices.

1. The EX4100-F-24P and EX4100-F-48P switch models support PoE+ (30 W) by default.
2. The EX4100-F-12P switch model supports PoE+ (30 W) by default.

For more information about PoE support on EX series switches, see [Understanding PoE on EX Series Switches](#).

NOTE: IEEE 802.3at class 4 powered devices require category 5 or higher Ethernet cables.

Powered Device

The powered device (PD) feature of EX4100-F-12P allows the switch to be powered by another PoE switch which supports 802.3bt (ex: EX4400 PoE switches or EX4100-24MP/48MP). It is done by connecting one or two of the two 1/2.5/5/10 Gbps Base-T uplink ports on the rear panel of a EX4100-F-12P switch to the downlink ports on the front panel of the power-providing switch. The EX4100-F-12P switch can also use AC power source whilst being powered by another switch.

Figure 3: EX4100-F-12P switch connected as a powered device

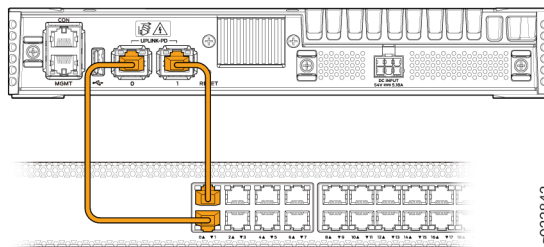

In addition to being able to draw power to power itself, the EX4100-F-12P switch can also power other devices because it has PoE+ enabled ports. The amount of power available to the switch to be able to power other devices is dependent on some factors. Because the switch only consumes 60W, any additional power supplied to it is available to the switch to power other devices. In [Table 28 on page 59](#), the PoE budget details of the switch are described. The PoE budget of EX4100-F-12P varies depending on whether it is connected to:

- Only the AC power source via the 280w power supply adaptor
- AC power source and a PoE++ PSE (power supply equipment) as a powered device via any one of the two 1/2.5/5/10G base T uplink ports on the rear panel
- AC power source and a PoE++ PSE as a powered device via both the 1/2.5/5/10G base T uplink ports on the rear panel

EX4100-F Cooling System

EX4100-F-24P, EX4100-F-24T, EX4100-F-48P, and EX4100-F-48T switch models have built-in fans. EX4100-F-12P and EX4100-F-12T are fanless switch models that have natural convection cooling. The

airflow direction depends on the fan modules and power supplies installed in the switch. You can order an EX4100-F switch that supports front-to-back airflow or back-to-front airflow, as follows:

- Front-to-back airflow: Air enters through the front of the switch.
- Back-to-front airflow: Air enters through the back of the switch.

The fan modules are hot-removable and hot-insertable field-replaceable units (FRUs) installed in the rear panel of the switch. You can remove and replace the FRUs without powering off the switch or disrupting switch functions.

EX4100-F Power System

The following list presents the EX4100-F switch models with their compatible power systems:

- EX4100-F-12P doesn't have PSU FRUs or built-in power supplies. It uses an external 280W power adapter.
- EX4100-F-12T doesn't have PSU FRUs or built-in power supplies. It uses an external 75W power adapter.
- EX4100-F-24P uses the built-in 450W AC power supply.
- EX4100-F-24T uses the built-in 65W AC power.
- EX4100-F-48P uses the built-in 850W AC power supply.
- EX4100-F-48T uses the built-in 90W AC power supply.



CAUTION: Avoid mixing:

- AC and DC power supplies in the same chassis.
- Power supplies with different airflow directions in the same chassis.
- Fan modules with different airflow directions in the same chassis.
- Power supplies and fan modules with different airflow directions in the same chassis.

If you install power supplies or fan modules with different airflow directions, Junos OS raises an alarm.

Mounting Options for EX4100-F Switches

The following table summarizes the mounting options for EX4100-F switch models.

Table 4: Mounting Options for EX4100-F Switches

Mounting Kit	SKU no	Provided/ Orderable	Usage	Details	Supported Models
2-post rack mounting kit	SRX34X-RMK	Provided	2-post rack mounting		EX4100-F-24P, EX4100-F-24T, EX4100-F-48P, and EX4100-F-48T.
Adjustable 4-post rack-mount kit	EX-4PST-RMK	Orderable	4-post rack mounting		EX4100-F-12P and EX4100-F-12T can be mounted on 2-post rack OR on front posts of a 4-post rack using EX4100-F-12-RME / EX4100-F-12-RMK.
Wall mount kit	EX-WMK	Orderable	Wall mounting		EX4100-F-24P, EX4100-F-24T, EX4100-F-48P, and EX4100-F-48T.
Rack mount ears	EX4100-F-12-RME	Provided	2-post rack mounting	The rack mounting ears (EX4100-F-12-RME) are attached to the chassis, and then the whole unit is assembled to the rack. This kit has no power adaptor tray.	EX4100-F-12P and EX4100-F-12T

Table 4: Mounting Options for EX4100-F Switches (Continued)

Mounting Kit	SKU no	Provided/ Orderable	Usage	Details	Supported Models
Rack mount power adapter tray	EX4100-F-12- PAT	Orderable	Power adapter tray	Mounted along with EX4100- F-12-RME kit	EX4100-F-12P and EX4100- F-12T
2-post rack mounting kit	EX4100-F-12- RMK	Orderable	2-post rack mounting	2-post rack mounting kit with attached rack-mounting ears or front- mounting brackets and attached power adaptor tray. EX-F-12-RMK is for chassis where width is ~10 inch. This is specific to certain products only.	EX4100-F-12P and EX4100- F-12T
Wall mount kit	EX4100-F-12- WMK	Orderable	Wall mounting		EX4100-F-12P and EX4100- F-12T
Magnet mount kit	EX4100-F-12- MMK	Orderable	Magnet mounting		EX4100-F-12P and EX4100- F-12T
Din rail kit	EX4100-F-12- DRK	Orderable	Din Rail mounting		EX4100-F-12P and EX4100- F-12T

Table 4: Mounting Options for EX4100-F Switches (Continued)

Mounting Kit	SKU no	Provided/ Orderable	Usage	Details	Supported Models
Cable guard	EX4100-F-12- CGD	Orderable	All mounting options supported by EX4100-F-12	Optional	EX4100-F-12P and EX4100-F-12T

Uplink Ports

EX4100-F switches have autosensing uplink ports that you can use to connect an access switch to a distribution switch. The uplink ports on the front panel (rear panel on EX4100-F-12P and EX4100-F-12T switches) are configured as network ports by default. You cannot use the uplink ports as Virtual Chassis ports. The uplink ports on the front panel support 1-gigabit SFP transceivers and/or 10-gigabit SFP+ transceivers. You can use a combination of SFP and SFP+ transceivers. Uplink ports for EX4100-F-12P and EX4100-F-12T switches are located on the rear panel - these are 1/2.5/5/10 GE BASE-T RJ-45 uplink ports. On the EX4100-F-12P, these uplink ports can be used to power the device - see ["Powered Device" on page 15](#).

For a list of supported transceivers, see ["Pluggable Transceivers and Cables Supported on EX4100-F Switches" on page 78](#).

EX4100-F Models and Specifications

IN THIS SECTION

- [EX4100-F-12P | 20](#)
- [EX4100-F-12T | 23](#)
- [EX4100-F-24P | 25](#)
- [EX4100-F-24T | 28](#)
- [EX4100-F-48P | 30](#)
- [EX4100-F-48T | 33](#)

The EX4100-F (fixed-form) switch models have either built-in power supplies and fans or fanless models using external power supply adaptors.

Let's take a look at the different EX4100-F models and their specifications.

Table 5: EX4100-F Switch Models

Fanless models using external power supply adaptors	Models with built-in fans and power supplies
"EX4100-F-12P" on page 20	"EX4100-F-24P" on page 25
"EX4100-F-12T" on page 23	"EX4100-F-24T" on page 28
	"EX4100-F-48P" on page 30
	"EX4100-F-48T" on page 33

EX4100-F-12P

Components on the Front and Rear Panels of EX4100-F-12P Switches

[Figure 4 on page 20](#) shows the front view of an EX4100-F-12P switch.

Figure 4: Front View of the EX4100-F-12P Switch



[Figure 5 on page 21](#) shows the rear view of an EX4100-F-12P switch.

Figure 5: Rear View of the EX4100-F-12P Switch



Figure 6 on page 21 shows the components on the front panel of the EX4100-F-12P switch.

Figure 6: Components on the Front Panel of the EX4100-F-12P Switch

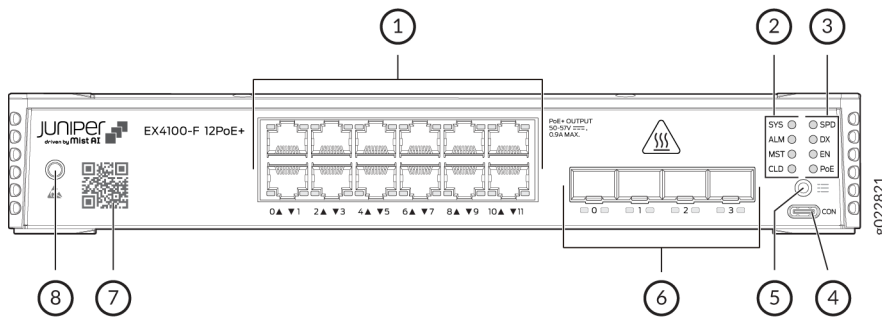

1– 10/100/1000BASE-T RJ-45 network ports. These ports in EX4100-F-12P switches support PoE+ (30W by default).	5– Factory Reset/Mode button
2– Chassis status LEDs (labeled SYS , ALM , MST , and CLD)	6– 10 GE SFP+ Virtual Chassis ports
3– Port mode LEDs (labeled SPD , DX , EN and PoE)	7– Claim Code label
4– RS232 to USB Type-C console port	8– Electrostatic discharge (ESD) point

Figure 7 on page 22 shows the components on the rear panel of the EX4100-F-12P switch.

Figure 7: Components on the Rear Panel of the EX4100-F-12P Switch

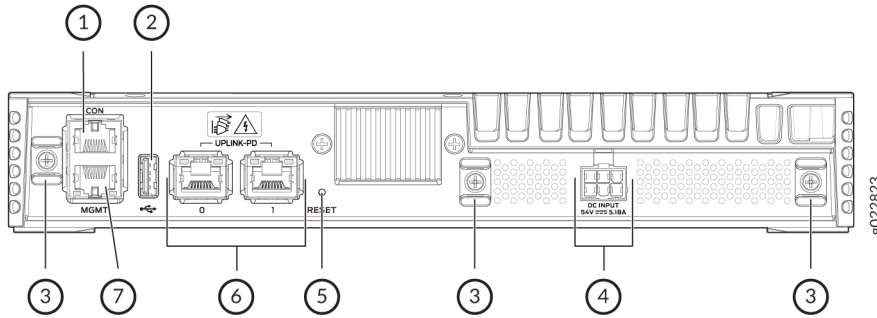

1– RJ-45 console port (labeled CON)	5– Reset button
2– USB 2.0 Type-A port	6– 1/2.5/5/10 GE BASE-T RJ-45 uplink ports
3– Cable Tie mount	7– RJ-45 management port (labeled MGMT)
4– DC power inlet	

Table 6 on page 22 lists the components shipped with EX4100-F-12P switch models.

Table 7 on page 22 describes the physical specifications and ports of EX4100-F-12P switches.

Table 6: EX4100-F-12P Switch Models, Shipped Components, and First Junos Release

Model Number	Fan Modules/Built-in Fans	Power Supply Units/Built-in power supply	First Junos OS Release
EX4100-F-12P	NA. Fanless models with natural convection cooling.	NA. Uses 280W external adapter.	22.3R1

Table 7: EX4100-F-12P Switches—Physical Specifications and Ports

Item	Description
Chassis Dimensions	Height - 1.75 in (4.44 cm) Depth - 9.66 in (24.54 cm)
Weight	3000g

Table 7: EX4100-F-12P Switches—Physical Specifications and Ports (Continued)

Item	Description
Built-in ports	<ul style="list-style-type: none"> • 12 1GbE Ethernet ports • 4 10GE SFP+ Virtual Chassis ports • 2 1/2.5/5/10GE BASE-T RJ-45 uplink ports
PoE ports	12 - PoE+ (30W by default)

EX4100-F-12T

Components on the Front and Rear Panels of EX4100-F-12T Switches

Figure 8 on page 23 shows the front view of an EX4100-F-12T switch.

Figure 8: Front View of the EX4100-F-12T Switch



Figure 9 on page 23 shows the rear view of an EX4100-F-12T switch.

Figure 9: Rear View of the EX4100-F-12T Switch



Figure 10 on page 24 shows the components on the front panel of the EX4100-F-12T switch.

Figure 10: Components on the Front Panel of the EX4100-F-12T Switch

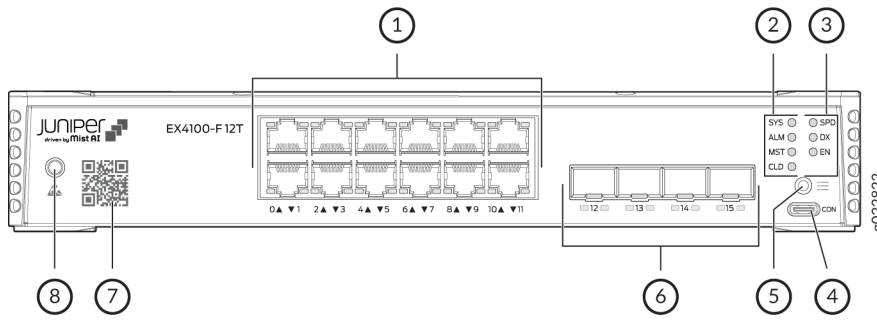

1– 10/100/1000BASE-T RJ-45 non-PoE network ports.	5– Factory Reset/Mode button
2– Chassis status LEDs (labeled SYS , ALM , MST , and CLD)	6– 10 GE SFP+ Virtual Chassis ports
3– Port mode LEDs (labeled SPD , DX , and EN)	7– Claim Code label
4– RS232 to USB Type-C console port	8– Electrostatic discharge (ESD) point

Figure 11 on page 24 shows the components on the rear panel of the EX4100-F-12T switch.

Figure 11: Components on the Rear Panel of the EX4100-F-12T Switch

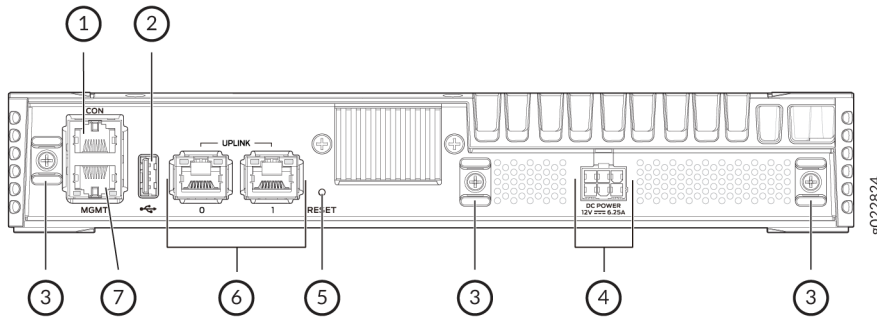

1– RJ-45 console port (labeled CON)	5– Reset button
2– USB 2.0 Type-A port	6– 1/2.5/5/10 GE BASE-T RJ-45 uplink ports
3– Cable Tie mount	7– RJ-45 management port (labeled MGMT)
4– DC power inlet	

Table 8 on page 25 lists the components shipped with EX4100-F-12T switch models.

Table 9 on page 25 describes the physical specifications and ports of EX4100-F-12T switches.

Table 8: EX4100-F-12T Switch Models, Shipped Components, and First Junos Release

Model Number	Fan Modules/Built-in Fans	Power Supply Units/Built-in power supply	First Junos OS Release
EX4100-F-12T	NA. Fanless models with natural convection cooling.	NA. Uses 75W external adapter.	22.3R1

Table 9: EX4100-F-12T Switches—Physical Specifications and Ports

Item	Description
Chassis Dimensions	Height - 1.75 in (4.44 cm) Depth - 9.66 in (24.54 cm)
Weight	2700g
Built-in ports	<ul style="list-style-type: none"> • 12 1GbE Ethernet ports • 4 10GE SFP+ Virtual Chassis ports • 2 1/2.5/5/10GE BASE-T RJ-45 uplink ports
PoE ports	0

EX4100-F-24P

Components on the Front and Rear Panels of EX4100-F-24P Switches

[Figure 12 on page 26](#) shows the front view of an EX4100-F-24P switch.

Figure 12: Front View of the EX4100-F-24P Switch



Figure 13 on page 26 shows the rear view of the EX4100-F-24P switch with 24 ports.

Figure 13: Rear View of the EX4100-F-24P Switch



Figure 14 on page 26 shows the components on the front panel of the EX4100-F-24P switch.

Figure 14: Components on the Front Panel of the EX4100-F-24P Switch

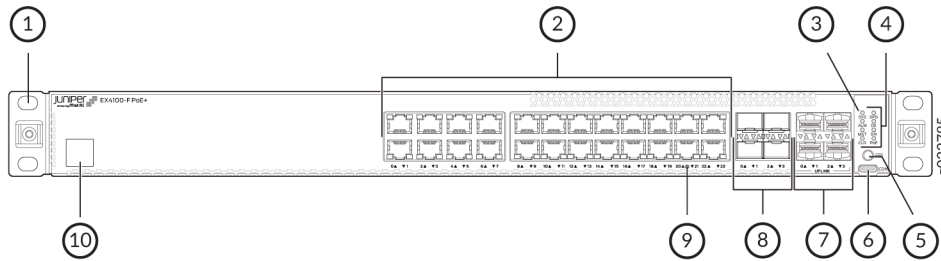

1– Front mounting brackets	6– RS232 to USB Type-C console port
2– 10/100/1000BASE-T RJ-45 network ports. These ports in EX4100-F-24P support PoE+ (30 W by default).	7– 10 GE SFP+ Uplink ports
3– Chassis status LEDs (labeled SYS , ALM , MST , and CLD)	8– 1/10 GE SFP+ Virtual Chassis ports
4– Port mode LEDs (labeled SPD , DX , EN and PoE)	9– Reset button
5– Factory Reset/Mode button	10– Claim Code label

Figure 15 on page 27 shows the components on the rear panel of EX4100-F-24P switch.

Figure 15: Components on the Rear Panel of EX4100-F-24P Switch

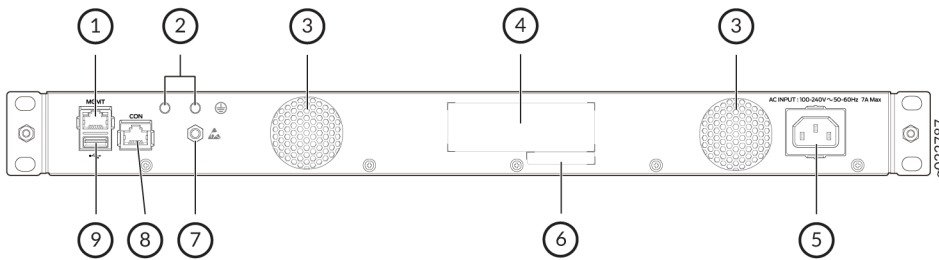

1– RJ-45 management port (labeled MGMT)	6– CLEI code label
2– Protective earthing terminal	7– Electrostatic discharge (ESD) point
3– Built-in fan modules	8– RJ-45 console port (labeled CON)
4– Serial number	9– USB 2.0 Type-A port
5– AC power supply socket	

Table 10 on page 27 lists the components shipped with EX4100-F-24P switch models.

Table 11 on page 27 describes the physical specifications and ports of EX4100-F-24P switches.

Table 10: EX4100-F-24P Switch Models, Shipped Components, and First Junos Release

Model Number	Built-in Fans	Built-in power supply	First Junos OS Release
EX4100-F-24P	Two built-in fan units with front-to-back airflow.	Built-in 450 W AC power supply	22.2R1

Table 11: EX4100-F-24P Switches—Physical Specifications and Ports

Item	Description
Chassis Dimensions	Height - 1.72 in (4.37 cm) Depth - 12.2 in (31.13 cm)
Weight	4745g

Table 11: EX4100-F-24P Switches—Physical Specifications and Ports (Continued)

Item	Description
Built-in ports	<ul style="list-style-type: none"> • 24 1GbE Ethernet ports. 4 1GbE/10GbE SFP+ Virtual Chassis ports. 4 10GE SFP+ uplink ports.
PoE ports	24 - PoE+ (30 W by default)

EX4100-F-24T

Components on the Front and Rear Panels of EX4100-F-24T Switches

Figure 16 on page 28 shows the front view of an EX4100-F-24T switch.

Figure 16: Front View of the EX4100-F-24T Switch



Figure 17 on page 28 shows the rear view of the EX4100-F-24T switch with 24 ports.

Figure 17: Rear View of the EX4100-F-24T Switch



Figure 18 on page 29 shows the components on the front panel of the EX4100-F-24T switch.

Figure 18: Components on the Front Panel of the EX4100-F-24T Switch

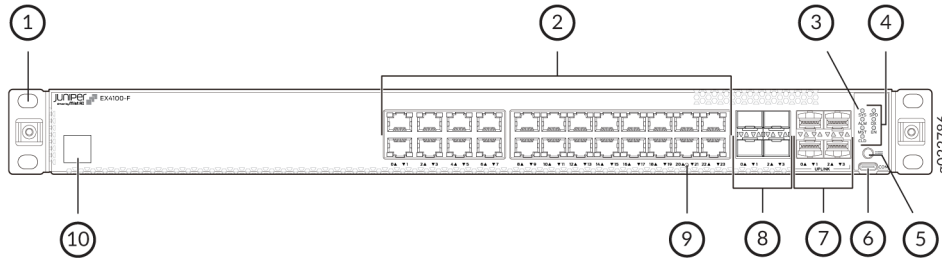

1– Front mounting brackets	6– RS232 to USB Type-C console port
2– 10/100/1000BASE-T RJ-45 non-PoE network ports.	7– 10 GE SFP+ Uplink ports
3– Chassis status LEDs (labeled SYS , ALM , MST , and CLD)	8– 1/10 GE SFP+ Virtual Chassis ports
4– Port mode LEDs (labeled SPD , DX , and EN)	9– Reset button
5– Factory Reset/Mode button	10– Claim Code label

Figure 19 on page 29 shows the components on the rear panel of EX4100-F-24T switch.

Figure 19: Components on the Rear Panel of EX4100-F-24T Switch

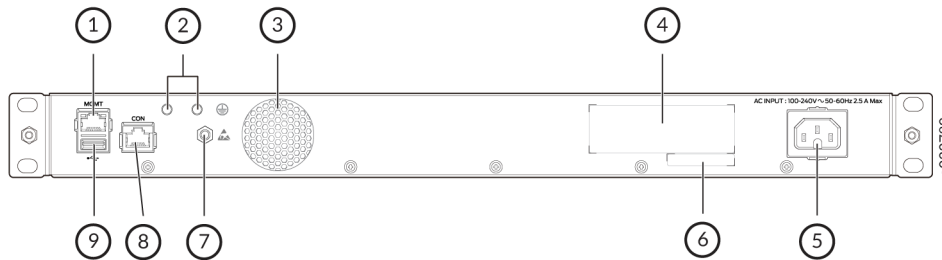

1– RJ-45 management port (labeled MGMT)	6– CLEI code label
2– Protective earthing terminal	7– Electrostatic discharge (ESD) point
3– Built-in fan module	8– RJ-45 console port (labeled CON)
4– Serial number	9– USB 2.0 Type-A port
5– AC power supply socket	

Table 12 on page 30 lists the components shipped with EX4100-F-24T switch models.

Table 13 on page 30 describes the physical specifications and ports of EX4100-F-24T switches.

Table 12: EX4100-F-24T Switch Models, Shipped Components, and First Junos Release

Model Number	Built-in Fans	Built-in power supply	First Junos OS Release
EX4100-F-24T	One built-in fan with front-to-back airflow	Built-in 65 W AC power supply	22.2R1

Table 13: EX4100-F-24T Switches—Physical Specifications and Ports

Item	Description
Chassis Dimensions	Height - 1.72 in (4.37 cm) Depth - 10.1 in (25.65 cm)
Weight	3520g
Built-in ports	<ul style="list-style-type: none"> • 24 1GbE Ethernet ports • 4 1GbE/10GbE SFP+ Virtual Chassis ports • 4 10GE SFP+ uplink ports
PoE ports	0

EX4100-F-48P

Components on the Front and Rear Panels of EX4100-F-48P Switches

[Figure 20 on page 31](#) shows the front view of an EX4100-F-48P switch.

Figure 20: Front View of the EX4100-F-48P Switch



Figure 21 on page 31 shows the rear view of the EX4100-F-48P switch with 48 ports.

Figure 21: Rear View of the EX4100-F-48P Switch



Figure 22 on page 31 shows the components on the front panel of the EX4100-F-48P switch.

Figure 22: Components on the Front Panel of the EX4100-F-48P Switch

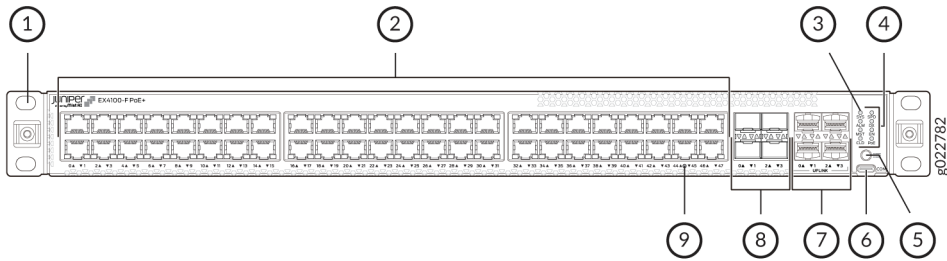

1– Front mounting brackets	6– RS232 to USB Type-C console port
2– 10/100/1000BASE-T RJ-45 network ports. These ports support in EX4100-F-48P support PoE+ (30 W by default).	7– 10 GE SFP+ Uplink ports
3– Chassis status LEDs (labeled SYS , ALM , MST , and CLD)	8– 1/10 GE SFP+ Virtual Chassis ports
4– Port mode LEDs (labeled SPD , DX , EN and PoE)	9– Reset button
5– Factory Reset/Mode button	

Figure 23 on page 32 shows the components on the rear panel of EX4100-F-48P switch.

Figure 23: Components on the Rear Panel of EX4100-F-48P Switch

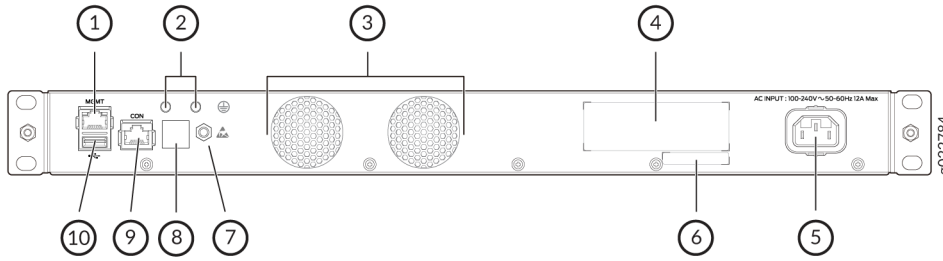

1– RJ-45 management port (labeled MGMT)	6– CLEI code label
2– Protective earthing terminal	7– Electrostatic discharge (ESD) point
3– Built-in fan modules	8– Claim Code label
4– Serial number	9– RJ-45 console port (labeled CON)
5– AC power supply socket	10– USB 2.0 Type-A port

Table 14 on page 32 lists the components shipped with EX4100-F-48P switch models.

Table 15 on page 32 describes the physical specifications and ports of EX4100-F-48P switches.

Table 14: EX4100-F-48P Switch Models, Shipped Components, and First Junos Release

Model Number	Built-in Fans	Built-in power supply	First Junos OS Release
EX4100-F-48P	Two built-in fan units with front-to-back airflow.	Built-in 850 W AC power supply	22.2R1

Table 15: EX4100-F-48P Switches—Physical Specifications and Ports

Item	Description
Chassis Dimensions	Height - 1.72 in (4.37 cm) Depth - 12.2 in (31.13 cm)
Weight	5200g

Table 15: EX4100-F-48P Switches—Physical Specifications and Ports (Continued)

Item	Description
Built-in ports	<ul style="list-style-type: none"> • 48 1GbE Ethernet ports • 4 1GbE/10GbE SFP+ Virtual Chassis ports • 4 10GE SFP+ uplink ports
PoE ports	48 PoE+ (30 W by default)

EX4100-F-48T

Components on the Front and Rear Panels of EX4100-F-48T Switches

Figure 24 on page 33 shows the front view of an EX4100-F-48T switch.

Figure 24: Front View of the EX4100-F-48T Switch



Figure 25 on page 33 shows the rear view of the EX4100-F-48T switch with 24 ports.

Figure 25: Rear View of the EX4100-F-48T Switch



Figure 26 on page 34 shows the components on the front panel of the EX4100-F-48T switch.

Figure 26: Components on the Front Panel of the EX4100-F-48T Switch

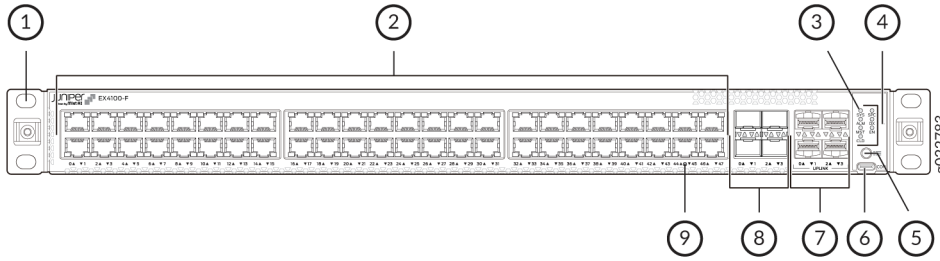

1– Front mounting brackets	6– RS232 to USB Type-C console port
2– 10/100/1000BASE-T RJ-45 non-PoE network ports.	7– 10 GE SFP+ Uplink ports
3– Chassis status LEDs (labeled SYS , ALM , MST , and CLD)	8– 1/10 GE SFP+ Virtual Chassis ports
4– Port mode LEDs (labeled SPD , DX , and EN)	9– Reset button
5– Factory Reset/Mode button	

Figure 27 on page 34 shows the components on the rear panel of EX4100-F-48T switch.

Figure 27: Components on the Rear Panel of EX4100-F-48T Switch

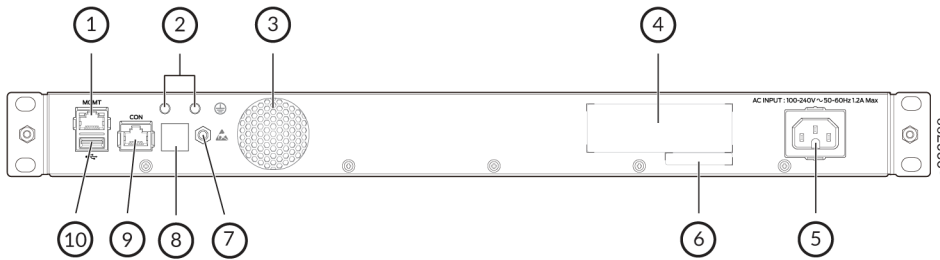

1– RJ-45 management port (labeled MGMT)	6– CLEI code label
2– Protective earthing terminal	7– Electrostatic discharge (ESD) point
3– Built-in fan module	8– Claim Code label
4– Serial number	9– RJ-45 console port (labeled CON)
5– AC power supply socket	10– USB 2.0 Type-A port

Table 16 on page 35 lists the components shipped with EX4100-F-48T switch models.

Table 17 on page 35 describes the physical specifications and ports of EX4100-F-48T switches.

Table 16: EX4100-F-48T Switch Models, Shipped Components, and First Junos Release

Model Number	Built-in Fans	Built-in power supply	First Junos OS Release
EX4100-F-48T	One built-in fan with front-to-back airflow	Built-in 90 W AC power supply	22.2R1

Table 17: EX4100-F-48T Switches—Physical Specifications and Ports

Item	Description
Chassis Dimensions	Height - 1.72 in (4.37 cm) Depth - 10.1 in (25.65 cm)
Weight	3885g
Built-in ports	<ul style="list-style-type: none"> • 48 1GbE Ethernet ports • 4 1GbE/10GbE SFP+ Virtual Chassis ports • 4 10GE SFP+ uplink ports
PoE ports	0

EX4100-F Chassis

IN THIS SECTION

- [Chassis Physical Specifications for EX4100-F Switches | 36](#)
- [Chassis Status LEDs on EX4100-F Switches | 42](#)
- [LEDs on the Management Port on EX4100-F Switches | 44](#)
- [LEDs on the RJ-45 Network Ports, Virtual Chassis Ports, and Uplink Ports on EX4100-F Switches | 46](#)

Chassis Physical Specifications for EX4100-F Switches

The EX4100-F switch chassis is a rigid sheet-metal structure that houses all components of the switch.

Figure 28: Clearance Requirements for Airflow and Hardware Maintenance for EX4100-F-12P and EX4100-F-12T switches

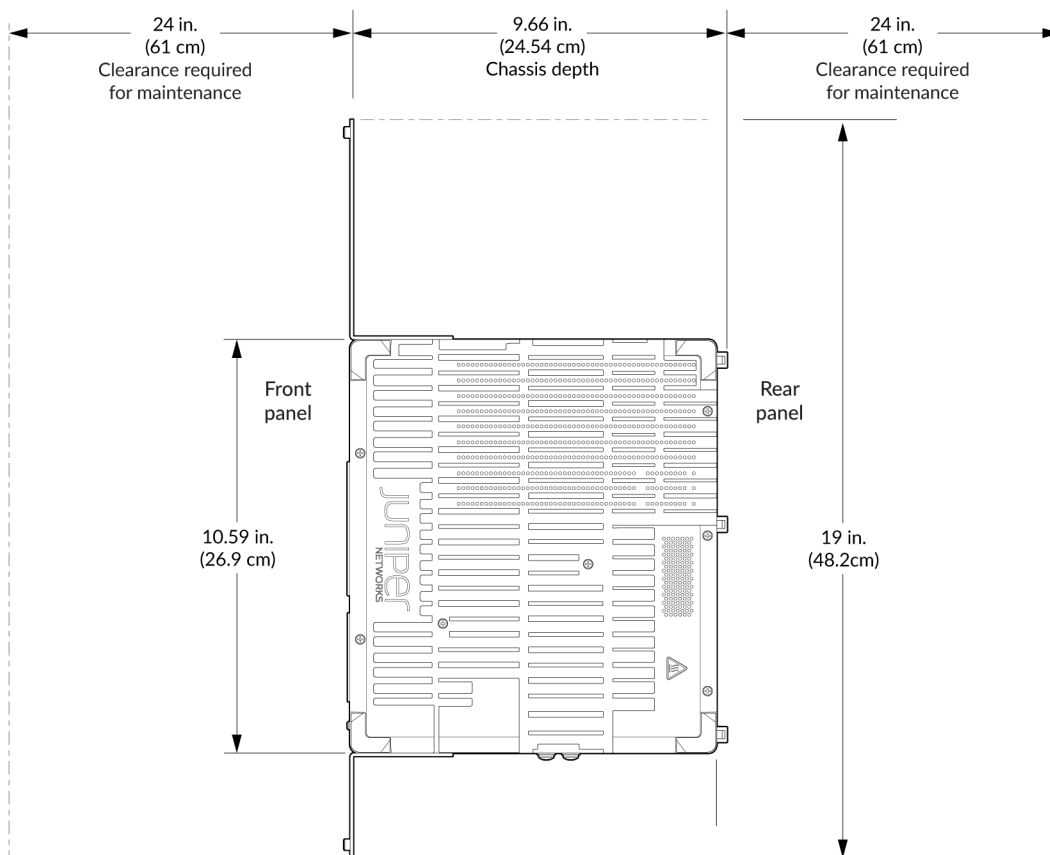

8022835

Figure 29: Clearance Requirements for Airflow and Hardware Maintenance for the EX4100-F-24T Switch

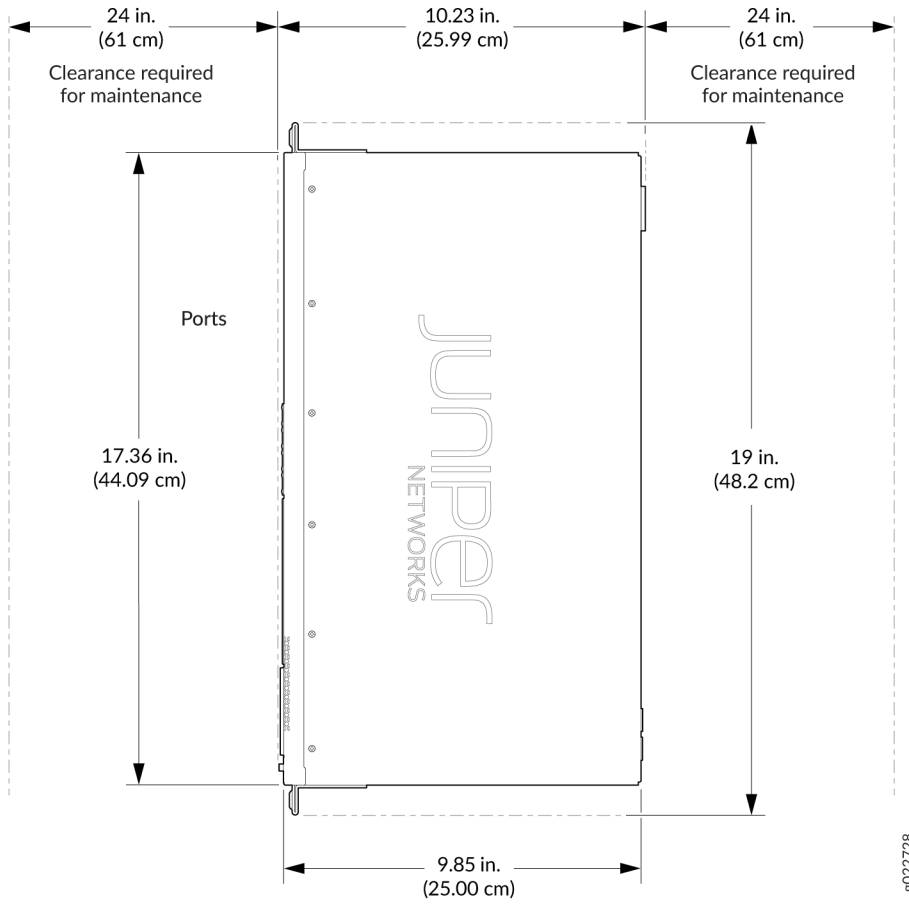

Figure 30: Clearance Requirements for Airflow and Hardware Maintenance for the EX4100-F-24P Switch

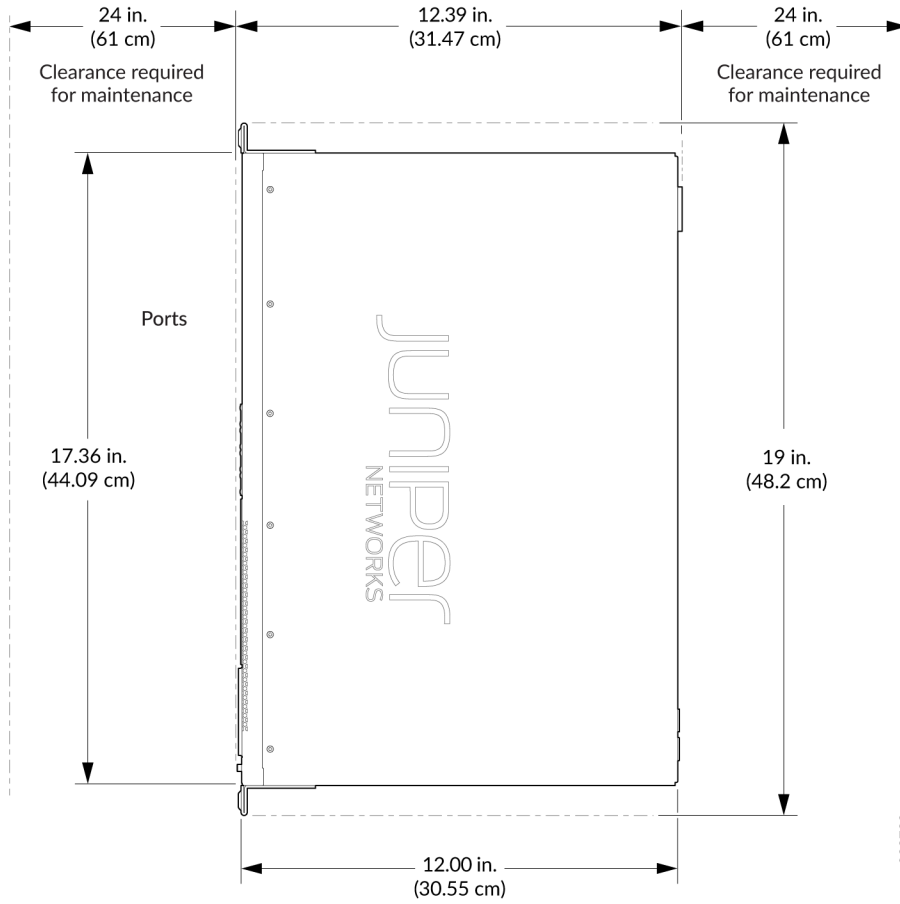

Figure 31: Clearance Requirements for Airflow and Hardware Maintenance for the EX4100-F-48P Switch

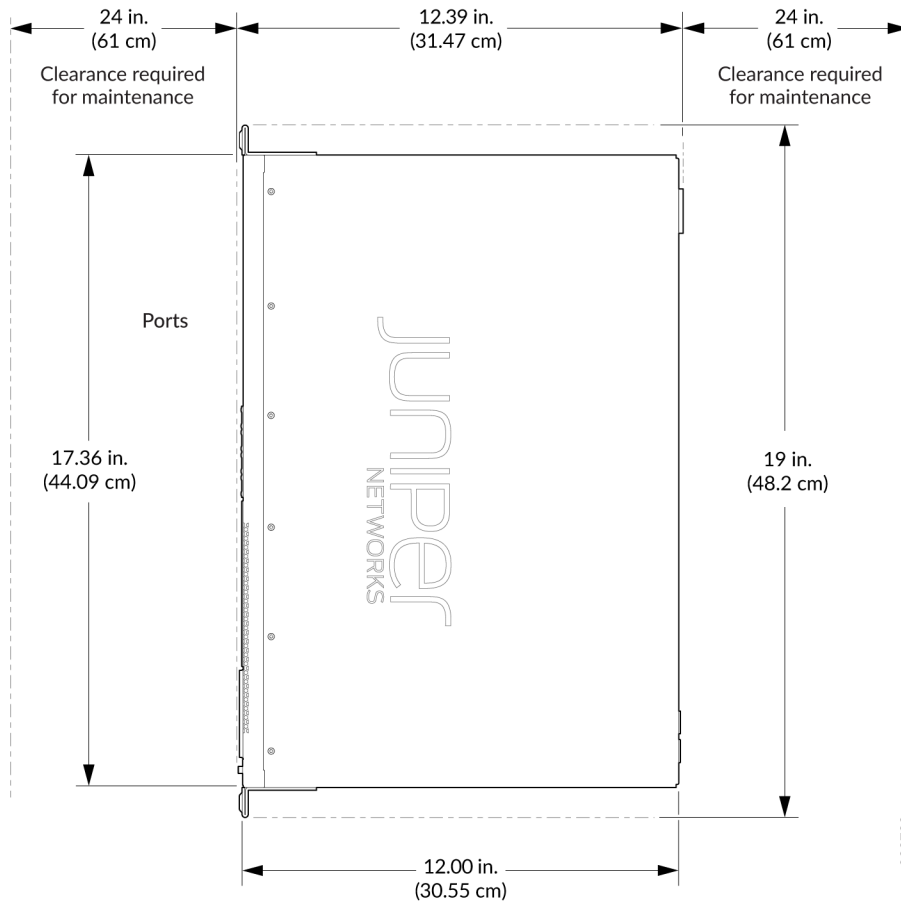
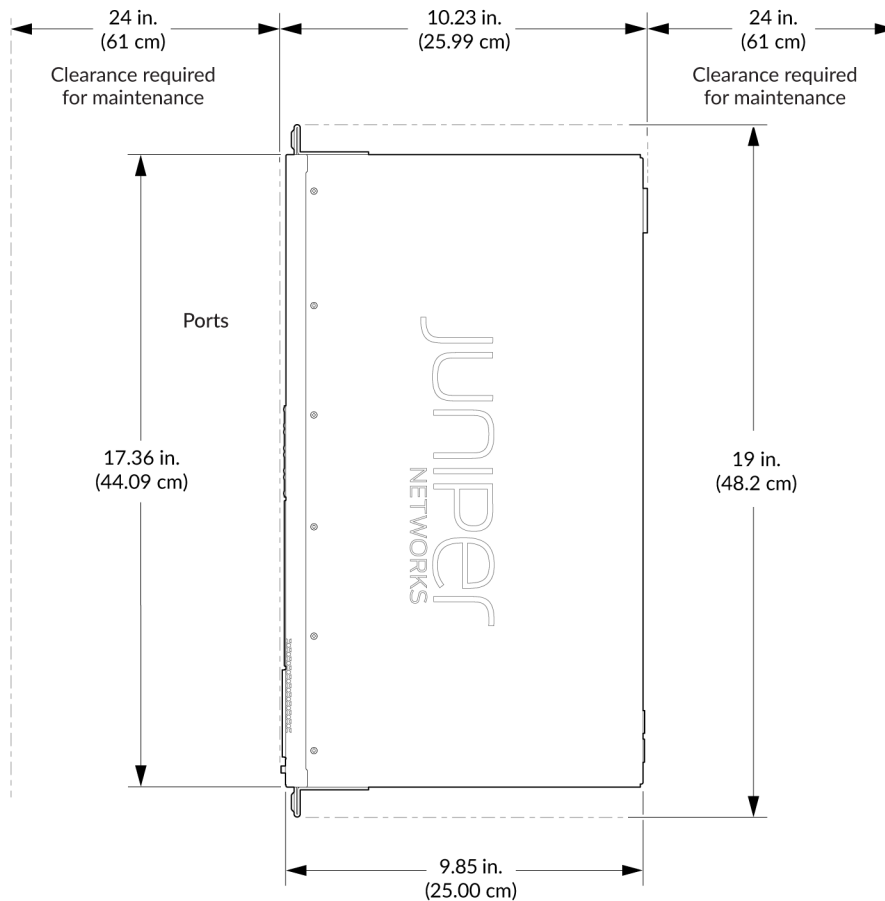

Figure 32: Clearance Requirements for Airflow and Hardware Maintenance for the EX4100-F-48T Switch



- For the cooling system to function properly, the airflow around the chassis must be unrestricted.
- If you are mounting the switch in a rack or cabinet with other equipment, or if you are placing it on the desktop or floor near other equipment, ensure that the exhaust from other equipment does not blow into the intake vents of the chassis.
- Leave at least 24 in. (61 cm) in front of the switch and behind the switch. For service personnel to remove and install hardware components, you must leave adequate space at the front and back of the switch. It is recommended that you allow at least 30 in. (76.2 cm) in front of the rack or cabinet and 24 in. (61 cm) behind the rack or cabinet.

Table 18: Physical Specifications of the EX4100-F Switch Chassis

Model	Chassis Height	Chassis Depth		Chassis Weight with Power Supply and Fan Module
		With no power supply and fan module	With power supply and fan module installed	
EX4100-F-24T	1.72 in (4.37 cm)	NA	10.1 in (25.65 cm)	3520g
EX4100-F-24P	1.72 in (4.37 cm)	NA	12.2 in (31.13 cm)	4745g
EX4100-F-48P	1.72 in (4.37 cm)	NA	12.2 in (31.13 cm)	5200g
EX4100-F-48T	1.72 in (4.37 cm)	NA	10.1 in (25.65 cm)	3885g

Table 19: Physical Specifications of the EX4100-F-12P and EX4100-F-12T Switch Chassis

Model	Chassis Height	Chassis Depth	Chassis Weight
EX4100-F-12P	1.75 in (4.44 cm)	9.66 in (24.54 cm)	3000g
EX4100-F-12T	1.75 in (4.44 cm)	9.66 in (24.54 cm)	2700g

Table 20: Physical Specifications of the External Power Supply Adaptors of EX4100-F-12P and EX4100-F-12T Switches

Model	Power Supply Adaptor (w)	Height	Width	Depth	Weight
EX4100-F-12P	280	1.77 in (4.5 cm)	3.93 in (10 cm)	7.87 in (20 cm)	1350g
EX4100-F-12T	75	1.43 in (3.65 cm)	2.63 in (6.7 cm)	6.10 in (15.5 cm)	750g

Table 21: Acoustic Noise Measurements for EX4100-F Switch Models

Switch Model	Power Supply	Sound Pressure (Acoustics)	
		LpA (dB) Typical 1PSU/2PSU	Max 1PSU/2PSU
EX4100-F-24T	65W AC AFO	NA	35.4
EX4100-F-24P	450W AC AFO	40.1	45.1
EX4100-F-48T	90W AC AFO	NA	37.1
EX4100-F-48P	850 AC AFO	46.2	46.5

Chassis Status LEDs on EX4100-F Switches

EX4100-F switches have four chassis status LEDs (labeled **SYS**, **ALM**, **MST**, and **CLD**) on the rightside of the front panel .

Figure 33: Chassis Status LEDs in EX4100-F Switches

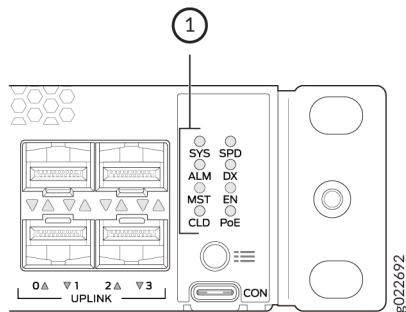

1– Chassis status LEDs

Table 22 on page 43 describes the chassis status LEDs labeled **SYS**, **ALM**, and **MST** on an EX4100-F switch. The table also describes their colors and states and the status each LED indicates. You can view the colors of the LEDs remotely through the CLI by issuing the `show chassis led operational mode` command. All LEDs can be lit simultaneously.

For information on the blink patterns of the CLD LED, which provide the cloud connection status of the switch, see [Cloud Ready LED Blink Patterns](#) or see [Cloud Connection Process](#) to understand how the cloud connection works.

Table 22: SYS, ALM, and MST Chassis Status LEDs on EX4100-F Switches

LED Label	Color	State and Description
SYS	Green	<ul style="list-style-type: none"> On steadily—Junos OS for EX Series switches is loaded on the switch. Blinking—The switch is booting.
	Unlit	The switch is powered off or is halted.
ALM	Red	<p>A major hardware fault—such as a temperature alarm or a power failure alarm—occurred, and the switch is halted.</p> <p>A major alarm indicates a critical error condition that requires immediate attention (see "Chassis Component Alarm Conditions on EX4100-F Switches" on page 194).</p>
	Amber	<p>A minor alarm—such as a software or a hardware error—occurred. Power off the switch and then power it back on. Monitor the switch to see whether it is working properly.</p> <p>A minor alarm indicates a non-critical condition that requires monitoring or maintenance. A minor alarm that is left unchecked might cause interruption in service or performance degradation.</p>
	Unlit	No alarm is in effect, or the switch is halted.

Table 22: SYS, ALM, and MST Chassis Status LEDs on EX4100-F Switches (*Continued*)

LED Label	Color	State and Description
MST	Green	In a standalone switch: <ul style="list-style-type: none"> • On steadily—The switch is functioning normally. • Off—The switch is powered off or is halted.
		In a Virtual Chassis configuration: <ul style="list-style-type: none"> • On steadily—The switch is the primary switch in the Virtual Chassis configuration. • Blinking—The switch is the backup switch in the Virtual Chassis configuration. • Off—The switch is a linecard member in the Virtual Chassis configuration, or the switch is halted.

NOTE: When issuing `show system alarms`, only the ALM LED of the master switch in a virtual chassis system glows to display the alarm state. Backup switch and linecard ALM LEDs will be unlit. However, when issuing `show chassis alarms`, ALM LED glows on all of the individual member switches, displaying their individual alarm states.

NOTE: For Virtual Chassis deployments managed from the cloud, the CLD LED on individual Virtual Chassis members will reflect the state of the Master, except when a software download is in progress. When a software download is in progress, the CLD LED on a Virtual Chassis member will display the Junos OS upgrading LED pattern and color.

LEDs on the Management Port on EX4100-F Switches

The management port, labeled **MGMT**, on the rear panel of EX4100-F switches has two LEDs that indicate link activity and port status.

Figure 34: LEDs on the Management Port on EX4100-F Switches

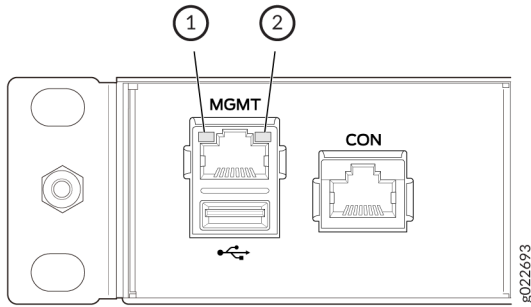

1– Link activity LED

2– Status LED

The following table describes the LEDs.

Table 23: LEDs on the Management Port on EX4100-F Switches

LED	Color	State and Description
Link activity	Green	<ul style="list-style-type: none"> • On steadily—The port and the link are active, but no link activity is occurring. • Blinking—The port and the link are active, and link activity is occurring. • Off—The port is not active.
Status	Green	Indicates the speed: <ul style="list-style-type: none"> • On steadily—Link speed is 1000 Mbps. • On steadily—Link speed is 100 Mbps. • Off—Link speed is 10 Mbps.

LEDs on the RJ-45 Network Ports, Virtual Chassis Ports, and Uplink Ports on EX4100-F Switches

IN THIS SECTION

- LEDs on the Network Ports | 46

The RJ-45 network ports, SFP+ uplink ports, and SFP+/SFP28 Virtual Chassis Ports on EX4100-F switches have LEDs that show the link activity and port status.

LEDs on the Network Ports

The figures in this section show and describe the LEDs on the following ports:

- [Figure 35 on page 46](#) shows the LEDs on the RJ-45 network ports on EX4100-F switches.
- [Figure 36 on page 47](#) shows the LEDs on the SFP+ uplink ports.
- [Figure 37 on page 47](#) shows the LEDs on the SFP+/SFP28 Virtual Chassis Ports.
- [Table 24 on page 48](#) describes the link activity LED state and description on the RJ-45 ports, SFP+ uplink ports, and SFP+/SFP28 Virtual Chassis Ports.

Figure 35: LEDs on the RJ-45 Network Ports on EX4100-F Switches

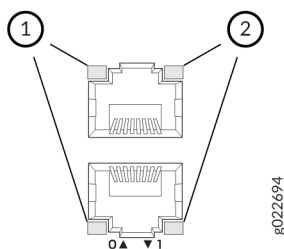

1– Link activity LED

2– Status LED

Figure 36: LEDs on the SFP+ uplink ports on EX4100-F Switches

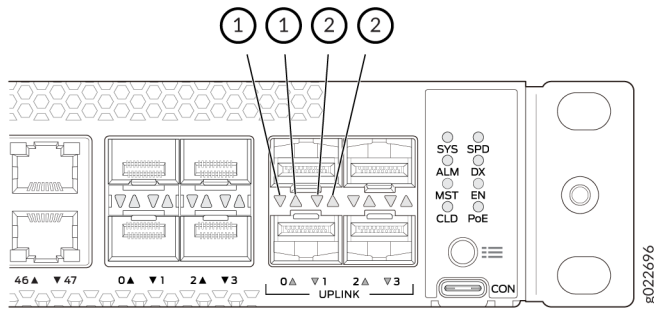

1- Link activity LED

2- Status LED

NOTE: The status LEDs on the port number 24 - 47 will be updated with a delay which varies from 1 second to 9 seconds when a cable is plugged or unplugged.

Figure 37: LEDs on the SFP+/SFP28 Virtual Chassis ports on EX4100-F Switches

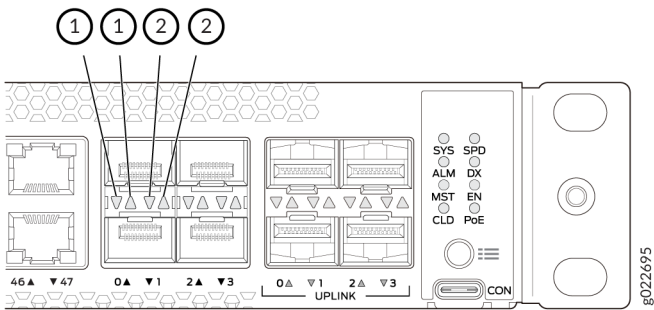

1- Link activity LED

2- Status LED

Table 24: Link Activity LED on the Network Ports, Uplink Ports, and Virtual Chassis Ports

Link Activity LED Color	Link Status LED State and Description
Green	<ul style="list-style-type: none"> On steadily—The port and the link are active, but no link activity is occurring. Blinking—The port and the link are active, and link activity is occurring. Off—The port is not active.

EX4100-F switches have network port mode LEDs (labeled **SPD**, **DX**, **EN**, and **POE**) on the right side of the front panel (see [Figure 38 on page 48](#).) These LEDs indicate the status of the network ports. Use the mode button on the right side of the front panel to toggle the status LEDs. You toggle the status LEDs to show the different port parameters for the network ports. The LED that is lit indicates the port parameter. [Table 25 on page 49](#) describes the status LEDs.

NOTE: The LED labeled PoE is not available on switch models with network ports that do not provide PoE.

Figure 38: Port Mode LEDs on EX4100-F Switches

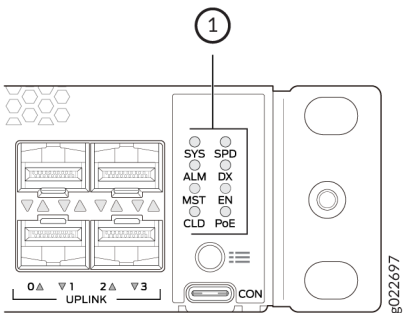

1– Port Mode LEDs

Table 25: Port Status of Network Ports Based on States of Port Mode LEDs

LED	Color	State and Description
SPD	Green	<p>Indicates the speed. The speed indicators are as follows:</p> <ul style="list-style-type: none"> • On steadily—1000 Mbps • On steadily (for EX4100-F uplink and virtual chassis ports)—10 Gbps • Blinking—100 Mbps • Blinking; 1 blink per second (for EX4100-F uplink and virtual chassis ports)—1000 Mbps • Blinking; 3 blinks per second (for EX4100-F uplink and virtual chassis ports)—25 Gbps • Unlit—10 Mbps
DX	Green	<p>Indicates the duplex mode. The status indicators are as follows:</p> <ul style="list-style-type: none"> • On steadily—The port is set to full-duplex mode. • Unlit—The port is set to half-duplex mode.
EN	Green	<p>Indicates the administrative status. The status indicators are as follows:</p> <ul style="list-style-type: none"> • On steadily—The port is administratively enabled. • Unlit—The port is administratively disabled.
POE	Green	<p>Indicates the PoE mode. The status indicators are as follows:</p> <ul style="list-style-type: none"> • On steadily—PoE is enabled on the port, and a device is drawing power. • Blinking—PoE is enabled on the port, but nothing is drawing power from the port. • Unlit—PoE is not enabled on the port.

Cooling System and Airflow in an EX4100-F Switch

IN THIS SECTION

- [Airflow Direction in EX4100-F Switch Models | 50](#)
- [EX4100-F Switches with Front-to-Back Airflow | 51](#)
- [How to Position the Switch | 55](#)

The cooling system in EX4100-F switch consists of fanless models and models with built-in fan(s). EX4100-F-12P and EX4100-F-12T switch models are fanless and rely on natural convection cooling. The airflow direction depends on the fan modules and power supplies installed in the switch.

Airflow Direction in EX4100-F Switch Models

[Table 26 on page 50](#) shows the direction of airflow in EX4100-F models as shipped.

Table 26: Airflow Direction in EX4100-F Switch Models

Model Number	Fan Modules and Power Supply	Direction of Airflow
<ul style="list-style-type: none"> ● EX4100-F-24T ● EX4100-F-48T 	One built-in fan with AFO cooling.	Front-to-back—cold air to cool the chassis enters through the vents on the front panel of the chassis, and hot air exits through the vents on the rear panel of the chassis.

Table 26: Airflow Direction in EX4100-F Switch Models (*Continued*)

Model Number	Fan Modules and Power Supply	Direction of Airflow
<ul style="list-style-type: none"> • EX4100-F-24P • EX4100-F-48P 	Two built-in fans with AFO cooling.	Front-to-back—cold air to cool the chassis enters through the vents on the front panel of the chassis, and hot air exits through the vents on the rear panel of the chassis.

EX4100-F Switches with Front-to-Back Airflow

In EX4100-F switch models with front-to-back airflow, air enters through vents on the front panel to cool the chassis. The hot air then exits through the vents on the rear panel.

NOTE: The front side of a switch is the side where the ports are located. The rear side is where the fans are located.

Figure 39: Front-to-Back Airflow Through the EX4100-F-24P Switch Chassis



Figure 40: Front-to-Back Airflow Through the EX4100-F-24T Switch Chassis

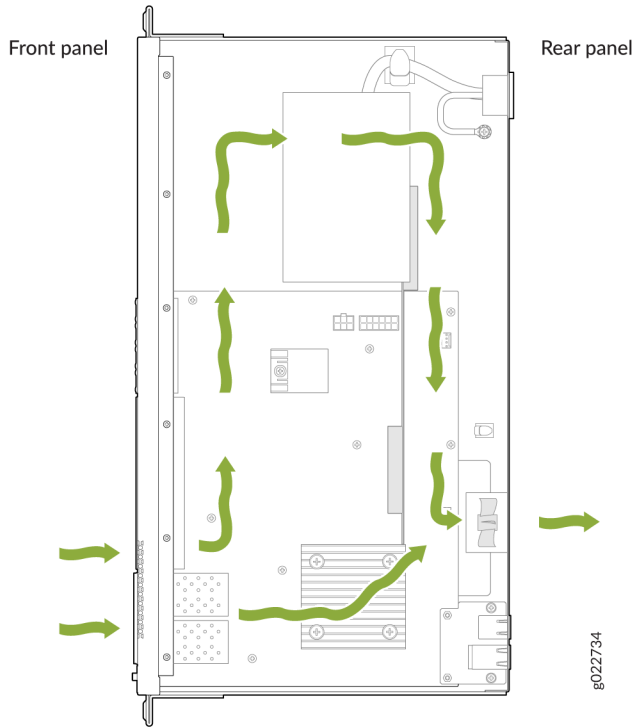
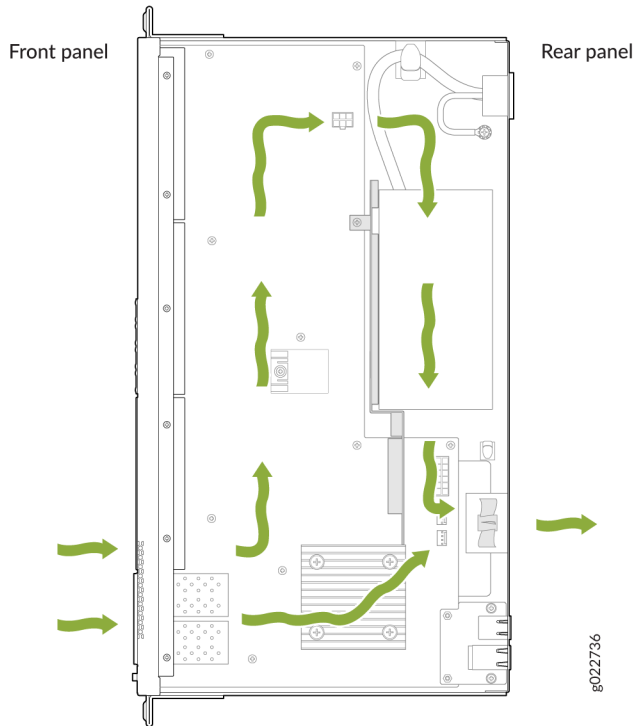

Figure 41: Front-to-Back Airflow Through the EX4100-F-48P Switch Chassis



Figure 42: Front-to-Back Airflow Through the EX4100-F-48T Switch Chassis



How to Position the Switch

Position the switch with front-to-back airflow in such a manner that the **AIR OUT** labels on the fan modules and power supplies are next to the hot aisle (see [Figure 43 on page 55](#)).

Figure 43: Deployment of Switches with Front-to-Back Airflow Through the Switch Chassis

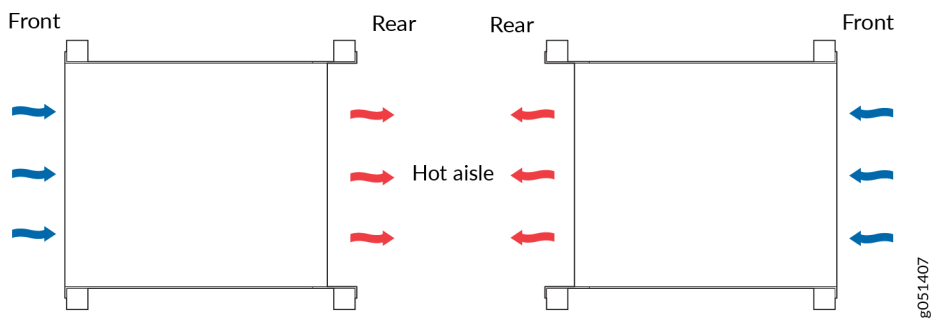

Position the switch with back-to-front airflow in such a manner that the **AIR IN** labels on the fan modules and power supplies are next to the cold aisle (see [Figure 44 on page 56](#)).

Figure 44: Deployment of Switches with Back-to-Front Airflow Through the Switch Chassis

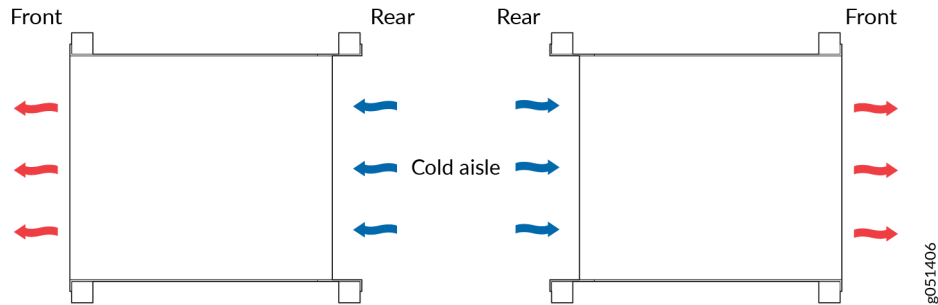

EX4100-F Power System

IN THIS SECTION

- [AC Power Supply in EX4100-F Switches | 56](#)

AC Power Supply in EX4100-F Switches

IN THIS SECTION

- [Characteristics of AC Power Supply in EX4100-F Switches | 57](#)
- [Specifications of the AC Power Supplies Used in EX4100-F Switches | 58](#)
- [PoE Budget Planning | 58](#)

- Specifications of the Power Cord for AC Power Supplies for EX4100-F Switches | 60

Characteristics of AC Power Supply in EX4100-F Switches

- The EX4100-F-12P and EX4100-F-12T switches use the 280-W and 75-W external power adapters respectively.
- EX4100-F-24P, EX4100-F-24T, EX4100-F-48P, and EX4100-F-48T use built-in 450-W, 65-W, 850-W, and 90-W, AC power supplies respectively. The built-in AC power supplies support Power over Ethernet (PoE+) in EX4100-F-24P and EX4100-F-48P switch models.

Refer [Table 5 on page 20](#) to check which EX4100-F models use which built-in power supplies.

Figure 45: External power adapter (280 W) used for EX4100-F-12P

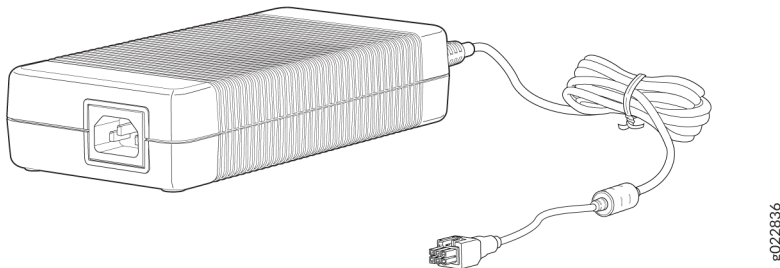
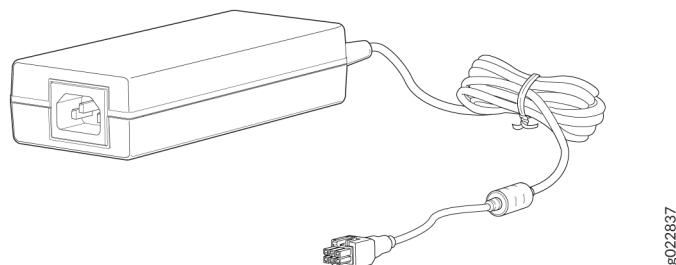

Figure 46: External power adapter (75 W) used for EX4100-F-12T



Specifications of the AC Power Supplies Used in EX4100-F Switches

- [Table 27 on page 58](#) provides the power supply specifications of the built-in AC Power Supplies in EX4100-F switches.

Table 27: Specifications of the Built-in AC Power Supplies Used in EX4100-F Switches

Item	Specification
850 W	<ul style="list-style-type: none"> • Input voltage range: 100 - 240 V • 50/60 Hz
450 W	<ul style="list-style-type: none"> • Input voltage range: 100 - 240 V • 50/60 Hz
90 W	<ul style="list-style-type: none"> • Input voltage range: 100 - 240 V • 50/60 Hz
65 W	<ul style="list-style-type: none"> • Input voltage range: 100 - 240 V • 50/60 Hz

PoE Budget Planning

[Table 28 on page 59](#) shows the PoE Budget Planning Details of EX4100-F-12P Switches. [Table 29 on page 60](#) shows the PoE budget planning details in EX4100-F-24P and EX4100-F-48P switch models.

Table 28: PoE Budget Planning Details of EX4100-F-12P Switches

Power Source					
External adapter (280 W)	PoE++ PSE (power supply equipment) (90 W)	PoE++ PSE (60 W)	PoE+ PSE (30 W)	Connected to how many uplink ports	Total PoE budget (W)
Y	-	-	-	-	180
-	Y	-	-	1	0
-	Y	-	-	2	60
Y	Y	-	-	1	240
Y	Y	-	-	2	300
-	-	Y	-	2	30
Y	-	Y	-	1	225
Y	-	Y	-	2	270
Y	-	-	Y	1	200
Y	-	-	Y	2	220

NOTE: Apart from the aforementioned combinations, any other combination will be insufficient to power the switch.

Table 29: PoE Budget Planning Details of EX4100-F-24P and EX4100-F-48P Switch Models

Model	System Budget	PoE Budget	Total Budget	Total PSU power
F-48P	87 W	740 W	827 W	850 W
F-24P	73 W	370 W	443 W	450 W

Specifications of the Power Cord for AC Power Supplies for EX4100-F Switches

A detachable AC power cord is supplied with the AC power supplies. The coupler is type C13 as described by International Electrotechnical Commission (IEC) standard 60320. The plug end of the power cord fits into the power source outlet that is standard for your geographical location.



CAUTION: The AC power cord provided with each power supply is intended for use with that power supply only and not for any other use.

NOTE: In North America, AC power cords must not exceed 4.5 meters (approximately 14.75 feet) in length, to comply with National Electrical Code (NEC) Sections 400-8 (NFPA 75, 5-2.2) and 210-52 and with Canadian Electrical Code (CEC) Section 4-010(3). The cords supplied with the switch are in compliance.

Table 30 on page 60 gives the AC power cord specifications for the countries and regions listed in the table.

Table 30: AC Power Cord Specifications

Country or Region	Electrical Specifications	Plug Standards	Juniper Model Number
Argentina	250 VAC, 10 A, 50 Hz	IRAM 2073 Type RA/3	CBL-EX-PWR-C13-AR
Australia	250 VAC, 10 A, 50 Hz	AS/NZZS 3112 Type SAA/3	CBL-EX-PWR-C13-AU
Brazil	250 VAC, 10 A, 50 Hz	NBR 14136 Type BR/3	CBL-EX-PWR-C13-BR

Table 30: AC Power Cord Specifications (Continued)

Country or Region	Electrical Specifications	Plug Standards	Juniper Model Number
China	250 VAC, 10 A, 50 Hz	GB 1002-1996 Type PRC/3	CBL-EX-PWR-C13-CH
Europe (except Italy, Switzerland, and the United Kingdom)	250 VAC, 10 A, 50 Hz	CEE (7) VII Type VIIG	CBL-EX-PWR-C13-EU
India	250 VAC, 10 A, 50 Hz	IS 1293 Type IND/3	CBL-EX-PWR-C13-IN
Israel	250 VAC, 10 A, 50 Hz	SI 32/1971 Type IL/3G	CBL-EX-PWR-C13-IL
Italy	250 VAC, 10 A, 50 Hz	CEI 23-16 Type I/3G	CBL-EX-PWR-C13-IT
Japan	125 VAC, 12 A, 50 Hz or 60 Hz	SS-00259 Type VCTF	CBL-EX-PWR-C13-JP
Korea	250 VAC, 10 A, 50 Hz or 60 Hz	CEE (7) VII Type VIIGK	CBL-EX-PWR-C13-KR
North America*	125 VAC, 13 A, 60 Hz	NEMA 5-15 Type N5-15	CBL-EX-PWR-C13-US
	125 VAC, 15 A, 60 Hz	NEMA 5-15 Type N5-15	CBL-PWR-C13-US-48P
South Africa	250 VAC, 10 A, 50 Hz	SABS 164/1:1992 Type ZA/13	CBL-EX-PWR-C13-SA
Switzerland	250 VAC, 10 A, 50 Hz	SEV 6534-2 Type 12G	CBL-EX-PWR-C13-SZ
United Kingdom	250 VAC, 10 A, 50 Hz	BS 1363/A Type BS89/13	CBL-EX-PWR-C13-UK

NOTE: For North America, use AC power cords with specifications for EX4100-F-48P.

Figure 47 on page 62 illustrates the plug on the power cord for some of the countries or regions listed in Table 30 on page 60.

Figure 47: AC Plug Types

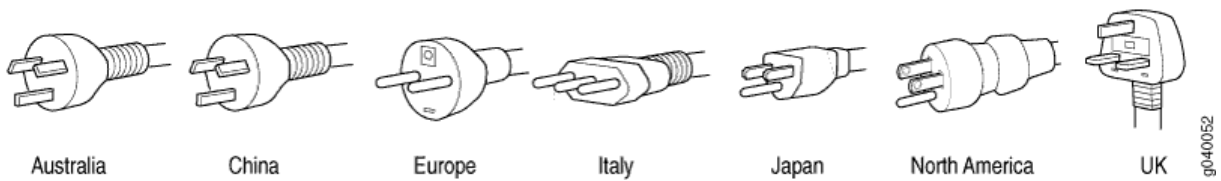

CAUTION: Do not use the AC power cord with any other product other than EX4100-F.



CAUTION: Power cords must not block access to switch components.

3

CHAPTER

Site Planning and Preparation

Site Preparation Checklist for EX4100-F Switches | 64

EX4100-F Site Guidelines and Requirements | 66

EX4100-F Network Cable and Transceiver Planning | 78

EX4100-F Management Cable Specifications and Pinouts | 86

Site Preparation Checklist for EX4100-F Switches

The checklist in [Table 31 on page 64](#) summarizes the tasks you need to perform when preparing a site for EX4100-F switch installation.

Table 31: Site Preparation Checklist

Item or Task	For More Information	Performed By	Date
Environment			
Verify that environmental factors such as temperature and humidity are within switch tolerances.	"Environmental Requirements and Specifications for EX4100-F Switches" on page 67.		
Power			
Measure the distance between external power sources and the switch installation site.	Figure 28 on page 36, Figure 29 on page 37, Figure 30 on page 38, Figure 31 on page 39, and Figure 32 on page 40		
Locate sites to connect system grounding.			
Calculate the power consumption requirements.	<ul style="list-style-type: none"> "AC Power Supply in EX4100-F Switches" on page 56. 		
Hardware Configuration			
Choose the number and types of switches you want to install.	"EX4100-F System Overview" on page 12		
Rack or Cabinet			

Table 31: Site Preparation Checklist (Continued)

Item or Task	For More Information	Performed By	Date
Verify that the rack or cabinet meets the minimum requirements for installing the switch.	<ul style="list-style-type: none"> • "Rack Requirements" on page 69 • "Cabinet Requirements" on page 71 		
Plan rack or cabinet location, including required space clearances.			
Secure the rack or cabinet to the floor and building structure.			
Cables			
<p>Acquire cables and connectors:</p> <ul style="list-style-type: none"> • Determine the number of cables needed based on your planned configuration. • Review the maximum distance allowed for each cable. Choose the length of the cable based on the distance between the hardware components being connected. 			
Plan the cable routing and management.			
Wall			

Table 31: Site Preparation Checklist (Continued)

Item or Task	For More Information	Performed By	Date
Verify that the wall meets the minimum requirements for the installation of the switch. Note that EX4100-F wall mounting requirements are similar to EX3400 wall mounting requirements.	Requirements for Mounting an EX3400 Switch on a Desktop or Wall		
Wall mount using a magnet The ferrous wall is required to mount the EX4100-F-12P and/or EX4100-F-12T switch using a magnet pad.	Refer note section under " Mount an EX4100-F Switch on a Wall " on page 109		
Verify appropriate clearance exists in your selected location.	Figure 28 on page 36 , Figure 29 on page 37 , Figure 30 on page 38 , Figure 31 on page 39 , and Figure 32 on page 40		

EX4100-F Site Guidelines and Requirements

IN THIS SECTION

- [Environmental Requirements and Specifications for EX4100-F Switches | 67](#)
- [General Site Guidelines | 68](#)
- [Site Electrical Wiring Guidelines | 68](#)
- [Rack Requirements | 69](#)
- [Cabinet Requirements for EX4100-F Switches | 71](#)
- [Clearance Requirements for Airflow and Hardware Maintenance for EX4100-F Switches | 72](#)

Environmental Requirements and Specifications for EX4100-F Switches

You must install the switch in a rack or cabinet. You must house it in a dry, clean, well-ventilated, and temperature-controlled environment.

Follow these environmental guidelines:

- Ensure that the site is as dust-free as possible. Dust can clog air intake vents and filters, reducing the efficiency of the switch cooling system.
- Maintain ambient airflow for normal switch operation. If the airflow is blocked or restricted, or if the intake air is too warm, the switch might overheat. If the switch overheats, the switch temperature monitor may shut down the device to protect the hardware components.

The following are the required environmental conditions for normal switch operation of EX4100-F switches.

- Switch: All EX4100-F switch models
- Altitude: No performance degradation up to 5,000 feet (1, 524 meters)
- Relative humidity: Normal operation ensured in relative humidity range of 10% through 85%, noncondensing
- Temperature:
 - Normal operation ensured in temperature range of 32 °F through 113 °F (0 °C through 45 °C)
 - Nonoperating storage temperature in shipping container: -40 °F through 158 °F (-40 °C through 70 °C)
- Seismic tolerance: Tested for Zone 4 earthquake safety.

NOTE: With 10G-Base-T pluggable, max temperature is reduced to 40C up to 5,000ft elevation.

NOTE: Install the EX4100-F switch only in restricted areas, such as dedicated equipment rooms and equipment closets. Install the switch in accordance with Articles of the National Electrical Code, ANSI/NFPA 70.

NOTE: For EX4100-F-12P, max operating temperature is limited to 40C, 5000 feet for Under the Desk mounting. For desk mounting and two-post rack mounting configurations, max operating temperature is limited to 44C, 5000 feet.

For rack mounting of EX4100-F-12P and EX4100-F-12T, 3RU clearance is required above the units.

Industrial grade SFP+ optics (10GE) is required for EX4100-F-12P and EX4100-F-12T above 40C operating ambient temperature.

General Site Guidelines

Efficient device operation requires proper site planning and maintenance. It also requires proper layout of the equipment, rack or cabinet, and wiring closet.

To plan and create an acceptable operating environment for your device and prevent environmentally caused equipment failures:

- Keep the area around the chassis free from dust and conductive material, such as metal flakes.
- Follow the prescribed airflow guidelines to ensure that the cooling system functions properly. Ensure that exhaust from other equipment does not blow into the intake vents of the device.
- Follow the prescribed electrostatic discharge (ESD) prevention procedures to prevent damaging the equipment. Static discharge can cause components to fail completely or intermittently over time.
- Install the device in a secure area, so that only authorized personnel can access the device.

Site Electrical Wiring Guidelines

[Table 32 on page 69](#) describes the factors you must consider while planning the electrical wiring at your site.



WARNING: You must provide a properly grounded and shielded environment and use electrical surge-suppression devices.

Avertissement Vous devez établir un environnement protégé et convenablement mis à la terre et utiliser des dispositifs de parasurtension.

Table 32: Site Electrical Wiring Guidelines

Site Wiring Factor	Guidelines
Signaling limitations	<p>If your site experiences any of the following problems, consult experts in electrical surge suppression and shielding:</p> <ul style="list-style-type: none"> • Improperly installed wires cause radio frequency interference (RFI). • Damage from lightning strikes occurs when wires exceed recommended distances or pass between buildings. • Electromagnetic pulses (EMPs) caused by lightning damage unshielded conductors and electronic devices.
Radio frequency interference	<p>To reduce or eliminate RFI from your site wiring, do the following:</p> <ul style="list-style-type: none"> • Use a twisted-pair cable with a good distribution of grounding conductors. • If you must exceed the recommended distances, use a high-quality twisted-pair cable with one ground conductor for each data signal, when applicable.
Electromagnetic compatibility	<p>If your site is susceptible to problems with electromagnetic compatibility (EMC), particularly from lightning or radio transmitters, seek expert advice.</p> <p>Strong sources of electromagnetic interference (EMI) can cause:</p> <ul style="list-style-type: none"> • Destruction of the signal drivers and receivers in the device • Electrical hazards as a result of power surges conducted over the lines into the equipment.

Rack Requirements

You can mount the device on two-post racks or four-post racks.

Rack requirements consist of:

- Rack type.
- Mounting bracket hole spacing.
- Rack size and strength.

- Rack connection to the building structure.

Table 33 on page 70 provides the rack requirements and specifications.

Table 33: Rack Requirements and Specifications

Rack Requirement	Guidelines
Rack type	<p>A U is the standard rack unit defined by the Electronic Components Industry Association (http://www.ecianow.org).</p> <p>You can mount the device on a rack that provides bracket holes or hole patterns spaced at 1U (1.75 in. or 4.45 cm) increments and meets the size and strength requirements to support the weight.</p>
Mounting bracket hole spacing	<p>The holes in the mounting brackets are spaced at 1U (1.75 in. or 4.45 cm) so that the device can be mounted in any rack that provides holes spaced at that distance.</p>
Rack size and strength	<p>Ensure that the:</p> <ul style="list-style-type: none"> • Rack complies with the size and strength standards of a 19-in. rack as defined by the Electronic Components Industry Association (http://www.ecianow.org). • Rack rails are spaced widely enough to accommodate the external dimensions of the device chassis. Ensure also that the outer edges of the front mounting brackets extend the width of the chassis to 19 in. (48.2 cm). • Rack is strong enough to support the weight of the device. • Spacing of rails and adjacent racks provides for proper clearance around the device and rack.
Rack connection to building structure	<p>Secure the rack as follows:</p> <ul style="list-style-type: none"> • Secure the rack to the building structure. • If your geographical area is earthquake-prone, secure the rack to the floor. • Secure the rack to the ceiling brackets as well as wall or floor brackets for maximum stability.

SEE ALSO

[Rack-Mounting and Cabinet-Mounting Warnings](#)

Cabinet Requirements for EX4100-F Switches

You can mount the device in a cabinet that contains a 19-in. rack.

Cabinet requirements consist of:

- Cabinet size.
- Clearance requirements.
- Cabinet airflow requirements.

Table 34: Cabinet Requirements and Specifications

Cabinet Requirement	Guidelines
Cabinet size	<ul style="list-style-type: none"> • For EX4100-F-12P and EX4100-F-12T, the minimum cabinet size is 27 in. (68.5 cm) deep. Large cabinets improve airflow and reduce chances of overheating
Cabinet clearance	<ul style="list-style-type: none"> • For EX4100-F-12P and EX4100-F-12T switches 22 inch (55.88 cm) internal free space is required within the cabinet.

Table 34: Cabinet Requirements and Specifications *(Continued)*

Cabinet Requirement	Guidelines
Cabinet airflow requirements	<p>When you mount the device in a cabinet, ensure that ventilation through the cabinet is sufficient to prevent overheating, as follows:</p> <ul style="list-style-type: none"> • Ensure adequate cool air supply to dissipate the thermal output of the device or devices. • Ensure that the hot air exhaust of the chassis exits the cabinet without recirculating into the device. An open cabinet (without a top or doors) that employs hot air exhaust extraction from the top ensures the best airflow through the chassis. If the cabinet contains a top or doors, perforations in these elements assist with removing the hot air exhaust. • Install the device in the cabinet in a way that maximizes the open space on the side of the chassis that has the hot air exhaust. • Route and secure all cables to minimize the blockage of airflow to and from the chassis. • Ensure that the spacing of rails and adjacent cabinets is such that proper clearance exists around the device and cabinet. • A cabinet larger than the minimum required provides better airflow and reduces the chance of overheating.

Clearance Requirements for Airflow and Hardware Maintenance for EX4100-F Switches

When planning the site for installing an EX4100-F switch, you must allow sufficient clearance around the installed switch.

See:

- [Figure 48 on page 73](#) for clearance requirements for airflow and hardware maintenance for EX4100-F-12P and EX4100-F-12T switches.
- [Figure 49 on page 74](#) for clearance requirements for airflow and hardware maintenance for the EX4100-F-24T switch.
- [Figure 50 on page 75](#) for clearance Requirements for airflow and hardware maintenance for the EX4100-F-24P switch.
- [Figure 51 on page 76](#) for clearance requirements for airflow and hardware maintenance for the EX4100-F-48P switch.
- [Figure 52 on page 77](#) for clearance requirements for airflow and hardware maintenance for the EX4100-F-48T switch.

Figure 48: Clearance Requirements for Airflow and Hardware Maintenance for EX4100-F-12P and EX4100-F-12T switches

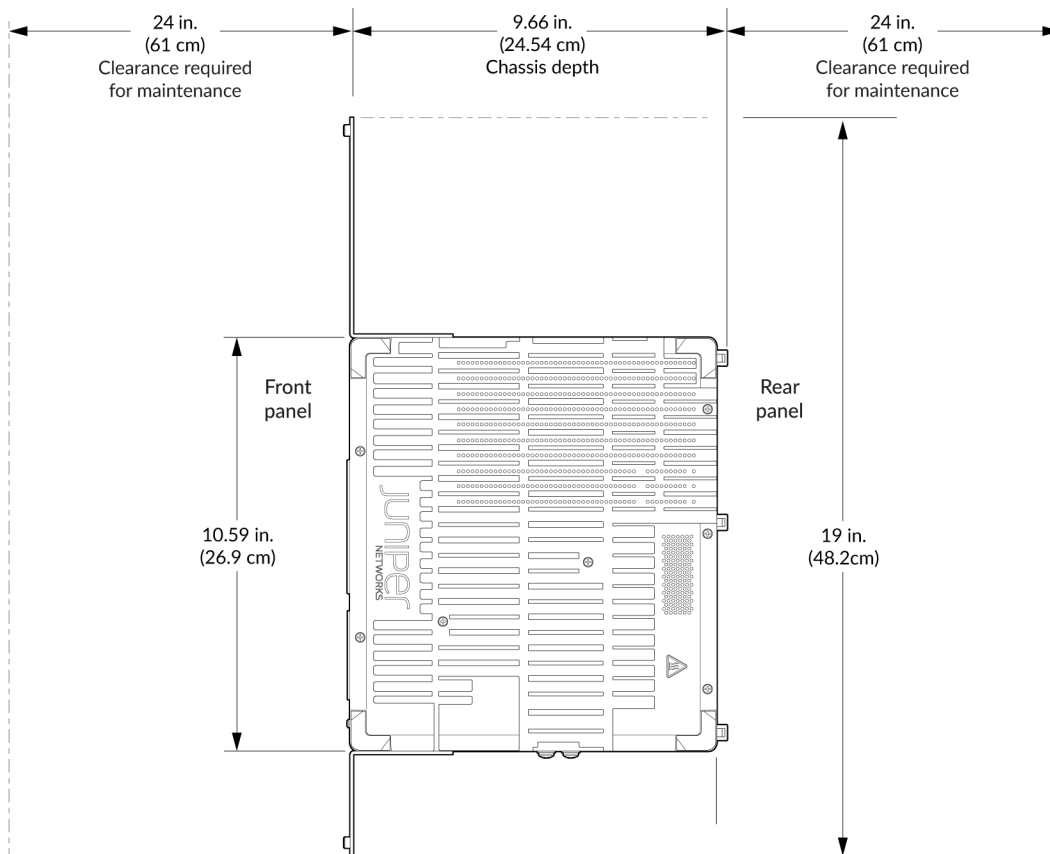

Figure 49: Clearance Requirements for Airflow and Hardware Maintenance for the EX4100-F-24T Switch

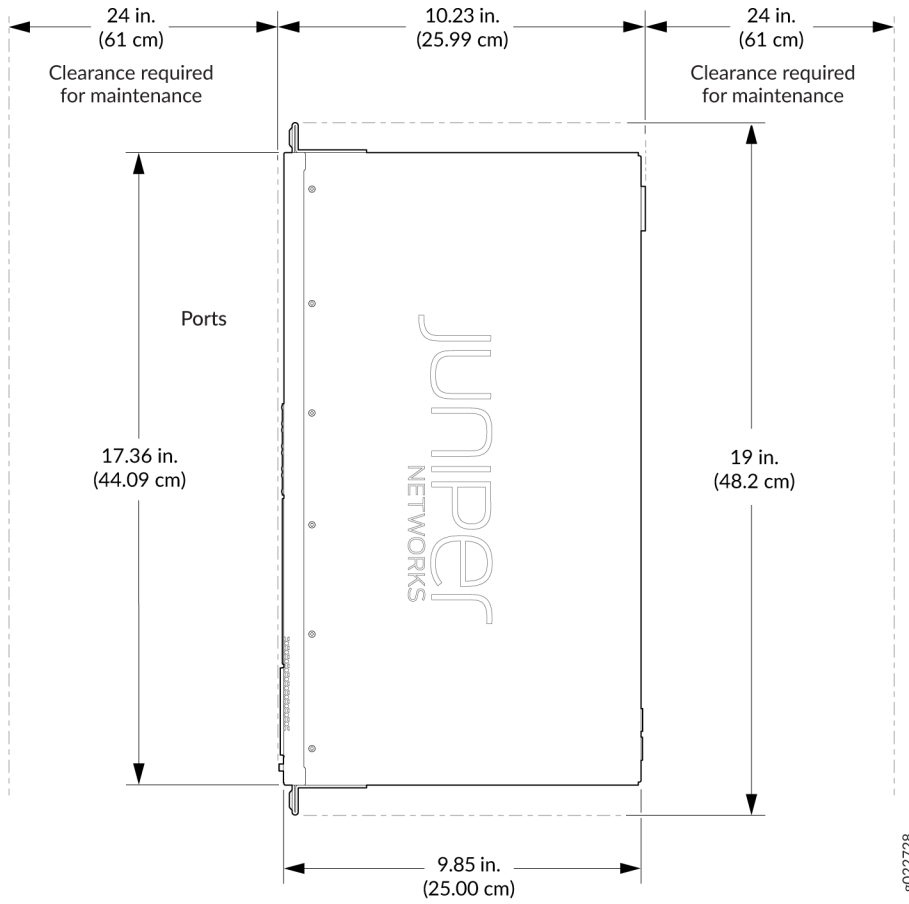

Figure 50: Clearance Requirements for Airflow and Hardware Maintenance for the EX4100-F-24P Switch

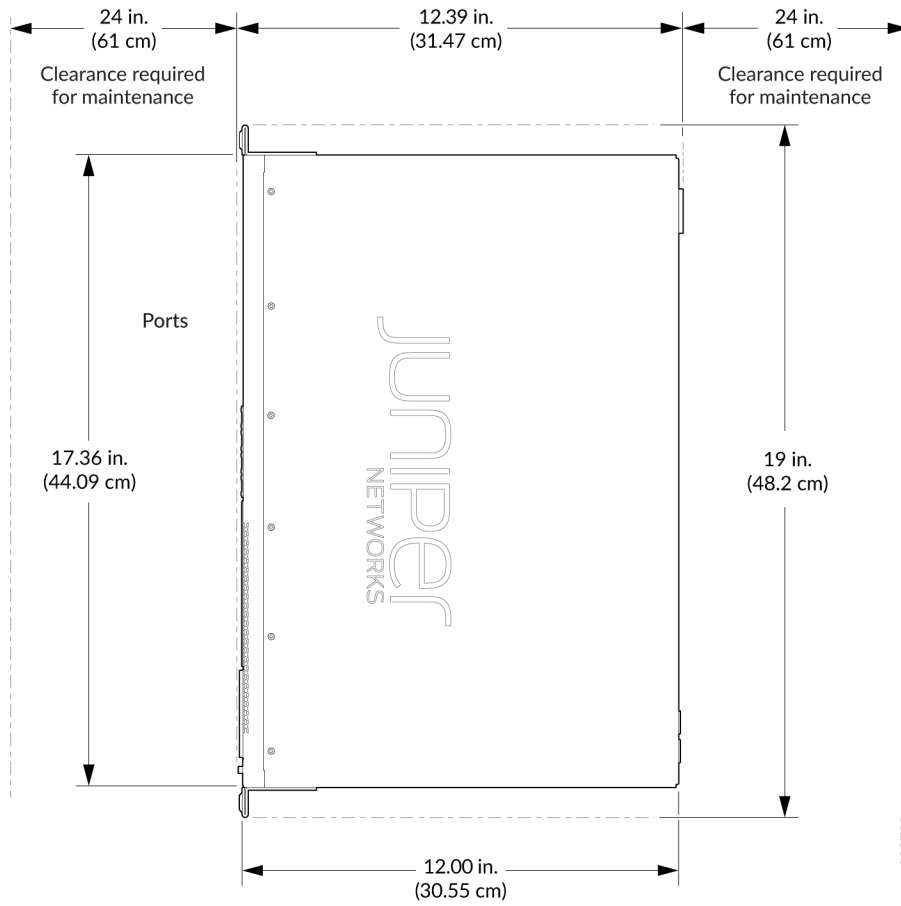

Figure 51: Clearance Requirements for Airflow and Hardware Maintenance for the EX4100-F-48P Switch

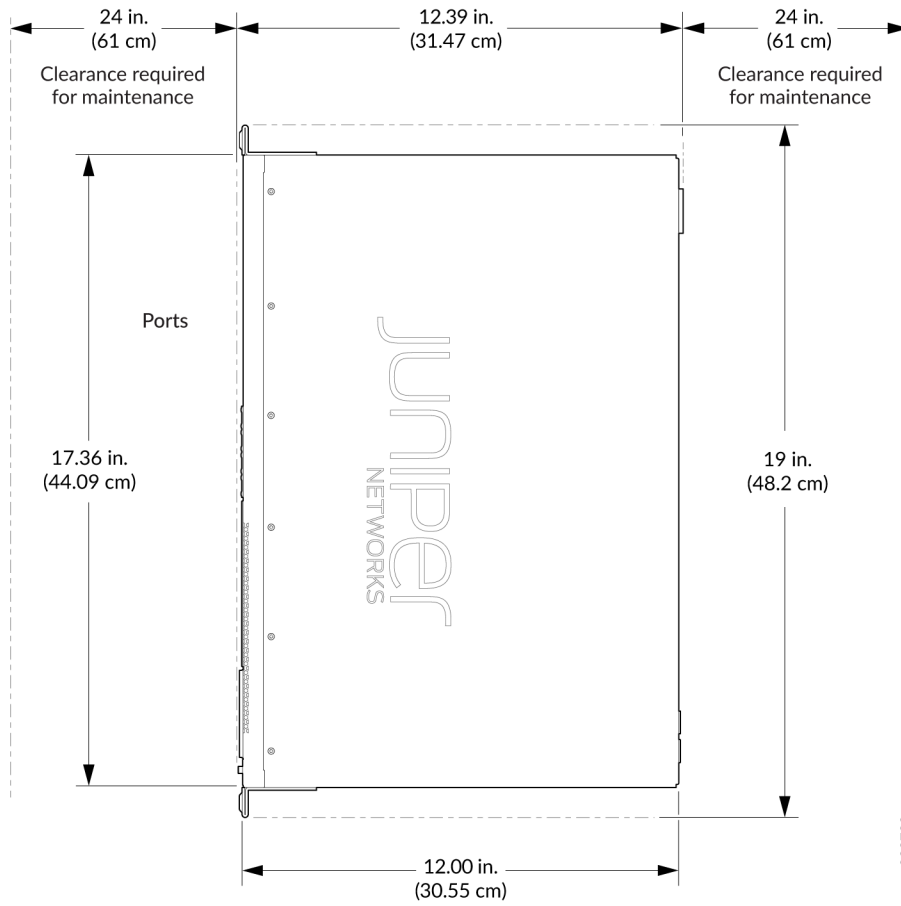
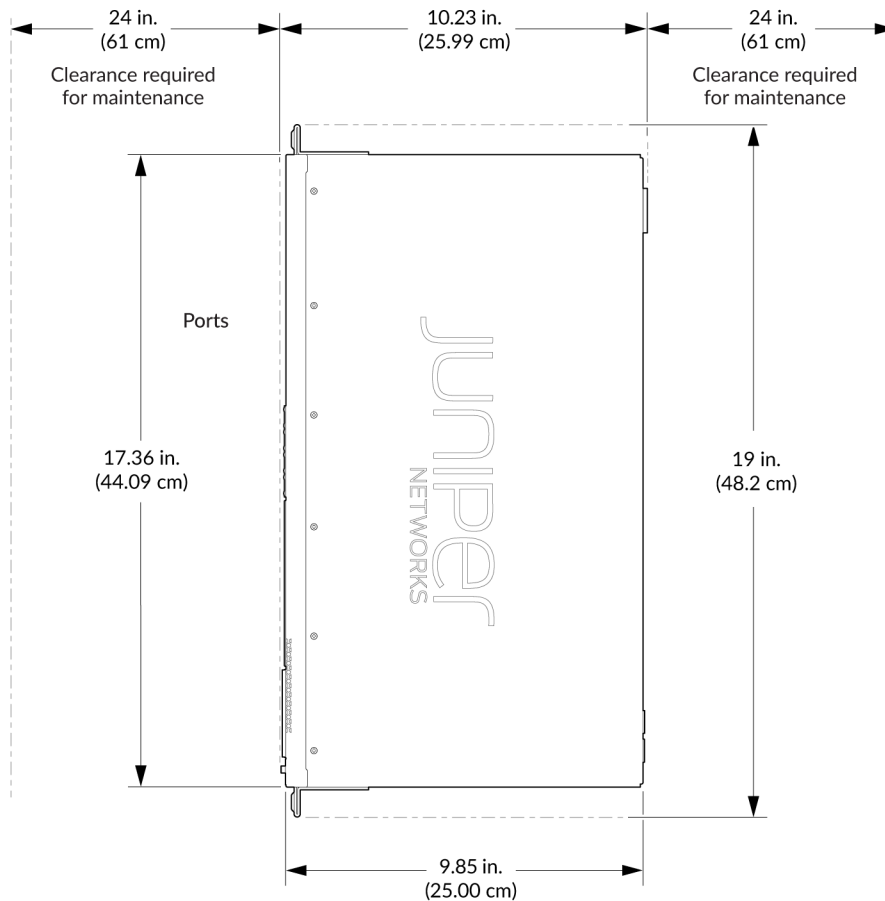

Figure 52: Clearance Requirements for Airflow and Hardware Maintenance for the EX4100-F-48T Switch



- For the cooling system to function properly, the airflow around the chassis must be unrestricted.
- If you are mounting the switch in a rack or cabinet with other equipment, or if you are placing it on the desktop or floor near other equipment, ensure that the exhaust from other equipment does not blow into the intake vents of the chassis.
- Leave at least 24 in. (61 cm) in front of the switch and behind the switch. For service personnel to remove and install hardware components, you must leave adequate space at the front and back of the switch. It is recommended that you allow at least 30 in. (76.2 cm) in front of the rack or cabinet and 24 in. (61 cm) behind the rack or cabinet.

EX4100-F Network Cable and Transceiver Planning

IN THIS SECTION

- [Pluggable Transceivers and Cables Supported on EX4100-F Switches | 78](#)
- [SFP+ Direct Attach Copper Cables for EX Series Switches | 79](#)
- [Overview of EX Series Switches: Fiber-Optic Cable Signal Loss, Attenuation, and Dispersion | 81](#)
- [Calculate the Fiber-Optic Cable Power Budget for EX Series Devices | 83](#)
- [Calculating the Fiber-Optic Cable Power Margin for EX Series Devices | 84](#)

Pluggable Transceivers and Cables Supported on EX4100-F Switches

The [Hardware Compatibility Tool](#) lists the transceivers that EX4100-F switches support and provides general information about those transceivers.

NOTE: We recommend that you use only optical transceivers and optical connectors purchased from Juniper Networks with your Juniper Networks device.



CAUTION: The Juniper Networks Technical Assistance Center (JTAC) provides complete support for Juniper-supplied optical modules and cables. However, JTAC does not provide support for third-party optical modules and cables that are not qualified or supplied by Juniper Networks. If you face a problem running a Juniper device that uses third-party optical modules or cables, JTAC may help you diagnose host-related issues if the observed issue is not, in the opinion of JTAC, related to the use of the third-party optical modules or cables. Your JTAC engineer will likely request that you check the third-party optical module or cable and, if required, replace it with an equivalent Juniper-qualified component.

Use of third-party optical modules with high-power consumption (for example, coherent ZR or ZR+) can potentially cause thermal damage to or reduce the lifespan of the host equipment. Any damage to the host equipment due to the use of third-party optical modules or cables is the users' responsibility. Juniper Networks will accept no liability for any damage caused due to such use.

The Gigabit Ethernet (GbE) transceivers installed in EX4100-F switches support digital optical monitoring (DOM). You can view the diagnostic details for these transceivers by issuing the operational mode CLI command `show interfaces diagnostics optics` .

NOTE: The transceivers support DOM even if you install the transceivers in ports that you configured as Virtual Chassis ports (VCPs).

SFP+ Direct Attach Copper Cables for EX Series Switches

IN THIS SECTION

- [Cable Specifications | 80](#)
- [List of DAC Cables Supported on EX Series Switches | 80](#)
- [Standards Supported by These Cables | 81](#)

Small form-factor pluggable plus transceiver (SFP+) direct attach copper (DAC) cables, also known as Twinax cables, are suitable for in-rack connections between servers and switches. They are suitable for short distances, making them ideal for highly cost-effective networking connectivity within a rack and between adjacent racks.

NOTE: We recommend that you use only SFP+ DAC cables purchased from Juniper Networks with your Juniper Networks device.



CAUTION: The Juniper Networks Technical Assistance Center (JTAC) provides complete support for Juniper-supplied optical modules and cables. However, JTAC does not provide support for third-party optical modules and cables that are not qualified or supplied by Juniper Networks. If you face a problem running a Juniper device that uses third-party optical modules or cables, JTAC may help you diagnose host-related issues if the observed issue is not, in the opinion of JTAC, related to the use of the third-party optical modules or cables. Your JTAC engineer will likely request that you check the

third-party optical module or cable and, if required, replace it with an equivalent Juniper-qualified component.

Use of third-party optical modules with high-power consumption (for example, coherent ZR or ZR+) can potentially cause thermal damage to or reduce the lifespan of the host equipment. Any damage to the host equipment due to the use of third-party optical modules or cables is the users' responsibility. Juniper Networks will accept no liability for any damage caused due to such use.

Cable Specifications

EX Series switches support SFP+ passive DAC cables. The passive Twinax cable is a straight cable with no active electronic components. EX Series switches support 1 m, 3 m, 5 m, and 7 m long SFP+ passive DAC cables. See [Figure 53 on page 80](#).

Figure 53: SFP+ Direct Attach Copper Cables for EX Series Switches

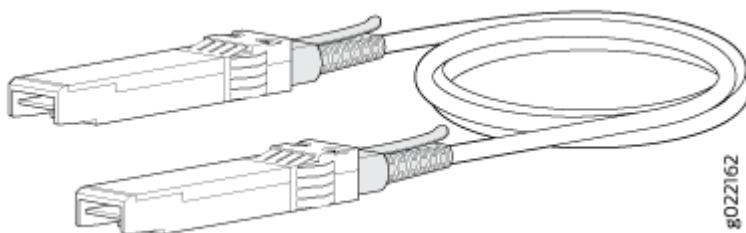

The cables are hot-removable and hot-insertable: You can remove and replace them without powering off the switch or disrupting switch functions. A cable comprises a low-voltage cable assembly that connects directly into two 10-Gigabit Ethernet (GbE) ports, one at each end of the cable. The cables use high-performance integrated duplex serial data links for bidirectional communication and are designed for data rates of up to 10 Gbps.

List of DAC Cables Supported on EX Series Switches

For the list of DAC cables supported on EX Series switches and the specifications of these cables, see the following references:

- EX2300—[Hardware Compatibility Tool page for EX2300](#)
- EX3200—[Hardware Compatibility Tool page for EX3200](#)
- EX3300—[Hardware Compatibility Tool page for EX3300](#)
- EX3400—[Hardware Compatibility Tool page for EX3400](#)

- EX4100 –[Hardware Compatibility Tool for EX4100](#)
- EX4100-F –[Hardware Compatibility Tool for EX4100-F](#)
- EX4100-H
- EX4200–[Hardware Compatibility Tool page for EX4200](#)
- EX4300–[Hardware Compatibility Tool page for EX4300](#)
- EX4400–[Hardware Compatibility Tool page for EX4400](#)
- EX4500–[Hardware Compatibility Tool page for EX4500](#)
- EX4550–[Hardware Compatibility Tool page for EX4550](#)
- EX4600–[Hardware Compatibility Tool page for EX4600](#)
- EX8208–[Hardware Compatibility Tool page for EX8208](#)
- EX8216–[Hardware Compatibility Tool page for EX8216](#)
- EX9251–[Hardware Compatibility Tool page for EX9251](#)
- EX9253–[Hardware Compatibility Tool page for EX9253](#)

Standards Supported by These Cables

The cables comply with the following standards:

- SFP mechanical standard SFF-843– see <ftp://ftp.seagate.com/sff/SFF-8431.PDF>.
- Electrical interface standard SFF-8432– see <ftp://ftp.seagate.com/sff/SFF-8432.PDF>.
- SFP+ Multi-Source Alliance (MSA) standards

Overview of EX Series Switches: Fiber-Optic Cable Signal Loss, Attenuation, and Dispersion

IN THIS SECTION

-  Signal Loss in Multimode and Single-Mode Fiber-Optic Cable | 82

To determine the power budget and power margin needed for fiber-optic connections, you need to understand how signal loss, attenuation, and dispersion affect transmission. EX Series switches use various types of network cables, including multimode and single-mode fiber-optic cable.

Signal Loss in Multimode and Single-Mode Fiber-Optic Cable

Multimode fiber is large enough in diameter to allow rays of light to reflect internally (bounce off the walls of the fiber). Interfaces with multimode optics typically use LEDs as light sources. However, LEDs are not coherent light sources. They spray varying wavelengths of light into the multimode fiber, which reflects the light at different angles. Light rays travel in jagged lines through a multimode fiber, causing signal dispersion. When light traveling in the fiber core radiates into the fiber, higher-order mode loss (HOL) occurs. (Cladding consists of layers of lower-refractive index material in close contact with a core material of higher refractive index.) Together, these factors reduce the transmission distance of multimode fiber compared to that of single-mode fiber.

Single-mode fiber is so small in diameter that rays of light reflect internally through one layer only. Interfaces with single-mode optics use lasers as light sources. Lasers generate a single wavelength of light, which travels in a straight line through the single-mode fiber. Compared to multimode fiber, single-mode fiber has a higher bandwidth and can carry signals for longer distances. Single-mode fiber is consequently more expensive than multimode fiber.

Exceeding the maximum transmission distances can result in significant signal loss, which causes unreliable transmission.

Attenuation and Dispersion in Fiber-Optic Cable

An optical data link functions correctly provided that modulated light reaching the receiver has enough power to be demodulated correctly. *Attenuation* is the reduction in strength of the light signal during transmission. Passive media components such as cables, cable splices, and connectors cause attenuation. Although attenuation is significantly lower for optical fiber than for other media, it still occurs in both multimode and single-mode transmissions. An efficient optical data link must transmit enough light to overcome attenuation.

Dispersion is the spreading of the signal over time. The following two types of dispersion can affect signal transmission through an optical data link:

- Chromatic dispersion, which is the spreading of the signal over time caused by the different speeds of light rays

- Modal dispersion, which is the spreading of the signal over time caused by the different propagation modes in the fiber

For multimode transmission, modal dispersion usually limits the maximum bit rate and link length. Chromatic dispersion or attenuation is not a factor.

For single-mode transmission, modal dispersion is not a factor. However, at higher bit rates and over longer distances, chromatic dispersion limits the maximum link length.

An efficient optical data link must have enough light to exceed the minimum power that the receiver requires to operate within its specifications. In addition, the total dispersion must be within the limits specified for the type of link in Telcordia Technologies document GR-253-CORE (Section 4.3) and International Telecommunications Union (ITU) document G.957.

When chromatic dispersion is at the maximum allowed, you can consider its effect as a power penalty in the power budget. The optical power budget must allow for the sum of component attenuation, power penalties (including those from dispersion), and a safety margin for unexpected power loss.

Calculate the Fiber-Optic Cable Power Budget for EX Series Devices

To ensure that fiber-optic connections have sufficient power for correct operation, calculate the link's power budget when planning fiber-optic cable layout and distances. This planning helps you ensure that fiber-optic connections have sufficient power for correct operation. The power budget is the maximum amount of power the link can transmit. When you calculate the power budget, you use a worst-case analysis to provide a margin of error. You use a worst-case analysis even though not all the parts of an actual system operate at the worst-case levels.

To calculate the worst-case estimate for a fiber-optic cable power budget (P_B) for the link:

1. Determine values for the link's minimum transmitter power (P_T) and minimum receiver sensitivity (P_R). In the following example, we measure both (P_T) and (P_R) in decibels relative to one milliwatt (dBm).

$$P_T = -15 \text{ dBm}$$

$$P_R = -28 \text{ dBm}$$

NOTE: See the specifications for your transmitter and receiver to find the minimum transmitter power and minimum receiver sensitivity.

2. Calculate the power budget (P_B) by subtracting (P_R) from (P_T):

$$-15 \text{ dBm} - (-28 \text{ dBm}) = 13 \text{ dBm}$$

Calculating the Fiber-Optic Cable Power Margin for EX Series Devices

Before calculating the power margin, calculate the power budget (see *Calculating the Fiber-Optic Cable Power Budget for EX Series Devices*).

Calculate the link's power margin when planning fiber-optic cable layout and distances to ensure that fiber-optic connections have sufficient signal power to overcome system loss and still satisfy the minimum input requirements of the receiver for the required performance level. The power margin (P_M) is the amount of power available after you subtract attenuation or link loss (LL) from the power budget (P_B).

When you calculate the power margin, you use a worst-case analysis to provide a margin of error, even though not all parts of an actual system operate at worst-case levels. A power margin (P_M) greater than zero indicates that the power budget is sufficient to operate the receiver and that it does not exceed the maximum receiver input power. This means that the link will work. A (P_M) that is zero or negative indicates insufficient power to operate the receiver. See the specification for your receiver to find the maximum receiver input power.

To calculate the worst-case estimate for the power margin (P_M) for the link:

1. Determine the maximum value for link loss (LL) by adding estimated values for applicable link-loss factors—for example, use the sample values for various factors as provided in [Table 35 on page 84](#) (here, the link is 2 km long and multimode, and the (P_B) is 13 dBm):

Table 35: Estimated Values for Factors Causing Link Loss

Link-Loss Factor	Estimated Link-Loss Value	Sample (LL) Calculation Values
Higher-order mode losses (HOL)	<ul style="list-style-type: none"> • Multimode—0.5 dBm • Single mode—None 	<ul style="list-style-type: none"> • 0.5 dBm • 0 dBm
Modal and chromatic dispersion	<ul style="list-style-type: none"> • Multimode—None, if product of bandwidth and distance is less than 500 MHz/km • Single mode—None 	<ul style="list-style-type: none"> • 0 dBm • 0 dBm
Connector	0.5 dBm	<p>This example assumes 5 connectors. Loss for 5 connectors:</p> <p>(5) * (0.5 dBm) = 2.5 dBm</p>

Table 35: Estimated Values for Factors Causing Link Loss (*Continued*)

Link-Loss Factor	Estimated Link-Loss Value	Sample (LL) Calculation Values
Splice	0.5 dBm	This example assumes 2 splices. Loss for two splices: $(2) * (0.5 \text{ dBm}) = 1 \text{ dBm}$
Fiber attenuation	<ul style="list-style-type: none"> • Multimode—1 dBm/km • Single mode—0.5 dBm/km 	This example assumes the link is 2 km long. Fiber attenuation for 2 km: <ul style="list-style-type: none"> • $(2 \text{ km}) * (1.0 \text{ dBm/km}) = 2 \text{ dBm}$ • $(2 \text{ km}) * (0.5 \text{ dBm/km}) = 1 \text{ dBm}$
Clock Recovery Module (CRM)	1 dBm	1 dBm

NOTE: For information about the actual amount of signal loss caused by equipment and other factors, see your vendor documentation for that equipment.

2. Calculate the (P_M) by subtracting (LL) from (P_B):

$$P_B - LL = P_M$$

$$(13 \text{ dBm}) - (0.5 \text{ dBm [HOL]}) - ((5) * (0.5 \text{ dBm})) - ((2) * (0.5 \text{ dBm})) - ((2 \text{ km}) * (1.0 \text{ dBm/km})) - (1 \text{ dB [CRM]}) = P_M$$

$$13 \text{ dBm} - 0.5 \text{ dBm} - 2.5 \text{ dBm} - 1 \text{ dBm} - 2 \text{ dBm} - 1 \text{ dBm} = P_M$$

$$P_M = 6 \text{ dBm}$$

The calculated power margin is greater than zero, indicating that the link has sufficient power for transmission. Also, the power margin value does not exceed the maximum receiver input power. Refer to the specification for your receiver to find the maximum receiver input power.

EX4100-F Management Cable Specifications and Pinouts

IN THIS SECTION

- Management Cable Specifications | 86
- Console Port Connector Pinout Information | 87
- USB Port Specifications for an EX Series Switch | 88
- RJ-45 Management Port Connector Pinout Information | 89
- RJ-45 Port, SFP Port, and SFP+ Port Connector Pinouts | 90
- RJ-45 to DB-9 Serial Port Adapter Pinout Information | 94

Management Cable Specifications

Table 36 on page 86 lists the specifications for the cables that connect the console and management ports to management devices.

Table 36: Specifications of Cables to Connect to Management Devices

Ports	Cable Specifications	Receptacle	Additional Information
RJ-45 Console port	CAT5e UTP (unshielded twisted pair) cable	RJ-45	<i>Connect a Device to a Management Console Using an RJ-45 Connector</i>
Management Ethernet port	Ethernet cable with an RJ-45 connector	RJ-45	<i>Connect a Device to a Network for Out-of-Band Management</i>

Table 36: Specifications of Cables to Connect to Management Devices (Continued)

Ports	Cable Specifications	Receptacle	Additional Information
USB-C Console port	Mini-USB cable with standard-A and USB-C (5-pin) connector	Mini-USB	

Console Port Connector Pinout Information

The console port on a Juniper Networks device is an RS-232 serial interface that uses an RJ-45 connector to connect to a console management device. The default baud rate for the console port is 9600 baud.

Table 37 on page 88 provides the pinout information for the RJ-45 console connector.

NOTE: We no longer include the RJ-45 console cable with the DB-9 adapter as part of the device package. If the console cable and adapter are not included in your device package, or if you need a different type of adapter, you can order the following separately:

- RJ-45 to DB-9 adapter (JNP-CBL-RJ45-DB9)
- RJ-45 to USB-A adapter (JNP-CBL-RJ45-USBA)
- RJ-45 to USB-C adapter (JNP-CBL-RJ45-USBC)

If you want to use RJ-45 to USB-A or RJ-45 to USB-C adapter you must have X64 (64-Bit) Virtual COM port (VCP) driver installed on your PC. See, <https://ftdichip.com/drivers/vcp-drivers/> to download the driver.

NOTE: If your laptop or desktop PC does not have a DB-9 plug connector pin and you want to connect your laptop or desktop PC directly to a device, use a combination of the RJ-45-to-DB-9 socket adapter and a USB-to-DB-9 plug adapter. You must provide the USB-to-DB-9 plug adapter.

Table 37: Console Port Connector Pinout Information

Pin	Signal	Description
1	NC	No connect
2	NC	No connect
3	TxD Output	Transmit data
4	GND	Signal ground
5	GND	Signal ground
6	RxD Input	Receive data
7	DCD Input	Data carrier detect
8	NC	No connect

USB Port Specifications for an EX Series Switch

Juniper Networks tested and officially supports the following USB flash drives for the USB port on all EX Series switches:

- RE-USB-1G-S
- RE-USB-2G-S
- RE-USB-4G-S



CAUTION: Any USB memory product not listed as supported for EX Series switches has not been tested by Juniper Networks. The use of any unsupported USB memory product could expose your EX Series switch to unpredictable behavior. Juniper Networks Technical Assistance Center (JTAC) can provide only limited support for

issues related to unsupported hardware. We strongly recommend that you use only supported USB flash drives.

All USB flash drives used on EX Series switches must have the following features:

- USB 2.0 or later.
- Formatted with a FAT or MS-DOS file system.
- If the switch is running Junos OS Release 9.5 or earlier, the formatting method must use a primary boot record. Microsoft Windows formatting, by default, does not use a primary boot record. See the documentation for your USB flash drive for information about how your USB flash drive is formatted.

RJ-45 Management Port Connector Pinout Information

[Table 38 on page 89](#) provides the pinout information for the RJ-45 connector for the management port on Juniper Networks devices.

Table 38: RJ-45 Management Port Connector Pinout Information

Pin	Signal	Description
1	TRP1+	Transmit/receive data pair 1
2	TRP1-	Transmit/receive data pair 1
3	TRP2+	Transmit/receive data pair 2
4	TRP3+	Transmit/receive data pair 3
5	TRP3-	Transmit/receive data pair 3
6	TRP2-	Transmit/receive data pair 2
7	TRP4+	Transmit/receive data pair 4

Table 38: RJ-45 Management Port Connector Pinout Information (Continued)

Pin	Signal	Description
8	TRP4-	Transmit/receive data pair 4

RJ-45 Port, SFP Port, and SFP+ Port Connector Pinouts

The following tables describe the connector pinout information for the RJ-45, SFP+, and SFP ports:

- [Table 39 on page 90](#) for 10/100/1000BASE-T Ethernet Network Port Connector Pinout Information.
- [Table 40 on page 91](#) for SFP Network Port Connector Pinout Information.
- [Table 41 on page 92](#) for SFP+ Network Port Connector Pinout Information.

Table 39: 10/100/1000BASE-T Ethernet Network Port Connector Pinout Information

Pin	Signal	Description
1	TRP1+	Transmit/receive data pair 1 Negative Vport (in PoE models)
2	TRP1-	Transmit/receive data pair 1 Negative Vport (in PoE models)
3	TRP2+	Transmit/receive data pair 2 Positive Vport (in PoE models)
4	TRP3+	Transmit/receive data pair 3
5	TRP3-	Transmit/receive data pair 3

Table 39: 10/100/1000BASE-T Ethernet Network Port Connector Pinout Information (Continued)

Pin	Signal	Description
6	TRP2-	Transmit/receive data pair 2 Positive Vport (in PoE models)
7	TRP4+	Transmit/receive data pair 4
8	TRP4-	Transmit/receive data pair 4

Table 40: SFP Network Port Connector Pinout Information

Pin	Signal	Description
1	VeeT	Module transmitter ground
2	TX_Fault	Module transmitter fault
3	TX_Disable	Transmitter disabled
4	SDA	2-wire serial interface data line
5	SCL-	2-wire serial interface clock
6	MOD_ABS	Module absent
7	RS	Rate select
8	RX_LOS	Receiver loss of signal indication
9	VeeR	Module receiver ground
10	VeeR	Module receiver ground

Table 40: SFP Network Port Connector Pinout Information (Continued)

Pin	Signal	Description
11	VeeR	Module receiver ground
12	RD-	Receiver inverted data output
13	RD+	Receiver noninverted data output
14	VeeR	Module receiver ground
15	VccR	Module receiver 3.3 V supply
16	VccT	Module transmitter 3.3 V supply
17	VeeT	Module transmitter ground
18	TD+	Transmitter noninverted data input
19	TD-	Transmitter inverted data input
20	VeeT	Module transmitter ground

Table 41: SFP+ Network Port Connector Pinout Information

Pin	Signal	Description
1	VeeT	Module transmitter ground
2	TX_Fault	Module transmitter fault
3	TX_Disable	Transmitter disabled
4	SDA	2-wire serial interface data line

Table 41: SFP+ Network Port Connector Pinout Information (Continued)

Pin	Signal	Description
5	SCL-	2-wire serial interface clock
6	MOD_ABS	Module absent
7	RS0	Rate select 0, optionally controls SFP+ module receiver
8	RX_LOS	Receiver loss of signal indication
9	RS1	Rate select 1, optionally controls SFP+ transmitter
10	VeeR	Module receiver ground
11	VeeR	Module receiver ground
12	RD-	Receiver inverted data output
13	RD+	Receiver noninverted data output
14	VeeR	Module receiver ground
15	VccR	Module receiver 3.3-V supply
16	VccT	Module transmitter 3.3-V supply
17	VeeT	Module transmitter ground
18	TD+	Transmitter noninverted data input
19	TD-	Transmitter inverted data input

Table 41: SFP+ Network Port Connector Pinout Information (Continued)

Pin	Signal	Description
20	VeeT	Module transmitter ground

RJ-45 to DB-9 Serial Port Adapter Pinout Information

The console port on a Juniper Networks device is an RS-232 serial interface that uses an RJ-45 connector to connect to a management device such as a laptop or a desktop PC. If your laptop or desktop PC does not have a DB-9 plug connector pin and you want to connect your laptop or desktop PC to the device, use a combination of the RJ-45 to DB-9 socket adapter along with a USB to DB-9 plug adapter.

[Table 42 on page 94](#) provides the pinout information for the RJ-45 to DB-9 serial port adapter.

Table 42: RJ-45 to DB-9 Serial Port Adapter Pinout Information

RJ-45 pin	Signal	DB-9 pin	Signal
1	NC	8	CTS
2	NC	6	DSR
3	TxD	2	RxD
4	GND	5	GND
6	RxD	3	TxD
7	DCD	4	DTR
8	NC	7	RTS

4

CHAPTER

Initial Installation and Configuration

[Install the EX4100-F Switch | 96](#)

[Connect the EX4100-F to Power | 139](#)

[Connect the EX4100-F Switch to External Devices | 147](#)

[Connect the EX4100-F Switch to the Network | 151](#)

[Configure Junos OS on an EX4100-F Switch | 156](#)

Install the EX4100-F Switch

SUMMARY

This topic guides you through the steps to install the EX4100-F switches.

IN THIS SECTION

- [Unpack the EX4100-F Switch | 97](#)
- [Packing List for an EX4100-F Switch | 97](#)
- [Register Products—Mandatory to Validate SLAs | 99](#)
- [Mount an EX4100-F Switch on Two Posts in a Rack or Cabinet | 100](#)
- [Mount an EX4100-F Switch on Four Posts in a Rack or Cabinet | 102](#)
- [Mount an EX4100-F Switch in a Recessed Position in a Rack or Cabinet | 106](#)
- [Mount an EX4100-F Switch on a Wall | 109](#)
- [Mounting an EX4100-F-12P and EX4100-F-12T switch | 112](#)
- [Mounting an EX4100-F-12P and EX4100-F-12T Switch on a Desk | 113](#)
- [Mounting an EX4100-F-12P and EX4100-F-12T Switch Under a Desk or Other Level Surface | 114](#)
- [Mounting an EX4100-F-12P and EX4100-F-12T Switch on Two Posts of a Rack | 118](#)
- [Mounting an EX4100-F-12P and EX4100-F-12T Switch on a Wall | 121](#)
- [Mounting an EX4100-F-12P and EX4100-F-12T Switch on a Ferrous Wall using Magnet Pads | 125](#)
- [Mounting an EX4100-12P and EX4100-12T Switch on a DIN Rail | 129](#)
- [Unmounting an EX4100-F-12P and EX4100-F-12T Switch From a DIN Rail | 132](#)
- [Common Instructions for EX4100-F-12P and EX4100-F-12T Mounting Options | 134](#)

- [Attaching the Power Adaptor to the Power Adaptor Tray | 135](#)
- [Attaching the Power Adaptor Tray to the Switch Chassis | 137](#)
- [Attaching the Cable Guard to Protect Cable Connections | 137](#)
- [Attaching the Standard Cable Lock to the Security Slot of the Switch | 139](#)

Unpack the EX4100-F Switch

Juniper Networks ships EX4100-F switches in a cardboard carton, secured with foam packing material. The carton has an accessory compartment.



CAUTION: The shipping carton completely protects the EX4100-F switches. Leave the switches safely in the carton until you are ready to begin installation.

To unpack the switch:

1. Move the shipping carton to a staging area as close to the installation site as possible, but where you have enough room to remove the system components.
2. Position the carton so that the arrows are pointing up.
3. Open the top flaps on the shipping carton.
4. Pull out the packing material holding the switch in place.
5. Verify the parts received against the inventory on the label attached to the carton (see ["Packing List for an EX4100-F Switch" on page 97](#)).
6. Save the shipping carton and packing materials in case you need to move or ship the switch later.

Packing List for an EX4100-F Switch

The switch shipment includes a packing list. Check the parts you receive with the switch against the items on the packing list. The packing list specifies the part number and provides a description of each part in your order. The parts shipped match the switch model you ordered (see No Link Title).

If any part on the packing list is missing, contact your customer service representative or contact Juniper customer care from within the U.S. or Canada by telephone at 1-888-314-5822. For international-dial or direct-dial options in countries without toll-free numbers, see <https://www.juniper.net/support/requesting-support.html>.

See:

- [Table 43 on page 98](#) for inventory of components provided with EX4100-F-12P and EX4100-F-12T models.
- [Table 44 on page 98](#) for inventory of components provided with EX4100-F-24P, EX4100-F-24T, EX4100-F-48P, and EX4100-F-48T models.

Table 43: Inventory of Components Provided with EX4100-F-12P and EX4100-F-12T models

Component	Quantity
Switch	1
Power Adaptor	1
AC power cord appropriate for your geographical location	1
Dust covers for SFP ports	8 preinstalled
Documentation Roadmap/Warranty Card	1
Juniper Networks Product Warranty	1
End User License Agreement	1

Table 44: Inventory of Components Provided with EX4100-F-24P, EX4100-F-24T, EX4100-F-48P, and EX4100-F-48T models

Component	Quantity
Switch with in-built fans and power supply	1

Table 44: Inventory of Components Provided with EX4100-F-24P, EX4100-F-24T, EX4100-F-48P, and EX4100-F-48T models (Continued)

Component	Quantity
AC power cord appropriate for your geographical location	1
AC power cord retainer	1
Dust covers for SFP ports	8 preinstalled
Mounting brackets (2-post)	2
Rubber feet	4
Documentation Roadmap/Warranty Card	1
Juniper Networks Product Warranty	1
End User License Agreement	1

Register Products—Mandatory to Validate SLAs

Register all new Juniper Networks hardware products and changes to an existing installed product using the Juniper Networks website to activate your hardware replacement service-level agreements (SLAs).



CAUTION: Register product serial numbers on the Juniper Networks website. Update the installation base data if any addition or change to the installation base occurs or if the installation base is moved. Juniper Networks is not responsible for not meeting the hardware replacement service-level agreement for products that do not have registered serial numbers or accurate installation base data.

Register your product(s) at <https://tools.juniper.net/svcreg/SRegSerialNum.jsp>.

Update your installation base at <https://www.juniper.net/customers/csc/management/updateinstallbase.jsp>.

Mount an EX4100-F Switch on Two Posts in a Rack or Cabinet

Before mounting the switch on two posts in a rack:

- Verify that the site meets the requirements described in Environmental Requirements and Specifications for EX4100 and EX4100-F Switches.
- Place the rack in its permanent location, allowing adequate clearance for airflow and maintenance, and secure it to the building structure.
- Read [General Safety Guidelines and Warnings](#), with particular attention to [Chassis and Component Lifting Guidelines](#).

Ensure that you have the following parts and tools available:

- Phillips (+) screwdriver, number 2 (not provided).
- Screws to secure the chassis to the rack (not provided).
- 2-in.-recess front-mounting brackets (from the separately orderable four-post rack-mounting kit) if you will mount the switch in a recessed position.

You can mount an EX4100-F switch on two posts of a 19-in. rack or cabinet by using the front mounting brackets provided with the switch. (The remainder of this topic uses *rack* to mean *rack or cabinet*.)

You can mount the switch on four posts of a four-post rack by using the mounting brackets provided with the separately orderable four-post rack-mounting kit. See "[Mount an EX4100-F Switch on Four Posts in a Rack or Cabinet](#)" on page 102.

NOTE: If you need to mount the switch in a recessed position on either a two-post rack or a four-post rack, you can use the 2-in.-recess front-mounting brackets provided in the separately orderable four-post rack-mounting kit.

NOTE: One person must be available to lift the switch while another secures the switch to the rack.



CAUTION: If you are mounting multiple units on a rack, mount the heaviest unit at the bottom of the rack and mount the other units from the bottom of the rack to the top in decreasing order of the weight of the units.

To mount the switch on two posts in a rack:

1. Remove the switch from the shipping carton (see ["Unpack the EX4100-F Switch" on page 97](#)).

Figure 54: EX4100-F Chassis with Front-Mounting Brackets

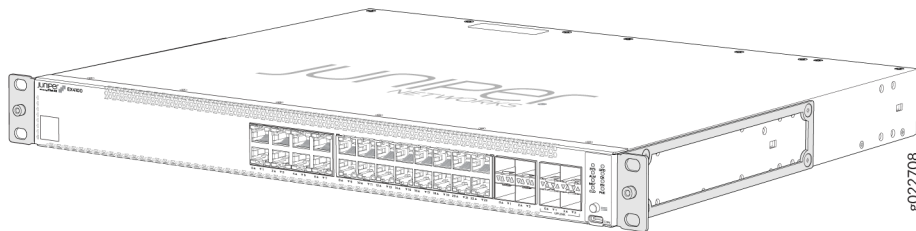

2. Place the switch on a flat, stable surface.
3. The front brackets allow you to mount the switch. If you want to mount the switch in a recessed position, attach the 2-in.-recessed front-mounting brackets provided in the separately orderable four-post rack-mounting kit.
4. Have one person grasp both sides of the switch, lift the switch, and position it in the rack, aligning the mounting bracket holes with the threaded holes in the rack or cabinet rail. Have the person align the bottom hole in each mounting bracket with a hole in each rack rail, making sure that the chassis is level. See [Figure 55 on page 102](#).

Figure 55: Mounting the Switch on Two Posts in a Rack

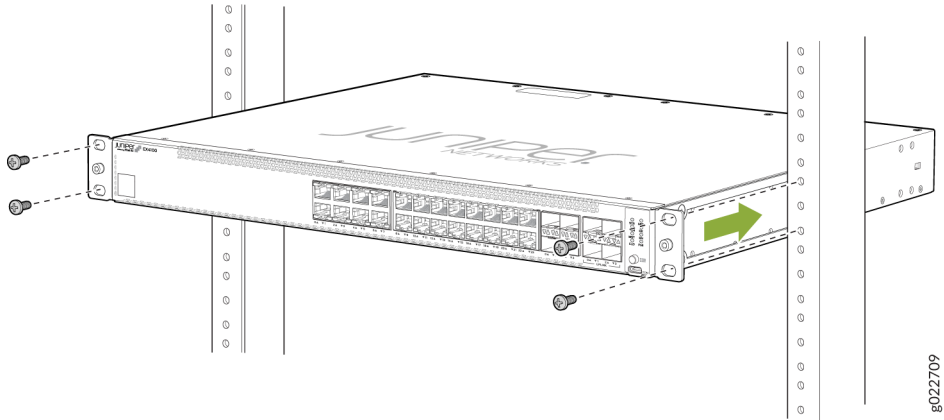

5. Have a second person secure the switch to the rack by using the appropriate screws. Tighten the screws.
6. Ensure that the switch chassis is level by verifying that all screws on one side of the rack are aligned with the screws on the other side.

Figure 56: EX4100-F Chassis Installed in Rack

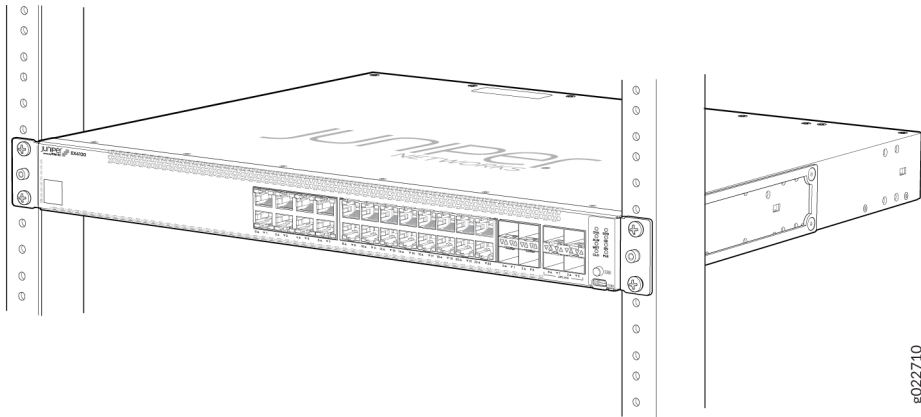

Mount an EX4100-F Switch on Four Posts in a Rack or Cabinet

Before mounting the switch on four posts in a rack:

- Verify that the site meets the requirements described in EX4100 and EX4100-F Site Guidelines and Requirements.
- Place the rack in its permanent location, allowing adequate clearance for airflow and maintenance, and secure it to the building structure.
- Read *General Safety Guidelines and Warnings*, with particular attention to *Chassis and Component Lifting Guidelines*.

Ensure that you have the following parts and tools available:

- Phillips (+) screwdriver, number 2
- 6 flat-head 4-40 mounting screws (provided with the four-post rack-mounting kit)
- 12 flat-head 4x6-mm Phillips mounting screws (provided with the four-post rack-mounting kit)
- One pair each of flush or 2-in.-recessed front-mounting brackets (provided with the four-post rack-mounting kit)
- One pair of side-mounting rails (provided with the four-post rack-mounting kit)
- One pair of rear-mounting blades (provided with the four-post rack-mounting kit)
- Screws to secure the chassis and the rear-mounting blades to the rack (not provided)

You can mount an EX4100-F switch on four posts of a 19-in. rack or cabinet by using the separately orderable four-post rack-mounting kit. (The remainder of this topic uses *rack* to mean *rack or cabinet*.)

NOTE: If you need to mount the switch in a recessed position on either a two-post rack or a four-post rack, you can use the 2-in.-recessed front-mounting brackets provided in the separately orderable four-post rack-mounting kit.

NOTE: One person must be available to lift the switch while another secures the switch to the rack.



CAUTION: If you are mounting multiple units on a rack, mount the heaviest unit at the bottom of the rack and mount the other units from the bottom of the rack to the top in decreasing order of the weight of the units.

To mount the switch on four posts in a rack:

1. Remove the switch from the shipping carton (see "[Unpack the EX4100-F Switch](#)" on page 97).

2. Place the switch on a flat, stable surface.
3. Attach the front-mounting brackets (either the flush or the 2-in.-recess front-mounting brackets) to the side mounting-rails by using the 6 4-40 flat-head Phillips mounting screws. See [Figure 57 on page 104](#).

Figure 57: Attaching the Front-Mounting Bracket to the Side Mounting-Rail

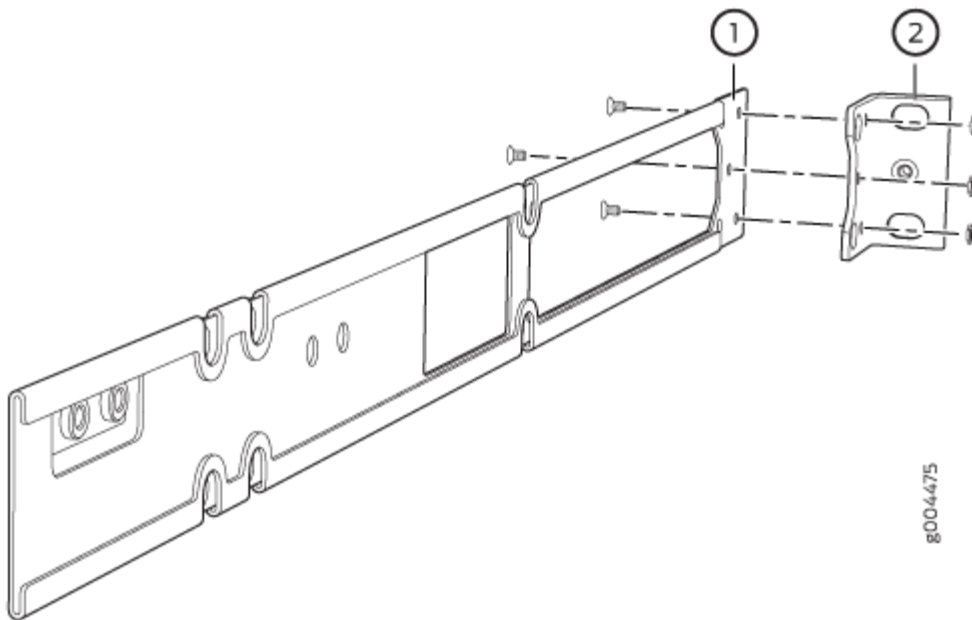

1- Side mounting rail

2- Front-mounting bracket

4. Align the side mounting rails along the side panels of the switch chassis. Align the two holes in the rear of the side mounting rails with the two holes on the rear of the side panel.
5. As shown in [Figure 58 on page 105](#), align the side mounting rails along the side panels of the switch chassis and insert and tighten the twelve 4x6 mm Phillips flat-head mounting screws to secure the side panels to the two sides of the switch chassis.

Figure 58: Attaching the Side Mounting Rail to the Switch Chassis

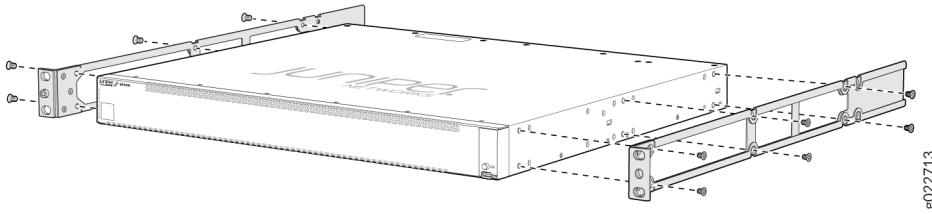

6. Have one person grasp both sides of the switch, lift the switch, and position it in the rack, aligning the holes on the side mounting rail with the threaded holes in the front post of the rack. Have the person align the bottom hole in both the front-mounting brackets with a hole in each rack rail, making sure that the chassis is level. See [Figure 59 on page 105](#).

Figure 59: Mounting the Switch to the Front Posts in a Rack

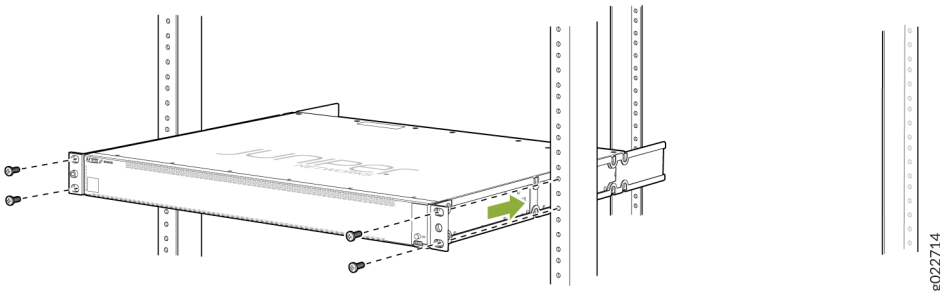

7. Have a second person secure the front of the switch to the rack by using the appropriate screws for your rack.
8. Slide the rear-mounting blades into the side mounting-rails. See [Figure 60 on page 105](#).

Figure 60: Sliding the Rear-Mounting Blades into the Side Mounting Rails

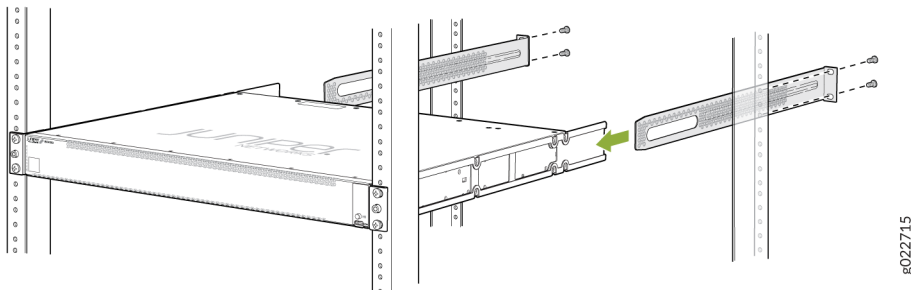

- Attach the rear-mounting blades to the rear post by using the appropriate screws for your rack. Tighten the screws.

Figure 61: Chassis Fully Installed in the Rack

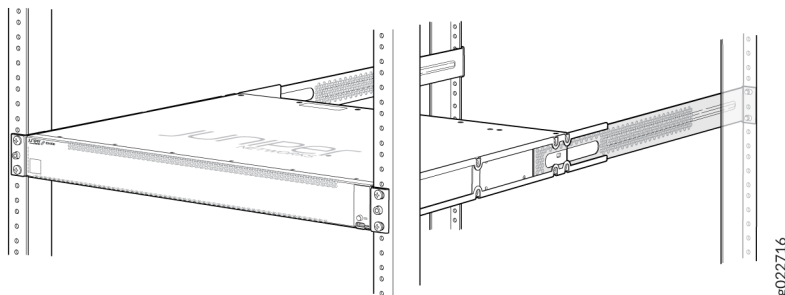

- Ensure that the switch chassis is level by verifying that all the screws on the front of the rack are aligned with the screws at the back of the rack.

Mount an EX4100-F Switch in a Recessed Position in a Rack or Cabinet

You can mount an EX4100-F switch in a rack or cabinet such that the switch is recessed inside the rack from the front of the rack by 2 inches. You can use the 2-in.-recessed front-mounting brackets provided in the separately orderable four-post rack-mounting kit to mount the switch in a recessed position.

Reasons that you might want to mount the switch in a recessed position include:

- You are mounting the switch in a cabinet, and the cabinet doors do not close completely unless the switch is recessed.
- The switch you are mounting has transceivers installed in the uplink ports, and the transceivers in the uplink ports protrude from the front of the switch.

Before you mount an EX4100-F switch in a recessed position inside a 19-in. four-post rack:

- Verify that the site meets the requirements described in EX4100 and EX4100-F Site Guidelines and Requirements.
- Place the rack in its permanent location, allowing adequate clearance for airflow and maintenance, and secure it to the building structure.
- Read *General Safety Guidelines and Warnings*, with particular attention to *Chassis and Component Lifting Guidelines*.

Ensure that you have the following parts and tools available:

- Number 2 Phillips (+) screwdriver (not provided)
- Eight screws to secure the mounting brackets to the rack (not provided)
- An ESD grounding strap (not provided)
- Recessed-mounting brackets to mount the switch in a recessed position from the front posts of a rack—2 (provided with the four-post rack-mounting kit)
- Flat head 4-40 Phillips screws to attach the recessed-mounting brackets to the side rails of the bracket assembly—6 (provided with the four-post rack-mounting kit)
- Flat head 4x6-mm Phillips screws to attach the front-mounting bracket assembly to the chassis—12 (provided with the four-post rack-mounting kit)

To mount an EX4100-F switch in a recessed position from the front posts of a 19-in. four-post rack:

1. Remove the switch from the shipping carton (see "[Unpack the EX4100-F Switch](#)" on page 97).
2. Place the switch on a flat, stable surface.
3. Wrap and fasten one end of the ESD wrist strap around your bare wrist, and connect the other end of the strap to a site ESD point.
4. Attach the recessed-mounting brackets provided with the four-post rack-mounting kit to the side rails by using the flat head 4-40 Phillips screws provided with the four-post rack-mounting kit .

Figure 62: Attach the Recessed-Mounting Bracket to the Side Rail

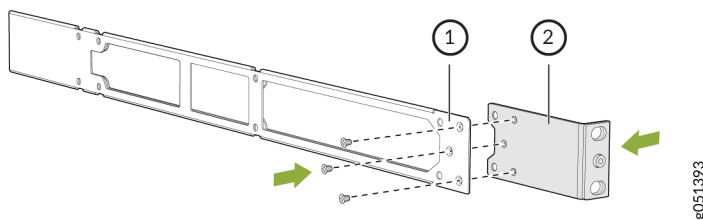

5. Align the recessed-mounting bracket assembly along the side panel of the switch.
6. Insert the flat head 4x6-mm Phillips screws to attach the recessed-mounting bracket assembly into the aligned holes on the chassis provided with the four-post rack-mounting kit and tighten the screws.

Figure 63: Attach the Recessed-Mounting Bracket Assembly to the Switch

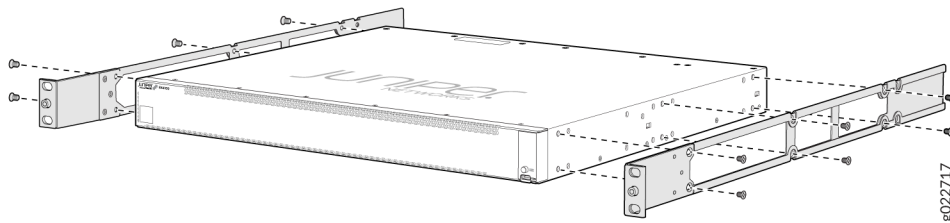

7. Decide which end of the switch you want to place at the front of the rack. Position the switch so that the AIR IN labels on the fan modules are next to the cold aisle and the AIR OUT labels on the fan modules are next to the hot aisle.
8. Have one person grasp both sides of the switch, lift the switch, and position it in the rack, aligning the holes of the mounting brackets with the threaded holes in the front post of the rack. Have the person align the bottom hole in both the mounting brackets with a hole in each rack rail, making sure that the chassis is level.
9. Have a second person secure the mounting brackets to the rack by using four screws appropriate for your rack. Tighten the screws.

Figure 64: Secure the Switch to the Front Posts of a Rack

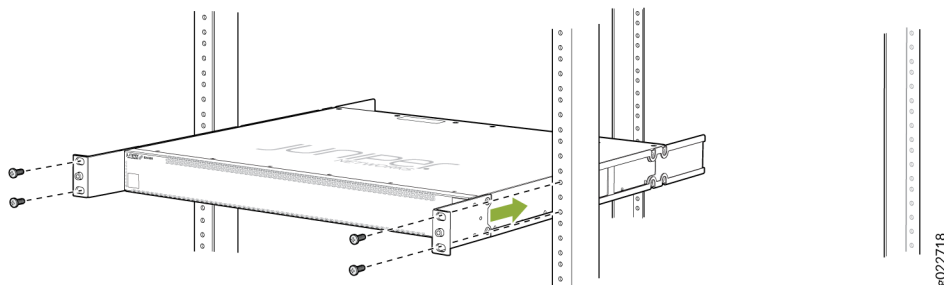

10. Slide the rear-mounting bracket blades into the side rails of the recessed-mounting bracket assembly attached to the switch chassis.
11. Ensure that the chassis is level. Align the holes of the rear-mounting brackets with the threaded holes in the rear post of the rack. Align the bottom hole in both the mounting brackets with a hole in each rack rail. Align the bottom hole in both the rear-mounting brackets with the bottom hole in the front-mounting brackets.
12. Secure the rear-mounting brackets to the rear post of the rack by using four screws appropriate for your rack.

Figure 65: Secure the Switch to the Rear Post of the Rack by Using the Rear-Mounting Brackets

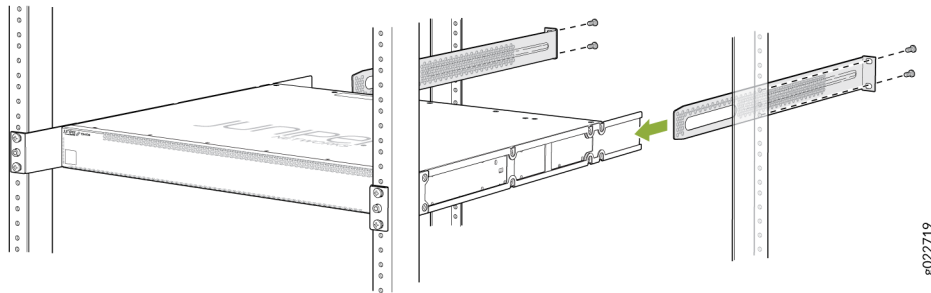

13. Look around the installed switch to ensure that the switch is installed correctly.

Figure 66: Chassis Fully Installed in Rack

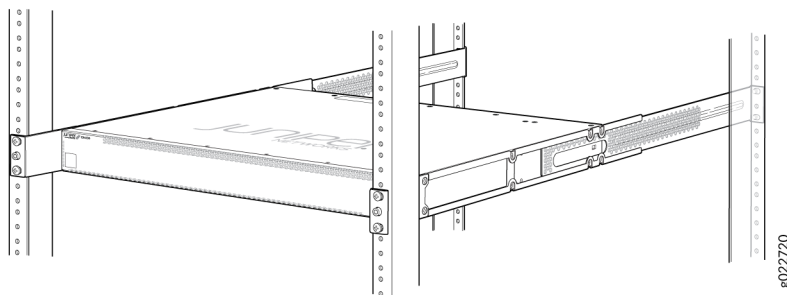

14. If required, cover the SFP ports with the dust covers.

Mount an EX4100-F Switch on a Wall

Before mounting a switch on a wall:

- Verify that the site meets the requirements described in [No Link Title](#).
- Read *General Safety Guidelines and Warnings*, with particular attention to *Chassis and Component Lifting Guidelines*.

Ensure that you have the following parts and tools available:

- 2 wall-mounting brackets (provided in the wall-mounting kit)
- 12 wall-mounting bracket screws (provided in the wall-mounting kit)
- 6 mounting screws (8-32 x 1.25 in. or M4 x 30 mm) (not provided)

- Hollow wall anchors rated to support up to 75 lb (34 kg) if you are not screwing the screws directly into wall studs (not provided)
- Phillips (+) screwdriver, number 2

You can mount an EX4100-F (EX4100-F-24P, EX4100-F-24T, EX4100-F-48P, and EX4100-F-48T) switch on a wall by using the separately orderable wall-mounting kit (EX-WMK).

To mount one or two switches on a wall:

1. Remove the switch from the shipping carton (see ["Unpack the EX4100-F Switch" on page 97](#)).
2. Attach the wall-mounting brackets to the sides of the chassis using four wall-mounting bracket screws on each side, as shown in [Figure 67 on page 110](#).

Figure 67: Attaching Wall-Mounting Brackets to a Switch Chassis

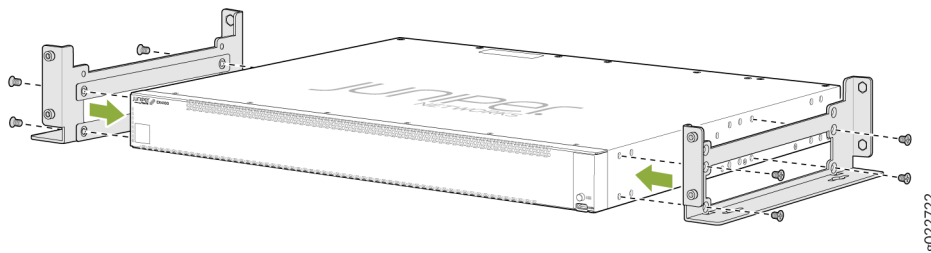

3. Install six mounting screws in the wall for the wall-mounting brackets at the location shown in [Figure 68 on page 111](#):

NOTE: Tighten the screws only partway in, leaving about 1/4 in. (6 mm) distance between the head of the screw and the wall.

- a. Drill a hole (A) and install a mounting screw.
- b. Drill a hole (B) at a distance of 5.98 in. (15.2 cm) from screw A on a level line to the right and install a mounting screw.
- c. Drill a hole (C) at a distance of 18.67 in. (47.43 cm) on a plumb line down from screw A and install a mounting screw.
- d. Drill a hole (D) at a distance of 18.67 in. (47.43 cm) on a plumb line down from screw B and install a mounting screw.

Figure 68: Measurements for Installing Mounting Screws

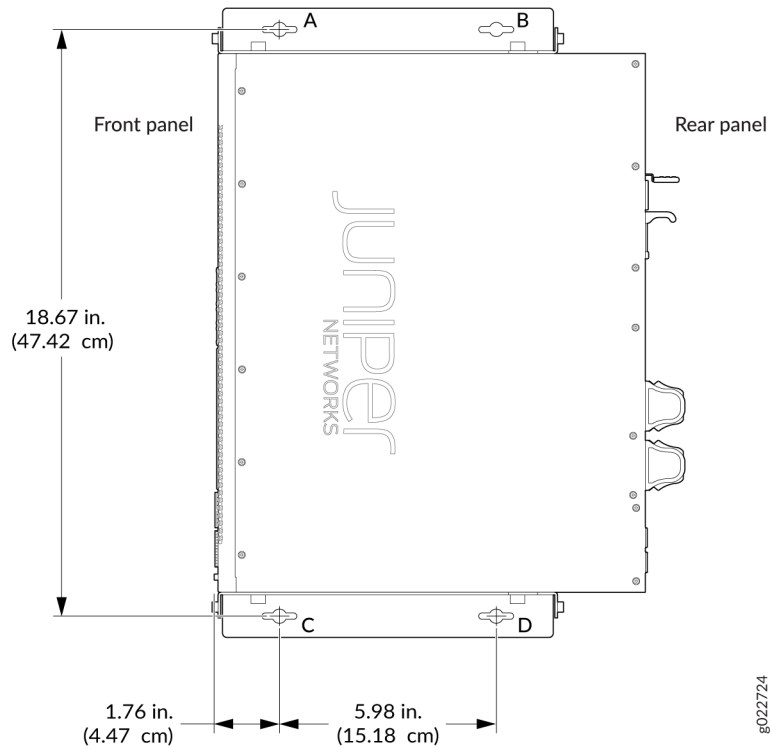

4. Place the switch against the wall such that the front panel of the switch faces to the right side and the holes in the mounting bracket heads align with the mounting screw heads.
5. Slide the switch chassis to the left or right a bit so that the mounting screws are pushed into the channels of the holes in the mounting brackets until the switch rests firmly in place as shown in [Figure 69 on page 112](#).
6. Tighten all mounting screws.

Figure 69: Mounting the Switch on a Wall

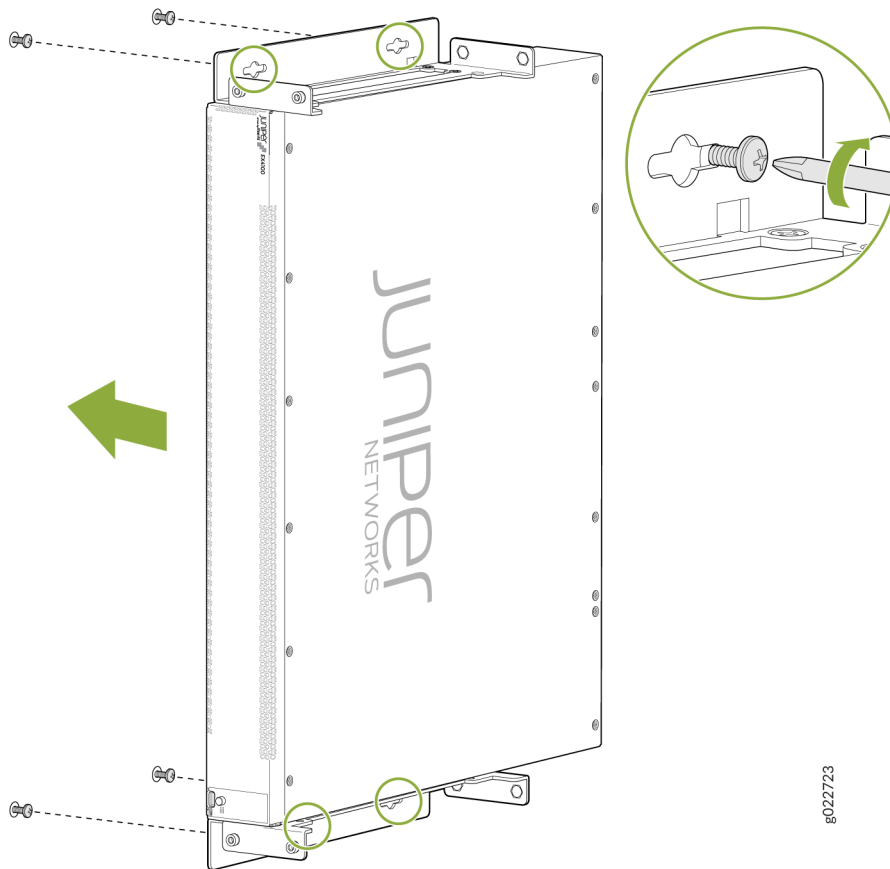

Mounting an EX4100-F-12P and EX4100-F-12T switch

You can mount an EX4100-12P and/or EX4100-12T switch on the desk, on the wall, under a desk or level surface, on a ferrous surface/metallic wall, on two posts of a rack, on two posts of a four post rack, and on a DIN rail.

The default mounting option is on the desk. For the rest of the mounting options, the mounting kits are separately orderable. Also, for all mounting options, you can optionally use the following. These are separately orderable parts:

- 1 cable guard kit. The kit includes the cable guard and 3 M3 screws to secure the cable guard to the switch. See ["Attaching the Cable Guard to Protect Cable Connections" on page 137](#).

- 1 standard cable lock to secure the switch from theft by connecting the cable to the security slot on the switch and a desk or a rack to fasten the cable lock. It includes the standard cable lock and its key. See "[Attaching the Standard Cable Lock to the Security Slot of the Switch](#)" on page 139.

NOTE: The under-the-desk mounting kit and wall-mounting kit are common.

For every mounting option, follow these guidelines:

- Verify that the site meets the requirements described in No Link Title.
- Place the site of installation such as the desk, ferrous surface, or rack in its permanent location, allowing adequate clearance for airflow and maintenance, and secure it to the building structure.
- Read [General Safety Guidelines and Warnings](#) with particular attention to Chassis and Component Lifting Guidelines.
- Remove the switch from the shipping carton (see "[Unpack the EX4100-F Switch](#)" on page 97).

Mounting an EX4100-F-12P and EX4100-F-12T Switch on a Desk

You can mount the EX4100-F-12P and/or EX4100-F-12T switch and its power adapter on a desk or other level surface. The surface should be flat or level and shall not be an inclined surface or area.

NOTE: Allow sufficient space of 6 inches all around the switch for cooling. Insufficient space can lead to overheating of the switch chassis.

To mount a switch on a desk or other level surface:

1. Place the switch and its adapter on the desk or the level surface. The following image shows an EX4100-F-12P switch mounted on a desk. The same procedure applies to an EX4100-F-12T switch as well.

Figure 70: EX4100-F-12P Switch Mounted on a Desk

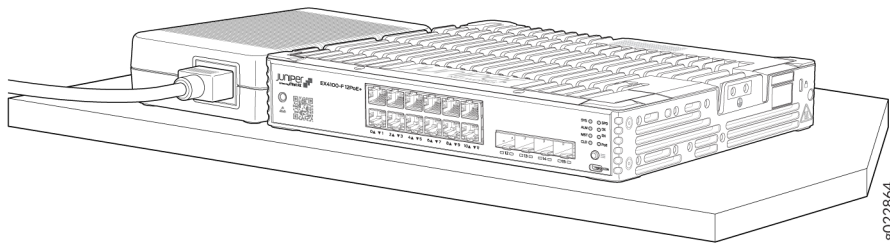

2. Ensure that the switch rests firmly on the desk or level surface.

Mounting an EX4100-F-12P and EX4100-F-12T Switch Under a Desk or Other Level Surface

Ensure that you have the following parts and tools available:

- Under the desk mounting brackets
- Power Adaptor Tray
- Six M4 screws to attach the mounting brackets to the chassis.
- Phillips (+) screwdriver, number 2 (not provided in the mounting kit)
- Seven M4 x L15mm screws for mounting the switch and power adaptor tray.
 - Screws for mounting switch - 4 pcs
 - Screws for mounting the power adaptor tray - 3 pcs

You can mount an EX4100-F-12P and/or EX4100-F-12T switch along with its power adaptor under a desk or other level surface. You do this by attaching the mounting brackets to the chassis and securing it to the surface under the desk. For the power adaptor, you use screws to secure the power adaptor tray to the surface under the desk.

NOTE: Allow clearance of 6 inches all around the switch for thermal cooling.

NOTE: The desk or level surface should be suitable to hold screws firmly.

NOTE: Do not block the vents on the top of the switches. Blocking the vents can lead to overheating of the switch chassis.

To mount the switch under a desk or other level surface by using screws:

1. Assemble the mounting brackets to the chassis using the six M4 screws; three each side.

Figure 71: Assembling the mounting brackets to the chassis using six M4 screws; three for each side.

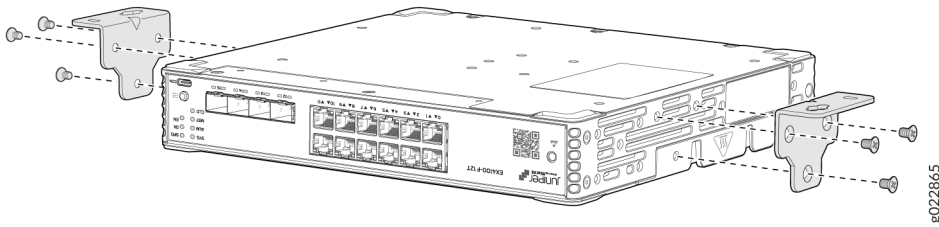

2. Secure the switch under the desk using four (of seven) M4xL15mm screws.

Figure 72: Measurements for installing mounting screws for mounting the switch and power adaptor tray under a desk

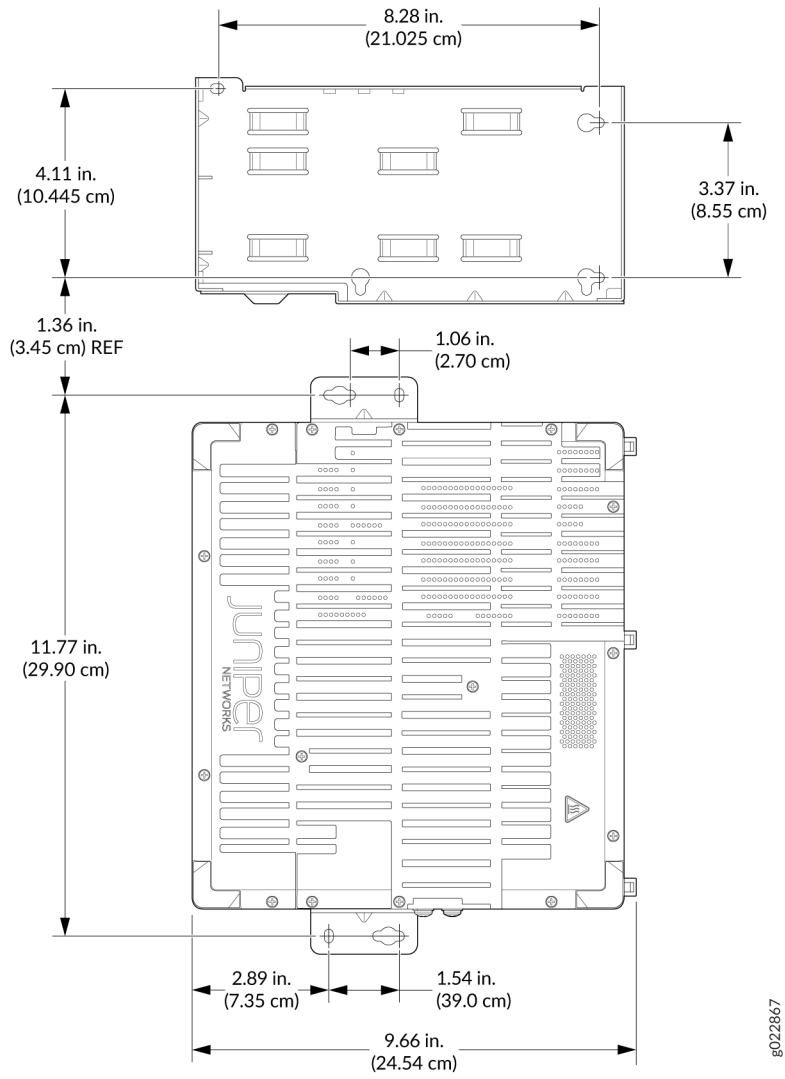
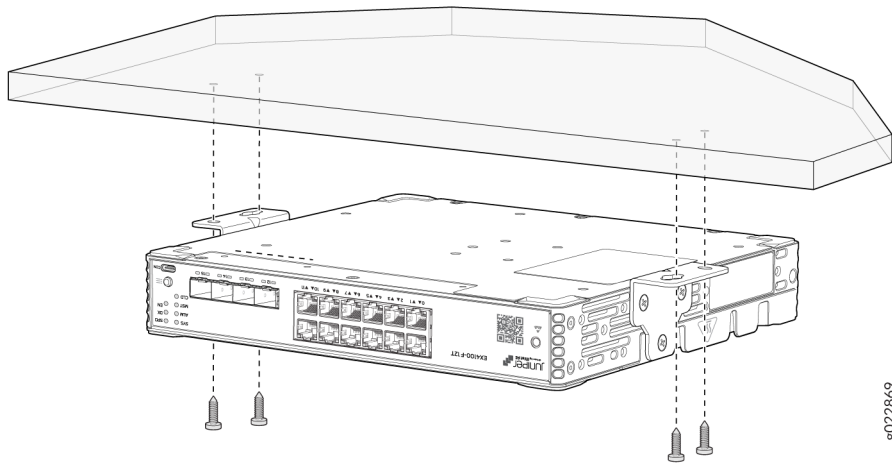

Figure 73: Switch secured under the desk using four M4xL15mm screws



3. Attach the power adaptor to the power adaptor tray. See ["Attaching the Power Adaptor to the Power Adaptor Tray"](#) on page 135.
4. Secure the power adaptor under the desk using three M4xL15mm screws.

Figure 74: Power adaptor tray secured under the desk using three M4xL15mm screws

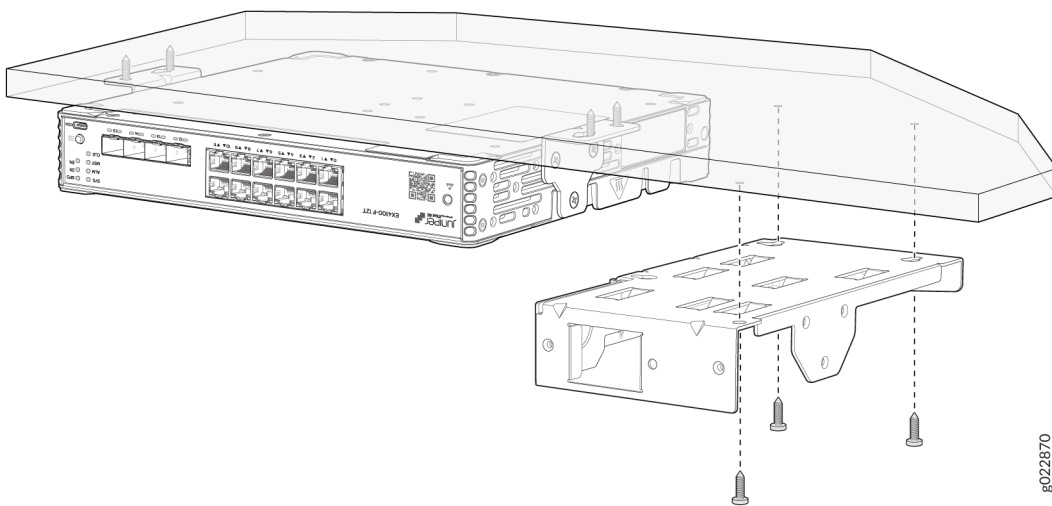
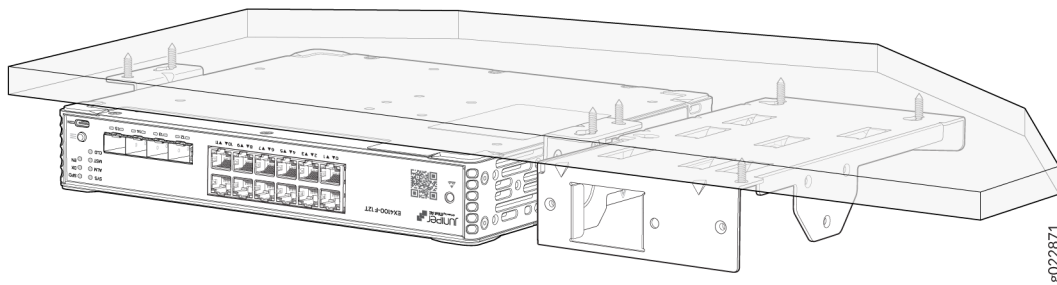

Figure 75: Switch and power adaptor tray mounted under the desk



Mounting an EX4100-F-12P and EX4100-F-12T Switch on Two Posts of a Rack

Ensure that you have the following parts and tools available:

- Two 2-post rack mounting ears
- Eight M4 screws to assemble mounting ear on the left and right side.
- Three M4 screws to attach power adaptor tray to the switch chassis.
- Phillips (+) screwdriver, number 2 (not provided in the 2-post rack mounting kit).
- Screws to mount switch to the rack (not provided).
- Power adaptor tray (provided with the 2-post rack mounting kit but not provided with the 2-post rack mounting ear kit).

You can mount EX4100-F-12P and/or EX4100-F-12T switches on two-posts of a two-post rack or two-posts of a four-post 19-in. rack by using the mounting ears and screws provided in the separately orderable 2-post rack mounting kit. The remainder of this topic uses rack to mean rack or cabinet.

There are three types of 2-post rack mounting kits.

- RMK (rack mounting kit) - the one with power adaptor tray
- RME (rack mounting ears) - the one with rack-mounting ears or front-mounting brackets only, but with no power adaptor tray.
- PAT (power adaptor tray) - Power adaptor tray can be ordered separately and to be mounted along with RME kit.

NOTE: Allow 3RU space on top of the switch and 6 inch space all around the switch.

To mount the switch on two posts of a two-post rack or two posts of a four-post rack:

1. Attach the power adaptor tray to the switch chassis. See "[Attaching the Power Adaptor Tray to the Switch Chassis](#)" on page 137. This step is not applicable if installing the switch using the 2-post rack mounting ear kit.
2. Attach the power adaptor to the power adaptor tray. See "[Attaching the Power Adaptor to the Power Adaptor Tray](#)" on page 135. This step is not applicable if installing the switch using the 2-post rack mounting ear kit.
3. Secure the two-post mounting ears using four M4 screws on either side of the chassis as shown in the following figures.

Figure 76: Secure the two-post mounting ears

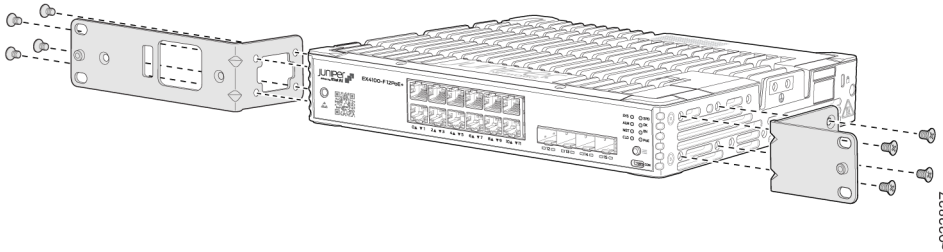

The following is the figure of only the rack-mounting ears attached to the switch chassis, if RME kit is used.

Figure 77: Rack-mounting Ears Attached to the Switch Chassis



The following is the figure of the power adaptor tray attached to the switch chassis. The rack mount ears are attached to the switch chassis and then power adaptor tray is attached.

Figure 78: Attaching Power Adaptor Tray (PAT)

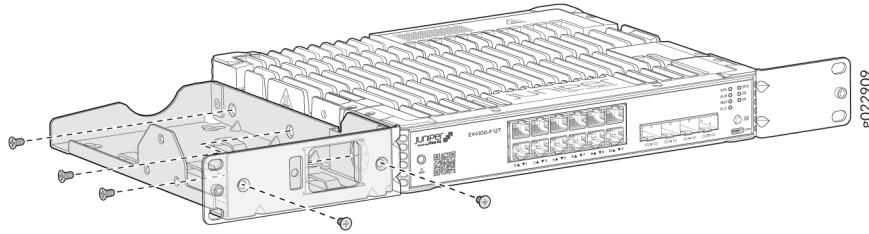

The following is the figure of power adaptor tray attached to the switch chassis, if RMK is used.

Figure 79: Power Adaptor Tray Attached to the Switch Chassis

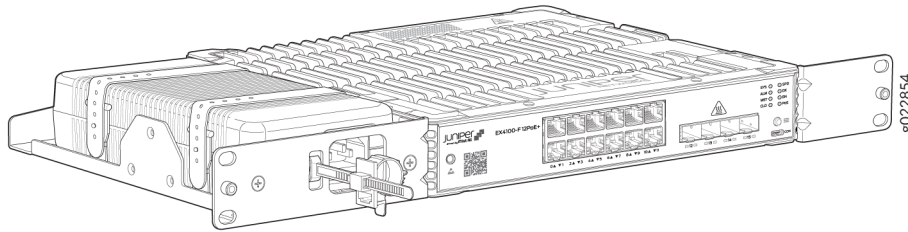

4. Have one person grasp the sides of the device, lift it, and position it in the rack.
5. Align the bottom hole in each mounting bracket with a hole in each rack rail as shown in the figure, ensuring that the chassis is level.

Figure 80: Mounting the Switch with the Power Adaptor to the Two-post Rack

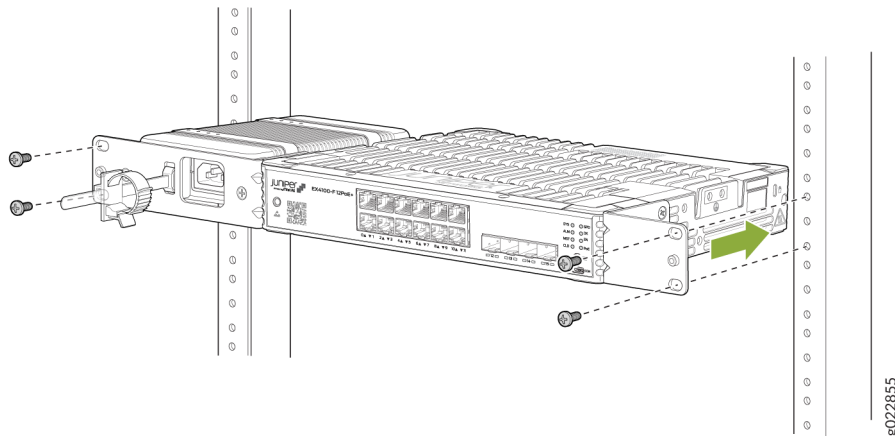

- The following figure depicts the switch mounted on two posts of a two-post rack or two posts of a four-post rack with the power adaptor tray attached when using the RMK or PAT kit along with RME kit.

Figure 81: Mounting the switch without the power adaptor tray to the two-post rack

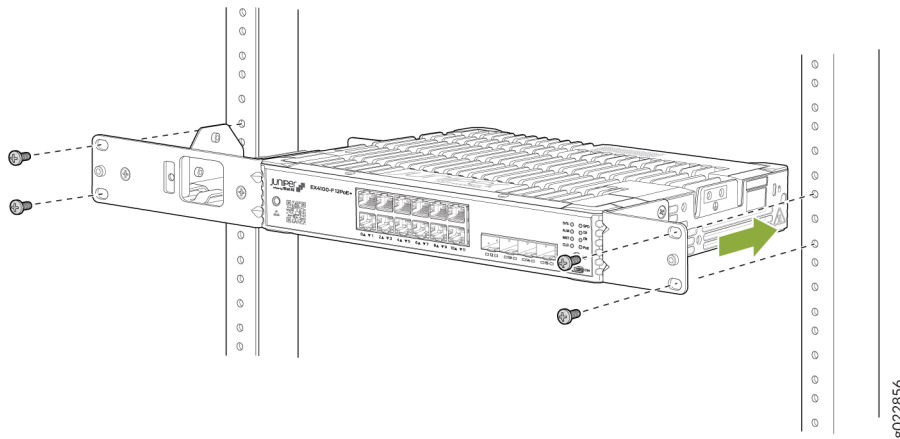

- Have a second person install a mounting screw into each of the two aligned holes. Tighten the mounting screws.
- Install the second screw in each mounting ear.
- Verify that the mounting screws on one side of the rack are aligned with the mounting screws on the opposite side and that the device is level.

Mounting an EX4100-F-12P and EX4100-F-12T Switch on a Wall

Before mounting the switch on a wall, verify that you have the following parts available in your wall-mounting kit:

NOTE: Allow sufficient space of 6 inches all around the switch for cooling. Insufficient space can lead to overheating of the switch chassis.

NOTE: You can mount the EX4100-F-12P and/or EX4100-F-12T switches on a wall, at a height of no more than 2 meters.

- Two wall-mounting brackets
- Screws to attach the wall-mounting brackets – six M4 screws (3 pcs each side)
- Power adaptor tray; three M4 screws to attach power adaptor tray to switch
- Phillips (+) screwdriver, number 2 (not provided in the wall mounting kit)
- Four plastic wall anchors
- Four M4xL20mm screws to mount switch and power adaptor tray on the wall

To install the device on a wall:

1. Attach the power adaptor tray to the switch chassis. See ["Attaching the Power Adaptor Tray to the Switch Chassis" on page 137.](#)
2. Attach the power adaptor to the power adaptor tray. See ["Attaching the Power Adaptor to the Power Adaptor Tray" on page 135.](#)
3. Attach the wall-mounting brackets using the six M4 screws.

Figure 82: Attaching the wall mounting brackets

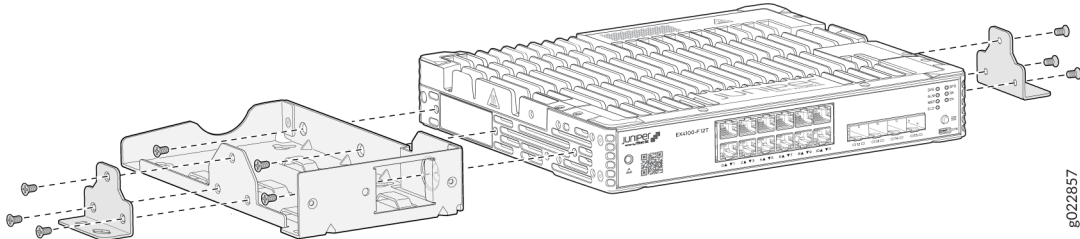

4. Drill 6mm holes on the wall at 4 places as shown in the following figure. These are the wall measurements for installing mounting screws to mount the switch with the power adaptor tray on a wall.

Figure 83: Wall Measurements for Installing Mounting Screws

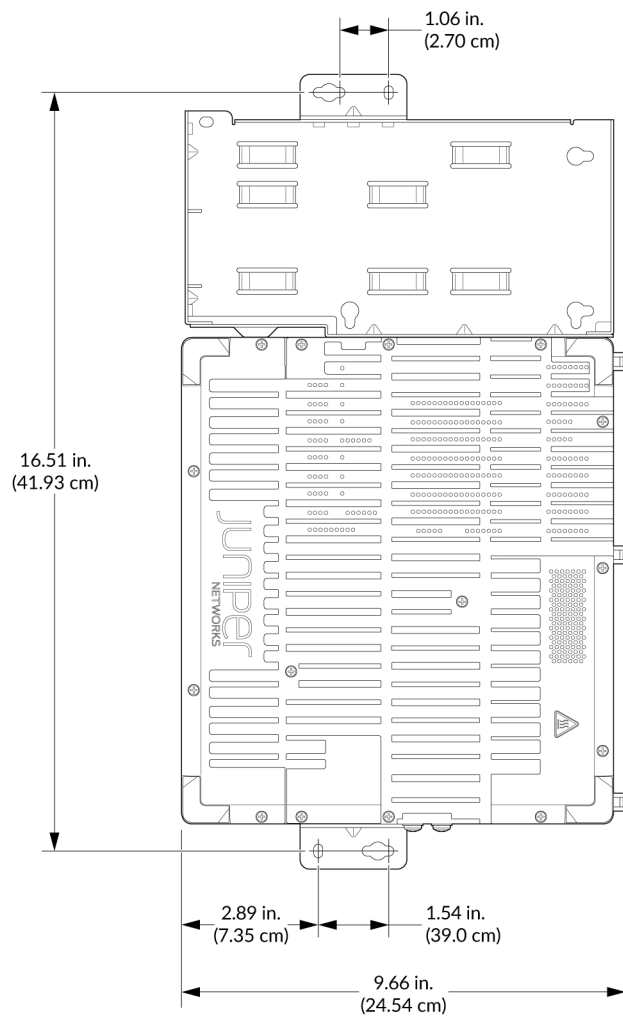

5. Insert the four plastic wall anchors into the holes.

Figure 84: Attach Plastic Anchors to the Wall

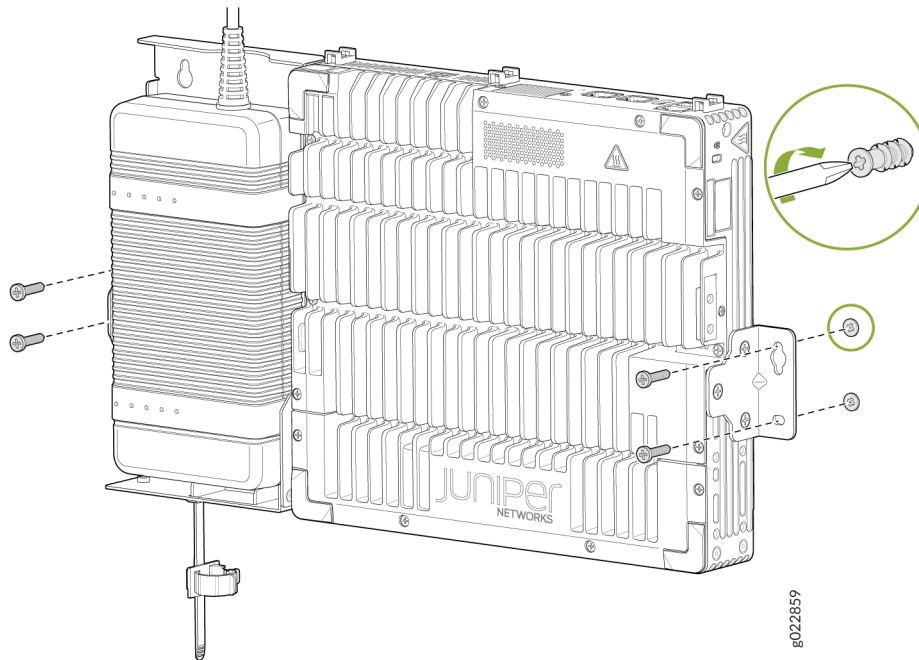

6. Have one person grasp the sides of the device, lift it, and position it on the wall.
7. Have a second person install two pairs of M4xL20mm mounting screws through the bracket holes on either side of the switch and power adaptor tray to secure it to the wall.
8. Verify that the mounting screws on one side are aligned with the mounting screws on the opposite side and that the device is at the same level.

Figure 85: Switch and Power Supply Adaptor Mounted to the Wall with the Correct Orientation

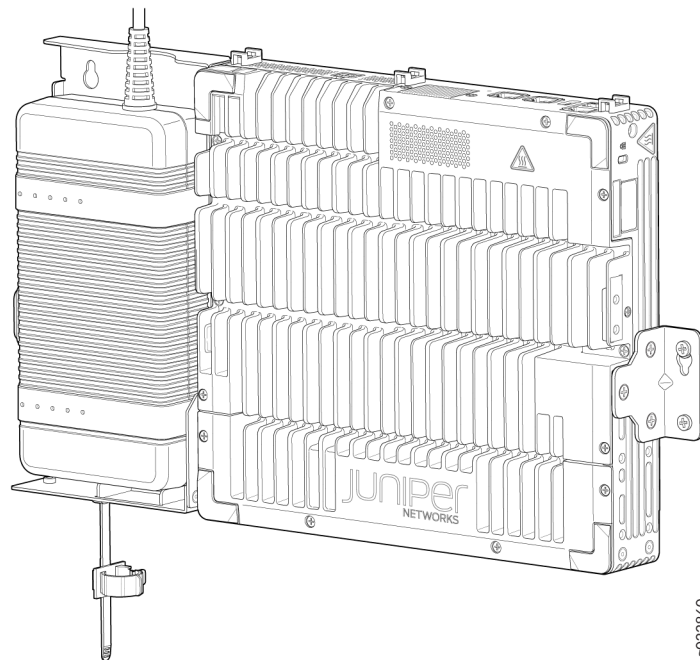

Mounting an EX4100-F-12P and EX4100-F-12T Switch on a Ferrous Wall using Magnet Pads

Ensure that you have the following parts and tools available:

- Magnet tray
- Six M3 screws
- Two magnet pads

NOTE:

- You can mount the EX4100-F-12P and/or EX4100-F-12T switches on a ferrous wall using magnet pads, at a height of no more than 2 meters.
- The ferrous wall shall be smooth and free of any contaminants like oil, grease, dirt, etc., as otherwise the unit may fall.

- The ferrous wall on which the switch is mounted shall not be close to any area where vibration or impact may occur. Also, mounting the product near any heat generating area can cause the mounting to malfunction.
- Allow sufficient space of 6 inches all around the switch for cooling. Insufficient space can lead to overheating of the switch chassis.
- The ferrous wall on which the switch will be mounted shall be flat and the surface shall be without any undulation. The ferrous wall shall be well supported and strong enough to support the switch.

To mount the switch on a surface made of ferrous material:

1. Attach the power adaptor to the power adaptor tray. See "[Attaching the Power Adaptor to the Power Adaptor Tray](#)" on page 135.
2. Turn the chassis upside down.
3. Use the Phillips (+) screwdriver (number 2) to assemble the magnet tray on the bottom side of the switch by using six M3 screws. In the following figure, the magnet tray and magnet tray being assembled on the bottom side of the switch using the screws is shown.

Figure 86: Magnet Tray Assembled on the Bottom Side of the Switch

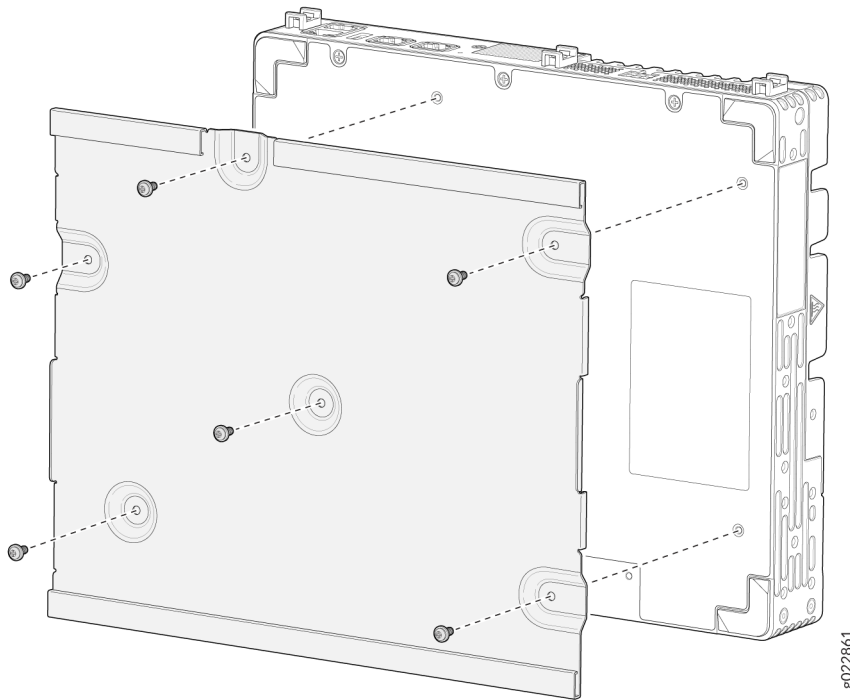

4. Attach the switch and power supply adaptor to the ferrous surface using the appropriate magnet pad.

Figure 87: Attach the Switch and Power Supply Adaptor to the Ferrous Surface

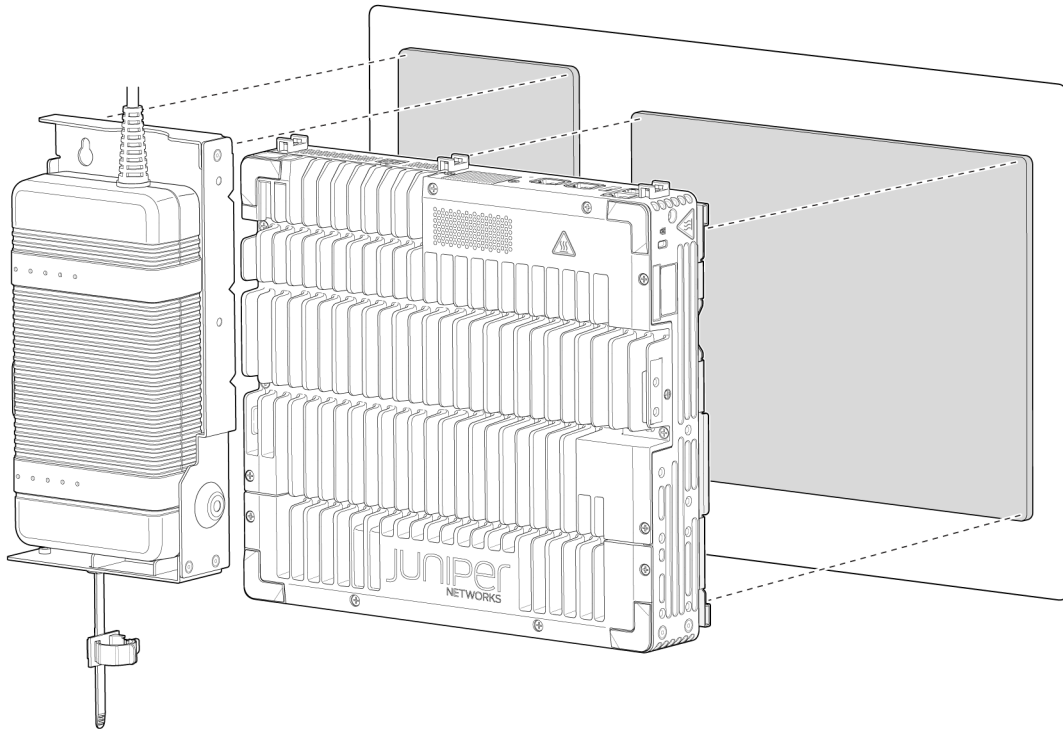

8022862

Figure 88: Switch and Power Supply Adaptor Mounted to the Ferrous Surface

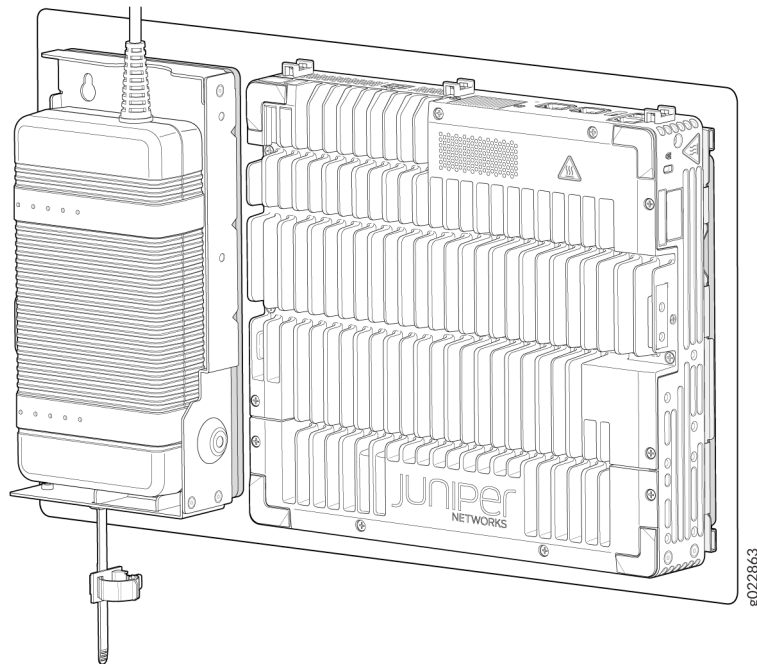

Mounting an EX4100-12P and EX4100-12T Switch on a DIN Rail

Ensure that you have the following parts and tools available:

- DIN mounting bracket
- Four M4 Pan Head screws

NOTE:

- The product can be mounted onto a standard 35mm DIN rail
- Allow sufficient space of 6 inches all around the switch for cooling. Insufficient space can lead to overheating of the switch chassis.

1. Attach the power adaptor tray to the switch chassis. See "[Attaching the Power Adaptor Tray to the Switch Chassis](#)" on page 137.
2. Attach the power adaptor the power adaptor tray. See "[Attaching the Power Adaptor to the Power Adaptor Tray](#)" on page 135.

3. Use the Phillips (+) screwdriver, number 2, to assemble the DIN mounting bracket using four M4 Pan Head screws onto the bottom of the switch chassis.

Figure 89: Assembling the DIN Mounting Bracket

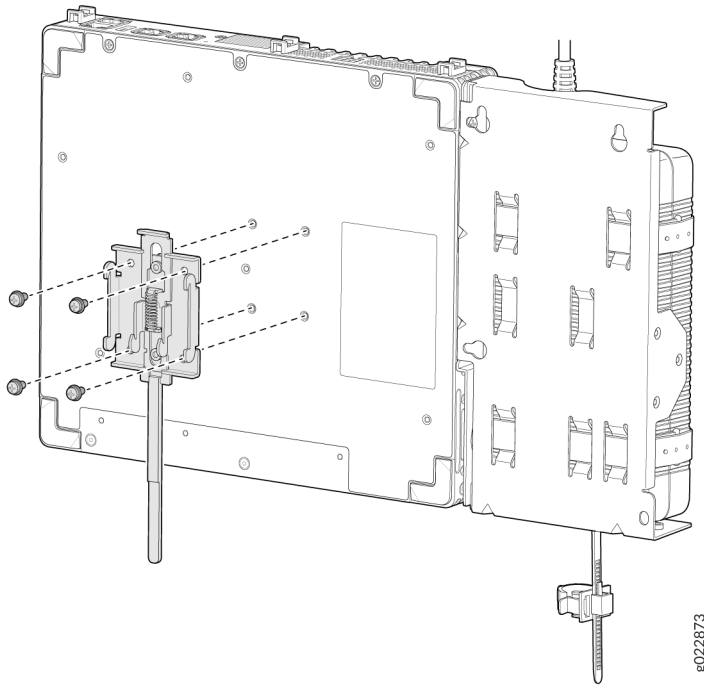

4. Position the switch in front of the DIN rail.
5. Clip the DIN mounting bracket onto the standard 35mm DIN rail.

Figure 90: Clipping the DIN Mounting Bracket onto the DIN Rail

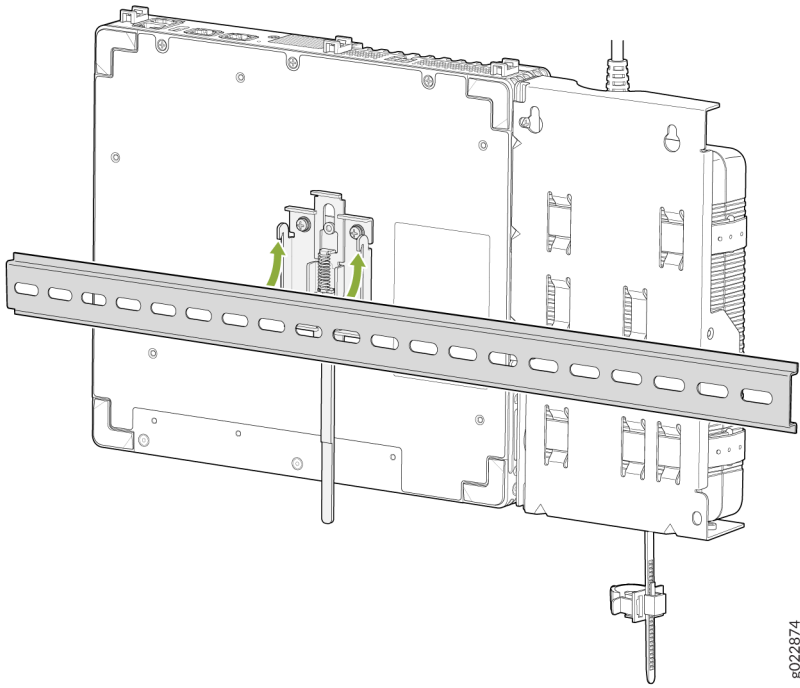

8022874

Figure 91: Rear View and Front View of the Switch and Power Supply Adaptor Mounted on the DIN Rail

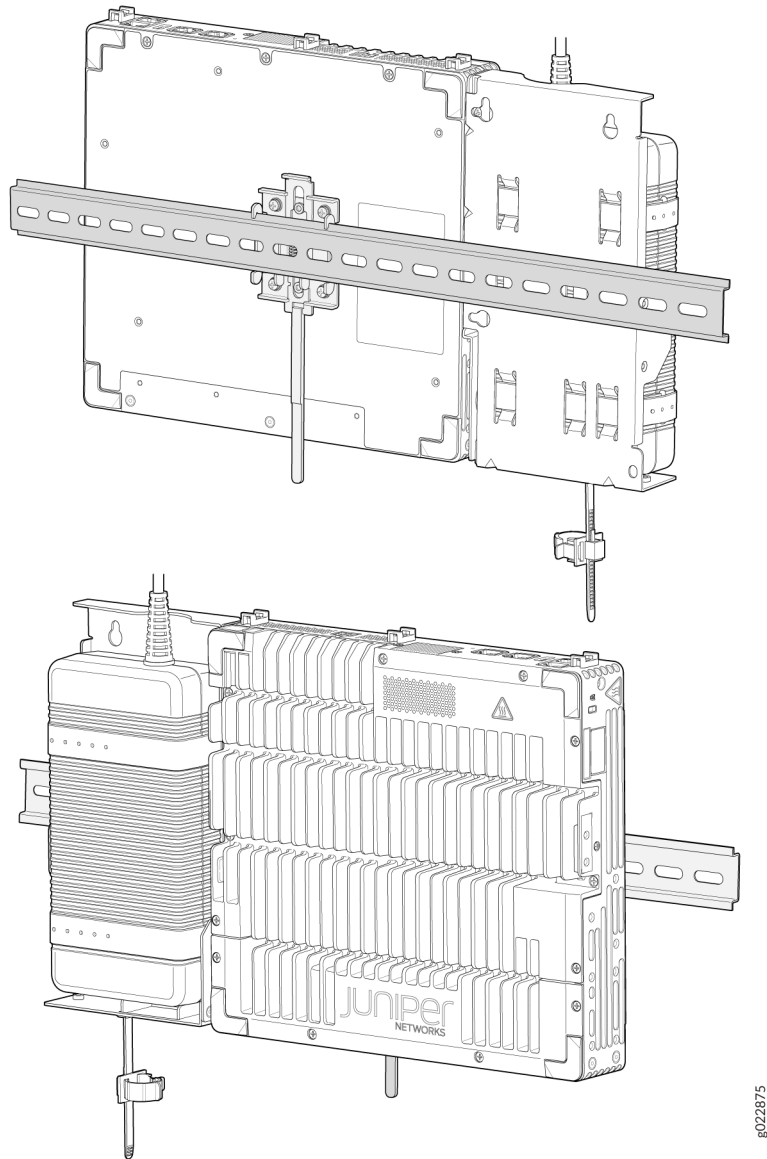

8022875

Unmounting an EX4100-F-12P and EX4100-F-12T Switch From a DIN Rail

To unmount the switch from a DIN rail:

1. Ensure power is removed from the switch and all cables and connectors are removed from the switch.
2. Slowly pull the lever down to disengage the DIN mounting bracket. While the switch is disengaged, pull the bottom of the switch away from the DIN rail and lift the hooks off the DIN rail.

Figure 92: Velcro Pulled Downwards to Disengage the DIN Mounting Bracket

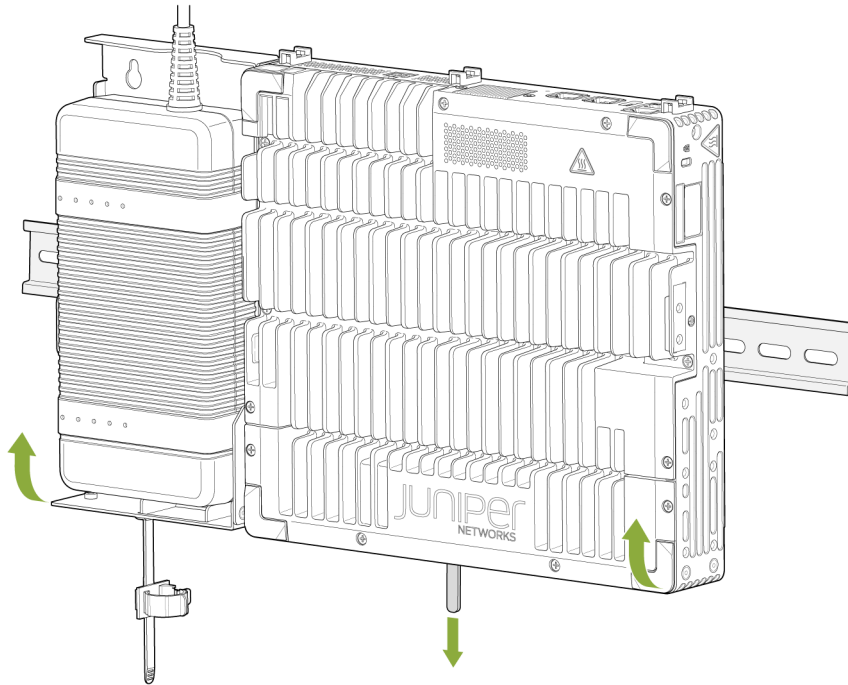

g022876

Figure 93: Velcro Pulled Downwards to Disengage the DIN Mounting Bracket

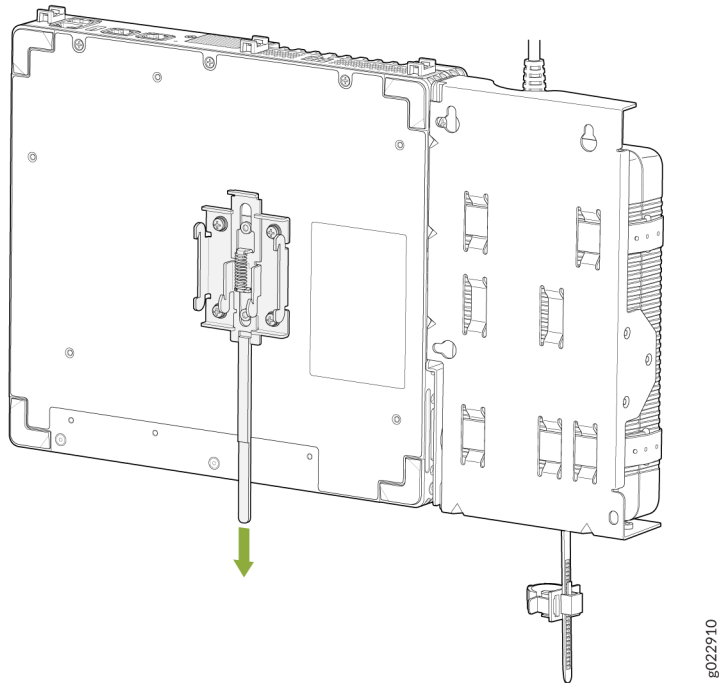

3. Remove the switch from the DIN rail mount.

Common Instructions for EX4100-F-12P and EX4100-F-12T Mounting Options

The following instructions are common across the mounting options for EX4100-F-12P and EX4100-F-12T.

- ["Attaching the Power Adaptor to the Power Adaptor Tray" on page 135](#)
- ["Attaching the Power Adaptor Tray to the Switch Chassis" on page 137](#)
- ["Attaching the Cable Guard to Protect Cable Connections" on page 137](#)
- ["Attaching the Standard Cable Lock to the Security Slot of the Switch" on page 139](#)

Attaching the Power Adaptor to the Power Adaptor Tray

Attaching the power adaptor to the power adaptor tray is a pre-step for 2-post racking, under the desk, wall, magnet, and DIN rail mounting of the EX4100-F-12P and EX4100-F-12T switch.

To attach the power adaptor to the power adaptor tray:

1. Attach the cable belt to the power adaptor tray.

Figure 94: Cable Belt Attachment to the Power Adaptor Tray - EX4100-F-12P

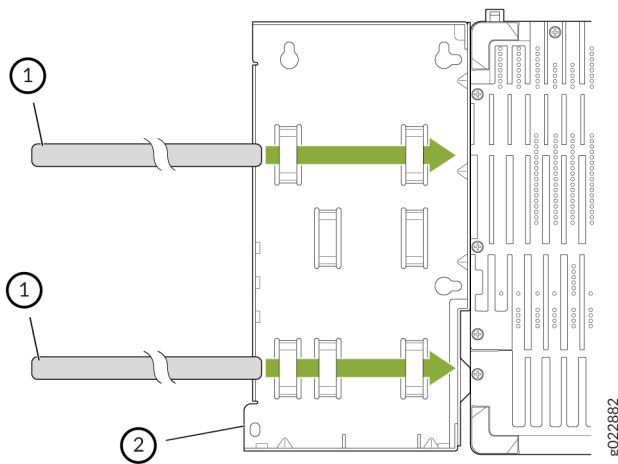
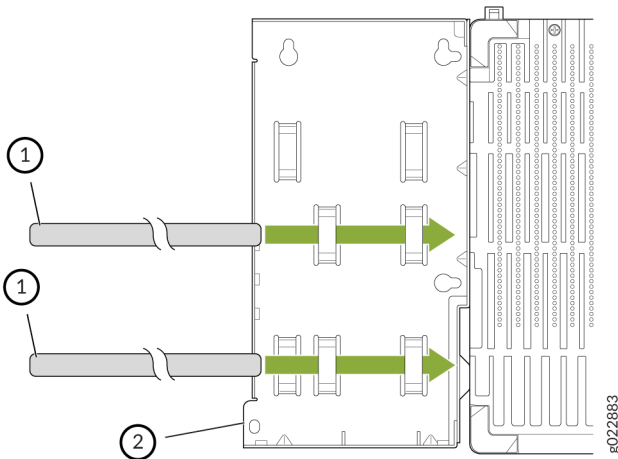

Figure 95: Cable Belt Attachment to the Power Adaptor Tray - EX4100-F-12T



2. Place the power adaptor on the power adaptor tray.

Figure 96: Placing the Power Adaptor on the Power Adaptor Tray - EX4100-F-12P

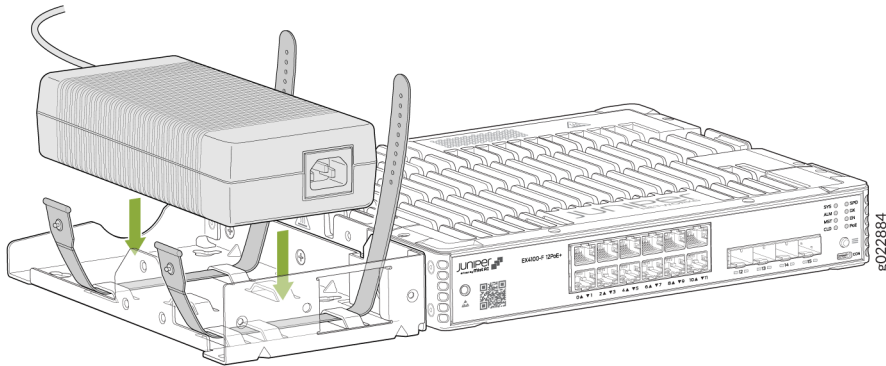
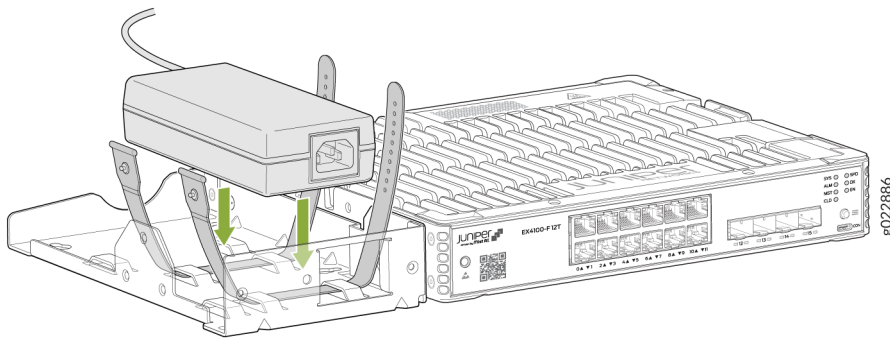

Figure 97: Placing the Power Adaptor on the Power Adaptor Tray - EX4100-F-12T



- 3. Lock the power adaptor onto the power adaptor tray using the cable belt at two places.

Figure 98: Locking the Power Adaptor Using the Cable Belt - EX4100-F-12P

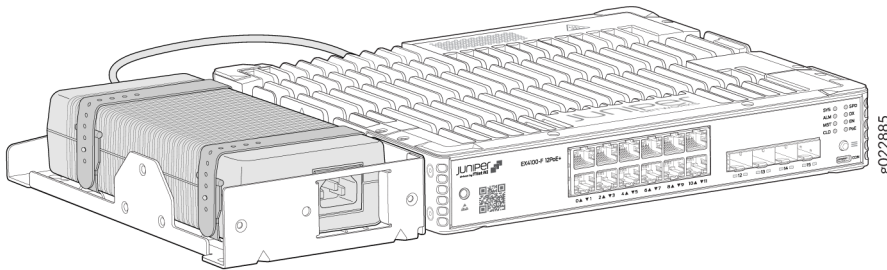
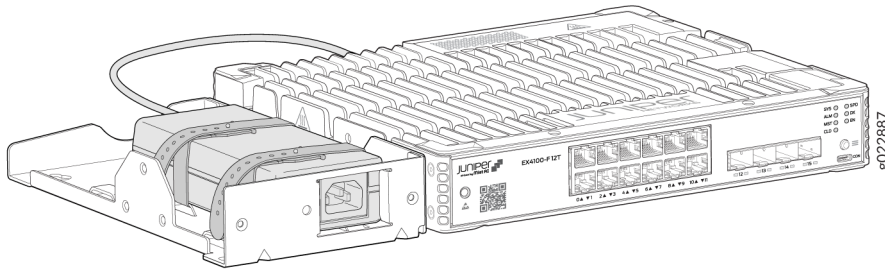

Figure 99: Locking the Power Adaptor Using the Cable Belt - EX4100-F-12T



Attaching the Power Adaptor Tray to the Switch Chassis

Attaching the power adaptor tray to the switch chassis is a pre-step for 2-post rack mounting and DIN rail mounting of the EX4100-F-12P and EX4100-F-12T switch. However, for 2-post rack mounting, secure the power adaptor tray to the switch chassis, only after securing the front-mounting brackets.

1. Secure the power adaptor to the power adaptor tray. See ["Attaching the Power Adaptor to the Power Adaptor Tray"](#) on page 135.
2. Secure the power adaptor tray to the left side of the switch chassis using three M4 screws.

Figure 100: Attaching the power adaptor tray to the switch chassis

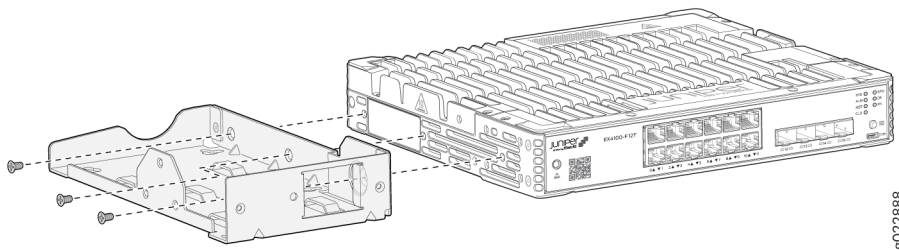

Attaching the Cable Guard to Protect Cable Connections

You can optionally attach cable guard to the chassis to protect cable connections.

Use the three M3 screws and Phillips (+) screwdriver, number 1, to attach the cable guard to the bottom of the chassis.

Figure 101: Attaching a cable guard to the switch

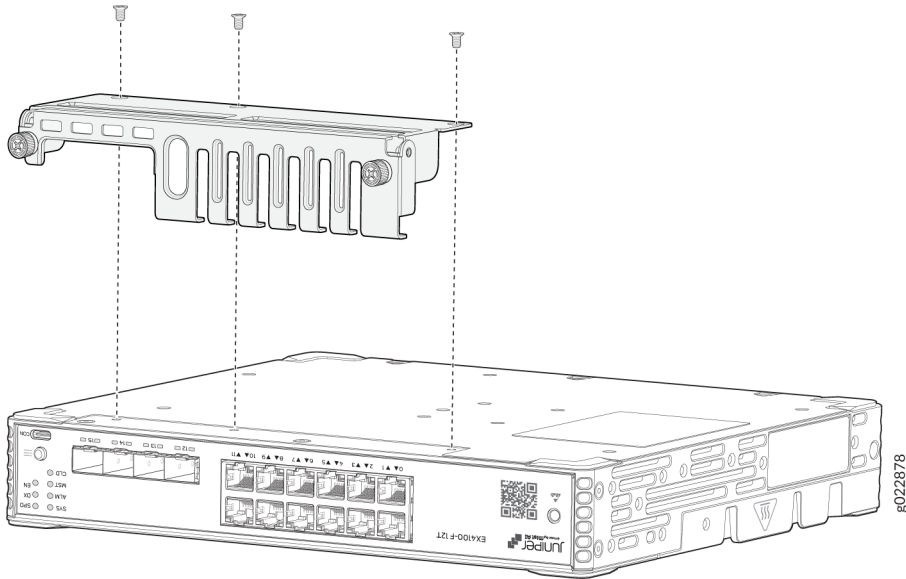

Figure 102: Cable Guard Door- Closed Position

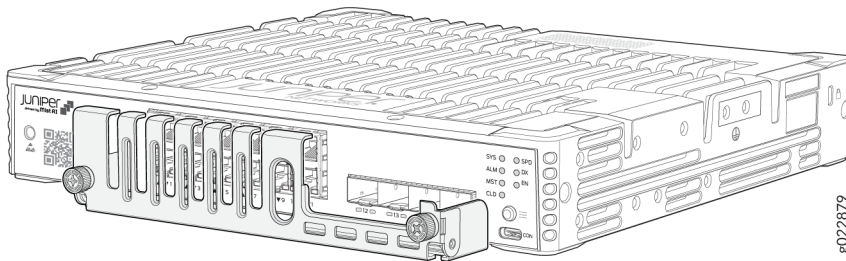
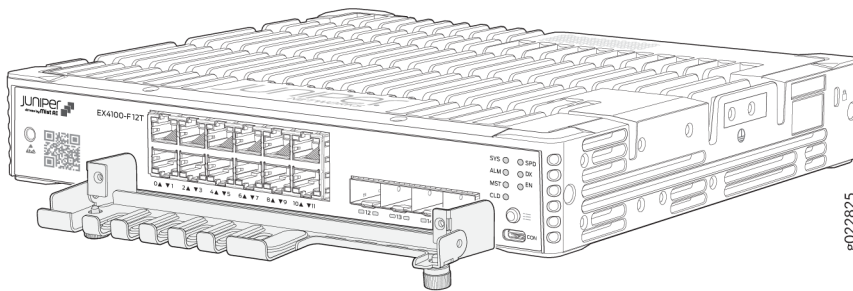

Figure 103: Cable Guard Door- Open Position



Attaching the Standard Cable Lock to the Security Slot of the Switch

You can optionally secure the switch using the security slot.

1. Fasten the cable to a desk or a rack and set the lock to unlocked position using the key.
2. Insert the lock into the security slot on the switch.

Figure 104: Inserting Lock into the Security Slot on the Switch

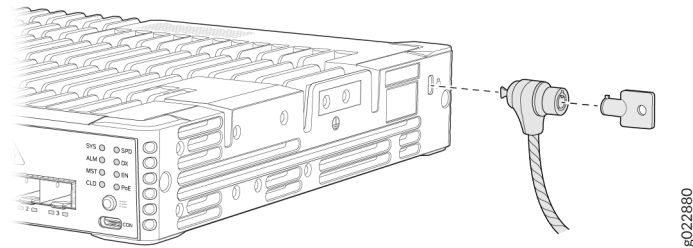

g022880

3. Set the lock to the locked position using the key.

Figure 105: Setting the Lock to the Locked Position Using the Key

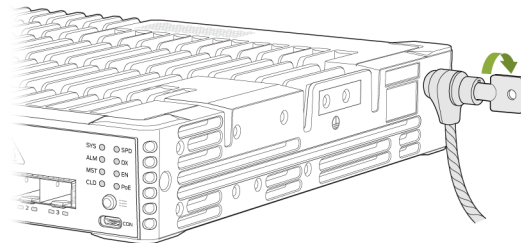

g022881

Connect the EX4100-F to Power

IN THIS SECTION

- [Connect Earth Ground to an EX4100-F Switch | 140](#)

- [Connect AC Power to an EX4100-F Switch | 142](#)
- [Connect AC power to an EX4100-F-12P and EX4100-F-12T Switch | 145](#)

Connect Earth Ground to an EX4100-F Switch

To ensure proper operation and to meet safety and electromagnetic interference (EMI) requirements, you must connect EX4100-F switches to earth ground before you connect power to the switch. You must use the protective earthing terminal on the switch chassis to connect the switch to earth ground (see [Figure 106 on page 142](#) and [Figure 107 on page 142](#)).

You must install the EX4100-F switches in a restricted-access location and ensure that the chassis is always properly grounded. EX4100-F switches have a two-hole protective grounding terminal on the rear panel of the chassis. Under all circumstances, use this grounding connection to ground the chassis. For AC-powered systems, you must also use the grounding wire in the AC power cord along with the two-hole grounding lug connection. This tested system meets or exceeds all applicable EMC regulatory requirements with the two-hole protective grounding terminal.



CAUTION: Ensure that a licensed electrician has attached the appropriate grounding lug to the grounding cable that you supply. Using a grounding cable with an incorrectly attached lug can damage the switch.

Before you connect earth ground to a EX4100-F switch, ensure that you have parts and tools listed in [Table 45 on page 140](#) available:

Table 45: Parts Required for Connecting an EX4100-F Switch to Earth Ground

Item	Switch Models	Description
Earthing terminal location	All EX4100-F switches	Rear panel of the chassis
Grounding cable requirements	All EX4100-F switches	8 AWG (3.26 mm ²), minimum 90° C wire, or as permitted by the local code—not provided

Table 45: Parts Required for Connecting an EX4100-F Switch to Earth Ground *(Continued)*

Item	Switch Models	Description
Grounding lug specifications	EX4100-F-24P, EX4100-F-24T, EX4100-F-48P, and EX4100-F-48T switches	Panduit LCD8-14A-L or equivalent—not provided
	EX4100-F-12P and EX4100-F-12T switches	Panduit LCD8-10A-L—not provided
Screws to secure the grounding lug	EX4100-F-24P, EX4100-F-24 T, EX4100-F-48P, and EX4100-F-48T switches	Two M5X10mm screws with washer—seperately orderable
	EX4100-F-12P and EX4100-F-12T switches	10-32 screws—not provided
Tools required	All EX4100-F switches	Number 2 Phillips (+) screwdriver— not provided Electrostatic discharge (ESD) grounding strap—not provided

To ground the EX4100-F switch to a proper ground reference:

1. Connect one end of the grounding cable to a proper earth ground, such as the rack in which the switch is mounted.
2. Place the grounding lug attached to the grounding cable over the protective earthing terminal on the rear panel (see [Figure 106 on page 142](#) and [Figure 107 on page 142](#)).

Figure 106: Connect a Grounding Cable to an EX4100-F-24P, EX4100-F-24T, EX4100-F-48P, and EX4100-F-48T Switch

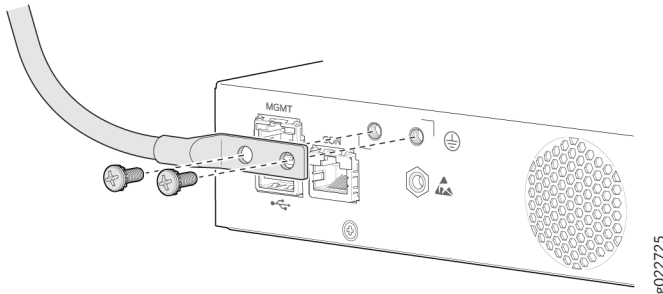
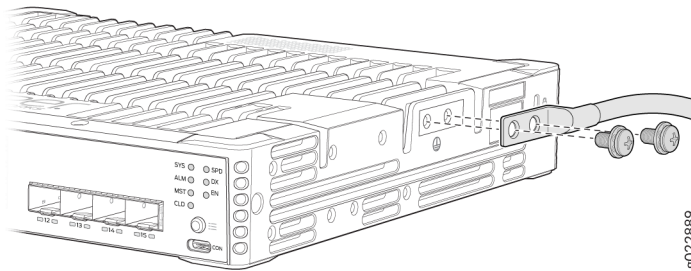

Figure 107: Connect a Grounding Cable to an EX4100-F-12P and EX4100-F-12T Switch



3. Secure the grounding lug to the protective earthing terminal with the screws.
4. Secure the grounding cable and ensure that it does not touch or block access to other switch components.



WARNING: Ensure that the cable does not drape where people could trip over it.

Connect AC Power to an EX4100-F Switch

These instructions apply to EX4100-F-24P, EX4100-F-24T, EX4100-F-48P, EX4100-F-48T, EX4100-24MP, and EX4100-48MP switches. Before you connect AC power, ensure that you have the following parts and tools available:

- A power cord appropriate for your geographical location

- A power cord retainer clip (provided with the switch)

Ensure that you have connected the device chassis to earth ground. The AC power cords also provide additional grounding when you connect the power supply in the switch to a grounded AC power outlet by using the AC power cord appropriate for your geographical location (see No Link Title).



CAUTION: For installations that require a separate grounding conductor to the chassis, have a licensed electrician complete this connection before you connect the switch to power. For instructions on connecting earth ground, see "[Connect Earth Ground to an EX4100-F Switch](#)" on page 140.

You install the power supply in the power supply slot on the rear panel of the switch.

To connect AC power to the switch:

1. On the rear panel of the switch, push the end of the power cord retainer strip into the slot above the power cord inlet until the strip snaps into place. Ensure that the loop in the retainer strip faces the power cord (see [Figure 108 on page 144](#)).

The power cord retainer clip extends out of the chassis by 3 in. (7.62 cm).

2. Press the small tab on the retainer strip to loosen the loop. Slide the loop until you have enough space to insert the power cord coupler into the power cord inlet.
3. Locate the power cord or cords shipped with the switch. The cords have plugs appropriate for your geographical location. See [Figure 109 on page 144](#).



WARNING: Ensure that the power cord does not block access to switch components and that it is secured to prevent people from tripping on it.

4. Insert the power cord coupler firmly into the power cord inlet (see [Figure 109 on page 144](#)).
5. Slide the loop toward the power supply until it is snug against the base of the coupler.
6. Press the tab on the loop and draw out the loop into a tight circle.
7. Push the power cord into the slot in the adjustment nut of the power cord retainer clip. Turn the nut until it is tight against the base of the coupler and the slot in the nut is turned 90° from the top of the switch. See [Figure 110 on page 144](#) and [Figure 111 on page 145](#).
8. If the AC power source outlet has a power switch, set it to the OFF (O) position.
9. Insert the power cord plug into an AC power source outlet.
10. If the AC power source outlet has a power switch, set it to the ON (I) position.

Figure 108: Connecting an AC Power Cord Retainer Clip to the AC Power Cord Inlet on an EX4100 Switch

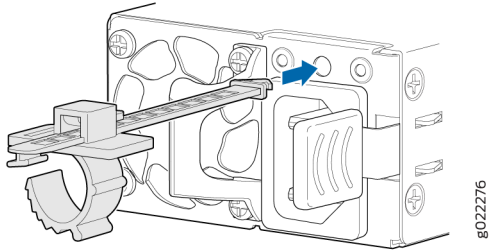

Figure 109: Connecting an AC Power Cord to the AC Power Cord Inlet of an EX4100 Switch

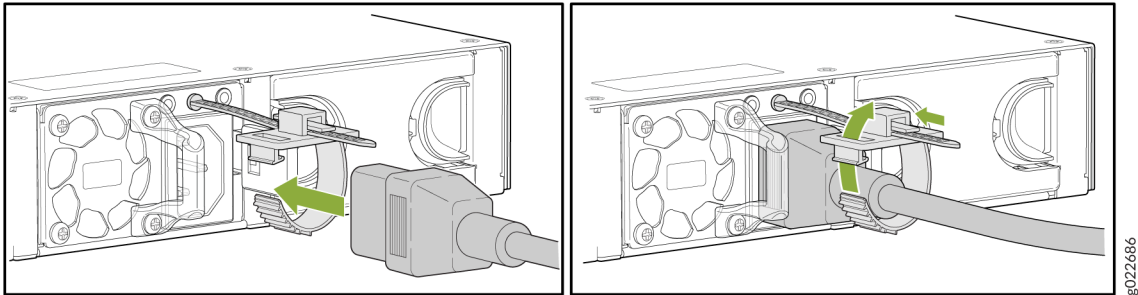

Figure 110: Fitting an Adjustment Nut to the AC Power Cord Retainer Clip on EX4100-F-24P, EX4100-F-24T, EX4100-F-48P, and EX4100-F-48T switches

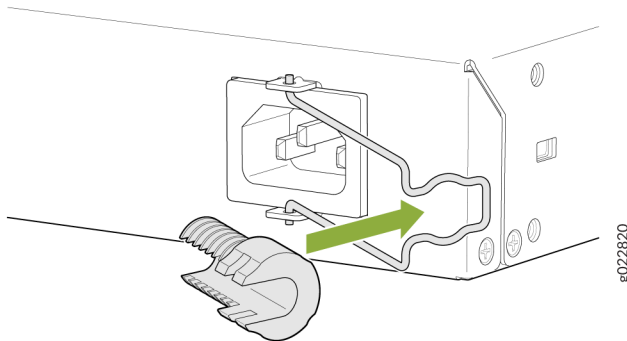
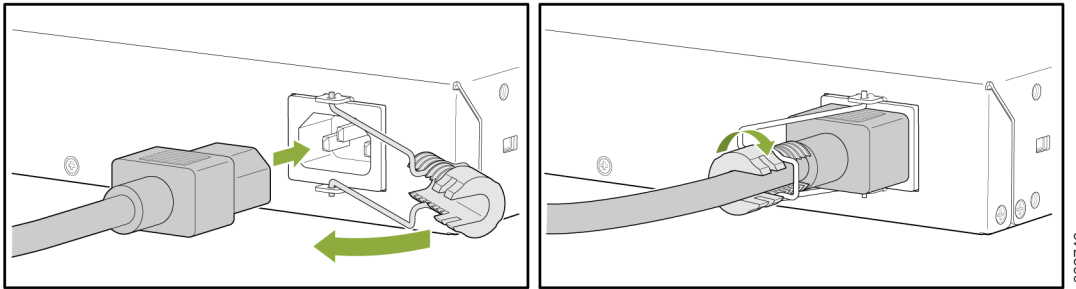

Figure 111: Connecting an AC Power Cord to the AC Power Cord Inlet on EX4100-F-24P, EX4100-F-24T, EX4100-F-48P, and EX4100-F-48T switches



Connect AC power to an EX4100-F-12P and EX4100-F-12T Switch

Before you connect power to the switch, ensure that you have the following parts and tools available:

- A power cord appropriate for your geographical location
- A power cord retainer clip (provided with the switch)

Ensure that you have connected the device chassis to earth ground. The AC power cords also provide additional grounding when you connect the power supply in the switch to a grounded AC power outlet by using the AC power cord appropriate for your geographical location (see [No Link Title](#)).



CAUTION: For installations that require a separate grounding conductor to the chassis, have a licensed electrician complete this connection before you connect the switch to power. For instructions on connecting earth ground, see ["Connect Earth Ground to an EX4100-F Switch" on page 140](#).

To connect AC power to an EX4100-F-12P and EX400-F-12T switch:

1. Push the end of the power cord retainer strip into the slot beside the power cord inlet until the strip snaps into place. See [Figure 112 on page 146](#).
2. Press the small tab on the retainer strip to loosen the loop. Slide the loop until you have enough space to insert the power cord coupler into the power cord inlet. See [Figure 112 on page 146](#).
3. Locate the power cord or cords shipped with the switch. The cords have plugs appropriate for your geographical location.



WARNING: Ensure that the power cord does not block access to switch components and that it is secured to prevent people from tripping on it.

4. Insert the power cord coupler firmly into the power cord inlet of the power supply adaptor. See [Figure 112 on page 146](#).

Figure 112: Connecting an AC Power Cord Retainer Clip to the AC Power Cord Inlet of an EX4100-F-12P and EX4100-F-12T Switch

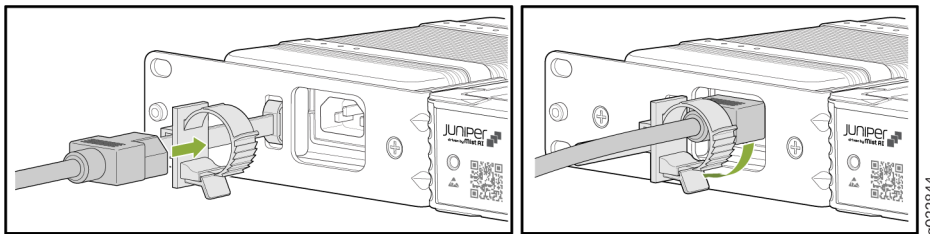

5. Slide the loop toward the power supply until it is snug against the base of the coupler. See [Figure 112 on page 146](#).
6. Press the tab on the loop and draw out the loop into a tight circle. See [Figure 112 on page 146](#).
7. Insert the power cord that is permanently attached to the power supply adaptor, to the DC inlet of the switch. See [Figure 113 on page 146](#) and [Figure 114 on page 147](#).

Figure 113: Connect Power Supply Adaptor to DC Inlet of the EX4100-F-12P Switch

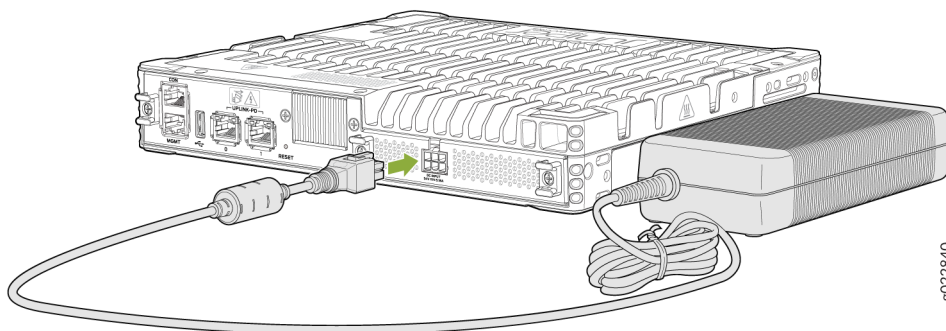
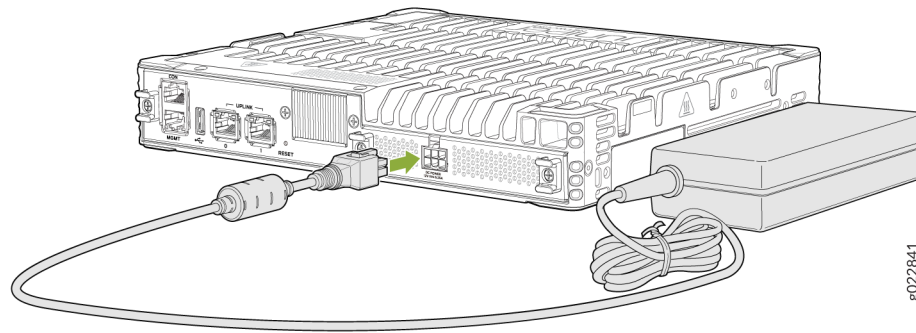

Figure 114: Connect Power Supply Adaptor to DC Inlet of the EX4100-F-12T Switch



8. Switch off the AC power source outlet.
9. Insert the power cord plug of the power cord that was attached to the power inlet of the power supply adaptor, into the AC power source outlet.
10. Switch on the AC power source outlet.

Connect the EX4100-F Switch to External Devices

IN THIS SECTION

- [Connect a Device to a Network for Out-of-Band Management | 147](#)
- [Connect a Device to a Management Console Using an RJ-45 Connector | 148](#)
- [Connect an EX4100-F Switch to a Management Console Using the USB Type-C Console Port | 150](#)

Connect a Device to a Network for Out-of-Band Management

Ensure that you have an Ethernet cable that has an RJ-45 connector at either end. [Figure 115 on page 148](#) shows the RJ-45 connector of the Ethernet cable.

Figure 115: RJ-45 Connector on an Ethernet Cable

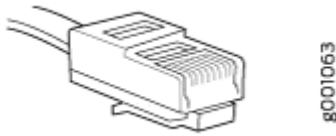

You can monitor and manage these devices by using a dedicated management channel. Each device has a management port to which you can connect an Ethernet cable with an RJ-45 connector. Use the management port to connect the device to the management device.

To connect a device to a network for out-of-band management (see [Figure 116 on page 148](#)):

1. Connect one end of the Ethernet cable to the management port on the device.
2. Connect the other end of the Ethernet cable to the management device.

Figure 116: Connect a Device to a Network for Out-of-Band Management

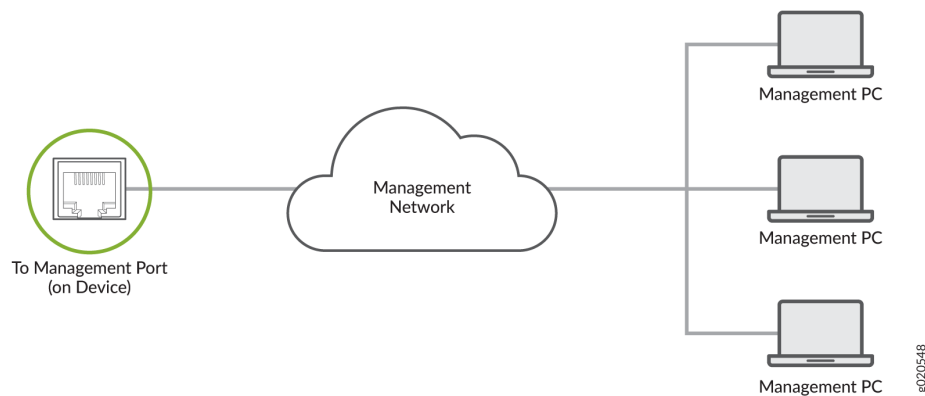

Connect a Device to a Management Console Using an RJ-45 Connector

Ensure that you have an Ethernet cable that has an RJ-45 connector at either end and an RJ-45-to-DB-9 serial port adapter.

[Figure 117 on page 149](#) shows the RJ-45 connector on the Ethernet cable.

Figure 117: RJ-45 Connector on an Ethernet Cable

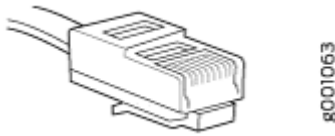

NOTE: We no longer include the RJ-45 console cable with the DB-9 adapter as part of the device package. If the console cable and adapter are not included in your device package, or if you need a different type of adapter, you can order the following separately:

- RJ-45 to DB-9 adapter (JNP-CBL-RJ45-DB9)
- RJ-45 to USB-A adapter (JNP-CBL-RJ45-USBA)
- RJ-45 to USB-C adapter (JNP-CBL-RJ45-USBC)

If you want to use RJ-45 to USB-A or RJ-45 to USB-C adapter you must have X64 (64-Bit) Virtual COM port (VCP) driver installed on your PC. See, <https://ftdichip.com/drivers/vcp-drivers/> to download the driver.

NOTE: If your laptop or desktop PC does not have a DB-9 plug connector pin and you want to connect your laptop or desktop PC directly to the device, use a combination of the RJ-45-to-DB-9 socket adapter and a USB-to-DB-9 plug adapter. You must provide the USB-to-DB-9 plug adapter.

You can configure and manage your network devices using a dedicated management channel. Each device has a console port that you can connect to using an Ethernet cable with an RJ-45 connector. Use the console port to connect the device to the console server or management console. The console port accepts a cable that has an RJ-45 connector.

To connect the device to a management console (see [Figure 118 on page 150](#) and [Figure 119 on page 150](#)):

1. Connect one end of the Ethernet cable to the console port (labeled **CON**, **CONSOLE**, or **CON1**) on the device.
2. Connect the other end of the Ethernet cable to the console server (see [Figure 118 on page 150](#)) or management console (see [Figure 119 on page 150](#)).

Figure 118: Connect a Device to a Management Console Through a Console Server

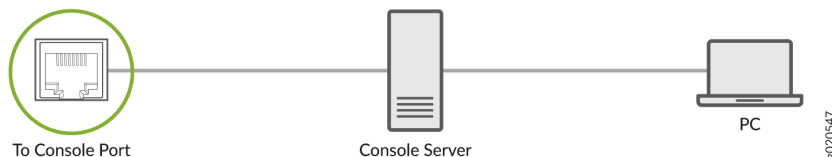
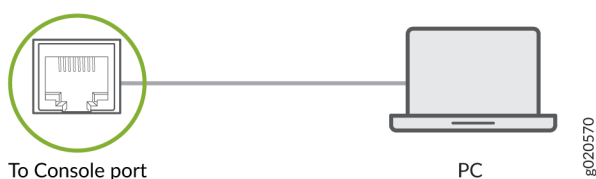

Figure 119: Connect a Device Directly to a Management Console



Connect an EX4100-F Switch to a Management Console Using the USB Type-C Console Port

Before You Begin

Before you connect the switch using the USB Type-C console port:

- Ensure that the USB to serial driver is installed on the host machine.
- Ensure that the HyperTerminal properties of the console server or laptop are set as follows:
 - Baud rate—9600
 - Flow control—None
 - Data—8
 - Parity—None
 - Stop bits—1
 - DCD state—Disregard

You will need:

- One USB cable with USB Type-C connectors at both ends (not provided).

- (If your laptop or desktop PC does not have a USB Type-C port) One USB Type-A to USB Type-C converter cable (not provided).

EX4100-F switches have two console ports:

- An RJ-45 console port on the rear panel that accepts a cable with an RJ-45 connector
- A USB Type-C console port on the front panel that accepts a USB cable with a USB Type-C connector

You can log in to the switch and configure and manage the switch by using either of the console ports. The RJ-45 console port is enabled by default. However, you must configure the USB Type-C console port before you can use it to connect to the switch.

In this topic, you learn how to connect EX4100-F switches to the management console using the USB Type-C console port.

To connect the switch to the console using the USB Type-C console port:

1. Connect the host machine to the device directly. You can use the active console port or use the management interface to connect remotely.
2. Connect one end of the USB cable to the USB Type-C or Type-A port your PC or laptop.
3. Connect the other end of the USB cable to the USB Type-C console port on the front panel switch.
4. Use the `set system ports auxiliary type ansi configuration` command to enable login (to the switch) using the USB Type-C console port.
5. Use the `request system boot-console auxiliary` command to see the boot logs on the console connected to the USB Type-C port.

Note that only the Junos OS boot logs will be visible on the USB Type-C console.

6. Reboot the switch. The boot logs and the login prompt appear on the console connected to the USB Type-C port.

Connect the EX4100-F Switch to the Network

IN THIS SECTION

- [Install a Transceiver | 152](#)
- [Connect a Fiber-Optic Cable | 155](#)

Install a Transceiver

Before you install a transceiver in a device, ensure that you have taken the necessary precautions for safe handling of lasers (see [Laser and LED Safety Guidelines and Warnings](#)).

Ensure that you have a rubber safety cap available to cover the transceiver.

The transceivers for Juniper Networks devices are hot-removable and hot-insertable field-replaceable units (FRUs). You can remove and replace the transceivers without powering off the device or disrupting the device functions.

NOTE: After you insert a transceiver or after you change the media-type configuration, wait for 6 seconds for the interface to display operational commands.

NOTE: We recommend that you use only optical transceivers and optical connectors purchased from Juniper Networks with your Juniper Networks device.



CAUTION: The Juniper Networks Technical Assistance Center (JTAC) provides complete support for Juniper-supplied optical modules and cables. However, JTAC does not provide support for third-party optical modules and cables that are not qualified or supplied by Juniper Networks. If you face a problem running a Juniper device that uses third-party optical modules or cables, JTAC may help you diagnose host-related issues if the observed issue is not, in the opinion of JTAC, related to the use of the third-party optical modules or cables. Your JTAC engineer will likely request that you check the third-party optical module or cable and, if required, replace it with an equivalent Juniper-qualified component.

Use of third-party optical modules with high-power consumption (for example, coherent ZR or ZR+) can potentially cause thermal damage to or reduce the lifespan of the host equipment. Any damage to the host equipment due to the use of third-party optical modules or cables is the users' responsibility. Juniper Networks will accept no liability for any damage caused due to such use.

[Figure 120 on page 155](#) shows how to install a QSFP+ transceiver. The procedure is the same for all types of transceivers except the QSFP28 and CFP transceivers.

To install a transceiver:



CAUTION: To prevent electrostatic discharge (ESD) damage to the transceiver, do not touch the connector pins at the end of the transceiver.

1. Wrap and fasten one end of the ESD wrist strap around your bare wrist, and connect the other end of the strap to the ESD point on the switch.
2. Remove the transceiver from its bag.
3. Check to see whether the transceiver is covered with a rubber safety cap. If it is not, cover the transceiver with a rubber safety cap.



LASER WARNING: Do not leave a fiber-optic transceiver uncovered except when inserting or removing a cable. The rubber safety cap keeps the port clean and protects your eyes from accidental exposure to laser light.

4. If the port in which you want to install the transceiver is covered with a dust cover, remove the dust cover and save it in case you need to cover the port later. If you are hot-swapping a transceiver, wait for at least 10 seconds after removing the transceiver from the port before installing a new transceiver.
5. Using both hands, carefully place the transceiver in the empty port. The connectors must face the chassis.



CAUTION: Before you slide the transceiver into the port, ensure that the transceiver is aligned correctly. Misalignment might cause the pins to bend, making the transceiver unusable.

6. Slide the transceiver in gently until it is fully seated. If you are installing a CFP transceiver, use your fingers to tighten the captive screws on the transceiver.
7. Remove the rubber safety cap from the transceiver and the end of the cable, and insert the cable into the transceiver.



LASER WARNING: Do not look directly into a fiber-optic transceiver or into the ends of fiber-optic cables. Fiber-optic transceivers and fiber-optic cable connected to a transceiver emit laser light that can damage your eyes.



CAUTION: Do not leave a fiber-optic transceiver uncovered except when inserting or removing cable. The safety cap keeps the port clean and protects your eyes from accidental exposure to laser light.

8. If there is a cable management system, arrange the cable in the cable management system to prevent the cable from dislodging or developing stress points. Secure the cable so that it does not support its own weight as it hangs toward the floor. Place excess cable out of the way in a neatly coiled loop in the cable management system. Placing fasteners on the loop helps to maintain its shape.



CAUTION: Do not let fiber-optic cable hang free from the connector. Do not allow fastened loops of cable to dangle, which stresses the cable at the fastening point.



CAUTION: Avoid bending fiber-optic cable beyond its minimum bend radius. An arc smaller than a few inches in diameter can damage the cable and cause problems that are difficult to diagnose.

NOTE: When you install SFP-DD transceivers, push it hard until you hear a click sound. Use a long nose plier to pull the SFP-DD transceiver connected on the top and bottom rows of the chassis where the pull tabs face each other.

NOTE: Make sure to use a dust cap to cover ports that are unused.

NOTE: While using Finisar AOC SFP+ optical module with the QFX5130-48C switch, you may need to pull the module upwards to pull out the module smoothly from the cage.

NOTE: "

Figure 120: Install a Transceiver

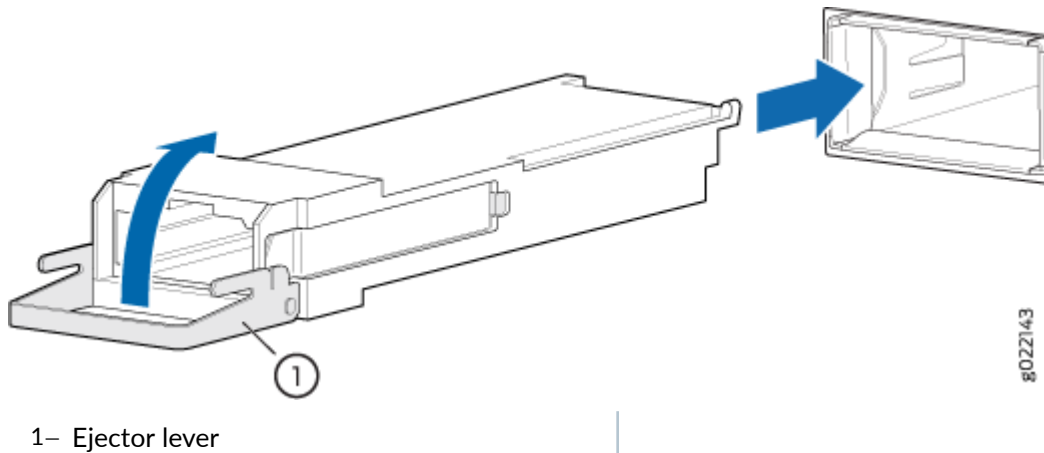

Connect a Fiber-Optic Cable

Before you connect a fiber-optic cable to an optical transceiver installed in a device, ensure that you have taken the necessary precautions for safe handling of lasers (see *Laser and LED Safety Guidelines and Warnings*).

To connect a fiber-optic cable to an optical transceiver installed in a device:



LASER WARNING: Do not look directly into a fiber-optic transceiver or into the ends of fiber-optic cables. Fiber-optic transceivers and fiber-optic cables connected to transceivers emit laser light that can damage your eyes.

1. If the fiber-optic cable connector is covered with a rubber safety cap, remove the cap. Save the cap.
2. Remove the rubber safety cap from the optical transceiver. Save the cap.
3. Insert the cable connector into the optical transceiver (see [Figure 121 on page 155](#)).

Figure 121: Connect a Fiber-Optic Cable to an Optical Transceiver Installed in a Device

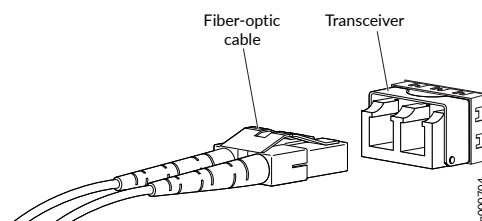

4. Secure the cables so that they do not support their own weight. Place excess cable out of the way in a neatly coiled loop. Placing fasteners on a loop helps cables maintain their shape.



CAUTION: Do not bend fiber-optic cables beyond their minimum bend radius. An arc smaller than a few inches in diameter can damage the cables and cause problems that are difficult to diagnose.

Do not let fiber-optic cables hang free from the connector. Do not allow fastened loops of cables to dangle, which stresses the cables at the fastening point.

Configure Junos OS on an EX4100-F Switch

IN THIS SECTION

- [EX4100-F Default Configuration | 156](#)
- [Connect and Configure an EX4100-F Switch | 172](#)
- [Revert to the Default Factory Configuration on an EX Series Switch | 178](#)

EX4100-F Default Configuration

Each EX Series switch is programmed with a factory default configuration that contains the values set for each configuration parameter when the switch is shipped. The default configuration file sets values for system parameters such as `syslog` and `commit`, configures Ethernet switching on all interfaces, enables IGMP snooping, and enables the LLDP and RSTP protocols.

NOTE:

- The factory default configuration file has more interfaces for models that have more ports.

- The `poe` statement does not appear for models without PoE+ ports.

When you commit changes to the configuration, a new configuration file is created. This file becomes the active configuration. You can always revert to the factory-default configuration. See ["Revert to the Default Factory Configuration on an EX Series Switch" on page 178](#).

The following is the factory-default configuration file for an EX4100-48P switch:

```
system {
  commit {
    factory-settings {
      reset-chassis-lcd-menu;
      reset-virtual-chassis-configuration;
    }
  }
  services {
    ssh;
    netconf {
      ssh;
      rfc-compliant;
      yang-compliant;
    }
  }
  auto-snapshot;
  syslog {
    file interactive-commands {
      interactive-commands any;
    }
  }
  file messages {
    any notice;
    authorization info;
  }
  processes {
    dhcp-service {
      traceoptions {
        file dhcp_logfile size 10m;
        level all;
        flag packet;
      }
    }
  }
}
```

```
    }
  }
  phone-home {
    server https://redirect.juniper.net;
    rfc-compliant;
  }
  ## Warning: missing mandatory statement(s): 'root-authentication'
}
chassis {
  redundancy {
    graceful-switchover;
  }
  auto-image-upgrade;
}
interfaces {
  ge-0/0/0 {
    unit 0 {
      family ethernet-switching {
        storm-control default;
      }
    }
  }
  ge-0/0/1 {
    unit 0 {
      family ethernet-switching {
        storm-control default;
      }
    }
  }
  ge-0/0/2 {
    unit 0 {
      family ethernet-switching {
        storm-control default;
      }
    }
  }
  ge-0/0/3 {
    unit 0 {
      family ethernet-switching {
        storm-control default;
      }
    }
  }
}
```

```
ge-0/0/4 {
  unit 0 {
    family ethernet-switching {
      storm-control default;
    }
  }
}
ge-0/0/5 {
  unit 0 {
    family ethernet-switching {
      storm-control default;
    }
  }
}
ge-0/0/6 {
  unit 0 {
    family ethernet-switching {
      storm-control default;
    }
  }
}
ge-0/0/7 {
  unit 0 {
    family ethernet-switching {
      storm-control default;
    }
  }
}
ge-0/0/8 {
  unit 0 {
    family ethernet-switching {
      storm-control default;
    }
  }
}
ge-0/0/9 {
  unit 0 {
    family ethernet-switching {
      storm-control default;
    }
  }
}
ge-0/0/10 {
```



```
unit 0 {
    family ethernet-switching {
        storm-control default;
    }
}
ge-0/0/11 {
    unit 0 {
        family ethernet-switching {
            storm-control default;
        }
    }
}
ge-0/0/12 {
    unit 0 {
        family ethernet-switching {
            storm-control default;
        }
    }
}
ge-0/0/13 {
    unit 0 {
        family ethernet-switching {
            storm-control default;
        }
    }
}
ge-0/0/14 {
    unit 0 {
        family ethernet-switching {
            storm-control default;
        }
    }
}
ge-0/0/15 {
    unit 0 {
        family ethernet-switching {
            storm-control default;
        }
    }
}
ge-0/0/16 {
    unit 0 {
```

```
        family ethernet-switching {
            storm-control default;
        }
    }
ge-0/0/17 {
    unit 0 {
        family ethernet-switching {
            storm-control default;
        }
    }
ge-0/0/18 {
    unit 0 {
        family ethernet-switching {
            storm-control default;
        }
    }
ge-0/0/19 {
    unit 0 {
        family ethernet-switching {
            storm-control default;
        }
    }
ge-0/0/20 {
    unit 0 {
        family ethernet-switching {
            storm-control default;
        }
    }
ge-0/0/21 {
    unit 0 {
        family ethernet-switching {
            storm-control default;
        }
    }
ge-0/0/22 {
    unit 0 {
        family ethernet-switching {
```

```
        storm-control default;
    }
}
ge-0/0/23 {
    unit 0 {
        family ethernet-switching {
            storm-control default;
        }
    }
}
ge-0/0/24 {
    unit 0 {
        family ethernet-switching {
            storm-control default;
        }
    }
}
ge-0/0/25 {
    unit 0 {
        family ethernet-switching {
            storm-control default;
        }
    }
}
ge-0/0/26 {
    unit 0 {
        family ethernet-switching {
            storm-control default;
        }
    }
}
ge-0/0/27 {
    unit 0 {
        family ethernet-switching {
            storm-control default;
        }
    }
}
ge-0/0/28 {
    unit 0 {
        family ethernet-switching {
            storm-control default;
```

```
    }
  }
}
ge-0/0/29 {
  unit 0 {
    family ethernet-switching {
      storm-control default;
    }
  }
}
ge-0/0/30 {
  unit 0 {
    family ethernet-switching {
      storm-control default;
    }
  }
}
ge-0/0/31 {
  unit 0 {
    family ethernet-switching {
      storm-control default;
    }
  }
}
ge-0/0/32 {
  unit 0 {
    family ethernet-switching {
      storm-control default;
    }
  }
}
ge-0/0/33 {
  unit 0 {
    family ethernet-switching {
      storm-control default;
    }
  }
}
ge-0/0/34 {
  unit 0 {
    family ethernet-switching {
      storm-control default;
    }
  }
}
```

```
        }
    }
    ge-0/0/35 {
        unit 0 {
            family ethernet-switching {
                storm-control default;
            }
        }
    }
    ge-0/0/36 {
        unit 0 {
            family ethernet-switching {
                storm-control default;
            }
        }
    }
    ge-0/0/37 {
        unit 0 {
            family ethernet-switching {
                storm-control default;
            }
        }
    }
    ge-0/0/38 {
        unit 0 {
            family ethernet-switching {
                storm-control default;
            }
        }
    }
    ge-0/0/39 {
        unit 0 {
            family ethernet-switching {
                storm-control default;
            }
        }
    }
    ge-0/0/40 {
        unit 0 {
            family ethernet-switching {
                storm-control default;
            }
        }
    }
```

```
    }
ge-0/0/41 {
  unit 0 {
    family ethernet-switching {
      storm-control default;
    }
  }
}
ge-0/0/42 {
  unit 0 {
    family ethernet-switching {
      storm-control default;
    }
  }
}
ge-0/0/43 {
  unit 0 {
    family ethernet-switching {
      storm-control default;
    }
  }
}
ge-0/0/44 {
  unit 0 {
    family ethernet-switching {
      storm-control default;
    }
  }
}
ge-0/0/45 {
  unit 0 {
    family ethernet-switching {
      storm-control default;
    }
  }
}
ge-0/0/46 {
  unit 0 {
    family ethernet-switching {
      storm-control default;
    }
  }
}
```

```
ge-0/0/47 {
  unit 0 {
    family ethernet-switching {
      storm-control default;
    }
  }
}
et-0/1/0 {
  unit 0 {
    family ethernet-switching {
      storm-control default;
    }
  }
}
ge-0/1/0 {
  unit 0 {
    family ethernet-switching {
      storm-control default;
    }
  }
}
xe-0/1/0 {
  unit 0 {
    family ethernet-switching {
      storm-control default;
    }
  }
}
et-0/1/1 {
  unit 0 {
    family ethernet-switching {
      storm-control default;
    }
  }
}
ge-0/1/1 {
  unit 0 {
    family ethernet-switching {
      storm-control default;
    }
  }
}
xe-0/1/1 {
```

```
    unit 0 {
        family ethernet-switching {
            storm-control default;
        }
    }
}
et-0/1/2 {
    unit 0 {
        family ethernet-switching {
            storm-control default;
        }
    }
}
ge-0/1/2 {
    unit 0 {
        family ethernet-switching {
            storm-control default;
        }
    }
}
xe-0/1/2 {
    unit 0 {
        family ethernet-switching {
            storm-control default;
        }
    }
}
et-0/1/3 {
    unit 0 {
        family ethernet-switching {
            storm-control default;
        }
    }
}
ge-0/1/3 {
    unit 0 {
        family ethernet-switching {
            storm-control default;
        }
    }
}
xe-0/1/3 {
    unit 0 {
```



```
        family ethernet-switching {
            storm-control default;
        }
    }
}
ge-0/2/0 {
    unit 0 {
        family ethernet-switching {
            storm-control default;
        }
    }
}
xe-0/2/0 {
    unit 0 {
        family ethernet-switching {
            storm-control default;
        }
    }
}
ge-0/2/1 {
    unit 0 {
        family ethernet-switching {
            storm-control default;
        }
    }
}
xe-0/2/1 {
    unit 0 {
        family ethernet-switching {
            storm-control default;
        }
    }
}
ge-0/2/2 {
    unit 0 {
        family ethernet-switching {
            storm-control default;
        }
    }
}
xe-0/2/2 {
    unit 0 {
        family ethernet-switching {
```

```
        storm-control default;
        }
    }
}
ge-0/2/3 {
    unit 0 {
        family ethernet-switching {
            storm-control default;
        }
    }
}
xe-0/2/3 {
    unit 0 {
        family ethernet-switching {
            storm-control default;
        }
    }
}
irb {
    unit 0 {
        family inet {
            dhcp {
                vendor-id Juniper-ex4100-48p-FA1422AN0045;
            }
        }
    }
}
family inet6 {
    dhcpv6-client {
        client-type stateful;
        client-ia-type ia-na;
        client-identifier duid-type duid-ll;
        vendor-id Juniper:ex4100-48p:FA1422AN0045;
    }
}
vme {
    unit 0 {
        family inet {
            dhcp {
                vendor-id Juniper-ex4100-48p-FA1422AN0045;
            }
        }
    }
}
family inet6 {
```

```
        dhcpv6-client {
            client-type stateful;
            client-ia-type ia-na;
            client-identifier duid-type duid-ll;
            vendor-id Juniper:ex4100-48p:FA1422AN0045;
        }
    }
}

forwarding-options {
    storm-control-profiles default {
        all;
    }
}

protocols {
    router-advertisement {
        interface vme.0 {
            managed-configuration;
        }
    }
    interface irb.0 {
        managed-configuration;
    }
}

lldp {
    interface all;
}

lldp-med {
    interface all;
}

igmp-snooping {
    vlan default;
}

rstp {
    interface ge-0/0/0;
    interface ge-0/0/1;
    interface ge-0/0/2;
    interface ge-0/0/3;
    interface ge-0/0/4;
    interface ge-0/0/5;
    interface ge-0/0/6;
    interface ge-0/0/7;
    interface ge-0/0/8;
```

```
interface ge-0/0/9;  
interface ge-0/0/10;  
interface ge-0/0/11;  
interface ge-0/0/12;  
interface ge-0/0/13;  
interface ge-0/0/14;  
interface ge-0/0/15;  
interface ge-0/0/16;  
interface ge-0/0/17;  
interface ge-0/0/18;  
interface ge-0/0/19;  
interface ge-0/0/20;  
interface ge-0/0/21;  
interface ge-0/0/22;  
interface ge-0/0/23;  
interface ge-0/0/24;  
interface ge-0/0/25;  
interface ge-0/0/26;  
interface ge-0/0/27;  
interface ge-0/0/28;  
interface ge-0/0/29;  
interface ge-0/0/30;  
interface ge-0/0/31;  
interface ge-0/0/32;  
interface ge-0/0/33;  
interface ge-0/0/34;  
interface ge-0/0/35;  
interface ge-0/0/36;  
interface ge-0/0/37;  
interface ge-0/0/38;  
interface ge-0/0/39;  
interface ge-0/0/40;  
interface ge-0/0/41;  
interface ge-0/0/42;  
interface ge-0/0/43;  
interface ge-0/0/44;  
interface ge-0/0/45;  
interface ge-0/0/46;  
interface ge-0/0/47;  
interface et-0/1/0;  
interface ge-0/1/0;  
interface xe-0/1/0;  
interface et-0/1/1;
```

```

        interface ge-0/1/1;
        interface xe-0/1/1;
        interface et-0/1/2;
        interface ge-0/1/2;
        interface xe-0/1/2;
        interface et-0/1/3;
        interface ge-0/1/3;
        interface xe-0/1/3;
        interface ge-0/2/0;
        interface xe-0/2/0;
        interface ge-0/2/1;
        interface xe-0/2/1;
        interface ge-0/2/2;
        interface xe-0/2/2;
        interface ge-0/2/3;
        interface xe-0/2/3;
    }
}

poe {
    interface all;
}

vlans {
    default {
        vlan-id 1;
        l3-interface irb.0;
    }
}
}

```

Connect and Configure an EX4100-F Switch

Before you connect and configure an EX4100-F switch, set the following parameter values on the console server or PC:

- Baud Rate—9600
- Data—8
- Flow Control—None
- Parity—None
- Stop Bits—1

- DCD State—Disregard

Ensure that you have the following parts and tools available:

- An Ethernet cable with an RJ-45 connector attached (not provided)
- An RJ-45 to DB-9 serial port adapter (not provided)
- A laptop or PC, with a serial port (not provided)

NOTE: We no longer include the RJ-45 console cable with the DB-9 adapter as part of the device package. If the console cable and adapter are not included in your device package, or if you need a different type of adapter, you can order the following separately:

- RJ-45 to DB-9 adapter (JNP-CBL-RJ45-DB9)
- RJ-45 to USB-A adapter (JNP-CBL-RJ45-USBA)
- RJ-45 to USB-C adapter (JNP-CBL-RJ45-USBC)

If you want to use RJ-45 to USB-A or RJ-45 to USB-C adapter you must have X64 (64-Bit) Virtual COM port (VCP) driver installed on your PC. See, <https://ftdichip.com/drivers/vcp-drivers/> to download the driver.

Have the following information available before you configure custom settings for the switch:

- Root password
- IP address of the default gateway
- IP address of the management port
- IP address of a DNS server
- (Optional) Hostname
- (Optional) IP address of a backup router
- (Optional) SNMP read community, location, and contact to configure SNMP parameters
- (Optional) Static routes to remote subnets with access to the management port
- (Optional) Static routes to remote prefixes with access to the management port

An EX4100-F switch is shipped with Junos OS preinstalled and ready to be configured when the switch is powered on. You must perform the initial configuration of the switch through the console port (labeled **CON**) on the rear panel of the switch by using the CLI.

This procedure describes how to perform the initial configuration on the switch and connect it to the network. For complete information about enabling the switch to forward traffic, including examples, see the Junos OS configuration guides.

To perform the initial configuration on the switch and connect it to the network:

1. Power the switch on.
2. Connect the console port (labeled **CON**) on the rear panel of the switch to a management host such as a laptop or PC by using an RJ-45-to-DB-9 serial port adapter.
3. At the Junos OS login prompt, type **root** to log in. You don't need to enter a password. If the software booted before you connected the console port, you might need to press the Enter key for the prompt to appear.

```
login: root
```

4. Start the CLI.

```
root@RE:0% cli  
root>
```

5. Enter configuration mode.

```
root> configure  
[edit]  
root#
```

6. Add a password to the root administration user account. Enter a clear-text password, an encrypted password, or an SSH public key string.

```
[edit]  
root# set system root-authentication plain-text-password  
New password: password  
Retype new password: password
```

or

```
[edit]  
root# set system root-authentication encrypted-password encrypted-password
```

or

```
[edit]
root# set system root-authentication ssh-ecdsa public-key
```

or

```
[edit]
root# set system root-authentication ssh-ed25519 public-key
```

or

```
[edit]
root# set system root-authentication ssh-rsa public-key
```

7. (Optional) Configure the hostname of the switch. If the name includes spaces, enclose the name in double quotation marks (" ").

```
[edit]
root# set system host-name host-name
```

8. (Optional) Create a user account.

```
[edit]
root# set system login user user-name authentication plain-text-password
New password: password
Retype new password: password
```

9. (Optional) Set the user account class to super-user.

```
[edit]
root# set system login user user-name class super-user
```

10. (Optional) Configure the domain name of the switch.

```
[edit]
root# set system domain-name domain-name
```

11. Configure the default gateway.

```
[edit]
root# set routing-options static route 0/0 next-hop address
```

12. Configure the IP address and prefix length for the management interface on the switch.

```
[edit]
root# set interfaces vme unit 0 family inet address address/prefix-length
```

NOTE: The management port `vme` (labeled **MGMT**) is located on the rear panel of the switch.

13. (Optional) Configure the IP address of a backup router, which is used only while the routing protocol is not running.

```
[edit]
root# set system backup-router address
```

14. Configure the IP address of a DNS server.

```
[edit]
root# set system name-server address
```

15. (Optional) Configure the static routes to remote subnets with access to the management port. Access to the management port is limited to the local subnet.

```
[edit]
root# set routing-options static route remote-subnet next-hop destination-IP retain no-
readvertise
```

16. (Optional) Configure the static routes to remote prefixes with access to the management port.

```
[edit]
root# set routing-options static route remote-prefix next-hop destination-IP retain no-
readvertise
```

17. Configure the SSH service.

```
[edit]
root# set system services ssh root-login allow
```

18. Configure in-band management or out-of-band management:

- With in-band management, you can configure a network port interface as the management interface and connect it to the management device. In this scenario, you can do either of the following:
 - Use the automatically created VLAN named *default* for management of all data interfaces as members of the default VLAN. Specify the management IP address and the default gateway.
 - Create a new management VLAN. Specify the VLAN name, VLAN ID, management IP address, and default gateway. Select the ports that must be part of this VLAN.
- With out-of-band management, you use a dedicated management channel (**MGMT**, **C0**, or **C1** port) to connect to the management device. Specify the IP address and gateway of the management interface. Use this IP address to connect to the switch.

19. (Optional) Specify the SNMP read community, location, and contact to configure SNMP parameters.

20. (Optional) Specify the system date and time. Select the time zone from the list. The configured parameters are displayed.

21. Enter **yes** to commit the configuration. The configuration is committed as the active configuration for the switch.

22. (Optional) Configure additional properties by adding the necessary configuration statements.

23. Commit the configuration to activate it on the switch.

```
[edit]
root# commit
```

24. When you have finished configuring the switch, exit configuration mode.

```
[edit]
root@switch# exit
root@switch>
```

You can now log in by using the CLI and continue configuring the switch.

Revert to the Default Factory Configuration on an EX Series Switch

IN THIS SECTION

- [Revert to the EX Series Switch Factory-Default Configuration Using the `request system zeroize` Command | 179](#)
- [Revert to the EX Series Switch Factory-Default Configuration Using the `load factory-default` Command | 179](#)
- [Revert to the Factory-Default Configuration Using the Factory Reset/Port Mode button | 180](#)

With EX Series switches, if for any reason the current active configuration fails, you can revert to the factory-default configuration.

You can also roll back to a previous configuration, as described in [Rolling Back Junos OS Configuration Changes](#), or revert to the rescue configuration, as described in [Reverting to the Rescue Configuration for the EX Series Switch](#).

TIP: If you have lost the root password, it is not necessary to revert to the factory-default configuration to reset it. See [Recovering the Root Password on Switches](#).

The factory-default configuration contains the basic configuration settings for the switch. This is the first configuration of the switch and is loaded when the switch is first powered on. For the factory-default configuration file for your switch, see the hardware documentation for your switch.

TIP: On fixed-configuration switches, you can run the EZsetup script to complete the initial configuration *after* reverting to the factory-default configuration. (The EZsetup script is not available on modular switches. To configure modular switches, use the CLI or the J-Web interface.) For information about completing the initial configuration using either the CLI or the J-Web interface, see *Connecting and Configuring an EX Series Switch (CLI Procedure)* or *Connecting and Configuring an EX Series Switch (J-Web Procedure)*.

You can revert to the factory-default configuration by using the `request system zeroize` operational command or the `load factory-default` configuration command to revert to the factory-default configuration file that contains all default settings *except* the root password setting, which is retained.

These procedures are described in the following sections:

Revert to the EX Series Switch Factory-Default Configuration Using the `request system zeroize` Command

The `request system zeroize` command is a standard Junos OS operational mode command that removes all configuration information and resets all key values. The operation unlinks all user-created data files, including customized configuration and log files, from their directories. The switch then reboots and reverts to the factory-default configuration.

To completely erase user-created data so that it is unrecoverable, use the `request system zeroize media` command.



CAUTION: Before issuing `request system zeroize`, use the `request system snapshot` command to back up the files currently used to run the switch to a secondary device. Using the `zeroize` command will destroy Junos and OAM partitions, and the switch may not boot. To recover from a failed software installation, see [Recovering from a Failed Software Installation](#).

To revert to the factory-default configuration by using the `request system zeroize` command:

1.

```
user@switch>request system zeroize warning: System will be rebooted and may not boot without
configuration
Erase all data, including configuration and log files?. In case of Dual RE system, both
Routing Engines will be zeroized [yes,no] (no)
```

2. Type `yes` to remove configuration and log files and revert to the factory-default configuration.

NOTE: The `auto-image-upgrade` statement is added under the `[edit chassis]` hierarchy level when you use this procedure. The automatic image upgrade feature is then available on the switch.

Revert to the EX Series Switch Factory-Default Configuration Using the `load factory-default` Command

The `load factory-default` command is a standard Junos OS configuration command that replaces the current active configuration with the factory-default configuration except the root password setting. By default, the root password is not set; you must set it to commit the new configuration in this procedure.

If you want to run the `EZsetup` script to complete the initial configuration of the switch after you revert to the factory-default configuration, do not use the `load factory-default` command. Instead, revert using the `request system zeroize` command. If you use the `load factory-default` command to revert to the factory-default configuration, the configuration for the root password is retained and the `EZsetup` script will not

run. (The EZsetup script is available only on fixed configuration switches, it is not available on modular switches.)

NOTE: The `load factory-default` command by itself is not supported on EX3300, EX4200, EX4500, and EX4550 switches configured in a Virtual Chassis.

To revert to the factory-default configuration by using the `load factory-default` command:

NOTE: If you use this procedure, you must delete the system commit factory settings, set the root password, and commit the configuration. These steps are not required when you revert to the factory-default configuration by using `request system zeroize`. Also, the `auto-image-upgrade` statement is not added to the configuration when you use this procedure; it *is* added to the configuration when you use `request system zeroize`.

1. [edit] user@switch# `load factory-default`
2. [edit] user@switch# `delete system commit factory-settings`
3. [edit] user@switch# `set system root-authentication plain-text-password`
4. [edit] user@switch# `commit`
5. Check the member ID and primary-role priority with the `show virtual-chassis` command and check to see whether there are remaining settings for VCPs by using the `show virtual-chassis vc-port` command.
6. Check for remaining settings for VCPs by using the `show virtual-chassis vc-port` command.

Revert to the Factory-Default Configuration Using the Factory Reset/Port Mode button

To set the switches to the factory-default configuration, use the Factory Reset/Mode button located on the far right side of the front panel.

NOTE: To revert a member switch of a Virtual Chassis to the factory-default configuration, disconnect the cables connected to the Virtual Chassis ports (VCPs). You disconnect the cables to prevent any effect on Virtual Chassis configuration parameters (such as member ID, primary-role priority, and setting of VCP uplinks) on other members (see *Disconnect a Fiber-Optic Cable*).

To revert to the factory-default configuration by using the Factory Reset/Mode button:

1. Press the Factory Reset/Mode button for 10 seconds. The switch transitions into factory-default configuration, the console displays **committing factory default configuration**, and the Link/Activity LED on the RJ-45 network ports and the uplink ports is lit steadily green.

2. Press the Factory Reset/Mode button for 10 more seconds. The switch transitions into initial setup mode, the console displays **committing ezsetup config**, and the Link/Activity LED on the RJ-45 network ports and the uplink ports blink green.

Note that you can also press the Factory Reset/Mode button continuously for 10 seconds + 10 seconds, totalling over 20 seconds to commit factory default configuration as well as commit ezsetup config.

The Factory Reset/Mode button is enabled by default. You can disable the button using the CLI.

To disable the Factory Reset/Mode button, run the following commands:

1. [edit]
user@switch# set chassis config-button no-clear
2. [edit]
user@switch# commit

To enable the Factory Reset/Mode button, run the following commands:

1. [edit]
user@switch# delete chassis config-button no-clear
2. [edit]
user@switch# commit

RELATED DOCUMENTATION

Connecting and Configuring an EX Series Switch (CLI Procedure)

Connecting and Configuring an EX Series Switch (J-Web Procedure)

[Understanding Configuration Files](#)

5

CHAPTER

Maintain Components

Maintain Transceivers | 183

Maintain Fiber-Optic Cables | 189

Maintain Transceivers

IN THIS SECTION

- [Remove a Transceiver | 183](#)
- [Install a Transceiver | 185](#)

Remove a Transceiver

Before you remove a transceiver from a device, ensure that you have taken the necessary precautions for the safe handling of lasers (see *Laser and LED Safety Guidelines and Warnings*).

Ensure that you have the following parts and tools available:

- An antistatic bag or an antistatic mat
- Rubber safety caps to cover the transceiver and fiber-optic cable connector
- A dust cover to cover the port or a replacement transceiver

The transceivers for Juniper Networks devices are hot-removable and hot-insertable field-replaceable units (FRUs). You can remove and replace the transceivers without powering off the device or disrupting device functions.

NOTE: After you remove a transceiver, or when you change the media-type configuration, wait for 6 seconds for the interface to display the operational commands.

[Figure 122 on page 185](#) shows how to remove a QSFP+ transceiver. The procedure is the same for all types of transceivers except the QSFP28 and CFP transceivers.

To remove a transceiver from a device:

1. Place the antistatic bag or antistatic mat on a flat, stable surface.
2. Wrap and fasten one end of the ESD wrist strap around your bare wrist, and connect the other end of the strap to the ESD point on the switch.

3. Label the cable connected to the transceiver so that you can reconnect it correctly.



LASER WARNING: Do not look directly into a fiber-optic transceiver or into the ends of fiber-optic cables. Fiber-optic transceivers and fiber-optic cables connected to transceivers emit laser light that can damage your eyes.



LASER WARNING: Do not leave a fiber-optic transceiver uncovered except when inserting or removing a cable. The rubber safety cap keeps the port clean and protects your eyes from accidental exposure to laser light.



CAUTION: Do not bend fiber-optic cables beyond their minimum bend radius. An arc smaller than a few inches in diameter can damage the cables and cause problems that are difficult to diagnose.

4. Remove the cable connected to the transceiver (see *Disconnect a Fiber-Optic Cable*). Cover the transceiver and the end of each fiber-optic cable connector with a rubber safety cap immediately after disconnecting the fiber-optic cables.
5. If there is a cable management system, arrange the cable in the cable management system to prevent it from dislodging or developing stress points. Secure the cable so that it does not support its own weight as it hangs to the floor. Place excess cable out of the way in a neatly coiled loop in the cable management system. Placing fasteners on the loop helps to maintain its shape.



CAUTION: Do not bend the fiber-optic cable beyond its minimum bend radius. An arc smaller than a few inches in diameter can damage the cable and cause problems that are difficult to diagnose.

6. To remove an SFP56-DD, SFP, SFP+, XFP, a QSFP+, or QSFP56-DD transceiver:
 - a. Using your fingers, pull open the ejector lever on the transceiver to unlock the transceiver. Note that QSFP-DD and SFP-DD transceivers don't have ejector levers, they have a pull tab instead which can be used to unlock and remove the transceiver.



CAUTION: Before removing the transceiver, make sure that you open the ejector lever completely until you hear it click. This precaution prevents damage to the transceiver.

- b. Grasp the transceiver ejector lever and gently slide the transceiver approximately 0.5 in. (1.3 cm) straight out of the port.



CAUTION: To prevent ESD damage to the transceiver, do not touch the connector pins at the end of the transceiver.

Figure 122: Remove a QSFP+ Transceiver

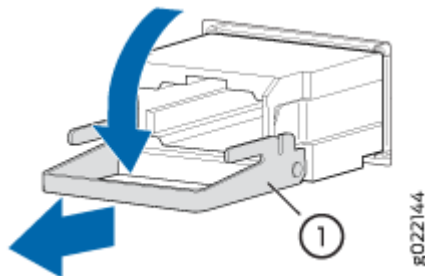

1- Ejector lever

To remove a CFP transceiver:

- a. Using your fingers, loosen the screws on the transceiver.
- b. Grasp the screws on the transceiver and gently slide the transceiver approximately 0.5 in. (1.3 cm) straight out of the port.



CAUTION: To prevent ESD damage to the transceiver, do not touch the connector pins at the end of the transceiver.

7. Using your fingers, grasp the body of the transceiver and pull it straight out of the port.
8. Place the transceiver in the antistatic bag or on the antistatic mat placed on a flat, stable surface.
9. Place the dust cover over the empty port, or install the replacement transceiver.

Install a Transceiver

Before you install a transceiver in a device, ensure that you have taken the necessary precautions for safe handling of lasers (see [Laser and LED Safety Guidelines and Warnings](#)).

Ensure that you have a rubber safety cap available to cover the transceiver.

The transceivers for Juniper Networks devices are hot-removable and hot-insertable field-replaceable units (FRUs). You can remove and replace the transceivers without powering off the device or disrupting the device functions.

NOTE: After you insert a transceiver or after you change the media-type configuration, wait for 6 seconds for the interface to display operational commands.

NOTE: We recommend that you use only optical transceivers and optical connectors purchased from Juniper Networks with your Juniper Networks device.



CAUTION: The Juniper Networks Technical Assistance Center (JTAC) provides complete support for Juniper-supplied optical modules and cables. However, JTAC does not provide support for third-party optical modules and cables that are not qualified or supplied by Juniper Networks. If you face a problem running a Juniper device that uses third-party optical modules or cables, JTAC may help you diagnose host-related issues if the observed issue is not, in the opinion of JTAC, related to the use of the third-party optical modules or cables. Your JTAC engineer will likely request that you check the third-party optical module or cable and, if required, replace it with an equivalent Juniper-qualified component.

Use of third-party optical modules with high-power consumption (for example, coherent ZR or ZR+) can potentially cause thermal damage to or reduce the lifespan of the host equipment. Any damage to the host equipment due to the use of third-party optical modules or cables is the users' responsibility. Juniper Networks will accept no liability for any damage caused due to such use.

Figure 123 on page 188 shows how to install a QSFP+ transceiver. The procedure is the same for all types of transceivers except the QSFP28 and CFP transceivers.

To install a transceiver:



CAUTION: To prevent electrostatic discharge (ESD) damage to the transceiver, do not touch the connector pins at the end of the transceiver.

1. Wrap and fasten one end of the ESD wrist strap around your bare wrist, and connect the other end of the strap to the ESD point on the switch.
2. Remove the transceiver from its bag.
3. Check to see whether the transceiver is covered with a rubber safety cap. If it is not, cover the transceiver with a rubber safety cap.



LASER WARNING: Do not leave a fiber-optic transceiver uncovered except when inserting or removing a cable. The rubber safety cap keeps the port clean and protects your eyes from accidental exposure to laser light.

4. If the port in which you want to install the transceiver is covered with a dust cover, remove the dust cover and save it in case you need to cover the port later. If you are hot-swapping a transceiver, wait for at least 10 seconds after removing the transceiver from the port before installing a new transceiver.
5. Using both hands, carefully place the transceiver in the empty port. The connectors must face the chassis.



CAUTION: Before you slide the transceiver into the port, ensure that the transceiver is aligned correctly. Misalignment might cause the pins to bend, making the transceiver unusable.

6. Slide the transceiver in gently until it is fully seated. If you are installing a CFP transceiver, use your fingers to tighten the captive screws on the transceiver.
7. Remove the rubber safety cap from the transceiver and the end of the cable, and insert the cable into the transceiver.



LASER WARNING: Do not look directly into a fiber-optic transceiver or into the ends of fiber-optic cables. Fiber-optic transceivers and fiber-optic cable connected to a transceiver emit laser light that can damage your eyes.



CAUTION: Do not leave a fiber-optic transceiver uncovered except when inserting or removing cable. The safety cap keeps the port clean and protects your eyes from accidental exposure to laser light.

8. If there is a cable management system, arrange the cable in the cable management system to prevent the cable from dislodging or developing stress points. Secure the cable so that it does not support its own weight as it hangs toward the floor. Place excess cable out of the way in a neatly coiled loop in the cable management system. Placing fasteners on the loop helps to maintain its shape.

CAUTION: Do not let fiber-optic cable hang free from the connector. Do not allow fastened loops of cable to dangle, which stresses the cable at the fastening point.

CAUTION: Avoid bending fiber-optic cable beyond its minimum bend radius. An arc smaller than a few inches in diameter can damage the cable and cause problems that are difficult to diagnose.

NOTE: When you install SFP-DD transceivers, push it hard until you hear a click sound. Use a long nose plier to pull the SFP-DD transceiver connected on the top and bottom rows of the chassis where the pull tabs face each other.

NOTE: Make sure to use a dust cap to cover ports that are unused.

NOTE: While using Finisar AOC SFP+ optical module with the QFX5130-48C switch, you may need to pull the module upwards to pull out the module smoothly from the cage.

NOTE: "

Figure 123: Install a Transceiver

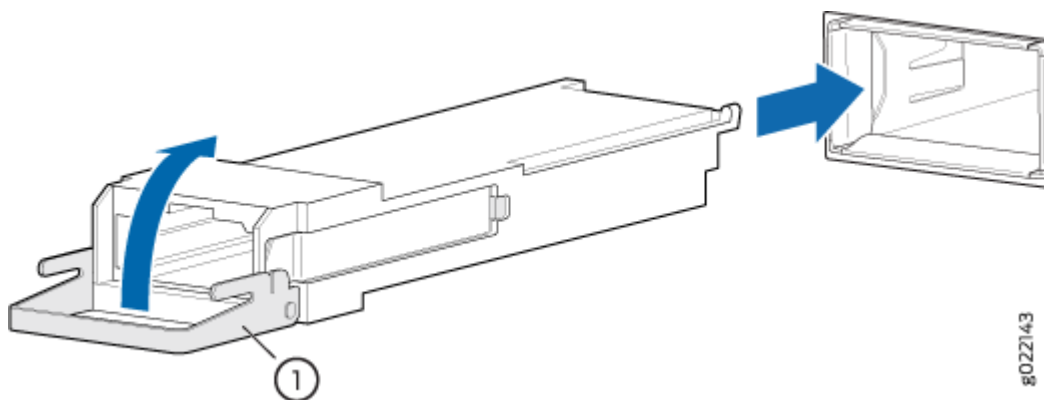

8022143

Maintain Fiber-Optic Cables

IN THIS SECTION

- [Connect a Fiber-Optic Cable | 189](#)
- [Disconnect a Fiber-Optic Cable | 190](#)
- [How to Handle Fiber-Optic Cables | 191](#)

Connect a Fiber-Optic Cable

Before you connect a fiber-optic cable to an optical transceiver installed in a device, ensure that you have taken the necessary precautions for safe handling of lasers (see *Laser and LED Safety Guidelines and Warnings*).

To connect a fiber-optic cable to an optical transceiver installed in a device:



LASER WARNING: Do not look directly into a fiber-optic transceiver or into the ends of fiber-optic cables. Fiber-optic transceivers and fiber-optic cables connected to transceivers emit laser light that can damage your eyes.

1. If the fiber-optic cable connector is covered with a rubber safety cap, remove the cap. Save the cap.
2. Remove the rubber safety cap from the optical transceiver. Save the cap.
3. Insert the cable connector into the optical transceiver (see [Figure 124 on page 190](#)).

Figure 124: Connect a Fiber-Optic Cable to an Optical Transceiver Installed in a Device

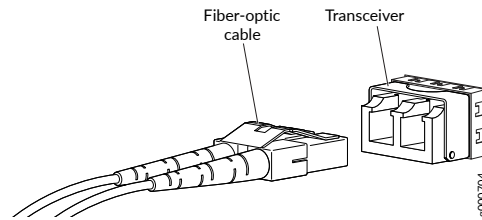

- Secure the cables so that they do not support their own weight. Place excess cable out of the way in a neatly coiled loop. Placing fasteners on a loop helps cables maintain their shape.



CAUTION: Do not bend fiber-optic cables beyond their minimum bend radius. An arc smaller than a few inches in diameter can damage the cables and cause problems that are difficult to diagnose.

Do not let fiber-optic cables hang free from the connector. Do not allow fastened loops of cables to dangle, which stresses the cables at the fastening point.

Disconnect a Fiber-Optic Cable

Before you disconnect a fiber-optic cable from an optical transceiver, ensure that you have taken the necessary precautions for safe handling of lasers. See *Laser and LED Safety Guidelines and Warnings*.

Ensure that you have the following parts and tools available:

- A rubber safety cap to cover the transceiver
- A rubber safety cap to cover the fiber-optic cable connector

Juniper Networks devices have optical transceivers to which you can connect fiber-optic cables.

To disconnect a fiber-optic cable from an optical transceiver installed in the device:

- Disable the port in which the transceiver is installed by issuing the following command:

```
[edit interfaces]
user@device# set interface-name disable
```



LASER WARNING: Do not look directly into a fiber-optic transceiver or into the ends of fiber-optic cables. Fiber-optic transceivers and fiber-optic cables connected to transceivers emit laser light that can damage your eyes.

2. Carefully unplug the fiber-optic cable connector from the transceiver.
3. Cover the transceiver with a rubber safety cap.



LASER WARNING: Do not leave a fiber-optic transceiver uncovered except when inserting or removing a cable. The rubber safety cap keeps the port clean and protects your eyes from accidental exposure to laser light.

4. Cover the fiber-optic cable connector with the rubber safety cap.

How to Handle Fiber-Optic Cables

Fiber-optic cables connect to optical transceivers that are installed in Juniper Networks devices.

Follow these guidelines when handling fiber-optic cables:

- When you unplug a fiber-optic cable from a transceiver, place rubber safety caps over the transceiver and on the end of the cable.
- Anchor fiber-optic cables to prevent stress on the connectors. When attaching a fiber-optic cable to a transceiver, be sure to secure the fiber-optic cable so that it does not support its own weight as it hangs to the floor. Never let a fiber-optic cable hang free from the connector.
- Avoid bending fiber-optic cables beyond their minimum bend radius. Bending fiber-optic cables into arcs smaller than a few inches in diameter can damage the cables and cause problems that are difficult to diagnose.
- Frequent plugging and unplugging of fiber-optic cables in and out of optical instruments can damage the instruments, which are expensive to repair. To prevent damage from overuse, attach a short fiber extension to the optical equipment. The short fiber extension absorbs wear and tear due to frequent plugging and unplugging, which is easier and less expensive to replace than the instruments.
- Keep fiber-optic cable connections clean. Microdeposits of oil and dust in the canal of the transceiver or cable connector can cause loss of light, reduction in signal power, and possibly intermittent problems with the optical connection.

- To clean the transceiver canal, use an appropriate fiber-cleaning device such as RIFOCS Fiber Optic Adaptor Cleaning Wands (part number 946). Follow the instructions in the cleaning kit you use.
- After cleaning the transceiver, make sure that the connector tip of the fiber-optic cable is clean. Use only an approved alcohol-free fiber-optic cable cleaning kit such as the Opptex Cletop-S® Fiber Cleaner. Follow the instructions in the cleaning kit you use.

6

CHAPTER

Troubleshoot Hardware

[Troubleshoot the EX4100-F Components](#) | 194

Troubleshoot the EX4100-F Components

IN THIS SECTION

- [Chassis Component Alarm Conditions on EX4100-F Switches | 194](#)
- [Troubleshoot Temperature Alarms in EX Series Switches | 197](#)

Chassis Component Alarm Conditions on EX4100-F Switches

This topic describes the chassis component alarm conditions on EX4100-F switches.

[Table 46 on page 194](#) lists the alarms that the chassis components can generate on EX4100-F switches. The table lists the severity levels of these alarms and the actions that you can take to respond to them.

Table 46: Chassis Component Alarm Conditions on EX4100-F Switches

Chassis Component	Alarm Condition	Alarm Severity	Remedy
Power supply	A power supply has been removed from the chassis.	Minor	Install a power supply in the empty slot.
	A power supply output has failed.	Major	Check the power supply output connection.
	A power supply has failed.	Major	Replace the failed power supply.
	An unknown power supply is installed.	Major	Install a power supply recommended by Juniper Networks.

Table 46: Chassis Component Alarm Conditions on EX4100-F Switches (Continued)

Chassis Component	Alarm Condition	Alarm Severity	Remedy
	A mix of power supplies with different airflow directions is installed.	Major	Do not mix power supplies with different airflow directions in the same chassis.
	A mix of fan modules and power supplies with different airflow directions is installed.	Major	Do not mix fan modules and power supplies with different airflow directions in the same chassis.
Fan module	A fan module is not installed.	Major	Install the fan module.
	A fan module has failed.	Major	Replace the fan module.
	A mix of fan modules with different airflow directions is installed.	Major	Do not mix fan modules with different airflow directions in the same chassis.
	A mix of fan modules and power supplies with different airflow directions is installed.	Major	Do not mix fan modules and power supplies with different airflow directions in the same chassis.
Temperature	The temperature inside the chassis reached the yellow or amber alarm limit.	Minor	<ul style="list-style-type: none"> • Check the fan. • Open a support case using the Case Manager link at https://www.juniper.net/support/, or call 1-888-314-5822 (toll-free within the United States and Canada) or 1-408-745-9500 (from outside the United States).

Table 46: Chassis Component Alarm Conditions on EX4100-F Switches (Continued)

Chassis Component	Alarm Condition	Alarm Severity	Remedy
	The temperature inside the chassis reached the red alarm limit.	Major	<ul style="list-style-type: none"> • Check the fan. • Open a support case using the Case Manager link at https://www.juniper.net/support/, or call 1-888-314-5822 (toll-free within the United States and Canada) or 1-408-745-9500 (from outside the United States).
Management Ethernet interface	The Management Ethernet link is down.	Major	<ul style="list-style-type: none"> • Check whether a cable is connected to the Management Ethernet interface or whether the cable is defective. Replace the cable, if required. • If you are unable to resolve the problem, open a support case using the Case Manager link at https://www.juniper.net/support/, or call 1-888-314-5822 (toll-free within the United States and Canada) or 1-408-745-9500 (from outside the United States).
Routing Engine	The /var partition usage is high.	Minor	Clean up the system file storage space on the switch. For more information, see Freeing Up System Storage Space .
	The /var partition is full.	Major	Clean up the system file storage space on the switch. For more information, see Freeing Up System Storage Space .
	A rescue configuration is not set.	Minor	Use the request system configuration rescue save command to set the rescue configuration.

Table 46: Chassis Component Alarm Conditions on EX4100-F Switches (Continued)

Chassis Component	Alarm Condition	Alarm Severity	Remedy
	The feature usage requires a license, or the license for the feature usage has expired.	Minor	Install the required license for the feature specified in the alarm. For more information, see Understanding Software Licenses for EX Series Switches .

Troubleshoot Temperature Alarms in EX Series Switches

IN THIS SECTION

- [Problem | 197](#)
- [Cause | 197](#)
- [Solution | 198](#)

Problem

Description

EX Series switches trigger a temperature alarm FPC 0 EX-PFE1 Temp Too Hot when the switch temperature becomes too hot.

Cause

Temperature sensors in the chassis monitor the temperature of the chassis. The switch triggers an alarm if a fan fails or if the temperature of the chassis exceeds permissible levels for some other reason.

Solution

When the switch triggers a temperature alarm such as the FPC 0 EX-PFE1 Temp Too Hot alarm, use the `show chassis environment` and the `show chassis temperature-thresholds` commands to identify the condition that triggered the alarm.



CAUTION: To prevent the switch from overheating, operate it in an area with an ambient temperature within the recommended range. To prevent airflow restriction, allow at least 6 inches (15.2 cm) of clearance around the ventilation openings.

1. Connect to the switch by using Telnet, and issue the `show chassis environment` command. This command displays environmental information about the switch chassis, including the temperature. The command also displays information about the fans, power supplies, and Routing Engines. Following is a sample output on an EX9208 switch. The output is similar on other EX Series switches.

show chassis environment (EX9208 Switch)

```

user@switch> show chassis environment

Class Item                Status      Measurement
Temp PEM 0                OK         40 degrees C / 104 degrees F
    PEM 1                  OK         40 degrees C / 104 degrees F
    PEM 2                  Absent
    PEM 3                  Absent
Routing Engine 0          OK         37 degrees C / 98 degrees F
Routing Engine 0 CPU      OK         35 degrees C / 95 degrees F
Routing Engine 1          Absent
Routing Engine 1 CPU      Absent
CB 0 Intake               OK         36 degrees C / 96 degrees F
CB 0 Exhaust A            OK         34 degrees C / 93 degrees F
CB 0 Exhaust B            OK         40 degrees C / 104 degrees F
CB 0 ACBC                 OK         39 degrees C / 102 degrees F
CB 0 XF A                 OK         46 degrees C / 114 degrees F
CB 0 XF B                 OK         45 degrees C / 113 degrees F
CB 1 Intake               Absent
CB 1 Exhaust A            Absent
CB 1 Exhaust B            Absent
CB 1 ACBC                 Absent
CB 1 XF A                 Absent
CB 1 XF B                 Absent
FPC 3 Intake              OK         48 degrees C / 118 degrees F
FPC 3 Exhaust A           OK         46 degrees C / 114 degrees F

```

FPC 3 Exhaust B	OK	51 degrees C / 123 degrees F
FPC 3 XL TSen	OK	67 degrees C / 152 degrees F
FPC 3 XL Chip	OK	58 degrees C / 136 degrees F
FPC 3 XL_XR0 TSen	OK	67 degrees C / 152 degrees F
FPC 3 XL_XR0 Chip	OK	51 degrees C / 123 degrees F
FPC 3 XL_XR1 TSen	OK	67 degrees C / 152 degrees F
FPC 3 XL_XR1 Chip	OK	63 degrees C / 145 degrees F
FPC 3 XQ TSen	OK	67 degrees C / 152 degrees F
FPC 3 XQ Chip	OK	63 degrees C / 145 degrees F
FPC 3 XQ_XR0 TSen	OK	67 degrees C / 152 degrees F
FPC 3 XQ_XR0 Chip	OK	68 degrees C / 154 degrees F
FPC 3 XM TSen	OK	67 degrees C / 152 degrees F
FPC 3 XM Chip	OK	76 degrees C / 168 degrees F
FPC 3 XF TSen	OK	67 degrees C / 152 degrees F
FPC 3 XF Chip	OK	75 degrees C / 167 degrees F
FPC 3 PLX PCIe Switch TSe	OK	51 degrees C / 123 degrees F
FPC 3 PLX PCIe Switch Chi	OK	54 degrees C / 129 degrees F
FPC 3 Aloha FPGA 0 TSen	OK	51 degrees C / 123 degrees F
FPC 3 Aloha FPGA 0 Chip	OK	70 degrees C / 158 degrees F
FPC 3 Aloha FPGA 1 TSen	OK	51 degrees C / 123 degrees F
FPC 3 Aloha FPGA 1 Chip	OK	75 degrees C / 167 degrees F
FPC 5 Intake	Testing	
FPC 5 Exhaust A	Testing	
FPC 5 Exhaust B	Testing	
Fans Top Rear Fan	OK	Spinning at intermediate-speed
Bottom Rear Fan	OK	Spinning at intermediate-speed
Top Middle Fan	OK	Spinning at intermediate-speed
Bottom Middle Fan	OK	Spinning at intermediate-speed
Top Front Fan	OK	Spinning at intermediate-speed
Bottom Front Fan	OK	Spinning at intermediate-speed

[Table 47 on page 200](#) lists the output fields for the show chassis environment command. The table lists output fields in the approximate order in which they appear.

Table 47: show chassis environment Output Fields

Field Name	Field Description
Class	Information about the category or class of chassis component: <ul style="list-style-type: none"> Temp: Temperature of air flowing through the chassis in degrees Celsius (°C) and degrees Fahrenheit (°F) Fans: Information about the status of fans and blowers
Item	Information about the chassis components: <ul style="list-style-type: none"> Flexible PIC Concentrators (FPCs)—that is, the line cards Control Boards (CBs) Routing Engines Power entry modules (PEMs)—that is, the power supplies
Status	Status of the specified chassis component. For example, if Class is Fans, the fan status can be: <ul style="list-style-type: none"> OK: The fans are operational. Testing: The fans are being tested during initial power-on. Failed: The fans have failed or the fans are not spinning. Absent: The fan tray is not installed.
Measurement	Depends on the Class. For example, if Class is Temp, indicates the temperature in degrees Celsius (°C) and degrees Fahrenheit (°F). If the Class is Fans, indicates actual fan RPM.

- Issue the command `show chassis temperature-thresholds` . This command displays the chassis temperature threshold settings. The following is a sample output on an EX9208 switch. The output is similar on other EX Series switches.

`show chassis temperature-thresholds (EX9208 Switch)`

```
user@ host> show chassis temperature-thresholds
Fan speed      Yellow alarm   Red alarm     Fire Shutdown
```

Item	(degrees C)		(degrees C)		(degrees C)		(degrees C)
	Normal	High	Normal	Bad fan	Normal	Bad fan	Normal
Chassis default	48	54	65	55	80	65	100
Routing Engine 0	70	80	95	95	110	110	112
FPC 3	55	60	75	65	105	80	110
FPC 5	55	60	75	65	90	80	95

Table 48 on page 201 lists the output fields for the `show chassis temperature-thresholds` command. The table lists output fields in the approximate order in which they appear.

Table 48: show chassis temperature-thresholds Output Fields

Field Name	Field Description
Item	Chassis component. You can configure the threshold information for components such as the chassis, the Routing Engines, and FPC for each slot in each FRU to display in the output. By default, information is displayed only for the chassis and the Routing Engines.
Fan speed	<p>Temperature thresholds, in degrees Celsius, for the fans to operate at normal and at high speed.</p> <ul style="list-style-type: none"> • Normal—The temperature threshold at which the fans operate at normal speed and when all the fans are present and functioning normally. • High—The temperature threshold at which the fans operate at high speed or when a fan has failed or is missing. <p>NOTE: An alarm is triggered when the temperature exceeds the threshold settings for a yellow, amber, or red alarm.</p>
Yellow or amber alarm	<p>Temperature threshold, in degrees Celsius, that triggers a yellow or amber alarm.</p> <ul style="list-style-type: none"> • Normal—The temperature threshold that must be exceeded on the device to trigger a yellow or amber alarm when the fans are running at full speed. • Bad fan—The temperature threshold that must be exceeded on the device to trigger a yellow or amber alarm when one or more fans have failed or are missing.

Table 48: show chassis temperature-thresholds Output Fields (Continued)

Field Name	Field Description
Red alarm	<p>Temperature threshold, in degrees Celsius, that triggers a red alarm.</p> <ul style="list-style-type: none"> • Normal—The temperature threshold that must be exceeded on the device to trigger a red alarm when the fans are running at full speed. • Bad fan—The temperature threshold that must be exceeded on the device to trigger a red alarm when one or more fans have failed or are missing.
Fire shutdown	<p>Temperature threshold, in degrees Celsius, at which the switch shuts down in case of fire.</p>

When a temperature alarm is triggered, you can identify the condition that triggered it by running the `show chassis environment` command to display the chassis temperature values for each component and comparing those with the temperature threshold values. You can display the temperature threshold values by running the `show chassis temperature-thresholds` command.

For example, for FPC 3:

- If the temperature of FPC 3 exceeds 55° C, the output indicates that the fans are operating at a high speed (no alarm is triggered).
- If the temperature of FPC 3 exceeds 65° C, a yellow alarm is triggered to indicate that one or more fans have failed.
- If the temperature of FPC 3 exceeds 75° C, a yellow alarm is triggered to indicate that the temperature threshold limit is exceeded.
- If the temperature of FPC 3 exceeds 80° C, a red alarm is triggered to indicate that one or more fans have failed.
- If the temperature of FPC 3 exceeds 105° C, a red alarm is triggered to indicate that the temperature threshold limit is exceeded.
- If the temperature of FPC 3 exceeds 110° C, the switch is powered off.

[Table 49 on page 203](#) lists the possible causes for the switch to generate a temperature alarm. It also lists the respective remedies.

Table 49: Causes and Remedies for Temperature Alarms

Cause	Remedy
Ambient temperature is above threshold temperature.	Ensure that the ambient temperature is within the threshold temperature limit. See <i>Environmental Requirements and Specifications for EX Series Switches</i> .
Fan module or fan tray has failed.	Perform the following steps: <ol style="list-style-type: none">1. Check the fan.2. Replace the faulty fan module or fan tray.3. If the above two checks show no problems, open a support case using the Case Manager link at https://www.juniper.net/support/ or call 1-888-314-5822 (toll-free within the United States and Canada) or 1-408-745-9500 (from outside the United States).
Restricted airflow through the switch due to insufficient clearance around the installed switch.	Ensure that there is sufficient clearance around the installed switch.

7

CHAPTER

Contact Customer Support and Return the Chassis or Components

[Contacting Customer Support | 205](#)

[Return an EX4100-F Chassis | 206](#)

Contacting Customer Support

IN THIS SECTION

- [Global Support | 205](#)
- [Support for Third-Party Transceivers | 206](#)

You can contact the Juniper Networks Technical Assistance Center (JTAC) 24 hours a day, seven days a week.

Global Support

Chat	<p>Use the Ask me icon at the bottom right of the Support page to request support 24 hours a day, seven days a week.</p> <p>Don't see the Chat icon? Read this.</p>
Web	<p>Juniper Support Portal</p> <p>Juniper Government Support Portal</p>
Phone	<p>US & Canada (Toll-free): 1-888-314-5822</p> <p>Outside the US or Canada, use the relevant country number listed on the regional tabs listed on the Contact Support page.</p> <p>Federal Government Support: 1-833-900-1454.</p>

NOTE: We do not support opening new cases via email. Please use one of the above options to contact Global Support.

Support for Third-Party Transceivers

The Juniper Networks Technical Assistance Center (JTAC) provides complete support for Juniper-supplied optical modules and cables. However, JTAC does not provide support for third-party optical modules and cables that are not qualified or supplied by Juniper Networks. If you face a problem running a Juniper device that uses third-party optical modules or cables, JTAC may help you diagnose host-related issues if the observed issue is not, in the opinion of JTAC, related to the use of the third-party optical modules or cables. Your JTAC engineer will likely request that you check the third-party optical module or cable and, if required, replace it with an equivalent Juniper-qualified component.

Use of third-party optical modules with high-power consumption (for example, coherent ZR or ZR+) can potentially cause thermal damage to or reduce the lifespan of the host equipment. Any damage to the host equipment due to the use of third-party optical modules or cables is the users' responsibility. Juniper Networks will accept no liability for any damage caused due to such use.

Return an EX4100-F Chassis

IN THIS SECTION

- [How to Return an EX4100-F Switch for Repair or Replacement | 206](#)
- [Locate the Serial Number on an EX4100-F Switch | 207](#)
- [Contact Customer Support to Obtain a Return Material Authorization | 214](#)
- [Pack an EX4100-F Switch for Shipping | 215](#)

How to Return an EX4100-F Switch for Repair or Replacement

If you need to return a switch or hardware component to Juniper Networks for repair or replacement, follow this procedure:

1. Determine the serial number of the chassis if you need to return the switch. If you need to return one or more components, determine the serial number for each component. For instructions, see ["Locate the Serial Number on an EX4100-F Switch" on page 207](#).

2. Obtain a Return Material Authorization (RMA) number from the Juniper Networks Technical Assistance Center (JTAC) as described in [Contact Customer Support to Obtain Return Material Authorization](#).

NOTE: Obtain an RMA number before you return any component to Juniper Networks. Juniper Networks reserves the right to refuse shipments that lack an RMA. Refused shipments are returned to the customer through collect freight, meaning that you pay for the returned delivery.

3. Pack the switch or component for shipping as described in "[Pack an EX4100-F Switch for Shipping](#)" on page 215.

For more information about return and repair policies, see the customer support page at <https://www.juniper.net/support/guidelines.html>.

Locate the Serial Number on an EX4100-F Switch

IN THIS SECTION

- [List the Switch and Components Details with the CLI | 208](#)
- [Locate the Chassis Serial Number ID Label on an EX4100-F Switch | 213](#)

If you are returning a switch or hardware component to Juniper Networks for repair or replacement, you must locate the serial number of the switch or component. You must provide the serial number to the Juniper Networks Technical Assistance Center (JTAC) to obtain a Return Material Authorization (RMA) number.

If the switch is operational and you can access the CLI, you can list serial numbers for the switch and for some components with a CLI command.

You can also find the serial number ID label on the physical switch or component. This option is helpful in either of these instances:

- You do not have access to the CLI.
- The serial number does not appear in the command output.

NOTE: If you want to find the serial number on the physical switch component, you will need to remove the component from the switch chassis.

List the Switch and Components Details with the CLI

To list the switch and switch components and their serial numbers, enter the CLI command `show chassis hardware extensive`.

The following output lists the switch components and serial numbers for an EX4100 switch.

```
show chassis hardware extensive
Hardware inventory:
Item          Version  Part number  Serial number  Description
Chassis
Jedec Code:   0x0000          EEPROM Version:  0x00
              S/N:                FA1422AN0045
Assembly ID:  0xf000          Assembly Version: 00.00
Date:         00-00-0000      Assembly Flags:  0x00
Board Information Record:
Address 0x00: 00 00 00 00 00 00 00 00 00 00 00 00 00 00 00 00
I2C Hex Data:
Address 0x00: 00 00 00 00 f0 00 00 00 00 00 00 00 00 00 00 00
Address 0x10: 00 00 00 00 00 00 00 00 00 00 00 00 00 00 00 00
Address 0x20: 46 41 31 34 32 32 41 4e 30 30 34 35 00 00 00 00
Address 0x30: 00 00 00 00 00 00 00 00 00 00 00 00 00 00 00 00
Address 0x40: 00 00 00 00 00 00 00 00 00 00 00 00 00 00 00 00
Address 0x50: 00 00 00 00 00 00 00 00 00 00 00 00 00 00 00 00
Address 0x60: 00 00 00 00 00 00 00 00 00 00 00 00 00 00 00 00
Address 0x70: 00 00 00 00 00 00 00 00 00 00 00 00 00 00 00 00
Pseudo CB 0
Routing Engine 0          BUILTIN      BUILTIN      RE-EX4100-48P
Jedec Code:   0x7fb0          EEPROM Version:  0x02
P/N:         BUILTIN          S/N:           BUILTIN
Assembly ID:  0xf010          Assembly Version: 01.04
Date:         04-13-2022      Assembly Flags:  0x00
              CLEI Code:        DUMMY_CLEI
              FRU Model Number:  EX4100-48P
Board Information Record:
Address 0x00: ad 01 00 80 04 69 8f 0f 2a c8 ff ff ff ff ff ff
I2C Hex Data:
```

```

Address 0x00: 7f b0 02 fe f0 10 01 04 00 00 00 00 00 00 00
Address 0x10: 00 00 00 00 42 55 49 4c 54 49 4e 00 00 00 00
Address 0x20: 42 55 49 4c 54 49 4e 00 00 00 00 00 0d 04 07
Address 0x30: e6 ff ff ff ad 01 00 80 04 69 8f 0f 2a c8 ff ff
Address 0x40: ff ff ff ff 01 44 55 4d 4d 59 5f 43 4c 45 49 45
Address 0x50: 58 34 31 30 30 2d 34 38 50 00 00 00 00 00 00
Address 0x60: 00 00 00 00 00 00 31 00 00 ff ff ff ff ff ff
Address 0x70: ff ff ff 7b 46 41 31 34 32 32 41 4e 30 30 34 35
flash/s      8 MB mx25l164                               SPI Flash
usb0 (addr 0.1) XHCI root HUB 0      Marvell      uhub0
usb1 (addr 0.1) USB2.0 Hub 1544      vendor 0x05e3  uhub1
usb2 (addr 0.2) USBFlashDrive 4096   USB          umass0
usb3 (addr 0.3) USB Flash Module 72   Swissbit     umass1
FPC 0          REV 04   650-134056   FA1422AN0045   EX4100-48P
Jedec Code:   0x7fb0           EEPROM Version: 0x02
P/N:          650-134056       S/N:           FA1422AN0045
Assembly ID:  0x05c2           Assembly Version: 01.04
Date:         04-13-2022       Assembly Flags: 0x00
Version:      REV 04           CLEI Code:     DUMMY_CLEI
ID: EX4100-48P                 FRU Model Number: EX4100-48P
Board Information Record:
Address 0x00: ad 01 00 80 04 69 8f 0f 2a c8 ff ff ff ff ff
I2C Hex Data:
Address 0x00: 7f b0 02 fe 05 c2 01 04 52 45 56 20 30 34 00 00
Address 0x10: 00 00 00 00 36 35 30 2d 31 33 34 30 35 36 00 00
Address 0x20: 46 41 31 34 32 32 41 4e 30 30 34 35 00 0d 04 07
Address 0x30: e6 ff ff ff ad 01 00 80 04 69 8f 0f 2a c8 ff ff
Address 0x40: ff ff ff ff 01 44 55 4d 4d 59 5f 43 4c 45 49 45
Address 0x50: 58 34 31 30 30 2d 34 38 50 00 00 00 00 00 00
Address 0x60: 00 00 00 00 00 00 31 00 00 ff ff ff ff ff ff
Address 0x70: ff ff ff 7b 46 41 31 34 32 32 41 4e 30 30 34 35
CPU          BUILTIN      BUILTIN      FPC CPU
Jedec Code:  0x7fb0           EEPROM Version: 0x02
P/N:         BUILTIN          S/N:          BUILTIN
Assembly ID: 0xf020           Assembly Version: 01.04
Date:        04-13-2022       Assembly Flags: 0x00
Board Information Record:
Address 0x00: ad 01 00 80 04 69 8f 0f 2a c8 ff ff ff ff ff
I2C Hex Data:
Address 0x00: 7f b0 02 fe f0 20 01 04 00 45 56 20 30 34 00 00
Address 0x10: 00 00 00 00 42 55 49 4c 54 49 4e 00 35 36 00 00
Address 0x20: 42 55 49 4c 54 49 4e 00 30 30 34 35 00 0d 04 07
Address 0x30: e6 ff ff ff ad 01 00 80 04 69 8f 0f 2a c8 ff ff

```

```

Address 0x40: ff ff ff ff 00 44 55 4d 4d 59 5f 43 4c 45 49 45
Address 0x50: 58 34 31 30 30 2d 34 38 50 00 00 00 00 00 00
Address 0x60: 00 00 00 00 00 00 31 00 00 ff ff ff ff ff ff
Address 0x70: ff ff ff 7b 46 41 31 34 32 32 41 4e 30 30 34 35
PIC 0          REV 04  BUILTIN      BUILTIN          48x10M/100M/1G Base-T
Jedec Code:    0x7fb0          EEPROM Version:  0x02
P/N:           BUILTIN        S/N:            BUILTIN
Assembly ID:   0xf050          Assembly Version: 01.04
Date:          04-13-2022      Assembly Flags:  0x00
Version:       REV 04          CLEI Code:      DUMMY_CLEI
                                   FRU Model Number:  EX4100-48P

```

Board Information Record:

```
Address 0x00: ad 01 00 80 04 69 8f 0f 2a c8 ff ff ff ff ff
```

I2C Hex Data:

```

Address 0x00: 7f b0 02 fe f0 50 01 04 52 45 56 20 30 34 00 00
Address 0x10: 00 00 00 00 42 55 49 4c 54 49 4e 00 35 36 00 00
Address 0x20: 42 55 49 4c 54 49 4e 00 30 30 34 35 00 0d 04 07
Address 0x30: e6 ff ff ff ad 01 00 80 04 69 8f 0f 2a c8 ff ff
Address 0x40: ff ff ff ff 01 44 55 4d 4d 59 5f 43 4c 45 49 45
Address 0x50: 58 34 31 30 30 2d 34 38 50 00 00 00 00 00 00
Address 0x60: 00 00 00 00 00 00 31 00 00 ff ff ff ff ff ff
Address 0x70: ff ff ff 7b 55 55 55 55 55 55 55 55 55 55 55

```

```

PIC 1          REV 04  650-134056  FA1422AN0045      4x1G/10G/25G SFP/SFP+/SFP28
Jedec Code:    0x7fb0          EEPROM Version:  0x02
P/N:           650-134056      S/N:            FA1422AN0045
Assembly ID:   0xf051          Assembly Version: 01.04
Date:          04-13-2022      Assembly Flags:  0x00
Version:       REV 04          CLEI Code:      DUMMY_CLEI
                                   FRU Model Number:  EX4100-48P

```

Board Information Record:

```
Address 0x00: ad 01 00 80 04 69 8f 0f 2a c8 ff ff ff ff ff
```

I2C Hex Data:

```

Address 0x00: 7f b0 02 fe f0 51 01 04 52 45 56 20 30 34 00 00
Address 0x10: 00 00 00 00 36 35 30 2d 31 33 34 30 35 36 00 00
Address 0x20: 46 41 31 34 32 32 41 4e 30 30 34 35 00 0d 04 07
Address 0x30: e6 ff ff ff ad 01 00 80 04 69 8f 0f 2a c8 ff ff
Address 0x40: ff ff ff ff 01 44 55 4d 4d 59 5f 43 4c 45 49 45
Address 0x50: 58 34 31 30 30 2d 34 38 50 00 00 00 00 00 00
Address 0x60: 00 00 00 00 00 00 31 00 00 ff ff ff ff ff ff
Address 0x70: ff ff ff 7b 55 55 55 55 55 55 55 55 55 55 55

```

```

PIC 2          REV 04  650-134056  FA1422AN0045      4x1G/10G SFP/SFP+
Jedec Code:    0x7fb0          EEPROM Version:  0x02
P/N:           650-134056      S/N:            FA1422AN0045

```

Assembly ID: 0xf052 Assembly Version: 01.04
 Date: 04-13-2022 Assembly Flags: 0x00
 Version: REV 04 CLEI Code: DUMMY_CLEI
 FRU Model Number: EX4100-48P

Board Information Record:

Address 0x00: ad 01 00 80 04 69 8f 0f 2a c8 ff ff ff ff ff ff

I2C Hex Data:

Address 0x00: 7f b0 02 fe f0 52 01 04 52 45 56 20 30 34 00 00
 Address 0x10: 00 00 00 00 36 35 30 2d 31 33 34 30 35 36 00 00
 Address 0x20: 46 41 31 34 32 32 41 4e 30 30 34 35 00 0d 04 07
 Address 0x30: e6 ff ff ff ad 01 00 80 04 69 8f 0f 2a c8 ff ff
 Address 0x40: ff ff ff ff 01 44 55 4d 4d 59 5f 43 4c 45 49 45
 Address 0x50: 58 34 31 30 30 2d 34 38 50 00 00 00 00 00 00
 Address 0x60: 00 00 00 00 00 00 31 00 00 ff ff ff ff ff ff ff
 Address 0x70: ff ff ff 7b 55 55 55 55 55 55 55 55 55 55 55

Power Supply 0 REV 05 640-060601 1EDSB490H14 JPSU-920W-AC-AFO

Jedec Code: 0x7fb0 EEPROM Version: 0x02
 P/N: 640-060601 S/N: 1EDSB490H14
 Assembly ID: 0x0493 Assembly Version: 05.05
 Date: 11-29-2021 Assembly Flags: 0x00
 Version: REV 05 CLEI Code: CMUPAELBAA
 ID: JPSU-920W-AC-AFO FRU Model Number: JPSU-920-AC-AFO

Board Information Record:

Address 0x00: b0 01 ff ff ff ff ff ff ff ff ff ff 09 20 00 ff

I2C Hex Data:

Address 0x00: 7f b0 02 ff 04 93 05 05 52 45 56 20 30 35 00 00
 Address 0x10: 00 00 00 00 36 34 30 2d 30 36 30 36 30 31 00 00
 Address 0x20: 31 45 44 53 42 34 39 30 48 31 34 00 00 1d 0b 07
 Address 0x30: e5 ff ff ff b0 01 ff ff ff ff ff ff ff ff ff
 Address 0x40: 09 20 00 ff 01 43 4d 55 50 41 45 4c 42 41 41 4a
 Address 0x50: 50 53 55 2d 39 32 30 2d 41 43 2d 41 46 4f 00 00
 Address 0x60: 00 00 00 00 00 00 41 30 30 ff ff ff ff ff ff ff
 Address 0x70: ff ff ff 21 ff ff ff ff ff ff ff ff ff ff ff

Power Supply 1 REV 05 640-060601 1EDSB490GTM JPSU-920W-AC-AFO

Jedec Code: 0x7fb0 EEPROM Version: 0x02
 P/N: 640-060601 S/N: 1EDSB490GTM
 Assembly ID: 0x0493 Assembly Version: 05.05
 Date: 11-29-2021 Assembly Flags: 0x00
 Version: REV 05 CLEI Code: CMUPAELBAA
 ID: JPSU-920W-AC-AFO FRU Model Number: JPSU-920-AC-AFO

Board Information Record:

Address 0x00: b0 01 ff ff ff ff ff ff ff ff ff ff 09 20 00 ff

I2C Hex Data:

```

Address 0x00: 7f b0 02 ff 04 93 05 05 52 45 56 20 30 35 00 00
Address 0x10: 00 00 00 00 36 34 30 2d 30 36 30 36 30 31 00 00
Address 0x20: 31 45 44 53 42 34 39 30 47 54 4d 00 00 1d 0b 07
Address 0x30: e5 ff ff ff b0 01 ff ff ff ff ff ff ff ff ff
Address 0x40: 09 20 00 ff 01 43 4d 55 50 41 45 4c 42 41 41 4a
Address 0x50: 50 53 55 2d 39 32 30 2d 41 43 2d 41 46 4f 00 00
Address 0x60: 00 00 00 00 00 00 41 30 30 ff ff ff ff ff ff ff
Address 0x70: ff ff ff 21 ff ff ff ff ff ff ff ff ff ff ff

Fan Tray 0                                     Fan Module, Airflow Out (AFO)
Jedec Code: 0x7fb0                           EEPROM Version: 0x00
Assembly ID: 0xf040                           Assembly Version: 00.00
Date: 00-00-0000                             Assembly Flags: 0x00
Board Information Record:
Address 0x00: 00 00 00 00 00 00 00 00 00 00 00 00 00 00 00 00
I2C Hex Data:
Address 0x00: 7f b0 00 00 f0 40 00 00 00 00 00 00 00 00 00 00
Address 0x10: 00 00 00 00 00 00 00 00 00 00 00 00 00 00 00 00
Address 0x20: 00 00 00 00 00 00 00 00 00 00 00 00 00 00 00 00
Address 0x30: 00 00 00 00 00 00 00 00 00 00 00 00 00 00 00 00
Address 0x40: 00 00 00 00 00 00 00 00 00 00 00 00 00 00 00 00
Address 0x50: 00 00 00 00 00 00 00 00 00 00 00 00 00 00 00 00
Address 0x60: 00 00 00 00 00 00 00 00 00 00 00 00 00 00 00 00
Address 0x70: 00 00 00 00 00 00 00 00 00 00 00 00 00 00 00 00

Fan Tray 1                                     Fan Module, Airflow Out (AFO)
Jedec Code: 0x7fb0                           EEPROM Version: 0x00
Assembly ID: 0xf040                           Assembly Version: 00.00
Date: 00-00-0000                             Assembly Flags: 0x00
Board Information Record:
Address 0x00: 00 00 00 00 00 00 00 00 00 00 00 00 00 00 00 00
I2C Hex Data:
Address 0x00: 7f b0 00 00 f0 40 00 00 00 00 00 00 00 00 00 00
Address 0x10: 00 00 00 00 00 00 00 00 00 00 00 00 00 00 00 00
Address 0x20: 00 00 00 00 00 00 00 00 00 00 00 00 00 00 00 00
Address 0x30: 00 00 00 00 00 00 00 00 00 00 00 00 00 00 00 00
Address 0x40: 00 00 00 00 00 00 00 00 00 00 00 00 00 00 00 00
Address 0x50: 00 00 00 00 00 00 00 00 00 00 00 00 00 00 00 00
Address 0x60: 00 00 00 00 00 00 00 00 00 00 00 00 00 00 00 00
Address 0x70: 00 00 00 00 00 00 00 00 00 00 00 00 00 00 00 00

```

For information about the `show chassis hardware` command, see [show chassis hardware](#).

Locate the Chassis Serial Number ID Label on an EX4100-F Switch

As indicated by the following figures, locate the serial number ID label of an EX4100-F chassis.

Figure 125: Location of the Serial Number ID Label on the EX4100-F-24P Switch

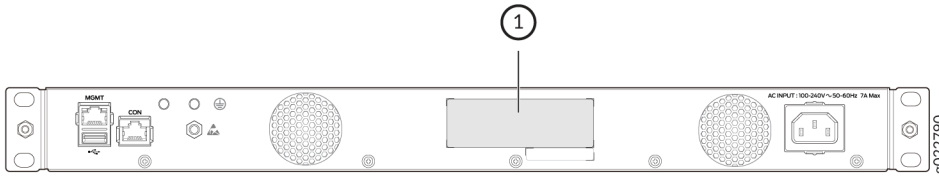

1- Serial Number ID Label

Figure 126: Location of the Serial Number ID Label on the EX4100-F-24T and EX4100-F-48T Switches



1- Serial Number ID Label

Figure 127: Location of the Serial Number ID Label on the EX4100-F-48P Switches

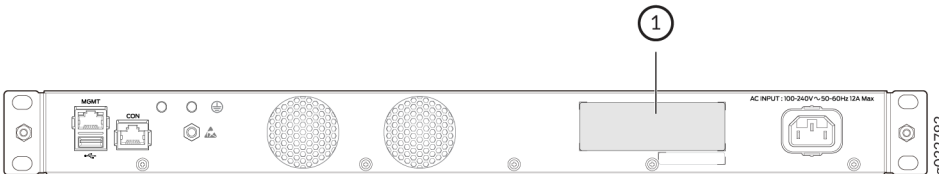

1- Serial Number ID Label

Figure 128: Location of the Serial Number ID Label on the EX4100-F-12P and EX4100-F-12T Switches

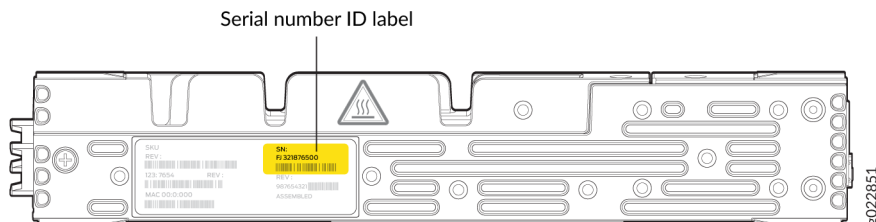

Contact Customer Support to Obtain a Return Material Authorization

If you need to return a device or hardware component to Juniper Networks for repair or replacement, obtain a Return Material Authorization (RMA) number from Juniper Networks Technical Assistance Center (JTAC). You must obtain an RMA number before you attempt to return the component.

After locating the serial number of the device or hardware component you want to return, open a service request with the Juniper Networks Technical Assistance Center (JTAC) on the Web or by telephone.

Before you request an RMA number from JTAC, be prepared to provide the following information:

- Your existing service request number, if you have one
- Serial number of the component
- Your name, organization name, telephone number, fax number, and shipping address
- Details of the failure or problem
- Type of activity being performed on the device when the problem occurred
- Configuration data displayed by one or more `show` commands

You can contact JTAC 24 hours a day, seven days a week on the Web or by telephone:

- Service Request Manager: <https://support.juniper.net/support>
- Telephone: +1-888-314-JTAC (+1-888-314-5822), toll free in U.S., Canada, and Mexico

NOTE: For international or direct-dial options in countries without toll free numbers, see <https://support.juniper.net/support>.

If you are contacting JTAC by telephone, enter your 12-digit service request number followed by the pound (#) key for an existing case, or press the star (*) key to be routed to the next available support engineer.

The support representative validates your request and issues an RMA number for return of the component.

Pack an EX4100-F Switch for Shipping

IN THIS SECTION

- [Pack an EX4100-F Switch for Shipping | 215](#)

If you are returning the switch or component to Juniper Networks for repair or replacement, pack the item as described in this topic.

Before you pack the switch or component, ensure that you have:

- Followed all the steps listed in [Contact Customer Support to Obtain a Return Material Authorization](#).
- Retrieved the original shipping carton and packing materials. Contact your JTAC representative if you do not have these materials, to learn about approved packing materials (see [Contact Customer Support to Obtain a Return Material Authorization](#)).
- Ensure that you understand how to prevent electrostatic discharge (ESD) damage (see ["Prevention of Electrostatic Discharge Damage" on page 245](#)).

Pack an EX4100-F Switch for Shipping

Before you pack the switch:

1. On the console or other management device connected to the switch, enter the CLI operational mode and issue the following command to shut down the switch software:

```
user@switch> request system halt
```

Wait until a message appears on the console confirming that the operating system has halted.

2. Disconnect power from the switch.
3. Remove the cables that connect the switch to external devices.
4. Remove all optical transceivers installed in the switch (see [Remove a Transceiver](#)).

If you need to transport the switch to another location or return the switch to Juniper Networks, you need to pack the switch securely in its original packaging to prevent damage during shipping.

Ensure that you have the following parts and tools:

- Number 2 Phillips (+) screwdriver—not provided
- The original switch packing material (cardboard box, accessory box and its contents, and foam padding)
- An ESD grounding strap—not provided
- Antistatic bag—not provided



CAUTION: Do not pack the switch in anything except its original container, or the switch might be damaged in transit.

To pack the switch:

1. If the switch is installed in a rack or cabinet, have one person support the weight of the switch while another person unscrews and removes the mounting screws.
2. Remove the switch from the rack or cabinet and place the switch on a flat, stable surface.
3. Use the screwdriver to remove the rack mounting brackets from the switch chassis.
4. Place the switch in an antistatic bag.
5. Place the bottom portion of the packaging foam in the shipping carton.
6. Place the switch inside the cavity in the bottom packaging foam.
7. Place the top portion of the packaging foam on top of the switch.
8. If you are returning accessories or field-replaceable units (FRUs) with the switch, pack them as instructed in .
9. Place the accessory box by the rear end of the chassis in the shipping carton.

10. Close the top of the cardboard shipping box and seal it with packing tape.
11. Write the RMA number on the exterior of the box to ensure proper tracking.



CHAPTER

Safety and Compliance Information

Safety Information for EX4100-F | 220

General Safety Guidelines and Warnings | 220

Definitions of Safety Warning Levels | 221

Qualified Personnel Warning | 223

Warning Statement for Norway and Sweden | 224

Fire Safety Requirements | 224

Installation Instructions Warning | 225

Chassis and Component Lifting Guidelines | 226

Restricted Access Warning | 227

Ramp Warning | 228

Rack-Mounting and Cabinet-Mounting Warnings | 229

Grounded Equipment Warning | 233

Radiation from Open Port Apertures Warning | 233

Laser and LED Safety Guidelines and Warnings | 234

Maintenance and Operational Safety Guidelines and Warnings | 237

General Electrical Safety Guidelines and Warnings | 243

Action to Take After an Electrical Accident | 245

Prevention of Electrostatic Discharge Damage | 245

AC Power Electrical Safety Guidelines | 247

AC Power Disconnection Warning | 248

[DC Power Electrical Safety Guidelines | 249](#)

[DC Power Disconnection Warning | 250](#)

[DC Power Grounding Requirements and Warning | 251](#)

[DC Power Wiring Sequence Warning | 252](#)

[DC Power Wiring Terminations Warning | 254](#)

[Multiple Power Supplies Disconnection Warning | 255](#)

[TN Power Warning | 256](#)

[Agency Approvals for EX Series Switches | 257](#)

[Compliance Statements for EMC Requirements for EX Series Switches | 258](#)

[Compliance Statements for Acoustic Noise for EX Series Switches | 262](#)

[Statements of Volatility for Juniper Network Devices | 262](#)

Safety Information for EX4100-F

The [Juniper Networks Safety Guide](#) provides general safety information and guidelines for all Juniper Networks products. Follow the guidelines provided in the guide to reduce the likelihood of personal injury, equipment damage, and damage to surrounding areas.

Along with the information provided in the Juniper Networks Safety Guide, you must read and understand the *EX4100-F* specific safety information provided in this hardware guide.

General Safety Guidelines and Warnings

The following guidelines help ensure your safety and protect the device from damage. The list of guidelines might not address all potentially hazardous situations in your working environment, so be alert and exercise good judgment at all times.

- Perform only the procedures explicitly described in the hardware documentation for this device. Make sure that only authorized service personnel perform other system services.
- Keep the area around the device clear and free from dust before, during, and after installation.
- Keep tools away from areas where people could trip over them while walking.
- Do not wear loose clothing or jewelry, such as rings, bracelets, or chains, which could become caught in the device.
- Wear safety glasses if you are working under any conditions that could be hazardous to your eyes.
- Do not perform any actions that create a potential hazard to people or make the equipment unsafe.
- Never attempt to lift an object that is too heavy for one person to handle.
- Never install or manipulate wiring during electrical storms.
- Never install electrical jacks in wet locations unless the jacks are specifically designed for wet environments.
- Operate the device only when it is properly grounded.
- Follow the instructions in this guide to properly ground the device to earth.
- Replace fuses only with fuses of the same type and rating.

- Do not open or remove chassis covers or sheet-metal parts unless instructions are provided in the hardware documentation for this device. Such an action could cause severe electrical shock.
- Do not push or force any objects through any opening in the chassis frame. Such an action could result in electrical shock or fire.
- Avoid spilling liquid onto the chassis or onto any device component. Such an action could cause electrical shock or damage the device.
- Avoid touching uninsulated electrical wires or terminals that have not been disconnected from their power source. Such an action could cause electrical shock.
- Some parts of the chassis, including AC and DC power supply surfaces, power supply unit handles, SFB card handles, and fan tray handles might become hot. The following label provides the warning for hot surfaces on the chassis:



- Always ensure that all modules, power supplies, and cover panels are fully inserted and that the installation screws are fully tightened.

Definitions of Safety Warning Levels

The documentation uses the following levels of safety warnings (there are two *Warning* formats):

NOTE: You might find this information helpful in a particular situation, or you might overlook this important information if it was not highlighted in a Note.



CAUTION: You need to observe the specified guidelines to prevent minor injury or discomfort to you or severe damage to the device.

Attention Veillez à respecter les consignes indiquées pour éviter toute incommodité ou blessure légère, voire des dégâts graves pour l'appareil.



LASER WARNING: This symbol alerts you to the risk of personal injury from a laser.

Avertissement Ce symbole signale un risque de blessure provoquée par rayon laser.



WARNING: This symbol means danger. You are in a situation that could cause bodily injury. Before you work on any equipment, be aware of the hazards involved with electrical circuitry, and familiarize yourself with standard practices for preventing accidents.

Waarschuwing Dit waarschuwingssymbool betekent gevaar. U verkeert in een situatie die lichamelijk letsel kan veroorzaken. Voordat u aan enige apparatuur gaat werken, dient u zich bewust te zijn van de bij elektrische schakelingen betrokken risico's en dient u op de hoogte te zijn van standaard maatregelen om ongelukken te voorkomen.

Varoitus Tämä varoitusmerkki merkitsee vaaraa. Olet tilanteessa, joka voi johtaa ruumiinvammaan. Ennen kuin työskentelet minkään laitteiston parissa, ota selvää sähkökytkentöihin liittyvistä vaaroista ja tavanomaisista onnettomuuksien ehkäisykeinoista.

Avertissement Ce symbole d'avertissement indique un danger. Vous vous trouvez dans une situation pouvant causer des blessures ou des dommages corporels. Avant de travailler sur un équipement, soyez conscient des dangers posés par les circuits électriques et familiarisez-vous avec les procédures couramment utilisées pour éviter les accidents.

Warnung Dieses Warnsymbol bedeutet Gefahr. Sie befinden sich in einer Situation, die zu einer Körperverletzung führen könnte. Bevor Sie mit der Arbeit an irgendeinem Gerät beginnen, seien Sie sich der mit elektrischen Stromkreisen verbundenen Gefahren und der Standardpraktiken zur Vermeidung von Unfällen bewußt.

Avvertenza Questo simbolo di avvertenza indica un pericolo. La situazione potrebbe causare infortuni alle persone. Prima di lavorare su qualsiasi apparecchiatura, occorre conoscere i pericoli relativi ai circuiti elettrici ed essere al corrente delle pratiche standard per la prevenzione di incidenti.

Advarsel Dette varselsymbolet betyr fare. Du befinner deg i en situasjon som kan føre til personskade. Før du utfører arbeid på utstyr, må du være oppmerksom på de faremomentene som elektriske kretser innebærer, samt gjøre deg kjent med vanlig praksis når det gjelder å unngå ulykker.

Aviso Este símbolo de aviso indica perigo. Encontra-se numa situação que lhe poderá causar danos físicos. Antes de começar a trabalhar com qualquer equipamento,

familiarize-se com os perigos relacionados com circuitos eléctricos, e com quaisquer práticas comuns que possam prevenir possíveis acidentes.

¡Atención! Este símbolo de aviso significa peligro. Existe riesgo para su integridad física. Antes de manipular cualquier equipo, considerar los riesgos que entraña la corriente eléctrica y familiarizarse con los procedimientos estándar de prevención de accidentes.

Warning! Denna varningssymbol signalerar fara. Du befinner dig i en situation som kan leda till personskada. Innan du utför arbete på någon utrustning måste du vara medveten om farorna med elkretsar och känna till vanligt förfarande för att förebygga skador.

Qualified Personnel Warning



WARNING: Only trained and qualified personnel should install or replace the device.

Waarschuwing Installatie en reparaties mogen uitsluitend door getraind en bevoegd personeel uitgevoerd worden.

Varoitus Ainoastaan koulutettu ja pätevä henkilökunta saa asentaa tai vaihtaa tämän laitteen.

Avertissement Tout installation ou remplacement de l'appareil doit être réalisé par du personnel qualifié et compétent.

Warnung Gerät nur von geschultem, qualifiziertem Personal installieren oder auswechseln lassen.

Avvertenza Solo personale addestrato e qualificato deve essere autorizzato ad installare o sostituire questo apparecchio.

Advarsel Kun kvalifisert personell med riktig opplæring bør montere eller bytte ut dette utstyret.

Aviso Este equipamento deverá ser instalado ou substituído apenas por pessoal devidamente treinado e qualificado.

¡Atención! Estos equipos deben ser instalados y reemplazados exclusivamente por personal técnico adecuadamente preparado y capacitado.

Varning! Denna utrustning ska endast installeras och bytas ut av utbildad och kvalificerad personal.

Warning Statement for Norway and Sweden



WARNING: The equipment must be connected to an earthed mains socket-outlet.

Advarsel Apparatet skal kobles til en jordet stikkontakt.

Varning! Apparaten skall anslutas till jordat nätuttag.

Fire Safety Requirements

IN THIS SECTION

- [Fire Suppression | 225](#)
- [Fire Suppression Equipment | 225](#)

In the event of a fire emergency, the safety of people is the primary concern. You should establish procedures for protecting people in the event of a fire emergency, provide safety training, and properly provision fire-control equipment and fire extinguishers.

In addition, you should establish procedures to protect your equipment in the event of a fire emergency. Juniper Networks products should be installed in an environment suitable for electronic equipment. We recommend that fire suppression equipment be available in the event of a fire in the vicinity of the equipment and that all local fire, safety, and electrical codes and ordinances be observed when you install and operate your equipment.

Fire Suppression

In the event of an electrical hazard or an electrical fire, you should first turn power off to the equipment at the source. Then use a Type C fire extinguisher, which uses noncorrosive fire retardants, to extinguish the fire.

Fire Suppression Equipment

Type C fire extinguishers, which use noncorrosive fire retardants such as carbon dioxide and Halotron™, are most effective for suppressing electrical fires. Type C fire extinguishers displace oxygen from the point of combustion to eliminate the fire. For extinguishing fire on or around equipment that draws air from the environment for cooling, you should use this type of inert oxygen displacement extinguisher instead of an extinguisher that leaves residues on equipment.

Do not use multipurpose Type ABC chemical fire extinguishers (dry chemical fire extinguishers). The primary ingredient in these fire extinguishers is monoammonium phosphate, which is very sticky and difficult to clean. In addition, in the presence of minute amounts of moisture, monoammonium phosphate can become highly corrosive and corrodes most metals.

Any equipment in a room in which a chemical fire extinguisher has been discharged is subject to premature failure and unreliable operation. The equipment is considered to be irreparably damaged.

NOTE: To keep warranties effective, do not use a dry chemical fire extinguisher to control a fire at or near a Juniper Networks device. If a dry chemical fire extinguisher is used, the unit is no longer eligible for coverage under a service agreement.

We recommend that you dispose of any irreparably damaged equipment in an environmentally responsible manner.

Installation Instructions Warning



WARNING: Read the installation instructions before you connect the device to a power source.

Waarschuwing Raadpleeg de installatie-aanwijzingen voordat u het systeem met de voeding verbindt.

Varoitus Lue asennusohjeet ennen järjestelmän yhdistämistä virtalähteeseen.

Avertissement Avant de brancher le système sur la source d'alimentation, consulter les directives d'installation.

Warnung Lesen Sie die Installationsanweisungen, bevor Sie das System an die Stromquelle anschließen.

Avvertenza Consultare le istruzioni di installazione prima di collegare il sistema all'alimentatore.

Advarsel Les installasjonsinstruksjonene før systemet kobles til strømkilden.

Aviso Leia as instruções de instalação antes de ligar o sistema à sua fonte de energia.

¡Atención! Ver las instrucciones de instalación antes de conectar el sistema a la red de alimentación.

Varning! Läs installationsanvisningarna innan du kopplar systemet till dess strömförsörjningsenhet.

Chassis and Component Lifting Guidelines

- Before moving the device to a site, ensure that the site meets the power, environmental, and clearance requirements.
- Before lifting or moving the device, disconnect all external cables and wires.
- As when lifting any heavy object, ensure that your legs bear most of the weight rather than your back. Keep your knees bent and your back relatively straight. Do not twist your body as you lift. Balance the load evenly and be sure that your footing is firm.
- Use the following lifting guidelines to lift devices and components:
 - Up to 39.7 lb (18 kg): One person.
 - From 39.7 lb (18 kg) to 70.5 lb (32 kg): Two or more people.
 - From 70.5 lb (32 kg) to 121.2 lb (55 kg): Three or more people.

- Above 121.2 lb (55 kg): Use material handling systems (such as levers, slings, lifts, and so on). When this is not practical, engage specially trained persons or systems (such as riggers or movers).

Restricted Access Warning



WARNING: This unit is intended for installation in restricted access areas. A restricted access area is an area to which access can be gained only by service personnel through the use of a special tool, lock and key, or other means of security, and which is controlled by the authority responsible for the location.

Waarschuwing Dit toestel is bedoeld voor installatie op plaatsen met beperkte toegang. Een plaats met beperkte toegang is een plaats waar toegang slechts door servicepersoneel verkregen kan worden door middel van een speciaal instrument, een slot en sleutel, of een ander veiligheidsmiddel, en welke beheerd wordt door de overheidsinstantie die verantwoordelijk is voor de locatie.

Varoitus Tämä laite on tarkoitettu asennettavaksi paikkaan, johon pääsy on rajoitettua. Paikka, johon pääsy on rajoitettua, tarkoittaa paikkaa, johon vain huoltohenkilöstö pääsee jonkin erikoistyökalun, lukkoon sopivan avaimen tai jonkin muun turvalaitteen avulla ja joka on paikasta vastuussa olevien toimivaltaisten henkilöiden valvoma.

Avertissement Cet appareil est à installer dans des zones d'accès réservé. Ces dernières sont des zones auxquelles seul le personnel de service peut accéder en utilisant un outil spécial, un mécanisme de verrouillage et une clé, ou tout autre moyen de sécurité. L'accès aux zones de sécurité est sous le contrôle de l'autorité responsable de l'emplacement.

Warnung Diese Einheit ist zur Installation in Bereichen mit beschränktem Zutritt vorgesehen. Ein Bereich mit beschränktem Zutritt ist ein Bereich, zu dem nur Wartungspersonal mit einem Spezialwerkzeugs, Schloß und Schlüssel oder anderer Sicherheitsvorkehrungen Zugang hat, und der von dem für die Anlage zuständigen Gremium kontrolliert wird.

Avvertenza Questa unità deve essere installata in un'area ad accesso limitato. Un'area ad accesso limitato è un'area accessibile solo a personale di assistenza tramite un'attrezzo speciale, lucchetto, o altri dispositivi di sicurezza, ed è controllata dall'autorità responsabile della zona.

Advarsel Denne enheten er laget for installasjon i områder med begrenset adgang. Et område med begrenset adgang gir kun adgang til servicepersonale som bruker et

spesielt verktøy, lås og nøkkel, eller en annen sikkerhetsanordning, og det kontrolleres av den autoriteten som er ansvarlig for området.

Aviso Esta unidade foi concebida para instalação em áreas de acesso restrito. Uma área de acesso restrito é uma área à qual apenas tem acesso o pessoal de serviço autorizado, que possua uma ferramenta, chave e fechadura especial, ou qualquer outra forma de segurança. Esta área é controlada pela autoridade responsável pelo local.

¡Atención! Esta unidad ha sido diseñada para instalarse en áreas de acceso restringido. Área de acceso restringido significa un área a la que solamente tiene acceso el personal de servicio mediante la utilización de una herramienta especial, cerradura con llave, o algún otro medio de seguridad, y que está bajo el control de la autoridad responsable del local.

Varning! Denna enhet är avsedd för installation i områden med begränsat tillträde. Ett område med begränsat tillträde får endast tillträdas av servicepersonal med ett speciellt verktyg, lås och nyckel, eller annan säkerhetsanordning, och kontrolleras av den auktoritet som ansvarar för området.

Ramp Warning



WARNING: When installing the device, do not use a ramp inclined at more than 10 degrees.

Waarschuwing Gebruik een oprijplaat niet onder een hoek van meer dan 10 graden.

Varoitus Älä käytä sellaista kaltevaa pintaa, jonka kaltevuus ylittää 10 astetta.

Avertissement Ne pas utiliser une rampe dont l'inclinaison est supérieure à 10 degrés.

Warnung Keine Rampen mit einer Neigung von mehr als 10 Grad verwenden.

Avvertenza Non usare una rampa con pendenza superiore a 10 gradi.

Advarsel Bruk aldri en rampe som heller mer enn 10 grader.

Aviso Não utilize uma rampa com uma inclinação superior a 10 graus.

¡Atención! No usar una rampa inclinada más de 10 grados.

Varning! Använd inte ramp med en lutning på mer än 10 grader.

Rack-Mounting and Cabinet-Mounting Warnings

Ensure that the rack or cabinet in which the device is installed is evenly and securely supported. Uneven mechanical loading could lead to a hazardous condition.



WARNING: To prevent bodily injury when mounting or servicing the device in a rack, take the following precautions to ensure that the system remains stable. The following directives help maintain your safety:

- Install the device in a rack that is secured to the building structure.
- Mount the device at the bottom of the rack if it is the only unit in the rack.
- When mounting the device on a partially filled rack, load the rack from the bottom to the top, with the heaviest component at the bottom of the rack.
- If the rack is provided with stabilizing equipment, install the stabilizers before mounting or servicing the device in the rack.

Waarschuwing Om lichamelijk letsel te voorkomen wanneer u dit toestel in een rek monteert of het daar een servicebeurt geeft, moet u speciale voorzorgsmaatregelen nemen om ervoor te zorgen dat het toestel stabiel blijft. De onderstaande richtlijnen worden verstrekt om uw veiligheid te verzekeren:

- De Juniper Networks switch moet in een stellage worden geïnstalleerd die aan een bouwsel is verankerd.
- Dit toestel dient onderaan in het rek gemonteerd te worden als het toestel het enige in het rek is.
- Wanneer u dit toestel in een gedeeltelijk gevuld rek monteert, dient u het rek van onderen naar boven te laden met het zwaarste onderdeel onderaan in het rek.
- Als het rek voorzien is van stabiliseringshulpmiddelen, dient u de stabilisatoren te monteren voordat u het toestel in het rek monteert of het daar een servicebeurt geeft.

Varoitus Kun laite asetetaan telineeseen tai huolletaan sen ollessa telineessä, on noudatettava erityisiä varotoimia järjestelmän vakavuuden säilyttämiseksi, jotta vältetään loukkaantumiselta. Noudata seuraavia turvallisuusohjeita:

- Juniper Networks switch on asennettava telineeseen, joka on kiinnitetty rakennukseen.
- Jos telineessä ei ole muita laitteita, aseta laite telineen alaosaan.
- Jos laite asetetaan osaksi täytettyyn telineeseen, aloita kuormittaminen sen alaosasta kaikkein raskaimmalla esineellä ja siirry sitten sen yläosaan.
- Jos telinettä varten on vakaimet, asenna ne ennen laitteen asettamista telineeseen tai sen huoltamista siinä.

Avertissement Pour éviter toute blessure corporelle pendant les opérations de montage ou de réparation de cette unité en casier, il convient de prendre des précautions spéciales afin de maintenir la stabilité du système. Les directives ci-dessous sont destinées à assurer la protection du personnel:

- Le rack sur lequel est monté le Juniper Networks switch doit être fixé à la structure du bâtiment.
- Si cette unité constitue la seule unité montée en casier, elle doit être placée dans le bas.
- Si cette unité est montée dans un casier partiellement rempli, charger le casier de bas en haut en plaçant l'élément le plus lourd dans le bas.
- Si le casier est équipé de dispositifs stabilisateurs, installer les stabilisateurs avant de monter ou de réparer l'unité en casier.

Warnung Zur Vermeidung von Körperverletzung beim Anbringen oder Warten dieser Einheit in einem Gestell müssen Sie besondere Vorkehrungen treffen, um sicherzustellen, daß das System stabil bleibt. Die folgenden Richtlinien sollen zur Gewährleistung Ihrer Sicherheit dienen:

- Der Juniper Networks switch muß in einem Gestell installiert werden, das in der Gebäudestruktur verankert ist.
- Wenn diese Einheit die einzige im Gestell ist, sollte sie unten im Gestell angebracht werden.
- Bei Anbringung dieser Einheit in einem zum Teil gefüllten Gestell ist das Gestell von unten nach oben zu laden, wobei das schwerste Bauteil unten im Gestell anzubringen ist.

- Wird das Gestell mit Stabilisierungszubehör geliefert, sind zuerst die Stabilisatoren zu installieren, bevor Sie die Einheit im Gestell anbringen oder sie warten.

Avvertenza Per evitare infortuni fisici durante il montaggio o la manutenzione di questa unità in un supporto, occorre osservare speciali precauzioni per garantire che il sistema rimanga stabile. Le seguenti direttive vengono fornite per garantire la sicurezza personale:

- Il Juniper Networks switch deve essere installato in un telaio, il quale deve essere fissato alla struttura dell'edificio.
- Questa unità deve venire montata sul fondo del supporto, se si tratta dell'unica unità da montare nel supporto.
- Quando questa unità viene montata in un supporto parzialmente pieno, caricare il supporto dal basso all'alto, con il componente più pesante sistemato sul fondo del supporto.
- Se il supporto è dotato di dispositivi stabilizzanti, installare tali dispositivi prima di montare o di procedere alla manutenzione dell'unità nel supporto.

Advarsel Unngå fysiske skader under montering eller reparasjonsarbeid på denne enheten når den befinner seg i et kabinett. Vær nøye med at systemet er stabilt. Følgende retningslinjer er gitt for å verne om sikkerheten:

- Juniper Networks switch må installeres i et stativ som er forankret til bygningsstrukturen.
- Denne enheten bør monteres nederst i kabinettet hvis dette er den eneste enheten i kabinettet.
- Ved montering av denne enheten i et kabinett som er delvis fylt, skal kabinettet lastes fra bunnen og opp med den tyngste komponenten nederst i kabinettet.
- Hvis kabinettet er utstyrt med stabiliseringsutstyr, skal stabilisatorene installeres før montering eller utføring av reparasjonsarbeid på enheten i kabinettet.

Aviso Para se prevenir contra danos corporais ao montar ou reparar esta unidade numa estante, deverá tomar precauções especiais para se certificar de que o sistema possui um suporte estável. As seguintes directrizes ajudá-lo-ão a efectuar o seu trabalho com segurança:

- O Juniper Networks switch deverá ser instalado numa prateleira fixa à estrutura do edifício.

- Esta unidade deverá ser montada na parte inferior da estante, caso seja esta a única unidade a ser montada.
- Ao montar esta unidade numa estante parcialmente ocupada, coloque os itens mais pesados na parte inferior da estante, arrumando-os de baixo para cima.
- Se a estante possuir um dispositivo de estabilização, instale-o antes de montar ou reparar a unidade.

¡Atención! Para evitar lesiones durante el montaje de este equipo sobre un bastidor, oerriormente durante su mantenimiento, se debe poner mucho cuidado en que el sistema quede bien estable. Para garantizar su seguridad, proceda según las siguientes instrucciones:

- El Juniper Networks switch debe instalarse en un bastidor fijado a la estructura del edificio.
- Colocar el equipo en la parte inferior del bastidor, cuando sea la única unidad en el mismo.
- Cuando este equipo se vaya a instalar en un bastidor parcialmente ocupado, comenzar la instalación desde la parte inferior hacia la superior colocando el equipo más pesado en la parte inferior.
- Si el bastidor dispone de dispositivos estabilizadores, instalar éstos antes de montar o proceder al mantenimiento del equipo instalado en el bastidor.

Warning! För att undvika kroppsskada när du installerar eller utför underhållsarbete på denna enhet på en ställning måste du vidta särskilda försiktighetsåtgärder för att försäkra dig om att systemet står stadigt. Följande riktlinjer ges för att trygga din säkerhet:

- Juniper Networks switch måste installeras i en ställning som är förankrad i byggnadens struktur.
- Om denna enhet är den enda enheten på ställningen skall den installeras längst ned på ställningen.
- Om denna enhet installeras på en delvis fylld ställning skall ställningen fyllas nedifrån och upp, med de tyngsta enheterna längst ned på ställningen.
- Om ställningen är försedd med stabiliseringsdon skall dessa monteras fast innan enheten installeras eller underhålls på ställningen.

Grounded Equipment Warning



WARNING: This device must be properly grounded at all times. Follow the instructions in this guide to properly ground the device to earth.

Waarschuwing Dit apparaat moet altijd goed geaard zijn. Volg de instructies in deze gids om het apparaat goed te aarden.

Varoitus Laitteen on oltava pysyvästi maadoitettu. Maadoita laite asianmukaisesti noudattamalla tämän oppaan ohjeita.

Avertissement L'appareil doit être correctement mis à la terre à tout moment. Suivez les instructions de ce guide pour correctement mettre l'appareil à la terre.

Warnung Das Gerät muss immer ordnungsgemäß geerdet sein. Befolgen Sie die Anweisungen in dieser Anleitung, um das Gerät ordnungsgemäß zu erden.

Avvertenza Questo dispositivo deve sempre disporre di una connessione a massa. Seguire le istruzioni indicate in questa guida per connettere correttamente il dispositivo a massa.

Advarsel Denne enheten på jordes skikkelig hele tiden. Følg instruksjonene i denne veiledningen for å jorde enheten.

Aviso Este equipamento deverá estar ligado à terra. Siga las instrucciones en esta guía para conectar correctamente este dispositivo a tierra.

¡Atención! Este dispositivo debe estar correctamente conectado a tierra en todo momento. Siga las instrucciones en esta guía para conectar correctamente este dispositivo a tierra.

Warning! Den här enheten måste vara ordentligt jordad. Följ instruktionerna i den här guiden för att jorda enheten ordentligt.

Radiation from Open Port Apertures Warning



LASER WARNING: Because invisible radiation might be emitted from the aperture of the port when no fiber cable is connected, avoid exposure to radiation and do not stare into open apertures.

Waarschuwing Aangezien onzichtbare straling vanuit de opening van de poort kan komen als er geen fiberkabel aangesloten is, dient blootstelling aan straling en het kijken in open openingen vermeden te worden.

Varoitus Koska portin aukosta voi emittoitua näkymätöntä säteilyä, kun kuitukaapelia ei ole kytkettyä, vältä säteilylle altistumista äläkä katso avoimiin aukkoihin.

Avertissement Des radiations invisibles à l'il nu pouvant traverser l'ouverture du port lorsqu'aucun câble en fibre optique n'y est connecté, il est recommandé de ne pas regarder fixement l'intérieur de ces ouvertures.

Warnung Aus der Port-Öffnung können unsichtbare Strahlen emittieren, wenn kein Glasfaserkabel angeschlossen ist. Vermeiden Sie es, sich den Strahlungen auszusetzen, und starren Sie nicht in die Öffnungen!

Avvertenza Quando i cavi in fibra non sono inseriti, radiazioni invisibili possono essere emesse attraverso l'apertura della porta. Evitate di esporvi alle radiazioni e non guardate direttamente nelle aperture.

Advarsel Unngå utsettelse for stråling, og stirr ikke inn i åpninger som er åpne, fordi usynlig stråling kan emitteres fra portens åpning når det ikke er tilkoblet en fiberkabel.

Aviso Dada a possibilidade de emissão de radiação invisível através do orifício da via de acesso, quando esta não tiver nenhum cabo de fibra conectado, deverá evitar a EXposição à radiação e não deverá olhar fixamente para orifícios que se encontrarem a descoberto.

¡Atención! Debido a que la apertura del puerto puede emitir radiación invisible cuando no existe un cable de fibra conectado, evite mirar directamente a las aperturas para no exponerse a la radiación.

Warning! Osynlig strålning kan avges från en portöppning utan ansluten fiberkabel och du bör därför undvika att bli utsatt för strålning genom att inte stirra in i oskyddade öppningar.

Laser and LED Safety Guidelines and Warnings

IN THIS SECTION

● [General Laser Safety Guidelines | 235](#)

- [Class 1 Laser Product Warning | 236](#)
- [Class 1 LED Product Warning | 236](#)
- [Laser Beam Warning | 237](#)

Juniper Networks devices are equipped with laser transmitters, which are considered a Class 1 Laser Product by the U.S. Food and Drug Administration and are evaluated as a Class 1 Laser Product per IEC/EN 60825-1 requirements.

Observe the following guidelines and warnings:

General Laser Safety Guidelines

When working around ports that support optical transceivers, observe the following safety guidelines to prevent eye injury:

- Do not look into unterminated ports or at fibers that connect to unknown sources.
- Do not examine unterminated optical ports with optical instruments.
- Avoid direct exposure to the beam.



LASER WARNING: Unterminated optical connectors can emit invisible laser radiation. The lens in the human eye focuses all the laser power on the retina, so focusing the eye directly on a laser source—even a low-power laser—could permanently damage the eye.

Avertissement Les connecteurs à fibre optique sans terminaison peuvent émettre un rayonnement laser invisible. Le cristallin de l'œil humain faisant converger toute la puissance du laser sur la rétine, toute focalisation directe de l'œil sur une source laser, —même de faible puissance—, peut entraîner des lésions oculaires irréversibles.

Class 1 Laser Product Warning



LASER WARNING: Class 1 laser product.

Waarschuwing Klasse-1 laser produkt.

Varoitus Luokan 1 lasertuote.

Avertissement Produit laser de classe I.

Warnung Laserprodukt der Klasse 1.

Avvertenza Prodotto laser di Classe 1.

Advarsel Laserprodukt av klasse 1.

Aviso Produto laser de classe 1.

¡Atención! Producto láser Clase I.

Varning! Laserprodukt av klass 1.

Class 1 LED Product Warning



LASER WARNING: Class 1 LED product.

Waarschuwing Klasse 1 LED-product.

Varoitus Luokan 1 valodiodituote.

Avertissement Alarme de produit LED Class I.

Warnung Class 1 LED-Produktwarnung.

Avvertenza Avvertenza prodotto LED di Classe 1.

Advarsel LED-produkt i klasse 1.

Aviso Produto de classe 1 com LED.

¡Atención! Aviso sobre producto LED de Clase 1.

Varning! Lysdiodprodukt av klass 1.

Laser Beam Warning



LASER WARNING: Do not stare into the laser beam or view it directly with optical instruments.

Waarschuwing Niet in de straal staren of hem rechtstreeks bekijken met optische instrumenten.

Varoitus Älä katso säteeseen äläkä tarkastele sitä suoraan optisen laitteen avulla.

Avertissement Ne pas fixer le faisceau des yeux, ni l'observer directement à l'aide d'instruments optiques.

Warnung Nicht direkt in den Strahl blicken und ihn nicht direkt mit optischen Geräten prüfen.

Avvertenza Non fissare il raggio con gli occhi né usare strumenti ottici per osservarlo direttamente.

Advarsel Stirr eller se ikke direkte p strlen med optiske instrumenter.

Aviso Não olhe fixamente para o raio, nem olhe para ele directamente com instrumentos ópticos.

¡Atención! No mirar fijamente el haz ni observarlo directamente con instrumentos ópticos.

Warning! Rikta inte blicken in mot strålen och titta inte direkt på den genom optiska instrument.

Maintenance and Operational Safety Guidelines and Warnings

IN THIS SECTION

- [Battery Handling Warning | 238](#)
- [Jewelry Removal Warning | 239](#)
- [Lightning Activity Warning | 240](#)

- Operating Temperature Warning | 241
- Product Disposal Warning | 242

While performing the maintenance activities for devices, observe the following guidelines and warnings:

Battery Handling Warning



WARNING: Replacing a battery incorrectly might result in an explosion. Replace a battery only with the same or equivalent type recommended by the manufacturer. Dispose of used batteries according to the manufacturer's instructions.

Waarschuwing Er is ontploffingsgevaar als de batterij verkeerd vervangen wordt. Vervang de batterij slechts met hetzelfde of een equivalent type dat door de fabrikant aanbevolen is. Gebruikte batterijen dienen overeenkomstig fabrieksvoorschriften weggeworpen te worden.

Varoitus Räjähdyksen vaara, jos akku on vaihdettu väärään akkuun. Käytä vaihtamiseen ainoastaan saman- tai vastaavantyyppistä akkua, joka on valmistajan suosittama. Hävitä käytetyt akut valmistajan ohjeiden mukaan.

Avertissement Danger d'explosion si la pile n'est pas remplacée correctement. Ne la remplacer que par une pile de type semblable ou équivalent, recommandée par le fabricant. Jeter les piles usagées conformément aux instructions du fabricant.

Warnung Bei Einsetzen einer falschen Batterie besteht Explosionsgefahr. Ersetzen Sie die Batterie nur durch den gleichen oder vom Hersteller empfohlenen Batterietyp. Entsorgen Sie die benutzten Batterien nach den Anweisungen des Herstellers.

Advarsel Det kan være fare for eksplosjon hvis batteriet skiftes på feil måte. Skift kun med samme eller tilsvarende type som er anbefalt av produsenten. Kasser brukte batterier i henhold til produsentens instruksjoner.

Avvertenza Pericolo di esplosione se la batteria non è installata correttamente. Sostituire solo con una di tipo uguale o equivalente, consigliata dal produttore. Eliminare le batterie usate secondo le istruzioni del produttore.

Aviso Existe perigo de explosão se a bateria for substituída incorrectamente. Substitua a bateria por uma bateria igual ou de um tipo equivalente recomendado pelo fabricante. Destrua as baterias usadas conforme as instruções do fabricante.

¡Atención! Existe peligro de explosión si la batería se reemplaza de manera incorrecta. Reemplazar la batería EXclusivamente con el mismo tipo o el equivalente recomendado por el fabricante. Desechar las baterías gastadas según las instrucciones del fabricante.

Warning! Explosionsfara vid felaktigt batteribyte. Ersätt endast batteriet med samma batterityp som rekommenderas av tillverkaren eller motsvarande. Följ tillverkarens anvisningar vid kassering av använda batterier.

Jewelry Removal Warning



WARNING: Before working on equipment that is connected to power lines, remove jewelry, including rings, necklaces, and watches. Metal objects heat up when connected to power and ground and can cause serious burns or can be welded to the terminals.

Waarschuwing Alvorens aan apparatuur te werken die met elektrische leidingen is verbonden, sieraden (inclusief ringen, kettingen en horloges) verwijderen. Metalen voorwerpen worden warm wanneer ze met stroom en aarde zijn verbonden, en kunnen ernstige brandwonden veroorzaken of het metalen voorwerp aan de aansluitklemmen lassen.

Varoitus Ennen kuin työskentelet voimavirtajohtoihin kytkettyjen laitteiden parissa, ota pois kaikki korut (sormukset, kaulakorut ja kellot mukaan lukien). Metalliesineet kuumenevat, kun ne ovat yhteydessä sähkövirran ja maan kanssa, ja ne voivat aiheuttaa vakavia palovammoja tai hitsata metalliesineet kiinni liitännänapoihin.

Avertissement Avant d'accéder à cet équipement connecté aux lignes électriques, ôter tout bijou (anneaux, colliers et montres compris). Lorsqu'ils sont branchés à l'alimentation et reliés à la terre, les objets métalliques chauffent, ce qui peut provoquer des blessures graves ou souder l'objet métallique aux bornes.

Warnung Vor der Arbeit an Geräten, die an das Netz angeschlossen sind, jeglichen Schmuck (einschließlich Ringe, Ketten und Uhren) abnehmen. Metallgegenstände erhitzen sich, wenn sie an das Netz und die Erde angeschlossen werden, und können schwere Verbrennungen verursachen oder an die Anschlußklemmen angeschweißt werden.

Avvertenza Prima di intervenire su apparecchiature collegate alle linee di alimentazione, togliersi qualsiasi monile (inclusi anelli, collane, braccialetti ed orologi). Gli oggetti metallici si riscaldano quando sono collegati tra punti di alimentazione e massa: possono causare ustioni gravi oppure il metallo può saldarsi ai terminali.

Advarsel Fjern alle smykker (inkludert ringe, halskjeder og klokker) før du skal arbeide på utstyr som er koblet til kraftledninger. Metallgjenstander som er koblet til kraftledninger og jord blir svært varme og kan forårsake alvorlige brannskader eller smelte fast til polene.

Aviso Antes de trabalhar em equipamento que esteja ligado a linhas de corrente, retire todas as jóias que estiver a usar (incluindo anéis, fios e relógios). Os objectos metálicos aquecerão em contacto com a corrente e em contacto com a ligação à terra, podendo causar queimaduras graves ou ficarem soldados aos terminais.

¡Atención! Antes de operar sobre equipos conectados a líneas de alimentación, quitarse las joyas (incluidos anillos, collares y relojes). Los objetos de metal se calientan cuando se conectan a la alimentación y a tierra, lo que puede ocasionar quemaduras graves o que los objetos metálicos queden soldados a los bornes.

Warning! Tag av alla smycken (inklusive ringar, halsband och armbandsur) innan du arbetar på utrustning som är kopplad till kraftledningar. Metallobjekt hettas upp när de kopplas ihop med ström och jord och kan förorsaka allvarliga brännskador; metallobjekt kan också sammansvetsas med kontakterna.

Lightning Activity Warning



WARNING: Do not work on the system or connect or disconnect cables during periods of lightning activity.

Waarschuwing Tijdens onweer dat gepaard gaat met bliksem, dient u niet aan het systeem te werken of kabels aan te sluiten of te ontkoppelen.

Varoitus Älä työskentele järjestelmän parissa äläkä yhdistä tai irrota kaapeleita ukkosilmalla.

Avertissement Ne pas travailler sur le système ni brancher ou débrancher les câbles pendant un orage.

Warnung Arbeiten Sie nicht am System und schließen Sie keine Kabel an bzw. trennen Sie keine ab, wenn es gewittert.

Avvertenza Non lavorare sul sistema o collegare oppure scollegare i cavi durante un temporale con fulmini.

Advarsel Utfør aldri arbeid på systemet, eller koble kabler til eller fra systemet når det tordner eller lynner.

Aviso Não trabalhe no sistema ou ligue e desligue cabos durante períodos de mau tempo (trovoada).

¡Atención! No operar el sistema ni conectar o desconectar cables durante el transcurso de descargas eléctricas en la atmósfera.

Warning! Vid åska skall du aldrig utföra arbete på systemet eller ansluta eller koppla loss kablar.

Operating Temperature Warning



WARNING: To prevent the device from overheating, do not operate it in an area that exceeds the maximum recommended ambient temperature. To prevent airflow restriction, allow at least 6 in. (15.2 cm) of clearance around the ventilation openings.

Waarschuwing Om te voorkomen dat welke switch van de Juniper Networks router dan ook oververhit raakt, dient u deze niet te bedienen op een plaats waar de maximale aanbevolen omgevingstemperatuur van 40° C wordt overschreden. Om te voorkomen dat de luchtstroom wordt beperkt, dient er minstens 15,2 cm speling rond de ventilatie-openingen te zijn.

Varoitus Ettei Juniper Networks switch-sarjan reititin ylikuumentuisi, sitä ei saa käyttää tilassa, jonka lämpötila ylittää korkeimman suositellun ympäristölämpötilan 40° C. Ettei ilmanvaihto estyisi, tuuletusaukkojen ympärille on jätettävä ainakin 15,2 cm tilaa.

Avertissement Pour éviter toute surchauffe des routeurs de la gamme Juniper Networks switch, ne l'utilisez pas dans une zone où la température ambiante est supérieure à 40° C. Pour permettre un flot d'air constant, dégagez un espace d'au moins 15,2 cm autour des ouvertures de ventilations.

Warnung Um einen Router der switch vor Überhitzung zu schützen, darf dieser nicht in einer Gegend betrieben werden, in der die Umgebungstemperatur das empfohlene

Maximum von 40° C überschreitet. Um Lüftungsverschluß zu verhindern, achten Sie darauf, daß mindestens 15,2 cm lichter Raum um die Lüftungsöffnungen herum frei bleibt.

Avvertenza Per evitare il surriscaldamento dei switch, non adoperateli in un locale che ecceda la temperatura ambientale massima di 40° C. Per evitare che la circolazione dell'aria sia impedita, lasciate uno spazio di almeno 15.2 cm di fronte alle aperture delle ventole.

Advarsel Unngå overoppheting av eventuelle rutere i Juniper Networks switch Disse skal ikke brukes på steder der den anbefalte maksimale omgivelsestemperaturen overstiger 40° C (104° F). Sørg for at klaringen rundt lufteåpningene er minst 15,2 cm (6 tommer) for å forhindre nedsatt luftsirkulasjon.

Aviso Para evitar o sobreaquecimento do encaminhador Juniper Networks switch, não utilize este equipamento numa área que exceda a temperatura máxima recomendada de 40° C. Para evitar a restrição à circulação de ar, deixe pelo menos um espaço de 15,2 cm à volta das aberturas de ventilação.

¡Atención! Para impedir que un encaminador de la serie Juniper Networks switch se recaliente, no lo haga funcionar en un área en la que se supere la temperatura ambiente máxima recomendada de 40° C. Para impedir la restricción de la entrada de aire, deje un espacio mínimo de 15,2 cm alrededor de las aperturas para ventilación.

Warning! Förhindra att en Juniper Networks switch överhettas genom att inte använda den i ett område där den maximalt rekommenderade omgivningstemperaturen på 40° C överskrids. Förhindra att luftcirkulationen inskränks genom att se till att det finns fritt utrymme på minst 15,2 cm omkring ventilationsöppningarna.

Product Disposal Warning



WARNING: Disposal of this device must be handled according to all national laws and regulations.

Waarschuwing Dit produkt dient volgens alle landelijke wetten en voorschriften te worden afgedankt.

Varoitus Tämän tuotteen lopullisesta hävittämisestä tulee huolehtia kaikkia valtakunnallisia lakeja ja säännöksiä noudattaen.

Avertissement La mise au rebut définitive de ce produit doit être effectuée conformément à toutes les lois et réglementations en vigueur.

Warnung Dieses Produkt muß den geltenden Gesetzen und Vorschriften entsprechend entsorgt werden.

Avvertenza L'eliminazione finale di questo prodotto deve essere eseguita osservando le normative italiane vigenti in materia

Advarsel Endelig disponering av dette produktet må skje i henhold til nasjonale lover og forskrifter.

Aviso A descartagem final deste produto deverá ser efectuada de acordo com os regulamentos e a legislação nacional.

¡Atención! El desecho final de este producto debe realizarse según todas las leyes y regulaciones nacionales

Warning! Slutlig kassering av denna produkt bör skötas i enlighet med landets alla lagar och föreskrifter.

General Electrical Safety Guidelines and Warnings



WARNING: Certain ports on the device are designed for use as intrabuilding (within-the-building) interfaces only (Type 2 or Type 4 ports as described in *GR-1089-CORE*) and require isolation from the exposed outside plant (OSP) cabling. To comply with NEBS (Network Equipment-Building System) requirements and protect against lightning surges and commercial power disturbances, the intrabuilding ports *must not* be metallically connected to interfaces that connect to the OSP or its wiring. The intrabuilding ports on the device are suitable for connection to intrabuilding or unexposed wiring or cabling only. The addition of primary protectors is not sufficient protection for connecting these interfaces metallically to OSP wiring.

Avertissement Certains ports de l'appareil sont destinés à un usage en intérieur uniquement (ports Type 2 ou Type 4 tels que décrits dans le document *GR-1089-CORE*) et doivent être isolés du câblage de l'installation extérieure exposée. Pour respecter les exigences NEBS et assurer une protection contre la foudre et les perturbations de tension secteur, les ports pour intérieur *ne doivent pas* être raccordés physiquement aux interfaces prévues pour la connexion à l'installation extérieure ou à son câblage. Les

ports pour intérieur de l'appareil sont réservés au raccordement de câbles pour intérieur ou non exposés uniquement. L'ajout de protections ne constitue pas une précaution suffisante pour raccorder physiquement ces interfaces au câblage de l'installation extérieure.



CAUTION: Before removing or installing components of a device, connect an electrostatic discharge (ESD) grounding strap to an ESD point and wrap and fasten the other end of the strap around your bare wrist. Failure to use an ESD grounding strap could result in damage to the device.

Attention Avant de retirer ou d'installer des composants d'un appareil, raccordez un bracelet antistatique à un point de décharge électrostatique et fixez le bracelet à votre poignet nu. L'absence de port d'un bracelet antistatique pourrait provoquer des dégâts sur l'appareil.

- Install the device in compliance with the following local, national, and international electrical codes:
 - United States—National Fire Protection Association (NFPA 70), United States National Electrical Code.
 - Other countries—International Electromechanical Commission (IEC) 60364, Part 1 through Part 7.
 - Evaluated to the TN power system.
 - Canada—Canadian Electrical Code, Part 1, CSA C22.1.
 - Suitable for installation in Information Technology Rooms in accordance with Article 645 of the National Electrical Code and NFPA 75.

Peut être installé dans des salles de matériel de traitement de l'information conformément à l'article 645 du National Electrical Code et à la NFPA 75.
- Locate the emergency power-off switch for the room in which you are working so that if an electrical accident occurs, you can quickly turn off the power.
- Make sure that you clean grounding surface and give them a bright finish before making grounding connections.
- Do not work alone if potentially hazardous conditions exist anywhere in your workspace.
- Never assume that power is disconnected from a circuit. Always check the circuit before starting to work.
- Carefully look for possible hazards in your work area, such as moist floors, ungrounded power extension cords, and missing safety grounds.

- Operate the device within marked electrical ratings and product usage instructions.
- To ensure that the device and peripheral equipment function safely and correctly, use the cables and connectors specified for the attached peripheral equipment, and make certain they are in good condition.

You can remove and replace many device components without powering off or disconnecting power to the device, as detailed elsewhere in the hardware documentation for this device. Never install equipment that appears to be damaged.

Action to Take After an Electrical Accident

If an electrical accident results in an injury, take the following actions in this order:

1. Use caution. Be aware of potentially hazardous conditions that could cause further injury.
2. Disconnect power from the device.
3. If possible, send another person to get medical aid. Otherwise, assess the condition of the victim, and then call for help.

Prevention of Electrostatic Discharge Damage

Device components that are shipped in antistatic bags are sensitive to damage from static electricity. Some components can be impaired by voltages as low as 30 V. You can easily generate potentially damaging static voltages whenever you handle plastic or foam packing material or if you move components across plastic or carpets. Observe the following guidelines to minimize the potential for electrostatic discharge (ESD) damage, which can cause intermittent or complete component failures:

- Always use an ESD wrist strap when you are handling components that are subject to ESD damage, and make sure that it is in direct contact with your skin.

If a grounding strap is not available, hold the component in its antistatic bag (see [Figure 129 on page 246](#)) in one hand and touch the exposed, bare metal of the device with the other hand immediately before inserting the component into the device.



WARNING: For safety, periodically check the resistance value of the ESD grounding strap. The measurement must be in the range 1 through 10 Mohms.

Avertissement Par mesure de sécurité, vérifiez régulièrement la résistance du bracelet antistatique. Cette valeur doit être comprise entre 1 et 10 mégohms (Mohms).

- When handling any component that is subject to ESD damage and that is removed from the device, make sure the equipment end of your ESD wrist strap is attached to the ESD point on the chassis.

If no grounding strap is available, touch the exposed, bare metal of the device to ground yourself before handling the component.

- Avoid contact between the component that is subject to ESD damage and your clothing. ESD voltages emitted from clothing can damage components.
- When removing or installing a component that is subject to ESD damage, always place it component-side up on an antistatic surface, in an antistatic card rack, or in an antistatic bag (see [Figure 129 on page 246](#)). If you are returning a component, place it in an antistatic bag before packing it.

Figure 129: Placing a Component into an Antistatic Bag

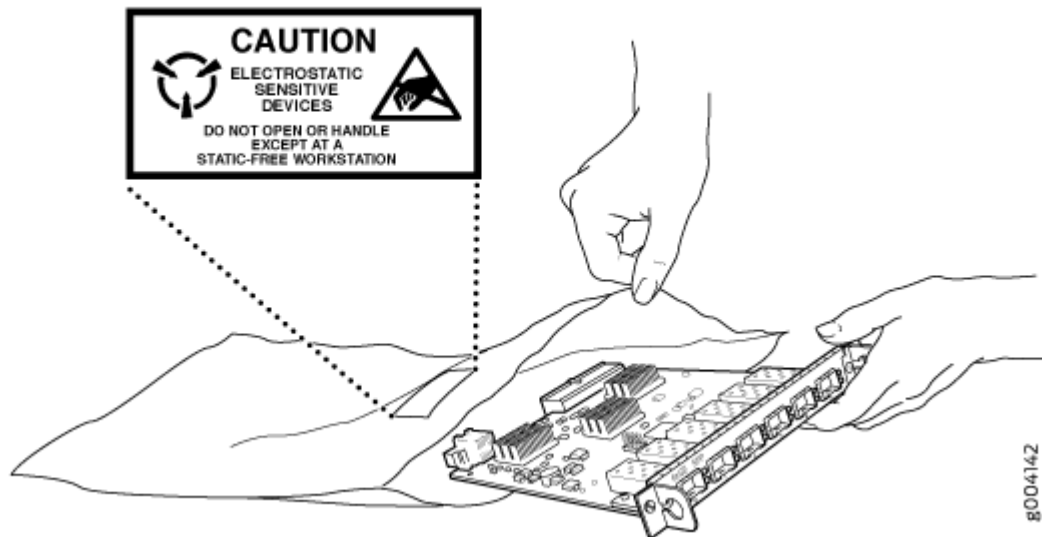

g004142



CAUTION: ANSI/TIA/EIA-568 cables such as Category 5e and Category 6 can get electrostatically charged. To dissipate this charge, always ground the cables to a suitable and safe earth ground before connecting them to the system.

Attention Les câbles ANSI/TIA/EIA-568, par exemple Cat 5e et Cat 6, peuvent emmagasiner des charges électrostatiques. Pour évacuer ces charges, reliez toujours les câbles à une prise de terre adaptée avant de les raccorder au système.

AC Power Electrical Safety Guidelines

The following electrical safety guidelines apply to AC-powered devices:

- Note the following warnings printed on the device:

“CAUTION: THIS UNIT HAS MORE THAN ONE POWER SUPPLY CORD. DISCONNECT ALL POWER SUPPLY CORDS BEFORE SERVICING TO AVOID ELECTRIC SHOCK.”

“ATTENTION: CET APPAREIL COMPORTE PLUS D'UN CORDON D'ALIMENTATION. AFIN DE PRÉVENIR LES CHOCS ÉLECTRIQUES, DÉBRANCHER TOUT CORDON D'ALIMENTATION AVANT DE FAIRE LE DÉPANNAGE.”

- AC-powered devices are shipped with a three-wire electrical cord with a grounding-type plug that fits only a grounding-type power outlet. Do not circumvent this safety feature. Equipment grounding must comply with local and national electrical codes.
- You must provide an external certified circuit breaker (2-pole circuit breaker or 4-pole circuit breaker based on your device) rated minimum 20 A in the building installation.
- The power cord serves as the main disconnecting device for the AC-powered device. The socket outlet must be near the AC-powered device and be easily accessible.
- For devices that have more than one power supply connection, you must ensure that all power connections are fully disconnected so that power to the device is completely removed to prevent electric shock. To disconnect power, unplug all power cords (one for each power supply).

Power Cable Warning (Japanese)

WARNING: The attached power cable is only for this product. Do not use the cable for another product.

注意

附属の電源コードセットはこの製品専用です。
他の電気機器には使用しないでください。

0477081

AC Power Disconnection Warning



WARNING: Before working on the device or near power supplies, unplug all the power cords from an AC-powered device.

Waarschuwing Voordat u aan een frame of in de nabijheid van voedingen werkt, dient u bij wisselstroom toestellen de stekker van het netsnoer uit het stopcontact te halen.

Varoitus Kytke irti vaihtovirtalaitteiden virtajohto, ennen kuin teet mitään asennuspohjalle tai työskentelet virtalähteiden läheisyydessä.

Avertissement Avant de travailler sur un châssis ou à proximité d'une alimentation électrique, débrancher le cordon d'alimentation des unités en courant alternatif.

Warnung Bevor Sie an einem Chassis oder in der Nähe von Netzgeräten arbeiten, ziehen Sie bei Wechselstromeinheiten das Netzkabel ab bzw.

Avvertenza Prima di lavorare su un telaio o intorno ad alimentatori, scollegare il cavo di alimentazione sulle unità CA.

Advarsel Før det utføres arbeid på kabinettet eller det arbeides i nærheten av strømforsyningsenheter, skal strømledningen trekkes ut på vekselstrømsenheter.

Aviso Antes de trabalhar num chassis, ou antes de trabalhar perto de unidades de fornecimento de energia, desligue o cabo de alimentação nas unidades de corrente alternada.

¡Atención! Antes de manipular el chasis de un equipo o trabajar cerca de una fuente de alimentación, desenchufar el cable de alimentación en los equipos de corriente alterna (CA).

Varning! Innan du arbetar med ett chassi eller nära strömförsörjningsenheter skall du för växelströmsenheter dra ur nätsladden.

DC Power Electrical Safety Guidelines

- A DC-powered device is equipped with a DC terminal block that is rated for the power requirements of a maximally configured device.
- For permanently connected equipment, a readily accessible disconnect device shall be incorporated external to the equipment.
- For pluggable equipment, the socket-outlet shall be installed near the equipment and shall be easily accessible.
- Be sure to connect the ground wire or conduit to a solid central office earth ground.
- A closed loop ring is recommended for terminating the ground conductor at the ground stud.
- Run two wires from the circuit breaker box to a source of 48 VDC.
- A DC-powered device that is equipped with a DC terminal block is intended only for installation in a restricted-access location. In the United States, a restricted-access area is one in accordance with Articles 110-16, 110-17, and 110-18 of the National Electrical Code ANSI/NFPA 70.

NOTE: Primary overcurrent protection is provided by the building circuit breaker. This breaker must protect against excess currents, short circuits, and earth grounding faults in accordance with NEC ANSI/NFPA 70.

- Ensure that the polarity of the DC input wiring is correct. Under certain conditions, connections with reversed polarity might trip the primary circuit breaker or damage the equipment.
- The marked input voltage of -48 VDC for a DC-powered device is the nominal voltage associated with the battery circuit, and any higher voltages are only to be associated with float voltages for the charging function.

- Because the device is a positive ground system, you must connect the positive lead to the terminal labeled **RTN**, the negative lead to the terminal labeled **-48 VDC**, and the earth ground to the device grounding points.

DC Power Disconnection Warning



WARNING: Before performing any of the DC power procedures, ensure that power is removed from the DC circuit. To ensure that all power is off, locate the circuit breaker on the panel board that services the DC circuit, switch the circuit breaker to the OFF position, and tape the device handle of the circuit breaker in the OFF position.

Waarschuwing Voordat u een van de onderstaande procedures uitvoert, dient u te controleren of de stroom naar het gelijkstroom circuit uitgeschakeld is. Om u ervan te verzekeren dat alle stroom UIT is geschakeld, kiest u op het schakelbord de stroomverbreker die het gelijkstroom circuit bedient, draait de stroomverbreker naar de UIT positie en plakt de schakelaarhendel van de stroomverbreker met plakband in de UIT positie vast.

Varoitus Varmista, että tasavirtapiirissä ei ole virtaa ennen seuraavien toimenpiteiden suorittamista. Varmistaaksesi, että virta on KATKAISTU täysin, paikanna tasavirrasta huolehtivassa kojetaulussa sijaitseva suojakytkin, käännä suojakytkin KATKAISTU-asentoon ja teippaa suojakytkimen varsi niin, että se pysyy KATKAISTU-asennossa.

Avertissement Avant de pratiquer l'une quelconque des procédures ci-dessous, vérifier que le circuit en courant continu n'est plus sous tension. Pour en être sûr, localiser le disjoncteur situé sur le panneau de service du circuit en courant continu, placer le disjoncteur en position fermée (OFF) et, à l'aide d'un ruban adhésif, bloquer la poignée du disjoncteur en position OFF.

Warnung Vor Ausführung der folgenden Vorgänge ist sicherzustellen, daß die Gleichstromschaltung keinen Strom erhält. Um sicherzustellen, daß sämtlicher Strom abgestellt ist, machen Sie auf der Schalttafel den Unterbrecher für die Gleichstromschaltung ausfindig, stellen Sie den Unterbrecher auf AUS, und kleben Sie den Schaltergriff des Unterbrechers mit Klebeband in der AUS-Stellung fest.

Avvertenza Prima di svolgere una qualsiasi delle procedure seguenti, verificare che il circuito CC non sia alimentato. Per verificare che tutta l'alimentazione sia scollegata (OFF), individuare l'interruttore automatico sul quadro strumenti che alimenta il circuito

CC, mettere l'interruttore in posizione OFF e fissarlo con nastro adesivo in tale posizione.

Advarsel Før noen av disse prosedyrene utføres, kontroller at strømmen er frakoblet likestrømkretsen. Sørg for at all strøm er slått AV. Dette gjøres ved å lokalisere strømbryteren på brytertavlen som betjener likestrømkretsen, slå strømbryteren AV og teipe bryterhåndtaket på strømbryteren i AV-stilling.

Aviso Antes de executar um dos seguintes procedimentos, certifique-se que desligou a fonte de alimentação de energia do circuito de corrente contínua. Para se assegurar que toda a corrente foi DESLIGADA, localize o disjuntor no painel que serve o circuito de corrente contínua e coloque-o na posição OFF (Desligado), segurando nessa posição a manivela do interruptor do disjuntor com fita isoladora.

¡Atención! Antes de proceder con los siguientes pasos, comprobar que la alimentación del circuito de corriente continua (CC) esté cortada (OFF). Para asegurarse de que toda la alimentación esté cortada (OFF), localizar el interruptor automático en el panel que alimenta al circuito de corriente continua, cambiar el interruptor automático a la posición de Apagado (OFF), y sujetar con cinta la palanca del interruptor automático en posición de Apagado (OFF).

Warning! Innan du utför någon av följande procedurer måste du kontrollera att strömförsörjningen till likströmskretsen är bruten. Kontrollera att all strömförsörjning är BRUTEN genom att slå AV det överspänningsskydd som skyddar likströmskretsen och tejsa fast överspänningsskyddets omkopplare i FRÅN-läget.

DC Power Grounding Requirements and Warning

An insulated grounding conductor that is identical in size to the grounded and ungrounded branch circuit supply conductors but is identifiable by green and yellow stripes is installed as part of the branch circuit that supplies the device. The grounding conductor is a separately derived system at the supply transformer or motor generator set.



WARNING: When you install the device, the ground connection must always be made first and disconnected last.

Waarschuwing Bij de installatie van het toestel moet de aardverbinding altijd het eerste worden gemaakt en het laatste worden losgemaakt.

Varoitus Laitetta asennettaessa on maahan yhdistäminen aina tehtävä ensiksi ja maadoituksen irti kytkeminen viimeiseksi.

Avertissement Lors de l'installation de l'appareil, la mise à la terre doit toujours être connectée en premier et déconnectée en dernier.

Warnung Der Erdanschluß muß bei der Installation der Einheit immer zuerst hergestellt und zuletzt abgetrennt werden.

Avvertenza In fase di installazione dell'unità, eseguire sempre per primo il collegamento a massa e disconnetterlo per ultimo.

Advarsel Når enheten installeres, må jordledningen alltid tilkobles først og frakobles sist.

Aviso Ao instalar a unidade, a ligação à terra deverá ser sempre a primeira a ser ligada, e a última a ser desligada.

¡Atención! Al instalar el equipo, conectar la tierra la primera y desconectarla la última.

Warning! Vid installation av enheten måste jordledningen alltid anslutas först och kopplas bort sist.

DC Power Wiring Sequence Warning



WARNING: Wire the DC power supply using the appropriate lugs. When connecting power, the proper wiring sequence is ground to ground, +RTN to +RTN, then -48 V to -48 V. When disconnecting power, the proper wiring sequence is -48 V to -48 V, +RTN to +RTN, then ground to ground. Note that the ground wire must always be connected first and disconnected last.

Waarschuwing De juiste bedradingsvolgorde verbonden is aarde naar aarde, +RTN naar +RTN, en -48 V naar -48 V. De juiste bedradingsvolgorde losgemaakt is en -48 naar -48 V, +RTN naar +RTN, aarde naar aarde.

Varoitus Oikea yhdistettävä kytkentäjäjestys on maajohto maajohtoon, +RTN varten +RTN, -48 V varten -48 V. Oikea irrotettava kytkentäjäjestys on -48 V varten -48 V, +RTN varten +RTN, maajohto maajohtoon.

Avertissement Câblez l'alimentation CC En utilisant les crochets appropriés à l'extrémité de câblage. En reliant la puissance, l'ordre approprié de câblage

est rectifié pour rectifier, +RTN à +RTN, puis -48 V à -48 V. En débranchant la puissance, l'ordre approprié de câblage est -48 V à -48 V, +RTN à +RTN, a alors rectifié pour rectifier. Notez que le fil de masse devrait toujours être relié d'abord et débranché pour la dernière fois. Notez que le fil de masse devrait toujours être relié d'abord et débranché pour la dernière fois.

Warnung Die Stromzufuhr ist nur mit geeigneten Ringösen an das DC Netzteil anzuschliessen. Die richtige Anschlusssequenz ist: Erdanschluss zu Erdanschluss, +RTN zu +RTN und dann -48V zu -48V. Die richtige Sequenz zum Abtrennen der Stromversorgung ist -48V zu -48V, +RTN zu +RTN und dann Erdanschluss zu Erdanschluss. Es ist zu beachten dass der Erdanschluss immer zuerst angeschlossen und als letztes abgetrennt wird.

Avvertenza Mostra la morsettiera dell alimentatore CC. Cablare l'alimentatore CC usando i connettori adatti all'estremità del cablaggio, come illustrato. La corretta sequenza di cablaggio è da massa a massa, da positivo a positivo (da linea ad L) e da negativo a negativo (da neutro a N). Tenere presente che il filo di massa deve sempre venire collegato per primo e scollegato per ultimo.

Advarsel Riktig tilkoples tilkoplingssekvens er jord til jord, +RTN til +RTN, -48 V til -48 V. Riktig frakoples tilkoplingssekvens er -48 V til -48 V, +RTN til +RTN, jord til jord.

Aviso Ate con alambre la fuente de potencia cc Usando los terminales apropiados en el extremo del cableado. Al conectar potencia, la secuencia apropiada del cableado se muele para moler, +RTN a +RTN, entonces -48 V a -48 V. Al desconectar potencia, la secuencia apropiada del cableado es -48 V a -48 V, +RTN a +RTN, entonces molió para moler. Observe que el alambre de tierra se debe conectar siempre primero y desconectar por último. Observe que el alambre de tierra se debe conectar siempre primero y desconectar por último.

¡Atención! Wire a fonte de alimentação de DC Usando os talões apropriados nan Extremidade da fiação. Ao conectar a potência, a seqüência apropriada da fiação é moída para moer, +RTN a +RTN, então -48 V a -48 V. Ao desconectar a potência, a seqüência apropriada da fiação é -48 V a -48 V, +RTN a +RTN, moeu então para moer. Anote que o fio à terra deve sempre ser conectado primeiramente e desconectado por último. Anote que o fio à terra deve sempre ser conectado primeiramente e desconectado por último.

Varning! Korrekt kopplingssekvens ar jord till jord, +RTN till +RTN, -48 V till -48 V. Korrekt kopplas kopplingssekvens ar -48 V till -48 V, +RTN till +RTN, jord till jord.

DC Power Wiring Terminations Warning



WARNING: When stranded wiring is required, use approved wiring terminations, such as closed-loop or spade-type with upturned lugs. These terminations must be the appropriate size for the wires and must clamp both the insulation and conductor.

Waarschuwing Wanneer geslagen bedrading vereist is, dient u bedrading te gebruiken die voorzien is van goedgekeurde aansluitpunten, zoals het gesloten-lus type of het grijperschop type waarbij de aansluitpunten omhoog wijzen. Deze aansluitpunten dienen de juiste maat voor de draden te hebben en dienen zowel de isolatie als de geleider vast te klemmen.

Varoitus Jos säikeellinen johdin on tarpeen, käytä hyväksyttyä johdinliitääntä, esimerkiksi suljettua silmukkaa tai kourumaista liitääntä, jossa on ylöspäin käännetyt kiinnityskorvat. Tällaisten liitääntöjen tulee olla kooltaan johtimiin sopivia ja niiden tulee puristaa yhteen sekä eristeen että johdinosan.

Avertissement Quand des fils torsadés sont nécessaires, utiliser des douilles terminales homologuées telles que celles à circuit fermé ou du type à plage ouverte avec cosses rebroussées. Ces douilles terminales doivent être de la taille qui convient aux fils et doivent être refermées sur la gaine isolante et sur le conducteur.

Warnung Wenn Litzenverdrahtung erforderlich ist, sind zugelassene Verdrahtungsabschlüsse, z.B. für einen geschlossenen Regelkreis oder gabelförmig, mit nach oben gerichteten Kabelschuhen zu verwenden. Diese Abschlüsse sollten die angemessene Größe für die Drähte haben und sowohl die Isolierung als auch den Leiter festklemmen.

Avvertenza Quando occorre usare trecce, usare connettori omologati, come quelli a occhio o a forcilla con linguette rivolte verso l'alto. I connettori devono avere la misura adatta per il cablaggio e devono serrare sia l'isolante che il conduttore.

Advarsel Hvis det er nødvendig med flertrådede ledninger, brukes godkjente ledningsavslutninger, som for eksempel lukket sløyfe eller spadetype med oppoverbøyde kabelsko. Disse avslutningene skal ha riktig størrelse i forhold til ledningene, og skal klemme sammen både isolasjonen og ledere.

Aviso Quando forem requeridas montagens de instalação eléctrica de cabo torcido, use terminações de cabo aprovadas, tais como, terminações de cabo em circuito fechado e planas com terminais de orelha voltados para cima. Estas terminações de cabo deverão ser do tamanho apropriado para os respectivos cabos, e deverão prender simultaneamente o isolamento e o fio condutor.

¡Atención! Cuando se necesite hilo trenzado, utilizar terminales para cables homologados, tales como las de tipo "bucle cerrado" o "espada", con las lengüetas de conexión vueltas hacia arriba. Estos terminales deberán ser del tamaño apropiado para los cables que se utilicen, y tendrán que sujetar tanto el aislante como el conductor.

Varning! När flertrådiga ledningar krävs måste godkända ledningskontakter användas, t.ex. kabelsko av slutet eller öppen typ med uppåtvänd tapp. Storleken på dessa kontakter måste vara avpassad till ledningarna och måste kunna hålla både isoleringen och ledaren fastklämda.

Multiple Power Supplies Disconnection Warning



WARNING: The network device has more than one power supply connection. All connections must be removed completely to remove power from the unit completely.

Waarschuwing Deze eenheid heeft meer dan één stroomtoevoerverbinding; alle verbindingen moeten volledig worden verwijderd om de stroom van deze eenheid volledig te verwijderen.

Varoitus Tässä laitteessa on useampia virtalähdekytkentöjä. Kaikki kytkennät on irrotettava kokonaan, jotta virta poistettaisiin täysin laitteesta.

Avertissement Cette unité est équipée de plusieurs raccordements d'alimentation. Pour supprimer tout courant électrique de l'unité, tous les cordons d'alimentation doivent être débranchés.

Warnung Diese Einheit verfügt über mehr als einen Stromanschluß; um Strom gänzlich von der Einheit fernzuhalten, müssen alle Stromzufuhren abgetrennt sein.

Avvertenza Questa unità ha più di una connessione per alimentatore elettrico; tutte le connessioni devono essere completamente rimosse per togliere l'elettricità dall'unità.

Advarsel Denne enheten har mer enn én strømtilkobling. Alle tilkoblinger må kobles helt fra for å eliminere strøm fra enheten.

Aviso Este dispositivo possui mais do que uma conexão de fonte de alimentação de energia; para poder remover a fonte de alimentação de energia, deverão ser desconectadas todas as conexões existentes.

¡Atención! Esta unidad tiene más de una conexión de suministros de alimentación; para eliminar la alimentación por completo, deben desconectarse completamente todas las conexiones.

Varning! Denna enhet har mer än en strömförsörjningsanslutning; alla anslutningar måste vara helt avlägsnade innan strömtillförseln till enheten är fullständigt bruten.

TN Power Warning



WARNING: The device is designed to work with a TN power system.

Waarschuwing Het apparaat is ontworpen om te functioneren met TN energiesystemen.

Varoitus Koje on suunniteltu toimimaan TN-sähkövoimajärjestelmien yhteydessä.

Avertissement Ce dispositif a été conçu pour fonctionner avec des systèmes d'alimentation TN.

Warnung Das Gerät ist für die Verwendung mit TN-Stromsystemen ausgelegt.

Avvertenza Il dispositivo è stato progettato per l'uso con sistemi di alimentazione TN.

Advarsel Utstyret er utfomet til bruk med TN-strømsystemer.

Aviso O dispositivo foi criado para operar com sistemas de corrente TN.

¡Atención! El equipo está diseñado para trabajar con sistemas de alimentación tipo TN.

Varning! Enheten är konstruerad för användning tillsammans med elkraftssystem av TN-typ.

Agency Approvals for EX Series Switches

IN THIS SECTION

- [Compliance Statement for Argentina | 258](#)

This topic applies to hardware devices in the EX Series product family, which includes EX Series switches, the EX Series Redundant Power System (RPS), and the XRE200 External Routing Engine.

These hardware devices comply with the following standards:

- Safety
 - CAN/CSA-C22.2 No. 60950-1 Information Technology Equipment
 - CAN/CSA-C22.2 No. 62368-1 Information Technology Equipment
 - UL 60950-1 Information Technology Equipment
 - UL 62368-1 Second Edition
 - EN 60950-1 Information Technology Equipment
 - EN 62368-1 Second Edition
 - IEC 60950-1 Information Technology Equipment
 - IEC 62368-1 Second Edition
 - EN 60825-1 Safety of Laser Products - Part 1: Equipment classification and requirements
- EMC
 - FCC 47CFR Part 15 Class A (USA)
 - EN 55022 Class A Emissions (Europe)
 - ICES-003 Class A
 - VCCI Class A (Japan)
 - AS/NZS CISPR 22 Class A (Australia/New Zealand)
 - CISPR 22 Class A

- EN 55024
- EN 300386
- EN 61000-3-2 Power Line Harmonics
- EN 61000-3-3 Voltage Fluctuations and Flicker
- EN 61000-4-2 ESD
- EN 61000-4-3 Radiated Immunity
- EN 61000-4-4 EFT
- EN 61000-4-5 Surge
- EN 61000-4-6 Low Frequency Common Immunity
- EN 61000-4-11 Voltage Dips and Sags

Compliance Statement for Argentina

EQUIPO DE USO IDÓNEO.

Compliance Statements for EMC Requirements for EX Series Switches

IN THIS SECTION

- [Canada | 259](#)
- [Taiwan | 260](#)
- [European Community | 260](#)
- [Israel | 260](#)
- [Japan | 260](#)
- [Korea | 261](#)
- [United States | 261](#)

This topic applies to hardware devices in the EX Series product family, which includes EX Series switches, the EX Series Redundant Power System (RPS), and the XRE200 External Routing Engine.

This topic describes the EMC requirements for these hardware devices.

Canada

This Class A digital apparatus complies with Canadian ICES-003.

Cet appareil numérique de la classe A est conforme à la norme NMB-003 du Canada.

The Industry Canada label identifies certified equipment. This certification means that the equipment meets certain telecommunications network protective, operational, and safety requirements. Industry Canada does not guarantee the equipment will operate to the users' satisfaction.

Before installing this equipment, users should ensure that it is permissible to connect the equipment to the facilities of the local telecommunications company. The equipment must also be installed using an acceptable method of connection. In some cases, the inside wiring associated with a single line individual service can be extended by means of a certified connector assembly. The customer should be aware that compliance with the above conditions might not prevent degradation of service in some situations.

Repairs to certified equipment should be made by an authorized Canadian maintenance facility designated by the supplier. Any repairs or alterations made by the user to this equipment, or equipment malfunctions, might give the telecommunications company cause to request the user to disconnect the equipment.



CAUTION: Users should not attempt to make electrical ground connections by themselves, but should contact the appropriate inspection authority or an electrician, as appropriate.

Users should ensure for their own protection that the electrical ground connections of the power utility, telephone lines, and internal metallic water pipe system, if present, are connected together. This precaution might be particularly important in rural areas.

Taiwan

此為甲類資訊技術設備。於一般家居環境使用時，本設備可能導致射頻干擾，用請採取相應措施。

The preceding translates as follows:

This is a Class A device. In a domestic environment, this device might cause radio interference, in which case the user needs to take adequate measures.

European Community

This is a Class A device. In a domestic environment this device might cause radio interference, in which case the user needs to take adequate measures.

Israel

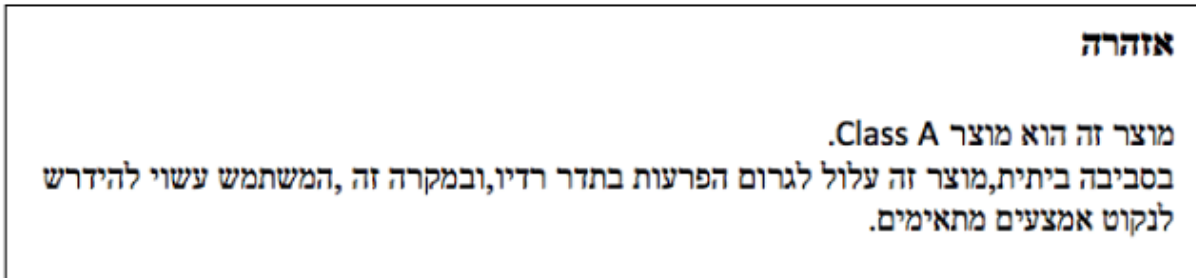

The preceding translates as follows:

Warning: This product is Class A. In residential environments, the product may cause radio interference, and in such a situation, the user may be required to take adequate measures.

Japan

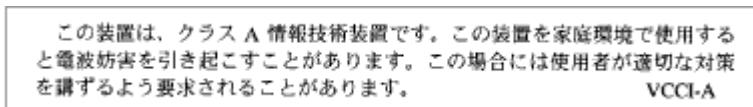

The preceding translates as follows:

This is a Class A device. In a domestic environment this device might cause radio interference, in which case the user needs to take adequate measures.

VCCI-A

Korea

이 기기는 업무용(A급) 전자파적합기기로서 판매자 또는 사용자는 이 점을 주의하시기 바라며, 가정외의 지역에서 사용하는 것을 목적으로 합니다.

Korean Class A Warning

g040913

The preceding translates as follows:

This equipment is Industrial (Class A) electromagnetic wave suitability equipment and seller or user should take notice of it, and this equipment is to be used in the places except for home

United States

The device has been tested and found to comply with the limits for a Class A digital device, pursuant to Part 15 of the FCC Rules. These limits are designed to provide reasonable protection against harmful interference when the equipment is operated in a commercial environment. This equipment generates, uses, and can radiate radio frequency energy and, if not installed and used in accordance with the instruction manual, might cause harmful interference to radio communications. Operation of this equipment in a residential area is likely to cause harmful interference, in which case users need to correct the interference at their own expense.

FCC Part 15 Statement

This equipment has been tested and found to comply with the limits for a Class A digital device pursuant to Part 15 of the FCC Rules. These limits are designed to provide reasonable protection against harmful interference in a residential installation. This equipment generates, uses, and can radiate radio frequency

energy and, if not installed and used in accordance with the instructions, might cause harmful interference to radio communications. However, there is no guarantee that interference will not occur in a particular installation.

If this equipment does cause harmful interference to radio or television reception, which can be determined by turning the equipment off and on, the user is encouraged to try and correct the interference by one or more of the following measures:

- Reorient or relocate the receiving antenna.
- Increase the separation between the equipment and the receiver.
- Connect the equipment into an outlet on a circuit different from that to which the receiver is connected.
- Consult the dealer or an experienced radio or TV technician for help.

Compliance Statements for Acoustic Noise for EX Series Switches

This topic applies to hardware devices in the EX Series product family, which includes EX Series switches, the EX Series Redundant Power System (RPS), and the XRE200 External Routing Engine.

Maschinenlärminformations-Verordnung - 3. GPSGV, der höchste Schalldruckpegel beträgt 70 dB(A) oder weniger gemäss EN ISO 7779

Translation: The emitted sound pressure is below 70 dB(A) per EN ISO 7779.

Statements of Volatility for Juniper Network Devices

A *statement of volatility (SoV)*—sometimes known as *letter of volatility (LoV)*—identifies the volatile and non-volatile storage components in Juniper Networks devices, and describes how to remove non-volatile storage components from the device.

NOTE: Individual FRUs do not have separate SoV or LoV documents. They are covered in the SoV or LoV of the Juniper Networks device in which they are installed.

NOTE: Statements of volatility are not available for all Juniper Networks devices.

CTP Series:

- [CTP150](#)
- [CTP2000](#)

EX Series:

- [EX2200](#) and [EX2200-C](#)
- [EX2300-24P](#), [EX2300-24T](#), and [EX2300-24T-DC](#)
- [EX2300-48P](#) and [EX2300-48T](#)
- [EX2300-C](#)
- [EX3300](#)
- [EX3400-24P](#), [EX3400-24T](#), [EX3400-24T-DC](#)
- [EX3400-48P](#), [EX3400-48T](#), [EX3400-48T-AFI](#)
- [EX4200](#)
- [EX4300](#)
- [EX4300-48MP](#)
- [EX4400](#)
 1. [EX4400-24T](#)
 2. [EX4400-24P](#)
 3. [EX4400-24MP](#)
 4. [EX4400-48T](#)
 5. [EX4400-48P](#)

6. EX4400-48MP

7. EX4400-48F

- EX4500
- EX4550
- EX4600
- EX8200
- EX9251
- EX9253
- XRE200 External Routing Engine

LN Series:

- LN1000-CC

MX Series:

- M7i
- M7i Compact Forwarding Engine Board (CFEB)
- M40e and M10i
- M320
- MX5, MX10, MX40, and MX80
- MX104
- MX204
- MX304
- MX240, MX480, and MX960
- MX10003
- RE-A-2000 Route Engine
- RE-S-X6-64G Routing Engine

NFX Series:

- NFX250

QFX Series:

- [QFX3008-I](#)
- [QFX3100](#)
- [QFX3500](#)
- [QFX3600](#)
- [QFX5100-24Q](#)
- [QFX5100-48S](#)
- [QFX5100-48T](#)
- [QFX5110-32Q](#)
- [QFX5110-48S](#)
- [QFX5120](#)
 1. [QFX5120-32C](#)
 2. [QFX5120-48T](#)
 3. [QFX5120-48Y](#)
 4. [QFX5120-48YM](#)
- [QFX5200](#)
- [QFX5200-32C](#)
- [QFX10008](#) and [QFX10016](#)

SRX Series:

- [SRX100](#)
- [SRX110](#)
- [SRX210B](#)
- [SRX210H-POE](#)
- [SRX210H-P-MGW](#)
- [SRX220](#)
- [SRX240H](#)

- SRX240H-POE
- SRX300
- SRX320
- SRX340 and SRX345
- SRX380
- SRX550
- SRX650
- SRX1400
- SRX1500
- SRX3400 and SRX3600
- SRX4200
- SRX4600
- SRX5400, SRX5600, and SRX5800
- SRX-MP-1SERIAL
- SSG-520M

T Series:

- RE-A-2000 Route Engine