

EX9208 Switch Hardware Guide

Published
2024-07-10

Juniper Networks, Inc.
1133 Innovation Way
Sunnyvale, California 94089
USA
408-745-2000
www.juniper.net

Juniper Networks, the Juniper Networks logo, Juniper, and Junos are registered trademarks of Juniper Networks, Inc. in the United States and other countries. All other trademarks, service marks, registered marks, or registered service marks are the property of their respective owners.

Juniper Networks assumes no responsibility for any inaccuracies in this document. Juniper Networks reserves the right to change, modify, transfer, or otherwise revise this publication without notice.

EX9208 Switch Hardware Guide

Copyright © 2024 Juniper Networks, Inc. All rights reserved.

The information in this document is current as of the date on the title page.

YEAR 2000 NOTICE

Juniper Networks hardware and software products are Year 2000 compliant. Junos OS has no known time-related limitations through the year 2038. However, the NTP application is known to have some difficulty in the year 2036.

END USER LICENSE AGREEMENT

The Juniper Networks product that is the subject of this technical documentation consists of (or is intended for use with) Juniper Networks software. Use of such software is subject to the terms and conditions of the End User License Agreement ("EULA") posted at <https://support.juniper.net/support/eula/>. By downloading, installing or using such software, you agree to the terms and conditions of that EULA.

Table of Contents

About This Guide | xii

1

Fast Track: Initial Installation

Fast Track to Rack Installation and Power | 2

Installing the EX9208 Switch in a Rack | 2

Connect to Power | 7

Claim, Onboard, and Configure EX9208 | 12

2

Overview

EX9208 System Overview | 15

EX9208 Switch Hardware Overview | 15

EX9208 Switch Configurations | 21

EX9208 Switch Hardware and CLI Terminology Mapping | 27

Chassis Physical Specifications of an EX9208 Switch | 32

Field-Replaceable Units in an EX9200 Switch | 36

EX9208 Chassis | 38

Understanding EX9208 Switch Component and Functionality Redundancy | 39

Craft Interface in an EX9200 Switch | 40

Midplane in an EX9200 Switch | 47

Cable Management Brackets in an EX9208 Switch | 49

EX9208 Cooling System | 51

EX9208 Power System | 53

AC Power Supply in an EX9208 Switch | 54

AC Power Supply Specifications for EX9208 Switches | 56

AC Power Cord Specifications for an EX9208 Switch | 57

AC Power Supply LEDs in an EX9208 Switch | 60

- DC Power Supply in an EX9208 Switch | **61**
- DC Power Supply Specifications for EX9208 Switches | **63**
- DC Power Supply LEDs in an EX9208 Switch | **65**
- Power Requirements for EX9200 Switch Components | **66**

EX9200 Host Subsystem | 67

- Host Subsystem in an EX9200 Switch | **68**
- Routing Engine Module in an EX9200 Switch | **69**
- Routing Engine Module LEDs in an EX9200 Switch | **73**
- Switch Fabric Module in an EX9200 Switch | **75**
- Switch Fabric Module LEDs in an EX9200 Switch | **78**
- EX9200-SF3 Module in an EX9200 Switch | **79**

EX9200 Line Cards | 87

- Line Card Model and Version Compatibility in an EX9200 Switch | **88**
- EX9200-2C-8XS Line Card | **91**
- EX9200-4QS Line Card | **93**
- EX9200-6QS Line Card | **94**
- EX9200-MPC Line Card | **97**
- EX9200-12QS Line Card | **101**
- EX9200-15C Line Card | **103**
- EX9200-32XS Line Card | **107**
- EX9200-40T Line Card | **108**
- EX9200-40F Line Card | **110**
- EX9200-40F-M Line Card | **112**
- EX9200-40XS Line Card | **114**
- Line Card LED in an EX9200 Switch | **115**
- Network Port LEDs on Line Cards in an EX9200 Switch | **116**

Modular Interface Card LED in an EX9200 Switch | 118

Configuring Rate Selectability on an EX9200-12QS Line Card to Enable Different Port Speeds | 118

Configuring Rate Selectability at the PIC Level | 119

Configuring Rate Selectability at the Port Level | 121

3

Site Planning, Preparation, and Specifications

Site Preparation Checklist for an EX9208 Switch | 125

EX9208 Site Guidelines and Requirements | 127

Environmental Requirements and Specifications for EX Series Switches | 127

General Site Guidelines | 134

Site Electrical Wiring Guidelines | 135

Clearance Requirements for Airflow and Hardware Maintenance for an EX9208 Switch | 136

Rack Requirements | 137

Cabinet Requirements | 139

Power Requirements for EX9200 Switch Components | 140

Grounding Cable and Lug Specifications for EX9200 Switches | 142

EX9200 Network Cable and Transceiver Planning | 144

Pluggable Transceivers Supported on EX9200 Switches | 145

Overview of EX Series Switches: Fiber-Optic Cable Signal Loss, Attenuation, and Dispersion | 146

Calculate the Fiber-Optic Cable Power Budget for EX Series Devices | 147

Calculating the Fiber-Optic Cable Power Margin for EX Series Devices | 148

EX9200 Management Cable Specifications and Pinouts | 150

Management Cable Specifications | 150

Console Port Connector Pinout Information | 151

USB Port Specifications for an EX Series Switch | 152

RJ-45 Management Port Connector Pinout Information | 153

RJ-45 to DB-9 Serial Port Adapter Pinout Information | 154

4

Initial Installation and Configuration

Unpacking and Mounting the EX9208 Switch | 156

- Unpacking the EX9200 Switch | 156
- Unpacking a Line Card Used in an EX9200 Switch | 158
- Parts Inventory (Packing List) for an EX9208 Switch | 159
- Register Products—Mandatory to Validate SLAs | 162
- Installing and Connecting an EX9208 Switch | 162
- Installing a Mounting Shelf in a Rack or Cabinet for an EX9208 Switch | 163
- Moving the Mounting Brackets for Center-Mounting an EX9200 Switch | 165
- Mounting an EX9200 Switch on a Rack or Cabinet Using a Mechanical Lift | 167
- Mounting an EX9208 Switch on a Rack or Cabinet Without Using a Mechanical Lift | 170

Connecting the EX9208 to Power | 173

- Connect Earth Ground to an EX Series Switch | 173
- Connecting AC Power to an EX9208 Switch | 184
- Powering On an AC-Powered EX9200 Switch | 186
- Connecting DC Power to an EX9208 Switch | 187
- Powering On a DC-Powered EX9200 Switch | 192

Connecting the EX9200 to External Devices | 194

- Connecting an EX9200 Switch to a Network for Out-of-Band Management | 195
- Connecting an EX9200 Switch to a Management Console or an Auxiliary Device | 196
- Connecting the EX9200 Switch to an External Alarm-Reporting Device | 197

Connecting the EX9200 to the Network | 198

- Install a Transceiver | 198
- Connect a Fiber-Optic Cable | 202

Configuring Junos OS on the EX9200 | 203

- EX9200 Switch Default Configuration | 203
- Connecting and Configuring an EX9200 Switch (CLI Procedure) | 204

Maintaining Components

Routine Maintenance Procedures for EX9200 Switches | 210

Maintaining the EX9200 Cooling System | 210

Removing a Fan Tray from an EX9200 Switch | 211

Installing a Fan Tray in an EX9200 Switch | 213

Maintaining the Fan Tray in EX9200 Switches | 217

Maintaining the Air Filter in EX9200 Switches | 219

Maintaining the EX9208 Power System | 220

Removing an AC Power Supply from an EX9208 Switch | 221

Installing an AC Power Supply in an EX9208 Switch | 222

Removing a DC Power Supply from an EX9208 Switch | 224

Installing a DC Power Supply in an EX9208 Switch | 226

Maintaining Power Supplies in EX9200 Switches | 228

Maintaining the EX9200 Host Subsystem | 230

Taking the Host Subsystem Offline in an EX9200 Switch | 230

Removing an RE Module from an EX9200 Switch | 231

Installing an RE Module in an EX9200 Switch | 233

Upgrading an EX9200-SF to an EX9200-SF2 | 235

Preparing the EX9200 Switch for an EX9200-SF2 Upgrade | 235

Powering Off the Switch | 236

Removing a Routing Engine from an EX9200-SF Module | 236

Replacing the EX9200-SF with the EX9200-SF2 | 236

Installing a Routing Engine into an EX9200-SF2 | 236

Powering On the Switch | 237

Completing the EX9200-SF2 Upgrade | 237

Upgrading to an EX9200-SF3 | 238

Preparing the EX9200 Switch for an EX9200-SF3 Upgrade | 239

Powering Off the Switch | 239

Removing a Routing Engine from an SF Module | 239

Replacing the EX9200-SF or EX9200-SF2 with the EX9200-SF3 | 240

Installing a Routing Engine into an EX9200-SF3 | 240

Powering On the Switch | 240

Completing the EX9200-SF3 Upgrade | 240

Removing an SF Module from an EX9200 Switch | 242

Installing an SF Module in an EX9200 Switch | 243

Maintaining the Host Subsystem in EX9200 Switches | 247

Maintaining the EX9200 Line Cards | 251

Handling and Storing Line Cards | 252

Holding a Line Card | 252

Storing a Line Card | 254

Maintaining Line Card Cables | 255

Unpacking a Line Card Used in an EX9200 Switch | 255

Removing a Line Card from an EX9200 Switch | 256

Installing a Line Card in an EX9200 Switch | 259

Removing a MIC from an EX9200-MPC Line Card | 261

Installing a MIC in an EX9200-MPC Line Card | 264

Maintain Transceivers | 269

Remove a Transceiver | 270

Install a Transceiver | 272

Maintaining Alarm Relay Wire | 276

Disconnecting the Alarm Relay Wires from the Craft Interface in an EX9200 Switch | 276

Connecting the Alarm Relay Wires to the Craft Interface in an EX9200 Switch | 277

Maintain Fiber-Optic Cables | 278

Connect a Fiber-Optic Cable | 278

Disconnect a Fiber-Optic Cable | 279

How to Handle Fiber-Optic Cables | 280

Maintaining the EX9208 Cable Management Brackets | 281

Installing Cable Management Brackets on an EX9208 Switch | 281

Removing Cable Management Brackets from an EX9208 Switch | 283

Removing an EX9208 from a Rack or Cabinet | 283

Powering Off an EX9200 Switch | 283

Removing an EX9200 Switch from a Rack or Cabinet Using a Mechanical Lift | 284

Removing an EX9208 Switch from a Rack or Cabinet Without Using a Mechanical Lift | 285

6

Troubleshooting Hardware

Troubleshooting EX9200 Components | 289

Troubleshooting the Cooling System in an EX9200 Switch | 289

Troubleshooting Power Supplies in an EX9200 Switch | 290

Troubleshooting Line Cards in EX9200 Switches | 292

Troubleshooting Traffic Drops on EX9200-6QS Line Cards | 295

Understand Alarm Types and Severity Levels on EX Series Switches | 296

Chassis Component Alarm Conditions on EX9200 Switches | 298

Monitor System Log Messages | 306

Troubleshoot Temperature Alarms in EX Series Switches | 313

7

Contacting Customer Support and Returning the Chassis or Components

Returning an EX9208 Chassis or Components | 321

Returning an EX9200 Switch or Component for Repair or Replacement | 321

Locating the Serial Number on an EX9208 Switch or Component | 322

Listing the Switch and Components Details with the CLI | 322

Locating the Serial Number ID Label on an EX9200 Switch Chassis | 325

Locating Serial Number ID Labels on FRU Components | 326

Contact Customer Support to Obtain a Return Material Authorization | 329

Packing an EX9200 Switch or Component | 330

Packing an EX9200 Switch | 331

Packing EX9200 Switch Components for Shipping | 332

8

Safety and Compliance Information

General Safety Guidelines and Warnings	335
Definitions of Safety Warning Levels	336
Qualified Personnel Warning	338
Warning Statement for Norway and Sweden	338
Fire Safety Requirements	339
Installation Instructions Warning	340
Chassis and Component Lifting Guidelines	341
Restricted Access Warning	341
Ramp Warning	343
Rack-Mounting and Cabinet-Mounting Warnings	343
Grounded Equipment Warning	347
Radiation from Open Port Apertures Warning	348
Laser and LED Safety Guidelines and Warnings	349
Maintenance and Operational Safety Guidelines and Warnings	352
General Electrical Safety Guidelines and Warnings	358
Action to Take After an Electrical Accident	359
Prevention of Electrostatic Discharge Damage	360
AC Power Electrical Safety Guidelines	361
AC Power Disconnection Warning	362
DC Power Electrical Safety Guidelines	363
DC Power Disconnection Warning	364
DC Power Grounding Requirements and Warning	366
DC Power Wiring Sequence Warning	366
DC Power Wiring Terminations Warning	368
Multiple Power Supplies Disconnection Warning	369

TN Power Warning | 370

Agency Approvals for EX Series Switches | 371

Battery Compliance Statement for Environmental Requirements for EX Series Switches | 372

Compliance Statements for EMC Requirements for EX Series Switches | 373

Compliance Statements for Acoustic Noise for EX Series Switches | 377

About This Guide

Use this guide to install hardware and perform initial software configuration, routine maintenance, and troubleshooting for the EX9208 switch. After completing the installation and basic configuration procedures covered in this guide, refer to the Junos OS documentation for information about further software configuration.

RELATED DOCUMENTATION

| [EX9208 Switch Quick Start](#)

1

CHAPTER

Fast Track: Initial Installation

Fast Track to Rack Installation and Power | 2

Claim, Onboard, and Configure EX9208 | 12

Fast Track to Rack Installation and Power

SUMMARY

This procedure guides you through the simplest steps for the most common installation to get your EX9208 switch in a rack and connect it to power.

Have more complex installation needs? See [Installing and Connecting an EX9208 Switch](#)

IN THIS SECTION

- [Installing the EX9208 Switch in a Rack | 2](#)
- [Connect to Power | 7](#)

Installing the EX9208 Switch in a Rack

IN THIS SECTION

- [Mounting an EX9208 Switch on a Rack or Cabinet Using a Mechanical Lift | 2](#)
- [Mounting an EX9208 Switch on a Rack or Cabinet Without Using a Mechanical Lift | 5](#)

Before beginning installation of the EX9208 switch in a rack or cabinet, follow instructions in [Unpacking the EX9200 Switch](#).

You can mount the switch in a rack or cabinet using a mechanical lift or without using a mechanical lift.

Mounting an EX9208 Switch on a Rack or Cabinet Using a Mechanical Lift

Before you install the switch:

- Prepare the site for installation as described in [Site Preparation Checklist for an EX9208 Switch](#).
- Ensure the site has adequate clearance for both airflow and hardware maintenance as described in [Clearance Requirements for Airflow and Hardware Maintenance for an EX9208 Switch](#).
- Ensure you understand how to prevent electrostatic discharge (ESD) damage. See [Prevention of Electrostatic Discharge Damage](#).
- Unpack the switch as described in [Unpacking the EX9200 Switch](#).

- In a four-post rack or open-frame rack, install the mounting shelf. See [Installing a Mounting Shelf in a Rack or Cabinet for an EX9208 Switch](#).
- Review chassis lifting guidelines described in [Chassis Lifting Guidelines for EX9200 Switches](#).

Ensure that you have the following parts and tools available to install the switch:

- A mechanical lift
- 7/16-in. (11-mm) nut driver
- Phillips (+) screwdrivers, number 1 and 2
- ESD grounding wrist strap

Because of the size and weight of the switch, we strongly recommend using a mechanical lift to install the switch.



CAUTION: Do not install line cards in the chassis until after you mount the chassis securely on a rack or cabinet.



CAUTION: Before front-mounting the switch on a rack or cabinet, have a qualified technician verify that the rack or cabinet is strong enough to support the weight of the switch and is adequately supported at the installation site.



CAUTION: If you are installing more than one switch in a rack or cabinet, install the first switch at the bottom of the rack.

To install the switch using a mechanical lift:

1. Attach the ESD grounding strap to your bare wrist and connect the strap to the ESD point on the chassis.
2. Ensure that the rack or cabinet is placed in its permanent location and is secured to the building. Ensure that the installation site allows adequate clearance for both airflow and maintenance.
3. Load the switch onto the lift, making sure it rests securely on the lift platform.
4. Using the lift, position the switch in front of the rack or cabinet, centering it in front of the mounting shelf installed in the rack.
5. Lift the chassis approximately 0.75 in. (1.9 cm) above the surface of the mounting shelf and position it as close as possible to the shelf.

6. Carefully slide the switch onto the mounting shelf so that the bottom of the chassis and the mounting shelf overlap by approximately two inches.
7. Slide the switch onto the mounting shelf until the mounting brackets contact the rack rails. The shelf ensures that the holes in the mounting brackets of the chassis align with the holes in the rack rails.
8. Move the lift away from the rack.
9. Install a mounting screw into each of the open front-mounting holes aligned with the rack, starting from the bottom.
10. Visually inspect the alignment of the switch. If the switch is installed properly in the rack, all the mounting screws on one side of the rack are aligned with the mounting screws on the opposite side and the switch is level.
11. The following [Figure 1 on page 5](#) shows installing an EX9208 switch in an open-frame rack. The procedure is the same for all EX9200 switches.

Figure 1: Installing the Switch in an Open-Frame Rack

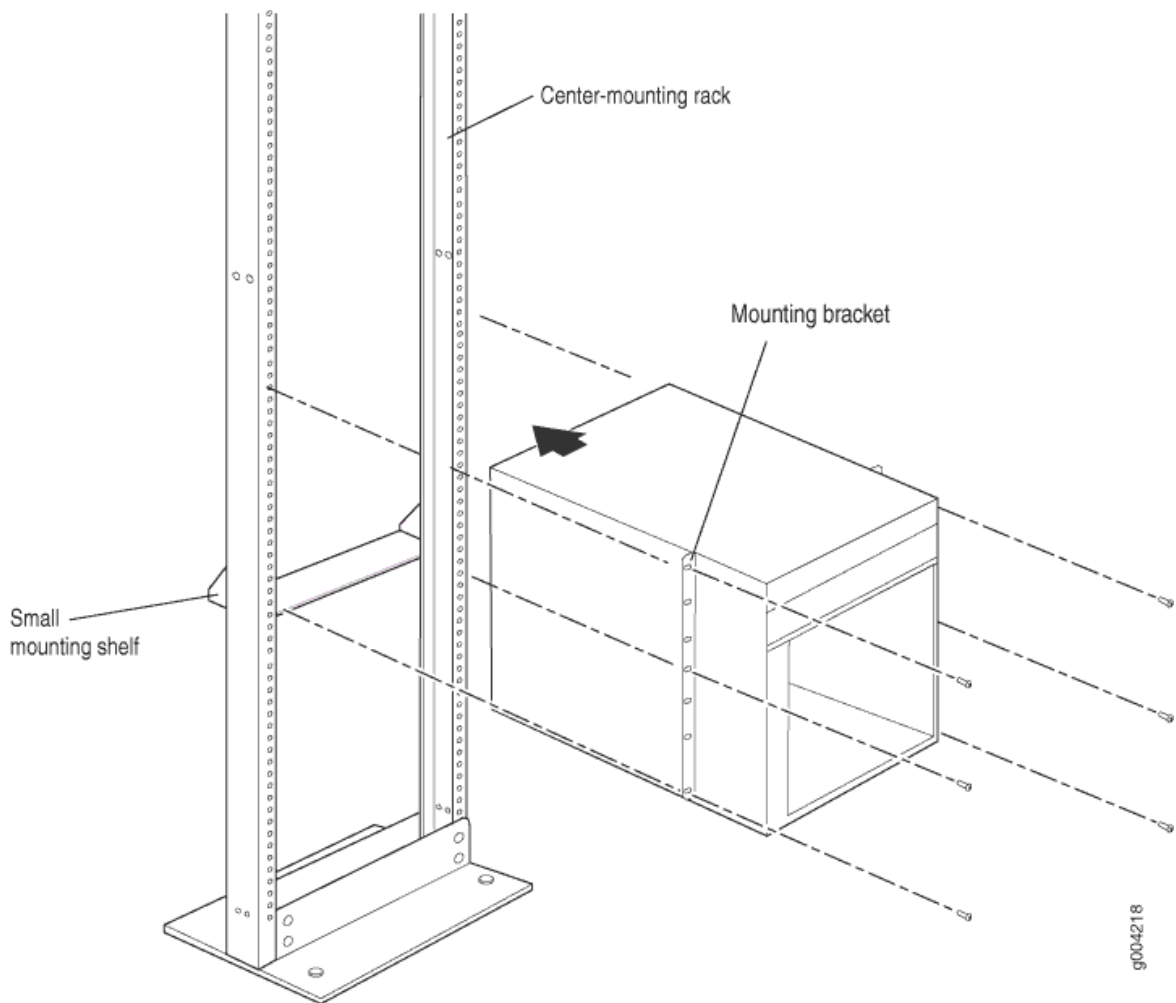

Mounting an EX9208 Switch on a Rack or Cabinet Without Using a Mechanical Lift

Before you install the switch:

- Prepare the site for installation as described in [Site Preparation Checklist for an EX9208 Switch](#).
- Ensure the site has adequate clearance for both airflow and hardware maintenance as described in [Clearance Requirements for Airflow and Hardware Maintenance for an EX9208 Switch](#).
- Unpack the switch as described in [Unpacking the EX9200 Switch](#).



CAUTION: If you are installing more than one switch in a rack, install the lowest one first. Installing a switch in an upper position in a rack or cabinet requires a lift



CAUTION: Before front mounting the switch in a rack, have a qualified technician verify that the rack is strong enough to support the weight of the switch and is adequately supported at the installation site.

NOTE: Lifting the chassis and mounting it in a rack requires two people. The empty chassis weighs approximately 65.5 lb (29.7 kg).

To mount an EX9208 Switch on a rack or cabinet without using a mechanical lift.

1. Remove all components except the midplane from the chassis. See:
 - [Removing an SF Module from an EX9200 Switch.](#)
 - [Removing an AC Power Supply from an EX9208 Switch.](#)
 - [Removing a DC Power Supply from an EX9208 Switch.](#)
 - [Removing a Fan Tray from an EX9200 Switch.](#)
2. Ensure that the rack is in its permanent location and is secured to the building. Ensure that the installation site allows adequate clearance for both airflow and maintenance.
3. Position the switch in front of the rack or cabinet, centering it in front of the mounting shelf. Use a pallet jack if one is available.
4. With one person on each side, hold onto the bottom of the chassis and carefully lift it onto the mounting shelf.



WARNING: To prevent injury, keep your back straight and lift with your legs, not your back. Avoid twisting your body as you lift. Balance the load evenly, and be sure that your footing is solid.

5. Slide the switch onto the mounting shelf until the mounting brackets contact the rack rails. The shelf ensures that the holes in the mounting brackets of the chassis align with the holes in the rack rails.
6. Install a mounting screw into each of the open mounting holes aligned with the rack, starting from the bottom.
7. Visually inspect the alignment of the switch. If the switch is installed properly in the rack, all the mounting screws on one side of the rack must be aligned with the mounting screws on the opposite side and the switch must be level. See the following [Figure 2 on page 7](#).

Figure 2: Installing the Switch in an Open-Frame Rack

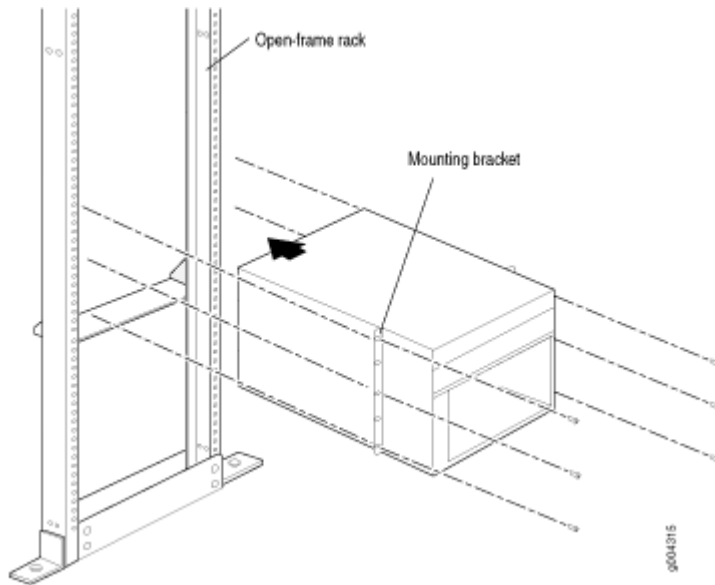

8. After you install the mounting screws and securely bolt the chassis to the rack, reinstall the components in the chassis. See:

- [Installing an SF Module in an EX9200 Switch.](#)
- [Installing a Fan Tray in an EX9200 Switch.](#)
- [Installing an AC Power Supply in an EX9208 Switch.](#)
- [Installing a DC Power Supply in an EX9208 Switch.](#)

Connect to Power

IN THIS SECTION

- [Ground the EX9208 Switch | 7](#)
- [Connect the EX9208 Switch to Power | 8](#)

Ground the EX9208 Switch

To connect earth ground to an EX9208 series switch:

1. Verify that a licensed electrician has attached the cable lug to the grounding cable.
2. Connect one end of the grounding cable to a proper earth ground, such as the rack in which the switch is mounted.
3. Attach an ESD grounding strap to your bare wrist, and connect the strap to the ESD grounding point on the switch.
4. Place the grounding lug attached to the grounding cable over the protective earthing terminal, see [Figure 3 on page 8](#).

Figure 3: Connecting a Grounding Cable to an EX Series Switch

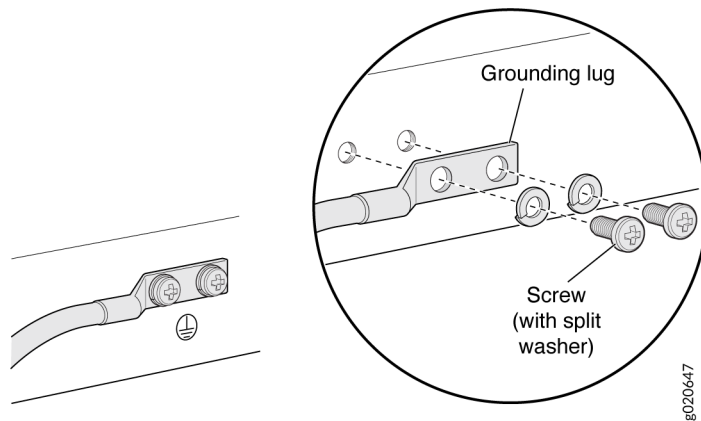

5. Secure the grounding lug to the protective earthing terminal with the washers and screws.
6. Dress the grounding cable and ensure that it does not touch or block access to other switch components and that it does not drape where people could trip over it.

Connect the EX9208 Switch to Power

Depending on the requirements as appropriate for your site, connect AC or DC power to the EX9208 switch. The following section instructs you how to connect the switch to an AC power source. Read [Connecting DC Power to an EX9208 Switch](#) to read on how to connect DC power to the EX9208 switch.

Connecting AC Power to an EX9208 Switch

Before you begin to connect power to the switch:

- Ensure you understand how to prevent electrostatic discharge (ESD) damage. See [Prevention of Electrostatic Discharge Damage](#).
- Ensure that you have connected the device chassis to earth ground.



CAUTION: For installations that require a separate grounding conductor to the chassis, have a licensed electrician complete this connection before you connect the switch to power. For instructions on connecting earth ground, see [Connect Earth Ground to an EX Series Switch](#).

- Install power supplies in the switch. See [Installing an AC Power Supply in an EX9208 Switch](#).

Ensure that you have the following parts and tools available to connect power to the switch:

- ESD grounding strap (provided)
- Power cords appropriate for your geographical location (not provided)

EX9208 switches can be configured with up to four AC power supplies.



CAUTION: Do not mix AC and DC power supplies in the same chassis.

NOTE: Each power supply must be connected to a dedicated AC power source outlet.



WARNING: Ensure that the power cords do not block access to switch components or drape where people can trip on them.

To connect AC power to an EX9208 switch:

1. Attach the ESD grounding strap to your bare wrist, and connect the strap to the ESD point on the chassis.
2. Ensure that the power supply is fully inserted and latched securely in the chassis. See [Installing an AC Power Supply in an EX9208 Switch](#).
3. If needed, move the AC input switch next to the appliance inlet on the power supply faceplate, to the off (O) position.
4. Insert the coupler end of the power cord into the AC appliance inlet on the AC power supply faceplate.

5. If the AC power source outlet has a power switch, set it to the off (O) position.
6. Insert the power cord plug into an AC power source outlet.
7. If the AC power source outlet has a power switch, set it to the on (I) position.
8. Move the AC input switch next to the appliance inlet on the power supply to the on (I) position and observe the status LEDs on the power supply faceplate. If the power supply is correctly installed and functioning normally, the AC OK and DC OK LEDs glow steady green, and the PS FAIL LED is not lit.
9. Repeat steps 2 through 9 for the remaining power supplies.

Figure 4: Connecting the Power Supply Cord to an EX9208 Switch

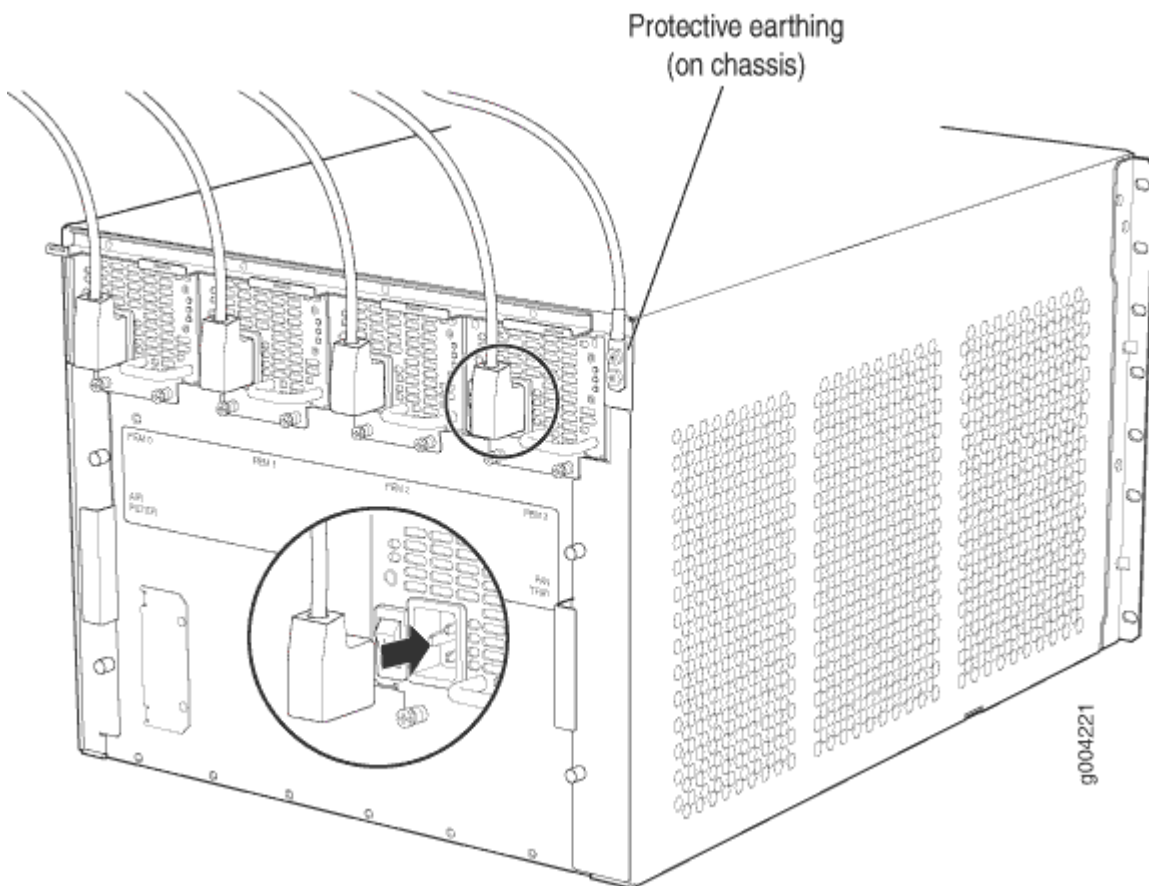

Powering on the Switch

Before you power on the switch, ensure that:

- You have installed all required switch components.

- You have installed the required number of power supplies to support redundant operation for the switch configuration.
- You understand how to protect the switch from electrostatic discharge (ESD) damage. See [Prevention of Electrostatic Discharge Damage](#).

Ensure that you have the following parts and tools available:

- An ESD wrist strap
- An external management device such as a PC
- A cable to connect the external management device to the CONSOLE port or the Ethernet management <...> port on the primary Routing Engine module (RE module).
- For connecting a management device to the console port, see [Connecting an EX9200 Switch to a Management Console or an Auxiliary Device](#). For connecting a management device to the Ethernet management port, see [Connecting an EX9200 Switch to a Network for Out-of-Band Management](#).

To power on the switch:

1. Wrap and fasten one end of the ESD wrist strap around your bare wrist, and connect the other end of the strap to the ESD point on the switch.
2. Connect the external management device to the Ethernet management (<...>) port on the primary RE module.
3. Turn on the power to the external management device.
4. Ensure that the power supplies are fully inserted in the chassis and that each of their handles is flush against the faceplate.
5. Ensure that the source power cord is inserted securely into the appliance inlet for each AC power supply.
6. Switch on the dedicated customer site circuit breakers for the power supplies. Follow the ESD and safety instructions for your site.
7. Flip the AC input switch on the power supply to the On (I) position. Observe the power supply faceplate LEDs. If the power supply is installed correctly and functioning normally, the AC OK and DC OK LEDs glow steady green. The PS FAIL LED does not glow.
8. Repeat Step 7 for the remaining power supplies installed in the switch.

If any of the status LEDs indicates that the power supply is not functioning normally, repeat the installation and cabling procedures. See [Connecting AC Power to an EX9208 Switch](#).

9. On the external management device, monitor the startup process to ensure that the system boots properly.

NOTE: After you power on a power supply, wait for at least 60 seconds before you turn it off. After you power off a power supply, wait for at least 60 seconds before you turn it back on. If the system is completely powered off when you switch on a power supply, the RE module boots as the power supply completes its startup sequence. If the Routing Engine finishes booting and you need to power off the system again, first issue the CLI request `system halt` command.

After you power on a power supply, it can take up to 60 seconds for status indicators such as power supply LEDs and the `show chassis operational mode` CLI command display to indicate that the power supply is functioning normally. Ignore any error indicators that might appear during the first 60 seconds.

Claim, Onboard, and Configure EX9208

SUMMARY

This topic provides you the pointers to onboard and configure EX9208 switches using Mist, or configure EX9208 switches using Junos CLI.

EX9208 switch is a cloud-ready switch, and you can manage this switch using [Mist AI cloud portal](#). If you have a Mist Wired Assurance license, you can follow a few simple steps to get an EX9208 up and running in the Juniper Mist AI cloud portal. See [Table 1 on page 12](#) for more information.

Table 1: Onboard and Configure EX9208 Using Mist

If you want to	Then
Claim and Onboard to Mist	See Cloud-Ready EX and QFX Switches with Mist
Configure Wired Assurance	See Juniper Mist Wired Configuration Guide
See all documentation available for Wired Assurance	Visit Wired Assurance Documentation

If you do not have a Mist Wired Assurance license, you can configure EX9208 using Junos CLI. See [Table 2 on page 13](#) for more information.

Table 2: Configure EX9208 Using Junos CLI

If you want to	Then
Customize basic configuration	See Configure Junos OS on the EX9208
Explore the software features supported on EX9208	See Feature Explorer
Configure Junos features on EX9208	See User Guides

2

CHAPTER

Overview

EX9208 System Overview | 15

EX9208 Chassis | 38

EX9208 Cooling System | 51

EX9208 Power System | 53

EX9200 Host Subsystem | 67

EX9200 Line Cards | 87

EX9208 System Overview

IN THIS SECTION

- [EX9208 Switch Hardware Overview | 15](#)
- [EX9208 Switch Configurations | 21](#)
- [EX9208 Switch Hardware and CLI Terminology Mapping | 27](#)
- [Chassis Physical Specifications of an EX9208 Switch | 32](#)
- [Field-Replaceable Units in an EX9200 Switch | 36](#)

EX9208 Switch Hardware Overview

IN THIS SECTION

- [Benefits | 16](#)
- [Software | 16](#)
- [Chassis Physical Specifications | 16](#)
- [Host Subsystem | 18](#)
- [Line Cards | 18](#)
- [Cooling System | 20](#)
- [Power Supplies | 20](#)

Juniper Networks EX9208 Ethernet Switches provide high performance, scalable connectivity, and carrier-class reliability for high-density environments such as campus-aggregation and data-center networks. The EX9208 switch has a throughput of up to 4.8 terabits per second (Tbps) or up to 240 gigabits per second (Gbps) per slot full duplex. The EX9208 switch is a modular system that provides high availability and redundancy for all major hardware components, including Routing Engine modules (RE modules), Switch Fabric modules (SF modules), fan tray (redundant fans), and power supplies.

You can manage EX9208 switches by using the same interfaces that you use for managing other devices running the Juniper Networks Junos operating system (Junos OS)—the CLI, the Network and Security Manager (NSM), and Junos Space.

Benefits

Simplified network architecture—EX9208 switches deliver a simple, secure, virtualized network environment that increases business agility. They are ideal for simplifying campus, data center, and combined campus and data center network environments by collapsing network layers. In a multichassis link aggregation (MC-LAG) configuration in the campus, you can use EX9208 switches to eliminate Spanning Tree Protocol (STP); they collapse the core and aggregation layers, thereby simplifying the network architecture and network operations. In a data center, you can use EX9208 switches to collapse core and aggregation layers. In combined campus and data center environments, EX9208 switches consolidate network layers to simplify the network architecture and operations.

MACsec support—EX9200-40F-M and EX9200-40XS line cards and EX9200-20F-MIC for EX9200-MPC line card supports IEEE 802.1AE MACsec with AES-256 bit encryption, ensuring link-layer data confidentiality, data integrity, and data origin authentication.

Software

Juniper Networks EX Series Ethernet Switches run Junos OS, which provides Layer 2 and Layer 3 switching, routing, and security services.

Chassis Physical Specifications

The EX9208 switch is eight rack units (8 U) in size. Five EX9208 switches can fit in a standard 48 U rack. Each EX9208 switch is designed to optimize rack space and cabling. See [Figure 5 on page 17](#), [Figure 6 on page 17](#), and [Figure 7 on page 18](#).

Figure 5: Front View of an EX9208 Switch

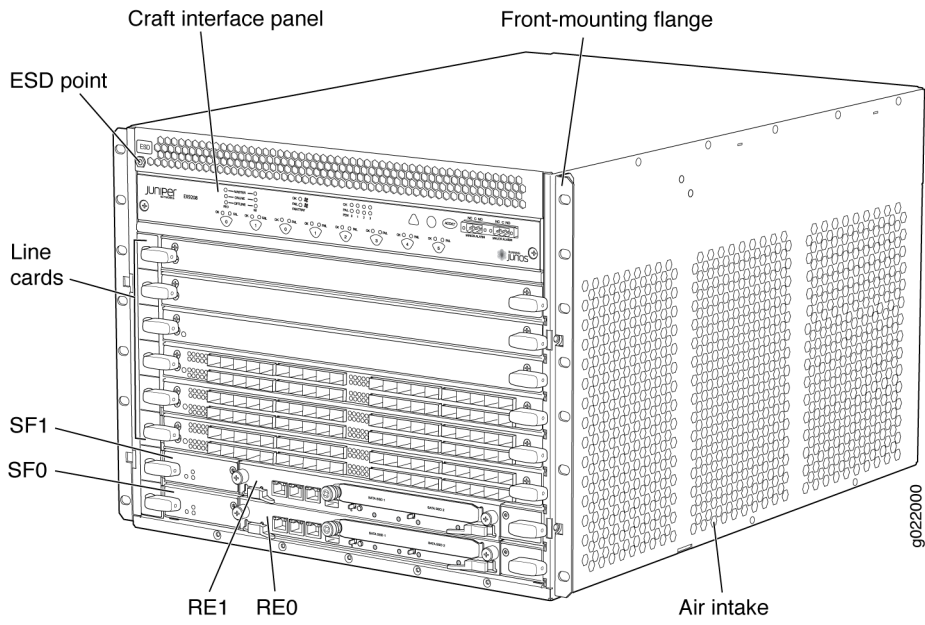

Figure 6: Rear View of an EX9208 Switch with AC Power Supplies

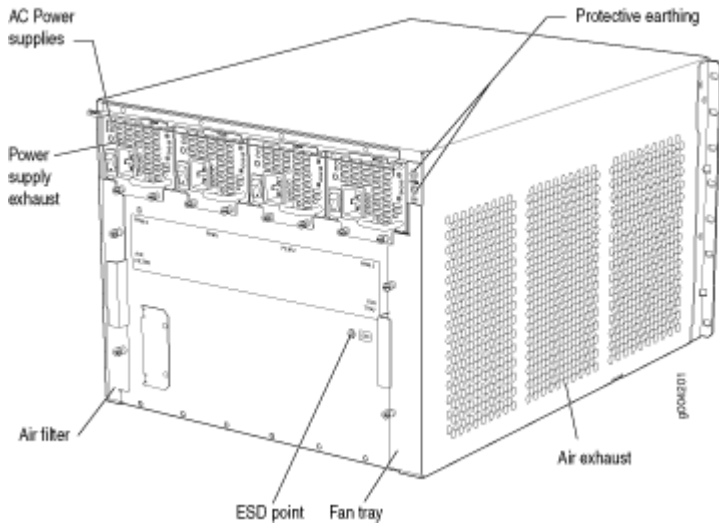
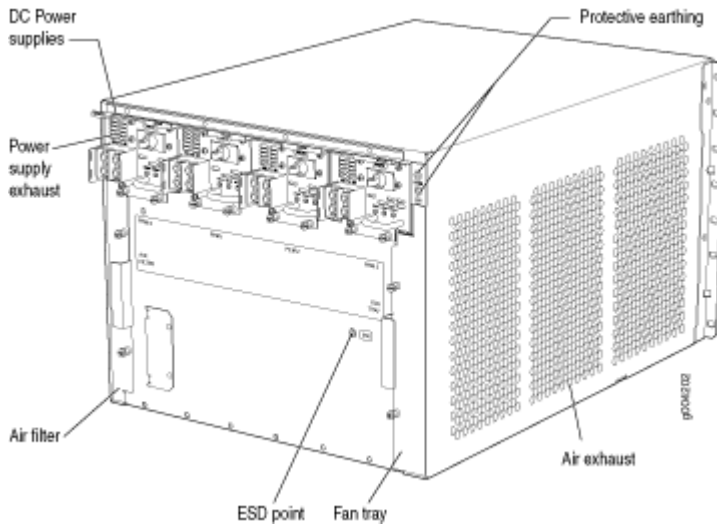

Figure 7: Rear View of an EX9208 Switch with DC Power Supplies



Host Subsystem

Switching and routing functionality, system management, and system control functions of an EX9208 switch are performed by the host subsystem. The host subsystem consists of a Routing Engine functioning together with a Switch Fabric.

You can install either one or two host subsystems in the slots labeled **0** and **1** in the front panel of the chassis. A base-configuration EX9208 switch has one host subsystem. A redundant-configuration EX9208 switch has a second host subsystem. For more information, see ["EX9208 Switch Configurations" on page 21](#).

Line Cards

The EX9208 switch has six horizontal line card slots and supports line rate for each line card. The line cards in EX9208 switches combine a Packet Forwarding Engine and Ethernet interfaces in a single assembly. Line cards are field-replaceable units (FRUs) that you can install in the line card slots—labeled **0** through **5**—on the front of the switch chassis. All line cards are hot-removable and hot-insertable. [Table 3 on page 19](#) lists the line cards available for EX9208 switches.

Table 3: Line Cards Available for EX9208 Switches

Model	Description	Additional Information
EX9200-2C-8XS	A line card with two 100-Gigabit Ethernet ports and eight 10-Gigabit Ethernet ports	<i>EX9200-2C-8XS Line Card</i>
EX9200-4QS	A line card with four 40-Gigabit Ethernet ports	<i>EX9200-4QS Line Card</i>
EX9200-6QS	A line card with six 40-Gigabit Ethernet ports and 24 10-Gigabit Ethernet ports	<i>EX9200-6QS Line Card</i>
EX9200-MPC	A modular line card that accepts any of the following MICs: <ul style="list-style-type: none"> • EX9200-10XS-MIC • EX9200-20F-MIC • EX9200-40T-MIC 	<i>EX9200-MPC Line Card</i>
EX9200-12QS	A line card with six 40-Gigabit Ethernet rate-selectable ports, each of which can house transceivers	<i>EX9200-12QS Line Card</i>
EX9200-15C	line card with 15 rate-selectable ports. All ports can operate at 10-Gbps, 25-Gbps, 40-Gbps, or 100-Gbps speeds	<i>EX9200-15C Line Card</i>
EX9200-32XS	A line card with 32 10-Gigabit Ethernet ports	<i>EX9200-32XS Line Card</i>
EX9200-40T	A line card with 40 10/100/1000BASE-T ports that support RJ-45 connectors	<i>EX9200-40T Line Card</i>

Table 3: Line Cards Available for EX9208 Switches (Continued)

Model	Description	Additional Information
EX9200-40F	A line card with 40 1-Gigabit Ethernet ports	<i>EX9200-40F Line Card</i>
EX9200-40F-M	A line card with 40 1-Gigabit Ethernet ports with Media Access Control Security (MACsec) capability	<i>EX9200-40F-M Line Card</i>
EX9200-40XS	A line card with 40 10-Gigabit Ethernet ports with Media Access Control Security (MACsec) capability, each of which can house 10-gigabit small form-factor pluggable plus (SFP+) transceivers	<i>EX9200-40XS Line Card</i>

Cooling System

The cooling system in an EX9208 switch is a field-replaceable unit (FRU). It consists of a hot-removable and hot-insertable fan tray. The fan tray contains six fans. The fan tray installs vertically on the right back of the chassis and provides side-to-side chassis cooling. See ["EX9208 Cooling System" on page 51](#).

Power Supplies

Power supplies for the EX9208 switch are fully redundant, load-sharing, and hot-removable and hot-insertable FRUs. Each EX9208 switch chassis can hold up to four AC or DC power supplies.

[Table 4 on page 20](#) shows the details of the power supplies available for EX9208 switches.

Table 4: Power Supplies Supported on EX9208 Switches

Power Supply	Input Voltage	Output Power
2520 W AC	Low-voltage line (100–120 VAC)	1167 W

Table 4: Power Supplies Supported on EX9208 Switches (Continued)

Power Supply	Input Voltage	Output Power
	High-voltage line (200–240 VAC)	2050 W
2400 W DC	–40 VDC through –70 VDC	2400 W to 2600 W

A base-configuration EX9208 switch ships with three low-line (100–120 VAC) or two high-line (200–240 VAC) AC power supplies. An AC-powered, redundant-configuration EX9208 switch ships with four low-line (100–120 VAC) or four high-line (200–240 VAC) AC power supplies. See ["AC Power Supply in an EX9208 Switch" on page 54](#).

A DC-powered, redundant-configuration EX9208 switch ships with four DC power supplies. See ["DC Power Supply in an EX9208 Switch" on page 61](#).



CAUTION: Do not mix AC and DC power supplies in the same chassis.

EX9208 Switch Configurations

[Table 5 on page 22](#) lists the hardware configurations for an EX9208 switch—base (AC) and redundant (AC and DC versions)—and the components included in each configuration.

Table 5: EX9208 Switch Hardware Configurations

Switch Configuration	Configuration Components	First Junos OS Release
<p>EX9208-BASE3C-AC</p> <p>(base configuration with 2520 W AC power supplies)</p>	<ul style="list-style-type: none"> • Chassis with craft interface and midplane • One EX9200-SF3 module • One EX9200-RE2 module • One fan tray • Three 2520 W AC power supplies • Blank panels for the line card slots • Blank panel for the empty power supply slot 	20.3R1
<p>EX9208-RED3C-DC</p> <p>(redundant configuration with 2520 W AC power supplies)</p>	<ul style="list-style-type: none"> • Chassis with craft interface and midplane • Two EX9200-SF3 modules • Two EX9200-RE2 modules • One fan tray • Four 2520 W DC power supplies • Blank panels for line card slots 	20.3R1
<p>EX9208-RED3C-AC</p> <p>(redundant configuration with 2520 W AC power supplies)</p>	<ul style="list-style-type: none"> • Chassis with craft interface and midplane • Two EX9200-SF3 modules • Two EX9200-RE2 modules • One fan tray • Four 2520 W AC power supplies • Blank panels for line card slots 	20.3R1

Table 5: EX9208 Switch Hardware Configurations (*Continued*)

Switch Configuration	Configuration Components	First Junos OS Release
EX9208-BASE3B-AC (base configuration with 2520 W AC power supplies)	<ul style="list-style-type: none"> • Chassis with craft interface and midplane • One EX9200-SF2 module • One EX9200-RE2 module • One fan tray • Three 2520 W AC power supplies • Blank panels for the line card slots • Blank panel for the empty power supply slot 	17.1R1
EX9208-RED3B-DC (redundant configuration with 2520 W AC power supplies)	<ul style="list-style-type: none"> • Chassis with craft interface and midplane • Two EX9200-SF2 modules • Two EX9200-RE2 modules • One fan tray • Four 2520 W DC power supplies • Blank panels for line card slots 	17.1R1
EX9208-RED3B-AC (redundant configuration with 2520 W AC power supplies)	<ul style="list-style-type: none"> • Chassis with craft interface and midplane • Two EX9200-SF2 modules • Two EX9200-RE2 modules • One fan tray • Four 2520 W AC power supplies • Blank panels for line card slots 	17.1R1

Table 5: EX9208 Switch Hardware Configurations (*Continued*)

Switch Configuration	Configuration Components	First Junos OS Release
EX9208-BASE3A-AC (base configuration with 2520 W AC power supplies)	<ul style="list-style-type: none"> • Chassis with craft interface and midplane • One EX9200-SF2 module • One EX9200-RE module • One fan tray • One air filter kit • Three 2520 W AC power supplies • One EX9200-SF module cover panel • Six line card cover panels • Blank panels for empty power supply slots 	14.1
EX9208-REDUND3A-AC (redundant configuration with 2520 W AC power supplies)	<ul style="list-style-type: none"> • Chassis with craft interface and midplane • Two EX9200-SF2 modules • Two EX9200-RE modules • One fan tray • One air filter kit • Four 2520 W AC power supplies • Six line card cover panels 	14.1

Table 5: EX9208 Switch Hardware Configurations (*Continued*)

Switch Configuration	Configuration Components	First Junos OS Release
EX9208-REDUND3A-DC (redundant configuration with 2400 W DC power supplies)	<ul style="list-style-type: none"> • Chassis with craft interface and midplane • Two EX9200-SF2 modules • Two EX9200-RE modules • One fan tray • One air filter kit • Four 2400 W DC power supplies • Six line card cover panels 	14.1
EX9208-BASE-AC (base configuration with 2520 W AC power supplies)	<ul style="list-style-type: none"> • Chassis with craft interface and midplane • One EX9200-SF module • One EX9200-RE module • One fan tray • One air filter kit • Three 2520 W AC power supplies • One EX9200-SF module cover panel • Six line card cover panels • Blank panels for empty power supply slots 	12.3R2

Table 5: EX9208 Switch Hardware Configurations (*Continued*)

Switch Configuration	Configuration Components	First Junos OS Release
EX9208-REDUND-AC (redundant configuration with 2520 W AC power supplies)	<ul style="list-style-type: none"> • Chassis with craft interface and midplane • Two EX9200-SF modules • Two EX9200-RE modules • One fan tray • One air filter kit • Four 2520 W AC power supplies • Six line card cover panels 	12.3R2
EX9208-REDUND-DC (redundant configuration with 2400 W DC power supplies)	<ul style="list-style-type: none"> • Chassis with craft interface and midplane • Two EX9200-SF modules • Two EX9200-RE modules • One fan tray • One air filter kit • Four 2400 W DC power supplies • Six line card cover panels 	12.3R2

NOTE: You can install up to six line cards (in any combination) in the switch.

NOTE: Line cards are not part of the base or redundant configuration. You must order them separately.

NOTE: Power cords and additional power supplies (AC or DC) must be purchased separately.

EX9208 Switch Hardware and CLI Terminology Mapping

This topic describes the hardware terms used in EX9208 switch documentation and the corresponding terms used in the Junos OS CLI. See [Table 6 on page 27](#).

Table 6: CLI Equivalents of Terms Used in Documentation for EX9208 Switches

Hardware Item (CLI)	Description (CLI)	Value (CLI)	Item in Documentation	Additional Information
Chassis	EX9208	-	Switch chassis	"Chassis Physical Specifications of an EX9208 Switch" on page 32
Midplane	One of the following: <ul style="list-style-type: none"> EX9208-BP EX9208-BP3 	-	Switch midplane	<i>Midplane in an EX9200 Switch</i>
FPM Board	Front Panel Display	-	Craft Interface	<i>Craft Interface in an EX9200 Switch</i>
PEM (<i>n</i>)	One of the following: <ul style="list-style-type: none"> PS 1.4-2.52 kW; 90-264 V AC in DC 2.4 kW Power Entry Module 	<i>n</i> is a value in the range 0-3. The value corresponds to the power supply slot number.	AC or DC power supply	<ul style="list-style-type: none"> "AC Power Supply in an EX9208 Switch" on page 54 "DC Power Supply in an EX9208 Switch" on page 61

Table 6: CLI Equivalents of Terms Used in Documentation for EX9208 Switches (Continued)

Hardware Item (CLI)	Description (CLI)	Value (CLI)	Item in Documentation	Additional Information
Routing Engine (<i>n</i>)	One of the following: <ul style="list-style-type: none"> • RE-S-EX9200-1800X4 • RE-S-EX9200-2X00x6 	<p><i>n</i> is a value in the range 0-1.</p> <p>In a base configuration, only one entry appears.</p> <p>In a redundant configuration, two entries appear—one for each Routing Engine module (RE module) installed in the chassis.</p>	RE module	<i>Routing Engine Module in an EX9200 Switch</i>
CB (<i>n</i>)	One of the following: <ul style="list-style-type: none"> • EX9200-SCBE • EX9200-SF2 • EX9200-SF3 	<p><i>n</i> is a value in the range 0-1.</p> <p>Multiple line items appear in the CLI if more than one Switch Fabric modules (SF modules) is installed in the chassis.</p> <p>CB0 and CB1 stand for SF modules.</p>	SF module	<i>Switch Fabric Module in an EX9200 Switch</i>

Table 6: CLI Equivalents of Terms Used in Documentation for EX9208 Switches (Continued)

Hardware Item (CLI)	Description (CLI)	Value (CLI)	Item in Documentation	Additional Information
FPC (<i>n</i>)	<p>Abbreviated name of the line card.</p> <p>One of the following:</p> <ul style="list-style-type: none"> • EX9200-2C-8XS • EX9200 4x40G QSFP • EX9200 24x10GE +6x40GE • EX9200-MPC • EX9200-12QS • EX9200-15C • EX9200 32x10G SFP • EX9200 40x1G Copper • EX9200-40x1G-SFP • EX9200-40FE • EX9200-40XS 	<p><i>n</i> is a value in the range 0-5. The value corresponds to the line card slot number in which the line card is installed.</p>	<p>Line card (The switch does not have actual FPCs—the line cards are the FPC equivalents on the switch.)</p>	<ul style="list-style-type: none"> • <i>EX9200-2C-8XS Line Card</i> • <i>EX9200-4QS Line Card</i> • <i>EX9200-6QS Line Card</i> • <i>EX9200-MPC Line Card</i> • <i>EX9200-12QS Line Card</i> • <i>EX9200-15C Line Card</i> • <i>EX9200-32XS Line Card</i> • <i>EX9200-40T Line Card</i> • <i>EX9200-40F Line Card</i> • <i>EX9200-40F-M Line Card</i> • <i>EX9200-40XS Line Card</i>

Table 6: CLI Equivalents of Terms Used in Documentation for EX9208 Switches (Continued)

Hardware Item (CLI)	Description (CLI)	Value (CLI)	Item in Documentation	Additional Information
MIC (<i>n</i>)	<p>Abbreviated name of the Modular Interface Card (MIC).</p> <p>One of the following if EX9200-MPC line card is installed:</p> <ul style="list-style-type: none"> • 10X10GE SFPP • 20X1GE SFP MACSEC • 40x1GE RJ45 	<i>n</i> is a value in the range 0-1.	<p>Line card</p> <p>NOTE: The switch does not have actual MICs except in the EX9200-MPC line card—the line cards are the MIC equivalents on the switch. EX9200-MPC is a modular line card that accepts any of the following MICs:</p> <ul style="list-style-type: none"> • EX9200-10XS-MIC • EX9200-20F-MIC • EX9200-40T-MIC 	<ul style="list-style-type: none"> • <i>EX9200-2C-8XS Line Card</i> • <i>EX9200-4QS Line Card</i> • <i>EX9200-6QS Line Card</i> • <i>EX9200-MPC Line Card</i> • <i>EX9200-12QS Line Card</i> • <i>EX9200-15C Line Card</i> • <i>EX9200-32XS Line Card</i> • <i>EX9200-40T Line Card</i> • <i>EX9200-40F Line Card</i> • <i>EX9200-40F-M Line Card</i> • <i>EX9200-40XS Line Card</i>

Table 6: CLI Equivalents of Terms Used in Documentation for EX9208 Switches (Continued)

Hardware Item (CLI)	Description (CLI)	Value (CLI)	Item in Documentation	Additional Information
PIC (<i>n</i>)	Abbreviated name of the Physical Interface Card (PIC).	<i>n</i> is a value in the range 0-3.	Line card (The switch does not have actual PICs.)	<ul style="list-style-type: none"> • <i>EX9200-2C-8XS Line Card</i> • <i>EX9200-4QS Line Card</i> • <i>EX9200-6QS Line Card</i> • <i>EX9200-MPC Line Card</i> • <i>EX9200-12QS Line Card</i> • <i>EX9200-15C Line Card</i> • <i>EX9200-32XS Line Card</i> • <i>EX9200-40T Line Card</i> • <i>EX9200-40F Line Card</i> • <i>EX9200-40F-M Line Card</i> • <i>EX9200-40XS Line Card</i>
Xcvr (<i>n</i>)	Abbreviated name of the transceiver.	<i>n</i> is a value equivalent to the number of the port in which the transceiver is installed.	Optical transceivers	<i>Pluggable Transceivers Supported on EX9200 Switches</i>

Table 6: CLI Equivalents of Terms Used in Documentation for EX9208 Switches (Continued)

Hardware Item (CLI)	Description (CLI)	Value (CLI)	Item in Documentation	Additional Information
Fan tray	Enhanced Left Fan Tray	-	Fan tray	"EX9208 Cooling System" on page 51

Chassis Physical Specifications of an EX9208 Switch

The EX9208 switch chassis is a rigid sheet-metal structure that houses the other switch components. [Table 7 on page 32](#) summarizes the physical specifications of the EX9208 switch chassis. See [Figure 8 on page 35](#), [Figure 9 on page 35](#), and [Figure 10 on page 36](#).

Table 7: Physical Specifications of the EX9208 Switch Chassis

Description	Weight	Height	Width	Depth
Chassis	Chassis with midplane, craft interface (front-panel display), fan tray, aChassis Physical Specifications of an EX9208 Switch filter, and cable management brackets: 65.5 lb (29.7 kg) Maximum configuration: 163.6 lb (74.2 kg)	14.0 in. (35.6 cm)	17.5 in. (44.5 cm)	24.5 in. (62.2 cm) (from front to chassis rear) Total depth (including cable management brackets) 27.75 in. (70.5 cm)
Routing Engine module (RE module)	2.4 lb (1.9 kg)	1.25 in. (3.2 cm)	11 in. (27.9 cm)	7.75 in. (19.7 cm)

Table 7: Physical Specifications of the EX9208 Switch Chassis (Continued)

Description	Weight	Height	Width	Depth
Switch Fabric module (SF module)	9.6 lb (4.4 kg) (with Routing Engine installed)	1.25 in. (3.2 cm)	17 in. (43.2 cm)	22 in. (55.9 cm)
EX9200-SF3 Switch Fabric module	13.6 lb (6.2 kg)	1.2 in. (3.05 cm)	15.7 in. (39.87 cm)	21.2 in. (53.85 cm)
Fan Tray	6.8 lb (3.84 kg)	11.58 in. (29.4 cm)	1.76 in. (4.5 cm)	23.3 in. (59.2 cm)
Air filter	1.0 lb (0.5 kg)	10.1 in. (25.7 cm)	0.31 in. (0.8 cm)	22.23 in. (56.5 cm)
Cable Management Brackets	0.3 lb (0.8 kg)	9.9 in. (25.1 cm)	0.25 in. (0.6 cm)	4.5 in. (11.4 cm)
AC power supply	6.6 lb (2.99 kg)	1.75 in. (4.4 cm)	14.5 in. (36.8 cm)	4 in. (10.2 cm)
DC power supply	6.2 lb (2.81 kg)	1.75 in. (4.4 cm)	14.5 in. (36.8 cm)	4 in. (10.2 cm)
EX9200-2C-8XS line card	19.4 lb (8.8 kg)	1.25 in. (3.2 cm)	17 in. (43.2 cm)	22 in. (55.9 cm)
EX9200-4QS line card	16.8 lb (7.6 kg)	1.25 in. (3.2 cm)	17 in. (43.2 cm)	22 in. (55.9 cm)
EX9200-6QS line card	21 lb (9.25 kg)	1.25 in. (3.2 cm)	17 in. (43.2 cm)	22 in. (55.9 cm)
EX9200-MPC line card	15.96 lb (7.3 kg)	1.25 in. (3.2 cm)	17 in. (43.2 cm)	22 in. (55.9 cm)

Table 7: Physical Specifications of the EX9208 Switch Chassis (Continued)

Description	Weight	Height	Width	Depth
EX9200-10XS-MIC	1.54 lb (0.7 kg)	1.25 in. (3.2 cm)	6.67 in. (16.9 cm)	7.86 in. (20 cm)
EX9200-20F-MIC	1.2 lb (0.54 kg)	1.25 in. (3.2 cm)	6.67 in. (16.9 cm)	7.86 in. (20 cm)
EX9200-40T-MIC	1.9 lb (0.9 kg)	1.25 in. (3.2 cm)	13.36 in. (33.9 cm)	22 in. (55.9 cm)
EX9200-12QS line card	15.7 lb (7.12 kg)	1.25 in. (3.2 cm)	17 in. (43.2 cm)	22 in. (55.9 cm)
EX9200-15C line card	20.4 lb (9.25 kg)	1.2 in. (3.05 cm)	15.7 in. (39.87 cm)	21.2 in. (53.85 cm)
EX9200-32XS line card	19.2 lb (8.7 kg)	1.25 in. (3.2 cm)	17 in. (43.2 cm)	22 in. (55.9 cm)
EX9200-40T line card	14.0 lb (6.6 kg)	1.25 in. (3.2 cm)	17 in. (43.2 cm)	22 in. (55.9 cm)
EX9200-40F line card	14.8 lb (6.7 kg)	1.25 in. (3.2 cm)	17 in. (43.2 cm)	22 in. (55.9 cm)
EX9200-40F-M line card	14.8 lb (6.7 kg)	1.25 in. (3.2 cm)	17 in. (43.2 cm)	22 in. (55.9 cm)
EX9200-40XS line card	17 lb (7.7 kg)	1.25 in. (3.2 cm)	17 in. (43.2 cm)	22 in. (55.9 cm)

Figure 8: EX9208 Switch

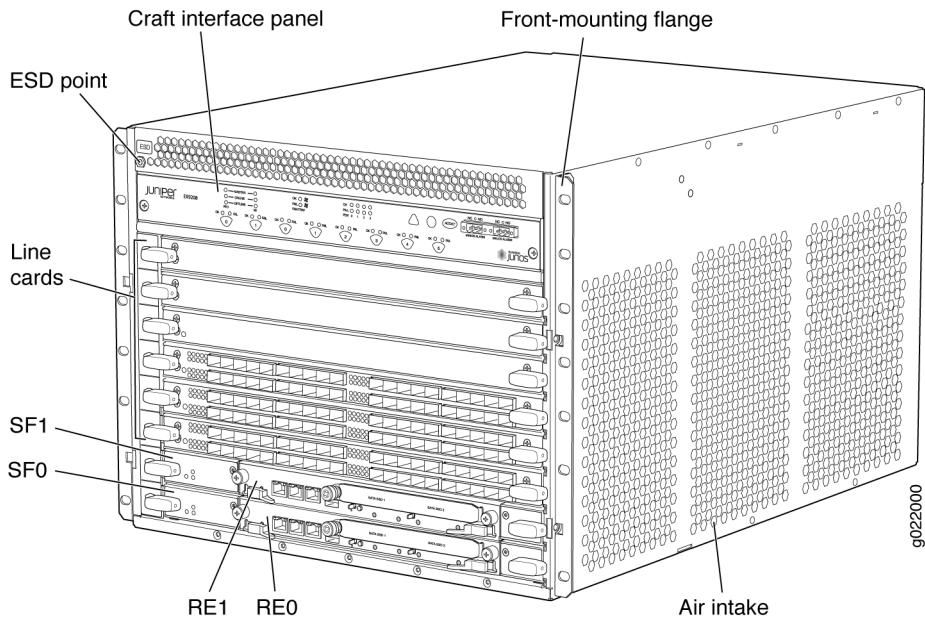

Figure 9: EX9208 Switch with AC Power Supplies

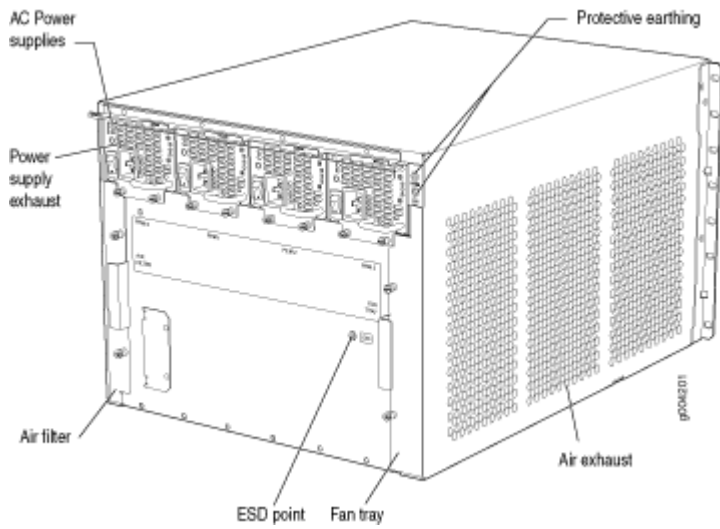
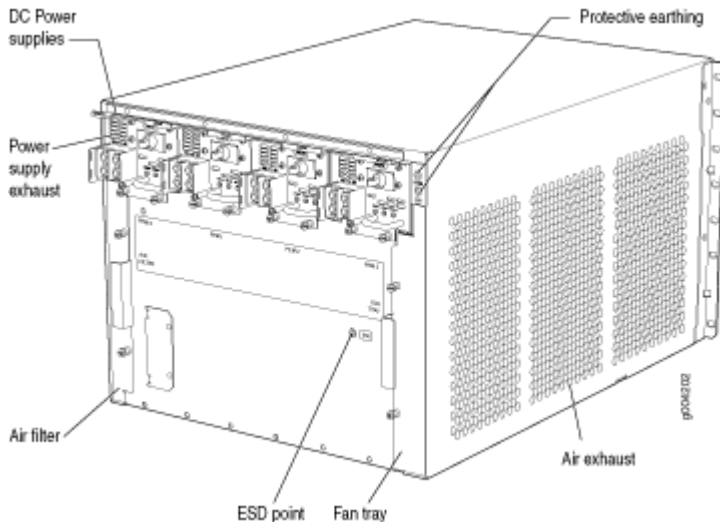

Figure 10: EX9208 Switch with DC Power Supplies



You can mount an EX9208 switch on a standard 19-in. four-post rack or a standard 800-mm enclosed cabinet. You can mount up to six EX9208 switches in a standard (48 rack unit (U)) rack.

SEE ALSO

[Installing and Removing EX9208 Switch Hardware Components](#)

Field-Replaceable Units in an EX9200 Switch

Field-replaceable units (FRUs) are switch components that you can replace at your site. The EX9200 switch uses the following types of FRUs:

- Hot-insertable and hot-removable—You can remove and replace these components without powering off the switch or disrupting the switching function.
- Hot-pluggable—You can remove and replace these components without powering off the switch, but the switching function is interrupted until you replace the component.

[Table 8 on page 37](#) lists the FRUs for the EX9200 switch and their types.

Table 8: FRUs in an EX9200 Switch

FRU	Type
Power supplies	Hot-insertable and hot-removable.
Fan tray and air filter	Hot-insertable and hot-removable.
Routing Engine module (RE module)	<p>Redundant configuration:</p> <ul style="list-style-type: none"> • Primary RE module is hot-pluggable. • Backup RE module is hot-insertable and hot-removable. <p>Base configuration:</p> <ul style="list-style-type: none"> • You must disable the switch before removing any RE module. See <i>Taking the Host Subsystem Offline in an EX9200 Switch</i>. <p>See <i>EX9204 Switch Configurations</i>, "EX9208 Switch Configurations" on page 21, and <i>EX9214 Switch Configurations</i>.</p>
Switch Fabric module (SF module)	<p>Redundant configuration:</p> <ul style="list-style-type: none"> • Primary SF module is hot-pluggable. • Backup SF module is hot-insertable and hot-removable. <p>Base configuration:</p> <ul style="list-style-type: none"> • You must disable the switch before removing any SF module. See <i>Taking the Host Subsystem Offline in an EX9200 Switch</i>. <p>See <i>EX9204 Switch Configurations</i>, "EX9208 Switch Configurations" on page 21, and <i>EX9214 Switch Configurations</i>.</p>
Line cards	Hot-insertable and hot-removable. We recommend that you take the line cards offline before removing them. See <i>Removing a Line Card from an EX9200 Switch</i> .

Table 8: FRUs in an EX9200 Switch (Continued)

FRU	Type
SFP, SFP+, QSFP+, and CFP transceivers <i>See Pluggable Transceivers Supported on EX9200 Switches for the Junos OS release in which the transceivers were introduced.</i>	Hot-insertable and hot-removable.

NOTE: Line cards are not part of the base or redundant configuration. You must order them separately.

NOTE: If you have a Juniper J-Care service contract, register any addition, change, or upgrade of hardware components at <https://www.juniper.net/customers/support/tools/updateinstallbase/> . Failure to do so can result in significant delays if you need replacement parts. This note does not apply if you replace existing components with the same type of component.

EX9208 Chassis

IN THIS SECTION

- [Understanding EX9208 Switch Component and Functionality Redundancy | 39](#)
- [Craft Interface in an EX9200 Switch | 40](#)
- [Midplane in an EX9200 Switch | 47](#)
- [Cable Management Brackets in an EX9208 Switch | 49](#)

Understanding EX9208 Switch Component and Functionality

Redundancy

The Juniper Networks EX9208 Ethernet Switches are available as fully redundant system. A redundant EX9208 switch configuration is designed so that no single point of failure can cause the entire switch to fail. See ["EX9208 Switch Configurations" on page 21](#).

The following hardware components provide redundancy to an EX9208 switch:

- **Host Subsystem**—The host subsystem consists of a Routing Engine functioning together with a Switch Fabric. The host subsystem performs switching and routing functionality, system management, and system control functions of the switch. The switch can have one or two host subsystems. If two host subsystems are installed, one functions as the primary and the other functions as the backup. If the primary host subsystem (or either of its components) fails, the backup can take over as the primary. To operate, each host subsystem requires a Routing Engine module (RE module) installed directly into in a Switch Fabric module (SF module).

If the Routing Engines are configured for graceful switchover, the backup Routing Engine automatically synchronizes its configuration and state with the primary Routing Engine. Any update to the primary Routing Engine state is replicated on the backup Routing Engine. If the backup Routing Engine assumes primary role, packet forwarding continues through the switch without interruption. See *Host Subsystem in an EX9200 Switch*.

- **Power supplies**—In the low-line (100 V) AC power configuration, the switch contains three or four AC power supplies, located horizontally at the rear of the chassis in slots **PEM0** through **PEM3** (left to right). Each AC power supply provides power to all components in the switch. When three power supplies are present, they share power almost equally within a fully populated system. Four AC power supplies provide full power redundancy. If one power supply fails or is removed, the remaining power supplies instantly assume the entire electrical load without interruption. Three power supplies provide the maximum configuration with full power for as long as the switch is operational.

In the high-line (200 V) AC power configuration, the switch contains two or four AC power supplies located horizontally at the rear of the chassis in slots **PEM0** through **PEM3** (left to right). Each AC power supply provides power to all components in the switch. When two or more power supplies are present, they share power almost equally within a fully populated system. Four AC power supplies provide full power redundancy. If one power supply fails or is removed, the remaining power supplies instantly assume the entire electrical load without interruption. Two power supplies provide the maximum configuration with full power for as long as the switch is operational.

In the DC configuration, two power supplies are required to supply power to a fully configured switch. One power supply supports approximately half of the components in the switch, and the other power supply supports the remaining components. The addition of two power supplies provides full power redundancy. If one power supply fails or is removed, the remaining power

supplies instantly assume the entire electrical load without interruption. Two power supplies provide the maximum configuration with full power for as long as the switch is operational.

See ["AC Power Supply in an EX9208 Switch" on page 54](#) and ["DC Power Supply in an EX9208 Switch" on page 61](#).

- Cooling system—The cooling system in EX9208 switches consists of fan tray and air filter. The fan tray contains six fans. Under normal operating conditions, the fans in the fan tray run at less than full speed. If one of the fans fails, the host subsystem increases the speed of the remaining fans to provide sufficient cooling for the switch indefinitely. See ["EX9208 Cooling System" on page 51](#).

Craft Interface in an EX9200 Switch

IN THIS SECTION

- [Host Subsystem LEDs | 42](#)
- [Fan LEDs | 43](#)
- [Power Supply \(PEM\) LEDs | 44](#)
- [Switch Fabric LEDs and Control Buttons | 44](#)
- [Line Card LEDs and Control Buttons | 45](#)
- [Alarm LEDs and Alarm Cutoff Button | 45](#)
- [Alarm Relay Contacts | 46](#)

The craft interface enables you to view status and troubleshooting information at a glance and to perform many system control functions. The craft interface is located on the front panel of the switch. It contains LEDs and on and off buttons for switch components, the alarm relay contacts, and an alarm cutoff button.

[Figure 11 on page 41](#) shows the craft interface in an EX9204 switch. [Figure 12 on page 41](#) shows the craft interface in an EX9208 switch. [Figure 13 on page 42](#) shows the craft interface in an EX9214 switch.

Figure 11: Craft Interface in an EX9204 Switch

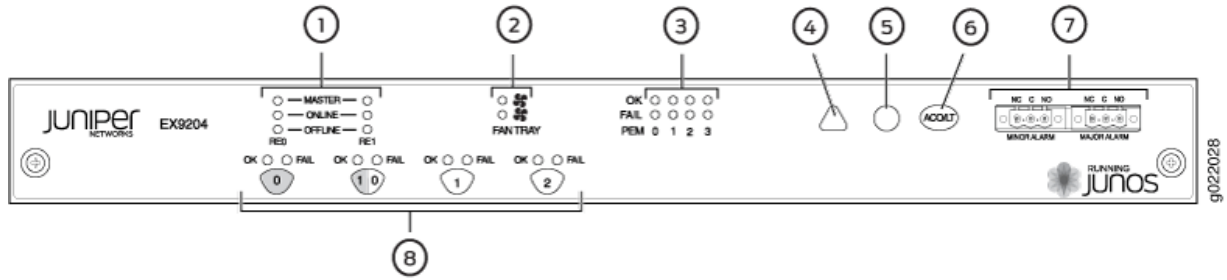

1– Host subsystem LEDs	5– Major alarm LED
2– Fan LEDs	6– Alarm cutoff/lamp test button
3– Power supply LEDs	7– Alarm relay contacts
4– Minor alarm LED	8– LEDs and control buttons for Switch Fabric and Line cards

NOTE: You can install a line card or an SF module in the multifunctional slot labeled **10** in EX9204 switches. The corresponding LED displays information depending on the hardware installed in that slot.

Figure 12: Craft Interface in an EX9208 Switch

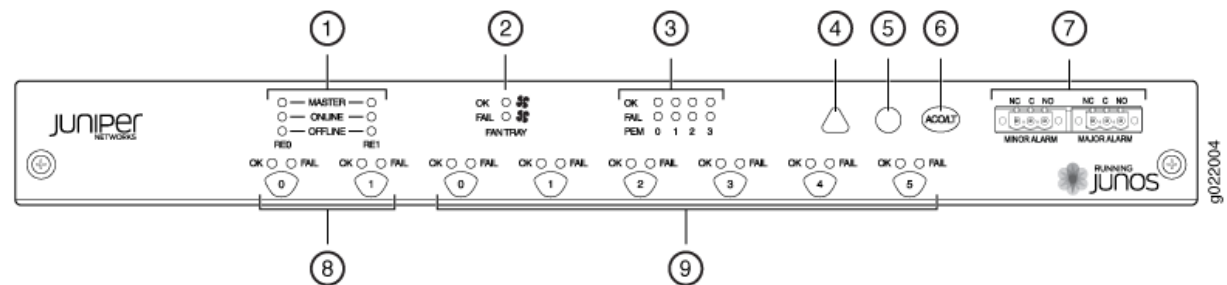

1– Host subsystem LEDs	6– Alarm cutoff/lamp test button
2– Fan LEDs	7– Alarm relay contacts
3– Power supply LEDs	8– Switch Fabric LEDs and control buttons
4– Minor alarm LED	9– Line card LEDs and control buttons
5– Major alarm LED	

Figure 13: Craft Interface in an EX9214 Switch

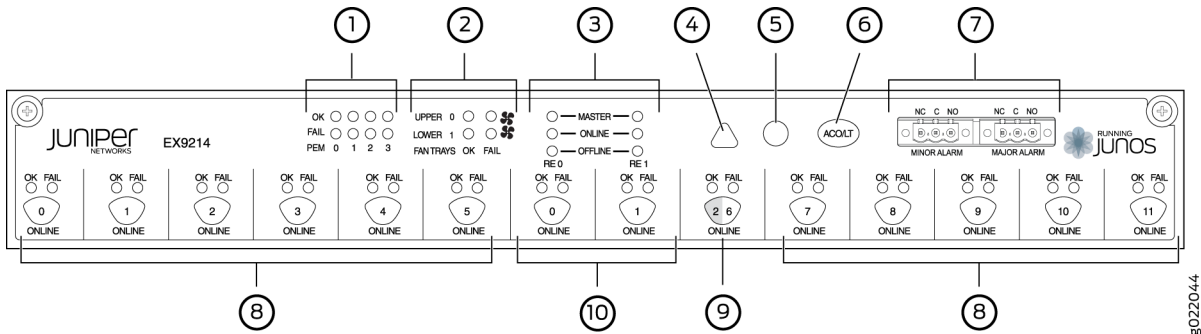

1– Power supply LEDs	6– Alarm cutoff/lamp test button
2– Fan LEDs	7– Alarm relay contacts
3– Host subsystem LEDs	8– Line card LEDs and control buttons
4– Minor alarm LED	9– Switch Fabric/line card LED and control button
5– Major alarm LED	10– Switch Fabric LEDs and control buttons

NOTE: You can install a line card or a Switch Fabric module (SF module) in slot nine—labeled **2 | 6**. The corresponding LED displays information depending on the hardware installed in that slot.

NOTE: At least one Switch Fabric module (SF module) with a Routing Engine module (RE module) must be installed in the switch for the craft interface to obtain power.

The craft interface has the following components:

Host Subsystem LEDs

Each host subsystem (RE module with SF module) has three LEDs, located on the upper left of the craft interface, to indicate its status. The LEDs grouped with labels **RE0** and **RE1** show the status of the host subsystems installed in the switch. [Table 9 on page 42](#) describes the functions of these LEDs.

Table 9: Host Subsystem LEDs on the Craft Interface

Label	Status	Description
MASTER	Green	Host subsystem is functioning as the primary.

Table 9: Host Subsystem LEDs on the Craft Interface (Continued)

Label	Status	Description
	Unlit	Host subsystem is either functioning as the backup or not installed.
ONLINE	Green	Host subsystem is online and is functioning normally.
	Unlit	Host subsystem is either offline or not installed.
OFFLINE	Red	Host subsystem is installed but Routing Engine is offline.
	Unlit	Host subsystem is not installed.

Fan LEDs

The fan LEDs are located on the top left of the craft interface. [Table 10 on page 43](#) describes the functions of the fan LEDs.

Table 10: Fan LEDs on the Craft Interface

Label	Status	Description
OK	Green	Fan is functioning normally.
	Unlit	Fan is not installed.
FAIL	Red	Fan has failed.
	Unlit	Fan is not installed or functioning normally.

Power Supply (PEM) LEDs

Each power supply has two LEDs on the craft interface that indicate its status. The LEDs—labeled **0** through **3**—are located on the craft interface next to the **PEM** label. [Table 11 on page 44](#) describes the functions of the power supply LEDs on the craft interface.

Table 11: Power Supply LEDs on the Craft Interface

Label	Status	Description
OK	Green	Power supply is functioning normally.
	Off	Power supply in not installed.
FAIL	Red	Power supply has failed.
	Off	Power supply is not installed or functioning normally.

Switch Fabric LEDs and Control Buttons

Each Switch Fabric module has two LEDs on the craft interface that indicates its status. The LEDs—**OK** and **FAIL**—are associated with control buttons and are located along the bottom of the craft interface. You can turn the SF modules on or off by pressing these buttons on the craft interface.

[Table 12 on page 44](#) describes the status of the SF module LEDs.

Table 12: Switch Fabric Module LEDs on the Craft Interface

Label	Status	Description
OK	Green	On steadily—The SF module is functioning normally.
		Blinking—The SF module is coming online or going offline.
	Unlit	The SF module is not online.

Table 12: Switch Fabric Module LEDs on the Craft Interface (Continued)

FAIL	Red	The SF module has failed.
	Unlit	The SF module is not installed or is not functioning normally.

Line Card LEDs and Control Buttons

Each line card has two LEDs—**OK** and **FAIL**—on the craft interface that indicates its status. The line card LEDs are associated with control buttons and are located along the bottom of the craft interface. You can turn a line card online or offline by using its control button on the craft interface. [Table 13 on page 45](#) describes the function of the line card LEDs.

Table 13: Line Card LEDs on the Craft Interface

Label	Status	Description
OK	Green	On steadily—Line card is functioning normally.
		Blinking—Line card is coming online or going offline.
	Unlit	Line card is not online.
FAIL	Red	Line card has failed.
	Unlit	Line card is not installed or functioning normally.

Alarm LEDs and Alarm Cutoff Button



Two large alarm LEDs are located at the upper right of the craft interface. The circular LED called major alarm LED glows to indicate a critical condition that can result in a system shutdown. The triangular LED called minor alarm LED glows to indicate a less severe condition (warning) that requires monitoring or maintenance. Both LEDs can be lit simultaneously.

A condition that causes an LED to be lit also activates the corresponding alarm relay contact on the craft interface.

The alarm cutoff/lamp test (**ACO/LT**) button, located next to the alarm LEDs, is a control button for alarms. You can press the **ACO/LT** button to deactivate major and minor alarms. Deactivating an alarm turns off both LEDs and deactivates the device attached to the corresponding alarm relay contact on the craft interface.

[Table 14 on page 46](#) describes the alarm LEDs and the alarm cutoff/lamp test button.

Table 14: Alarm LEDs and Alarm Cutoff/Lamp Test Button

Alarm LEDs and Button	Status	Description
 Major alarm LED	Red	Indicates a critical condition that can cause the switch to stop functioning. Possible causes include component removal, failure, or overheating.
 Minor alarm LED	Yellow	Indicates a serious but nonfatal error condition, such as warning for a maintenance or a significant increase in component temperature.
 Alarm cutoff/lamp test button	-	Deactivates major and minor alarms. Causes all LEDs on the craft interface to light (for testing) when pressed and held.

Alarm Relay Contacts

The craft interface has two alarm relay contacts for connecting the switch to external alarm devices. Whenever a system condition triggers either the critical (major alarm) or warning (minor alarm) alarm on the craft interface, the alarm relay contacts are also activated. The alarm relay contacts are located on the upper right of the craft interface.

[Figure 14 on page 47](#) shows the alarm relay contacts in EX9200 switches.

Figure 14: Alarm Relay Contacts in EX9200 Switches

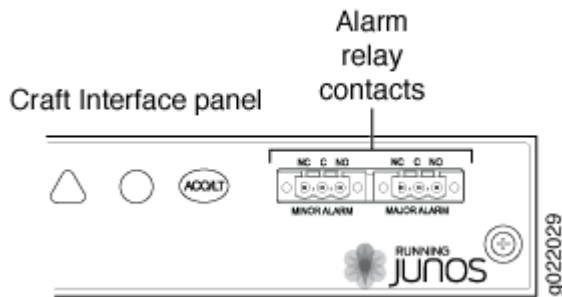

Midplane in an EX9200 Switch

The midplane is located on the rear of the chassis and forms the rear of the card cage. The Switch Fabric modules (SF modules) and line cards are installed into the midplane from the front of the chassis, and the power supplies install into the midplane from the rear of the chassis. The cooling system components also connect to the midplane.

The midplane performs the following major functions:

- Provides a data path—Data packets are transferred across the midplane between the line cards through the Switch Fabric on the host subsystem.
- Distributes power—The power supplies connect to the midplane, which distributes power to all the switch components.
- Provides a signal path—The midplane provides the signal path to the line cards, Switch Fabric, and other system components for monitoring and control of the system.

[Figure 15 on page 48](#) shows the midplane in an EX9204 switch. [Figure 16 on page 48](#) shows the midplane in an EX9208 switch. [Figure 17 on page 49](#) shows the midplane in an EX9214 switch.

Figure 15: Midplane in an EX9204 Switch

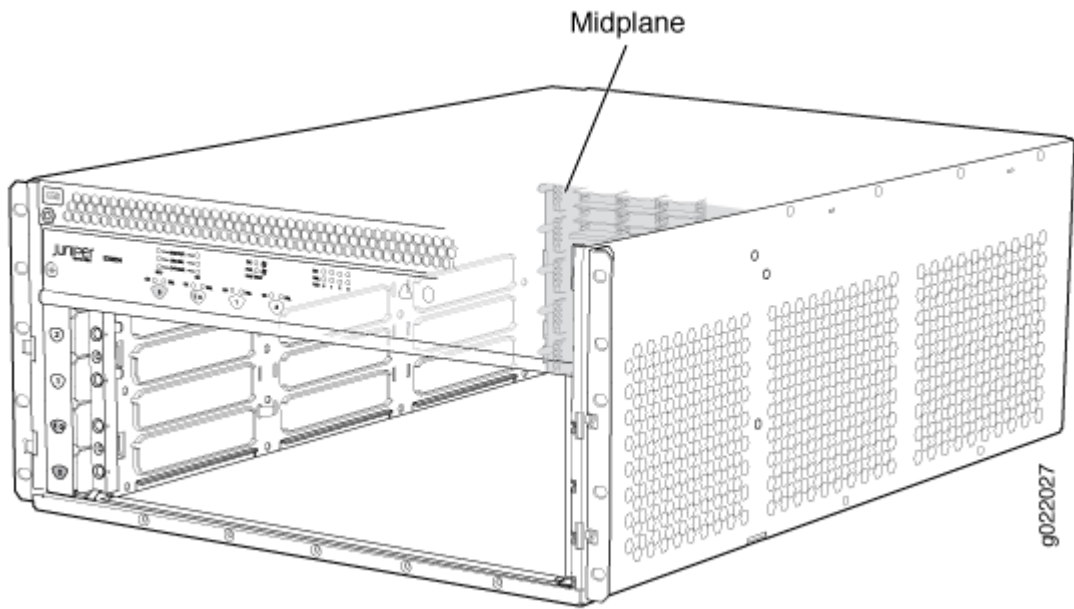

Figure 16: Midplane in an EX9208 Switch

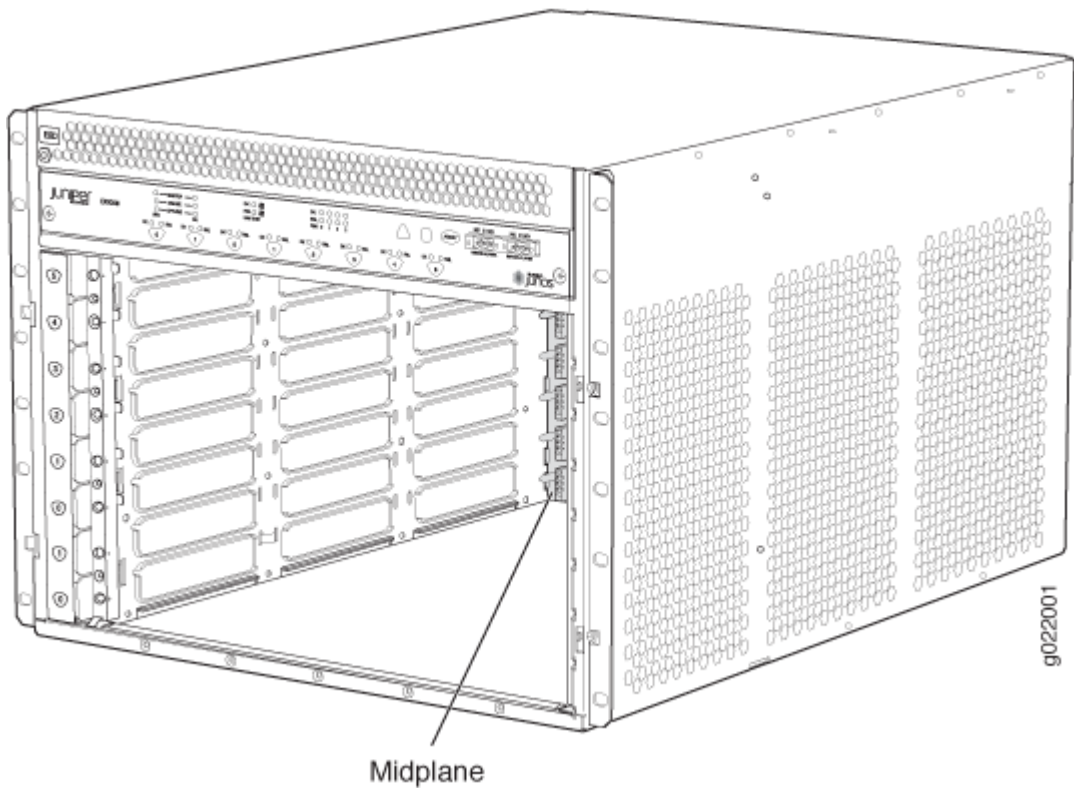
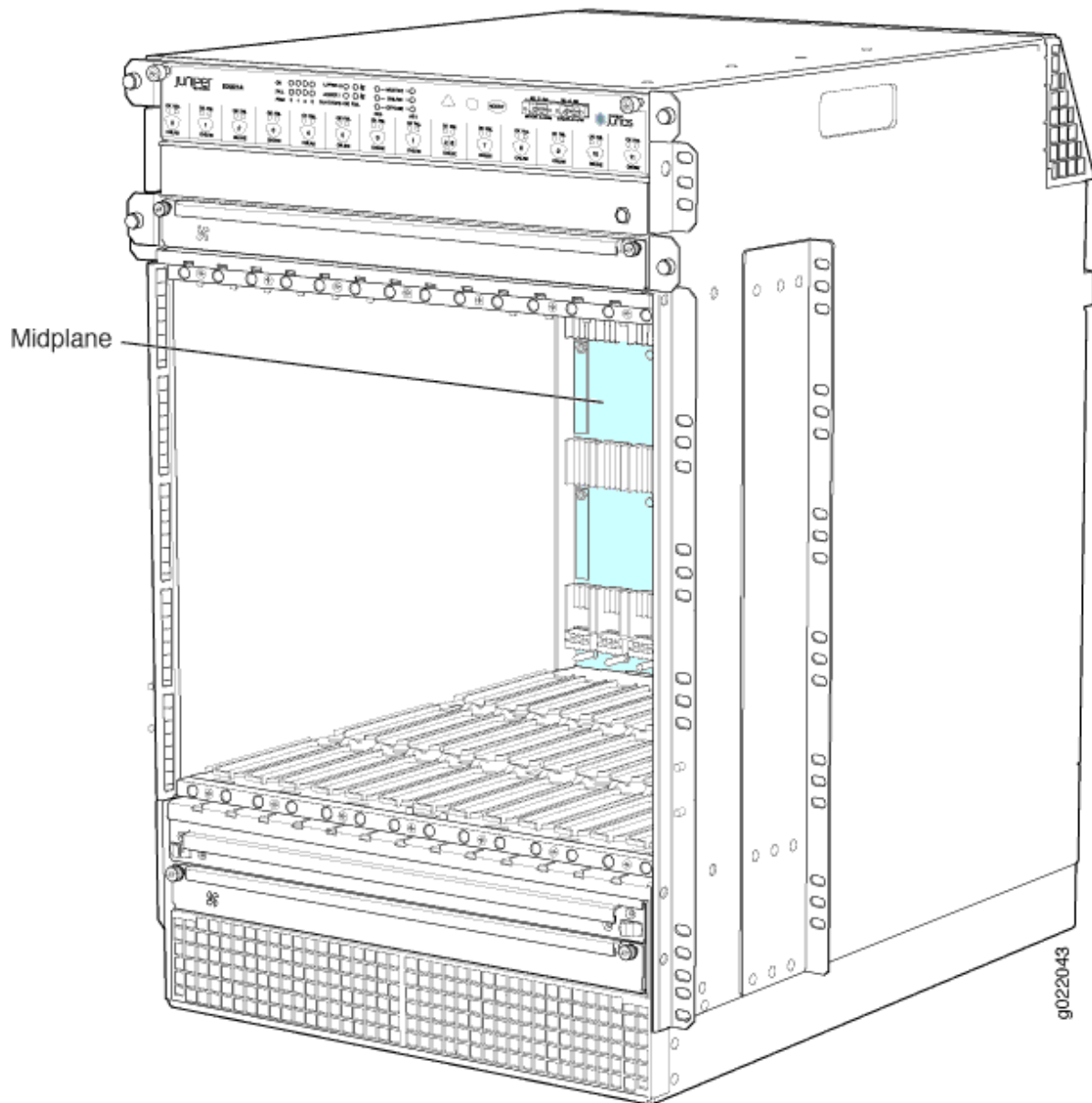

Figure 17: Midplane in an EX9214 Switch



Cable Management Brackets in an EX9208 Switch

The cable management brackets (see [Figure 18 on page 50](#)) consist of plastic dividers located on the left and right sides of each line card slot and Switch Fabric module (SF module) slot. The cable management brackets allow you to route the cables outside the switch and away from the line cards and SF modules.

Figure 18: Cable Management Brackets

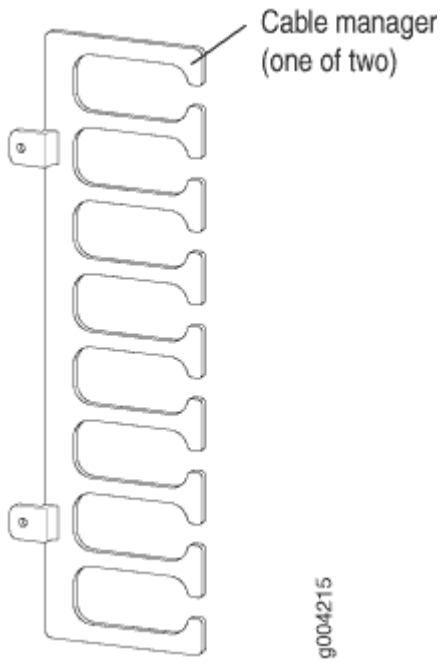
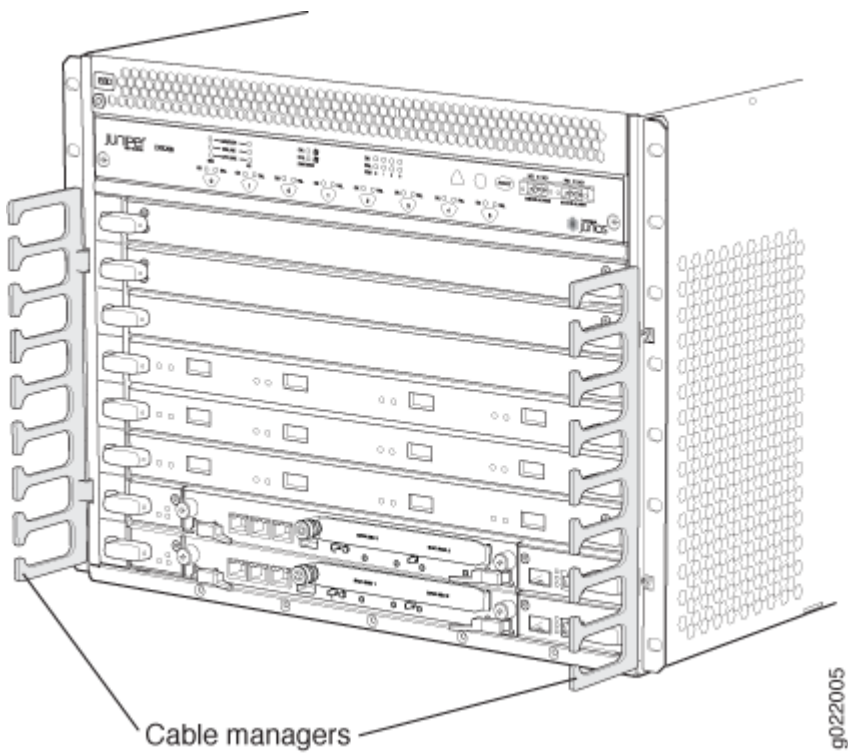

Figure 19: Cable Management Brackets Installed on the Switch



EX9208 Cooling System

IN THIS SECTION

- Fan Tray | 51
- Airflow Direction in the EX9208 Switch Chassis | 52

The cooling system in an EX9208 switch consists of a fan tray and an air filter. The cooling system components work together to keep all switch components within the acceptable temperature range.

Fan Tray

Fan tray is a hot-insertable and hot-removable field-replaceable unit (FRU) and contains six fans. The fan tray and air filter install vertically in the rear of the switch. See [Figure 20 on page 51](#) and [Figure 21 on page 52](#).

Figure 20: Fan Tray for an EX9208 Switch

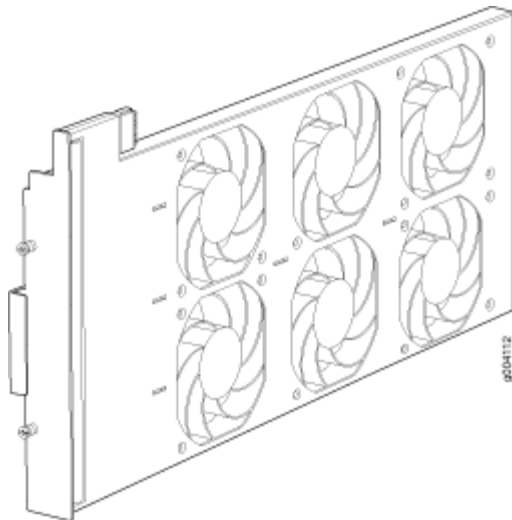
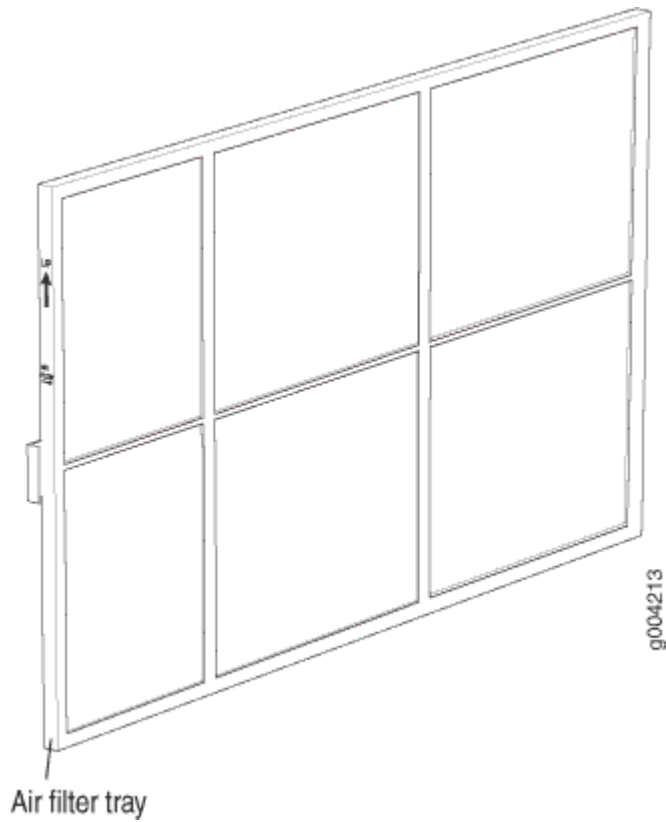

Figure 21: Air Filter for an EX9208 Switch



Airflow Direction in the EX9208 Switch Chassis

The air intake to cool the chassis is located on the side of the chassis next to the air filter. Air is pulled through the chassis toward the fan tray, where it is exhausted out through the side of the chassis. The air intake to cool the power supplies is located in the front of the chassis above the craft interface. See [Figure 22 on page 53](#).

Figure 22: Airflow Through the EX9208 Switch Chassis

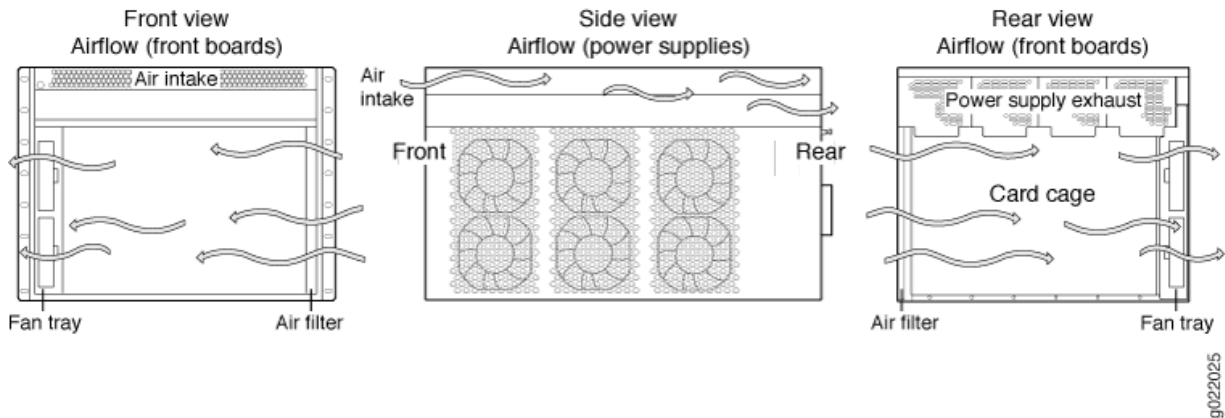

The host subsystem monitors the temperature of switch components. Under normal operating conditions, the fans in the fan tray run at less than full speed. If a fan fails or the ambient temperature rises above a threshold, the speed of the remaining fans is automatically adjusted to keep the temperature within the acceptable range. If the ambient maximum temperature specification is exceeded and the system cannot be adequately cooled, the Routing Engine shuts down the system by disabling output power from each power supply.

You cannot replace a single fan. If one or more fans fail, you must replace the entire fan tray.

RELATED DOCUMENTATION

[Clearance Requirements for Airflow and Hardware Maintenance for an EX9208 Switch](#) | 136

EX9208 Power System

IN THIS SECTION

- [AC Power Supply in an EX9208 Switch](#) | 54
- [AC Power Supply Specifications for EX9208 Switches](#) | 56
- [AC Power Cord Specifications for an EX9208 Switch](#) | 57
- [AC Power Supply LEDs in an EX9208 Switch](#) | 60
- [DC Power Supply in an EX9208 Switch](#) | 61

- [DC Power Supply Specifications for EX9208 Switches | 63](#)
- [DC Power Supply LEDs in an EX9208 Switch | 65](#)
- [Power Requirements for EX9200 Switch Components | 66](#)

AC Power Supply in an EX9208 Switch

IN THIS SECTION

- [AC Power Supply Description | 54](#)
- [AC Power Supply Configurations | 55](#)

An EX9208 switch is configurable with two, three, or four AC power supplies. The power supplies connect to the midplane, which distributes the different output voltages produced by the power supplies to the switch components, depending on their voltage requirements. Each power supply is cooled by its own internal cooling system.



CAUTION: EX9208 switches use either AC or DC power supplies. Do not mix AC and DC power supplies in a switch. The first type of power supply detected by the switch when initially powered on determines the type of power supply allowed by the switch. All installed power supplies of the other type are disabled by the switch. If you install a power supply of the other type while the switch is operating, the switch disables the power supply and generates an alarm.

This topic describes the AC power supplies in EX9208 switches.

AC Power Supply Description

The AC power supplies in EX9208 switches are hot-insertable and hot-removable field-replaceable units (FRUs).

You can install up to four AC power supplies in an EX9208 switch. Power supplies are installed in the rear of the chassis in slots **PEM0** through **PEM3** (left to right).



WARNING: The switch is installed in a restricted-access location. It has a separate protective earthing terminal (sized for UNC 1/4-20 ground lugs) provided on the chassis in addition to the grounding pin of the power supply cord. This separate protective earthing terminal must be permanently connected to earth.



CAUTION: Before switch installation begins, ensure that a licensed electrician has attached an appropriate grounding lug to the grounding cable that you supply. Using a grounding cable with an incorrectly attached lug can damage the switch.

Each AC power supply weighs approximately 6.6 lb (2.99 kg) and consists of one AC appliance inlet, an AC input switch, a fan, and LEDs to monitor the status of the power supply. See [Figure 23 on page 55](#).

Figure 23: AC Power Supply for an EX9208 Switch

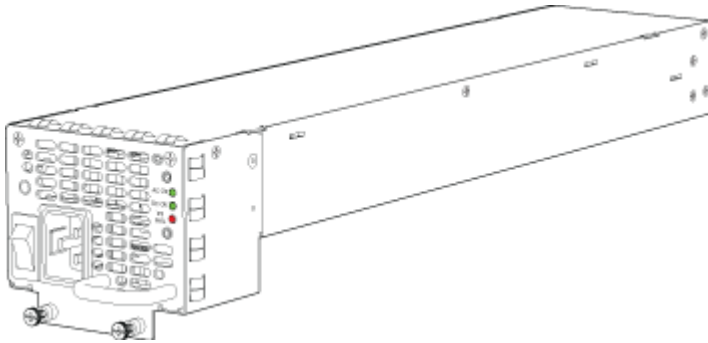

Each power supply has its own fan and is cooled by its own internal cooling system.

EX9208 switches support 2520 W AC power supply. The AC power supply supports both the low-voltage line (100–120 VAC) and the high-voltage line (200–240 VAC) AC power configurations.

Each AC power supply has a single AC appliance inlet located on the power supply that requires a dedicated AC power feed. We recommend that you use a customer site circuit breaker rated for 16.0 A @ 100 VAC or 16.0 A @ 200 VAC circuit breaker minimum for each AC power supply, or as required by local code. Doing so enables you to operate the switch in any configuration without upgrading the power infrastructure.

AC Power Supply Configurations

The EX9208 switch supports either the low-line (100–120 V) AC power configuration or the high-line (200–240 V) AC power configuration.

- In the low-line (100–120 V) AC power configuration, the EX9208 switch contains three or four AC power supplies, located horizontally at the rear of the chassis in slots **PEM0** through **PEM3** (left to right). Each AC power supply provides power to all components in the switch. When three power supplies are present, they share power almost equally within a fully populated system. Four AC power supplies provide full power redundancy. If one power supply fails or is removed, the remaining power supplies assume the entire electrical load without interruption. Three power supplies provide the maximum configuration with full power for as long as the switch is operational. The low-line configuration requires three power supplies and the fourth power supply provides redundancy.
- In the high-line (200–240 V) AC power configuration, the EX9208 switch contains two or four AC power supplies, located horizontally at the rear of the chassis in slots **PEM0** through **PEM3** (left to right). In a high-line AC power configuration, each AC power supply provides power to all components in the switch. When two or more power supplies are present, they share power almost equally within a fully populated system. Four AC power supplies provide full power redundancy. If one power supply fails or is removed, the remaining power supplies assume the entire electrical load without interruption. Two power supplies provide the maximum configuration with full power for as long as the switch is operational. In the two-PEM high-line configuration, slots **PEM0** and **PEM1** or **PEM2** and **PEM3** are used. The high-line configuration requires two power supplies, with the third and fourth providing redundancy.

SEE ALSO

| [Installing an AC Power Supply in an EX9208 Switch](#) | 222

AC Power Supply Specifications for EX9208 Switches

Table 15 on page 56 lists the power supply specifications for an AC power supply used in EX9208 switches.

Table 15: AC Power Supply Specifications for an EX9208 Switch

Item	Specifications
AC input voltage	Operating range: <ul style="list-style-type: none"> • Low-voltage line: 100–120 VAC • High-voltage line: 200–240 VAC

Table 15: AC Power Supply Specifications for an EX9208 Switch (Continued)

Item	Specifications
AC input line frequency	50–60 Hz
AC input current rating	<ul style="list-style-type: none"> • Low-voltage line: 16 A • High-voltage line: 15.1 A
AC output power	<ul style="list-style-type: none"> • Low-voltage line: 1167 W • High-voltage line: 2050 W

Table 16 on page 57 lists the AC power system specification for an EX9208 switch.

Table 16: AC Power System Specifications

Item	Low-Line	High-Line
Redundancy	3+1	2+2
Output power (maximum) per power supply	1167 W	2050 W
Output power (maximum) per system	3501 W	4100 W

AC Power Cord Specifications for an EX9208 Switch

Each AC power supply has a single AC appliance inlet located on the power supply that requires a dedicated AC power feed. Most sites distribute power through a main conduit that leads to frame-mounted power distribution panels, one of which can be located at the top of the rack that houses the switch. An AC power cord connects each power supply to the power distribution panel.

You can order detachable AC power cords, each approximately 8 ft (2.44 m) long that supply AC power to the switch. The C19 appliance coupler end of the cord inserts into the AC appliance inlet coupler, type C20 (right angle) as described by International Electrotechnical Commission (IEC) standard 60320.

The plug end of the power cord fits into the power source receptacle that is standard for your geographical location.

[Table 17 on page 58](#) provides specifications and [Figure 24 on page 59](#) depicts the plug on the AC power cord provided for each country or region.

Table 17: AC Power Cord Specifications for an EX9208 Switch

Country	Model Number	Electrical Specification	Plug Type
Australia	CBL-M-PWR-RA-AU	240 VAC, 50 Hz AC	SAA/3/15
China	CBL-M-PWR-RA-CH	220 VAC, 50 Hz AC	CH2-16P
Europe (except Denmark, Italy, Switzerland, and United Kingdom)	CBL-M-PWR-RA-EU	220 or 230 VAC, 50 Hz AC	CEE 7/7
Italy	CBL-M-PWR-RA-IT	230 VAC, 50 Hz AC	CEI 23-16/VII
Japan	CBL-PWR-RA-JP15	125 VAC, 50 or 60 Hz AC	JIS 8303
	CBL-M-PWR-RA-JP	220 VAC, 50 or 60 Hz AC	NEMA L6-20P
North America	CBL-PWR-RA-US15	125 VAC, 60 Hz AC	NEMA 5-15P
	CBL-PWR-RA-TWLK-US15	125 VAC, 60 Hz AC	NEMA L5-15P
	CBL-M-PWR-RA-US	250 VAC, 60 Hz AC	NEMA 6-20
	CBL-M-PWR-RA-TWLK-US	250 VAC, 60 Hz AC	NEMA L6-20P
United Kingdom	CBL-M-PWR-RA-UK	240 VAC, 50 Hz AC	BS89/13

Figure 24: AC Plug Types

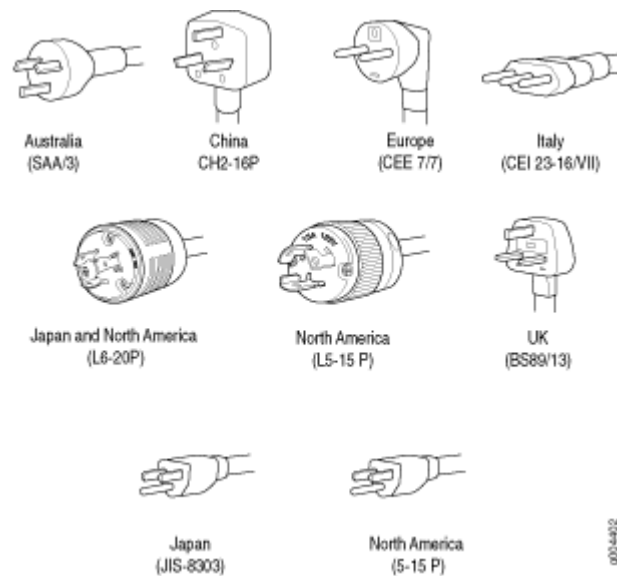

WARNING: The AC power cord for the switch is intended for use with the switch only and not for any other use.



WARNING:

注意

附属の電源コードセットはこの製品専用です。
他の電気機器には使用しないでください。

Translation from Japanese: The attached power cable is only for this product. Do not use the cable for another product.

NOTE: In North America, AC power cords must not exceed 4.5 m (approximately 14.75 ft) in length, to comply with National Electrical Code (NEC) Sections 400-8 (NFPA 75, 5-2.2) and 210-52, and Canadian Electrical Code (CEC) Section 4-010(3). You can order AC power cords that are in compliance.



WARNING: The switch is pluggable type A equipment installed in a restricted-access location. It has a separate protective earthing terminal (sized for UNC 1/4-20 ground

lugs) provided on the chassis in addition to the grounding pin of the power supply cord. This separate protective earthing terminal must be permanently connected to earth.



CAUTION: Power cords must not block access to switch components. We recommend that you route all AC power cord cables through the power cord tray provided with the switch.

AC Power Supply LEDs in an EX9208 Switch

An AC power supply has three LEDs on its faceplate. These LEDs display information about the status of the AC power supply. The power supply status is also reflected in two LEDs on the craft interface. In addition, a power supply failure triggers the major alarm LED on the craft interface.

[Table 18 on page 60](#) describes the LEDs on an AC power supply in an EX9208 switch.

Table 18: AC Power Supply LEDs on EX9208 Switches

LED	Color	Description
AC OK	Green	AC power input is within range. Power supply is functioning normally.
	Yellow	AC power input is below the range.
	Off	Indicates one of the following: <ul style="list-style-type: none"> Power supply is disconnected from AC power feed. No AC power input.
DC OK	Green	DC power output generated by the power supply is within the normal operating ranges.
	Off	DC power output generated by the power supply is not within the normal operating ranges.

Table 18: AC Power Supply LEDs on EX9208 Switches *(Continued)*

LED	Color	Description
PS FAIL	Red	Power supply is not functioning normally and its output voltage is out of regulation limits. Check AC OK and DC OK LEDs for more information.
	Off	Power supply is functioning normally.

DC Power Supply in an EX9208 Switch

IN THIS SECTION

- [DC Power Supply Description | 62](#)
- [DC Power Supply Configurations | 62](#)

An EX9208 switch is configurable with two or four DC power supplies. The power supplies connect to the midplane, which distributes the different output voltages produced by the power supplies to the switch components, depending on their voltage requirements. Each power supply is cooled by its own internal cooling system.



CAUTION: EX9208 switches use either AC or DC power supplies. Do not mix AC and DC power supplies in a switch. The first type of power supply detected by the switch when initially powered on determines the type of power supply allowed by the switch. All installed power supplies of the other type are disabled by the switch. If you install a power supply of the other type while the switch is operating, the switch disables the power supply and generates an alarm.

This topic describes the DC power supplies in EX9208 switches.

DC Power Supply Description

The DC power supplies in EX9000 switches are hot-insertable and hot-removable field-replaceable units (FRUs).

You can install either two or four DC power supplies in an EX9208 switch. Power supplies are installed in the rear of the chassis in slots **PEM0** through **PEM3** (left to right).

Each DC power supply weighs approximately 6.2 lb (2.81 kg) and consists of one DC input (–48 VDC and return), one 70 A (–48 VDC) circuit breaker, a fan, and LEDs to monitor the status of the power supply. See [Figure 25 on page 62](#).

Each DC power supply has a single DC input (–48 VDC and return) that requires a dedicated circuit breaker. We recommend you provision 60 A or 75 A per feed, depending on the selected DIP switch setting. If you plan to operate a maximally configured DC-powered switch with DC power supplies, we recommend that you use a dedicated customer site circuit breaker rated for 70 A (–48 VDC) minimum, or as required by local code.

If you plan to operate a DC-powered switch at less than the maximum configuration, we recommend that you provision a circuit breaker according to respective National Electrical Code and customer site internal standards to maintain proper level of protection for the current specified above or each DC power supply rated for at least 125% of the continuous current that the system draws at –48 VDC.

Figure 25: DC Power Supply for an EX9208 Switch

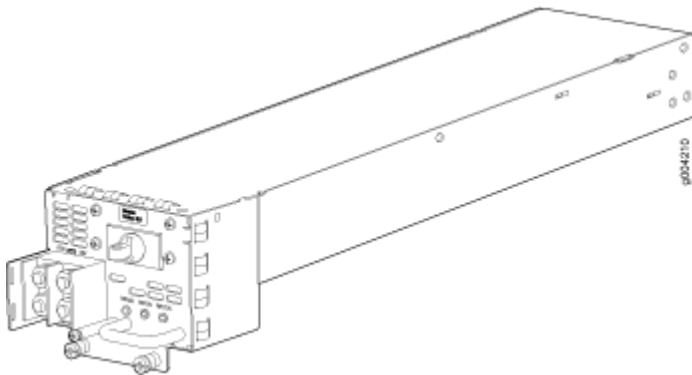

DC Power Supply Configurations

In the DC power configuration, the EX9208 switch contains either two or four DC power supplies located at the rear of the chassis in slots **PEM0** through **PEM3** (left to right). You can upgrade your DC power system from two to four power supplies.

Four power supplies provide full redundancy. If a DC power supply in a redundant configuration is removed or fails, its redundant power supply takes over without interruption. The DC power supply in

PEM2 serves as redundant to the DC power supply in slot **PEM0**, and the DC power supply in **PEM3** serves as redundant to the DC power supply in slot **PEM1**. If only two DC power supplies are installed, they must be installed in slots **PEM0** and **PEM1** or in slots **PEM2** and **PEM3**.

[Table 19 on page 63](#) shows the components that are powered by each DC power supply slot. It applies to existing and high-capacity power supplies.

Table 19: Power Supply Redundancy and Power Distribution

DC Power Supply Slot	Components That Are Supplied Power
PEM0	Fan tray, line card slots 0 and 1 , and SF slots 0 and 1
PEM1	Fan tray and line card slots 2 through 5
PEM2	Fan tray, line card slots 0 and 1 , and SF slots 0 and 1
PEM3	Fan tray and line card slots 2 through 5

SEE ALSO

| [Installing a DC Power Supply in an EX9208 Switch](#) | 226

DC Power Supply Specifications for EX9208 Switches

[Table 20 on page 64](#) lists the DC power supply specifications for EX9208 switches.

Table 20: DC Power Supply Specifications for an EX9208 Switch

Item	Specifications	
DC input voltage	Operating range: <ul style="list-style-type: none"> • Minimum operating range: -40.5 VDC • Nominal operating range: -48 VDC • Operating voltage range: -40.5 VDC to -72 VDC 	
Maximum Input Current	60 A (DIP=0)	70 A (DIP=1)
Maximum output power	2400 W	2600 W
DC input current rating	50 A @ -48 VDC normal operating voltage	54.2 A @ -48 VDC normal operating voltage

[Table 21 on page 64](#) lists the power system specifications for EX9208 switches.

Table 21: DC Power System Specifications

Item	Specifications	
Redundancy	2+2	
Output power (maximum) per supply	60 A (DIP=0)	70 A (DIP=1)
	2400 W	2600 W
Output power (maximum) per system	4800 W	5200 W

DC Power Supply LEDs in an EX9208 Switch

A DC power supply has three LEDs on its faceplate: **POWER OK**, **BRKR ON**, and **INPUT OK** LEDs. The power supply status is also reflected in two LEDs on the craft interface. In addition, a power supply failure triggers the major alarm LED on the craft interface.

NOTE: A host subsystem must be present for the **POWER OK** LED to be on.

Table 22 on page 65 describes the LEDs on a DC power supply in EX9208 switches.

Table 22: DC Power Supply LEDs in EX9208 Switches

LED	Color	Description
POWER OK	Green	Power supply is functioning normally.
	Yellow	The main output voltage is out of range.
	Off	Power supply is not functioning normally. Check the INPUT OK LED for more information.
BRKR ON	Green	DC power input is present and the DC power supply circuit breaker is turned on.
	Off	DC power supply circuit breaker is turned off.
INPUT OK	Green	DC input is present and is connected in correct polarity.
	Yellow	DC input is present, but is not in valid operating range or connected in reverse polarity.
	Off	DC input to the power supply is not present.

Power Requirements for EX9200 Switch Components

Table 23 on page 66 lists the power requirements for different hardware components of EX9200 switches.

Table 23: EX9200 Switch Component Power Requirements

Component	Typical Power (watt)	Reserved Power (watt)
Base system	<ul style="list-style-type: none"> EX9204 switch: 410 W EX9208 switch: 560 W EX9214 switch: 1290 W 	<ul style="list-style-type: none"> EX9204 switch: 410 W EX9208 switch: 560 W EX9214 switch: 1670 W
Redundant system	<ul style="list-style-type: none"> EX9204 switch: 690 W EX9208 switch: 800 W EX9214 switch: 1530 W 	<ul style="list-style-type: none"> EX9204 switch: 690 W EX9208 switch: 800 W EX9214 switch: 1910 W
EX9200-SF Switch Fabric module	150 W	150 W
EX9200-SF2 Switch Fabric module	155 W	155 W
EX9200-SF3 Switch Fabric module	245 W	270 W
Routing Engine module (RE module)	90 W	90 W
EX9200-2C-8XS line card	530 W	610 W
EX9200-4QS line card	408 W	520 W
EX9200-6QS line card	511 W	607 W
EX9200-MPC line card	461 W	534 W

Table 23: EX9200 Switch Component Power Requirements (Continued)

Component	Typical Power (watt)	Reserved Power (watt)
EX9200-10XS-MIC	29.8 W	29.8 W
EX9200-20F-MIC	37 W	37 W
EX9200-40T-MIC	41 W	41 W
EX9200-12QS line card	465 W	545 W
EX9200-15C line card	720 W	785 W
EX9200-32XS line card	550 W	610 W
EX9200-40T line card	206 W	239 W
EX9200-40F line card	219 W	239 W
EX9200-40F-M line card	219 W	239 W
EX9200-40XS line card	465 W	545 W

EX9200 Host Subsystem

IN THIS SECTION

- [Host Subsystem in an EX9200 Switch | 68](#)
- [Routing Engine Module in an EX9200 Switch | 69](#)
- [Routing Engine Module LEDs in an EX9200 Switch | 73](#)

- [Switch Fabric Module in an EX9200 Switch | 75](#)
- [Switch Fabric Module LEDs in an EX9200 Switch | 78](#)
- [EX9200-SF3 Module in an EX9200 Switch | 79](#)

Host Subsystem in an EX9200 Switch

Switching and routing functionality, system management, and system control functions of an EX9200 switch are performed by host subsystem. A host subsystem consists of a Routing Engine functioning together with a Switch Fabric.

You can install either one or two host subsystems in the front panel of an EX9204 or an EX9208 switch. A base configuration EX9204 and EX9208 switch has one host subsystem. A redundant configuration EX9204 and EX9208 switch has a second host subsystem.

You can install either two or three host subsystems in the front panel of an EX9214 switch. A base configuration EX9214 switch has two host subsystems. A redundant configuration EX9214 switch has a third host subsystem.

NOTE: In EX9204 and EX9208 switches, we recommend that you install two host subsystems for redundant protection. If you install only one host subsystem, we recommend that you install it in slot **0**. In EX9214 switches, we recommend that you install three host subsystems for redundant protection. If you install only two host subsystems, we recommend that you install it in slot **0** and **1**.

Each host subsystem has LEDs in the craft interface that display its status. See *Craft Interface in an EX9200 Switch*.

SEE ALSO

Taking the Host Subsystem Offline in an EX9200 Switch

Maintaining the Host Subsystem in EX9200 Switches

Routing Engine Module in an EX9200 Switch

The Routing Engine module (RE module) is an Intel-based platform that runs Juniper Networks Junos operating system (Junos OS). Software processes that run on the RE module maintain the routing tables, manage the routing protocols used on the switch, control the router interfaces and some of the chassis components, and provide the interface for system management and user access to the switch.

In an EX9204, EX9208, or EX9214 switch, you can install one or two RE modules in the Switch Fabric modules (SF modules) that are installed in slots on the front panel of the switch. If you install two RE modules, one functions as the primary and the other functions as the backup. If the primary RE module fails or is removed and the backup is configured appropriately, the backup takes over as the primary. The backup RE module is hot-insertable and hot-removable, whereas the primary RE module is only hot-insertable. See [Figure 26 on page 70](#) and [Figure 27 on page 71](#). A USB port on the RE module accepts a USB memory card that loads the Junos OS.

NOTE:

- In EX9214 switches, you must install an RE module only in the SF modules installed in slots 7 and 8 labeled **0** and **1**.
- If you have installed only one RE module, you must power off the switch before removing the RE module.

A base-configuration EX9204, EX9208, or EX9214 switch has only one RE module. See *EX9204 Switch Configurations*, ["EX9208 Switch Configurations" on page 21](#), and *EX9214 Switch Configurations*. You can add a second RE module to the configuration for redundancy.

NOTE: We recommend that you install two RE modules in EX9204, EX9208, and EX9214 switches for redundancy.

The RE module performs the following functions:

- Provides switching functionality to the switch through the switching plane
- Powers the line cards on and off
- Controls system resets and the boot sequence for the switch
- Monitors and controls the fan speed, power status for various chassis components, and craft interface LEDs

The switch ships with the RE modules preinstalled. There are two copies of the software:

- One copy on the solid-state drive (SSD) in the RE module.
- One copy on a USB flash drive that can be inserted into the slot on the RE module faceplate.

The RE module boots from the storage media in the following order: the USB device (if present), then the SSD, and finally the LAN.

NOTE: Starting with Junos OS Release 17.1R1, EX9200 switches support the EX9200-RE2 module. The EX9200-RE2 module supports virtual machine (VM) architecture in an EX9200 switch. Only the EX9200-SF2 module supports the EX9200-RE2 module. Starting with Junos OS Release 17.1R1, you cannot form a Virtual Chassis using an EX9200 switch.



CAUTION: The EX9200-RE module and the EX9200-RE2 module are not interoperable. Do not install both the RE modules in the same switch chassis.

NOTE: Starting with Junos OS Release 16.1, you can use EX9200 switches as an aggregation device in Junos Fusion Enterprise. Starting with Junos OS Release 17.4, you can use EX9200 switches with EX9200-RE2 module installed in it as an aggregation device in Junos Fusion Enterprise. See [Understanding Junos Fusion Enterprise Software and Hardware Requirements](#) for the list of line cards that support this configuration.

Figure 26 on page 70 shows the EX9200-RE module in an EX9200 switch.

Figure 26: EX9200-RE Module in an EX9200 Switch

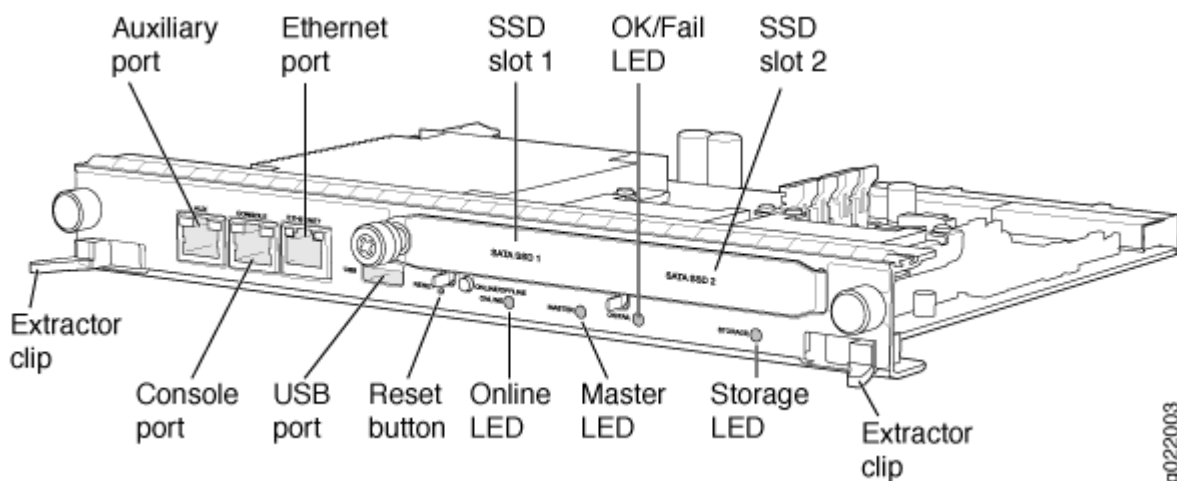

Each EX9200-RE module consists of the following components:

- Extractor clips—Control the locking system to securely install and remove the EX9200-RE module.
- **AUX** port—Connects the EX9200-RE module to a modem or other auxiliary device.
- **CONSOLE** port—Connects the EX9200-RE module to a system console through a cable with an RJ-45 connector. See *Connecting an EX9200 Switch to a Management Console or an Auxiliary Device*.
- **ETHERNET** port—Connects the EX9200-RE module through an Ethernet connection to a management LAN (or any other device that plugs into an Ethernet connection) for out-of-band management. See *Connecting an EX9200 Switch to a Network for Out-of-Band Management*.
- **USB** port—Hosts a removable media interface through which you can install the Junos OS manually. See *USB Port Specifications for an EX Series Switch*.
- **SATA SSD 1** and **SATA SSD 2** slots—Host primary storage for software images, configuration files, and microcode. Also provide secondary storage for log files and memory dump files.
- **RESET** button—Reboots the EX9200-RE module when pressed.
- **ONLINE/OFFLINE** button—Turns the EX9200-RE module online or offline when pressed.
- Status LEDs—Indicate the status of the EX9200-RE module. Each EX9200-RE module has four LEDs labeled **MASTER**, **STORAGE**, **ONLINE**, and **OK/FAIL** on the faceplate.
- Captive screws—Secure the EX9200-RE module in place.

Figure 27 on page 71 shows the EX9200-RE2 module in an EX9200 switch.

Figure 27: EX9200-RE2 Module in an EX9200 Switch

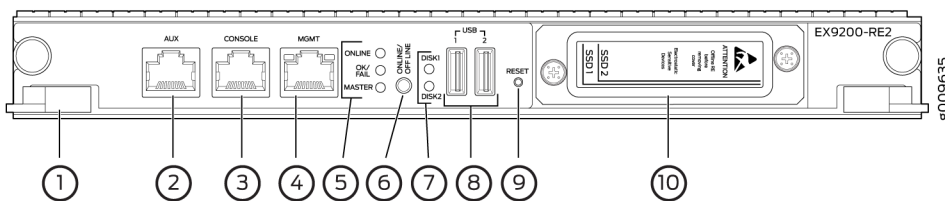

1– Extractor clips	6– ONLINE/OFFLINE button
2– Auxiliary port (AUX)	7– SSD LEDs— DISK1 and DISK2
3– Console port (CONSOLE)	8– USB ports— USB1 and USB2
4– Management port (MGMT)	9– RESET button
5– LEDs— ONLINE , OK/FAIL , and MASTER	10– SSD slots— SSD 1 and SSD 2

Each EX9200-RE2 module consists of the following components:

- Extractor clips—Control the locking system to securely install and remove the EX9200-RE2 module.
- **AUX** port—Connects the EX9200-RE2 module to a modem or other auxiliary device.
- **CONSOLE** port—Connects the EX9200-RE2 module to a system console through a cable with an RJ-45 connector. See *Connecting an EX9200 Switch to a Management Console or an Auxiliary Device*.
- **MGMT** port—Connects the EX9200-RE2 module through an Ethernet connection to a management LAN (or any other device that plugs into an Ethernet connection) for out-of-band management. See *Connecting an EX9200 Switch to a Network for Out-of-Band Management*.
- Status LEDs—Indicate the status of the EX9200-RE2 module. Each EX9200-RE2 module has five LEDs labeled **MASTER**, **ONLINE**, **OK/FAIL**, **DISK1**, and **DISK2** on the faceplate.
- **ONLINE/OFFLINE** button—Turns the EX9200-RE2 module online or offline when pressed.
- **USB1** and **USB2** ports—Host a removable media interface using which you can install the Junos OS manually. See *USB Port Specifications for an EX Series Switch*.
- **SSD 1** and **SSD 2** slots—Host primary storage for software images, configuration files, and microcode. Also provide secondary storage for log files and memory dump files.
- **RESET** button—Reboots the EX9200-RE2 module when pressed.
- Captive screws—Secure the EX9200-RE2 module in place.

For the specifications of the Routing Engine modules, see [Table 24 on page 72](#).

Table 24: Routing Engine Module Specifications

RE Module	Processor	Memory	Connecti on to Packet Forwardin g Engines	Disk	Media	First Junos OS Release
EX9200-RE	RE-S- EX9200-1800X4 (4 cores, 1.73 GHz)	16 GB	Gigabit Ethernet	32- GB hard disk	4- GB CompactFlash card	12.3R2
EX9200-RE2	RE-S- EX9200-2X00x6 (6 cores, 2 GHz)	64 GB	Gigabit Ethernet	50- GB SSD X 2	No flash memory	17.1R1

Routing Engine Module LEDs in an EX9200 Switch

Each Routing Engine module (RE module) has LEDs on the module faceplate. [Table 25 on page 73](#) describes the functions of these LEDs on the EX9200-RE and [Table 26 on page 73](#) describes the functions of these LEDs on the EX9200-RE2.

Table 25: LEDs on the EX9200-RE Routing Engine Module

LED Label	Status	State and Description
MASTER	Blue	RE module is functioning as the primary.
	Unlit	RE module is either functioning as the backup or not installed.
STORAGE	Green	Blinking—Indicates activity on the SSD.
ONLINE	Green	<ul style="list-style-type: none"> On steadily—RE module is operating normally. Blinking—RE module is coming online or going offline.
OK/FAIL	Red	RE module has failed.

Table 26: LEDs on the EX9200-RE2 Routing Engine Module

LED Label	Status	State and Description
MASTER	Blue	RE module is functioning as the primary.
	Unlit	RE module is either functioning as the backup or not installed.
ONLINE	Unlit	The RE is powered off

Table 26: LEDs on the EX9200-RE2 Routing Engine Module (*Continued*)

LED Label	Status	State and Description
	Green	<p>When the RE module is powering on:</p> <ul style="list-style-type: none"> Blinking slowly (LED is lit for a period of time and is unlit for thrice that period of time that follows, and this pattern is repeated)—RE module is coming online. Blinking fast (LED is lit for a period of time and is unlit for the subsequent same period of time, and this pattern is repeated)—Linux is booted. On steadily (LED glows steadily)—Junos OS is booted. <p>When the RE module is powering off:</p> <ul style="list-style-type: none"> Blinking fast (LED is lit for a period of time and is unlit for the subsequent same period of time, and this pattern is repeated)—Junos OS is powering off. Blinking slowly (LED is lit for a period of time and is unlit for thrice that period of time that follows, and this pattern is repeated)—Linux is powering off. Unlit—RE module is powered off.
OK/FAIL	Red	RE module has failed.
DISK1	Green	Blinking—Indicates activity on the SSD.
DISK2	Green	Blinking—Indicates activity on the SSD.

SEE ALSO

Installing an RE Module in an EX9200 Switch

Removing an RE Module from an EX9200 Switch

Switch Fabric Module in an EX9200 Switch

The Switch Fabric serves as the central nonblocking matrix through which all network data passes.

Switch Fabric modules (SF modules) are installed horizontally on the front panel of the switch chassis. You can install either one or two SF modules in an EX9204 or EX9208 switch and two or three SF modules in an EX9214 switch. A base-configuration EX9204 or EX9208 switch has only one SF module, and a base-configuration EX9214 switch has two SF modules. See *EX9204 Switch Configurations*, ["EX9208 Switch Configurations" on page 21](#), or *EX9214 Switch Configurations*.

In EX9204 and EX9208 switches, you can add a second SF module to the configuration for host subsystem redundancy. In EX9214 switches, you can add a third SF module to the configuration for host subsystem redundancy. If two SF modules are installed, one SF module functions as the primary and the other functions as the backup. If the primary SF module or its components fails or is removed, the backup module takes the role of primary.

The Routing Engine module (RE module) installs directly into a slot on the SF module. The Switch Fabric contains logic that determines which Routing Engine is the primary. The primary Routing Engine controls many internal functions of the SF module.

The backup SF module is hot-insertable and hot-removable, but the primary SF module is only hot-insertable.

The key functions of the Switch Fabric are:

- Monitor and control system functions
- Interconnection of all line cards
- Clocking, system resets, and booting control
- Routing Engine carrier

[Figure 28 on page 76](#) shows the original SF module, EX9200-SF.

Figure 28: SF Module EX9200-SF

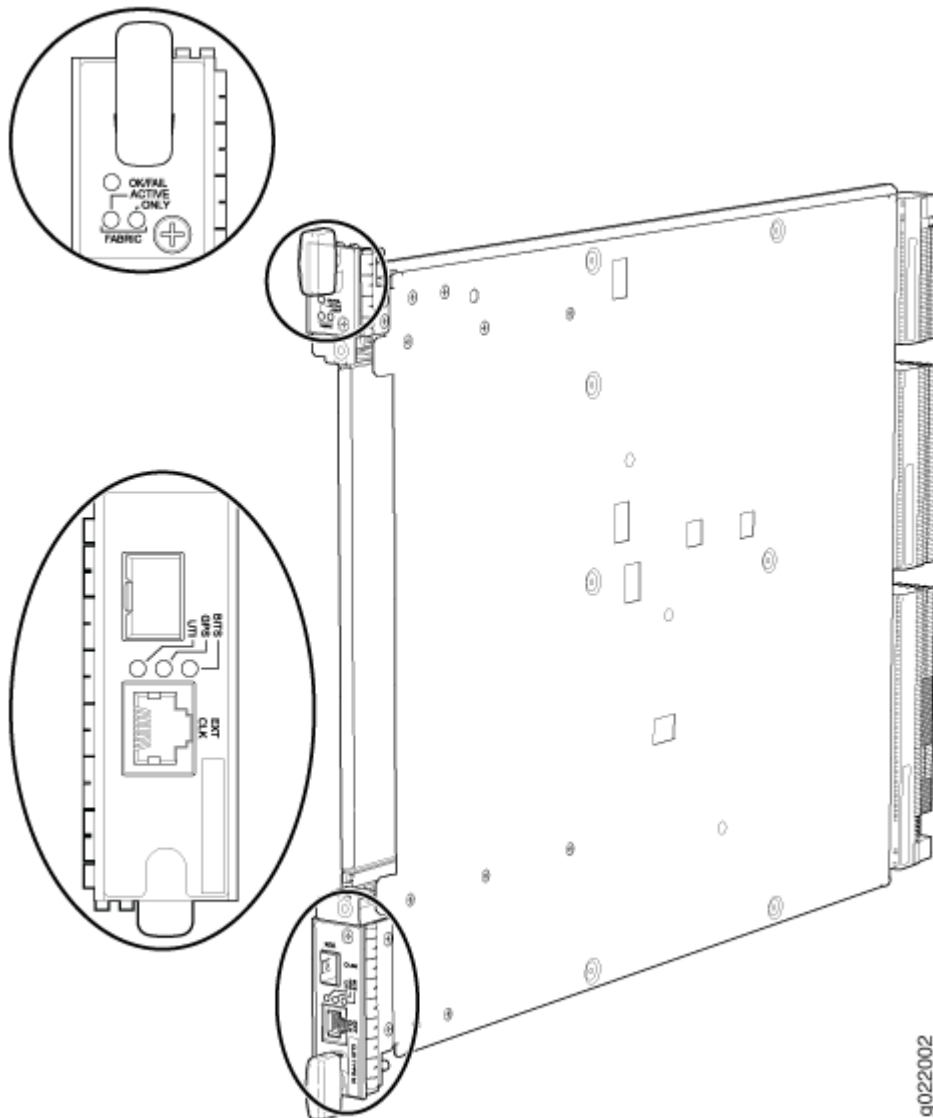

Starting with Junos OS Release 14.1, a high-speed SF module, EX9200-SF2, is available. Compared to the original SF module, EX9200-SF, the EX9200-SF2 offers increased bandwidth, providing higher-capacity traffic support in settings that require greater interface density (slot and capacity scale).

The EX9200-SF2 supports all EX9200 line cards.

[Figure 29 on page 77](#) shows the high-speed SF module, EX9200-SF2.

Figure 29: SF Module EX9200-SF2

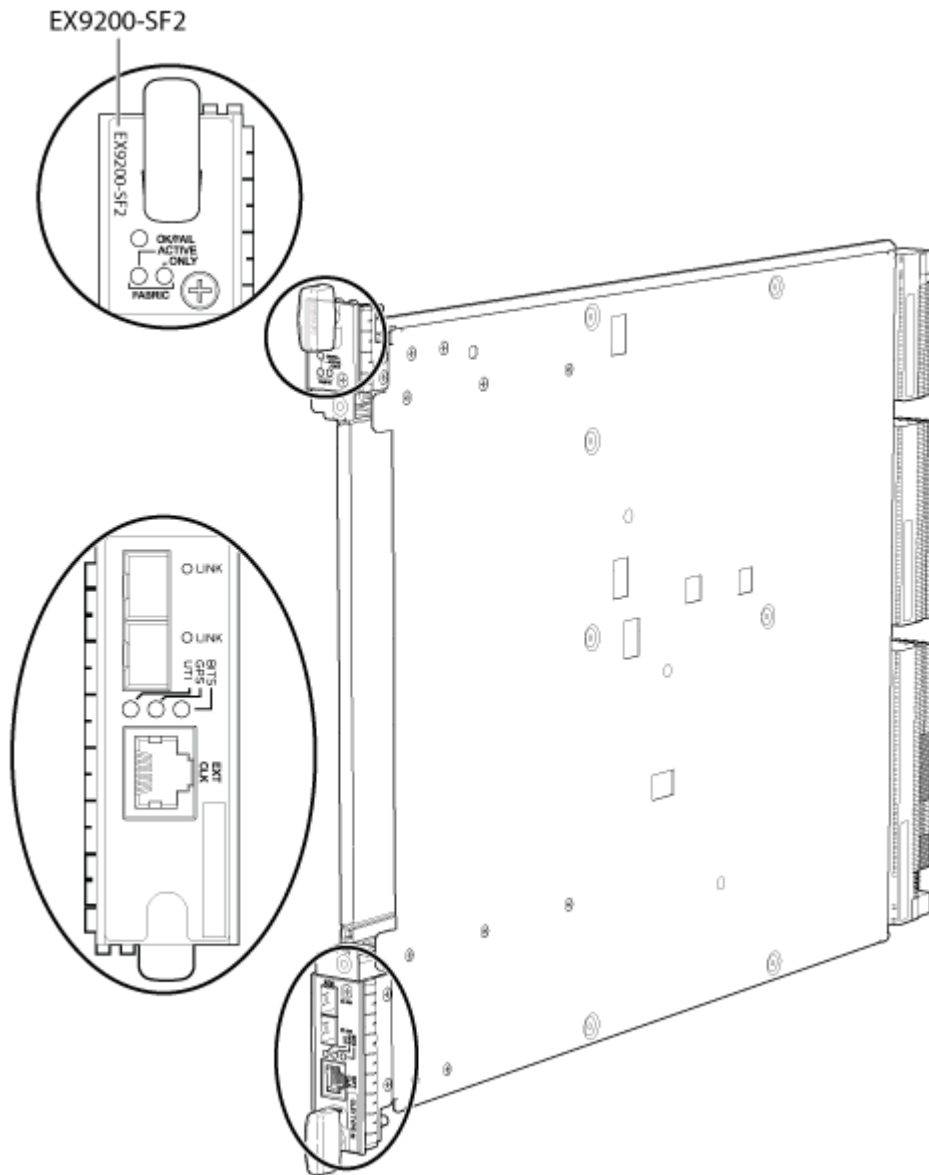

The SF modules install horizontally into the front of the chassis. If any slots are empty, you must install a cover panel.

The SF module has the following components:

- Chassis management Ethernet switch
- I2C bus logic, used for low-level communication with each component
- Component redundancy circuitry
- Control Board/Routing Engine primary-role mechanism

- Gigabit Ethernet switch that is connected to the embedded CPU complex on all components
- Control field-programmable gate array (FPGA)—Provides the Peripheral Component Interconnect (PCI) interface to the Routing Engine
- 1000Base-T Ethernet controller—Provides a 1-Gbps Ethernet link between the Routing Engines
- Ethernet switch—Provides 1-Gbps link speeds between the Routing Engine and the line cards
- External clock interface—Allows BITS or GPS clock source input to the centralized timing circuit, or allows centralized timing to be output to BITS or GPS
- Circuits for chassis management and control
- Power circuits for the Routing Engine and the Switch Fabric
- SF module LEDs—Indicate system status. (See *Switch Fabric Module LEDs in an EX9200 Switch*).
- Ejector levers—Used for installing and removing the SF module
- Captive screws—Secure the SF module in place

SEE ALSO

Installing an SF Module in an EX9200 Switch

Removing an SF Module from an EX9200 Switch

Taking the Host Subsystem Offline in an EX9200 Switch

Switch Fabric Module LEDs in an EX9200 Switch

The Switch Fabric module (SF module) has three LEDs on the module faceplate. [Table 27 on page 78](#) describes the functions of these LEDs. For information about the LEDs on the EX9200-SF3, see [Table 27 on page 78](#).

Table 27: SF Module LEDs of an EX9200 Switch

LED	Status	Description
FABRIC ACTIVE	Green	Switch Fabric is in active mode.

Table 27: SF Module LEDs of an EX9200 Switch (Continued)

LED	Status	Description
	Unlit	Switch Fabric is offline.
FABRIC ONLY	Green	On steadily—Switch Fabric is operating in fabric-only mode.
	Unlit	Switch Fabric is not operating in fabric-only mode.
OK/FAIL	Green	Switch Fabric is online.
	Red	Switch Fabric has failed.
	Unlit	Switch Fabric is offline.

The **BITS**, **GPS**, and **UTI** LEDs, located next to the **EXT CLK** port, indicate the status of the respective clocking interface. These LEDs are not supported.

EX9200-SF3 Module in an EX9200 Switch

IN THIS SECTION

- [EX9200-SF3 Components and Features | 81](#)
- [EX9200-SF3 LEDs | 82](#)
- [EX9200-SF3 Fabric Bandwidth Performance and Redundancy | 83](#)
- [EX9200-SF3 Maximum Power Consumption per Ambient Temperature and CB Slot | 84](#)
- [Interoperability with Existing Hardware | 85](#)
- [EX9200-SF3 Unsupported Functions and Capabilities from Legacy Switch Fabric Modules | 87](#)

Starting in Junos OS Release 20.3R1, the EX9200-SF3 Switch Fabric module is available. The EX9200-SF3 provides improved fabric performance and bandwidth capabilities for high-capacity line cards. In a

redundant configuration, the EX9200-SF3 provides fabric bandwidth of up to 1 Tbps per slot. In a nonredundant configuration the EX9200-SF3 provides fabric bandwidth of up to 1 Tbps per slot (four fabric planes) and 1.5 Tbps per slot fabric bandwidth when all six fabric planes are used (with EX9200-15C line cards).

Figure 30 on page 80 shows the SF module, EX9200-SF3.

Figure 30: EX9200-SF3

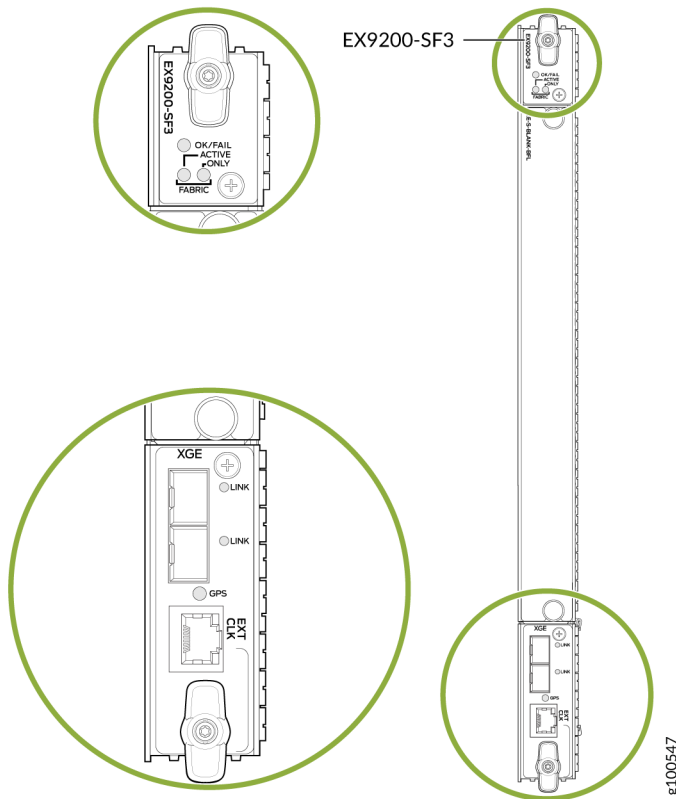

The EX9200-SF3

Software release	Junos OS Release 20.3R1 and later
	Name in CLI: EX9200-SF3

EX9200-SF3 Components and Features

Component/Feature	Description
XGE ports	Two Ethernet ports provide 10GbE and 1GbE SFP+ interfaces. These ports also are connected to the Ethernet control switch, which limits the traffic for the 10GbE port and provides security to prevent unwanted access to the control plane through the external ports.
GPS port	One RJ-45 GPS external clock interface port receives GPS and PPS timing from the GPS external interface. A red LED indicates there is no clock present or the clock is not OK. A green LED indicates the clock interface is active and OK. If the LED is off, the clock interface is not enabled.
External clock interface	The external clock interface is on the EX9200-SF3 front panel. The clock source interface receives GPS and PPS timing from the GPS external interface.
Centralized Stratum3E clock module	The clock module performs clock monitoring, filtering, and holdover on the centralized fabric card. This centralized clocking architecture also provides clock cleanup and distribution.
In-system removable Routing Engine	<p>The in-system Routing Engine can support any new Routing Engine that conforms to the standard modular Routing Engine I/O interface and form factor.</p> <p>NOTE: When a Routing Engine is not installed in the EX9200-SF3, you need to cover the empty slot with a blank panel.</p>
Hot-swappable	<p>The EX9200-SF3 and associated Routing Engine assembly are hot-swappable. The system software provides a mechanism to shut down the Routing Engine/EX9200-SF3. The system software also provides a method to reset or reboot the Routing Engine/EX9200-SF3. This support is provided through CLI commands and various hardware support circuits.</p> <p>NOTE: Before removing the module, you must bring the Routing Engine offline to avoid corrupting the hard drive.</p>
System upgrade capabilities	See <i>Upgrading to an EX9200-SF3</i> for details.

(Continued)

Component/Feature	Description
Redundancy	With three EX9200-SF3 Switch Fabric modules installed, the EX9214 provides 2 + 1 redundancy. With two EX9200-SF3s installed, the EX9204 and EX9208 provide 1 + 1 redundancy.
DMR	Supports dynamic multicast replication (DMR).
GRES	Supports graceful Routing Engine switchover (GRES).
Hitless operation	Allows you to upgrade programmable parts and reboot with “hitless” operation if the redundant EX9200-SF3s are inserted in the system and are operational.
Removable Routing Engine module	You can remove the Routing Engine module FRU in the existing form factor.

EX9200-SF3 LEDs

[Table 28 on page 82](#) describes the functions of the EX9200-SF3 LEDs.

Table 28: EX9200-SF3 Module LEDs

LED	Status	Description
OK/FAIL	Green	Switch Fabric is online.
	Red	Switch Fabric has failed.
	Unlit	Switch Fabric is offline.
FABRIC ACTIVE	Green	Switch Fabric is in active mode.
	Unlit	Switch Fabric is offline.

Table 28: EX9200-SF3 Module LEDs (*Continued*)

LED	Status	Description
FABRIC ONLY	Green	On steadily—Switch Fabric is operating in fabric-only mode.
	Unlit	Switch Fabric is not operating in fabric-only mode.
XGE Port LINK	Green	Port is enabled and a link is established.
	Unlit	Port is disabled or no link is established.
GPS EXT CLK	Green	A link is established.
	Amber (blinking)	There is activity on the clocking interface.

EX9200-SF3 Fabric Bandwidth Performance and Redundancy

EX9214 Switches:

- The EX9214 system can contain up to three EX9200-SF3s to provide a total of six switch fabric planes for packet forwarding among the MPCs. Two fabric planes per EX9200-SF3s are required. To achieve full fabric bandwidth performance, three EX9200-SF3s must be installed in the EX9214 chassis.
- Two chassis slots are provided in the center of the EX9214 chassis in slots 6 and 7 (also designated as slot SF0 and slot SF1) for two EX9200-SF3s, each equipped with a Routing Engine.
- To provide 2 + 1 fabric redundancy for an EX9214, a third EX9200-SF3 must be installed in slot 8 (also designated as slot SF2).
- Slot 8 in the EX9214 chassis is a dual-purpose slot, and supports either an EX9200-SF3 or a line card. When the EX9200-SF3/Routing Engine are plugged into slot 8, the Routing Engine is powered down and does not provide any control functionality for the board or the EX9214. The fabric-only LED on the card faceplate will be lit when an EX9200-SF3/Routing Engine assembly is plugged into slot 8.
- Once redundancy is configured, the primary EX9200-SF3 controls the chassis.
- Graceful upgrades can be achieved on a non-primary redundant EX9200-SF3.

- In a redundant configuration, the non-primary redundant Routing Engine can be removed or installed without affecting the switching plane functionality on the EX9200-SF3 in which it resides.
- In a nonredundant configuration, all six fabric planes will be in active mode for increased fabric bandwidth.
- There is one physical switch fabric per EX9200-SF3 and it acts as two virtual planes in the EX9214.

EX9204 and EX9208 Switches:

- You can install either one or two EX9200-SF3s in the EX9204 and EX9208 chassis in the slots labeled 0 and 1.
- The EX9200-SF3 in slot 0 (SF0) provides two fabric planes; the EX9200-SF3 in slot 1 (SF1) provides four fabric planes. A total of six fabric planes are available in the EX9204 and EX9208.
- In a redundant configuration, two fabric planes on the first EX9200-SF3 and two fabric planes on the other EX9200-SF3 will be in active mode.
- There is one physical switch fabric per EX9200-SF3, and it acts as four virtual planes in the EX9204 and EX9208.

Two EX9200-SF3 modules installed in the EX9204 and EX9208 are required for 1 + 1 redundancy. To provide 1 + 1 fabric redundancy, there must be an EX9200-SF3 installed in slot 1.

NOTE:

- If SF0 fails, SF1 will be automatically configured with four fabric planes active. In this failover scenario, the EX9200-SF3 will support full line rate 100 percent redundancy.
- If SF1 fails, SF0 has only two available fabric planes; therefore, in this failover mode, the line rate will drop to 50 percent.

EX9200-SF3 Maximum Power Consumption per Ambient Temperature and CB Slot

NOTE: These power consumption values are for the EX9200-SF3 only. They do not include reallocated power.

EX Series Model	Ambient Temperature	Maximum Power Consumption	Slot
EX9214	131° F (55° C)	425 W	SF0, SF1, SF2
	104° F (40° C)	400 W	
	77° F (25° C)	385 W	
EX9208	131° F (55° C)	295 W	SF0 (primary)
	104° F (40° C)	280 W	
	77° F (25° C)	265 W	
EX9208	131° F (55° C)	295 W	SF1 (backup)
	104° F (40° C)	280 W	
	77° F (25° C)	265 W	
EX9204	131° F (55° C)	275 W	SF0 (primary)
	104° F (40° C)	260 W	
	77° F (25° C)	245 W	
EX9204	131° F (55° C)	295 W	SF1 (backup)
	104° F (40° C)	280 W	
	77° F (25° C)	265 W	

Interoperability with Existing Hardware

Table 29: EX9200-SF3 Interoperability with Line Cards and Routing Engines

EX9200-SF3 Operating Mode	EX9204/EX9208/EX9214	Supported
Enhanced IP/enhanced Ethernet mode only	EX9200-2C-8XS	No
	EX9200-4QS	No

Table 29: EX9200-SF3 Interoperability with Line Cards and Routing Engines (*Continued*)

EX9200-SF3 Operating Mode	EX9204/EX9208/EX9214	Supported
	EX9200-6QS	No
	EX9200-MPC	Yes
	EX9200-12QS	Yes
	EX9200-15C	Yes
	EX9200-32XS	Yes
	EX9200-40T	No
	EX9200-40F	No
	EX9200-40F-M	No
	EX9200-40XS	Yes
Supported Routing Engines	EX9200-RE	Yes
	EX9200-RE2	Yes

NOTE: Hyper-mode is the default forwarding mode on the EX9200-SF3. If your deployment does not need hyper-mode, disable hyper-mode using the `set forwarding-options no-hyper-mode` CLI command before installing the Routing Engine into the EX9200-SF3.

NOTE: Enhanced IP is the default network service on the EX9200-SF3.

EX9200-SF3 Unsupported Functions and Capabilities from Legacy Switch Fabric Modules

- The EX9200-SF3 does not support the external UTI/DTI interface (front panel LED and daughter card interface).
- The EX9200-SF3 does not interoperate with any previous generation SF modules (EX9200-SF and EX9200-SF2). Smooth upgrade is not supported.
- The EX9200-SF3 does not support BITS.
- The EX9200-SF3 does not support DPCs.
- The EX9200-SF3 does not support mixed mode (DPC + MPC).
- The EX9200-SF3 does not support the JAM release.

SEE ALSO

Upgrading to an EX9200-SF3

Installing an SF Module in an EX9200 Switch

Removing an SF Module from an EX9200 Switch

Taking the Host Subsystem Offline in an EX9200 Switch

EX9200 Line Cards

IN THIS SECTION

- [Line Card Model and Version Compatibility in an EX9200 Switch | 88](#)
- [EX9200-2C-8XS Line Card | 91](#)
- [EX9200-4QS Line Card | 93](#)
- [EX9200-6QS Line Card | 94](#)
- [EX9200-MPC Line Card | 97](#)
- [EX9200-12QS Line Card | 101](#)
- [EX9200-15C Line Card | 103](#)

- [EX9200-32XS Line Card | 107](#)
- [EX9200-40T Line Card | 108](#)
- [EX9200-40F Line Card | 110](#)
- [EX9200-40F-M Line Card | 112](#)
- [EX9200-40XS Line Card | 114](#)
- [Line Card LED in an EX9200 Switch | 115](#)
- [Network Port LEDs on Line Cards in an EX9200 Switch | 116](#)
- [Modular Interface Card LED in an EX9200 Switch | 118](#)
- [Configuring Rate Selectability on an EX9200-12QS Line Card to Enable Different Port Speeds | 118](#)

Line Card Model and Version Compatibility in an EX9200 Switch

NOTE: If you are installing line cards released after Junos OS Release 14.1, ensure that the Switch Fabric module (SF module) EX9200-SF2 is installed in the switch chassis.

[Table 30 on page 88](#) shows the model numbers, description of the line card, the Junos OS release in which the line card was first supported and the Switch Fabric module (SF module) that must be installed in the switch to support each line card.

Table 30: Line Card Models for EX9200 Switches

Model number	Description	First Junos OS Release	SF Module Required
EX9200-2C-8XS	A line card with two 100-Gigabit Ethernet ports and eight 10-Gigabit Ethernet ports <i>See EX9200-2C-8XS Line Card</i>	13.2R1	EX9200-SF or EX9200-SF2
EX9200-4QS	A line card with four 40-Gigabit Ethernet ports <i>See EX9200-4QS Line Card</i>	12.3R2	EX9200-SF or EX9200-SF2

Table 30: Line Card Models for EX9200 Switches (Continued)

Model number	Description	First Junos OS Release	SF Module Required
EX9200-6QS	<p>A line card with six 40-Gigabit Ethernet ports and 24 10-Gigabit Ethernet ports</p> <p>See <i>EX9200-6QS Line Card</i></p>	<p>14.2R1</p> <p>CAUTION: Junos OS Release 14.2R1 supports the EX9200-6QS line card except for one specific configuration. See the Junos OS 14.2R2 Release Notes for Known Issue PR1068396 to determine whether that configuration applies to your switch and which release to use if the configuration applies.</p>	EX9200-SF or EX9200-SF2
EX9200-MPC	<p>A modular line card that accepts any of the following MICs:</p> <ul style="list-style-type: none"> • EX9200-10XS-MIC • EX9200-20F-MIC • EX9200-40T-MIC <p>See <i>EX9200-MPC Line Card</i></p>	15.1R3	EX9200-SF, EX9200-SF2, or EX9200-SF3
EX9200-12QS	<p>A line card with 12 40-Gigabit Ethernet rate-selectable ports, each of which can house transceivers</p> <p>See <i>EX9200-12QS Line Card</i></p>	16.1R1	EX9200-SF2 or EX9200-SF3

Table 30: Line Card Models for EX9200 Switches (Continued)

Model number	Description	First Junos OS Release	SF Module Required
EX9200-15C	A line card with 15 rate-selectable ports. All ports can operate at 10-Gbps, 25-Gbps, 40-Gbps, or 100-Gbps speeds See <i>EX9200-15C Line Card</i>	20.3R1	EX9200-SF3
EX9200-32XS	A line card with 32 10-Gigabit Ethernet ports See <i>EX9200-32XS Line Card</i>	12.3R2	EX9200-SF, EX9200-SF2, or EX9200-SF3
EX9200-40T	A line card with 40 10/100/1000BASE-T ports that support RJ-45 connectors See <i>EX9200-40T Line Card</i>	12.3R2	EX9200-SF or EX9200-SF2
EX9200-40F	A line card with 40 1-Gigabit Ethernet ports See <i>EX9200-40F Line Card</i>	12.3R2	EX9200-SF or EX9200-SF2
EX9200-40F-M	A line card with 40 1-Gigabit Ethernet ports with Media Access Control Security (MACsec) capability See <i>EX9200-40F-M Line Card</i>	14.2R1	EX9200-SF or EX9200-SF2
EX9200-40XS	A line card with 40 10-Gigabit Ethernet ports with Media Access Control Security (MACsec) capability, each of which can house 10-gigabit small form-factor pluggable plus (SFP+) transceivers See <i>EX9200-40XS Line Card</i>	16.1R1	EX9200-SF2 or EX9200-SF3

Ensure that all of the line cards in a switch are supported in the Junos OS release that you want to use.

EX9200-2C-8XS Line Card

IN THIS SECTION

- [Line Card Models | 91](#)
- [Line Card Components | 92](#)

The line cards in EX9200 switches combine a Packet Forwarding Engine and Ethernet interfaces in a single assembly. Line cards are field-replaceable units (FRUs) that you can install in the line card slots on the front of the switch chassis. Line cards are hot-insertable and hot-removable: You can remove and replace them without powering off the switch or disrupting switch functions.

Line Card Models

[Table 31 on page 91](#) shows the model number, description of the line card model, and the Junos OS release in which the line card was first supported.

Table 31: EX9200-2C-8XS Line Card

Model	Description	Junos OS Release Required
EX9200-2C-8XS	A line card with two 100-Gigabit Ethernet ports, each of which can house 100-gigabit C form-factor pluggable (CFP) transceivers; and eight 10-Gigabit Ethernet ports, each of which can house 10-gigabit small form-factor pluggable plus (SFP+) transceivers	13.2R1 or later

See [Figure 31 on page 92](#)

Figure 31: EX9200-2C-8XS Line Card

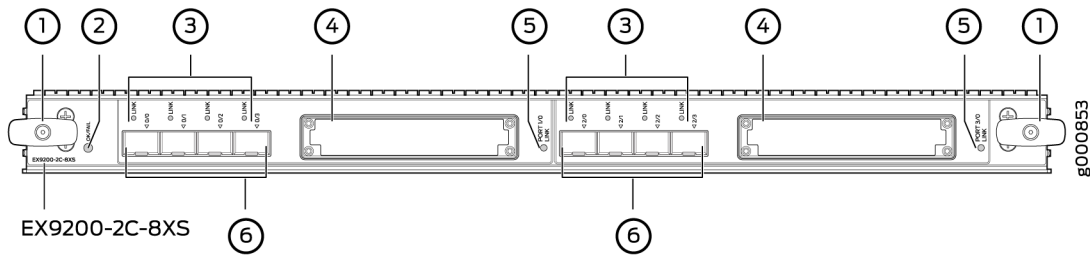

1– Ejector levers	4– 100-Gigabit Ethernet ports
2– Line card LED	5– LEDs for the 100-Gigabit Ethernet ports
3– LEDs for the 10-Gigabit Ethernet ports	6– 10-Gigabit Ethernet ports

You can use the `show version` command to see the version of Junos OS for EX Series switches loaded on the switch.

Line Card Components

The EX9200-2C-8XS line card has:

- Two 100-Gigabit Ethernet ports, each of which can house CFP transceivers. These ports support 100GBASE-LR4 and 100GBASE-SR10 transceivers.
- Eight 10-Gigabit Ethernet ports, each of which can house SFP+ transceivers. These ports support 10GBASE-SR, 10GBASE-LR, 10GBASE-ER, and 10GBASE-ZR transceivers.
- Two dust covers for the two 100-Gigabit Ethernet ports and eight dust covers for the eight 10-Gigabit Ethernet ports
- Line card LED—An LED labeled **OK/FAIL**, which indicates the status of the line card. See *Line Card LED in an EX9200 Switch*.
- LEDs for the ports—One LED on each port, the Link/Activity LED, which indicates the link status and activity on the port. See *Network Port LEDs on Line Cards in an EX9200 Switch*.

The ports are divided into two port groups. The four 10-Gigabit Ethernet ports labeled **0/0** through **0/3** and the 100-Gigabit Ethernet port labeled **1/0** form one port group. The four 10-Gigabit Ethernet ports labeled **2/0** through **2/3** and the 100-Gigabit Ethernet port labeled **3/0** form the other port group. The ports in each group share 130 gigabits of bandwidth. Thus, you can transmit up to 130 gigabits of traffic through a port group, without packet drop.

EX9200-4QS Line Card

IN THIS SECTION

- [Line Card Models | 93](#)
- [Line Card Components | 94](#)

The line cards in EX9200 switches combine a Packet Forwarding Engine and Ethernet interfaces on a single assembly. They are field-replaceable units (FRUs) that you can install in the line card slots on the front of the switch chassis. Line cards are hot-insertable and hot-removable: You can remove and replace them without powering off the switch or disrupting switch functions.

Line Card Models

[Table 32 on page 93](#) shows the model number, description of the line card model, and the Junos OS release in which the line card was first supported.

Table 32: EX9200-4QS Line Card

Model	Description	Junos OS Release Required
EX9200-4QS	A line card with four 40-Gigabit Ethernet ports, each of which can house 40-gigabit quad small form-factor pluggable plus (QSFP+) transceivers	12.3R2 or later

See [Figure 32 on page 93](#).

Figure 32: EX9200-4QS Line Card

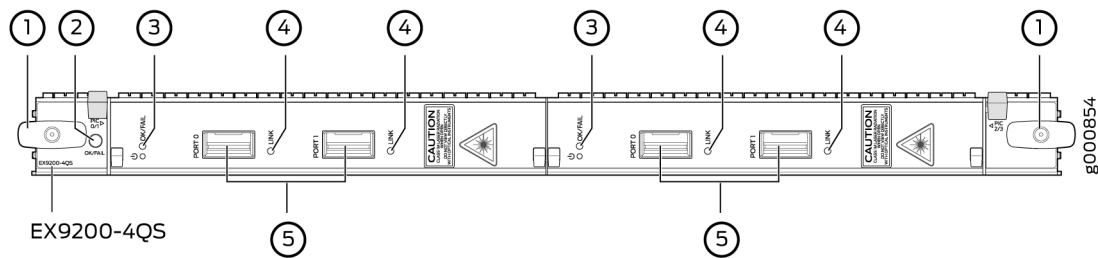

1– Ejector lever	4– LEDs for the ports
2– Line card LED	5– 40-Gigabit Ethernet ports
3– MIC LED	

You can use the `show version` command to see the version of Junos OS for EX Series switches loaded on the switch.

Line Card Components

The EX9200-4QS line card has:

- Four 40-Gigabit Ethernet ports, each of which can house QSFP+ transceivers.
- Four dust covers preinstalled in the ports.
- Line card LED—An LED labeled **OK/FAIL**, which indicates the status of the line card. See *Line Card LED in an EX9200 Switch*.
- MIC LED—An LED labeled **OK/FAIL** on each MIC, which indicates the status of the MIC. See *Modular Interface Card LED in an EX9200 Switch*.
- LEDs for the ports—One LED on each port, the Link/Activity LED, which indicates the link status and activity on the port. See *Network Port LEDs on Line Cards in an EX9200 Switch*.

EX9200-6QS Line Card

IN THIS SECTION

- [Line Card Models | 95](#)
- [Line Card Components | 95](#)

The line cards in EX9200 switches combine a Packet Forwarding Engine and Ethernet interfaces in a single assembly. Line cards are field-replaceable units (FRUs) that you can install in the line card slots on the front of the switch chassis. Line cards are hot-insertable and hot-removable: You can remove and replace them without powering off the switch or disrupting switch functions.

Line Card Models

Table 33 on page 95 shows the model number, description of the line card model, and the Junos OS release in which the line card was first supported.

Table 33: EX9200-6QS Line Card

Model	Description	Junos OS Release Required
EX9200-6QS	A line card with six 40-Gigabit Ethernet ports, each of which can house 40-gigabit quad small form-factor pluggable plus (QSFP+) transceivers; and 24 10-Gigabit Ethernet ports, each of which can house 10-gigabit small form-factor pluggable (SFP+) transceivers	14.2R1 or later CAUTION: Junos OS Release 14.2R1 supports the EX9200-6QS line card except for one specific configuration. See the Junos OS 14.2R2 Release Notes for Known Issue PR1068396 to determine whether that configuration applies to your switch and which release to use if the configuration does apply.

See Figure 33 on page 95.

Figure 33: EX9200-6QS Line Card

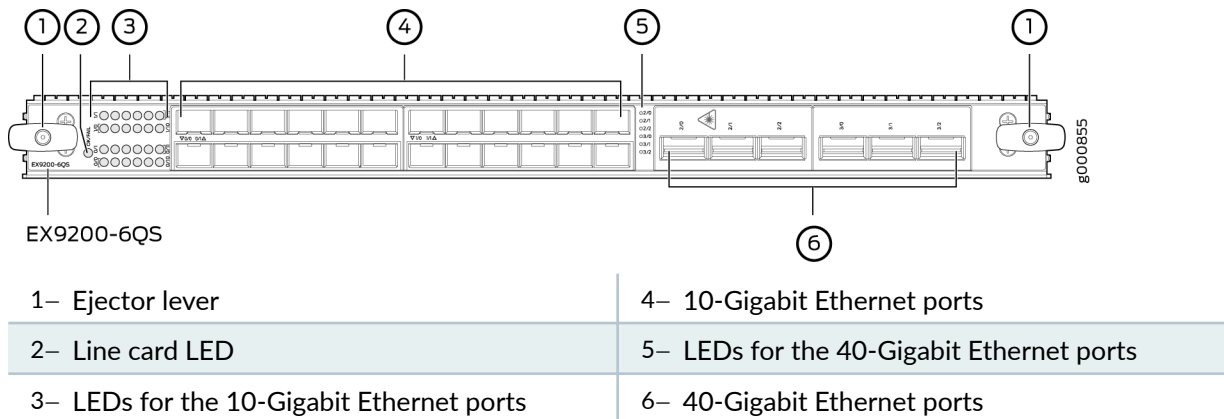

You can use the `show version` command to see the version of Junos OS for EX Series switches loaded on the switch.

Line Card Components

The EX9200-6QS line card has:

- Six 40-Gigabit Ethernet ports, each of which can house QSFP+ transceivers. These ports support 40GBASE-LR4 and 40GBASE-SR4 transceivers. Starting with Junos OS for EX Series switches, Release 15.1 R3, these ports support the JNP-QSFP-40G-LX4 transceiver.
- 24 10-Gigabit Ethernet ports, each of which can house SFP+ transceivers. These ports support 10GBASE-SR, 10GBASE-LR, 10GBASE-ER, and 10GBASE-ZR transceivers.
- Line card LED—An LED labeled **OK/FAIL**, which indicates the status of the line card. See *Line Card LED in an EX9200 Switch*.
- Network port LED—One LED on each network port, the Link/Activity LED, which indicates the link status and activity on the port. See *Network Port LEDs on Line Cards in an EX9200 Switch*.

You can install SFP+ and QSFP+ transceivers in any combination in the ports on the line card. The ports are divided into two port groups. The twelve 10-Gigabit Ethernet ports labeled **0/0** through **0/11** form PIC 0 and twelve 10-Gigabit Ethernet ports labeled **1/0** through **1/11** form PIC 1; PIC 0 and PIC 1 form one port group. The three 40-Gigabit Ethernet ports labeled **2/0** through **2/2** form PIC 2 and three 40-Gigabit Ethernet ports labeled **3/0** through **3/2** form PIC 3; PIC 2 and PIC 3 form the other port group. The ports in each port group share 240 gigabits of bandwidth. Thus, you can transmit up to 240 gigabits of traffic through a port group, without packet drop.

PIC 0 and PIC 1 are activated by default. If you deactivate both PIC 0 and PIC 1, PIC 2 and PIC 3 are automatically activated. Similarly, if you deactivate both PIC 2 and PIC 3, PIC 0 and PIC 1 are automatically activated. You can choose to activate only one of the PICs and keep the other inactive. To deactivate an active PIC, use the [power](#) command.

The line card supports the following combinations of active PICs:

- Any one PIC
- PIC 0 and PIC 1
- PIC 0 and PIC 3
- PIC 1 and PIC 2
- PIC 2 and PIC 3

NOTE: The line card does not support the following combinations of active PICs:

- PIC 0 and PIC 2
- PIC 1 and PIC 3

EX9200-MPC Line Card

IN THIS SECTION

- [Line Card Models | 97](#)
- [Line Card Components | 99](#)

Line Card Models

[Table 34 on page 98](#) shows the model number, description of the line card model, and the Junos OS release in which the line card was first supported.

Table 34: EX9200-MPC

Model	Description	Junos OS Release Required
EX9200-MPC	<p>A modular line card that accepts any of the following Modular Interface Cards (MICs):</p> <ul style="list-style-type: none"> • EX9200-10XS-MIC • EX9200-20F-MIC • EX9200-40T-MIC <p>The MICs are separately orderable.</p> <p>The EX9200-MPC line card has two slots on the faceplate in which you can install the MICs. You can install the MICs in the following configurations:</p> <ul style="list-style-type: none"> • One EX9200-10XS-MIC • One EX9200-20F-MIC • One EX9200-10XS-MIC and one EX9200-20F-MIC • Two EX9200-10XS-MICs • Two EX9200-20F-MICs • One EX9200-40T-MIC <p>You can transmit up to 130 gigabits of traffic through the line card without packet drop.</p>	15.1R3

See [Figure 34 on page 98](#).

Figure 34: EX9200-MPC Line Card

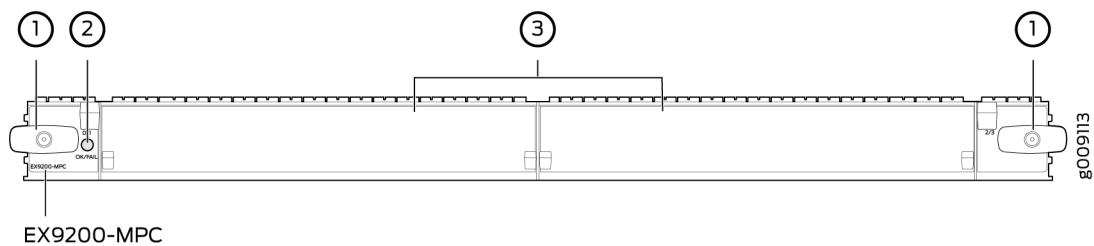

1– Ejector lever	3– MIC slots covered by cover panels
2– Line card LED	

You can use the `show version` command to see the version of Junos OS for EX Series switches loaded on the switch.

Line Card Components

The EX9200-MPC line card has:

- Two slots that can accept any of the following MICs:
 - EX9200-10XS-MIC, which has ten 10-Gigabit Ethernet ports, each of which can house small form-factor pluggable plus (SFP+) transceivers. The ports form one port group. The ports support 10GBASE-SR, 10GBASE-LR, 10GBASE-ER, and 10GBASE-ZR transceivers. An LED labeled **OK/FAIL** on the MIC indicates the status of the MIC. See *Modular Interface Card LED in an EX9200 Switch*. The MIC is shipped with 10 dust covers for the 10 ports. See [Figure 35 on page 99](#).

Figure 35: EX9200-10XS-MIC

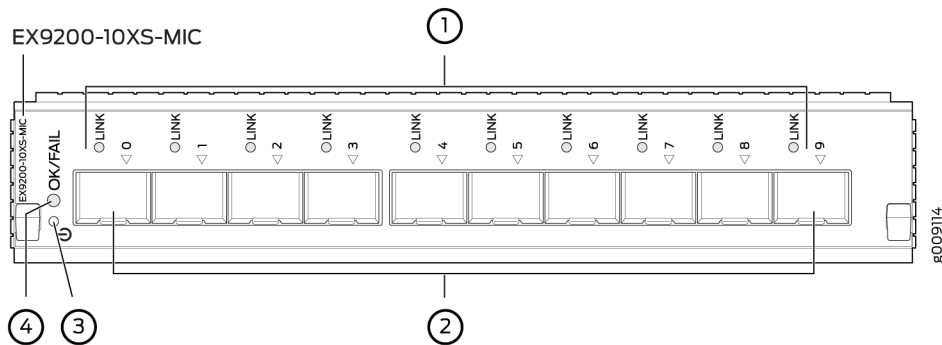

1– LEDs for the ports	3– MIC power button
2– 10-Gigabit Ethernet ports	4– MIC LED

- EX9200-20F-MIC, which has twenty 1-Gigabit Ethernet ports with Media Access Control Security (MACsec) capability, each of which can house 1-gigabit small form-factor pluggable (SFP) transceivers. The EX9200-20F-MIC in EX9200-MPC line card supports 802.1AE IEEE MAC Security standard (also known as MACsec) with AES-128 bit encryption, providing support for link-layer data confidentiality, data integrity, and data origin authentication. You must apply a single license—EX9200-SFL—to enable MACsec. The ports are divided into two port groups of ten ports each. The ports labeled [0/2]/0 through [0/2]/8 and [1/3]/0 through [1/3]/8 form one port group and the ports labeled [0/2]/1 through [0/2]/9 and [1/3]/1 through [1/3]/9 form another port group. These ports support 1000BASE-T, 1000BASE-SX, 100BASE-FX, 1000BASE-LX, 1000BASE-BX-U, 1000BASE-BX-D, 100BASE-BX-U, 100BASE-BX-D, and 1000BASE-LH

transceivers. An LED labeled **OK/FAIL** on the MIC indicates the status of the MIC. See *Modular Interface Card LED in an EX9200 Switch*. The MIC is shipped with 20 dust covers for the 20 ports. See [Figure 36 on page 100](#).

Figure 36: EX9200-20F-MIC

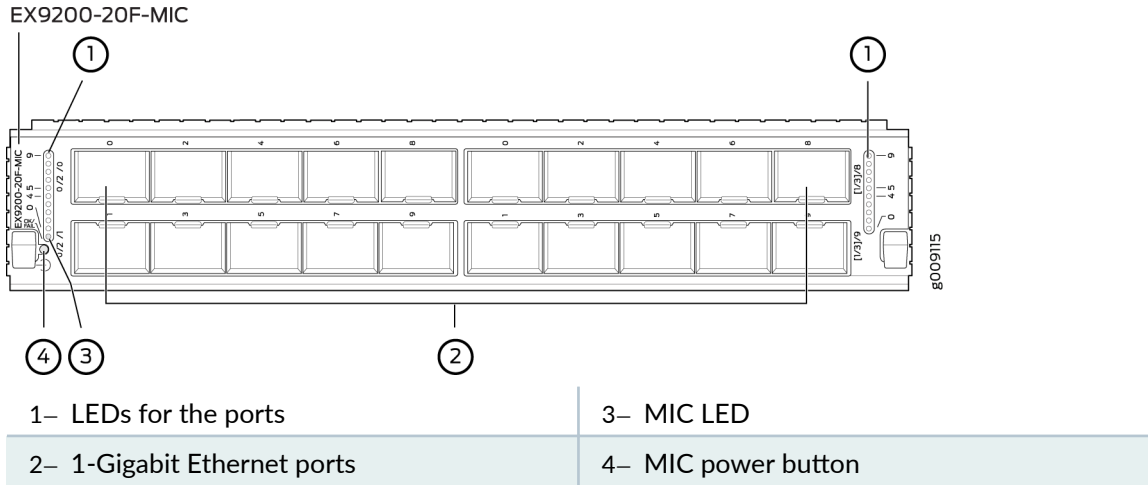

- EX9200-40T-MIC, which has 40 RJ-45 ports, which can accept RJ-45 connectors. The ports are divided into three port groups. The ports labeled **0/1** through **1/5** and **0/0** through **1/4** form port group pic0, the ports labeled **1/7** through **2/3** and **1/6** through **2/2** form port group pic1, and the ports labeled **2/5** through **3/9** and **2/4** through **3/8** form port group pic2. An LED labeled **OK/FAIL** on the MIC indicates the status of the MIC. See *Modular Interface Card LED in an EX9200 Switch*. See [Figure 37 on page 100](#).

Figure 37: EX9200-40T-MIC

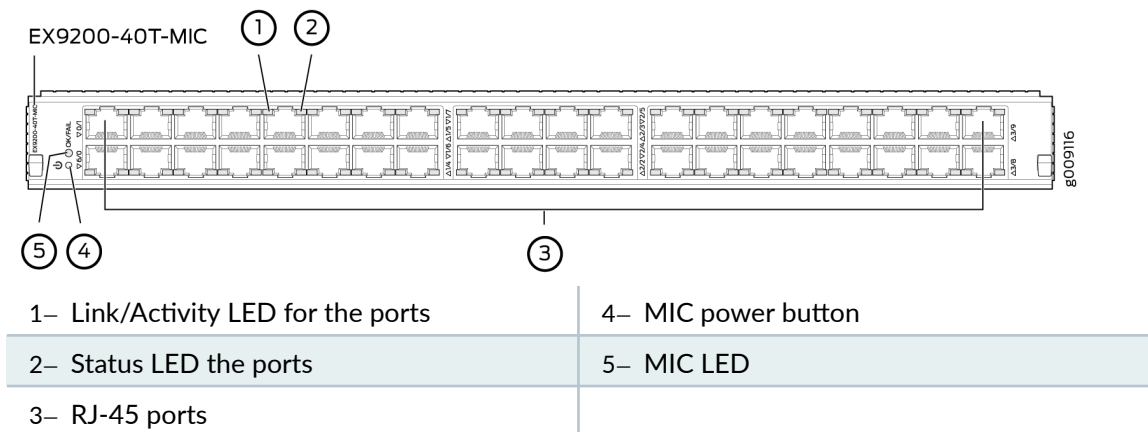

- Cover panels—Two cover panels that cover the MIC slots.

- Line card LED—An LED labeled **OK/FAIL**, which indicates the status of the line card. See *Line Card LED in an EX9200 Switch*.
- Network port LEDs—Each port on the EX9200-10XS-MIC and each port on the EX9200-20F-MIC has an LED, the Link/Activity LED, which indicates the link status and activity on the port. Each port on the EX9200-40T-MIC has another LED, the Status LED, which indicates the status of the port parameters. See *Network Port LEDs on Line Cards in an EX9200 Switch*.

EX9200-12QS Line Card

IN THIS SECTION

- [Line Card Models | 101](#)
- [Line Card Components | 102](#)

The line cards in EX9200 switches combine a Packet Forwarding Engine and Ethernet interfaces in a single assembly. Line cards are field-replaceable units (FRUs) that you can install in the line card slots on the front of the switch chassis. Line cards are hot-insertable and hot-removable: You can remove and replace them without powering off the switch or disrupting switch functions.

Line Card Models

[Table 35 on page 101](#) shows the model number, description of the line card model, and the Junos OS release in which the line card was first supported.

Table 35: EX9200-12QS Line Card

Model	Description	Junos OS Release Required
EX9200-12QS	A line card with 12 rate-selectable ports, each of which can house transceivers. All ports can operate at 10-Gbps and 40-Gbps speeds. The ports are configured to operate at 10-Gbps speed by default. The ports labeled 0/2 , 0/5 , 1/2 , and 1/5 (see Figure 38 on page 102) can operate at 100-Gbps speed also. The line card supports maximum transmission units (MTUs) from 256 bytes through 9192 bytes.	16.1R1 or later

Table 35: EX9200-12QS Line Card (Continued)

Model	Description	Junos OS Release Required
-------	-------------	---------------------------

NOTE: For the EX9200-12QS line card to be operational, you must install the EX9200-SF2 Switch Fabric module (SF module) in the switch. See *Switch Fabric Module in an EX9200 Switch* and *Installing an SF Module in an EX9200 Switch*.

Figure 38 on page 102 shows the components of an EX9200-12QS line card.

Figure 38: EX9200-12QS Line Card

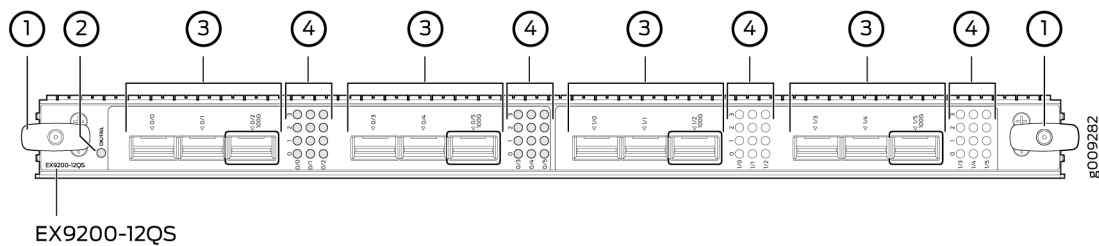

1– Ejector lever	3– 10G/40G/100G Ethernet ports
2– Line card LEDs	4– Link/Activity LEDs for the 10G/40G/100G Ethernet ports

You can use the `show version` command to see the version of Junos OS for EX Series switches loaded on the switch.

Line Card Components

The EX9200-12QS line card has:

- Twelve rate-selectable Gigabit Ethernet ports. All ports can operate at 10-Gbps and 40-Gbps speeds. The ports are configured to operate at 10-Gbps speed by default. The ports labeled **0/2**, **0/5**, **1/2**, and **1/5** (see Figure 38 on page 102) can operate at 100-Gbps speed also. You can configure the port speed by using the following command:

```
user@host# set chassis fpc fpc-slot pic pic-number pic-mode pic-speed number of ports number-of-active-physical-ports
```

- You can configure a port to operate at 10-Gbps speed. If you configure the ports to operate at 10-Gbps speed, each port operates as four 10-Gbps interfaces.

- You can configure a port to operate at 40-Gbps speed and install a 40-gigabit QSFP+ transceiver in the port.
- You can configure the ports labeled **0/2**, **0/5**, **1/2**, and **1/5** (see [Figure 38 on page 102](#)) to operate at 100-Gbps speed and install 100-gigabit QSFP+ transceivers in these ports.
- Twelve dust covers for the ports
- Line card LED—An LED labeled **OK/FAIL**, which indicates the status of the line card. See *Line Card LED in an EX9200 Switch*.
- Network port LED—Four LEDs for each network port, the Link/Activity LED, which indicates the link status and activity on the port. See *Network Port LEDs on Line Cards in an EX9200 Switch*.

There are four LEDs labeled **0**, **1**, **2**, and **3** for each port (see [Figure 38 on page 102](#)). If a port is configured to operate at 10-Gbps speed, four 10-Gbps interfaces are created and the LEDs labeled **0**, **1**, **2**, and **3** for that port becomes operational. Each of these LEDs indicates the link/activity on each interface on the corresponding port. If a port is configured to operate at 40-Gbps speed, the LED labeled **0** for that port becomes operational. If the ports labeled **0/2**, **0/5**, **1/2**, and **1/5** are configured to operate at 100-Gbps speed, the LED labeled **3** for each of these ports becomes operational.

You can find the list of transceivers supported on the EX9200-12QS line card at the [Hardware Compatibility Tool page for the EX9200-12QS line card](#).

The ports are divided into two port groups. The six ports labeled **0/0** through **0/5** form one port group, PIC 0. The six ports labeled **1/0** through **1/5** form the other port group, PIC 1. The ports in each group share 240 gigabits of bandwidth. Thus, you can transmit up to 240 gigabits of traffic through a port group without packet drop.

EX9200-15C Line Card

IN THIS SECTION

- [Line Card Models | 104](#)
- [Line Card Components | 105](#)
- [EX9200-15C Power Requirements | 106](#)
- [EX9200-15C LEDs | 106](#)
- [Cables and Connectors | 107](#)

The line cards in EX9200 switches combine a Packet Forwarding Engine and Ethernet interfaces in a single assembly. Line cards are field-replaceable units (FRUs) that you can install in the line card slots on the front of the switch chassis. Line cards are hot-insertable and hot-removable: You can remove and replace them without powering off the switch or disrupting switch functions.

Line Card Models

Table 36 on page 104 shows the model number, description of the line card model, and the Junos OS release in which the line card was first supported.

Table 36: EX9200-15C Line Card

Model	Description	Junos OS Release Required	Name In the CLI
EX9200-15C	<ul style="list-style-type: none"> Fixed-configuration line card with 15 rate-selectable ports. All ports can operate at 10-Gbps, 25-Gbps, 40-Gbps, or 100-Gbps speeds. The ports are configured to operate at 100-Gbps speed by default. Line-rate throughput of up to 1.5 Tbps when installed with an enhanced midplane. <ul style="list-style-type: none"> NOTE: In the CLI, when you run the <code>show chassis hardware</code> command, the midplane description will say <code><platform>-BP3</code> for an enhanced midplane. The EX9214 only uses enhanced midplanes. Line-rate throughput of up to 800 Gbps when installed with a standard midplane. <ul style="list-style-type: none"> NOTE: In the CLI, when you run the <code>show chassis hardware</code> command, the midplane description will say <code><platform>-BP</code> for a standard midplane. Supports maximum transmission units (MTUs) from 256 bytes through 16,000 bytes for transit traffic, and from 256 bytes through 9500 bytes for host-bound packets. 	20.3R1 or later	EX9200-15C

NOTE:

- For the EX9200-15C line card to be operational, you must install the EX9200-SF3 Switch Fabric module (SF module) in the switch. See *EX9200-SF3 Module in an EX9200 Switch*.
- To achieve maximum line-rate performance, the line card's fabric redundancy mode must be configured in increased bandwidth mode.
- To achieve maximum performance, the following number of EX9200-SF3 SF modules must be installed in the system:
 - EX9214—Three EX9200-SF3 SF modules
 - EX9204 and EX9208—Two EX9200-SF3 SF modules

Figure 39 on page 105 shows the components of an EX9200-15C line card.

Figure 39: EX9200-15C Line Card

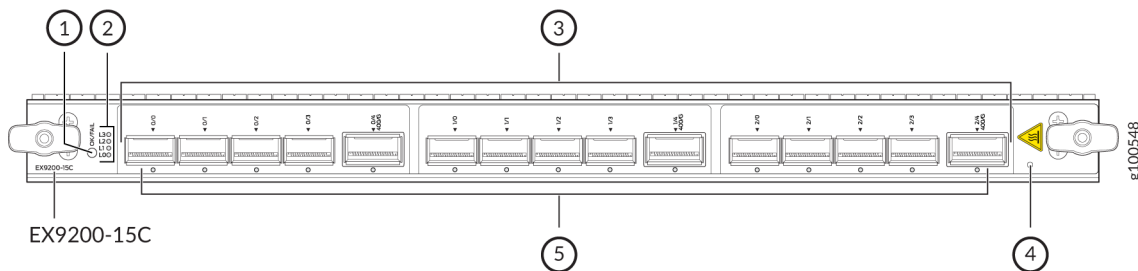

1– OK/FAIL LED

2– Lane LEDs

3– Network ports

4– Physical Presence button

5– Port LEDs

You can use the `show version` command to see the version of Junos OS for EX Series switches loaded on the switch.

Line Card Components

The EX9200-15C line card has:

- Fifteen network ports that can be configured for 10-Gbps, 25-Gbps, 40-Gbps, or 100-Gbps (breakout cables are used for 10-Gbps and 25-Gbps speeds).
- The Switch Processor Mezzanine Board (SPMB) consists of a 1.6-GHz Intel Broadwell 8-core CPU, 100-GB SATA SSD, and two 16-GB ECC DDR4 DRAM modules.
- Three Packet Forwarding Engines, each providing a maximum bandwidth of 500 Gbps.

- Juniper Trio 5 silicon for increased scaling for bandwidth, subscribers, and services.

NOTE: On EX9214 switches, the EX9200-15C is not supported in the line-card slots numbered 0, 1, and 11.

EX9200-15C Power Requirements

The power numbers are measured using the following configuration:

- IPv4 forwarding with 200-bytes packet size
- Line-rate traffic on all ports for 1.5-Tbps aggregate bandwidth
- All 15 ports are configured for 100GbE, with QSFP28 LR4 transceivers installed on all ports

At different temperatures:

- 104° F (40° C): 785 W
- 77° F (25° C): 720 W

EX9200-15C LEDs

OK/FAIL LED, one bicolor:

- Green—MPC is functioning normally.
- Red—MPC has failed.

Port LED:

- Off—Port link is down with loss of signal.
- Green—Port link is up with no alarms or failures.
- Amber—Port link is down with alarms. Or the port has been administratively disabled through the CLI.
- Red—A transceiver on the port is experiencing a fault.

Lane LED:

There are four Lane LEDs, which are shared by the network ports. The Lane LEDs work with the Junos OS software to determine which port the Lane LEDs are displaying the status for.

The Lane LEDs are used for the following configurations:

- When a network port is configured for 4 x 10GbE channelized interfaces with a breakout cable.
- When a network port is configured for 4 x 25GbE channelized interfaces with a breakout cable.

Cables and Connectors

You can use the [Hardware Compatibility Tool](#) to find information about the pluggable transceivers supported on your Juniper Networks device.

The list of supported transceivers for the EX Series is located at [EX Series Supported Transceivers](#).

EX9200-32XS Line Card

IN THIS SECTION

- [Line Card Models | 107](#)
- [Line Card Components | 108](#)

The line cards in EX9200 switches combine a Packet Forwarding Engine and Ethernet interfaces on a single assembly. They are field-replaceable units (FRUs) that you can install in the line card slots on the front of the switch chassis. Line cards are hot-insertable and hot-removable: You can remove and replace them without powering off the switch or disrupting switch functions.

Line Card Models

[Table 37 on page 107](#) shows the model number, description of the line card model, and the Junos OS release in which the line card was first supported.

Table 37: EX9200-32XS Line Card

Model	Description	Junos OS Release Required
EX9200-32XS	A line card with 32 10-Gigabit Ethernet ports, each of which can house 10-gigabit small form-factor pluggable plus (SFP+) transceivers	12.3R2 or later

See [Figure 40 on page 108](#).

Figure 40: EX9200-32XS Line Card

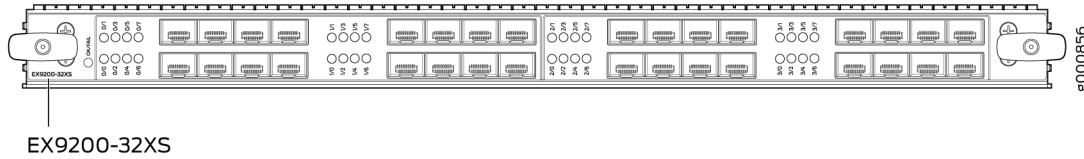

1– Ejector lever	3– LEDs for the ports
2– Line card LED	4– 10-Gigabit Ethernet ports

You can use the `show version` command to see the version of Junos OS for EX Series switches loaded on the switch.

Line Card Components

The line card has:

- 32 10-Gigabit Ethernet ports, each of which can house SFP+ transceivers
- 32 dust covers for the ports (shipped in an accessory bag)
- Line card LED—An LED labeled **OK/FAIL**, which indicates the status of the line card. See *Line Card LED in an EX9200 Switch*.
- LEDs for the ports—One LED on each port, the Link/Activity LED, which indicates the link status and activity on the port. See *Network Port LEDs on Line Cards in an EX9200 Switch*.

The ports are divided into two port groups of 16 ports each—the ports labeled **0/0** through **0/7** and **1/0** through **1/7** form one port group; the ports labeled **2/0** through **2/7** and **3/0** through **3/7** form the other port group. The ports in each group share 130 gigabits of bandwidth. Thus, you can transmit up to 130 gigabits of traffic through a port group, without packet drop.

EX9200-40T Line Card

IN THIS SECTION

Line Card Models | 109

The line cards in EX9200 switches provide packet forwarding services. They are field-replaceable units (FRUs) that you can install in the line card slots on the front of the switch chassis. Line cards are hot-insertable and hot-removable: You can remove and replace them without powering off the switch or disrupting switch functions.

Line Card Models

Table 38 on page 109 shows the model number, description of the line card model, and the Junos OS release in which the line card was first supported.

Table 38: EX9200-40T Line Card

Model	Description	Junos OS Release Required
EX9200-40T	A line card with 40 RJ-45 ports that support RJ-45 connectors	12.3R2 or later

See Figure 41 on page 109.

Figure 41: EX9200-40T Line Card

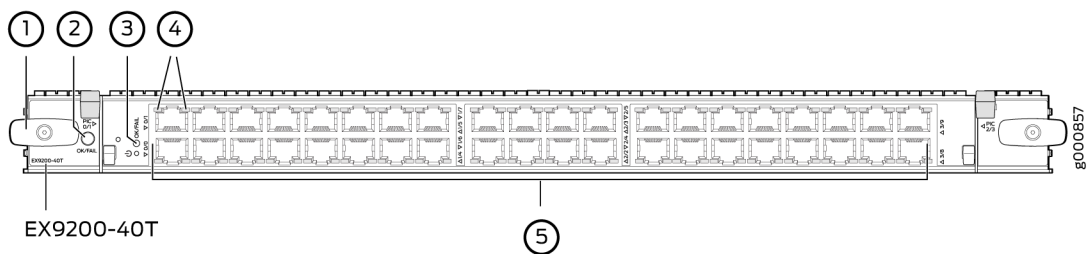

1– Ejector lever	4– LEDs for the ports
2– Line card LED	5– RJ-45 ports
3– MIC LED	

You can use the `show version` command to see the version of Junos OS for EX Series switches loaded on the switch.

Line Card Components

The EX9200-40T line card has:

- 40 RJ-45 ports that support RJ-45 connectors
- Line card LED—An LED labeled **OK/FAIL**, which indicates the status of the line card. See *Line Card LED in an EX9200 Switch*
- MIC LED—An LED labeled **OK/FAIL** on each MIC, which indicates the status of the MIC. See *Modular Interface Card LED in an EX9200 Switch*.
- LEDs for the ports—One LED on each port, the Link/Activity LED, which indicates the link status and activity on the port and another LED, the Status LED, which indicates the status of the port parameters. See *Network Port LEDs on Line Cards in an EX9200 Switch*.

EX9200-40F Line Card

IN THIS SECTION

- [Line Card Models | 110](#)
- [Line Card Components | 111](#)

The line cards in EX9200 switches combine a Packet Forwarding Engine and Ethernet interfaces on a single assembly. They are field-replaceable units (FRUs) that you can install in the line card slots on the front of the switch chassis. Line cards are hot-insertable and hot-removable: You can remove and replace them without powering off the switch or disrupting switch functions.

Line Card Models

[Table 39 on page 111](#) shows the model number, description of the line card model, and the Junos OS release in which the line card was first supported.

Table 39: EX9200-40F Line Card

Model	Description	Junos OS Release Required
EX9200-40F	A line card with 40 1-Gigabit Ethernet ports, each of which can house 1-gigabit small form-factor pluggable (SFP) transceivers	12.3R2 or later

See [Figure 42 on page 111](#).

Figure 42: EX9200-40F Line Card

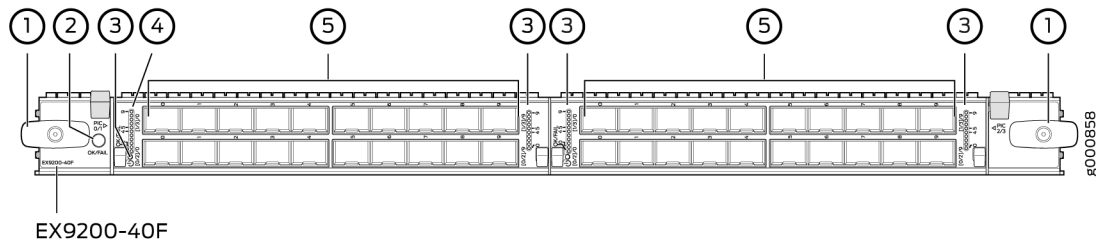

1– Ejector lever	4– LEDs for the ports
2– Line card LED	5– 1-Gigabit Ethernet ports
3– MIC LED	

You can use the `show version` command to see the version of Junos OS for EX Series switches loaded on the switch.

Line Card Components

The EX9200-40F line card has:

- 40 1-Gigabit Ethernet ports, each of which can house SFP transceivers
- 40 dust covers for the ports (shipped in an accessory bag)
- Line card LED—An LED labeled **OK/FAIL**, which indicates the status of the line card. See *Line Card LED in an EX9200 Switch*.
- MIC LED—An LED labeled **OK/FAIL** on each MIC, which indicates the status of the MIC. See *Modular Interface Card LED in an EX9200 Switch*.
- LEDs for the ports—One LED on each port, the Link/Activity LED, which indicates the link status and activity on the port. See *Network Port LEDs on Line Cards in an EX9200 Switch*.

The ports labeled **0/0** through **0/9** form pic 0 and the ports labeled **1/0** through **1/9** form pic 1. The ports labeled **2/0** through **2/9** form pic 2 and the ports labeled **3/0** through **3/9** form pic 3.

EX9200-40F-M Line Card

IN THIS SECTION

- [Line Card Models | 112](#)
- [Line Card Components | 113](#)

The line cards in EX9200 switches combine a Packet Forwarding Engine and Ethernet interfaces in a single assembly. Line cards are field-replaceable units (FRUs) that you can install in the line card slots on the front of the switch chassis. Line cards are hot-insertable and hot-removable: You can remove and replace them without powering off the switch or disrupting switch functions.

Line Card Models

[Table 40 on page 112](#) shows the model number, description of the line card model, and the Junos OS release in which the line card was first supported.

Table 40: EX9200-40F-M Line Card

Model	Description	Junos OS Release Required
EX9200-40F-M	A line card with 40 1-Gigabit Ethernet ports with Media Access Control Security (MACsec) capability, each of which can house 1-gigabit small form-factor pluggable (SFP) transceivers. The EX9200-40F-M line card supports 802.1AE IEEE MAC Security standard (also known as MACsec) with AES-128 bit encryption, providing support for link-layer data confidentiality, data integrity, and data origin authentication. You must apply a single license —EX9200-SFL—to enable MACsec.	14.2R1 or later

See [Figure 43 on page 113](#).

Figure 43: EX9200-40F-M Line Card

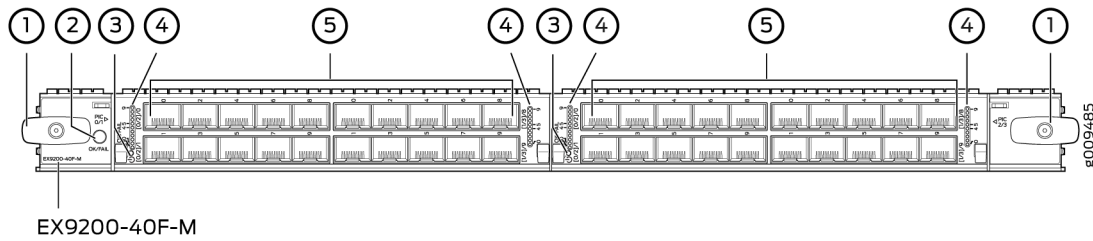

1– Ejector lever	4– LEDs for the ports
2– Line card LED	5– 1-Gigabit Ethernet ports with MACsec capability
3– MIC LED	

You can use the `show version` command to see the version of Junos OS for EX Series switches loaded on the switch.

Line Card Components

The EX9200-40F-M line card has:

- 40 1-Gigabit Ethernet MACsec-capable ports, each of which can house SFP transceivers. These ports support 1000BASE-T, 10/100/1000BASE-T, 100BASE-FX, 1000BASE-EX, 1000BASE-LH, 1000BASE-LX, and 1000BASE-SX transceivers.
- Line card LED—An LED labeled **OK/FAIL**, which indicates the status of the line card. See *Line Card LED in an EX9200 Switch*.
- MIC LED—An LED labeled **OK/FAIL** on each MIC, which indicates the status of the MIC. See *Modular Interface Card LED in an EX9200 Switch*.
- LEDs for the ports—One LED on each port, the Link/Activity LED, which indicates the link status and activity on the port. See *Network Port LEDs on Line Cards in an EX9200 Switch*.

The ports labeled **0/0** through **0/9** form pic 0. The ports labeled **1/0** through **1/9** form pic 1. The ports labeled **2/0** through **2/9** form pic 2. The ports labeled **3/0** through **3/9** form pic 3.

EX9200-40XS Line Card

IN THIS SECTION

- [Line Card Models | 114](#)
- [Line Card Components | 115](#)

The line cards in EX9200 switches combine a Packet Forwarding Engine and Ethernet interfaces in a single assembly. Line cards are field-replaceable units (FRUs) that you can install in the line card slots on the front of the switch chassis. Line cards are hot-insertable and hot-removable: You can remove and replace them without powering off the switch or disrupting switch functions.

Line Card Models

[Table 41 on page 114](#) shows the model number, description of the line card model, and the Junos OS release in which the line card was first supported.

Table 41: EX9200-40XS Line Card

Model	Description	Junos OS Release Required
EX9200-40XS	A line card with 40 10-Gigabit Ethernet ports with Media Access Control Security (MACsec) capability, each of which can house 10-gigabit small form-factor pluggable plus (SFP+) transceivers. The EX9200-40XS line card supports 802.1AE IEEE MAC Security standard (also known as MACsec) with AES-128 bit encryption and AES-256 bit encryption, providing support for link-layer data confidentiality, data integrity, and data origin authentication. You must apply a single license—EX9200-SFL—to enable MACsec.	16.1R1 or later

NOTE: For the EX9200-40XS line card to be operational, you must install the EX9200-SF2 Switch Fabric module (SF module) in the switch. See *Switch Fabric Module in an EX9200 Switch* and *Installing an SF Module in an EX9200 Switch*.

[Figure 44 on page 115](#) shows the components of an EX9200-40XS line card.

Figure 44: EX9200-40XS Line Card

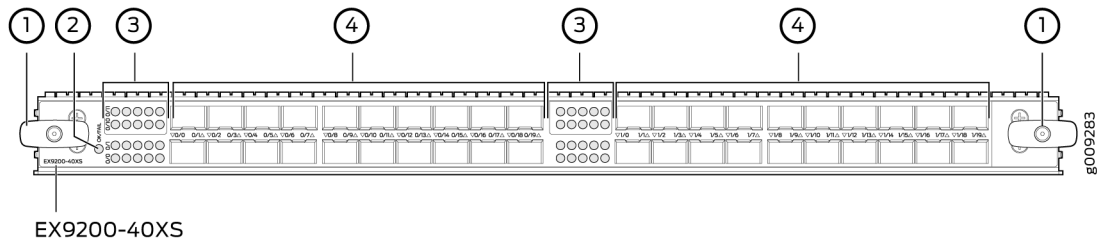

1– Ejector lever	3– LEDs for the 10-Gigabit Ethernet ports
2– Line card LEDs	4– 10-Gigabit Ethernet ports with MACsec capability

You can use the `show version` command to see the version of Junos OS for EX Series switches loaded on the switch.

Line Card Components

The EX9200-40XS line card has:

- 40 10-Gigabit Ethernet MACsec-capable ports, each of which can house SFP+ transceivers. These ports support 10GBASE-SR and 10GBASE-LR transceivers.
- 40 dust covers for the ports.
- Line card LED—An LED labeled **OK/FAIL**, which indicates the status of the line card. See *Line Card LED in an EX9200 Switch*.
- Network port LED—One LED on each network port, the Link/Activity LED, which indicates the link status and activity on the port. See *Network Port LEDs on Line Cards in an EX9200 Switch*.

The ports are divided into two port groups of 20 ports each. The 10-Gigabit Ethernet ports labeled **0/0** through **0/19** form one port group. The 10-Gigabit Ethernet ports labeled **1/0** through **1/19** form the other port group. The ports in each group share 200 gigabits of bandwidth. Thus, you can transmit up to 200 gigabits of traffic through each port group, without packet drop.

Line Card LED in an EX9200 Switch

The line cards in EX9200 switches have an LED labeled **OK/FAIL** on the faceplate that indicates the online status information of line cards.

Table 42 on page 116 describes the LED on line cards for EX9200 switches, its colors and state, and the status it indicates. For information about the LEDs on the EX9200-15C line card, see "[EX9200-15C Line Card](#)" on page 103.

Table 42: LED on Line Cards for EX9200 Switches

LED	Color	State and Description
OK/FAIL	Green	<ul style="list-style-type: none"> On steadily—The line card is functioning normally. Blinking—The line card is transitioning online or offline.
	Unlit	The line card is not online.
	Red	The line card has failed.

Network Port LEDs on Line Cards in an EX9200 Switch

Each SFP, SFP+, QSFP+, CFP, and RJ-45 port on the faceplate of line cards has an LED, the Link/Activity LED, which indicates the link status and activity on the port. Each RJ-45 port has an additional LED, the Status LED, which indicates the status of the port parameters.

Table 43 on page 116 describes the Link/Activity LED. For information about the LEDs on the EX9200-15C line card, see "[EX9200-15C Line Card](#)" on page 103.

Table 43: Network Port LEDs on Line Cards in an EX9200 Switch—Link/Activity LED

LED	Color	State and Description
Link/Activity	Green	<ul style="list-style-type: none"> On steadily—The port and the link are active, but there is no link activity. Blinking—The port and the link are active, and there is link activity. Off—The port is not active.

Table 43: Network Port LEDs on Line Cards in an EX9200 Switch—Link/Activity LED (Continued)

LED	Color	State and Description
	Yellow (applicable only for the 40-Gigabit Ethernet ports on EX9200-6QS line card)	On steadily—The link is disabled.

The Status LED in 10/100/1000BASE-T RJ-45 Ethernet network port indicates the status of one of the three port parameters—administrative status, speed, and duplex mode status.

[Table 44 on page 117](#) describes the Status LED.

Table 44: Network Port LEDs on Line Cards in an EX9200 Switch—Status LED

LED	LCD Indicator	State, Color, and Description
Status	LED: ADM	Indicates the administrative status (enabled or disabled). The status indicators are: <ul style="list-style-type: none"> • Green—Administrative status enabled. • Yellow—The port is down. • Unlit—Administrative status disabled.
	LED: SPD	Indicates the speed. The speed indicators are different in the line cards. <ul style="list-style-type: none"> • Unlit—10 Mbps • Green—Blinking—100 Mbps • Green—On steadily—1000 Mbps
	LED: DPX	Indicates the duplex mode. The status indicators are: <ul style="list-style-type: none"> • Green—Port is set to full-duplex mode. • Unlit—Port is not set to full-duplex mode.

Modular Interface Card LED in an EX9200 Switch

The Modular Interface Cards (MICs) in the following line cards for EX9200 switches have an LED labeled **OK/FAIL** on the faceplate that indicates the online status information of MICs.

- *EX9200-4QS Line Card*
- *EX9200-MPC Line Card*
- *EX9200-40F Line Card*
- *EX9200-40F-M Line Card*
- *EX9200-40T Line Card*

[Table 45 on page 118](#) describes the MIC LED on line cards for EX9200 switches, its colors and state, and the status it indicates.

Table 45: MIC LED for EX9200 Switches

LED	Color	State and Description
OK/FAIL	Green	On steadily—The MIC is functioning normally.
	Unlit	The MIC is not online.
	Red	On steadily—The MIC has failed.

Configuring Rate Selectability on an EX9200-12QS Line Card to Enable Different Port Speeds

IN THIS SECTION

- [Configuring Rate Selectability at the PIC Level | 119](#)
- [Configuring Rate Selectability at the Port Level | 121](#)

Each of the six ports of PIC 0 and PIC 1 of an EX9200-12QS line card supports port speeds of 10 Gbps and 40 Gbps. Ports 2 and 5 of both the PICs also support port speed of 100 Gbps. Because the EX9200-12QS line card is rate-selectable, you can choose to configure all ports of each PIC to operate at the same supported speed or configure the ports of a PIC to operate at different supported speeds.

You configure rate selectability at the PIC level if you want all the ports of a PIC to operate at the same speed. That is, you can choose to configure a PIC to operate at a supported speed. For example, if you configure PIC 0 at 10-Gbps or 40-Gbps speed, all the ports of PIC 0 are enabled to operate at those speeds. If you configure PIC 0 at 100-Gbps speed, port 2 and port 5 are enabled to operate at 100-Gbps speed, and the other ports of PIC 0 are disabled.

You configure rate selectability on each port of a PIC if you want to operate different ports of the line card at different supported speeds. That is, you can configure each port to operate at a specified, supported speed.

Configuring Rate Selectability at the PIC Level

To configure rate selectability at the PIC level:

1. In configuration mode, navigate to the `[edit chassis fpc fpc-slot pic pic-number]` hierarchy level.

```
[edit ]
user@host# edit chassis fpc fpc-slot pic pic-number
```

For example:

```
[edit ]
user@host# edit chassis fpc 4 pic 0
```

2. Configure the `pic-mode` statement to set the operating speed for the ports of a PIC. You can choose from the options 10G, 40G, or 100G.

```
[edit chassis fpc fpc-slot pic pic-number]
user@host# set pic-mode pic-speed
```

For example:

```
[edit chassis fpc 4 pic 0]
user@host# set pic-mode 10G
```

3. (Optional) You can choose to configure the number of ports that operate at the speed configured in Step 2.

```
[edit chassis fpc fpc-slot pic pic-number]
user@host# set number-of-ports number-of-active-physical-ports
```

For example, to specify that six ports on PIC 0 operate at the speed specified in Step 2:

```
[edit chassis fpc 4 pic 0]
user@host# set number-of-ports 6
```

4. Verify the configuration.

```
[edit chassis fpc 4 pic 0]
user@host# show
pic-mode 10G;
number-of-ports 6;
```

5. Commit your configuration changes.

6. Reset the PIC.

If the `number-of-ports` statement is *not* configured, all the ports that support the speed configured in Step 2 are enabled and the others are disabled. That is, the ports are enabled depending on whether or not they support the speed specified. Ports 0 through 5 are enabled if the speed specified is 10 Gbps or 40 Gbps; and ports 2 and 5 are enabled and the other ports of the PIC disabled if the speed specified is 100 Gbps. Table 46 lists the physical ports that are enabled when the `number-of-ports` statement is configured.

Table 46: Active Physical Ports on EX9200-12QS Line Card Based on the number-of-ports Configuration

Ports Configured (number-of-ports Statement)	Active Physical Ports for Different Configured Speeds		
	10-Gigabit	40-Gigabit	100-Gigabit
1	0	0	2
2	0, 1	0, 1	2, 5

Table 46: Active Physical Ports on EX9200-12QS Line Card Based on the number-of-ports Configuration (Continued)

Ports Configured (number-of-ports Statement)	Active Physical Ports for Different Configured Speeds		
	10-Gigabit	40-Gigabit	100-Gigabit
3	0, 1, 2	0, 1, 2	2, 5
4	0, 1, 2, 3	0, 1, 2, 3	2, 5
5	0, 1, 2, 3, 4	0, 1, 2, 3, 4	2, 5
6	0, 1, 2, 3, 4, 5	0, 1, 2, 3, 4, 5	2, 5

Configuring Rate Selectability at the Port Level

To configure rate selectability at the port level:

1. In configuration mode, navigate to the `[edit chassis fpc fpc-slot pic pic-number]` hierarchy level.

```
[edit ]
user@host# edit chassis fpc fpc-slot pic pic-number
```

For example:

```
[edit ]
user@host# edit chassis fpc 4 pic 0
```

2. To indicate the speed at which the ports operate, configure the speed statement for specific ports. The available options are 10g, 40g, and 100g.

```
[edit chassis fpc fpc-slot pic pic-number]
user@host# set port port-number speed (10g | 40g | 100g)
```

For example:

```
[edit chassis fpc 4 pic 0]
user@host# set port 0 speed 10g
user@host# set port 1 speed 10g
user@host# set port 2 speed 100g
user@host# set port 3 speed 40g
```

NOTE: All the six ports of PIC 0 and PIC 1 of an EX9200-12QS support 10-Gbps and 40-Gbps port speeds. However, only ports 2 and 5 of both the PICs support 100-Gbps speed.

3. Verify the configuration.

```
[edit chassis fpc 4 pic 0]
user@host# show
port 0 {
    speed 10g;
}
port 1 {
    speed 10g;
}
port 2 {
    speed 100g;
}
port 3 {
    speed 40g;
}
```

4. Commit your configuration changes.

5. Reset the PIC.

NOTE: Note the following when you configure rate selectability on an EX9200-12QS line card:

- When you boot the line card:

- If rate selectability is not configured, all ports of the line card operate at the default speed as four 10-Gigabit Ethernet interfaces.
- If rate selectability is configured with invalid port speeds, all ports for which invalid speeds were configured operate at the default speed.
- If valid port speeds are configured, the ports operate at the configured speeds.
- When you change an existing port-speed configuration, for the configuration to take effect, you must do either of the following:
 - Reset the PICs to which the configured ports belong, by using the `request chassis pic pic-slot pic-slot-number fpc-slot fpc-slot-number (online | offline)` command. Because resetting the line card takes several minutes and because it affects all the Packet Forwarding Engines, use this command to apply your configuration changes quickly.
 - Reset the line card

An alarm is generated indicating the change in port-speed configuration.

- When you change an existing port-speed configuration to an invalid port-speed configuration and commit the configuration, an alarm is generated indicating that the port-speed configuration is invalid. The port continues to operate at the existing port speed.
- You cannot configure rate selectability at the PIC level and the port level simultaneously. Error messages are displayed when you try to commit such configurations.
- If you configure rate selectability at the port level, logical interfaces are created only on the configured ports. No logical interfaces are created on the other ports.

3

CHAPTER

Site Planning, Preparation, and Specifications

Site Preparation Checklist for an EX9208 Switch | 125

EX9208 Site Guidelines and Requirements | 127

EX9200 Network Cable and Transceiver Planning | 144

EX9200 Management Cable Specifications and Pinouts | 150

Site Preparation Checklist for an EX9208 Switch

The checklist in [Table 47 on page 125](#) summarizes the tasks you need to perform to prepare a site for installing an EX9208 switch.

Table 47: Site Preparation Checklist

Item or Task	For More Information	Performed by	Date
Environment			
Verify that environmental factors such as temperature and humidity do not exceed switch tolerances.	"Environmental Requirements and Specifications for EX Series Switches" on page 127		
Power			
Measure distance between external power sources and switch installation site.			
Calculate the power consumption and requirements.	"AC Power Supply Specifications for EX9208 Switches" on page 56 "DC Power Supply Specifications for EX9208 Switches" on page 63 <i>Power Requirements for EX9200 Switch Components</i> <i>Calculating the Fiber-Optic Cable Power Budget for EX Series Devices</i> <i>Calculating the Fiber-Optic Cable Power Margin for EX Series Devices</i>		
Rack or Cabinet			

Table 47: Site Preparation Checklist (Continued)

Item or Task	For More Information	Performed by	Date
<p>Select the type of rack or cabinet and verify that it meets the minimum requirements for the installation of the switch.</p>	<p>"Rack Requirements" on page 137</p> <p>"Cabinet Requirements" on page 139</p>		
<p>Plan rack or cabinet location, ensuring the required space clearances.</p>	<p>"Clearance Requirements for Airflow and Hardware Maintenance for an EX9208 Switch" on page 136</p>		
<p>Secure the rack or cabinet to the floor and building structure.</p>			
Cables			
<p>Plan the cable routing and management.</p> <p>Acquire cables and connectors:</p> <ul style="list-style-type: none"> • Determine the number of cables needed based on your planned configuration. • Ensure that the distance between hardware components to be connected allows for cable lengths to be within the specified maximum limits. 			

EX9208 Site Guidelines and Requirements

IN THIS SECTION

- [Environmental Requirements and Specifications for EX Series Switches | 127](#)
- [General Site Guidelines | 134](#)
- [Site Electrical Wiring Guidelines | 135](#)
- [Clearance Requirements for Airflow and Hardware Maintenance for an EX9208 Switch | 136](#)
- [Rack Requirements | 137](#)
- [Cabinet Requirements | 139](#)
- [Power Requirements for EX9200 Switch Components | 140](#)
- [Grounding Cable and Lug Specifications for EX9200 Switches | 142](#)

Environmental Requirements and Specifications for EX Series Switches

The switch must be installed in a rack or cabinet housed in a dry, clean, well-ventilated, and temperature-controlled environment.

Ensure that these environmental guidelines are followed:

- The site must be as dust-free as possible, because dust can clog air intake vents and filters, reducing the efficiency of the switch cooling system.
- Maintain ambient airflow for normal switch operation. If the airflow is blocked or restricted, or if the intake air is too warm, the switch might overheat, leading to the switch temperature monitor shutting down the switch to protect the hardware components.

[Table 48 on page 128](#) provides the required environmental conditions for normal switch operation.

Table 48: EX Series Switch Environmental Tolerances

Switch or device	Environment Tolerance			
	Altitude	Relative Humidity	Temperature	Seismic
EX2200-C	No performance degradation up to 5,000 feet (1524 meters)	Normal operation ensured in the relative humidity range 10% through 85% (noncondensing)	Normal operation ensured in the temperature range 32° F (0° C) through 104° F (40° C) at altitudes up to 5,000 ft (1,524 m). For information about extended temperature SFP transceivers supported on EX2200 switches, see Pluggable Transceivers Supported on EX2200 Switches .	Complies with Zone 4 earthquake requirements as per GR-63, Issue 4.
EX2200 (except EX2200-C switches)	No performance degradation up to 10,000 feet (3048 meters)	Normal operation ensured in the relative humidity range 10% through 85% (noncondensing)	Normal operation ensured in the temperature range 32° F (0° C) through 113° F (45° C)	Complies with Zone 4 earthquake requirements as per GR-63, Issue 4.
EX2300-C	No performance degradation up to 5,000 feet (1524 meters)	Normal operation ensured in the relative humidity range 10% through 85% (noncondensing)	Normal operation ensured in the temperature range 32° F (0° C) through 104° F (40° C)	Complies with Zone 4 earthquake requirements as per GR-63, Issue 4.
EX2300 (except EX2300-C switches)	No performance degradation up to 13,000 feet (3962 meters) at 104° F (40° C) as per GR-63	Normal operation ensured in the relative humidity range 10% through 85% (noncondensing)	Normal operation ensured in the temperature range 32° F (0° C) through 113° F (45° C)	Complies with Zone 4 earthquake requirements as per GR-63, Issue 4.

Table 48: EX Series Switch Environmental Tolerances (Continued)

Switch or device	Environment Tolerance			
	Altitude	Relative Humidity	Temperature	Seismic
EX3200	No performance degradation up to 10,000 feet (3048 meters)	Normal operation ensured in the relative humidity range 10% through 85% (noncondensing)	Normal operation ensured in the temperature range 32° F (0° C) through 113° F (45° C)	Complies with Zone 4 earthquake requirements as per GR-63, Issue 4.
EX3300	No performance degradation up to 10,000 feet (3048 meters)	Normal operation ensured in the relative humidity range 10% through 85% (noncondensing)	Normal operation ensured in the temperature range 32° F (0° C) through 113° F (45° C)	Complies with Zone 4 earthquake requirements as per GR-63, Issue 4.
EX3400	No performance degradation up to 10,000 feet (3048 meters)	Normal operation ensured in the relative humidity range 10% through 85% (noncondensing)	Normal operation ensured in the temperature range 32° F (0° C) through 113° F (45° C)	Complies with Zone 4 earthquake requirements as per GR-63, Issue 4.
EX4100	No performance degradation up to 5,000 feet (1524 meters)	Normal operation ensured in the relative humidity range 10% through 85% (noncondensing)	Normal operation ensured in the temperature range 32° F (0° C) through 113° F (45° C)	Complies with Zone 4 earthquake requirements as per GR-63, Issue 4.
EX4200	No performance degradation up to 10,000 feet (3048 meters)	Normal operation ensured in the relative humidity range 10% through 85% (noncondensing)	Normal operation ensured in the temperature range 32° F (0° C) through 113° F (45° C)	Complies with Zone 4 earthquake requirements as per GR-63, Issue 4.

Table 48: EX Series Switch Environmental Tolerances (Continued)

Switch or device	Environment Tolerance			
	Altitude	Relative Humidity	Temperature	Seismic
EX4300	EX4300 switches except the EX4300-48MP model— No performance degradation up to 10,000 feet (3048 meters) EX4300-48MP model— No performance degradation up to 6,000 feet (1829 meters)	EX4300 switches except the EX4300-48MP model— Normal operation ensured in the relative humidity range 10% through 85% (noncondensing) EX4300-48MP model— Normal operation ensured in the relative humidity range 5% through 90% (noncondensing)	Normal operation ensured in the temperature range 32° F (0° C) through 113° F (45° C)	Complies with Zone 4 earthquake requirements as per GR-63, Issue 4.
EX4400	No performance degradation up to 6,000 feet (1829 meters)	Normal operation ensured in the relative humidity range 10% through 90% (noncondensing)	Normal operation ensured in the temperature range 32° F (0° C) through 113° F (45° C)	Complies with Zone 4 earthquake requirements as per GR-63, Issue 4.
EX4500	No performance degradation up to 10,000 feet (3048 meters)	Normal operation ensured in the relative humidity range 10% through 85% (noncondensing)	Normal operation ensured in the temperature range 32° F (0° C) through 113° F (45° C)	Complies with Zone 4 earthquake requirements as per GR-63, Issue 4.

Table 48: EX Series Switch Environmental Tolerances (Continued)

Switch or device	Environment Tolerance			
	Altitude	Relative Humidity	Temperature	Seismic
EX4550	No performance degradation up to 10,000 feet (3048 meters)	Normal operation ensured in the relative humidity range 10% through 85% (noncondensing)	<ul style="list-style-type: none"> EX4550-32F switches— Normal operation ensured in the temperature range 32° F (0° C) through 113° F (45° C) EX4550-32T switches— Normal operation is ensured in the temperature range 32° F through 104° F (40° C) 	Complies with Zone 4 earthquake requirements as per GR-63, Issue 4.
EX4600	No performance degradation to 6,562 feet (2000 meters)	<p>Normal operation ensured in the relative humidity range 5% through 90%, noncondensing</p> <ul style="list-style-type: none"> Short-term operation ensured in the relative humidity range 5% through 93%, noncondensing <p>NOTE: As defined in NEBS GR-63-CORE, Issue 4, short-term events can be up to 96 hours in duration but not more than 15 days per year.</p>	<ul style="list-style-type: none"> Normal operation ensured in the temperature range 32° F (0° C) through 113° F (45° C) Nonoperating storage temperature in shipping container: - 40° F (- 40° C) through 158° F (70° C) 	Complies with Zone 4 earthquake requirements per NEBS GR-63-CORE, Issue 4.

Table 48: EX Series Switch Environmental Tolerances (Continued)

Switch or device	Environment Tolerance			
	Altitude	Relative Humidity	Temperature	Seismic
EX4650	No performance degradation to 6,000 feet (1829 meters)	Normal operation ensured in the relative humidity range 10% through 85% (condensing)	Normal operation is ensured in the temperature range 32° F (0° C) through 104° F (40° C)	Complies with Zone 4 earthquake requirements as per GR-63, Issue 4.
EX6210	No performance degradation up to 10,000 feet (3048 meters)	Normal operation ensured in the relative humidity range 10% through 85% (noncondensing)	Normal operation is ensured in the temperature range 32° F (0° C) through 104° F (40° C)	Complies with Zone 4 earthquake requirements as per GR-63, Issue 4.
EX8208	No performance degradation up to 10,000 feet (3048 meters)	Normal operation ensured in the relative humidity range 10% through 85% (noncondensing)	Normal operation is ensured in the temperature range 32° F (0° C) through 104° F (40° C)	Complies with Zone 4 earthquake requirements as per GR-63, Issue 4.
EX8216	No performance degradation up to 10,000 feet (3048 meters)	Normal operation ensured in the relative humidity range 10% through 85% (noncondensing)	Normal operation is ensured in the temperature range 32° F (0° C) through 104° F (40° C)	Complies with Zone 4 earthquake requirements as per GR-63, Issue 4.

Table 48: EX Series Switch Environmental Tolerances (Continued)

Switch or device	Environment Tolerance			
	Altitude	Relative Humidity	Temperature	Seismic
EX9204	No performance degradation up to 10,000 feet (3048 meters)	Normal operation ensured in the relative humidity range 5% through 90% (noncondensing)	Normal operation is ensured in the temperature range 32° F (0° C) through 104° F (40° C) Nonoperating storage temperature in shipping container: - 40° F (- 40° C) to 158° F (70° C)	Complies with Zone 4 earthquake requirements as per GR-63.
EX9208	No performance degradation up to 10,000 feet (3048 meters)	Normal operation ensured in the relative humidity range 5% through 90% (noncondensing)	Normal operation is ensured in the temperature range 32° F (0° C) through 104° F (40° C) Nonoperating storage temperature in shipping container: - 40° F (- 40° C) to 158° F (70° C)	Complies with Zone 4 earthquake requirements as per GR-63.
EX9214	No performance degradation up to 10,000 feet (3048 meters)	Normal operation ensured in the relative humidity range 5% through 90% (noncondensing)	Normal operation is ensured in the temperature range 32° F (0° C) through 104° F (40° C) Nonoperating storage temperature in shipping container: - 40° F (- 40° C) through 158° F (70° C)	Complies with Zone 4 earthquake requirements as per GR-63.

Table 48: EX Series Switch Environmental Tolerances (Continued)

Switch or device	Environment Tolerance			
	Altitude	Relative Humidity	Temperature	Seismic
EX9251	No performance degradation up to 10,000 ft (3048 m)	Normal operation ensured in relative humidity range of 5% to 90%, noncondensing	Normal operation ensured in temperature range of 32° F (0° C) to 104° F (40° C) Nonoperating storage temperature in shipping container: - 40° F (- 40° C) to 158° F (70° C)	Complies with Telcordia Technologies Zone 4 earthquake requirements
XRE200	No performance degradation up to 10,000 feet (3048 meters)	Normal operation ensured in the relative humidity range 10% through 85% (noncondensing)	Normal operation ensured in the temperature range 41° F (5° C) through 104° F (40° C)	Complies with Zone 4 earthquake requirements as per GR-63, Issue 4.

NOTE: Install EX Series switches only in restricted areas, such as dedicated equipment rooms and equipment closets, in accordance with Articles 110- 16, 110- 17, and 110- 18 of the National Electrical Code, ANSI/NFPA 70.

General Site Guidelines

Efficient device operation requires proper site planning and maintenance. It also requires proper layout of the equipment, rack or cabinet, and wiring closet.

To plan and create an acceptable operating environment for your device and prevent environmentally caused equipment failures:

- Keep the area around the chassis free from dust and conductive material, such as metal flakes.
- Follow the prescribed airflow guidelines to ensure that the cooling system functions properly. Ensure that exhaust from other equipment does not blow into the intake vents of the device.

- Follow the prescribed electrostatic discharge (ESD) prevention procedures to prevent damaging the equipment. Static discharge can cause components to fail completely or intermittently over time.
- Install the device in a secure area, so that only authorized personnel can access the device.

Site Electrical Wiring Guidelines

Table 49 on page 135 describes the factors you must consider while planning the electrical wiring at your site.



WARNING: You must provide a properly grounded and shielded environment and use electrical surge-suppression devices.

Avertissement Vous devez établir un environnement protégé et convenablement mis à la terre et utiliser des dispositifs de parasurtension.

Table 49: Site Electrical Wiring Guidelines

Site Wiring Factor	Guidelines
Signaling limitations	<p>If your site experiences any of the following problems, consult experts in electrical surge suppression and shielding:</p> <ul style="list-style-type: none"> • Improperly installed wires cause radio frequency interference (RFI). • Damage from lightning strikes occurs when wires exceed recommended distances or pass between buildings. • Electromagnetic pulses (EMPs) caused by lightning damage unshielded conductors and electronic devices.
Radio frequency interference	<p>To reduce or eliminate RFI from your site wiring, do the following:</p> <ul style="list-style-type: none"> • Use a twisted-pair cable with a good distribution of grounding conductors. • If you must exceed the recommended distances, use a high-quality twisted-pair cable with one ground conductor for each data signal, when applicable.

Table 49: Site Electrical Wiring Guidelines (Continued)

Site Wiring Factor	Guidelines
Electromagnetic compatibility	<p>If your site is susceptible to problems with electromagnetic compatibility (EMC), particularly from lightning or radio transmitters, seek expert advice.</p> <p>Strong sources of electromagnetic interference (EMI) can cause:</p> <ul style="list-style-type: none"> • Destruction of the signal drivers and receivers in the device • Electrical hazards as a result of power surges conducted over the lines into the equipment.

Clearance Requirements for Airflow and Hardware Maintenance for an EX9208 Switch

When planning the site for installing an EX9208 switch, you must allow sufficient clearance around the switch.

- For the cooling system to function properly, the airflow around the chassis must be unrestricted. Allow at least 6 in. (15.2 cm) of clearance between side-cooled switches. Allow 2.8 in. (7.1 cm) between the side of the chassis and any non-heat-producing surface such as a wall. See [Figure 45 on page 136](#).

Figure 45: Airflow Through the EX9208 Switch Chassis

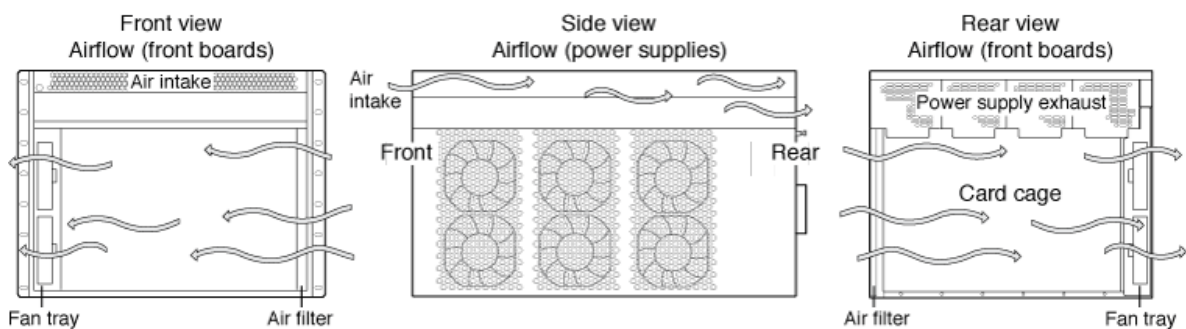

g022025

- If you are mounting the switch on a rack or cabinet along with other equipment, ensure that the exhaust from other equipment does not blow into the intake vents of the chassis.

Airflow must always be from front to back with respect to the rack. If the device has side to rear airflow, then provisions must be made to ensure that fresh air from the front of the rack is supplied to the inlets, and exhaust exits the rear of the rack. The device must not interfere with the cooling of other systems in the rack. Fillers must be used as appropriate in the rack to ensure there is no recirculation of heated exhaust air back to the front of the rack. Care must also be taken around cables to ensure that no leakage of air in situations where recirculation may result.

- For service personnel to remove and install hardware components, there must be adequate space at the front and back of the switch. At least 24 in. (61 cm) is required both in front of and behind the switch. NEBS GR-63 recommends that you allow at least 30 in. (76.2 cm) in front of the rack and 24 in. (61.0 cm) behind the rack. See [Figure 46 on page 137](#).

Figure 46: Clearance Requirements for Airflow and Hardware Maintenance for an EX9208 Switch Chassis

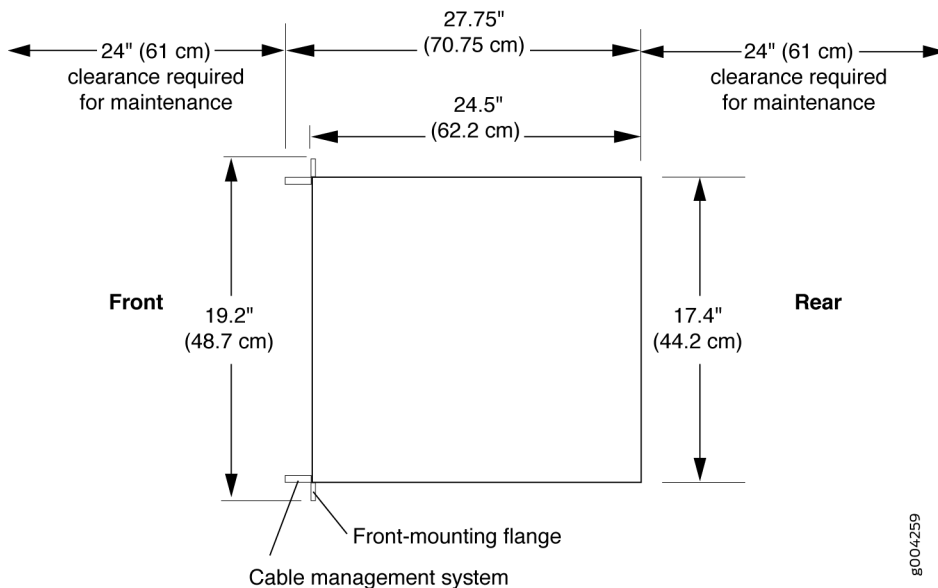

Rack Requirements

You can mount the device on two-post racks or four-post racks.

Rack requirements consist of:

- Rack type.

- Mounting bracket hole spacing.
- Rack size and strength.
- Rack connection to the building structure.

Table 50 on page 138 provides the rack requirements and specifications.

Table 50: Rack Requirements and Specifications

Rack Requirement	Guidelines
Rack type	<p>A U is the standard rack unit defined by the Electronic Components Industry Association (http://www.ecianow.org).</p> <p>You can mount the device on a rack that provides bracket holes or hole patterns spaced at 1U (1.75 in. or 4.45 cm) increments and meets the size and strength requirements to support the weight.</p>
Mounting bracket hole spacing	The holes in the mounting brackets are spaced at 1U (1.75 in. or 4.45 cm) so that the device can be mounted in any rack that provides holes spaced at that distance.
Rack size and strength	<p>Ensure that the:</p> <ul style="list-style-type: none"> • Rack complies with the size and strength standards of a 19-in. rack as defined by the Electronic Components Industry Association (http://www.ecianow.org). • Rack rails are spaced widely enough to accommodate the external dimensions of the device chassis. Ensure also that the outer edges of the front mounting brackets extend the width of the chassis to 19 in. (48.2 cm). • Rack is strong enough to support the weight of the device. • Spacing of rails and adjacent racks provides for proper clearance around the device and rack.
Rack connection to building structure	<p>Secure the rack as follows:</p> <ul style="list-style-type: none"> • Secure the rack to the building structure. • If your geographical area is earthquake-prone, secure the rack to the floor. • Secure the rack to the ceiling brackets as well as wall or floor brackets for maximum stability.

SEE ALSO

| [Rack-Mounting and Cabinet-Mounting Warnings](#)

Cabinet Requirements

You can mount the device in a cabinet that contains a 19-in. rack.

Cabinet requirements consist of:

- Cabinet size.
- Clearance requirements.
- Cabinet airflow requirements.

[Table 51 on page 139](#) provides the cabinet requirements and specifications.

Table 51: Cabinet Requirements and Specifications

Cabinet Requirement	Guidelines
Cabinet size	<ul style="list-style-type: none"> • The minimum cabinet size is 36 in. (91.4 cm) deep. Large cabinets improve airflow and reduce chances of overheating.
Cabinet clearance	<ul style="list-style-type: none"> • The outer edges of the front mounting brackets extend the width of the chassis to 19 in. (48.2 cm). • The minimum total clearance inside the cabinet is 30.7 in. (78 cm) between the inside of the front door and the inside of the rear door.

Table 51: Cabinet Requirements and Specifications (Continued)

Cabinet Requirement	Guidelines
Cabinet airflow requirements	<p>When you mount the device in a cabinet, ensure that ventilation through the cabinet is sufficient to prevent overheating, as follows:</p> <ul style="list-style-type: none"> • Ensure adequate cool air supply to dissipate the thermal output of the device or devices. • Ensure that the hot air exhaust of the chassis exits the cabinet without recirculating into the device. An open cabinet (without a top or doors) that employs hot air exhaust extraction from the top ensures the best airflow through the chassis. If the cabinet contains a top or doors, perforations in these elements assist with removing the hot air exhaust. • Install the device in the cabinet in a way that maximizes the open space on the side of the chassis that has the hot air exhaust. • Route and secure all cables to minimize the blockage of airflow to and from the chassis. • Ensure that the spacing of rails and adjacent cabinets is such that proper clearance exists around the device and cabinet. • A cabinet larger than the minimum required provides better airflow and reduces the chance of overheating.

Power Requirements for EX9200 Switch Components

[Table 52 on page 141](#) lists the power requirements for different hardware components of EX9200 switches.

Table 52: EX9200 Switch Component Power Requirements

Component	Typical Power (watt)	Reserved Power (watt)
Base system	<ul style="list-style-type: none"> EX9204 switch: 410 W EX9208 switch: 560 W EX9214 switch: 1290 W 	<ul style="list-style-type: none"> EX9204 switch: 410 W EX9208 switch: 560 W EX9214 switch: 1670 W
Redundant system	<ul style="list-style-type: none"> EX9204 switch: 690 W EX9208 switch: 800 W EX9214 switch: 1530 W 	<ul style="list-style-type: none"> EX9204 switch: 690 W EX9208 switch: 800 W EX9214 switch: 1910 W
EX9200-SF Switch Fabric module	150 W	150 W
EX9200-SF2 Switch Fabric module	155 W	155 W
EX9200-SF3 Switch Fabric module	245 W	270 W
Routing Engine module (RE module)	90 W	90 W
EX9200-2C-8XS line card	530 W	610 W
EX9200-4QS line card	408 W	520 W
EX9200-6QS line card	511 W	607 W
EX9200-MPC line card	461 W	534 W
EX9200-10XS-MIC	29.8 W	29.8 W
EX9200-20F-MIC	37 W	37 W

Table 52: EX9200 Switch Component Power Requirements (Continued)

Component	Typical Power (watt)	Reserved Power (watt)
EX9200-40T-MIC	41 W	41 W
EX9200-12QS line card	465 W	545 W
EX9200-15C line card	720 W	785 W
EX9200-32XS line card	550 W	610 W
EX9200-40T line card	206 W	239 W
EX9200-40F line card	219 W	239 W
EX9200-40F-M line card	219 W	239 W
EX9200-40XS line card	465 W	545 W

Grounding Cable and Lug Specifications for EX9200 Switches

IN THIS SECTION

- [Grounding Points Specifications for an EX9200 Switch | 143](#)
- [Grounding Cable Lug Specifications for an EX9200 Switch | 143](#)
- [Grounding Cable Specifications for an EX9200 Switch | 144](#)

To ensure proper operation and to meet safety and electromagnetic interference (EMI) requirements, you must connect an EX9200 switch to earth ground before you connect power to the switch. You must use the protective earthing terminal on the switch chassis to connect the switch to earth ground.



WARNING: The switch is installed in a restricted-access location. It has a separate protective earthing terminal on the chassis that must be permanently connected to earth ground to adequately ground the chassis and protect the operator from electrical hazards.



CAUTION: Before switch installation begins, ensure that a licensed electrician has attached an appropriate grounding lug to the grounding cable that you supply. Using a grounding cable with an incorrectly attached lug can damage the switch.

Grounding Points Specifications for an EX9200 Switch

To meet safety and electromagnetic interference (EMI) requirements and to ensure proper operation, the switch must be adequately grounded before power is connected. To ground AC-powered and DC-powered switches, you must connect a grounding cable to earth ground and then attach it to the chassis grounding points using the two screws provided.

Two threaded inserts (PEM nuts) are provided on the upper rear of the chassis for connecting the switch to earth ground. The grounding points fit UNC 1/4-20 screws (American). The grounding points are spaced at 0.625 in. (15.86 mm) centers.

NOTE: Additional grounding is provided to an AC-powered switch when you plug its power supplies into grounded AC power receptacles.

Grounding Cable Lug Specifications for an EX9200 Switch

The accessory box shipped with the switch includes one cable lug that attaches to the grounding cable (see [Figure 47 on page 143](#)) and two UNC 1/4-20 screws used to secure the grounding cable to the grounding points.

Figure 47: Grounding Lug for an EX9200 Switch

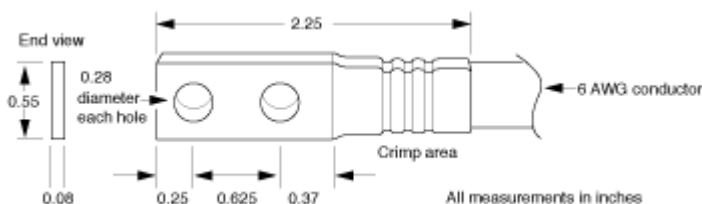



CAUTION: Before switch installation begins, a licensed electrician must attach a cable lug to the grounding and power cables that you supply. A cable with an incorrectly attached lug can damage the switch.

NOTE: The same cable lug is used for the DC power cables.

Grounding Cable Specifications for an EX9200 Switch

The grounding cable that you provide must meet the specifications in [Table 53 on page 144](#).

Table 53: Grounding Cable Specifications

Cable Type	Quantity and Specification
Grounding	<p>One 6 AWG (13.3 mm²), minimum 60 °C wire, or one that complies with the by the local code</p> <p>For DC-powered EX9214 switches, the 48 VDC facility must be equipped with a circuit breaker rated 40 A (–48 VDC), or 60 A (–48 VDC), and the grounding cable must be minimum 10 AWG, or one that complies with the by the local code.</p>

EX9200 Network Cable and Transceiver Planning

IN THIS SECTION

- [Pluggable Transceivers Supported on EX9200 Switches | 145](#)
- [Overview of EX Series Switches: Fiber-Optic Cable Signal Loss, Attenuation, and Dispersion | 146](#)
- [Calculate the Fiber-Optic Cable Power Budget for EX Series Devices | 147](#)
- [Calculating the Fiber-Optic Cable Power Margin for EX Series Devices | 148](#)

Pluggable Transceivers Supported on EX9200 Switches

The line cards in EX9200 switches support 1-gigabit Ethernet small form-factor pluggable (SFP), 1-gigabit Fast Ethernet SFP, 10-gigabit small form-factor pluggable plus (SFP+), 40-gigabit quad small form-factor pluggable plus (QSFP+), and 100-gigabit C form-factor pluggable (CFP) transceivers.

- You can find the list of transceivers supported on EX9204 switches and information about those transceivers at the [Hardware Compatibility Tool page for EX9204](#).
- You can find the list of transceivers supported on EX9208 switches and information about those transceivers at the [Hardware Compatibility Tool page for EX9208](#).
- You can find the list of transceivers supported on EX9214 switches and information about those transceivers at the [Hardware Compatibility Tool page for EX9214](#).

NOTE: We recommend that you use only optical transceivers and optical connectors purchased from Juniper Networks with your Juniper Networks device.



CAUTION: The Juniper Networks Technical Assistance Center (JTAC) provides complete support for Juniper-supplied optical modules and cables. However, JTAC does not provide support for third-party optical modules and cables that are not qualified or supplied by Juniper Networks. If you face a problem running a Juniper device that uses third-party optical modules or cables, JTAC may help you diagnose host-related issues if the observed issue is not, in the opinion of JTAC, related to the use of the third-party optical modules or cables. Your JTAC engineer will likely request that you check the third-party optical module or cable and, if required, replace it with an equivalent Juniper-qualified component.

Use of third-party optical modules with high-power consumption (for example, coherent ZR or ZR+) can potentially cause thermal damage to or reduce the lifespan of the host equipment. Any damage to the host equipment due to the use of third-party optical modules or cables is the users' responsibility. Juniper Networks will accept no liability for any damage caused due to such use.

The Gigabit Ethernet SFP, SFP+, and QSFP+ transceivers and the 100GBASE-LR4 CFP transceivers installed in EX9200 switches support digital optical monitoring (DOM): You can view the diagnostic details for these transceivers by issuing the operational mode CLI command [show interfaces diagnostics optics](#).

Overview of EX Series Switches: Fiber-Optic Cable Signal Loss, Attenuation, and Dispersion

IN THIS SECTION

- [Signal Loss in Multimode and Single-Mode Fiber-Optic Cable | 146](#)
- [Attenuation and Dispersion in Fiber-Optic Cable | 146](#)

To determine the power budget and power margin needed for fiber-optic connections, you need to understand how signal loss, attenuation, and dispersion affect transmission. EX Series switches use various types of network cables, including multimode and single-mode fiber-optic cable.

Signal Loss in Multimode and Single-Mode Fiber-Optic Cable

Multimode fiber is large enough in diameter to allow rays of light to reflect internally (bounce off the walls of the fiber). Interfaces with multimode optics typically use LEDs as light sources. However, LEDs are not coherent light sources. They spray varying wavelengths of light into the multimode fiber, which reflects the light at different angles. Light rays travel in jagged lines through a multimode fiber, causing signal dispersion. When light traveling in the fiber core radiates into the fiber, higher-order mode loss (HOL) occurs. (Cladding consists of layers of lower-refractive index material in close contact with a core material of higher refractive index.) Together, these factors reduce the transmission distance of multimode fiber compared to that of single-mode fiber.

Single-mode fiber is so small in diameter that rays of light reflect internally through one layer only. Interfaces with single-mode optics use lasers as light sources. Lasers generate a single wavelength of light, which travels in a straight line through the single-mode fiber. Compared to multimode fiber, single-mode fiber has a higher bandwidth and can carry signals for longer distances. Single-mode fiber is consequently more expensive than multimode fiber.

Exceeding the maximum transmission distances can result in significant signal loss, which causes unreliable transmission.

Attenuation and Dispersion in Fiber-Optic Cable

An optical data link functions correctly provided that modulated light reaching the receiver has enough power to be demodulated correctly. *Attenuation* is the reduction in strength of the light signal during transmission. Passive media components such as cables, cable splices, and connectors cause attenuation. Although attenuation is significantly lower for optical fiber than for other media, it still

occurs in both multimode and single-mode transmissions. An efficient optical data link must transmit enough light to overcome attenuation.

Dispersion is the spreading of the signal over time. The following two types of dispersion can affect signal transmission through an optical data link:

- Chromatic dispersion, which is the spreading of the signal over time caused by the different speeds of light rays
- Modal dispersion, which is the spreading of the signal over time caused by the different propagation modes in the fiber

For multimode transmission, modal dispersion usually limits the maximum bit rate and link length. Chromatic dispersion or attenuation is not a factor.

For single-mode transmission, modal dispersion is not a factor. However, at higher bit rates and over longer distances, chromatic dispersion limits the maximum link length.

An efficient optical data link must have enough light to exceed the minimum power that the receiver requires to operate within its specifications. In addition, the total dispersion must be within the limits specified for the type of link in Telcordia Technologies document GR-253-CORE (Section 4.3) and International Telecommunications Union (ITU) document G.957.

When chromatic dispersion is at the maximum allowed, you can consider its effect as a power penalty in the power budget. The optical power budget must allow for the sum of component attenuation, power penalties (including those from dispersion), and a safety margin for unexpected power loss.

Calculate the Fiber-Optic Cable Power Budget for EX Series Devices

To ensure that fiber-optic connections have sufficient power for correct operation, calculate the link's power budget when planning fiber-optic cable layout and distances. This planning helps you ensure that fiber-optic connections have sufficient power for correct operation. The power budget is the maximum amount of power the link can transmit. When you calculate the power budget, you use a worst-case analysis to provide a margin of error. You use a worst-case analysis even though not all the parts of an actual system operate at the worst-case levels.

To calculate the worst-case estimate for a fiber-optic cable power budget (P_B) for the link:

1. Determine values for the link's minimum transmitter power (P_T) and minimum receiver sensitivity (P_R). In the following example, we measure both (P_T) and (P_R) in decibels relative to one milliwatt (dBm).

$$P_T = -15 \text{ dBm}$$

$$P_R = -28 \text{ dBm}$$

NOTE: See the specifications for your transmitter and receiver to find the minimum transmitter power and minimum receiver sensitivity.

2. Calculate the power budget (P_B) by subtracting (P_R) from (P_T):
 $-15 \text{ dBm} - (-28 \text{ dBm}) = 13 \text{ dBm}$

Calculating the Fiber-Optic Cable Power Margin for EX Series Devices

Before calculating the power margin, calculate the power budget (see *Calculating the Fiber-Optic Cable Power Budget for EX Series Devices*).

Calculate the link's power margin when planning fiber-optic cable layout and distances to ensure that fiber-optic connections have sufficient signal power to overcome system loss and still satisfy the minimum input requirements of the receiver for the required performance level. The power margin (P_M) is the amount of power available after you subtract attenuation or link loss (LL) from the power budget (P_B).

When you calculate the power margin, you use a worst-case analysis to provide a margin of error, even though not all parts of an actual system operate at worst-case levels. A power margin (P_M) greater than zero indicates that the power budget is sufficient to operate the receiver and that it does not exceed the maximum receiver input power. This means that the link will work. A (P_M) that is zero or negative indicates insufficient power to operate the receiver. See the specification for your receiver to find the maximum receiver input power.

To calculate the worst-case estimate for the power margin (P_M) for the link:

1. Determine the maximum value for link loss (LL) by adding estimated values for applicable link-loss factors—for example, use the sample values for various factors as provided in [Table 54 on page 148](#) (here, the link is 2 km long and multimode, and the (P_B) is 13 dBm):

Table 54: Estimated Values for Factors Causing Link Loss

Link-Loss Factor	Estimated Link-Loss Value	Sample (LL) Calculation Values
Higher-order mode losses (HOL)	<ul style="list-style-type: none"> • Multimode—0.5 dBm • Single mode—None 	<ul style="list-style-type: none"> • 0.5 dBm • 0 dBm

Table 54: Estimated Values for Factors Causing Link Loss (*Continued*)

Link-Loss Factor	Estimated Link-Loss Value	Sample (LL) Calculation Values
Modal and chromatic dispersion	<ul style="list-style-type: none"> Multimode—None, if product of bandwidth and distance is less than 500 MHz/km Single mode—None 	<ul style="list-style-type: none"> 0 dBm 0 dBm
Connector	0.5 dBm	This example assumes 5 connectors. Loss for 5 connectors: $(5) * (0.5 \text{ dBm}) = 2.5 \text{ dBm}$
Splice	0.5 dBm	This example assumes 2 splices. Loss for two splices: $(2) * (0.5 \text{ dBm}) = 1 \text{ dBm}$
Fiber attenuation	<ul style="list-style-type: none"> Multimode—1 dBm/km Single mode—0.5 dBm/km 	This example assumes the link is 2 km long. Fiber attenuation for 2 km: <ul style="list-style-type: none"> $(2 \text{ km}) * (1.0 \text{ dBm/km}) = 2 \text{ dBm}$ $(2 \text{ km}) * (0.5 \text{ dBm/km}) = 1 \text{ dBm}$
Clock Recovery Module (CRM)	1 dBm	1 dBm

NOTE: For information about the actual amount of signal loss caused by equipment and other factors, see your vendor documentation for that equipment.

2. Calculate the (P_M) by subtracting (LL) from (P_B):

$$P_B - LL = P_M$$

$$(13 \text{ dBm}) - (0.5 \text{ dBm [HOL]}) - ((5) * (0.5 \text{ dBm})) - ((2) * (0.5 \text{ dBm})) - ((2 \text{ km}) * (1.0 \text{ dBm/km})) - (1 \text{ dB [CRM]}) = P_M$$

$$13 \text{ dBm} - 0.5 \text{ dBm} - 2.5 \text{ dBm} - 1 \text{ dBm} - 2 \text{ dBm} - 1 \text{ dBm} = P_M$$

$$P_M = 6 \text{ dBm}$$

The calculated power margin is greater than zero, indicating that the link has sufficient power for transmission. Also, the power margin value does not exceed the maximum receiver input power. Refer to the specification for your receiver to find the maximum receiver input power.

EX9200 Management Cable Specifications and Pinouts

IN THIS SECTION

- [Management Cable Specifications | 150](#)
- [Console Port Connector Pinout Information | 151](#)
- [USB Port Specifications for an EX Series Switch | 152](#)
- [RJ-45 Management Port Connector Pinout Information | 153](#)
- [RJ-45 to DB-9 Serial Port Adapter Pinout Information | 154](#)

Management Cable Specifications

[Table 55 on page 150](#) lists the specifications for the cables that connect the console and management ports to management devices.

Table 55: Specifications of Cables to Connect to Management Devices

Ports	Cable Specifications	Receptacle	Additional Information
RJ-45 Console port	Rollover cable	RJ-45	<i>Connect a Device to a Management Console Using an RJ-45 Connector</i>
Management Ethernet port	Ethernet cable with an RJ-45 connector	RJ-45	<i>Connect a Device to a Network for Out-of-Band Management</i>

Table 55: Specifications of Cables to Connect to Management Devices (Continued)

Ports	Cable Specifications	Receptacle	Additional Information
Mini-USB Type-B Console port	Mini-USB cable with standard-A and Mini-USB Type-B (5-pin) connector	Mini-USB	

Console Port Connector Pinout Information

The console port on a Juniper Networks device is an RS-232 serial interface that uses an RJ-45 connector to connect to a console management device. The default baud rate for the console port is 9600 baud.

Table 56 on page 152 provides the pinout information for the RJ-45 console connector.

NOTE: We no longer include the RJ-45 console cable with the DB-9 adapter as part of the device package. If the console cable and adapter are not included in your device package, or if you need a different type of adapter, you can order the following separately:

- RJ-45 to DB-9 adapter (JNP-CBL-RJ45-DB9)
- RJ-45 to USB-A adapter (JNP-CBL-RJ45-USBA)
- RJ-45 to USB-C adapter (JNP-CBL-RJ45-USBC)

If you want to use RJ-45 to USB-A or RJ-45 to USB-C adapter you must have X64 (64-Bit) Virtual COM port (VCP) driver installed on your PC. See, <https://ftdichip.com/drivers/vcp-drivers/> to download the driver.

NOTE: If your laptop or desktop PC does not have a DB-9 plug connector pin and you want to connect your laptop or desktop PC directly to a device, use a combination of the RJ-45-to-DB-9 socket adapter and a USB-to-DB-9 plug adapter. You must provide the USB-to-DB-9 plug adapter.

Table 56: Console Port Connector Pinout Information

Pin	Signal	Description
1	NC	No connect
2	NC	No connect
3	TxD Output	Transmit data
4	GND	Signal ground
5	GND	Signal ground
6	RxD Input	Receive data
7	DCD Input	Data carrier detect
8	NC	No connect

USB Port Specifications for an EX Series Switch

Juniper Networks tested and officially supports the following USB flash drives for the USB port on all EX Series switches:

- RE-USB-1G-S
- RE-USB-2G-S
- RE-USB-4G-S



CAUTION: Any USB memory product not listed as supported for EX Series switches has not been tested by Juniper Networks. The use of any unsupported USB memory product could expose your EX Series switch to unpredictable behavior. Juniper Networks Technical Assistance Center (JTAC) can provide only limited support for

issues related to unsupported hardware. We strongly recommend that you use only supported USB flash drives.

All USB flash drives used on EX Series switches must have the following features:

- USB 2.0 or later.
- Formatted with a FAT or MS-DOS file system.
- If the switch is running Junos OS Release 9.5 or earlier, the formatting method must use a primary boot record. Microsoft Windows formatting, by default, does not use a primary boot record. See the documentation for your USB flash drive for information about how your USB flash drive is formatted.

RJ-45 Management Port Connector Pinout Information

[Table 57 on page 153](#) provides the pinout information for the RJ-45 connector for the management port on Juniper Networks devices.

Table 57: RJ-45 Management Port Connector Pinout Information

Pin	Signal	Description
1	TRP1+	Transmit/receive data pair 1
2	TRP1-	Transmit/receive data pair 1
3	TRP2+	Transmit/receive data pair 2
4	TRP3+	Transmit/receive data pair 3
5	TRP3-	Transmit/receive data pair 3
6	TRP2-	Transmit/receive data pair 2
7	TRP4+	Transmit/receive data pair 4

Table 57: RJ-45 Management Port Connector Pinout Information (Continued)

Pin	Signal	Description
8	TRP4-	Transmit/receive data pair 4

RJ-45 to DB-9 Serial Port Adapter Pinout Information

The console port on a Juniper Networks device is an RS-232 serial interface that uses an RJ-45 connector to connect to a management device such as a laptop or a desktop PC. If your laptop or desktop PC does not have a DB-9 plug connector pin and you want to connect your laptop or desktop PC to the device, use a combination of the RJ-45 to DB-9 socket adapter along with a USB to DB-9 plug adapter.

[Table 58 on page 154](#) provides the pinout information for the RJ-45 to DB-9 serial port adapter.

Table 58: RJ-45 to DB-9 Serial Port Adapter Pinout Information

RJ-45 pin	Signal	DB-9 pin	Signal
1	NC	8	CTS
2	NC	6	DSR
3	TxD	2	RxD
4	GND	5	GND
6	RxD	3	TxD
7	DCD	4	DTR
8	NC	7	RTS

4

CHAPTER

Initial Installation and Configuration

Unpacking and Mounting the EX9208 Switch | 156

Connecting the EX9208 to Power | 173

Connecting the EX9200 to External Devices | 194

Connecting the EX9200 to the Network | 198

Configuring Junos OS on the EX9200 | 203

Unpacking and Mounting the EX9208 Switch

IN THIS SECTION

- [Unpacking the EX9200 Switch | 156](#)
- [Unpacking a Line Card Used in an EX9200 Switch | 158](#)
- [Parts Inventory \(Packing List\) for an EX9208 Switch | 159](#)
- [Register Products—Mandatory to Validate SLAs | 162](#)
- [Installing and Connecting an EX9208 Switch | 162](#)
- [Installing a Mounting Shelf in a Rack or Cabinet for an EX9208 Switch | 163](#)
- [Moving the Mounting Brackets for Center-Mounting an EX9200 Switch | 165](#)
- [Mounting an EX9200 Switch on a Rack or Cabinet Using a Mechanical Lift | 167](#)
- [Mounting an EX9208 Switch on a Rack or Cabinet Without Using a Mechanical Lift | 170](#)

Unpacking the EX9200 Switch

The switch is shipped in a wooden crate. A wooden pallet forms the base of the crate. The switch chassis is bolted to this pallet. Quick start installation instructions and a cardboard accessory box are also included in the shipping crate.

NOTE: The switch is maximally protected inside the shipping box. Do not unpack it until you are ready to begin installation.

Ensure that you have the following parts and tools available:

- Phillips (+) screwdrivers, number 1 and 2
- 1/2-in. or 13-mm open-end or socket wrench to remove bracket bolts from the shipping pallet
- Cover panels to cover any slots not occupied by a component

To unpack the switch:

1. Move the shipping crate to a staging area as close to the installation site as possible, where you have enough room to remove the components from the chassis. While the chassis is bolted to the pallet, you can use a forklift or pallet jack to move it.
2. Position the shipping crate with the arrows pointing up.
3. Open all the latches on the shipping crate.
4. Remove the front door of the shipping crate cover and set it aside.
5. Slide the remainder of the shipping crate cover off the pallet.
6. Remove the foam covering the top of the switch.
7. Remove the accessory box and the Quick Start installation instructions.
8. Verify the parts received against the lists.
9. Remove the vapor corrosion inhibitor (VCI) packs attached to the pallet, being careful not to break the VCI packs open.
10. To remove the brackets holding the chassis on the pallet, use a 1/2-in. socket wrench and a number 2 Phillips screwdriver to remove the bolts and screws from the brackets.
11. Store the brackets and bolts inside the accessory box.
12. Save the shipping crate cover, pallet, and packing materials in case you need to move or ship the switch at a later time.

Figure 48 on page 157 shows an EX9208 switch in the shipping crate. The contents are the same for all EX9200 switches.

Figure 48: Contents of the Shipping Crate for EX9200 Switches

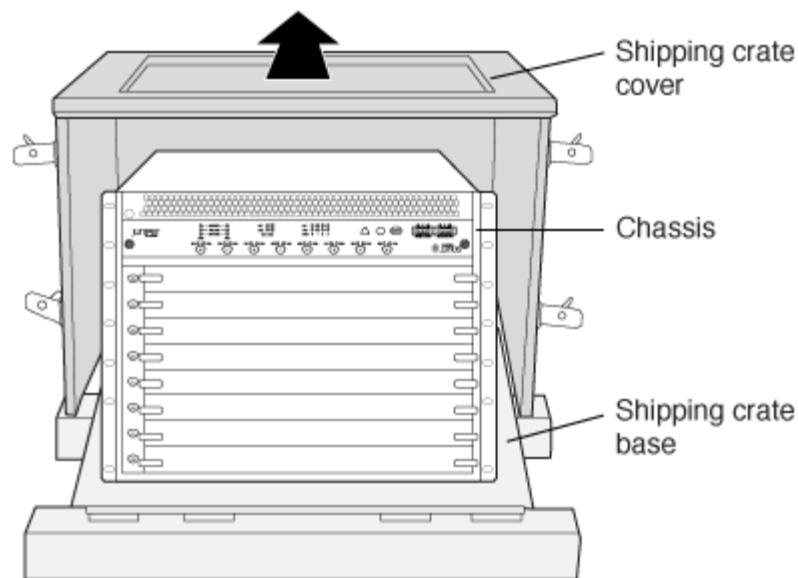

9022007

Unpacking a Line Card Used in an EX9200 Switch

Before you unpack a line card:

- Ensure that you have taken the necessary precautions to prevent electrostatic discharge (ESD) damage (see *Prevention of Electrostatic Discharge Damage*).
- Ensure that you know how to handle and store the line card (see *Handling and Storing Line Cards*).

The line cards for EX9200 switches are rigid sheet-metal structures that house the line card components including network ports. The line cards are shipped in a cardboard carton, secured with foam packing material.



CAUTION: The line cards are maximally protected inside the shipping carton. Do not unpack the line cards until you are ready to install them in the switch chassis.

To unpack a line card (see [Figure 49 on page 158](#)):

1. Move the shipping carton to a staging area as close to the installation site as possible.
2. Position the carton so that the arrows are pointing up.
3. Open the top flaps on the shipping carton.
4. Pull out the packing material, which holds the line card in place.
5. Remove the line card from the antistatic bag.
6. Save the shipping carton and packing materials in case you need to move or ship the line card later.

Figure 49: Unpacking a Line Card Used in an EX9200 Switch

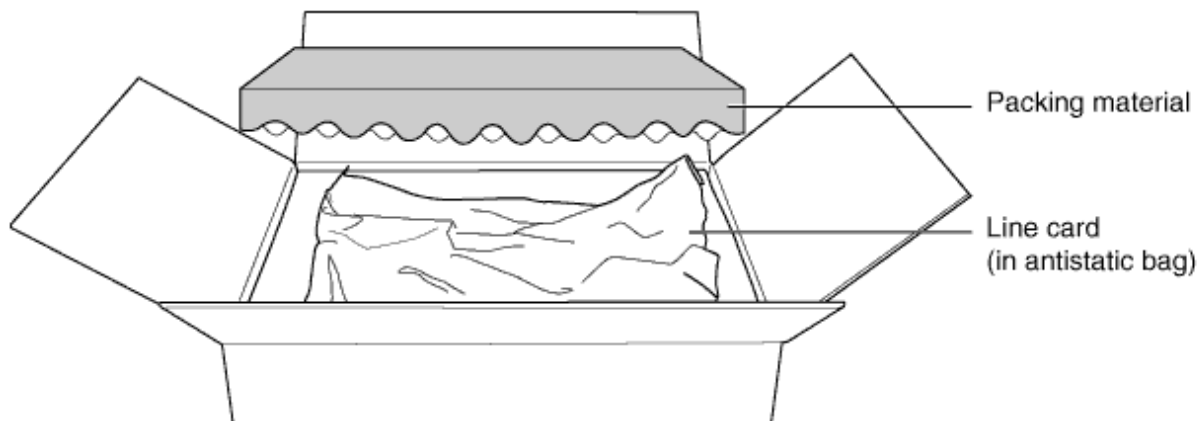

9020550

Parts Inventory (Packing List) for an EX9208 Switch

The switch shipment includes a packing list. Check the parts you receive in the switch shipping crate against the items on the packing list. The packing list specifies the part number and provides description of each part in your order. The parts shipped depend on the configuration you order. See "[EX9208 Switch Configurations](#)" on page 21 for more information.

If any part on the packing list is missing, contact your customer service representative or contact Juniper customer care from within the U.S. or Canada by telephone at 1-888-314-5822. For international-dial or direct-dial options in countries without toll-free numbers, see <https://www.juniper.net/support/requesting-support.html>.

NOTE: All line cards ordered are shipped separately. Line cards are not listed on the switch's packing list.

NOTE: The base configuration is available only with AC power supplies. The redundant configuration ships with either AC or DC power supplies.

[Table 59 on page 159](#) lists the parts and their quantities in the packing list for a base configuration and a redundant configuration switch.

Table 59: Parts List for Different EX9208 Switch Configurations

Component	Base Configuration Quantity	Redundant Configuration Quantity
Chassis, including the midplane and front-mounting brackets	1	1
Routing Engine module (RE module)	1	2
Switch Fabric module (SF module)	1	2
Power supplies	One of the following: <ul style="list-style-type: none"> • 3 low-line (100–120 VAC) AC • 2 high-line (200–240 VAC) AC 	4 AC (low-line or high-line) or 4 DC

Table 59: Parts List for Different EX9208 Switch Configurations (Continued)

Component	Base Configuration Quantity	Redundant Configuration Quantity
Fan tray	1	1
Air filter	1	1
Cover panels for slots without installed components	<ul style="list-style-type: none"> Line card cover panels: 6 SF module cover panel: 1 Power supply cover panels: 1 or 2 	<ul style="list-style-type: none"> Line card cover panels: 6

Table 60 on page 160 lists the parts contained in the accessory box. The same accessories ship with both configurations of the switch.

Table 60: Accessory Box Parts List

Part	Quantity
Screws to mount chassis and small shelf	22
DC power terminal Lugs, 6 WG	8
Cable management brackets	2
Terminal block plug, 3-pole, 5.08 mm spacing, 12A, to connect the alarms	2
Label, accessories contents, EX9208	1
Read me first document	1
Affidavit for T1 connection	1

Table 60: Accessory Box Parts List (Continued)

Part	Quantity
Juniper Networks Product Warranty	1
End User License Agreement	1
Document sleeve	1
3 in. x 5 in. pink bag	2
Documentation Roadmap	1
9 in. x 12 in. pink bag, ESD	2
Accessory Box, 19 in. x 12 in. x 3 in.	1
ESD wrist strap with cable	1

NOTE: We no longer include the RJ-45 console cable with the DB-9 adapter as part of the device package. If the console cable and adapter are not included in your device package, or if you need a different type of adapter, you can order the following separately:

- RJ-45 to DB-9 adapter (JNP-CBL-RJ45-DB9)
- RJ-45 to USB-A adapter (JNP-CBL-RJ45-USBA)
- RJ-45 to USB-C adapter (JNP-CBL-RJ45-USBC)

If you want to use RJ-45 to USB-A or RJ-45 to USB-C adapter you must have X64 (64-Bit) Virtual COM port (VCP) driver installed on your PC. See, <https://ftdichip.com/drivers/vcp-drivers/> to download the driver.

Register Products—Mandatory to Validate SLAs

Register all new Juniper Networks hardware products and changes to an existing installed product using the Juniper Networks website to activate your hardware replacement service-level agreements (SLAs).



CAUTION: Register product serial numbers on the Juniper Networks website. Update the installation base data if any addition or change to the installation base occurs or if the installation base is moved. Juniper Networks is not responsible for not meeting the hardware replacement service-level agreement for products that do not have registered serial numbers or accurate installation base data.

Register your product(s) at <https://tools.juniper.net/svcreg/SRegSerialNum.jsp>.

Update your installation base at <https://www.juniper.net/customers/csc/management/updateinstallbase.jsp>.

Installing and Connecting an EX9208 Switch

The EX9208 switch chassis is a rigid sheet-metal structure that houses the other hardware components such as Switch Fabric modules (SF modules), Routing Engine module (RE module), line cards, power supplies, fan tray, and air filter. The switch is shipped in a wooden crate. A wooden pallet forms the base of the crate.

To install and connect an EX9208 switch:

1. Follow instructions in *Unpacking the EX9200 Switch*.
2. Mount the switch by following instructions appropriate for your site:
 - *Mounting an EX9200 Switch on a Rack or Cabinet Using a Mechanical Lift*
 - ["Mounting an EX9208 Switch on a Rack or Cabinet Without Using a Mechanical Lift" on page 170](#)
3. Follow instructions in *Connect Earth Ground to an EX Series Switch*.
4. Follow instructions for connecting power as appropriate for your site:
 - ["Connecting AC Power to an EX9208 Switch" on page 184](#)
 - ["Connecting DC Power to an EX9208 Switch" on page 187](#)
5. Perform initial configuration of the switch by following instructions in *Connecting and Configuring an EX9200 Switch (CLI Procedure)*
6. Set the switch's management options by following the appropriate instructions:
 - *Connecting an EX9200 Switch to a Network for Out-of-Band Management*
 - *Connecting an EX9200 Switch to a Management Console or an Auxiliary Device*

Installing a Mounting Shelf in a Rack or Cabinet for an EX9208 Switch

The switch can be installed in a four-post rack or cabinet or in an open-frame rack. Install the mounting hardware on the rack before installing the switch.

We recommend that you install the mounting shelf, which is included in the shipping container, before installing the switch because the weight of a fully loaded chassis can be up to 163.6 lb (74.2 kg).

[Table 61 on page 163](#) specifies the holes in which you insert cage nuts and screws to install the mounting hardware required (an **X** indicates a mounting hole location). The hole distances are relative to one of the standard U divisions on the rack. The bottom of all mounting shelves is at 0.02 in. above a U division.

Table 61: Four-Post Rack or Cabinet Mounting Hole Locations

Hole	Distance Above U Division		Mounting Shelf
4	2.00 in. (5.1 cm)	1.14 U	X
3	1.51 in. (3.8 cm)	0.86 U	X
2	0.88 in. (2.2 cm)	0.50 U	X
1	0.25 in. (0.6 cm)	0.14 U	X

To install the mounting shelf on the front rails of a four-post rack or cabinet, or on the rails of an open-frame rack:

1. If needed, install cage nuts in the holes specified in [Table 61 on page 163](#).
2. On the back of each rack rail, partially insert a mounting screw into the lowest hole specified in [Table 61 on page 163](#).
3. Install the mounting shelf on the back of the rack rails. Rest the bottom slot of each flange on a mounting screw.
4. Partially insert the remaining screws into the open holes in each flange of the mounting shelf (see [Figure 50 on page 164](#) and [Figure 51 on page 165](#)).
5. Tighten all the screws completely.

Figure 50: Installing the Mounting Shelf for a Four-Post Rack or Cabinet

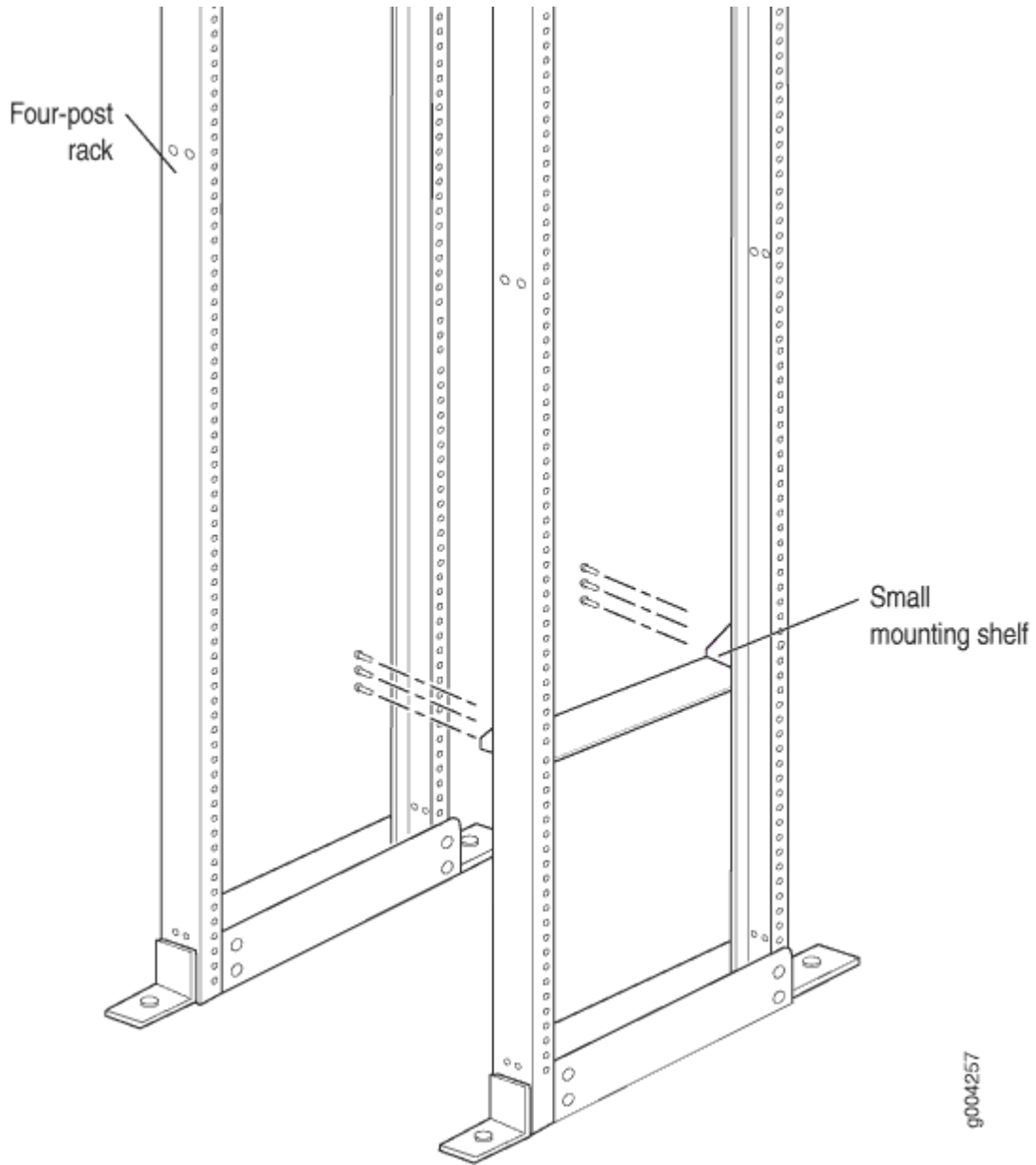
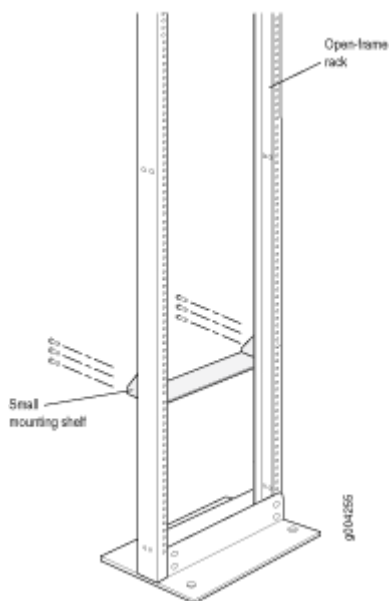

Figure 51: Installing the Mounting Shelf for an Open-Frame Rack



Moving the Mounting Brackets for Center-Mounting an EX9200 Switch

Two removable mounting brackets are attached to the mounting holes closest to the front of the chassis. You can move the pair of brackets to another position on the side of the chassis for center-mounting the switch.

To move the mounting brackets from the front of the chassis toward the center of the chassis (see [Figure 52 on page 166](#), [Figure 53 on page 166](#), or [Figure 54 on page 167](#)):

1. Remove the three screws at the top and center of the bracket.
2. Pull the top of the bracket slightly away from the chassis. The bottom of the bracket contains a tab that inserts into a slot in the chassis.
3. Pull the bracket away from the chassis so that the tab is removed from the chassis slot.
4. Insert the bracket tab into the slot in the bottom center of the chassis.
5. Align the bracket with the two mounting holes located toward the top center of the chassis.

There is no mounting hole in the center of the chassis that corresponds to the hole in the center of the bracket.

6. Insert the two screws at the top of the bracket and tighten each partially.

Two screws are needed for mounting the bracket on the center of the chassis. You do not need the third screw.

7. Tighten the two screws completely.

8. Repeat the procedure for the other bracket.

Figure 52: Moving the Mounting Brackets to the Center of the Chassis in an EX9204 Switch

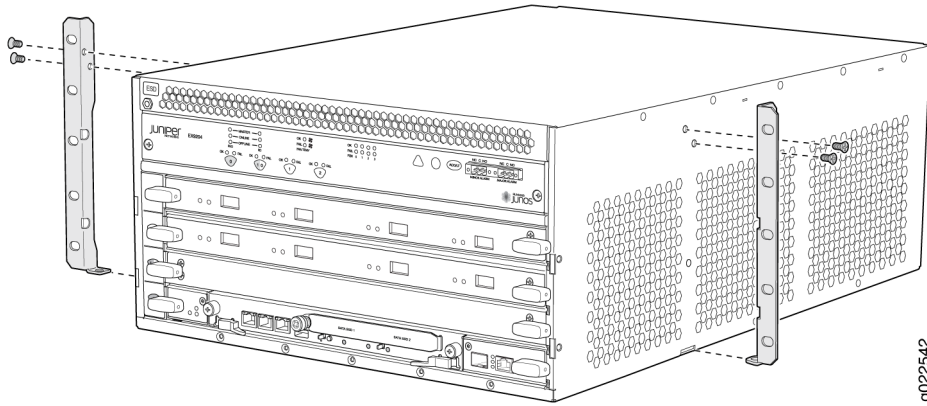

Figure 53: Moving the Mounting Brackets to the Center of the Chassis in an EX9208 Switch

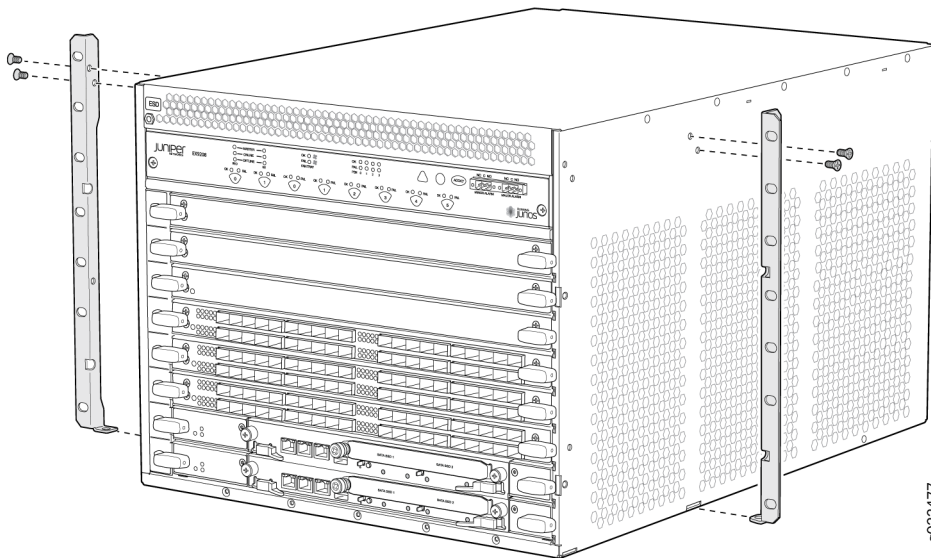
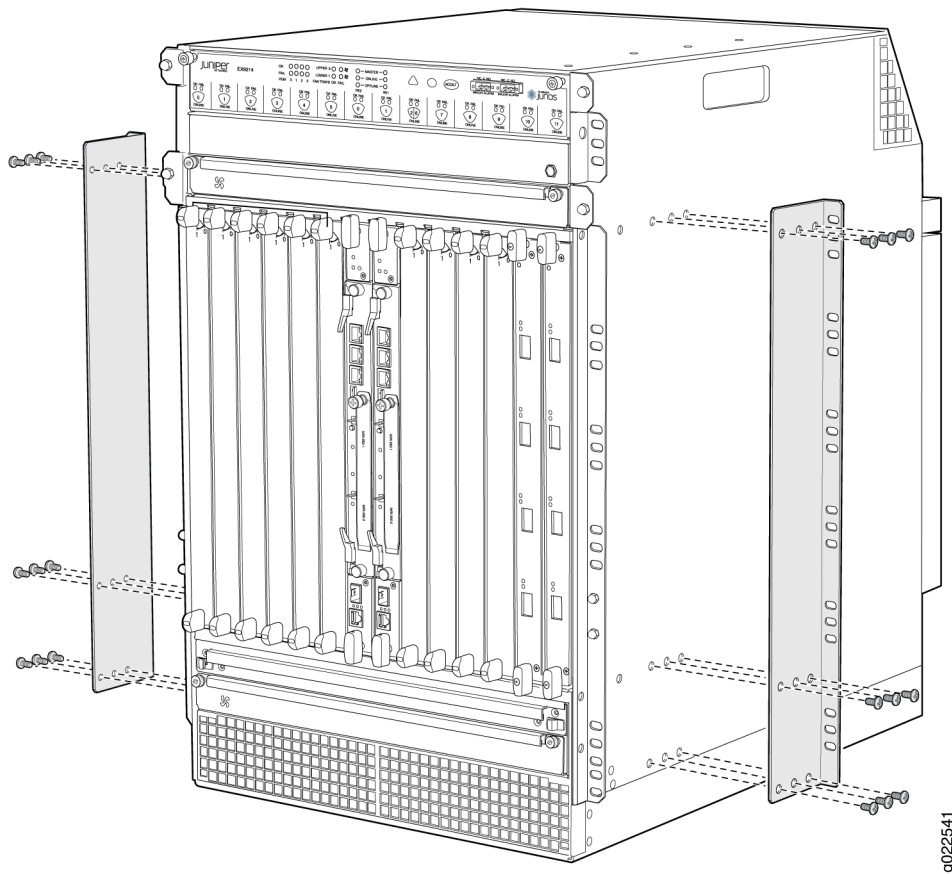

Figure 54: Moving the Mounting Brackets to the Center of the Chassis in an EX9214 Switch



Mounting an EX9200 Switch on a Rack or Cabinet Using a Mechanical Lift

Before you install the switch:

- Prepare the site for installation as described in *Site Preparation Checklist for an EX9204 Switch*, "[Site Preparation Checklist for an EX9208 Switch](#)" on page 125, or *Site Preparation Checklist for an EX9214 Switch*.
- Ensure the site has adequate clearance for both airflow and hardware maintenance as described in *Clearance Requirements for Airflow and Hardware Maintenance for an EX9204 Switch*, "[Clearance Requirements for Airflow and Hardware Maintenance for an EX9208 Switch](#)" on page 136, or *Clearance Requirements for Airflow and Hardware Maintenance for an EX9214 Switch*.

- Ensure you understand how to prevent electrostatic discharge (ESD) damage. See *Prevention of Electrostatic Discharge Damage*.
- Unpack the switch as described in *Unpacking the EX9200 Switch*.
- In a four-post rack or open-frame rack, install the mounting shelf. See *Installing a Mounting Shelf in a Rack or Cabinet for an EX9204 Switch*, "[Installing a Mounting Shelf in a Rack or Cabinet for an EX9208 Switch](#)" on page 163, or *Installing a Mounting Shelf in a Rack or Cabinet for an EX9214 Switch*.
- Review chassis lifting guidelines described in [Chassis Lifting Guidelines for EX9200 Switches](#).

Ensure that you have the following parts and tools available to install the switch:

- A mechanical lift
- 7/16-in. (11-mm) nut driver
- Phillips (+) screwdrivers, number 1 and 2
- ESD grounding wrist strap

Because of the size and weight of the switch, we strongly recommend using a mechanical lift to install the switch.



CAUTION: Do not install line cards in the chassis until after you mount the chassis securely on a rack or cabinet.



CAUTION: Before front-mounting the switch on a rack or cabinet, have a qualified technician verify that the rack or cabinet is strong enough to support the weight of the switch and is adequately supported at the installation site.



CAUTION: If you are installing more than one switch in a rack or cabinet, install the first switch at the bottom of the rack.

To install the switch using a mechanical lift:

1. Attach the ESD grounding strap to your bare wrist and connect the strap to the ESD point on the chassis.
2. Ensure that the rack or cabinet is placed in its permanent location and is secured to the building. Ensure that the installation site allows adequate clearance for both airflow and maintenance.
3. Load the switch onto the lift, making sure it rests securely on the lift platform.

4. Using the lift, position the switch in front of the rack or cabinet, centering it in front of the mounting shelf installed in the rack.
5. Lift the chassis approximately 0.75 in. (1.9 cm) above the surface of the mounting shelf and position it as close as possible to the shelf.
6. Carefully slide the switch onto the mounting shelf so that the bottom of the chassis and the mounting shelf overlap by approximately two inches.
Slide the switch onto the mounting shelf until the mounting brackets contact the rack rails. The shelf ensures that the holes in the mounting brackets of the chassis align with the holes in the rack rails.
7. Move the lift away from the rack.
8. Install a mounting screw into each of the open front-mounting holes aligned with the rack, starting from the bottom.
9. Visually inspect the alignment of the switch. If the switch is installed properly in the rack, all the mounting screws on one side of the rack are aligned with the mounting screws on the opposite side and the switch is level.

[Figure 55 on page 170](#) shows installing an EX9208 switch in an open-frame rack. The procedure is the same for all EX9200 switches.

Figure 55: Installing the Switch in an Open-Frame Rack

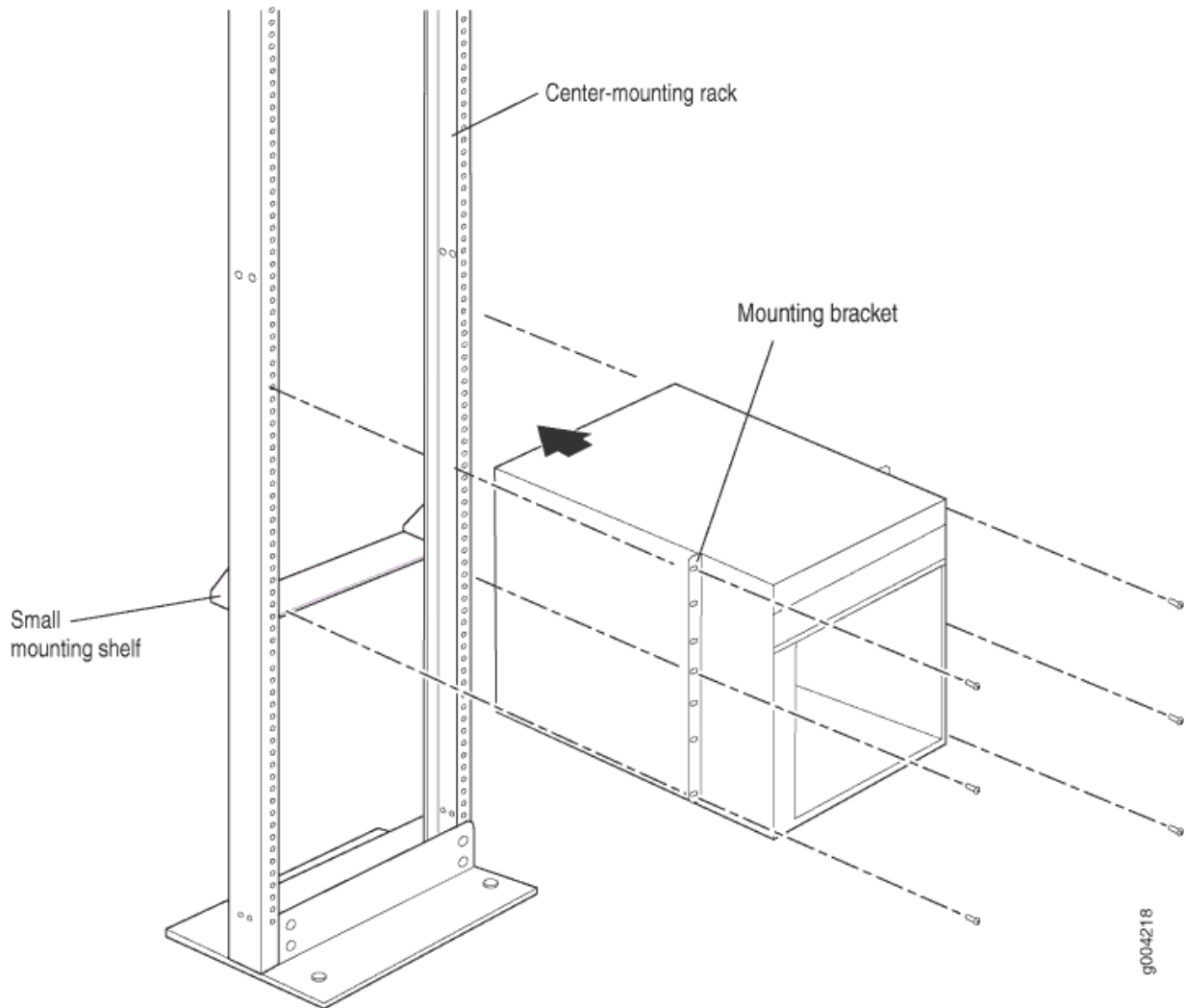

SEE ALSO

Powering On an AC-Powered EX9200 Switch

Powering On a DC-Powered EX9200 Switch

Mounting an EX9208 Switch on a Rack or Cabinet Without Using a Mechanical Lift

To install the switch in the rack (see [Figure 56 on page 172](#)):



CAUTION: If you are installing more than one switch in a rack, install the lowest one first. Installing a switch in an upper position in a rack or cabinet requires a lift.



CAUTION: Before front mounting the switch in a rack, have a qualified technician verify that the rack is strong enough to support the weight of the switch and is adequately supported at the installation site.



CAUTION: Lifting the chassis and mounting it in a rack requires two people. The empty chassis weighs approximately 65.5 lb (29.7 kg).

1. Prepare the site for installation as described in ["Site Preparation Checklist for an EX9208 Switch" on page 125](#).
2. Ensure the site has adequate clearance for both airflow and hardware maintenance as described in ["Clearance Requirements for Airflow and Hardware Maintenance for an EX9208 Switch" on page 136](#).
3. Unpack the switch as described in *Unpacking the EX9200 Switch*.
4. Remove all components except the midplane from the chassis. See:
 - *Removing an SF Module from an EX9200 Switch*
 - ["Removing an AC Power Supply from an EX9208 Switch" on page 221](#)
 - ["Removing a DC Power Supply from an EX9208 Switch" on page 224](#)
 - *Removing a Fan Tray from an EX9200 Switch*
5. Ensure that the rack is in its permanent location and is secured to the building. Ensure that the installation site allows adequate clearance for both airflow and maintenance.
6. Position the switch in front of the rack or cabinet, centering it in front of the mounting shelf. Use a pallet jack if one is available.
7. With one person on each side, hold onto the bottom of the chassis and carefully lift it onto the mounting shelf.



WARNING: To prevent injury, keep your back straight and lift with your legs, not your back. Avoid twisting your body as you lift. Balance the load evenly, and be sure that your footing is solid.

8. Slide the switch onto the mounting shelf until the mounting brackets contact the rack rails. The shelf ensures that the holes in the mounting brackets of the chassis align with the holes in the rack rails.
9. Install a mounting screw into each of the open mounting holes aligned with the rack, starting from the bottom.
10. Visually inspect the alignment of the switch. If the switch is installed properly in the rack, all the mounting screws on one side of the rack must be aligned with the mounting screws on the opposite side and the switch must be level.

Figure 56: Installing the Switch in an Open-Frame Rack

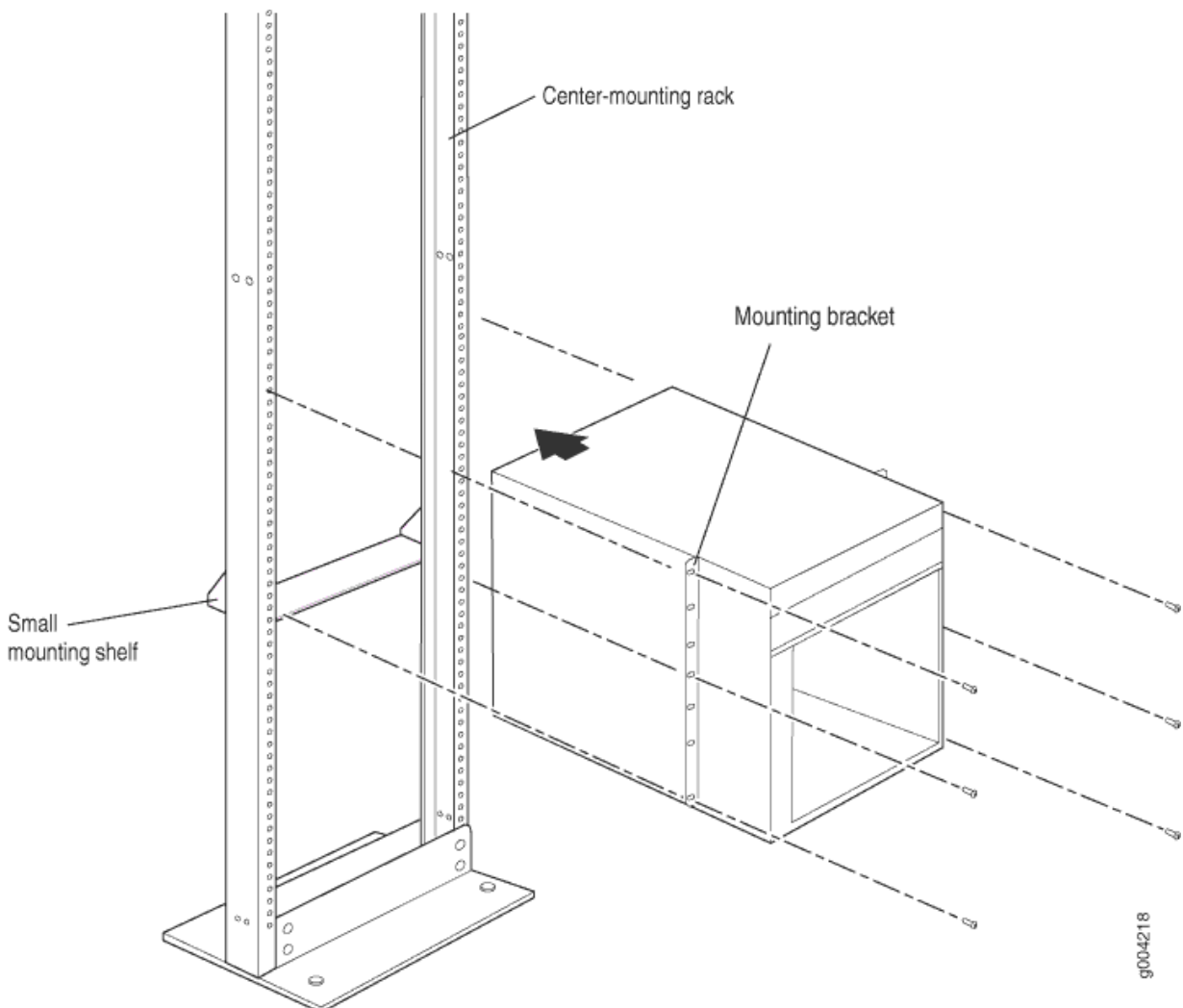

After you install the mounting screws and securely bolt the chassis to the rack, reinstall the components in the chassis. See:

- *Installing an SF Module in an EX9200 Switch*

- *Installing a Fan Tray in an EX9200 Switch*
- ["Installing an AC Power Supply in an EX9208 Switch" on page 222](#)
- ["Installing a DC Power Supply in an EX9208 Switch" on page 226](#)

Connecting the EX9208 to Power

IN THIS SECTION

- [Connect Earth Ground to an EX Series Switch | 173](#)
- [Connecting AC Power to an EX9208 Switch | 184](#)
- [Powering On an AC-Powered EX9200 Switch | 186](#)
- [Connecting DC Power to an EX9208 Switch | 187](#)
- [Powering On a DC-Powered EX9200 Switch | 192](#)

Connect Earth Ground to an EX Series Switch

IN THIS SECTION

- [Parts and Tools Required for Connecting an EX Series Switch to Earth Ground | 174](#)
- [Special Instructions to Follow Before Connecting Earth Ground to an EX Series Switch | 181](#)
- [Connecting Earth Ground to an EX Series Switch | 183](#)

To ensure proper operation and to meet safety and electromagnetic interference (EMI) requirements, you must connect an EX Series switch to earth ground before you connect power to the switch. You must use the protective earthing terminal on the switch chassis to connect the switch to earth ground (see [Figure 58 on page 183](#)).

You must install the EX Series switch in a restricted-access location and ensure that the chassis is always properly grounded. EX Series switches have a two-hole protective grounding terminal provided

on the chassis. See [Table 62 on page 174](#) for the location of the earthing terminals on various EX Series switches. Under all circumstances, use this grounding connection to ground the chassis. For AC-powered systems, you must also use the grounding wire in the AC power cord along with the two-hole grounding lug connection. This tested system meets or exceeds all applicable EMC regulatory requirements with the two-hole protective grounding terminal.

Ensure that a licensed electrician has attached an appropriate grounding lug to the grounding cable you supply. Using a grounding cable with an incorrectly attached lug can damage the switch.

Parts and Tools Required for Connecting an EX Series Switch to Earth Ground

Before you begin connecting an EX Series switch to earth ground, ensure you have the parts and tools required for your switch.

[Table 62 on page 174](#) lists the earthing terminal location, grounding cable and lug specifications, and parts needed for connecting an EX Series switch to earth ground.

Table 62: Parts Required for Connecting an EX Series Switch to Earth Ground

Switch	Earthing Terminal Location	Grounding Cable Requirements	Grounding Lug Specifications	Screws and Washers	Additional Information
EX2200	Rear panel of the chassis	14 AWG (2 mm ²), minimum 90° C wire, or as permitted by the local code	Panduit LCC10-14BWL or equivalent— not provided	<ul style="list-style-type: none"> Two 10-32 x .25 in. screws with #10 split-lock washer— not provided Two #10 flat washers— not provided 	

Table 62: Parts Required for Connecting an EX Series Switch to Earth Ground (Continued)

Switch	Earthing Terminal Location	Grounding Cable Requirements	Grounding Lug Specifications	Screws and Washers	Additional Information
EX2300-C	Rear panel of the chassis	14 AWG (2 mm ²), minimum 90° C wire, or as permitted by the local code	Panduit LCC10-14AW-L or equivalent— not provided	<ul style="list-style-type: none"> • Two 10-32 x .25 i n. screws with #10 split-lock washer— not provided • Two #10 flat washers— not provided 	

Table 62: Parts Required for Connecting an EX Series Switch to Earth Ground (Continued)

Switch	Earthing Terminal Location	Grounding Cable Requirements	Grounding Lug Specifications	Screws and Washers	Additional Information
EX2300	Rear panel of the chassis	<ul style="list-style-type: none"> EX2300 switches except EX2300-24 MP and EX2300-48 MP models—14 AWG (2 mm²), minimum 90°C wire, or as permitted by the local code EX2300-24 MP and EX2300-48 MP models—14-10 AWG STR (2.5-6 mm²), 12-10 AWG SOL (4-6 mm²) minimum 90°C wire, or as permitted by the local code—not provided 	<ul style="list-style-type: none"> EX2300 switches except EX2300-24MP and EX2300-48MP models—Panduit LCC10-14AW-L or equivalent—not provided EX2300-24MP and EX2300-48MP models—Panduit LCA10-10L or equivalent—not provided 	<ul style="list-style-type: none"> EX2300 switches except EX2300-24 MP and EX2300-48 MP models <ul style="list-style-type: none"> Two 10-32 x .25 in. screws with #10 split-lock washer—not provided Two #10 flat washers—not provided EX2300-24 MP and EX2300-48 MP models <ul style="list-style-type: none"> One Pan Phillips M 4 x 6 mm Nickel plated screw—provided 	

Table 62: Parts Required for Connecting an EX Series Switch to Earth Ground (Continued)

Switch	Earthing Terminal Location	Grounding Cable Requirements	Grounding Lug Specifications	Screws and Washers	Additional Information
EX3200 and EX3300	Rear panel of the chassis	14 AWG (2 mm ²), minimum 90° C wire, or as permitted by the local code	Panduit LCC10-14BWL or equivalent— not provided	<ul style="list-style-type: none"> Two 10-32 x .25 in. screws with #10 split-lock washer— not provided Two #10 flat washers— not provided 	For EX3200 Switches, see "Special Instructions to Follow Before Connecting Earth Ground to an EX Series Switch" on page 181.
EX3400	Rear panel of the chassis	14-10 AWG STR (2.5-6 mm ²), minimum 90° C wire, or as permitted by the local code	Panduit LCD10-10A-L or equivalent— not provided	<ul style="list-style-type: none"> Two 10-32 x .25 in. screws with #10 split-lock washer— not provided Two #10 flat washers— not provided 	
EX4200	Left side of the chassis	14 AWG (2 mm ²), minimum 90° C wire, or as permitted by the local code	Panduit LCC10-14BWL or equivalent— not provided	<ul style="list-style-type: none"> Two 10-32 x .25 in. screws with #10 split-lock washer — not provided Two #10 flat washers— not provided 	See "Special Instructions to Follow Before Connecting Earth Ground to an EX Series Switch" on page 181.

Table 62: Parts Required for Connecting an EX Series Switch to Earth Ground (Continued)

Switch	Earthing Terminal Location	Grounding Cable Requirements	Grounding Lug Specifications	Screws and Washers	Additional Information
EX4300 switches except EX4300-4 8MP and EX4300-4 8MP-S switches	Rear panel of the chassis	14-10 AWG STR (2.5-6 mm ²), minimum 90° C wire, or as permitted by the local code	Panduit LCD10-10A-L or equivalent— not provided	<ul style="list-style-type: none"> Two 10-32 x .25 in. screws with #10 split-lock washer — not provided Two #10 flat washers— not provided 	
EX4300-4 8MP and EX4300-4 8MP-S switches	Rear panel of the chassis	14-10 AWG STR (2.5-6 mm ²), minimum 90° C wire, or as permitted by the local code	Panduit LCD10-14B-L, LCC10-BW-L, or equivalent— not provided	<ul style="list-style-type: none"> Two 10-32 x .25 in. screws with #10 split-lock washer — not provided Two #10 flat washers— not provided 	
EX4500 and EX4550	Left side of the chassis	14 AWG (2 mm ²), minimum 90° C wire, or as permitted by the local code	Panduit LCC10-14BWL or equivalent— not provided	<ul style="list-style-type: none"> Two 10-32 x .25 in. screws with #10 split-lock washer — not provided Two #10 flat washers— not provided 	See "Special Instructions to Follow Before Connecting Earth Ground to an EX Series Switch" on page 181.

Table 62: Parts Required for Connecting an EX Series Switch to Earth Ground (Continued)

Switch	Earthing Terminal Location	Grounding Cable Requirements	Grounding Lug Specifications	Screws and Washers	Additional Information
EX6210	Rear panel of the chassis (on lower left side)	The grounding cable must be the same gauge as the power feed cables and as permitted by the local code.	Panduit LCD2-14A-Q or equivalent —provided	<ul style="list-style-type: none"> Two ¼ -20 x 0.5 in. screws with #¼" split-washer —provided Two #¼" flat washers— provided 	
EX8208	Left side of the chassis	6 AWG (13.3 mm ²), minimum 90° C wire, or as permitted by the local code	Panduit LCD2-14A-Q or equivalent —provided	<ul style="list-style-type: none"> Two ¼ -20 x 0.5 in. screws with #¼" split-washer —provided Two #¼" flat washers— provided 	

Table 62: Parts Required for Connecting an EX Series Switch to Earth Ground (*Continued*)

Switch	Earthing Terminal Location	Grounding Cable Requirements	Grounding Lug Specifications	Screws and Washers	Additional Information
EX8216	<p>Two earthing terminals:</p> <ul style="list-style-type: none"> • Left side of the chassis • Rear panel of the chassis <p>NOTE: You must use only one of the two protective earthing terminals.</p>	2 AWG (33.6 mm ²), minimum 90° C wire, or as permitted by the local code	Panduit LCD2-14A-Q or equivalent—provided	<ul style="list-style-type: none"> • Two ¼ -20 x 0.5 in. screws with #¼" split-washer—provided • Two #¼" flat washers—provided 	
EX9204, EX9208, and EX9214	Rear panel of the chassis	One 6 AWG (13.3 mm ²), minimum 90° C wire, or one that complies with the local code	Thomas& Betts LCN6-14 or equivalent—provided	<ul style="list-style-type: none"> • Two ¼ -20 x 0.5 in. screws with #¼" split-washer—provided • Two #¼" flat washers—provided 	See Grounding Cable and Lug Specifications for EX9200 Switches .

Table 62: Parts Required for Connecting an EX Series Switch to Earth Ground (Continued)

Switch	Earthing Terminal Location	Grounding Cable Requirements	Grounding Lug Specifications	Screws and Washers	Additional Information
EX9251	Rear panel of the chassis	12 AWG (2.5 mm ²), minimum 90° C wire, or one that complies with the local code— not provided	Panduit LCD10-10A-L or equivalent— not provided	Two 10-32 screws— provided	See Grounding Cable and Lug Specifications for EX9200 Switches .
EX9253	Right side of the chassis	14-10 AWG (2-5.3 mm ²), minimum 90° C wire, or one that complies with the local code— not provided	Panduit LCD10-14B-L or equivalent— provided	Two M5 Pan Head screws— provided	

Tools required for connecting an EX Series switch to earth ground:

- An electrostatic discharge grounding strap (provided)
- A Phillips (+) number 2 screwdriver to tighten the screws.

An AC-powered EX Series switch gains additional grounding when you plug the power supply in the switch into a grounded AC power outlet by using an AC power cord appropriate for your geographical location.

Special Instructions to Follow Before Connecting Earth Ground to an EX Series Switch

[Table 63 on page 182](#) lists the special instructions that you might need to follow before connecting earth ground to a switch.

Table 63: Special Instructions to Follow Before Connecting Earth Ground to an EX Series Switch

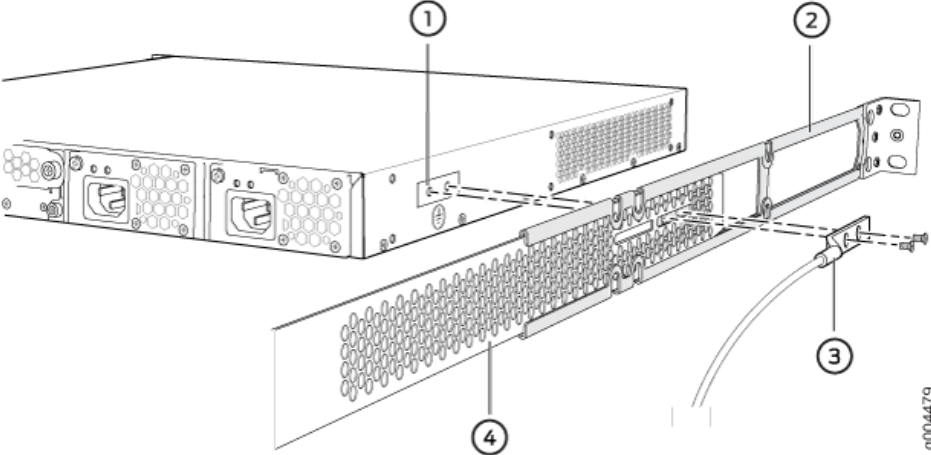
Switch	Special Instructions
EX3200 and EX4200	<p>Some early variants of EX3200 and EX4200 switches for which the Juniper Networks model number on the label next to the protective earthing terminal is from 750-021xxx through 750-030xxx require 10-24x.25 in. screws.</p>
EX4200, EX4500, and EX4550	<p>If you plan to mount your switch on four posts of a rack or cabinet, mount your switch in the rack or cabinet before attaching the grounding lug to the switch.</p> <p>NOTE: The protective earthing terminal on switches mounted on four posts of a rack is accessible through the slot on the left rear bracket only if the rack is 27.5 in. (69.85 cm) through 30.5 in. (77.47 cm) deep for a switch mounted flush with the rack front and 29.5 in. (74.93 cm) through 32.5 in. (82.55 cm) deep for a switch mounted 2 in. (5.08 cm) recessed from the rack front. See Figure 57 on page 182.</p> <p>Figure 57: Connecting the Grounding Lug to a Switch Mounted on Four Posts of a Rack</p>  <p>1– Protective earthing terminal 3– Grounding lug 2– Side mounting-rail 4– Rear mounting-blade</p> <p>NOTE: The brackets must be attached to the chassis before the grounding lug is attached. (The brackets are shown pulled away from the chassis so that the protective earthing terminal is seen.)</p>

Connecting Earth Ground to an EX Series Switch

To connect earth ground to an EX Series switch:

1. Verify that a licensed electrician has attached the cable lug to the grounding cable.
2. Connect one end of the grounding cable to a proper earth ground, such as the rack in which the switch is mounted.
3. Attach an ESD grounding strap to your bare wrist, and connect the strap to the ESD grounding point on the switch.
4. Place the grounding lug attached to the grounding cable over the protective earthing terminal. See [Figure 58 on page 183](#).

Figure 58: Connecting a Grounding Cable to an EX Series Switch

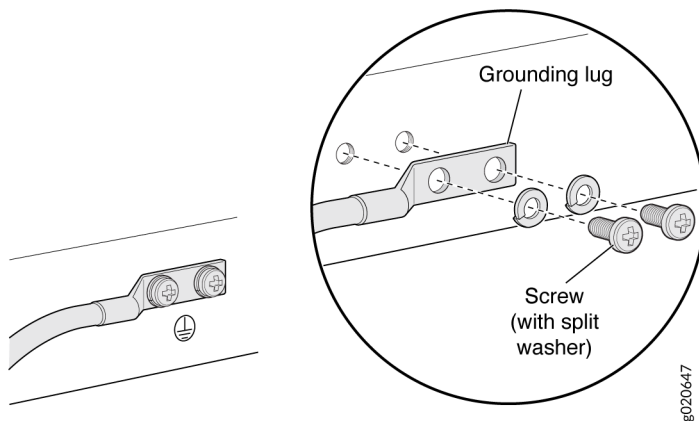

5. Secure the grounding lug to the protective earthing terminal with the washers and screws.
6. Dress the grounding cable and ensure that it does not touch or block access to other switch components and that it does not drape where people could trip over it.

SEE ALSO

General Safety Guidelines and Warnings

Grounded Equipment Warning

Connecting AC Power to an EX9208 Switch

Before you begin to connect power to the switch:

- Ensure you understand how to prevent electrostatic discharge (ESD) damage. See *Prevention of Electrostatic Discharge Damage*.
- Ensure that you have connected the device chassis to earth ground.



CAUTION: For installations that require a separate grounding conductor to the chassis, have a licensed electrician complete this connection before you connect the switch to power. For instructions on connecting earth ground, see *Connect Earth Ground to an EX Series Switch*.

- Install power supplies in the switch. See "[Installing an AC Power Supply in an EX9208 Switch](#)" on [page 222](#).

Ensure that you have the following parts and tools available to connect power to the switch:

- ESD grounding strap (provided)
- Power cords appropriate for your geographical location (not provided)

EX9208 switches can be configured with up to four AC power supplies.



CAUTION: Mixing AC and DC power supplies in the same chassis is not supported.

NOTE: Each power supply must be connected to a dedicated AC power source outlet.



WARNING: Ensure that the power cords do not block access to switch components or drape where people can trip on them.

To connect AC power to an EX9208 switch (see [Figure 59 on page 185](#)):

1. Attach the ESD grounding strap to your bare wrist, and connect the strap to the ESD point on the chassis.
2. Ensure that the power supply is fully inserted and latched securely in the chassis. See "[Installing an AC Power Supply in an EX9208 Switch](#)" on [page 222](#).

3. If needed, move the AC input switch next to the appliance inlet on the power supply faceplate, to the off (O) position.
4. Insert the coupler end of the power cord into the AC appliance inlet on the AC power supply faceplate.
5. If the AC power source outlet has a power switch, set it to the off (O) position.
6. Insert the power cord plug into an AC power source outlet.
7. If the AC power source outlet has a power switch, set it to the on (I) position.
8. Move the AC input switch next to the appliance inlet on the power supply to the on (I) position and observe the status LEDs on the power supply faceplate. If the power supply is correctly installed and functioning normally, the **AC OK** and **DC OK** LEDs glow steady green, and the **PS FAIL** LED is not lit.
9. Repeat steps 2 through 9 for the remaining power supplies.

Figure 59: Connecting the Power Supply Cord to an EX9208 Switch

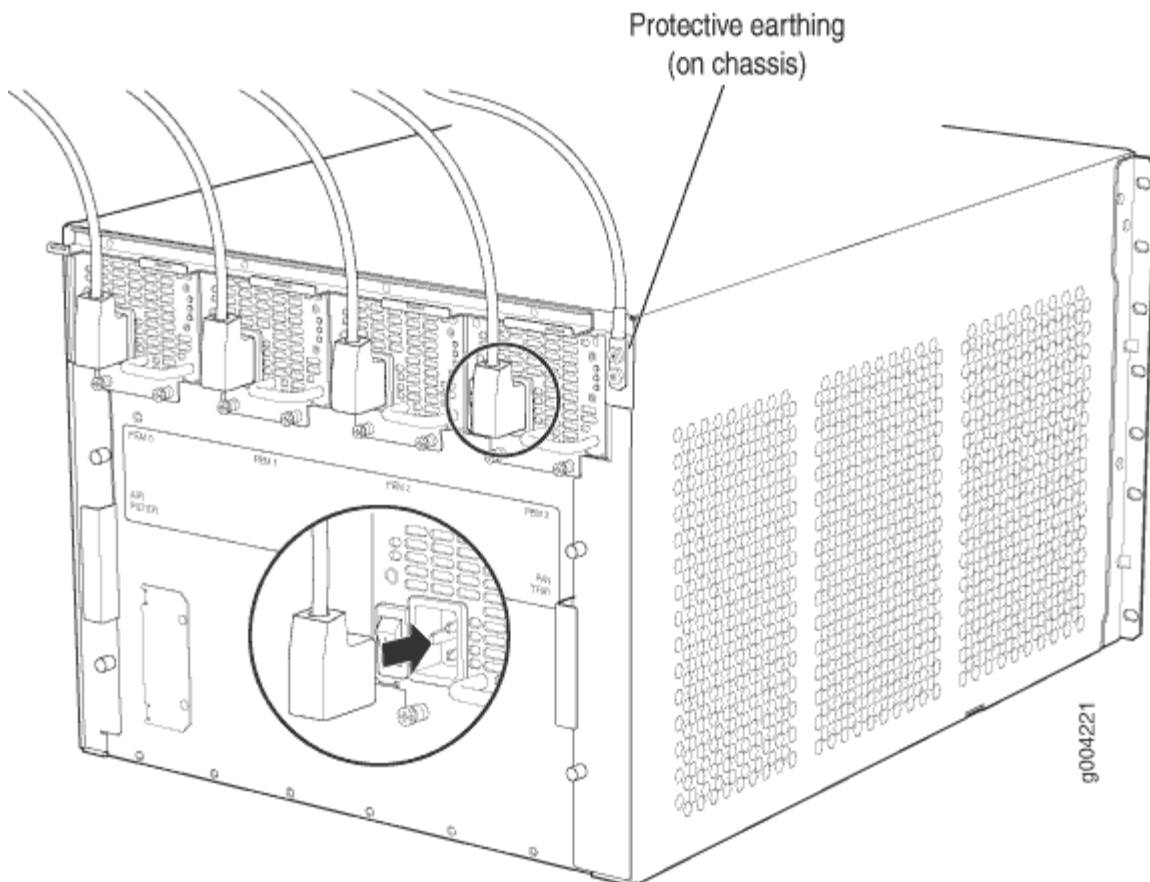

Powering On an AC-Powered EX9200 Switch

Before you power on the switch, ensure that:

- You have installed all required switch components.
- You have installed the required number of power supplies to support redundant operation for the switch configuration.
- You understand how to protect the switch from electrostatic discharge (ESD) damage . See *Prevention of Electrostatic Discharge Damage*.

Ensure that you have the following parts and tools available:

- An ESD wrist strap
- An external management device such as a PC
- A cable to connect the external management device to the **CONSOLE** port or the Ethernet management <...> port on the primary Routing Engine module (RE module).

For connecting a management device to the console port, see *Connecting an EX9200 Switch to a Management Console or an Auxiliary Device*. For connecting a management device to the Ethernet management port, see *Connecting an EX9200 Switch to a Network for Out-of-Band Management*.

To power on the switch:

1. Wrap and fasten one end of the ESD wrist strap around your bare wrist, and connect the other end of the strap to the ESD point on the switch.
2. Connect the external management device to the Ethernet management (<...>) port on the primary RE module.
3. Turn on the power to the external management device.
4. Ensure that the power supplies are fully inserted in the chassis and that each of their handles is flush against the faceplate.
5. Ensure that the source power cord is inserted securely into the appliance inlet for each AC power supply.
6. Switch on the dedicated customer site circuit breakers for the power supplies. Follow the ESD and safety instructions for your site.
7. Flip the AC input switch on the power supply to the On (I) position. Observe the power supply faceplate LEDs. If the power supply is installed correctly and functioning normally, the **AC OK** and **DC OK** LEDs glow steady green. The **PS FAIL** LED does not glow.
8. Repeat Step 7 for the remaining power supplies installed in the switch.

If any of the status LEDs indicates that the power supply is not functioning normally, repeat the installation and cabling procedures. See *Connecting AC Power to an EX9204 Switch*, "[Connecting AC Power to an EX9208 Switch](#)" on page 184, or *Connecting AC Power to an EX9214 Switch*.

9. On the external management device, monitor the startup process to ensure that the system boots properly.

NOTE: After you power on a power supply, wait for at least 60 seconds before you turn it off. After you power off a power supply, wait for at least 60 seconds before you turn it back on. If the system is completely powered off when you switch on a power supply, the RE module boots as the power supply completes its startup sequence. If the Routing Engine finishes booting and you need to power off the system again, first issue the CLI request `system halt` command.

After you power on a power supply, it can take up to 60 seconds for status indicators such as power supply LEDs and the `show chassis operational mode` CLI command display to indicate that the power supply is functioning normally. Ignore any error indicators that might appear during the first 60 seconds.

Connecting DC Power to an EX9208 Switch

Before you begin connecting DC power to an EX9208 switch:

- Ensure that you have taken the necessary precautions to prevent electrostatic discharge (ESD) damage (see *Prevention of Electrostatic Discharge Damage*).
- Ensure that you have connected the switch chassis to earth ground.



CAUTION: To meet safety and electromagnetic interference (EMI) requirements and to ensure proper operation, you must connect EX9208 switches to earth ground before you connect them to power. For installations that require a separate grounding conductor to the chassis, use the protective earthing terminal on the switch chassis to connect to earth ground. For instructions on connecting an EX9208 switch to ground using a separate grounding conductor, see *Connect Earth Ground to an EX Series Switch*.

- Install the power supply in the chassis. See "[Installing a DC Power Supply in an EX9208 Switch](#)" on page 226.

Ensure that you have the following parts and tools available to connect DC power to an EX9208 switch:

- ESD grounding strap
- DC power source cables (not provided) with the cable lugs (provided) attached.

The provided cable lugs in an EX9208 switch are sized for 6 AWG (13.3 mm²) power source cables. The DC power source cables that you provide must be 6 AWG (13.3 mm²), minimum 60°C wire. We recommend that you install heat-shrink tubing insulation around the power cables and lugs.

- 3/8-in. (9.5-mm) nut driver or socket wrench
- Phillips (+) screwdriver, number 1 and 2
- Multimeter

An EX9208 switch can be configured with up to four DC power supplies.



WARNING: Before performing DC power procedures, ensure that power is removed from the DC circuit. To ensure that all power is off, locate the circuit breaker on the panel board that services the DC circuit, switch the circuit breaker to the **OFF** position, and tape the switch handle of the circuit breaker in the **OFF** position.



CAUTION: Before you connect power to the switch, a licensed electrician must attach a cable lug to the grounding and power cables that you supply. A cable with an incorrectly attached lug can damage the switch (for example, by causing a short circuit).



CAUTION: Mixing AC and DC power supplies in the same chassis is not a supported configuration.

NOTE: Each power supply input feed must be connected to a dedicated DC power source outlet.



WARNING: Ensure that the power cords do not block access to switch components or drape where people can trip on them.

To connect DC power to an EX9208 switch:

1. Switch off the dedicated customer site circuit breakers. Ensure that the voltage across the DC power source cable leads is 0 V and that there is no chance that the cable leads might become active during installation.

2. Attach the ESD grounding strap to your bare wrist, and connect the strap to the ESD point on the chassis.
3. Move the power switch on the power supply faceplate to the off (O) position.
4. Using a screwdriver, loosen the captive screw holding the metal cover over the DIP input mode switch. Remove the metal cover from the DIP input mode switch to expose the switch.
5. Check the setting of the DIP input mode switch. Use a sharp, nonconductive object to slide the switch to the desired position. Set the input mode switch to position **0** for 60 A input and position **1** for 70 A input (see [Figure 60 on page 189](#)). This setting is used by the power management software and needs to be set before you switch on the power supply.

Figure 60: DIP Input Mode Switch

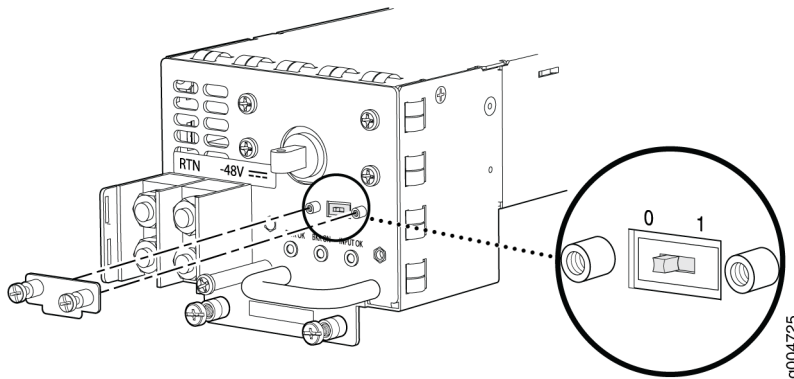

6. Install the metal cover over the DIP input mode switch, and use a screwdriver to tighten the captive screw.
7. Remove the plastic cable cover from the DC power input terminals.
8. Verify that the DC power cables are correctly labeled before making connections to the power supply. In a typical power distribution scheme where the return is connected to chassis ground at the battery plant, you can use a multimeter to verify the resistance of the **-48V** and **RTN** DC cables to chassis ground:
 - The cable with very large resistance (indicating an open circuit) to chassis ground is **-48V**.
 - The cable with very low resistance (indicating a closed circuit) to chassis ground is **RTN**.



CAUTION: You must ensure that power connections maintain the proper polarity. The power source cables might be labeled (+) and (-) to indicate their polarity. There is no standard color coding for DC power cables. The color coding used by the external DC power source at your site determines the color coding for the leads on the power cables that attach to the terminal studs on each power supply.

9. Install heat-shrink tubing insulation around the power cables.

To install heat-shrink tubing:

- a. Slide the tubing over the portion of the cable where it is attached to the lug barrel. Ensure that tubing covers the end of the wire and the barrel of the lug attached to it.
- b. Shrink the tubing with a heat gun. Ensure that you heat all sides of the tubing evenly so that it shrinks around the cable tightly.

Figure 61 on page 190 shows the steps to install heat-shrink tubing.

NOTE: Do not overheat the tubing.

Figure 61: How to Install Heat-Shrink Tubing

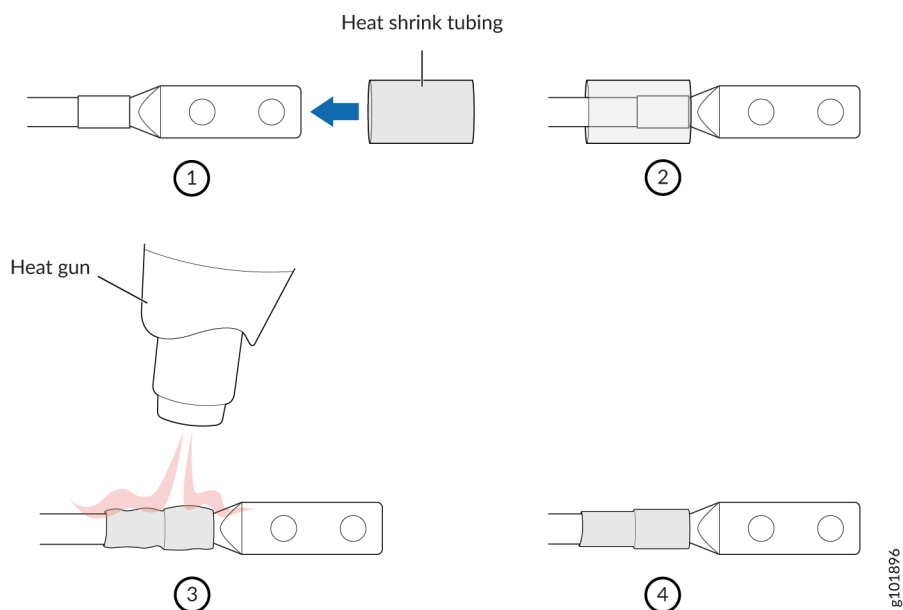

10. Remove the washers and nuts from each DC power input terminal, using a 7/16-in. [11-mm] nut driver or socket wrench.
11. Secure each power cable lug to the terminal studs, first with the flat washer, then with the split washer, and then with the nut (see Figure 62 on page 192). Apply between 23 lb-in. (2.6 Nm) and 25 lb-in. (2.8 Nm) of torque to each nut. Do not overtighten the nut. (Use a 7/16-in. [11-mm] torque-controlled driver or socket wrench.)
 - a. Secure the positive (+) DC source power cable lug to the **RTN** (return) terminal.
 - b. Secure the negative (-) DC source power cable lug to the **-48V** (input) terminal.



CAUTION: Ensure that each power cable lug seats flush against the surface of the terminal block as you are tightening the nuts. Ensure that each nut is properly threaded onto the terminal stud. You must be able to spin the nut freely with your fingers when it is first placed onto the terminal stud. Applying installation torque to the nut when improperly threaded may result in damage to the terminal stud.



CAUTION: The maximum torque rating of the terminal studs on the DC power supply is 36 lb-in. (4.0 Nm). The terminal studs may be damaged if excessive torque is applied. Use only a torque-controlled driver or socket wrench to tighten nuts on the DC power supply terminal studs.



CAUTION: The DC power supplies in **PEM0** and **PEM1** must be powered by dedicated power feeds derived from feed **A**, and the DC power supplies in **PEM2** and **PEM3** must be powered by dedicated power feeds derived from feed **B**. This configuration provides the commonly deployed **A/B** feed redundancy for the system.

For information about connecting to DC power sources, see "[DC Power Supply Specifications for EX9208 Switches](#)" on page 63.

12. Route the power cables along the cable restraint toward the left or right corner of the chassis. If needed, thread plastic cable ties, which you must provide, through the openings on the cable restraint to hold the power cables in place.
13. Replace the clear plastic cover over the terminal studs on the faceplate.
14. Verify that the power cabling is correct, that the cables are not touching or blocking access to switch components, and that they do not drape where people could trip on them.
15. Switch on the dedicated customer site circuit breakers. Follow your site's procedures for safety and ESD.

Verify that the **INPUT OK** LED on the power supply glows green.

16. On each of the DC power supplies, switch the DC circuit breaker to the center position before moving it to the on (I) position.

NOTE: The circuit breaker may bounce back to the off (O) position if you move the breaker too quickly.

Observe the status LEDs on the power supply faceplate. If the power supply is correctly installed and functioning normally, the **PWR OK**, **BRKR ON**, and **INPUT OK** LEDs glow steady green.

17. Repeat Steps 2 through 15 for the remaining power supplies.

NOTE: A Switch Fabric module must be installed for the **PWR OK** LED to function.

Figure 62: Connecting DC Power to an EX9208 switch

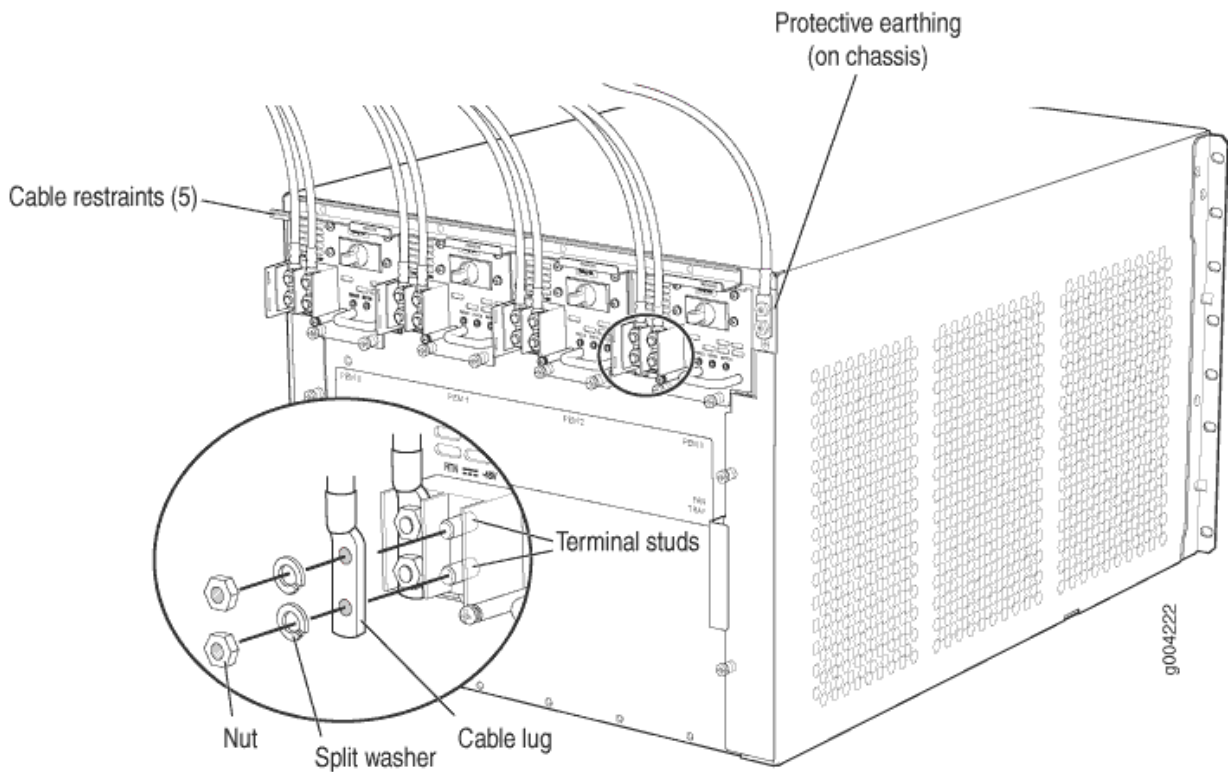

Powering On a DC-Powered EX9200 Switch

Before you power on the switch, ensure that:

- You have installed all required switch components.
- You have installed the required number of power supplies to support redundant operation for the switch configuration.

- Ensure you understand how to prevent electrostatic discharge (ESD) damage. See *Prevention of Electrostatic Discharge Damage*.

Ensure that you have the following parts and tools available:

- An ESD wrist strap
- An external management device such as a PC
- A cable to connect the external management device to the console (**CONSOLE**) port or the Ethernet management (<...>) port on the primary Routing Engine module (RE module).

For connecting a management device to the console port, see *Connecting an EX9200 Switch to a Management Console or an Auxiliary Device*. For connecting a management device to the management port, see *Connecting an EX9200 Switch to a Network for Out-of-Band Management*.

To power on the switch:

1. Connect the external management device to the primary RE module's Ethernet management (<...>) port.
2. Turn on the power to the external management device.
3. Wrap and fasten one end of the ESD wrist strap around your bare wrist, and connect the other end of the strap to the ESD point on the switch.
4. Verify that the power supplies are fully inserted in the chassis and that each of their handles is flush against the faceplate.
5. Verify that the source power cables are connected to the appropriate terminal: the positive (+) source cable to the return terminal (labeled **RTN**) and the negative (-) source cable to the input terminal (labeled **-48V**).
6. Switch on the dedicated customer site circuit breakers to provide power to the DC power cables.
7. Check the **INPUT OK** LED is lit steadily green to verify that power is present.
8. If power is not present:
 - Verify that the fuse is installed correctly and turn on the breaker at the battery distribution fuse board or fuse bay.
 - Check the voltage with a meter at the terminals of the power supply for correct voltage level and polarity.
9. On each of the DC power supplies, switch the DC circuit breaker to the center position before moving it to the On (—) position.

NOTE: The circuit breaker might bounce back to the Off **O**) position if you move the breaker too quickly.

If any of the status LEDs indicates that the power supply is not functioning normally, repeat the installation and cabling procedures. See *Connecting DC Power to an EX9204 Switch*, "[Connecting DC Power to an EX9208 Switch](#)" on page 187, or *Connecting DC Power to an EX9214 Switch*.

10. Verify that the **BREAKER ON** LED glows steady green.
11. Verify that the **PWR OK** LED glows steady green, indicating the power supply is correctly installed and functioning normally.

If the power supply is not functioning normally, repeat the installation and cabling procedures.

NOTE: After powering off a power supply, wait for at least 60 seconds before turning it back on. After powering on a power supply, wait for at least 60 seconds before turning it off.

If the system is completely powered off when you power on the power supply, the Routing Engine boots as the power supply completes its startup sequence. If the Routing Engine finishes booting and you need to power off the system again, first issue the CLI request `system halt` command.

After a power supply is powered on, it can take up to 60 seconds for status indicators—such as the status LEDs on the power supply and the `show chassis` command display—to indicate that the power supply is functioning normally. Ignore error indicators that appear during the first 60 seconds.

12. On the external management device connected to the Routing Engine, monitor the startup process to verify that the system has booted properly.

Connecting the EX9200 to External Devices

IN THIS SECTION

- [Connecting an EX9200 Switch to a Network for Out-of-Band Management | 195](#)
- [Connecting an EX9200 Switch to a Management Console or an Auxiliary Device | 196](#)
- [Connecting the EX9200 Switch to an External Alarm-Reporting Device | 197](#)

Connecting an EX9200 Switch to a Network for Out-of-Band Management

Ensure that you have an Ethernet cable with an RJ-45 connector available. [Figure 63 on page 195](#) shows the RJ-45 connector of the Ethernet cable supplied with the switch.

Figure 63: Ethernet Cable Connector

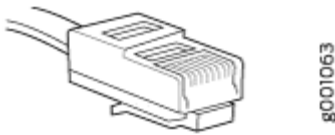

You can monitor and manage an EX9200 switch by using a dedicated management channel. Each switch has an Ethernet management port labeled with an RJ-45 connector for out-of-band management. Use the Ethernet management port to connect the EX9200 switch to the management device.

To connect a switch to a network for out-of-band management:

1. Turn off the power to the management device.
2. Connect one end of the Ethernet cable to the management port.
 - In an EX9200 switch, the management port is on the Routing Engine module (RE module) installed in the switch and is labeled **ETHERNET** (see [Figure 64 on page 195](#)).

Figure 64: Management Port on the RE Module in an EX9200 Switch

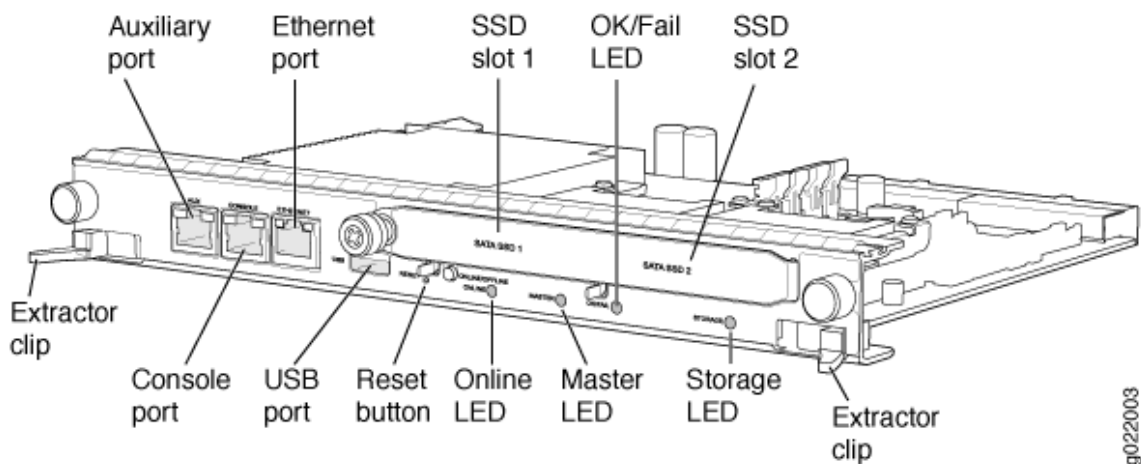

3. Connect the other end of the Ethernet cable to the management device.

Connecting an EX9200 Switch to a Management Console or an Auxiliary Device

Ensure that you have an Ethernet cable with an RJ-45 connector available.

Figure 65 on page 196 shows the RJ-45 connector of the Ethernet cable supplied with the switch.

Figure 65: Ethernet Cable Connector

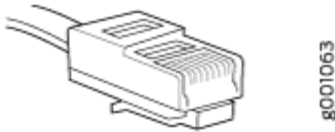

NOTE: If your laptop or PC does not have a DB-9 plug connector pin and you want to connect your laptop or PC directly to the device, use a combination of the RJ-45 to DB-9 socket adapter and a USB to DB-9 plug adapter. You must provide the USB to DB-9 plug adapter.

NOTE: We no longer include the RJ-45 console cable with the DB-9 adapter as part of the device package. If the console cable and adapter are not included in your device package, or if you need a different type of adapter, you can order the following separately:

- RJ-45 to DB-9 adapter (JNP-CBL-RJ45-DB9)
- RJ-45 to USB-A adapter (JNP-CBL-RJ45-USBA)
- RJ-45 to USB-C adapter (JNP-CBL-RJ45-USBC)

If you want to use RJ-45 to USB-A or RJ-45 to USB-C adapter you must have X64 (64-Bit) Virtual COM port (VCP) driver installed on your PC. See, <https://ftdichip.com/drivers/vcp-drivers/> to download the driver.

To use a system console to configure and manage the Routing Engine, connect it to the appropriate Console port labeled **CONSOLE** on the Routing Engine module (RE module) in an EX9200 switch. To use a laptop, modem, or other auxiliary device, connect it to the auxiliary (labeled **AUX**) port on the RE module or front panel. Both ports accept a cable with an RJ-45 connector. To connect a device to the console port and another device to the auxiliary port, you must supply two separate cables.

To connect the device to a management console or auxiliary device:

1. Turn off the power to the console or auxiliary device.
2. Plug the RJ-45 end of the serial cable into the auxiliary port or console port on an EX9200 switch.
[Figure 66 on page 197](#) shows location of **AUX** and **CONSOLE** ports on an RE module in an EX9200 switch.

Figure 66: Console and Auxiliary Ports on the RE Module in an EX9200 Switch

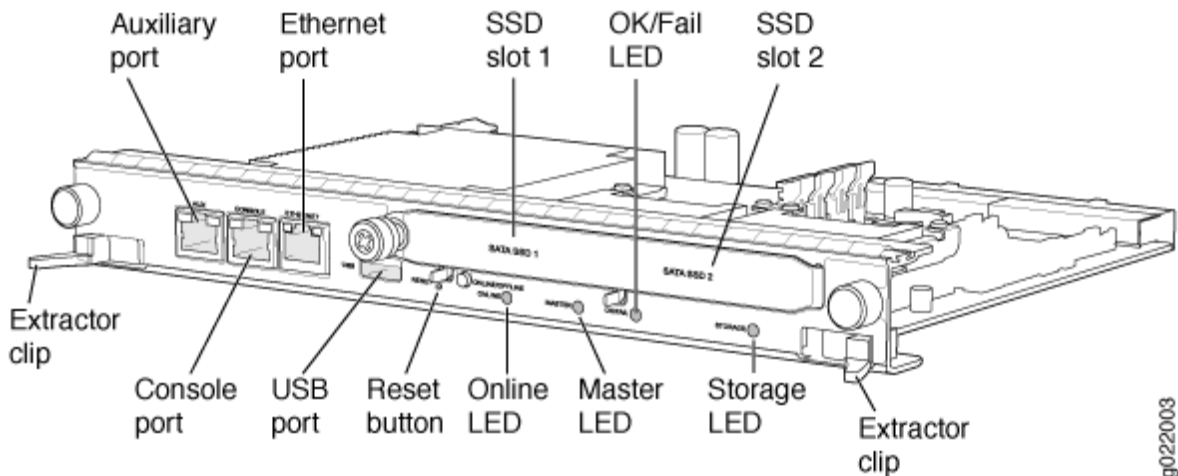

3. Plug the socket DB-9 end into the serial port of the switch.

Connecting the EX9200 Switch to an External Alarm-Reporting Device

To connect the switch to external alarm-reporting devices, attach wires to the **MAJOR ALARM** and **MINOR ALARM** relay contacts on the craft interface. See [Figure 67 on page 198](#). A system condition that triggers the major or minor alarm LED on the craft interface also activates the corresponding alarm relay contact.

The terminal blocks that plug into the alarm relay contacts are supplied with the switch. They accept wire of any gauge between 28 AWG (0.08 mm²) and 14 AWG (2.08 mm²), which is not provided. Use the gauge of wire appropriate for the external device you are connecting.

To connect an external device to an alarm relay contact (see [Figure 67 on page 198](#)):

1. Prepare the required length of wire with gauge between 28 AWG (0.08 mm²) and 14 AWG (2.08 mm²).
2. While the terminal block is not plugged into the relay contact, use a 2.5 mm flat-blade screwdriver to loosen the small screws on its side. With the small screws on its side facing left, insert wires into the slots in the front of the block based on the wiring for the external device. Tighten the screws to secure the wire.

3. Plug the terminal block into the relay contact, and use a 2.5-mm flat-blade screwdriver to tighten the screws on the face of the block.
4. Attach the other end of the wires to the external device.

To attach a reporting device for the other kind of alarm, repeat the procedure.

Figure 67: Alarm Relay Contacts

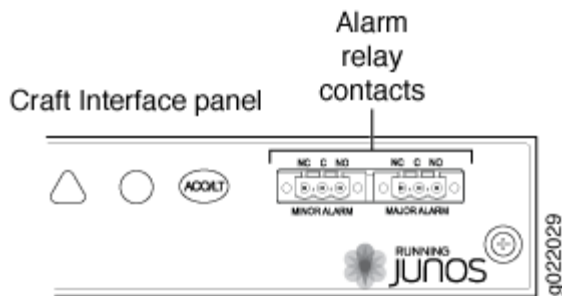

Connecting the EX9200 to the Network

IN THIS SECTION

- [Install a Transceiver | 198](#)
- [Connect a Fiber-Optic Cable | 202](#)

Install a Transceiver

Before you install a transceiver in a device, ensure that you have taken the necessary precautions for safe handling of lasers (see [Laser and LED Safety Guidelines and Warnings](#)).

Ensure that you have a rubber safety cap available to cover the transceiver.

The transceivers for Juniper Networks devices are hot-removable and hot-insertable field-replaceable units (FRUs). You can remove and replace the transceivers without powering off the device or disrupting the device functions.

NOTE: After you insert a transceiver or after you change the media-type configuration, wait for 6 seconds for the interface to display operational commands.

NOTE: We recommend that you use only optical transceivers and optical connectors purchased from Juniper Networks with your Juniper Networks device.



CAUTION: The Juniper Networks Technical Assistance Center (JTAC) provides complete support for Juniper-supplied optical modules and cables. However, JTAC does not provide support for third-party optical modules and cables that are not qualified or supplied by Juniper Networks. If you face a problem running a Juniper device that uses third-party optical modules or cables, JTAC may help you diagnose host-related issues if the observed issue is not, in the opinion of JTAC, related to the use of the third-party optical modules or cables. Your JTAC engineer will likely request that you check the third-party optical module or cable and, if required, replace it with an equivalent Juniper-qualified component.

Use of third-party optical modules with high-power consumption (for example, coherent ZR or ZR+) can potentially cause thermal damage to or reduce the lifespan of the host equipment. Any damage to the host equipment due to the use of third-party optical modules or cables is the users' responsibility. Juniper Networks will accept no liability for any damage caused due to such use.

Figure 68 on page 201 shows how to install a QSFP+ transceiver. The procedure is the same for all types of transceivers except the QSFP28 and CFP transceivers.

To install a transceiver:



CAUTION: To prevent electrostatic discharge (ESD) damage to the transceiver, do not touch the connector pins at the end of the transceiver.

1. Wrap and fasten one end of the ESD wrist strap around your bare wrist, and connect the other end of the strap to the ESD point on the switch.
2. Remove the transceiver from its bag.
3. Check to see whether the transceiver is covered with a rubber safety cap. If it is not, cover the transceiver with a rubber safety cap.



LASER WARNING: Do not leave a fiber-optic transceiver uncovered except when inserting or removing a cable. The rubber safety cap keeps the port clean and protects your eyes from accidental exposure to laser light.

4. If the port in which you want to install the transceiver is covered with a dust cover, remove the dust cover and save it in case you need to cover the port later. If you are hot-swapping a transceiver, wait for at least 10 seconds after removing the transceiver from the port before installing a new transceiver.
5. Using both hands, carefully place the transceiver in the empty port. The connectors must face the chassis.



CAUTION: Before you slide the transceiver into the port, ensure that the transceiver is aligned correctly. Misalignment might cause the pins to bend, making the transceiver unusable.

6. Slide the transceiver in gently until it is fully seated. If you are installing a CFP transceiver, use your fingers to tighten the captive screws on the transceiver.
7. Remove the rubber safety cap from the transceiver and the end of the cable, and insert the cable into the transceiver.



LASER WARNING: Do not look directly into a fiber-optic transceiver or into the ends of fiber-optic cables. Fiber-optic transceivers and fiber-optic cable connected to a transceiver emit laser light that can damage your eyes.



CAUTION: Do not leave a fiber-optic transceiver uncovered except when inserting or removing cable. The safety cap keeps the port clean and protects your eyes from accidental exposure to laser light.

8. If there is a cable management system, arrange the cable in the cable management system to prevent the cable from dislodging or developing stress points. Secure the cable so that it does not support its own weight as it hangs toward the floor. Place excess cable out of the way in a neatly coiled loop in the cable management system. Placing fasteners on the loop helps to maintain its shape.

CAUTION: Do not let fiber-optic cable hang free from the connector. Do not allow fastened loops of cable to dangle, which stresses the cable at the fastening point.

CAUTION: Avoid bending fiber-optic cable beyond its minimum bend radius. An arc smaller than a few inches in diameter can damage the cable and cause problems that are difficult to diagnose.

NOTE: When you install SFP-DD transceivers, push it hard until you hear a click sound. Use a long nose plier to pull the SFP-DD transceiver connected on the top and bottom rows of the chassis where the pull tabs face each other.

NOTE: Make sure to use a dust cap to cover ports that are unused.

NOTE: While using Finisar AOC SFP+ optical module with the QFX5130-48C switch, you may need to pull the module upwards to pull out the module smoothly from the cage.

NOTE: "

Figure 68: Install a Transceiver

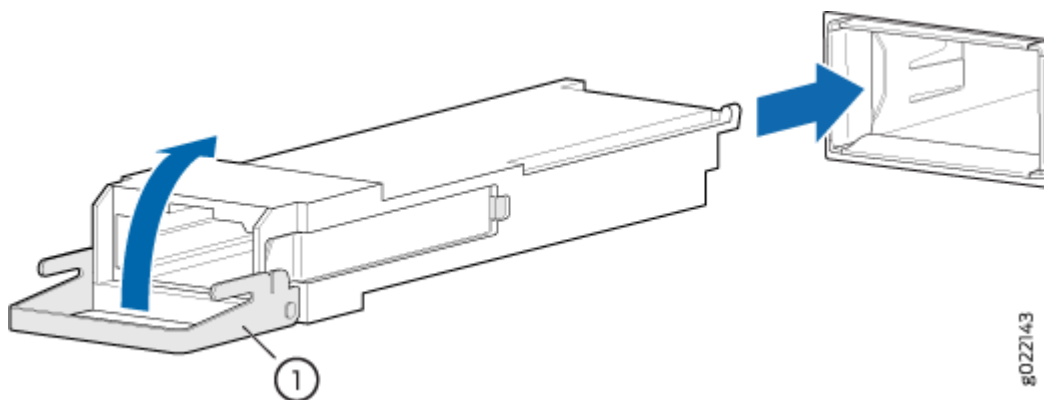

Connect a Fiber-Optic Cable

Before you connect a fiber-optic cable to an optical transceiver installed in a device, ensure that you have taken the necessary precautions for safe handling of lasers (see *Laser and LED Safety Guidelines and Warnings*).

To connect a fiber-optic cable to an optical transceiver installed in a device:



LASER WARNING: Do not look directly into a fiber-optic transceiver or into the ends of fiber-optic cables. Fiber-optic transceivers and fiber-optic cables connected to transceivers emit laser light that can damage your eyes.

1. If the fiber-optic cable connector is covered with a rubber safety cap, remove the cap. Save the cap.
2. Remove the rubber safety cap from the optical transceiver. Save the cap.
3. Insert the cable connector into the optical transceiver (see [Figure 69 on page 202](#)).

Figure 69: Connect a Fiber-Optic Cable to an Optical Transceiver Installed in a Device

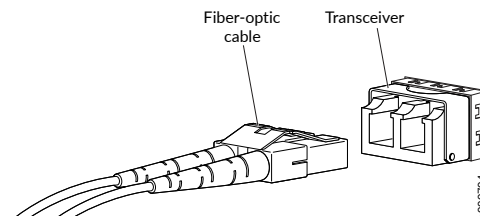

4. Secure the cables so that they do not support their own weight. Place excess cable out of the way in a neatly coiled loop. Placing fasteners on a loop helps cables maintain their shape.



CAUTION: Do not bend fiber-optic cables beyond their minimum bend radius. An arc smaller than a few inches in diameter can damage the cables and cause problems that are difficult to diagnose.

Do not let fiber-optic cables hang free from the connector. Do not allow fastened loops of cables to dangle, which stresses the cables at the fastening point.

Configuring Junos OS on the EX9200

IN THIS SECTION

- [EX9200 Switch Default Configuration | 203](#)
- [Connecting and Configuring an EX9200 Switch \(CLI Procedure\) | 204](#)

EX9200 Switch Default Configuration

Each EX9200 switch is programmed with a factory default configuration that contains the values set for each configuration parameter when a switch is shipped. The default configuration file sets values for system parameters such as the Address Resolution Protocol (ARP) aging timer, the system log, and file messages, while also enabling the Link Layer Discovery Protocol (LLDP) protocol, the Rapid Spanning Tree Protocol (RSTP), Internet Group Management Protocol (IGMP) snooping, and storm control.

When you commit changes to the configuration, a new configuration file is created that becomes the active configuration. You can always revert to the factory default configuration. See *Reverting to the Default Factory Configuration for the EX Series Switch*.

This topic shows the factory default configuration file of an EX9200 switch.

```
system {
  arp {
    aging-timer 5;
  }
  syslog {
    user * {
      any emergency;
    }
    file messages {
      any notice;
      authorization info;
    }
    file interactive-commands {
      interactive-commands any;
    }
  }
}
```

```
}  
protocols {  
  lldp {  
    interface all;  
  }  
}
```

Connecting and Configuring an EX9200 Switch (CLI Procedure)

The EX9200 switch is shipped with the Junos OS preinstalled and ready to be configured when the switch is powered on. There are three copies of the software: one on a CompactFlash card in the Routing Engine module (RE module), one on a rotating hard disk in the RE module, and one on a USB flash drive that can be inserted into the slot in the faceplate of the RE module.

When the switch boots, it first attempts to start the image on the USB flash drive. If there is no USB flash drive inserted into the RE module or if the attempt otherwise fails, the switch next attempts to start the software from the CompactFlash card (if installed), and finally from the hard disk.

You configure the switch by issuing Junos OS command-line interface (CLI) commands, either on a console device attached to the console (**CONSOLE**) port on the primary RE module, or over a telnet connection to a network connected to the Ethernet management (<...>) port on the primary RE module.

Gather the following information before configuring the switch:

- Name the switch will use on the network
- Domain name the switch will use
- IP address and prefix length information for the Ethernet interface
- IP address of a default switch
- IP address of a DNS server
- Password for the root user

This procedure connects the switch to the network, but does not enable it to forward traffic. For complete information about enabling the switch to forward traffic, including examples, see the Junos OS configuration guides.

To configure the software:

1. Verify that the switch is powered on.
2. Log in as the *root* user. There is no password.

3. Start the CLI.

```
root# cli
root@>
```

4. Enter configuration mode.

```
cli> configure
[edit]
root@#
```

5. Set the root authentication password by entering either a clear-text password, an encrypted password, or an SSH public key string (DSA or RSA).

```
[edit]
root@# set system root-authentication plain-text-password
New password: password
Retype new password: password
```

or

```
[edit]
root@# set system root-authentication encrypted-password encrypted-password
```

or

```
[edit]
root@# set system root-authentication ssh-dsa public-key
```

or

```
[edit]
root@# set system root-authentication ssh-rsa public-key
```

6. Configure the name of the switch. If the name includes spaces, enclose the name in quotation marks (" ").

```
[edit]
root@# set system host-name host-name
```

7. Create a user account.

```
[edit]
root@# set system login user user-name authentication plain-text-password
New password: password
Retype new password: password
```

8. Set the user account class to super-user.

```
[edit]
root@# set system login user user-name class super-user
```

9. Configure the switch's domain name.

```
[edit]
root@# set system domain-name domain-name
```

10. Configure the IP address and prefix length for the switch's Ethernet interface.

```
[edit]
root@# set interfaces fxp0 unit 0 family inet address address/prefix-length
```

11. Configure the IP address of a DNS server.

```
[edit]
root@# set system name-server address
```

12. (Optional) Configure the static routes to remote subnets with access to the management port. Access to the management port is limited to the local subnet. For more information about static routes, see the [Junos OS Administration Library for Routing Devices](#).

```
[edit]
root@# set routing-options static route remote-subnet next-hop destination-IP retain no-
readvertise
```

13. Configure the telnet service at the [edit system services] hierarchy level.

```
[edit]
root@# set system services telnet
```

14. (Optional) Display the configuration to verify that it is correct.

```
[edit]
root@# show
system {
  host-name host-name;
  domain-name domain-name;
  root-authentication {
    authentication-method (password | public-key);
  }
  name-server {
    address;
  }
}
interfaces {
  fxp0 {
    unit 0 {
      family inet {
        address address/prefix-length;
      }
    }
  }
}
}
```

15. Commit the configuration to activate it on the switch.

```
[edit]
root@# commit
```

16. (Optional) Configure additional properties by adding the necessary configuration statements. Then commit the changes to activate them on the switch.

```
[edit]
root@switch# commit
```

17. When you have finished configuring the switch, exit configuration mode.

```
[edit]
root@switch# exit
root@switch>
```

NOTE: To reinstall Junos OS, you boot the switch from the removable media. Do not insert the removable media during normal operations. The switch does not operate normally when it is booted from the removable media.

When the switch boots from the storage media (removable media, CompactFlash card, or hard disk) it expands its search in the /config directory of the routing platform for the following files in the following order: juniper.conf (the main configuration file), rescue.conf (the rescue configuration file), and juniper.conf.1 (the first rollback configuration file). When the first configuration file is found that can be loaded properly, the search ends and the file is loaded. If none of the file can be loaded properly, the routing platform does not function properly. If the switch boots from an alternate boot device, Junos OS displays a message indication this when you log in to the switch.

5

CHAPTER

Maintaining Components

Routine Maintenance Procedures for EX9200 Switches | 210

Maintaining the EX9200 Cooling System | 210

Maintaining the EX9208 Power System | 220

Maintaining the EX9200 Host Subsystem | 230

Maintaining the EX9200 Line Cards | 251

Maintain Transceivers | 269

Maintaining Alarm Relay Wire | 276

Maintain Fiber-Optic Cables | 278

Maintaining the EX9208 Cable Management Brackets | 281

Removing an EX9208 from a Rack or Cabinet | 283

Routine Maintenance Procedures for EX9200 Switches

IN THIS SECTION

- [Purpose | 210](#)
- [Action | 210](#)

Purpose

For optimum performance of an EX9200 switch, perform preventive maintenance procedures.

Action

- Inspect the installation site for moisture, loose wires or cables, and excessive dust. Make sure that airflow is unobstructed around the switch and into the air intake vents.
- Check the status-reporting devices on the craft interface in EX9200 switches—system alarms and LEDs.
- Inspect the air filter or fan tray at the rear of the switch, replacing it every 6 months for optimum cooling system performance. Do not run the switch for more than a few minutes without the air filter or fan tray in place.

Maintaining the EX9200 Cooling System

IN THIS SECTION

- [Removing a Fan Tray from an EX9200 Switch | 211](#)

- [Installing a Fan Tray in an EX9200 Switch | 213](#)
- [Maintaining the Fan Tray in EX9200 Switches | 217](#)
- [Maintaining the Air Filter in EX9200 Switches | 219](#)

Removing a Fan Tray from an EX9200 Switch

Before you remove a fan tray:

- Ensure you understand how to prevent electrostatic discharge (ESD) damage. See *Prevention of Electrostatic Discharge Damage*.

Ensure that you have the following parts and tools available:

- ESD grounding strap
- Phillips (+) screwdrivers, number 1 and 2
- Replacement fan tray

The fan tray in an EX9200 switch is a hot-insertable and hot-removable field-replaceable unit (FRU): You can remove and replace it while the switch is running without turning off power to the switch or disrupting switching functions.



CAUTION: Do not remove the fan tray unless you have a replacement fan tray available.

To remove a fan tray from an EX9200 switch chassis:

1. Attach the ESD grounding strap to your bare wrist, and connect the strap to the ESD point on the chassis.
2. Loosen the captive screws on the fan tray faceplate using a screwdriver.
3. Grasp the fan tray handle, and pull it out approximately 1 to 3 inches.
4. Press the latch located on the inside of the fan tray to release it from the chassis.
5. Place one hand under the fan tray to support it, and pull the fan tray completely out of the chassis.

[Figure 70 on page 212](#) shows removing a fan tray from an EX9208 switch. The procedure and orientation of the fan tray are the same for EX9204. The procedure is the same for EX9214 switch; however, the

orientation of the fan tray is different— it is installed horizontally into the top and bottom of the chassis (see [Figure 71 on page 213](#)).

Figure 70: Removing a Fan Tray from an EX9200 Switch

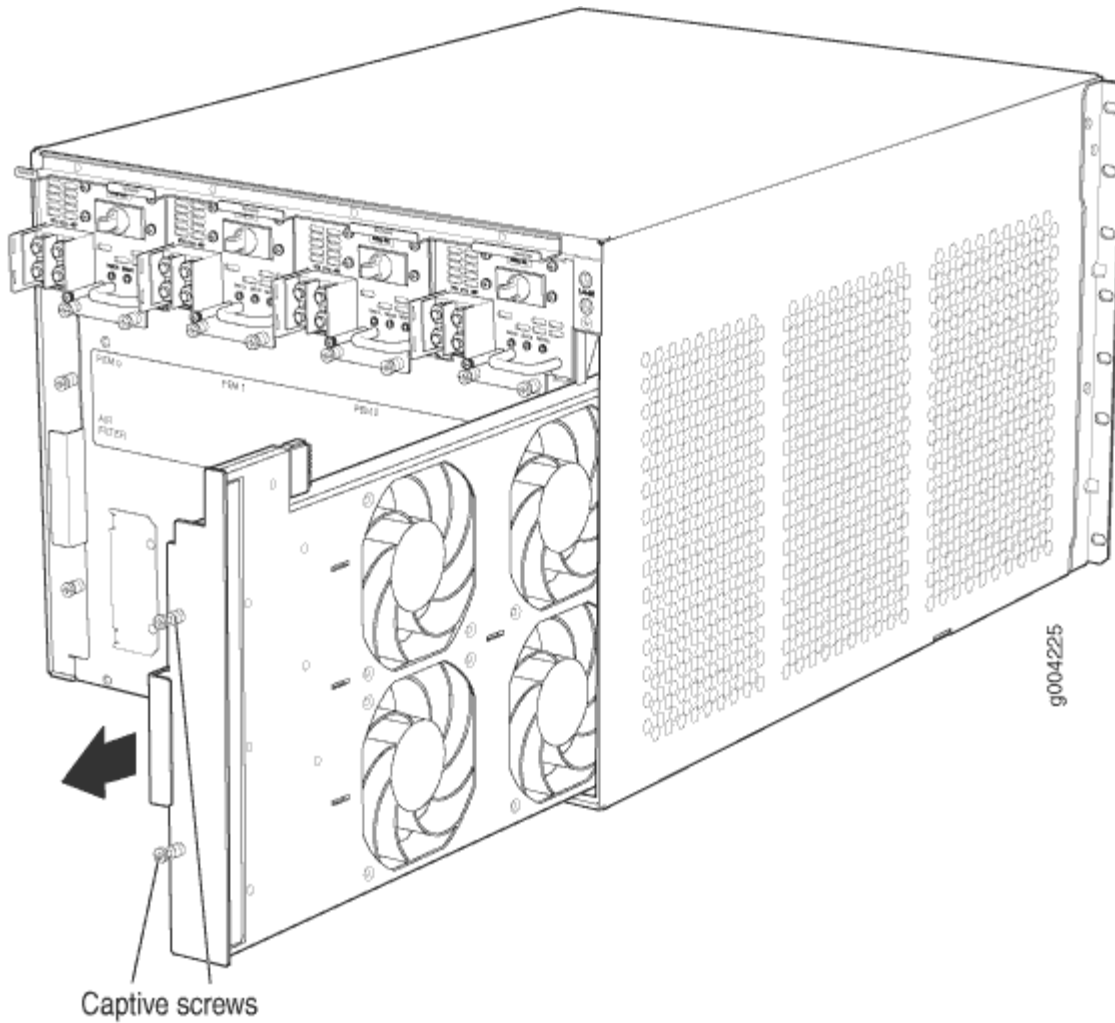
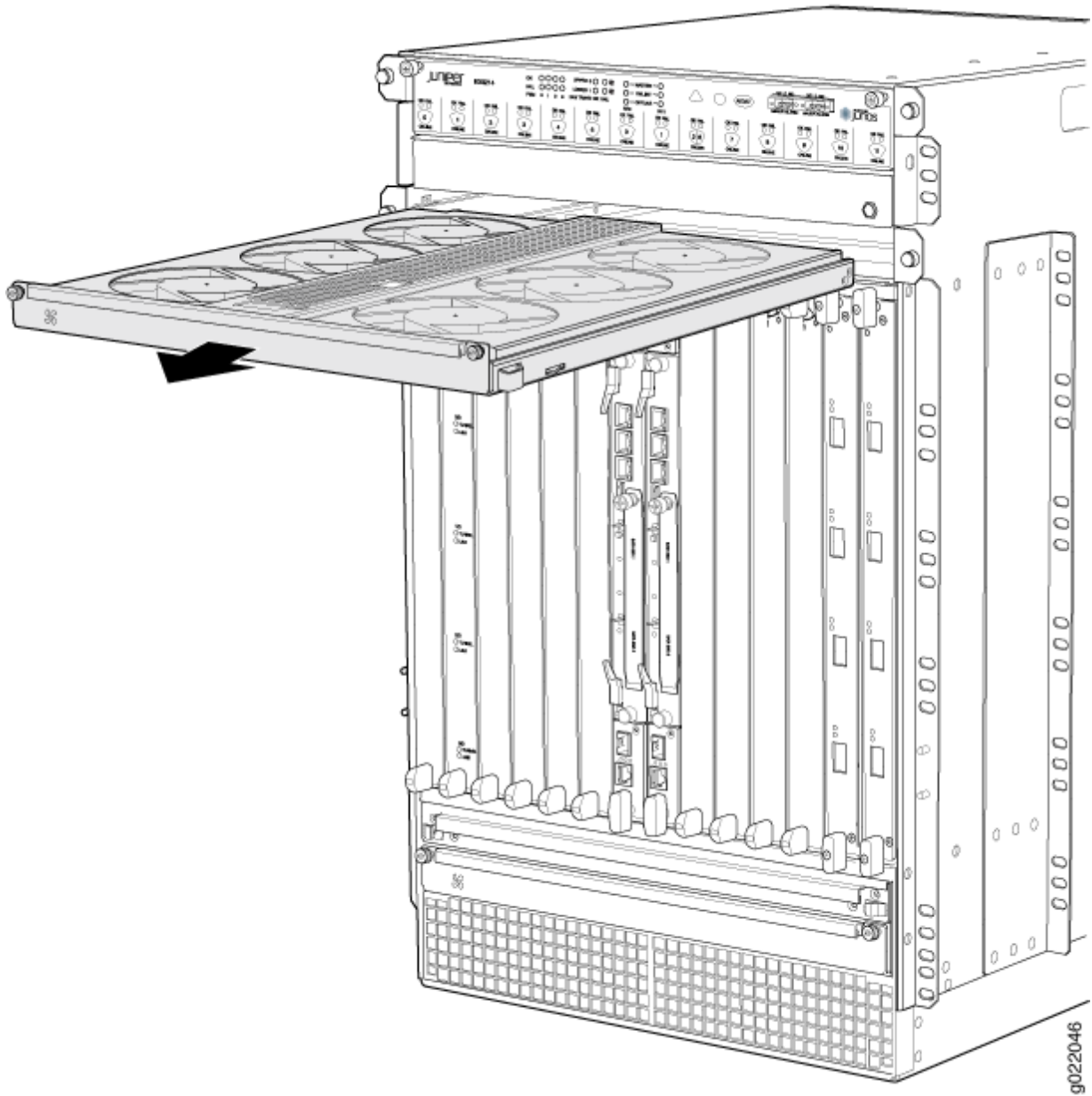

Figure 71: Removing the Upper Fan Tray in an EX9214 Switch



Installing a Fan Tray in an EX9200 Switch

Before you begin to install a fan tray:

- Ensure you understand how to prevent electrostatic discharge (ESD) damage. See *Prevention of Electrostatic Discharge Damage*.

Ensure that you have the following parts and tools available:

- ESD grounding strap
- Phillips (+) screwdrivers, number 1 and 2



CAUTION: The fan tray can be removed and replaced while the switch is operating. However, the fan tray must be replaced within 2 minutes of removing the fan tray to prevent the chassis from overheating.

The fan tray in an EX9200 switch is a hot-insertable and hot-removable field-replaceable unit (FRU): You can remove and replace it while the switch is running without turning off power to the switch or disrupting switching functions.

To install a fan tray in an EX9200 switch:

1. Attach the ESD grounding strap to your bare wrist, and connect the strap to the ESD point on the chassis.
2. Grasp the fan tray handle, and insert it straight into the chassis. Note the correct orientation by the **This side up** label on the top surface of the fan tray.
3. Tighten the captive screws using a screwdriver on the fan tray faceplate to secure it in the chassis.

[Figure 72 on page 215](#) shows installing a fan tray in an EX9208 switch. The procedure and orientation of the fan tray are the same for EX9204. The procedure is the same for EX9214 switch; however, the orientation of the fan tray is different—it is installed horizontally into the top and bottom of the chassis (see [Figure 73 on page 216](#)).

Figure 72: Installing a Fan Tray in an EX9208 Switch

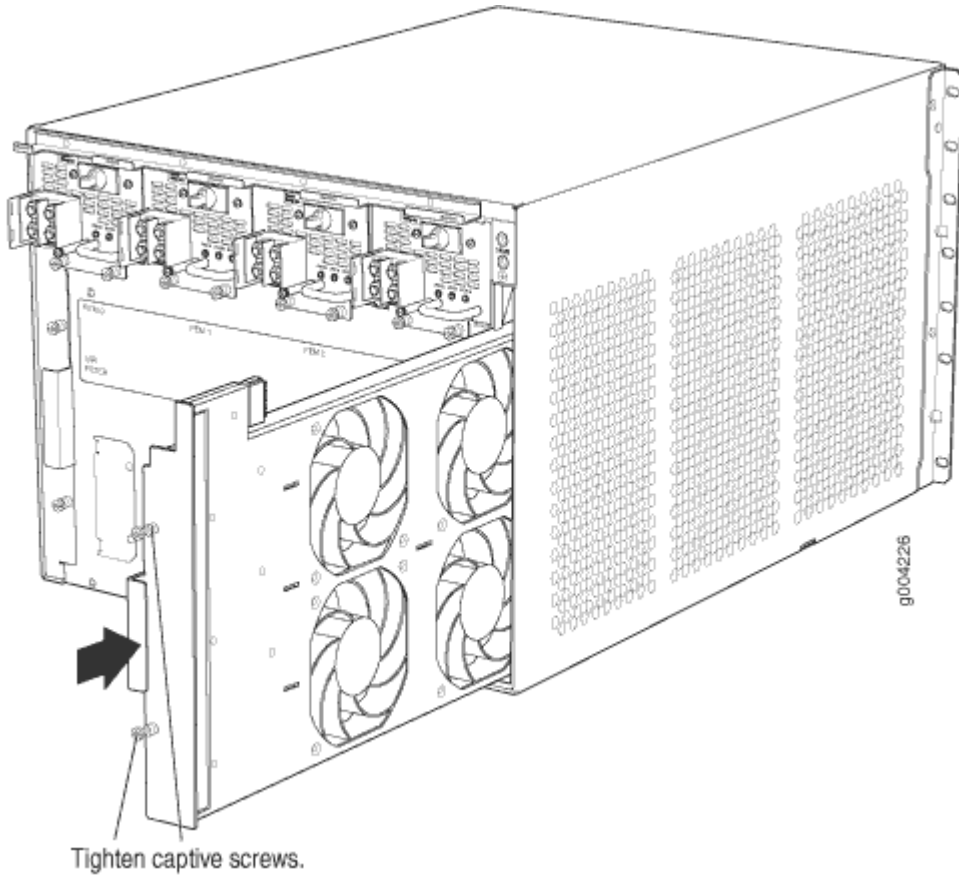
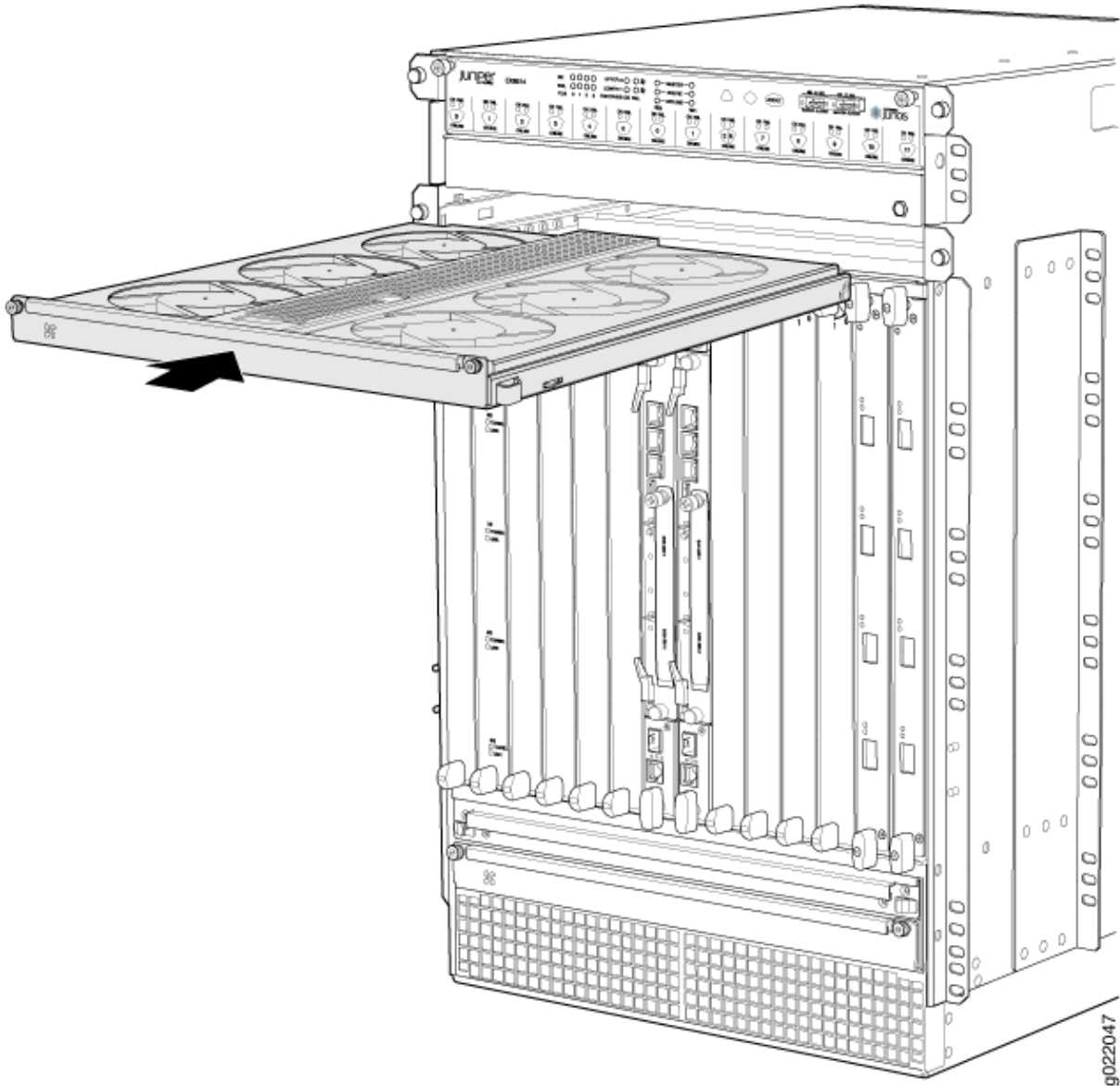

Figure 73: Installing the Upper Fan Tray in an EX9214 Switch



NOTE: If you have a Juniper J-Care service contract, register any addition, change, or upgrade of hardware components at <https://www.juniper.net/customers/support/tools/updateinstallbase/>. Failure to do so can result in significant delays if you need replacement parts. This note does not apply if you replace existing components with the same type of component.

Maintaining the Fan Tray in EX9200 Switches

IN THIS SECTION

- Purpose | 217
- Action | 217

Purpose

For optimum cooling, verify the condition of the fans.

Action

- Monitor the status of the fans. A fan tray contains multiple fans that work in unison to cool the switch components. If one fan fails, the host subsystem adjusts the speed of the remaining fans to maintain proper cooling. A major alarm is triggered when a fan fails and a minor alarm and a major alarm are triggered when a fan tray is removed.
- To display the status of the cooling system, issue the `show chassis environment` command. The output is similar to the following:

```
user@switch> show chassis environment
Class Item                Status      Measurement
Temp PEM 0                 OK          30 degrees C / 86 degrees F
      PEM 1                 OK          35 degrees C / 95 degrees F
      PEM 2                 Check
      PEM 3                 Absent
Routing Engine 0          OK          31 degrees C / 87 degrees F
Routing Engine 0 CPU      OK          30 degrees C / 86 degrees F
Routing Engine 1          OK          33 degrees C / 91 degrees F
Routing Engine 1 CPU      OK          31 degrees C / 87 degrees F
CB 0 Intake               OK          30 degrees C / 86 degrees F
CB 0 Exhaust A           OK          29 degrees C / 84 degrees F
CB 0 Exhaust B           OK          36 degrees C / 96 degrees F
CB 0 ACBC                 OK          34 degrees C / 93 degrees F
CB 0 XF A                 OK          50 degrees C / 122 degrees F
CB 0 XF B                 OK          46 degrees C / 114 degrees F
CB 1 Intake               OK          30 degrees C / 86 degrees F
```

CB 1 Exhaust A	OK	29 degrees C / 84 degrees F
CB 1 Exhaust B	OK	37 degrees C / 98 degrees F
CB 1 ACBC	OK	33 degrees C / 91 degrees F
CB 1 XF A	OK	50 degrees C / 122 degrees F
CB 1 XF B	OK	46 degrees C / 114 degrees F
FPC 0 Intake	OK	30 degrees C / 86 degrees F
FPC 0 Exhaust A	OK	36 degrees C / 96 degrees F
FPC 0 Exhaust B	OK	34 degrees C / 93 degrees F
FPC 0 LU 0 TCAM TSen	OK	40 degrees C / 104 degrees F
FPC 0 LU 0 TCAM Chip	OK	42 degrees C / 107 degrees F
FPC 0 LU 0 TSen	OK	40 degrees C / 104 degrees F
FPC 0 LU 0 Chip	OK	52 degrees C / 125 degrees F
FPC 0 MQ 0 TSen	OK	40 degrees C / 104 degrees F
FPC 0 MQ 0 Chip	OK	49 degrees C / 120 degrees F
FPC 1 Intake	OK	30 degrees C / 86 degrees F
FPC 1 Exhaust A	OK	35 degrees C / 95 degrees F
FPC 1 Exhaust B	OK	34 degrees C / 93 degrees F
FPC 1 LU 0 TCAM TSen	OK	40 degrees C / 104 degrees F
FPC 1 LU 0 TCAM Chip	OK	41 degrees C / 105 degrees F
FPC 1 LU 0 TSen	OK	40 degrees C / 104 degrees F
FPC 1 LU 0 Chip	OK	51 degrees C / 123 degrees F
FPC 1 MQ 0 TSen	OK	40 degrees C / 104 degrees F
FPC 1 MQ 0 Chip	OK	46 degrees C / 114 degrees F
FPC 2 Intake	OK	30 degrees C / 86 degrees F
FPC 2 Exhaust A	OK	35 degrees C / 95 degrees F
FPC 2 Exhaust B	OK	34 degrees C / 93 degrees F
FPC 2 LU 0 TCAM TSen	OK	40 degrees C / 104 degrees F
FPC 2 LU 0 TCAM Chip	OK	40 degrees C / 104 degrees F
FPC 2 LU 0 TSen	OK	40 degrees C / 104 degrees F
FPC 2 LU 0 Chip	OK	52 degrees C / 125 degrees F
FPC 2 MQ 0 TSen	OK	40 degrees C / 104 degrees F
FPC 2 MQ 0 Chip	OK	45 degrees C / 113 degrees F
FPC 3 Intake	OK	30 degrees C / 86 degrees F
FPC 3 Exhaust A	OK	34 degrees C / 93 degrees F
FPC 3 Exhaust B	OK	33 degrees C / 91 degrees F
FPC 3 LU 0 TCAM TSen	OK	39 degrees C / 102 degrees F
FPC 3 LU 0 TCAM Chip	OK	41 degrees C / 105 degrees F
FPC 3 LU 0 TSen	OK	39 degrees C / 102 degrees F
FPC 3 LU 0 Chip	OK	48 degrees C / 118 degrees F
FPC 3 MQ 0 TSen	OK	39 degrees C / 102 degrees F
FPC 3 MQ 0 Chip	OK	46 degrees C / 114 degrees F
FPC 4 Intake	OK	30 degrees C / 86 degrees F
FPC 4 Exhaust A	OK	36 degrees C / 96 degrees F

	FPC 4 Exhaust B	OK	34 degrees C / 93 degrees F
	FPC 4 LU 0 TCAM TSen	OK	40 degrees C / 104 degrees F
	FPC 4 LU 0 TCAM Chip	OK	42 degrees C / 107 degrees F
	FPC 4 LU 0 TSen	OK	40 degrees C / 104 degrees F
	FPC 4 LU 0 Chip	OK	51 degrees C / 123 degrees F
	FPC 4 MQ 0 TSen	OK	40 degrees C / 104 degrees F
	FPC 4 MQ 0 Chip	OK	46 degrees C / 114 degrees F
	FPC 5 Intake	OK	31 degrees C / 87 degrees F
	FPC 5 Exhaust A	OK	35 degrees C / 95 degrees F
	FPC 5 Exhaust B	OK	34 degrees C / 93 degrees F
	FPC 5 LU 0 TCAM TSen	OK	41 degrees C / 105 degrees F
	FPC 5 LU 0 TCAM Chip	OK	42 degrees C / 107 degrees F
	FPC 5 LU 0 TSen	OK	41 degrees C / 105 degrees F
	FPC 5 LU 0 Chip	OK	54 degrees C / 129 degrees F
	FPC 5 MQ 0 TSen	OK	41 degrees C / 105 degrees F
	FPC 5 MQ 0 Chip	OK	44 degrees C / 111 degrees F
Fans	Top Rear Fan	OK	Spinning at normal speed
	Bottom Rear Fan	OK	Spinning at normal speed
	Top Middle Fan	OK	Spinning at normal speed
	Bottom Middle Fan	OK	Spinning at normal speed
	Top Front Fan	OK	Spinning at normal speed
	Bottom Front Fan	OK	Spinning at normal speed

The output is of an EX9208 switch. The output is similar for all EX9200 switches.

SEE ALSO

Routine Maintenance Procedures for EX9200 Switches

Installing a Fan Tray in an EX9200 Switch

Maintaining the Air Filter in EX9200 Switches

IN THIS SECTION

● Purpose | 220

● Action | 220

Purpose

For optimum cooling, verify the condition of the air filters.

Action

- Regularly inspect the air filter. A dirty air filter restricts airflow in the unit, producing a negative effect on the ventilation of the chassis. The filter degrades over time. You must replace the filter every six months.



CAUTION: Always keep the air filter in place while the switch is operating. Because the fans are very powerful, they could pull small bits of wire or other materials into the switch through the unfiltered air intake. This could damage the switch components.

- EX9200 switches ship with one air filter preinstalled. Spare air filters are separately orderable. The shelf life of the air filters vary from two to five years depending on the storage conditions. Store spare air filters in a dark, cool, and dry place. Wrap the air filters separately using plastic wraps and store them in an environment with RH between 40% to 80% and temperature between 40° F to 90° F. Storing air filters at higher temperatures or where they can be exposed to ultraviolet (UV) radiation, hydrocarbon emissions, or vapors from solvents can significantly reduce their life. If an air filter develops flakes or becomes brittle when rubbed or deformed, you must not use it.

Maintaining the EX9208 Power System

IN THIS SECTION

- [Removing an AC Power Supply from an EX9208 Switch | 221](#)
- [Installing an AC Power Supply in an EX9208 Switch | 222](#)
- [Removing a DC Power Supply from an EX9208 Switch | 224](#)
- [Installing a DC Power Supply in an EX9208 Switch | 226](#)
- [Maintaining Power Supplies in EX9200 Switches | 228](#)

Removing an AC Power Supply from an EX9208 Switch

Before you remove an AC power supply from the switch:

- Ensure you understand how to prevent electrostatic discharge (ESD) damage. See *Prevention of Electrostatic Discharge Damage*.

Ensure that you have the following parts and tools available to remove an AC power supply from an EX9208 switch chassis:

- ESD grounding strap
- Phillips (+) screwdriver, number 1 and 2
- Replacement power supply or a cover panel for the power supply slot

The AC power supply in an EX9208 switch is a hot-removable and hot-insertable field-replaceable unit (FRU). You remove AC power supplies from the front of the chassis.



CAUTION: Before you remove a power supply, ensure that you have power supplies sufficient to power the switch that remains in the chassis. See *Power Requirements for EX9200 Switch Components*.



CAUTION: Do not leave the power supply slot empty for a long time while the switch is operational. Either replace the power supply unit promptly or install a cover panel over the empty slot.

NOTE: After powering off a power supply, wait for at least 60 seconds before turning it back on.



CAUTION: Do not leave the power supply slot empty for a long time while the switch is operational. Either replace the power supply promptly or install a cover panel over the empty slot.

To remove an AC power supply from an EX9208 switch (see [Figure 74 on page 222](#)):

1. Switch off the dedicated customer site circuit breaker for the power supply, and remove the power cord from the AC power source. Follow the instructions for your site.
2. Attach the ESD grounding strap to your bare wrist, and connect the strap to the ESD point on the chassis.
3. Move the AC input switch next to the appliance inlet on the power supply to the Off (O) position.

4. Remove the power cord from the power supply.
5. Remove the power cord from the AC appliance inlet on the AC power supply faceplate.
6. Unscrew the captive screws on the bottom edge of the power supply.
7. Pull the power supply straight out of the chassis.

Figure 74: Removing an AC Power Supply from an EX9208 Switch

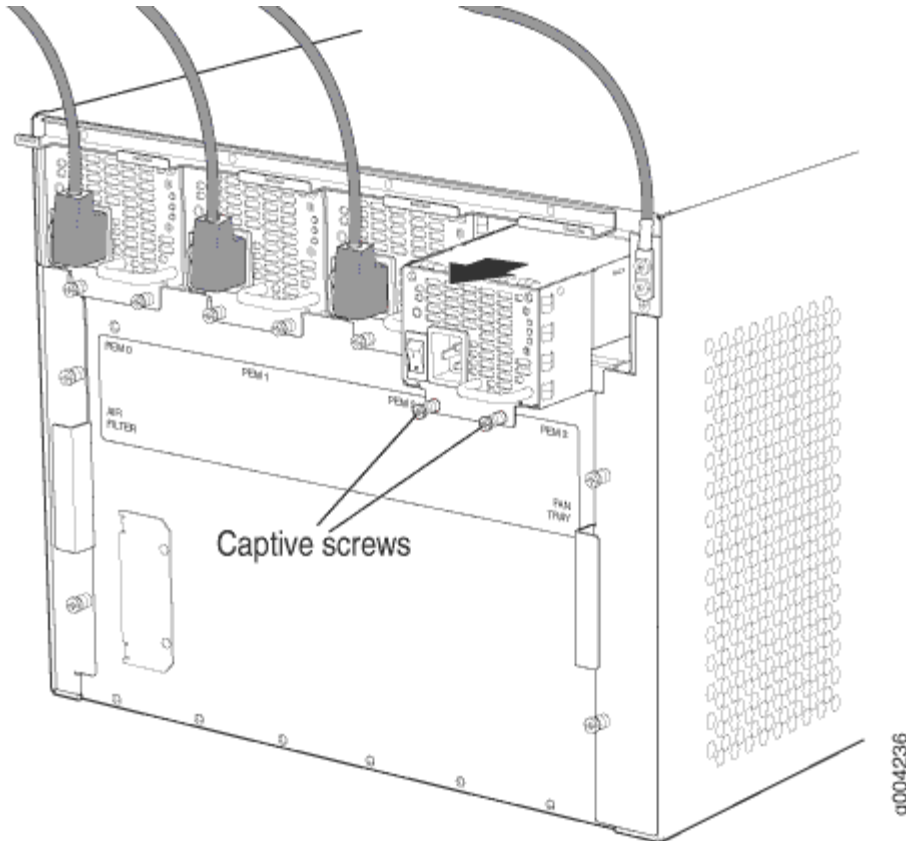

Installing an AC Power Supply in an EX9208 Switch

Before you install an AC power supply in the switch:

- Ensure you understand how to prevent electrostatic discharge (ESD) damage. See *Prevention of Electrostatic Discharge Damage*.

Ensure that you have the following parts and tools available to install an AC power supply in an EX9208 switch chassis:

- ESD grounding strap

- Phillips (+) screwdriver, number 1 and 2

The AC power supply in an EX9208 switch is a hot-insertable and hot-removable field-replaceable unit (FRU). Up to four AC power supplies can be installed in an EX9208 switch. All AC power supplies install in the rear of the chassis in the slots provided at the bottom.

NOTE: Each AC power supply must be connected to a dedicated AC power source outlet.

To install an AC power supply in an EX9208 switch (see [Figure 75 on page 224](#)):

1. Attach the ESD grounding strap to your bare wrist, and connect the strap to the ESD point on the chassis.
2. If the power supply slot has a cover panel on it, unscrew the screw on the side of the cover panel in the counterclockwise direction using the screwdriver, and remove the cover panel. Save the cover panel for later use.
3. Taking care not to touch power supply components, pins, leads, or solder connections, remove the power supply from its bag.
4. Flip the AC input switch next to the appliance inlet on the power supply to the off (O) position.
5. Using both hands, place the power supply in the power supply slot on the rear of the switch. Slide the power supply straight into the chassis until the power supply is fully seated in the slot. Ensure the power supply faceplate is flush with any adjacent power supply faceplates or power supply cover panels.
6. Push the handle toward the faceplate of the power supply until it is flush against the faceplate.
7. Push the captive screw into the power supply faceplate. Ensure that the screw is seated inside the corresponding hole on the faceplate.
8. Tighten the captive screw by turning it clockwise using the screwdriver. When the screw is completely tight, the latch locks into the switch chassis.

Figure 75: Installing an AC Power Supply in an EX9208 Switch

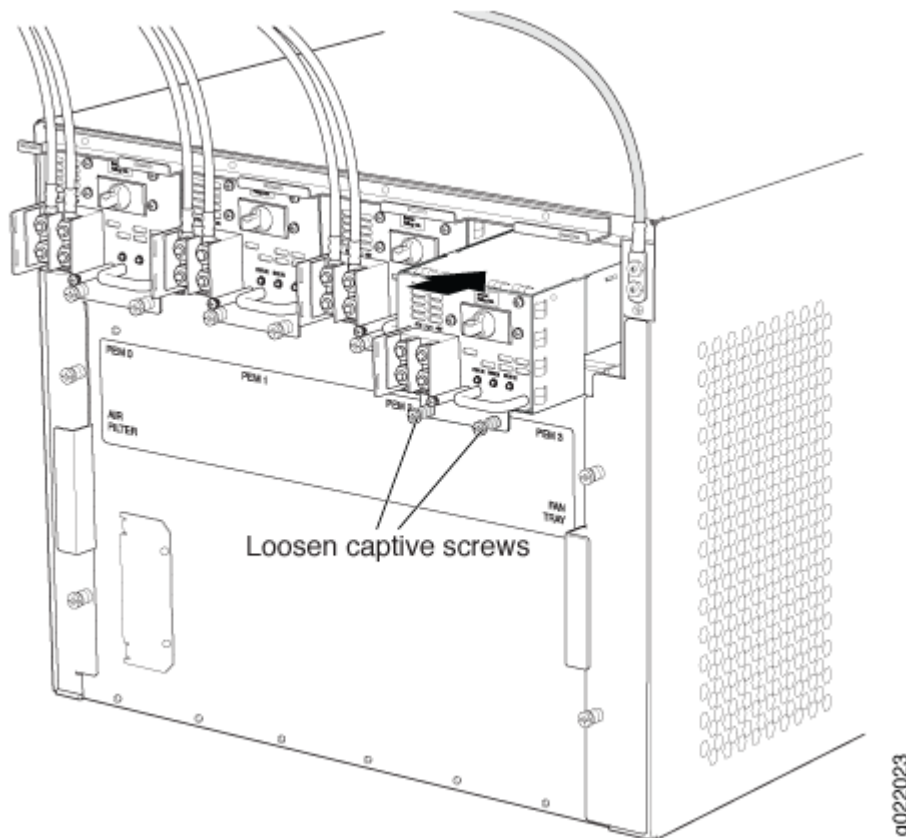

NOTE: If you have a Juniper J-Care service contract, register any addition, change, or upgrade of hardware components at <https://www.juniper.net/customers/support/tools/updateinstallbase/>. Failure to do so can result in significant delays if you need replacement parts. This note does not apply if you replace existing components with the same type of component.

To connect power to an AC power supply, see "[Connecting AC Power to an EX9208 Switch](#)" on page 184.

Removing a DC Power Supply from an EX9208 Switch

Before you remove a DC power supply from the switch:

- Ensure that you understand how to prevent electrostatic discharge (ESD) damage. See *Prevention of Electrostatic Discharge Damage*.

Ensure that you have the following parts and tools available to remove a DC power supply from an EX9208 switch chassis:

- ESD grounding strap
- Phillips (+) screwdriver, number 1 and 2
- 3/8 in. (9.5 mm) nut driver or socket wrench
- Replacement power supply or cover panel for the power supply slot

The DC power supply in an EX9208 switch is a hot-removable and hot-insertable field-replaceable unit (FRU). You remove DC power supplies from the front of the chassis.



CAUTION: Before you remove a power supply, ensure that you have power supplies sufficient to power the switch that remains in the chassis. See *Power Requirements for EX9200 Switch Components*.



CAUTION: Do not leave the power supply slot empty for a long time while the switch is operational. Either replace the power supply unit promptly or install a cover panel over the empty slot.



WARNING: Before you perform DC power procedures, ensure there is no power to the DC circuit. To ensure that all power is off, locate the circuit breaker on the panel board that services the DC circuit, switch the circuit breaker to the off position, and tape the switch handle of the circuit breaker in the off position.

NOTE: After powering off a power supply, wait for at least 60 seconds before turning it back on.

To remove a DC power supply from an EX9208 switch (see [Figure 76 on page 226](#)):

1. Switch off the dedicated customer site circuit breaker for the power supply being removed. Follow your site's procedures for ESD.
2. Make sure that the voltage across the DC power source cable leads is 0 V and that there is no chance that the cables might become active during the removal process.
3. Attach the ESD grounding strap to your bare wrist, and connect the strap to the ESD point on the chassis.
4. Move the DC circuit breaker on the DC power supply faceplate to the off (O) position
5. Remove the clear plastic cover protecting the terminal studs on the faceplate.

6. Remove the nut and washer from each of the terminal studs. (Use a 7/16-in. [11-mm] nut driver or socket wrench.)
7. Remove the cable lugs from the terminal studs.
8. Loosen the captive screws on the bottom edge of the power supply faceplate using a screwdriver.
9. Carefully move the power cables out of the way.
10. Pull the power supply straight out of the chassis.

Figure 76: Removing a DC Power Supply from an EX9208 Switch

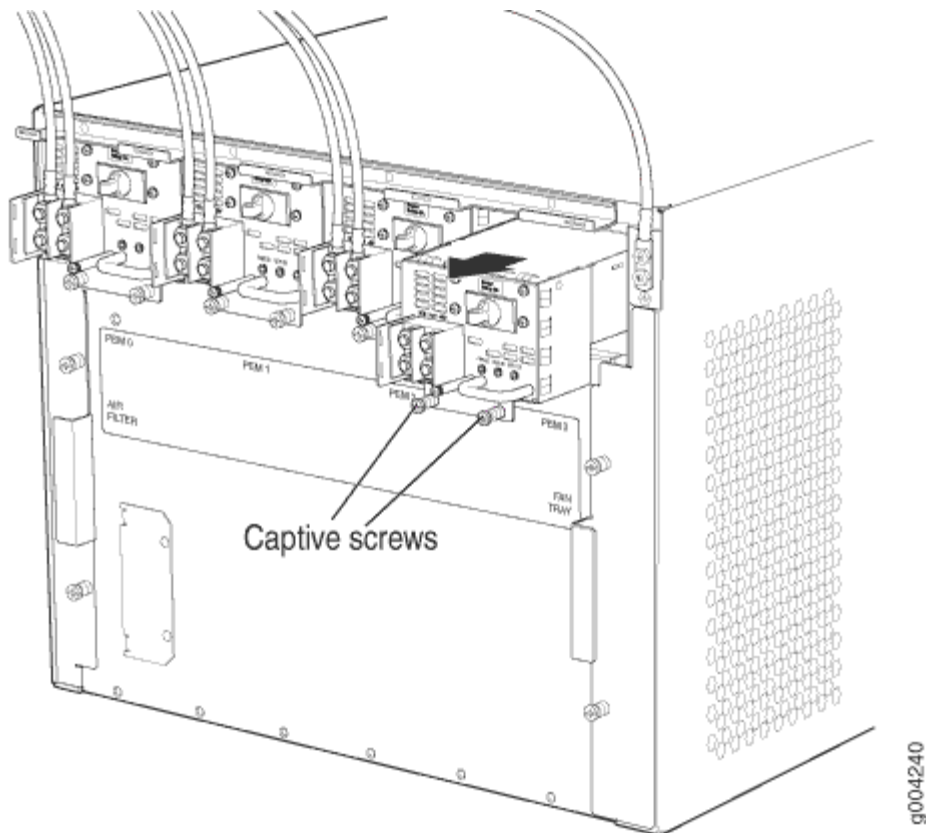

Installing a DC Power Supply in an EX9208 Switch

Before you install a DC power supply in the switch:

- Ensure you understand how to prevent electrostatic discharge (ESD) damage. See *Prevention of Electrostatic Discharge Damage*.

- Ensure that the voltage across the DC power source cable leads is 0 V and that there is no chance that the cable leads might become active during installation.

Ensure that you have the following parts and tools available to install a DC power supply in an EX9208 switch chassis:

- ESD grounding strap
- Phillips (+) screwdriver, number 1 and 2

The DC power supply in an EX9208 switch is a hot-removable and hot-insertable field-replaceable unit (FRU). Up to four DC power supplies can be installed in an EX9208 switch. All DC power supplies install in the rear of the chassis in the slots provided at the bottom.

To install a DC power supply in an EX9208 switch (see [Figure 77 on page 228](#)):

1. Attach the ESD grounding strap to your bare wrist, and connect the strap to the ESD point on the chassis.
2. If the power supply slot has a cover panel on it, unscrew the screw on the side of the cover panel in the counterclockwise direction using the screwdriver, and remove the cover panel. Save the cover panel for later use.
3. Taking care not to touch power supply components, pins, leads, or solder connections, remove the power supply from its bag.
4. Move the DC circuit breaker on the power supply faceplate to the off (O) position.
5. Using both hands, place the power supply in the power supply slot on the front of the switch. Slide the power supply straight into the chassis until the power supply is fully seated in the slot. Ensure the power supply faceplate is flush with any adjacent power supply faceplates or power supply cover panels.
6. Push the handle toward the faceplate of the power supply until it is flush against the faceplate.
7. Push the captive screw into the power supply faceplate. Ensure that the screw is seated inside the corresponding hole on the faceplate.
8. Tighten the captive screw by turning it clockwise using the screwdriver. When the screw is completely tight, the latch locks into the switch chassis.

Figure 77: Installing a DC Power Supply in an EX9208 Switch

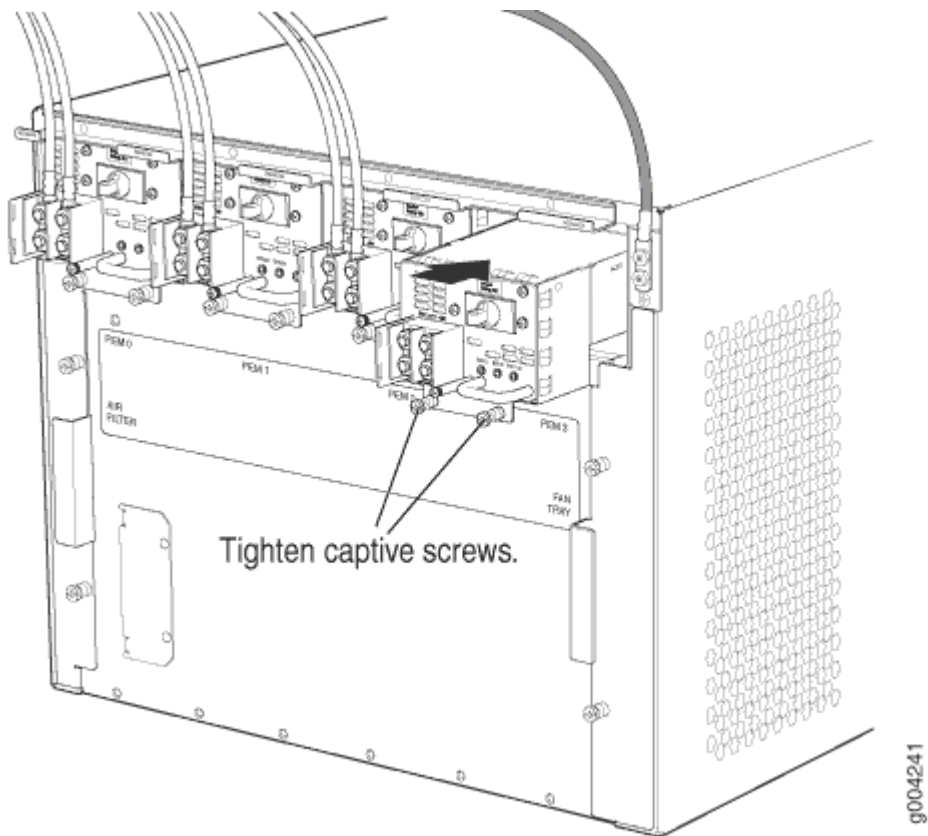

NOTE: If you have a Juniper J-Care service contract, register any addition, change, or upgrade of hardware components at <https://www.juniper.net/customers/support/tools/updateinstallbase/>. Failure to do so can result in significant delays if you need replacement parts. This note does not apply if you replace existing components with the same type of component.

To connect power to a DC power supply, see "[Connecting DC Power to an EX9208 Switch](#)" on page 187.

Maintaining Power Supplies in EX9200 Switches

IN THIS SECTION

- [Purpose](#) | 229

Purpose

For optimum switch performance, verify the condition of the installed power supplies.

Action

On a regular basis:

- Check the status of the power supplies by issuing the `show chassis environment pem` command. The output for EX9200 switches is similar to the following:

```
user@switch> show chassis environment pem
PEM 0 status:
  State           Online
  Temperature      OK
  DC Output
    Voltage(V)    Current(A)    Power(W)    Load(%)
    48            12            576         36
PEM 1 status:
  State           Online
  Temperature      OK
  DC Output
    Voltage(V)    Current(A)    Power(W)    Load(%)
    50            12            600         37
```

- Make sure that the power and grounding cables are arranged so that they do not obstruct access to other switch components.
- Routinely check the status LEDs on the power supply faceplates and the craft interface in EX9200 switches to determine whether the power supplies are functioning normally.
- Check the alarm LEDs on the craft interface in EX9200 switches. Power supply failure or removal triggers an alarm that causes one or both of the LEDs to light. You can display the associated error messages by issuing the following command:

```
user@switch> show chassis alarms
```

- Periodically inspect the site to ensure that the grounding and power cables connected to the switch are securely in place and that there is no moisture accumulating near the switch.

Maintaining the EX9200 Host Subsystem

IN THIS SECTION

- [Taking the Host Subsystem Offline in an EX9200 Switch | 230](#)
- [Removing an RE Module from an EX9200 Switch | 231](#)
- [Installing an RE Module in an EX9200 Switch | 233](#)
- [Upgrading an EX9200-SF to an EX9200-SF2 | 235](#)
- [Upgrading to an EX9200-SF3 | 238](#)
- [Removing an SF Module from an EX9200 Switch | 242](#)
- [Installing an SF Module in an EX9200 Switch | 243](#)
- [Maintaining the Host Subsystem in EX9200 Switches | 247](#)

Taking the Host Subsystem Offline in an EX9200 Switch

Before removing a Routing Engine module (RE module) from an EX9200 switch, take the host subsystem offline.

The host subsystem performs switching and system management functions in an EX9200 switch.

To take a host subsystem offline:

1. Determine whether the host subsystem is the primary or backup using one of these methods:
 - Look at the **MASTER** LED on the RE module faceplate. If the **MASTER** LED is lit steady green, the corresponding host subsystem is functioning as the primary.
 - Issue the `show chassis routing-engine` CLI command. The output of this command will show whether the host subsystem is functioning as the primary or backup.
2. If the host subsystem is functioning as the primary, switch it to backup using the `request chassis routing-engine master switch` command.

3. On the console or other management device connected to the primary Routing Engine, enter CLI operational mode and issue the `request system halt` command. The command shuts down the Routing Engine gracefully, so its state information is preserved.

Wait until a message appears on the console confirming that the operating system has halted.

NOTE: The Switch Fabric module (SF module) might continue forwarding traffic for approximately 5 minutes after the `request system halt` command has been issued.

Removing an RE Module from an EX9200 Switch

Before you begin to remove an RE module:

- Ensure you understand how to prevent electrostatic discharge (ESD) damage. See *Prevention of Electrostatic Discharge Damage*.
- Remove all the cables connected to the RE module.



CAUTION: Before you remove an RE module, you must take the host subsystem offline. If there is only one RE module installed in the switch, taking the host subsystem offline shuts down the switch.



CAUTION: If the RE module to be removed is functioning as the primary Routing Engine, switch it to be the backup Routing Engine before removing it.

Ensure that you have the following parts and tools available:

- ESD grounding strap
- Phillips (+) screwdrivers, number 1 and 2
- Antistatic bag or antistatic mat



CAUTION: Do not lift the Routing Engine module (RE module) by holding the ejector levers. The levers cannot support the weight of the module. Lifting the module by the levers might bend the levers. Bent levers will prevent the RE module from being properly seated in the chassis.

To remove an RE module from an EX9200 switch:

1. Take the host subsystem offline. See *Taking the Host Subsystem Offline in an EX9200 Switch*.
2. Place the antistatic bag or antistatic mat on a flat, stable surface.
3. Attach the ESD grounding strap to your bare wrist and connect the strap to one of the ESD points on the chassis.
4. Verify that the RE module LEDs are off.
5. Loosen the screws on each side of the RE module by turning them counterclockwise using the screwdriver until they are completely unseated.
6. Flip the ejector handles outward to unseat the RE module.
7. Grasp the RE module by the ejector handles and slide it about halfway out of the chassis.
8. Taking care not to touch the leads, pins, or solder connections, place one hand underneath the RE module to support it and slide it completely out of the chassis.
9. Place the RE module in the antistatic bag or on the antistatic mat.



CAUTION: Do not stack hardware components on one another after you remove them. Place each component on an antistatic mat resting on a stable, flat surface.

NOTE: To maintain proper airflow through the chassis, do not leave an Switch Fabric module (SF module) installed in the chassis without an RE module for extended periods of time. If you remove an RE module, install a replacement RE module as soon as possible.

Figure 78 on page 232 shows removing an RE module from an EX9204 switch. The procedure is the same for all EX9200 switches.

Figure 78: Removing an RE Module from an EX9200 Switch

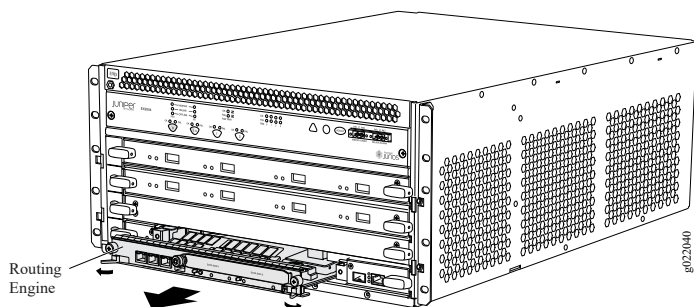

Installing an RE Module in an EX9200 Switch

Before you begin installing an RE module in an EX9200 switch:

- Ensure you understand how to prevent electrostatic discharge (ESD) damage. See *Prevention of Electrostatic Discharge Damage*.

Ensure that you have the following parts and tools available to install an RE module:

- ESD grounding strap
- Phillips (+) screwdrivers, number 1 and 2

The Routing Engine module (RE module) in an EX9200 switch is a hot-insertable and hot-removable field-replaceable unit (FRU); you can remove and replace it while the switch is running without turning off power to the switch or disrupting switching functions. Each RE module is installed horizontally in a Switch Fabric module (SF module) installed in the switch.

NOTE: In an EX9214 switch, you must install an RE module only in the SF modules installed in slots 7 and 8 labeled **0** and **1**.



CAUTION: Do not lift the RE module by holding the ejector handles. The ejector handles cannot support the weight of the module. Lifting the ejector handles by the levers might bend the levers, and the bent ejector handles will prevent the RE module from being properly seated in the chassis.

To install an RE module in an EX9200 switch:

1. Attach the ESD grounding strap to your bare wrist and connect the strap to one of the ESD points on the chassis.
2. Taking care not to touch the leads, pins, or solder connections, pull the RE module out from the bag.
3. Ensure that the ejector handles are not in the locked position. If necessary, flip the ejector handles outward.
4. Place one hand underneath the RE module to support it.
5. Carefully align the sides of the RE module with the guides inside the RE module slot on the SF.
6. Slide the RE module into the SF module until you feel resistance, and then press in the faceplate of the RE module until it engages the connectors.
7. Press both of the ejector handles inward to seat the RE module.
8. Tighten the screws, one on each side of the RE module, using a screwdriver.
9. Connect the management device cables to the RE module.

The RE module might require several minutes to boot.

After the RE module boots, verify that it is installed correctly by checking the **RE0** and **RE1** LEDs on the craft interface. If the switch is operational and the Routing Engine is functioning properly, the **ONLINE** LED glows steady green. If the **FAIL** LED glows red steadily instead, remove and install the RE module again. If the **FAIL** LED still glows red steadily, the RE module is not functioning properly. Contact your customer support representative.

You can use the `show chassis routing-engine` command to check the status of Routing Engines.

Figure 79 on page 234 shows installing an RE module in an EX9204 switch. The procedure is the same for all EX9200 switches.

Figure 79: Installing an RE Module in an EX9200 Switch

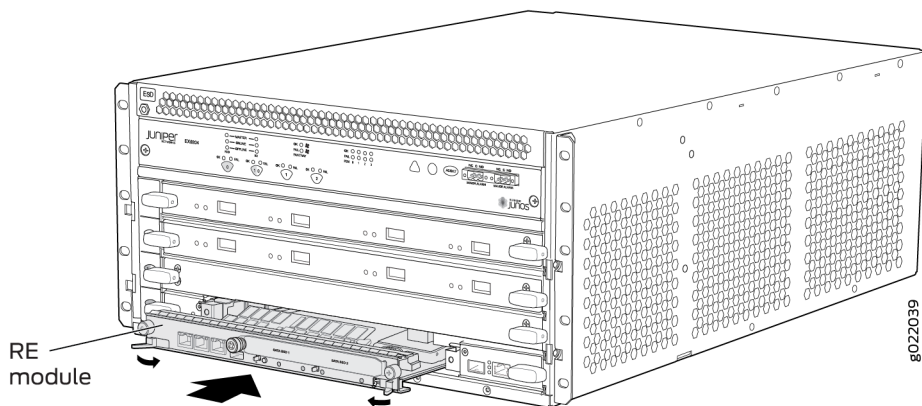

NOTE: If you have a Juniper J-Care service contract, register any addition, change, or upgrade of hardware components at <https://www.juniper.net/customers/support/tools/updateinstallbase/>. Failure to do so can result in significant delays if you need replacement parts. This note does not apply if you replace existing components with the same type of component.

SEE ALSO

Routing Engine Module in an EX9200 Switch

Upgrading an EX9200-SF to an EX9200-SF2

IN THIS SECTION

- [Preparing the EX9200 Switch for an EX9200-SF2 Upgrade | 235](#)
- [Powering Off the Switch | 236](#)
- [Removing a Routing Engine from an EX9200-SF Module | 236](#)
- [Replacing the EX9200-SF with the EX9200-SF2 | 236](#)
- [Installing a Routing Engine into an EX9200-SF2 | 236](#)
- [Powering On the Switch | 237](#)
- [Completing the EX9200-SF2 Upgrade | 237](#)

For an EX9200 switch, if you want to upgrade the original SF module, EX9200-SF, with the high-speed SF module, EX9200-SF2, follow these steps:

Preparing the EX9200 Switch for an EX9200-SF2 Upgrade

To prepare the switch for the upgrade:

1. Verify that the system runs Junos OS Release 14.1 or later by issuing the **show version** command on the switch.

```
user@switch> show version
Model: ex9208
Junos Base OS Software Suite [14.1-yyyymmdd];
...
```

NOTE: The EX9200-SF2 is supported only on Junos OS Release 14.1 or later.

The latest software ensures a healthy system—that is, a system that comprises Routing Engines, control boards, and FPCs—before the upgrade.

2. If the system is *NOT* running Junos OS Release 14.1 or later, upgrade the software now. For information about how to verify and upgrade Junos OS, see the *Junos OS Installation and Upgrade Guide*.

Powering Off the Switch

You must power off the switch before you install EX9200-SF2. See *Powering Off an EX9200 Switch*.

Removing a Routing Engine from an EX9200-SF Module

To remove a Routing Engine from the EX9200-SF:

1. Remove the cables connected to the Routing Engine.
2. Place an electrostatic bag or antistatic mat on a flat, stable surface.
3. Attach an electrostatic discharge (ESD) grounding strap to your bare wrist, and connect the strap to one of the ESD points on the chassis.
4. Loosen the captive screws on the top and bottom of the Routing Engine.
5. Flip the ejector handles outward to unseat the Routing Engine.
6. Grasp the Routing Engine by the ejector handles, and slide it about halfway out of the chassis.
7. Place one hand underneath the Routing Engine to support it, and slide it completely out of the chassis.
8. Place the Routing Engine on the antistatic mat.

Replacing the EX9200-SF with the EX9200-SF2

To replace the existing EX9200-SF with the EX9200-SF2:

1. Attach an electrostatic discharge (ESD) grounding strap to your bare wrist and connect the strap to one of the ESD points on the chassis.
2. Remove and replace the offline EX9200-SF with the EX9200-SF2.

Installing a Routing Engine into an EX9200-SF2

To install a Routing Engine into an EX9200-SF2:

1. Attach an electrostatic discharge (ESD) grounding strap to your bare wrist, and connect the strap to one of the ESD points on the chassis.
2. Ensure that the ejector handles are not in the locked position. If necessary, flip the ejector handles outward.
3. Place one hand underneath the Routing Engine to support it.
4. Carefully align the sides of the Routing Engine with the guides inside the opening on the SF2.
5. Slide the Routing Engine into the EX9200-SF2 until you feel resistance, and then press the faceplate of the Routing Engine until it engages the connectors.
6. Press both of the ejector handles inward to seat the Routing Engine.
7. Tighten the captive screws on the top and bottom of the Routing Engine.
8. Connect the management device cables to the Routing Engine.

Powering On the Switch

See *Powering On an AC-Powered EX9200 Switch* or *Powering On a DC-Powered EX9200 Switch*.

Completing the EX9200-SF2 Upgrade

To complete the upgrade procedure:

1. Verify that the installation is successful and the EX9200-SF2 is online by issuing the `show chassis environment cb` command:

```
user@switch> show chassis environment cb 0
CB 0 status
State      Online
Temperature 30 degrees C / 86 degrees F
...
user@switch> show chassis environment cb 1
CB 1 status
State      Online
Temperature 30 degrees C / 86 degrees F
...
```

Other details, such as, temperature, power, etc are also displayed along with the state.

2. Verify that the fabric planes come online correctly by issuing the `show chassis fabric summary` command:

```
user@switch> show chassis fabric summary
Plane  State  Uptime
0      Online 2 days, 19 hours, 10 minutes, 9 seconds
1      Online 2 days, 19 hours, 10 minutes, 9 seconds
...
```

3. Verify that the backup Routing Engine is back online by issuing the `show chassis routing-engine 1` command:

```
user@switch> show chassis routing-engine 1
Routing Engine Status:
Slot 1:
Current State      Backup
...
```

4. Verify that the EX9200-SF2s appear in output from the `show chassis hardware` command:

```

user@switch> show chassis hardware
Hardware inventory:
Item          Version  Part number  Serial number  Description
Chassis                               JN1221A03RFC  EX9204
Midplane      REV 01   750-053633  ACRA1451      EX9204-BP
FPM Board     REV 04   760-021392  ABCB4822      Front Panel Display
PEM 0         Rev 10   740-029970  QCS1251U020   PS 1.4-2.52kW; 90-264V AC in
PEM 1         Rev 10   740-029970  QCS1251U028   PS 1.4-2.52kW; 90-264V AC in
Routing Engine 0 REV 02   740-049603  9009153805    RE-S-EX9200-1800X4
Routing Engine 1 REV 02   740-049603  9009153993    RE-S-EX9200-1800X4
CB 0          REV 08   750-048307  CABC6474      EX9200-SF2
CB 1          REV 10   750-048307  CABH8948      EX9200-SF2
...

```

Upgrading to an EX9200-SF3

IN THIS SECTION

- [Preparing the EX9200 Switch for an EX9200-SF3 Upgrade | 239](#)
- [Powering Off the Switch | 239](#)
- [Removing a Routing Engine from an SF Module | 239](#)
- [Replacing the EX9200-SF or EX9200-SF2 with the EX9200-SF3 | 240](#)
- [Installing a Routing Engine into an EX9200-SF3 | 240](#)
- [Powering On the Switch | 240](#)
- [Completing the EX9200-SF3 Upgrade | 240](#)

If you are upgrading to the EX9200-SF3 from an older SF module, the Routing Engine must be upgraded to the first supported Junos release for the EX9200-SF3 (20.3.R1) before you install it in the EX9200-SF3. Also, we recommend that you update the recovery snapshot with the 20.3R1 or later image before you begin the upgrade. If the Routing Engine fails to boot from the primary image, it will attempt to boot from the recovery image. Since the older recovery image does not support the EX9200-SF3, the Routing Engine will crash if it attempts to boot from the old recovery image.



CAUTION: If you plug the Routing Engine into the EX9200-SF3 without first upgrading Junos to 20.3R1 or later, Junos might crash and go to a db prompt. Should this occur, you'll need to recover the router by copying the Junos software image for the 20.3R1 or later release and then booting from the USB drive to install 20.3R1 Junos on the EX9200-SF3. The USB install will wipe out the router configuration and all user files on the Routing Engine.

Preparing the EX9200 Switch for an EX9200-SF3 Upgrade

To prepare the switch for the upgrade:

1. Verify that the system runs Junos OS Release 20.3R1 or later by issuing the **show version** command on the switch.

```
user@switch> show version
Model: ex9208
Junos Base OS Software Suite [20.3-yyyymmdd];
...
```

2. If the system is *NOT* running Junos OS Release 20.3R1 or later, upgrade the software now. For information about how to verify and upgrade Junos OS, see the *Junos OS Installation and Upgrade Guide*.

Powering Off the Switch

You must power off the switch before you install EX9200-SF3. See *Powering Off an EX9200 Switch*.

Removing a Routing Engine from an SF Module

To remove a Routing Engine from an SF Module:

1. Remove the cables connected to the Routing Engine.
2. Place an electrostatic bag or antistatic mat on a flat, stable surface.
3. Attach an electrostatic discharge (ESD) grounding strap to your bare wrist, and connect the strap to one of the ESD points on the chassis.
4. Loosen the captive screws on the top and bottom of the Routing Engine.
5. Flip the ejector handles outward to unseat the Routing Engine.
6. Grasp the Routing Engine by the ejector handles, and slide it about halfway out of the chassis.
7. Place one hand underneath the Routing Engine to support it, and slide it completely out of the chassis.
8. Place the Routing Engine on the antistatic mat.

Replacing the EX9200-SF or EX9200-SF2 with the EX9200-SF3

To replace the existing SF module with the EX9200-SF3:

1. Attach an electrostatic discharge (ESD) grounding strap to your bare wrist and connect the strap to one of the ESD points on the chassis.
2. Remove and replace the offline SF module with the EX9200-SF3.

Installing a Routing Engine into an EX9200-SF3

To install a Routing Engine into an EX9200-SF3:

1. Attach an electrostatic discharge (ESD) grounding strap to your bare wrist, and connect the strap to one of the ESD points on the chassis.
2. Ensure that the ejector handles are not in the locked position. If necessary, flip the ejector handles outward.
3. Place one hand underneath the Routing Engine to support it.
4. Carefully align the sides of the Routing Engine with the guides inside the opening on the EX9200-SF3.
5. Slide the Routing Engine into the EX9200-SF3 until you feel resistance, and then press the faceplate of the Routing Engine until it engages the connectors.
6. Press both of the ejector handles inward to seat the Routing Engine.
7. Tighten the captive screws on the top and bottom of the Routing Engine.
8. Connect the management device cables to the Routing Engine.

Powering On the Switch

See *Powering On an AC-Powered EX9200 Switch* or *Powering On a DC-Powered EX9200 Switch*.

Completing the EX9200-SF3 Upgrade

To complete the upgrade procedure:

1. Verify that the installation is successful and the EX9200-SF3 is online by issuing the `show chassis environment cb` command:

```
user@switch> show chassis environment cb 0
CB 0 status
State      Online
Temperature 30 degrees C / 86 degrees F
...
user@switch> show chassis environment cb 1
CB 1 status
```

```

State      Online
Temperature 30 degrees C / 86 degrees F
...

```

Other details, such as, temperature, power, etc are also displayed along with the state.

2. Verify that the fabric planes come online correctly by issuing the `show chassis fabric summary` command:

```

user@switch> show chassis fabric summary
Plane  State    Uptime
0      Online  2 days, 19 hours, 10 minutes, 9 seconds
1      Online  2 days, 19 hours, 10 minutes, 9 seconds
...

```

3. Verify that the backup Routing Engine is back online by issuing the `show chassis routing-engine 1` command:

```

user@switch> show chassis routing-engine 1
Routing Engine Status:
Slot 1:
Current State      Backup
...

```

4. Verify that the EX9200-SF3s appear in output from the `show chassis hardware` command:

```

user@switch> show chassis hardware
Hardware inventory:
Item          Version  Part number  Serial number  Description
Chassis                               JN1221A03RFC  EX9204
Midplane      REV 01   750-053633  ACRA1451      EX9204-BP
FPM Board     REV 04   760-021392  ABCB4822      Front Panel Display
PEM 0         Rev 10   740-029970  QCS1251U020   PS 1.4-2.52kW; 90-264V AC in
PEM 1         Rev 10   740-029970  QCS1251U028   PS 1.4-2.52kW; 90-264V AC in
Routing Engine 0 REV 02   740-049603  9009153805    RE-S-EX9200-1800X4
Routing Engine 1 REV 02   740-049603  9009153993    RE-S-EX9200-1800X4
CB 0          REV 08   750-048307  CAB6474       EX9200-SF3
CB 1          REV 10   750-048307  CABH8948      EX9200-SF3
...

```

Removing an SF Module from an EX9200 Switch

Before you begin to remove an SF module:

- Ensure you understand how to prevent electrostatic discharge (ESD) damage. See *Prevention of Electrostatic Discharge Damage*.

Ensure that you have the following parts and tools available:

- ESD grounding strap
- Antistatic bag or antistatic mat
- Replacement SF module or cover panel for the slot

You must remove the Switch Fabric module (SF module) from an EX9200 switch if you need to replace the module or if you need to remove the switch components before moving the chassis without using a mechanical lift. You can remove the SF module and the Routing Engine module (RE module) as a unit, or remove the RE module separately.

NOTE: Do not lift the SF module by holding the ejector levers. The levers cannot support the weight of the module. Lifting the modules by the levers might bend the levers. Bent levers will prevent the SF module from being properly seated in the chassis.



CAUTION: Before you replace an SF module, you must take the host subsystem offline. If there is only one host subsystem, taking the host subsystem offline shuts down the switch.

To remove an SF module:

1. Take the host subsystem offline. See *Taking the Host Subsystem Offline in an EX9200 Switch*.
2. Place the antistatic bag or antistatic mat on a flat, stable surface.
3. Attach the ESD grounding strap to your bare wrist and connect the strap to the ESD point on the chassis.
4. Rotate the ejector handles simultaneously counterclockwise to unseat the SF module.
5. Grasp the ejector handles and slide the SF module about halfway out of the chassis.
6. Place one hand underneath the SF module to support it, and slide it completely out of the chassis. Place it on the antistatic mat.



CAUTION: Do not stack hardware components on one another after you remove them. Place each component on an antistatic mat resting on a stable, flat surface.

7. If you are not replacing the SF module, install a cover panel over the empty slot.

Figure 80 on page 243 shows removing an SF module from an EX9208 switch. The procedure is the same for all EX9200 switches.

Figure 80: Removing an SF Module from an EX9200 Switch

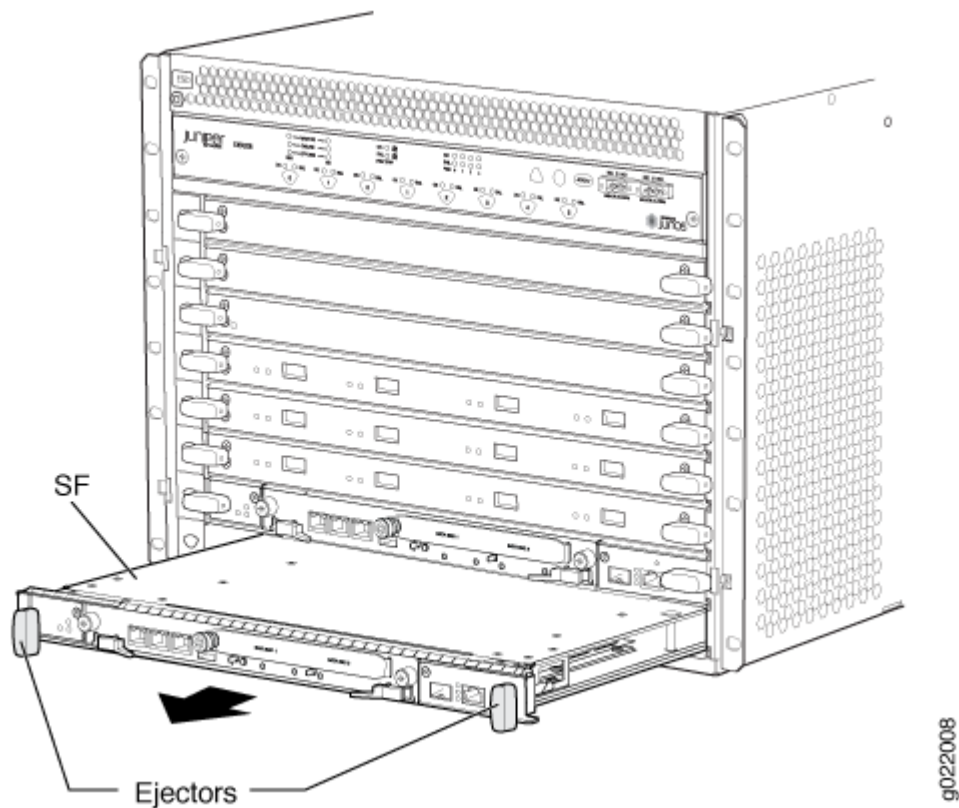

Installing an SF Module in an EX9200 Switch

Before you begin installing an SF module:

- Ensure you understand how to prevent electrostatic discharge (ESD) damage. See *Prevention of Electrostatic Discharge Damage*.

Ensure that you have the following parts and tools available:

- ESD grounding strap

The Switch Fabric module (SF module) in an EX9200 switch is a hot-insertable and hot-removable field-replaceable unit (FRU); You can remove and replace it while the switch is running without turning off power to the switch or disrupting switching functions.

NOTE: Do not lift the SF module by holding the ejector handles. The ejector handles cannot support the weight of the module. Lifting the module by the ejector handles might bend the ejector handles. Bent ejector handles prevent the SF module from being properly seated in the chassis.

To install an SF module:

1. Attach the ESD grounding strap to your bare wrist, and connect the strap to one of the ESD points on the chassis.
2. If the slot has a cover panel on it, rotate the ejector handles simultaneously counterclockwise to unseat the cover panel.
3. Grasp the ejector handles, and slide the cover panel out of the chassis. Save the cover panel for later use.
4. Taking care not to touch the leads, pins, or solder connections, pull the SF module out from the bag.
5. Rotate the ejector handles to a vertical position.
6. Align the sides of the SF module with the guides inside the chassis.
7. Ensuring that the module remains correctly aligned, slide the SF module into the chassis until you feel resistance.
8. Rotate both the ejector handles simultaneously clockwise until the SF module is fully seated. Place the ejector handles in the proper position, horizontally and toward the center of the board.
9. Verify that the SF module is installed correctly and functioning normally by checking the LEDs on the faceplate of the SF module.
 - The **OK/FAIL** LED glows steady green a few minutes after the SF module is successfully installed.
 - If the **OK/FAIL** LED is red, remove and install the SF module again. If the **OK/FAIL** LED is still red or is off, the SF module is not functioning properly. Contact your customer support representative.
10. Check the status of the SF using the `show chassis environment cb` command:

```
user@switch> show chassis environment cb
CB 0 status:
```



```

State                               Online Master
Temperature                          29 degrees C / 84 degrees F
Power 1
  1.0 V                               1002 mV
  1.2 V                               1218 mV
  1.5 V                               1472 mV
  1.8 V                               1830 mV
  2.5 V                               2526 mV
  3.3 V                               3338 mV
  5.0 V                               5059 mV
  5.0 V RE                            4969 mV
  12.0 V                              12239 mV
  12.0 V RE                           12123 mV
Power 2
  4.6 V bias MidPlane                4840 mV
  11.3 V bias PEM                    11176 mV
  11.3 V bias FPD                    11292 mV
  11.3 V bias POE 0                  11272 mV
  11.3 V bias POE 1                  11311 mV
Bus Revision                          64
FPGA Revision                         13
PMBus                                 Expected Measured Measured Calculated
device                               voltage  voltage  current  power
  XF ASIC A                          1000 mV   997 mV  13625 mA  13584 mW
  XF ASIC B                          1000 mV  1000 mV  12484 mA  12484 mW

```

CB 1 status:

```

State                               Online Standby
Temperature                          29 degrees C / 84 degrees F
Power 1
  1.0 V                               1002 mV
  1.2 V                               1214 mV
  1.5 V                               1472 mV
  1.8 V                               1807 mV
  2.5 V                               2520 mV
  3.3 V                               3319 mV
  5.0 V                               5059 mV
  5.0 V RE                            4969 mV
  12.0 V                              12258 mV
  12.0 V RE                           12239 mV
Power 2
  4.6 V bias MidPlane                4840 mV
  11.3 V bias PEM                    11195 mV
  11.3 V bias FPD                    11234 mV

```

11.3 V bias POE 0		11176 mV		
11.3 V bias POE 1		11214 mV		
Bus Revision		64		
FPGA Revision		13		
PMBus	Expected	Measured	Measured	Calculated
device	voltage	voltage	current	power
XF ASIC A	1000 mV	1002 mV	11281 mA	11303 mW
XF ASIC B	1000 mV	997 mV	11015 mA	10981 mW

NOTE: The output is of an EX9208 switch. The output is similar for all EX9200 switches.

Figure 81 on page 246 shows installing an SF module in an EX9208 switch. The procedure is the same for all EX9200 switches.

Figure 81: Installing an SF Module in an EX9200 Switch

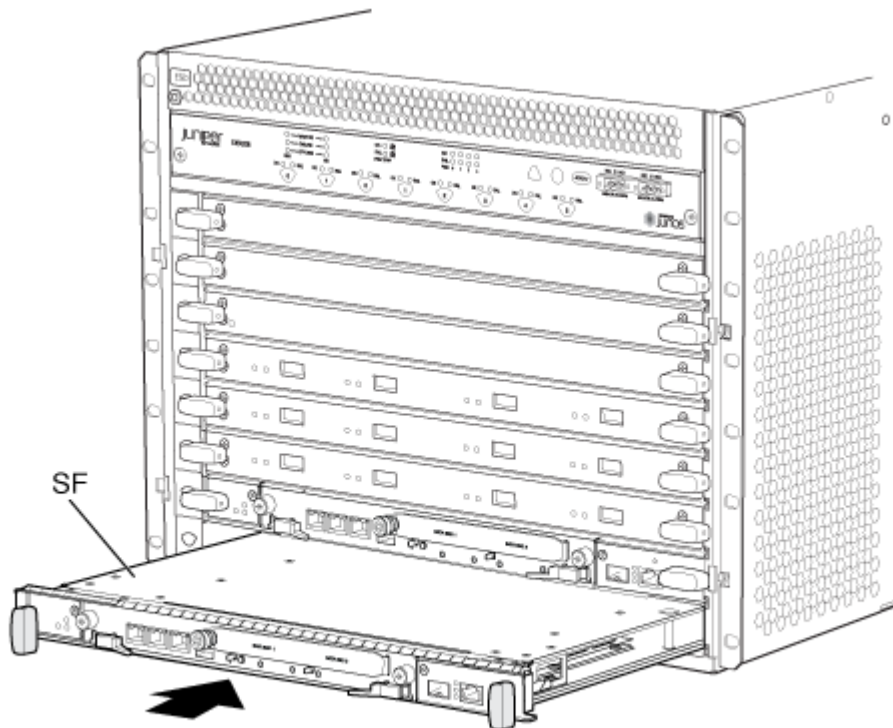

g022010

NOTE: If you have a Juniper J-Care service contract, register any addition, change, or upgrade of hardware components at <https://www.juniper.net/customers/support/tools/updateinstallbase/> . Failure to do so can result in significant delays if you need replacement parts. This note does not apply if you replace existing components with the same type of component.

SEE ALSO

| *Switch Fabric Module in an EX9200 Switch*

Maintaining the Host Subsystem in EX9200 Switches

IN THIS SECTION

- Purpose | 247
- Action | 247

Purpose

For optimum performance of an EX9200 switch, verify the condition of the host subsystem. The host subsystem comprises a Switch Fabric and a Routing Engine. Routing Engine module (RE module) is installed directly into a Switch Fabric module (SF module).

Action

On a regular basis:

- Check the LEDs on the craft interface to view information about the status of the Routing Engines.
- Check the LEDs on the SF module faceplate.
- Check the LEDs on the RE module faceplate.

- To check the status of the Routing Engines, issue the `show chassis routing-engine` command. The output is similar to the following:

```

user@switch> show chassis routing-engine
Routing Engine status:
Slot 0:
  Current state           Master
  Election priority       Master (default)
  Temperature             31 degrees C / 87 degrees F
  CPU temperature         30 degrees C / 86 degrees F
  DRAM                   3313 MB (8192 MB installed)
  Memory utilization      56 percent
  CPU utilization:
    User                  78 percent
    Background            0 percent
    Kernel                21 percent
    Interrupt             1 percent
    Idle                  0 percent
  Model                   RE-S-EX9200-1800X4
  Serial ID               9009114067
  Start time              2013-02-22 22:28:07 PST
  Uptime                  2 days, 3 hours, 38 minutes, 48 seconds
  Last reboot reason      Router rebooted after a normal shutdown.
  Load averages:         1 minute   5 minute   15 minute
                        0.79       0.49       0.42

Routing Engine status:
Slot 1:
  Current state           Backup
  Election priority       Backup (default)
  Temperature             33 degrees C / 91 degrees F
  CPU temperature         31 degrees C / 87 degrees F
  DRAM                   3313 MB (16384 MB installed)
  Memory utilization      28 percent
  CPU utilization:
    User                  6 percent
    Background            0 percent
    Kernel                6 percent
    Interrupt             1 percent
    Idle                  88 percent
  Model                   RE-S-EX9200-1800X4
  Serial ID               9009118544
  Start time              2013-02-22 22:27:58 PST

```

```

Uptime                2 days, 3 hours, 38 minutes, 44 seconds
Last reboot reason    Router rebooted after a normal shutdown.
Load averages:        1 minute   5 minute  15 minute
                       0.06      0.02    0.00

```

The output is of an EX9208 switch. The output is similar for all EX9200 switches.

- To check the status of the Switch Fabrics, issue the `show chassis environment cb` command. The output is similar to the following:

```

user@switch> show chassis environment cb
CB 0 status:
State                Online Master
Temperature          30 degrees C / 86 degrees F
Power 1
  1.0 V              1005 mV
  1.2 V              1218 mV
  1.5 V              1475 mV
  1.8 V              1830 mV
  2.5 V              2520 mV
  3.3 V              3345 mV
  5.0 V              5053 mV
  5.0 V RE           4962 mV
  12.0 V             12220 mV
  12.0 V RE          12123 mV
Power 2
  4.6 V bias MidPlane  4840 mV
  11.3 V bias PEM      11176 mV
  11.3 V bias FPD      11292 mV
  11.3 V bias POE 0    11272 mV
  11.3 V bias POE 1    11311 mV
Bus Revision         64
FPGA Revision        13
PMBus                Expected  Measured  Measured  Calculated
device               voltage   voltage   current   power
  XF ASIC A           1000 mV   998 mV   13609 mA  13581 mW
  XF ASIC B           1000 mV   1000 mV  12390 mA  12390 mW
CB 1 status:
State                Online Standby
Temperature          30 degrees C / 86 degrees F
Power 1
  1.0 V              1002 mV

```

```

1.2 V          1214 mV
1.5 V          1472 mV
1.8 V          1804 mV
2.5 V          2520 mV
3.3 V          3325 mV
5.0 V          5053 mV
5.0 V RE      4969 mV
12.0 V        12239 mV
12.0 V RE     12239 mV
Power 2
4.6 V bias MidPlane  4840 mV
11.3 V bias PEM      11176 mV
11.3 V bias FPD      11234 mV
11.3 V bias POE 0    11176 mV
11.3 V bias POE 1    11214 mV
Bus Revision         64
FPGA Revision        13
PMBus                Expected Measured Measured Calculated
device                voltage  voltage  current  power
XF ASIC A             1000 mV  1002 mV  11234 mA  11256 mW
XF ASIC B             1000 mV   998 mV  11000 mA  10978 mW

```

The output is of an EX9208 switch. The output is similar for all EX9200 switches.

To check the status of a specific Switch Fabric, issue the `show chassis environment cb` command and include the slot number of the SF. The output is similar to the following:

```

user@switch> show chassis environment cb 0
CB 0 status:
State                Online Master
Temperature           30 degrees C / 86 degrees F
Power 1
1.0 V                1002 mV
1.2 V                1218 mV
1.5 V                1475 mV
1.8 V                1827 mV
2.5 V                2526 mV
3.3 V                3338 mV
5.0 V                5053 mV
5.0 V RE             4969 mV
12.0 V               12220 mV
12.0 V RE            12123 mV

```

```

Power 2
 4.6 V bias MidPlane      4840 mV
11.3 V bias PEM           11176 mV
11.3 V bias FPD           11292 mV
11.3 V bias POE 0         11272 mV
11.3 V bias POE 1         11311 mV
Bus Revision               64
FPGA Revision              13
PMBus                      Expected Measured Measured Calculated
device                     voltage  voltage  current  power
XF ASIC A                   1000 mV   997 mV  13609 mA  13568 mW
XF ASIC B                   1000 mV  1000 mV  12484 mA  12484 mW

```

The output is of an EX9208 switch. The output is similar for all EX9200 switches.

For more information about using the CLI, see the Junos OS documentation.

Maintaining the EX9200 Line Cards

IN THIS SECTION

- [Handling and Storing Line Cards | 252](#)
- [Maintaining Line Card Cables | 255](#)
- [Unpacking a Line Card Used in an EX9200 Switch | 255](#)
- [Removing a Line Card from an EX9200 Switch | 256](#)
- [Installing a Line Card in an EX9200 Switch | 259](#)
- [Removing a MIC from an EX9200-MPC Line Card | 261](#)
- [Installing a MIC in an EX9200-MPC Line Card | 264](#)

Handling and Storing Line Cards

IN THIS SECTION

- [Holding a Line Card | 252](#)
- [Storing a Line Card | 254](#)

Components in the line cards are fragile. To avoid damaging the line cards, follow the procedures in this topic. The procedures use the following terms to describe the four edges of the line cards:

- Faceplate—Edge of the line card that has connectors into which you insert the transceivers.
- Connector edge—Edge opposite the faceplate.
- Top edge—Edge at the top of the line card when the line card is vertical.
- Bottom edge—Edge at the bottom of the line card when the line card is vertical.



CAUTION: Failure to handle line cards as specified in these procedures can cause irreparable damage to them.

Holding a Line Card

You must hold a line card horizontally when installing it in the chassis. You may hold a line card vertically or horizontally when carrying it.



CAUTION: Be prepared to support the full weight as you slide the line card into the chassis.

To hold a line card vertically:

1. Orient the line card so that the faceplate faces you. To verify the orientation, confirm that the text on the line card is right-side up.
2. Place one hand around the line card faceplate about a quarter of the way down from the top edge. Do not press hard on it.
3. Place the other hand at the bottom edge of the line card.

If the line card is horizontal before you grasp it, place your left hand around the faceplate and your right hand along the bottom edge.

To hold a line card horizontally:

1. Orient the line card so that the faceplate faces you.
2. Grasp the top edge with your left hand and the bottom edge with your right hand.

You can rest the faceplate of the line card against your body as you carry it.



CAUTION: Take care not to hit the line card against any object as you carry it. Line card components are fragile.

Never hold or grasp the line card anywhere except the places mentioned in these procedures. In particular, never grasp the connector edge. See Figure 1.

Figure 82: Do Not Grasp the Connector Edge

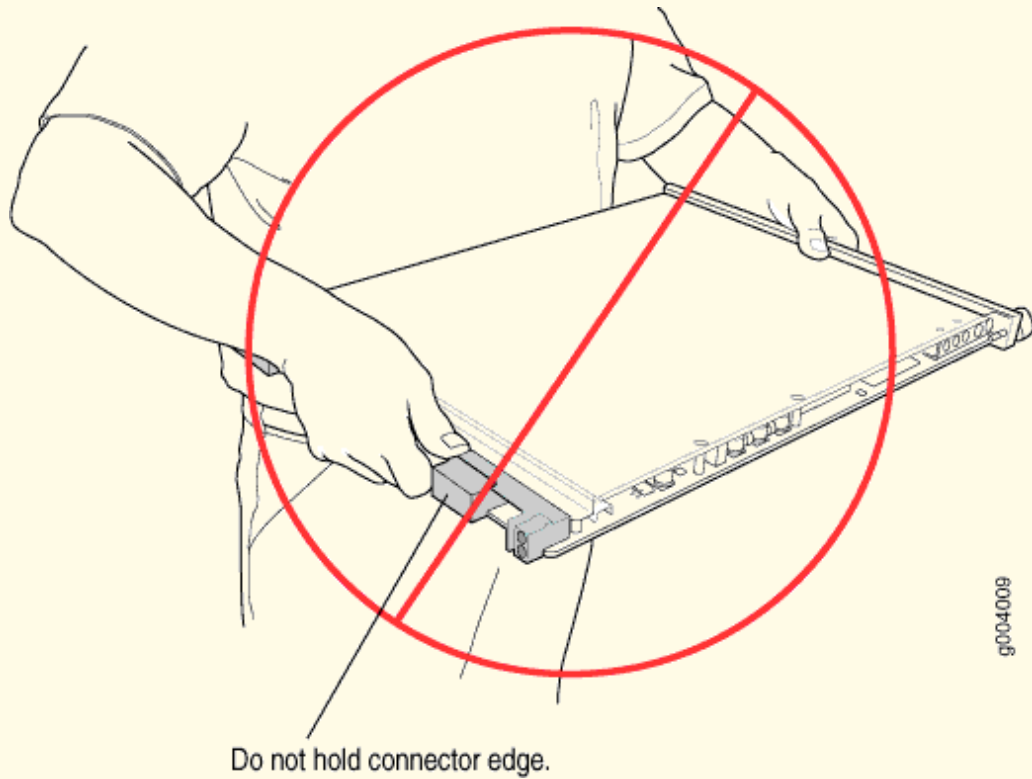

Do not hold connector edge.

Never carry the line card while holding the faceplate with only one hand.

Do not rest any edge of a line card directly against a hard surface. See Figure 2.

g004009

Figure 83: Do Not Rest the Edge of a Line Card on a Hard Surface

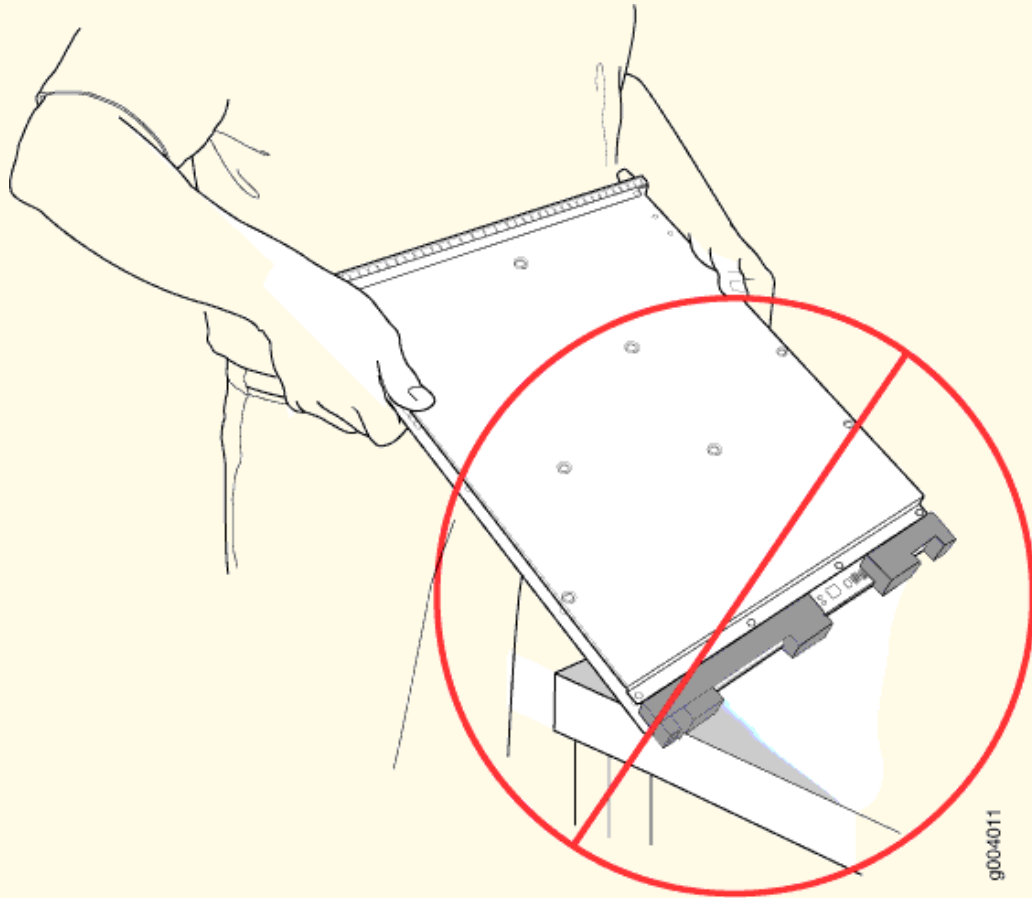

Do not rest connectors on any surface.

If you must rest a line card temporarily on an edge, place a cushion between the edge and the surface.

Do not stack line cards on top of one another or on top of any other component. Place each line card separately in an antistatic bag or on an antistatic mat placed on a flat, stable surface.

Storing a Line Card

You must store a line card in the chassis or in a spare shipping container, horizontally and sheet metal side down. Do not stack line cards on top of one another or on top of any other component. Place each line card separately in an antistatic bag or on an antistatic mat placed on a flat, stable surface.

NOTE: Because a line card is heavy, and because antistatic bags are fragile, inserting the line card into the bag is best done with two people, each to do one of the following steps.

To insert a line card into an antistatic bag:

1. Hold the line card in the horizontal position with the faceplate facing you.
2. Slide the opening of the bag over the line card connector edge.

If you must insert the line card into a bag by yourself:

1. Lay the line card horizontally on a flat, stable surface, sheet metal side down.
2. Orient the line card with the faceplate facing you.
3. Carefully insert the line card connector edge into the opening of the bag and pull the bag toward you to cover the line card.

Maintaining Line Card Cables

Components in the line cards are fragile. To extend the lives of your line card cables and to avoid problems that can result from cable damage, follow these procedures:

To maintain line card cables:

- Place excess cable out of the way. Do not allow fastened loops of cable to dangle from the connector. Placing fasteners on the loops helps retain their shape.
- Keep the cable connections clean and free of dust and other particles, which can cause drops in the received power level. Always inspect cables and clean them if necessary before connecting a port.
- Label both ends of line card cables to identify them.

Unpacking a Line Card Used in an EX9200 Switch

Before you unpack a line card:

- Ensure that you have taken the necessary precautions to prevent electrostatic discharge (ESD) damage (see *Prevention of Electrostatic Discharge Damage*).
- Ensure that you know how to handle and store the line card (see *Handling and Storing Line Cards*).

The line cards for EX9200 switches are rigid sheet-metal structures that house the line card components including network ports. The line cards are shipped in a cardboard carton, secured with foam packing material.



CAUTION: The line cards are maximally protected inside the shipping carton. Do not unpack the line cards until you are ready to install them in the switch chassis.

To unpack a line card (see [Figure 84 on page 256](#)):

1. Move the shipping carton to a staging area as close to the installation site as possible.
2. Position the carton so that the arrows are pointing up.
3. Open the top flaps on the shipping carton.
4. Pull out the packing material, which holds the line card in place.
5. Remove the line card from the antistatic bag.
6. Save the shipping carton and packing materials in case you need to move or ship the line card later.

Figure 84: Unpacking a Line Card Used in an EX9200 Switch

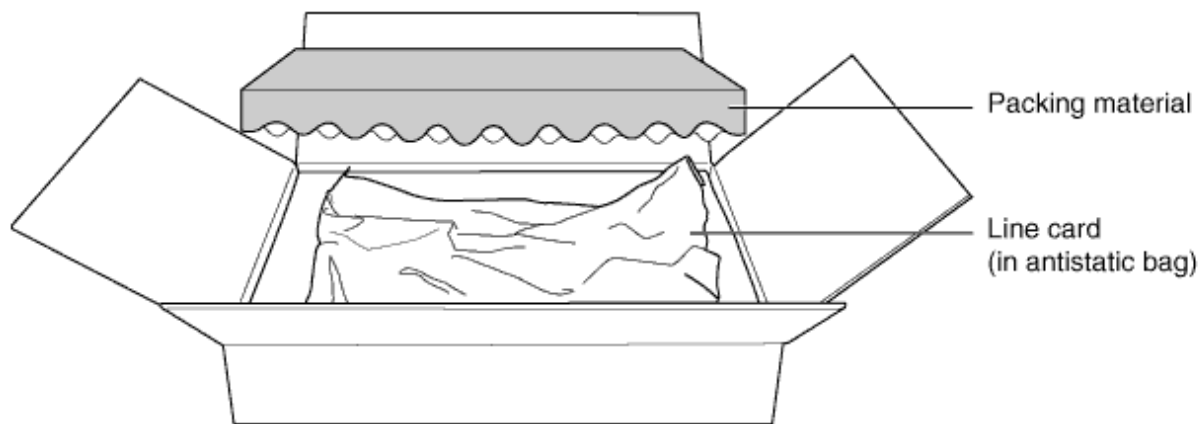

Removing a Line Card from an EX9200 Switch

Before you begin removing a line card from an EX9200 switch:

- Ensure that you have taken the necessary precautions to prevent electrostatic discharge (ESD) damage. See *Prevention of Electrostatic Discharge Damage*.
- If there are any transceivers installed in the line card, remove them before you remove the line card. See *Remove a Transceiver*.

- Ensure that you know how to handle and store the line card. See *Handling and Storing Line Cards*.

Ensure that you have the following parts and tools available to remove a line card from an EX9200 switch chassis:

- ESD grounding strap
- An antistatic bag or an antistatic mat
- Replacement line card or a cover panel and its captive screws to cover the empty slot

EX9200 switches have field-replaceable unit (FRU) line cards that can be installed in the line card slots on the front of the switch chassis. The line cards are hot-insertable and hot-removable: You can remove and replace them without powering off the switch or disrupting switch functions. However, we recommend that you take them offline before removing them.

To remove a line card from an EX9200 switch:

1. Place the antistatic bag or antistatic mat on a flat, stable surface.
2. Attach the ESD grounding strap to your bare wrist, and connect the strap to the ESD point on the switch chassis.
3. Label the cables connected to each port on the line card so you can reconnect the cables to the correct ports.
4. Take the line card offline by issuing the following CLI command:

```
user@switch> request chassis fpc slot slot-number offline
```

5. Rotate the ejector handles simultaneously counterclockwise to unseat the line card.
6. Grasp the handles, and gently slide the line card halfway out of the chassis.

See *Handling and Storing Line Cards*.



CAUTION: Do not lift the line card by holding the ejector levers on the faceplate or the edge connectors. The levers cannot support the weight of the line card. Lifting the line cards by the levers might bend them. Bent levers prevent the line cards from being properly seated in the chassis.



CAUTION: Do not stack line cards on top of one another or on top of any other component. Place each line card separately in the antistatic bag or on the antistatic mat placed on a flat, stable surface.



CAUTION: The weight of line cards in EX9200 switches is in the range 14–19.4 lb (6.6–8.8 kg). Be prepared to support the full weight as you slide the line card into the chassis.

7. Place one hand around the faceplate of the line card and the other hand under the line card to support it. Taking care not to touch line card components, pins, leads, or solder connections, gently slide the line card completely out of the chassis and place it in an antistatic bag or on its own antistatic mat placed on a flat, stable surface.



CAUTION: After removing a line card, wait for at least 30 seconds before installing a line card or removing another line card.

8. If you are not installing a line card in the emptied line card slot within a short time, install a cover panel over the slot. Do this to protect the interior of the chassis from dust or other foreign substances and to ensure that the airflow inside the chassis is not disrupted.

Figure 85 on page 258 shows removing a line card from an EX9204 switch. The procedure and orientation of the line card are the same for EX9208. The procedure is the same for EX9214 switch; however, the orientation of the line cards is different—it is installed vertically into the top and bottom of the chassis.

Figure 85: Removing a Line Card from an EX9200 Switch

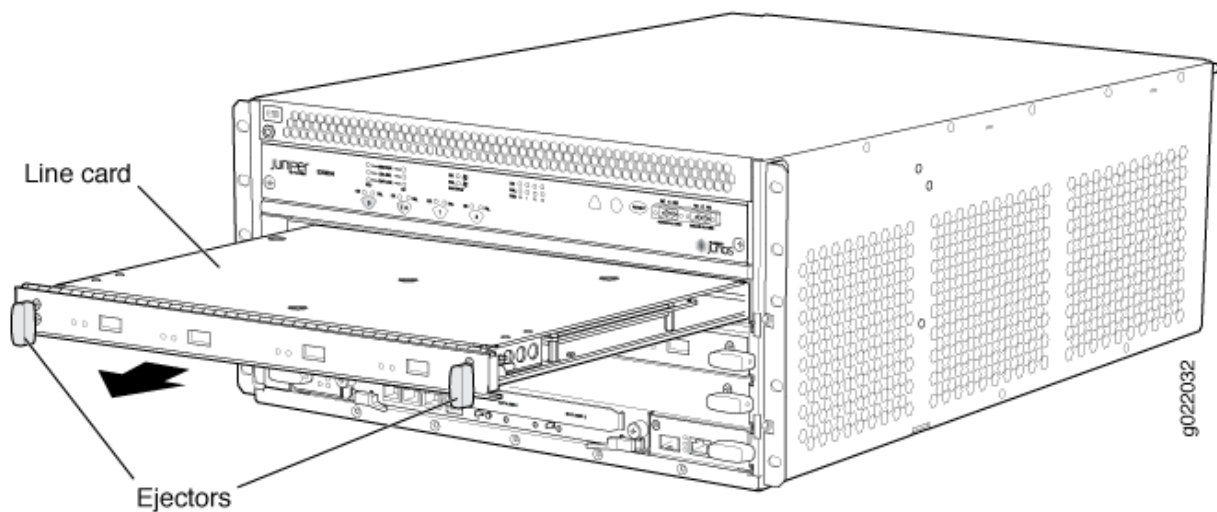

Installing a Line Card in an EX9200 Switch

Before you begin installing a line card in the switch:

- Ensure that you have taken the necessary precautions to prevent electrostatic discharge (ESD) damage (see *Prevention of Electrostatic Discharge Damage*).
- If there are any transceivers installed in the line card, remove them before you install the line card. For instructions on removing transceivers, see *Remove a Transceiver*.
- Ensure that you know how to handle and store the line card (see *Handling and Storing Line Cards*).

Ensure that you have the following parts and tools available to install a line card in the switch:

- ESD grounding strap

EX9200 switches have field-replaceable unit (FRU) line cards that can be installed in the line card slots on the front of the switch chassis. The line cards are hot-insertable and hot-removable: You can remove and replace them without powering off the switch or disrupting switch functions. However, we recommend that you take them offline before removing them.

To install a line card in the switch:

1. Attach the ESD grounding strap to your bare wrist, and connect the strap to the ESD point on the switch chassis.
2. If the slot has a cover panel on it, rotate the ejector handles simultaneously counterclockwise to unseat the cover panel.
3. Grasp the ejector handles, and slide the cover panel out of the chassis. Save the cover panel for later use.
4. Taking care not to touch line card components, pins, leads, or solder connections, remove the line card from its bag.



CAUTION: Do not lift the line card by holding the ejector handles on the faceplate or the edge connectors. The ejector handles cannot support the weight of the line card. Lifting the line card by the ejector handles might bend them. Bent ejector handles prevent line cards from being properly seated in the chassis.

5. Ensure that the ejector handles are not in the locked position. If necessary, flip the ejector handles outward.
6. Place one hand around the faceplate of the line card and the other hand under the line card to support it.



CAUTION: The weight of line cards in EX9200 switches is in the range 14–19.4 lb (6.6–8.8 kg). Be prepared to support the full weight as you slide the line card into the chassis.

Before you slide the line card into the slot on the switch chassis, ensure the line card is aligned correctly. Misalignment might cause the pins to bend, making the line card unusable.

7. Lift the line card, and position it in the chassis with the faceplate facing you and the sides of the line card aligned with the guides in the line card slot on the switch chassis.
8. Make sure the handles stay in the open position and gently slide the line card fully into the slot using both hands.
9. Rotate both of the ejector handles inward to seat the line card.
10. Bring the line card online by pressing the corresponding line card control button on the craft interface or by issuing the following CLI command:

```
user@switch> request chassis fpc slot slot-number online
```

NOTE: On EX9204, EX9208, and EX9214 switches, when a line card is brought online, if the aggregate interface is initialized before the child interface is marked as part of the aggregate interface, there might be a loss of traffic from the aggregate interface for up to 30 seconds and the CPU usage of the line card installed on the switch might go up to 100%.

[Figure 86 on page 261](#) shows installing a line card in an EX9204 switch. The procedure and orientation of the line card are the same for EX9208. The procedure is the same for EX9214 switch; however, the orientation of the line card is different—it is installed vertically in the chassis.

Figure 86: Installing a Line Card

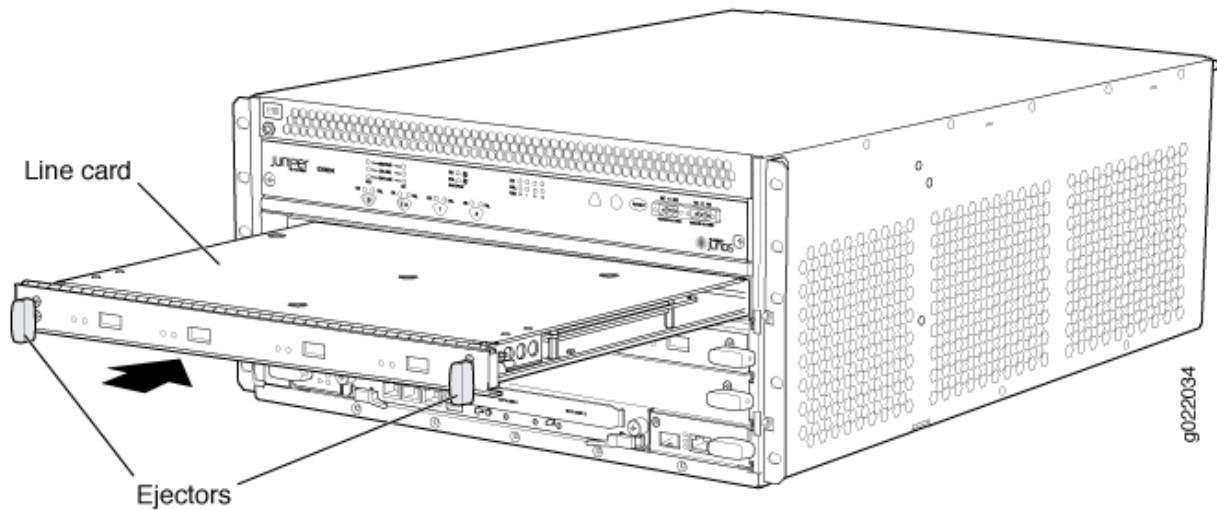

You can verify that the line card is functioning correctly by issuing the `show chassis fpc` and `show chassis fpc pic-status` commands.

NOTE: If you have a Juniper J-Care service contract, register any addition, change, or upgrade of hardware components at <https://www.juniper.net/customers/support/tools/updateinstallbase/>. Failure to do so can result in significant delays if you need replacement parts. This note does not apply if you replace existing components with the same type of component.

Removing a MIC from an EX9200-MPC Line Card

Before you begin removing a MIC from an EX9200-MPC line card:

- Ensure that you have taken the necessary precautions to prevent electrostatic discharge (ESD) damage (see *Prevention of Electrostatic Discharge Damage*).
- Ensure that you know how to handle and store the line card (see *Handling and Storing Line Cards*).

Ensure that you have the following parts and tools available:

- (If you will replace the MIC by installing only one EX9200-10XS-MIC or EX9200-20F-M-MIC) A septum if it is not installed in the line card and screws to secure the septum
- One or two MIC slot cover panels and screws for installing the MIC slot cover panels. You must install both the MIC slot cover panels if you will not install any MIC, or install one cover panel in the empty portion of the MIC slot if you will install only one EX9200-10XS-MIC or EX9200-20F-M-MIC.

- Rubber safety caps to cover transceivers
- ESD grounding strap
- Phillips (+) screwdriver, number 2

The EX9200-MPC line card has two slots on the faceplate in which you can install the supported Modular Interface Cards (MICs). The EX9200-MPC line card accepts the following MICs:

- EX9200-10XS-MIC
- EX9200-20F-MIC
- EX9200-40T-MIC

The MICs are hot-insertable and hot-removable field replaceable units (FRUs): You can remove and replace them without powering off the switch or disrupting switch functions. However, if you remove a MIC, the interface for that MIC ceases to function.



WARNING: Do not remove any MIC from the EX9200-40F line card, EX9200-40F-M line card, EX9200-40T line card, or EX9200-4QS line card.

To remove a MIC from an EX9200-MPC line card:

1. Place the antistatic bag or antistatic mat on a flat, stable surface.
2. Attach the ESD grounding strap to your bare wrist and connect the strap to the ESD point on the rear panel of the EX9200 switch.
3. Label the cables connected to the MIC so that you can reconnect them correctly.
4. If there are transceivers installed in the MIC, remove them (see *Remove a Transceiver*).
5. Take the MIC offline by pressing the power button on the MIC until the **OK/FAIL** LED on the MIC is unlit or by issuing the following CLI command:

```
user@host> request chassis mic fpc-slot slot-number mic-slot slot-number offline
```

6. If you are removing an EX9200-10XS-MIC or EX9200-20F-MIC, grasp the MIC ejector lever on the faceplate of the line card that is adjacent to the MIC and pull it outward until the MIC is fully unseated (see [Figure 87 on page 263](#)). If you are removing an EX9200-40T-MIC, grasp the MIC ejector levers on either side of the faceplate of the line card and pull them outward simultaneously until the MIC is fully unseated (see [Figure 88 on page 264](#)).
7. Grasp the handles on the MIC faceplate and slide the MIC out of the line card.



CAUTION: Do not stack MICs on top of one another or on top of any other component. Place each MIC separately in the antistatic bag or on the antistatic mat placed on a flat, stable surface.

8. Place the MIC in an antistatic bag or on its own antistatic mat placed on a flat, stable surface.
9. Install both the MIC slot cover panels if you will not install any MIC in the MIC slots, or install one cover panel in the empty portion of the MIC slot if you will install only one EX9200-10XS-MIC or EX9200-20F-MIC. Do this to protect the interior of the line card and the switch chassis from dust or other foreign substances and to ensure that the airflow inside the line card and the switch chassis is not disrupted.

Figure 87: Removing an EX9200-10XS-MIC or EX9200-20F-MIC

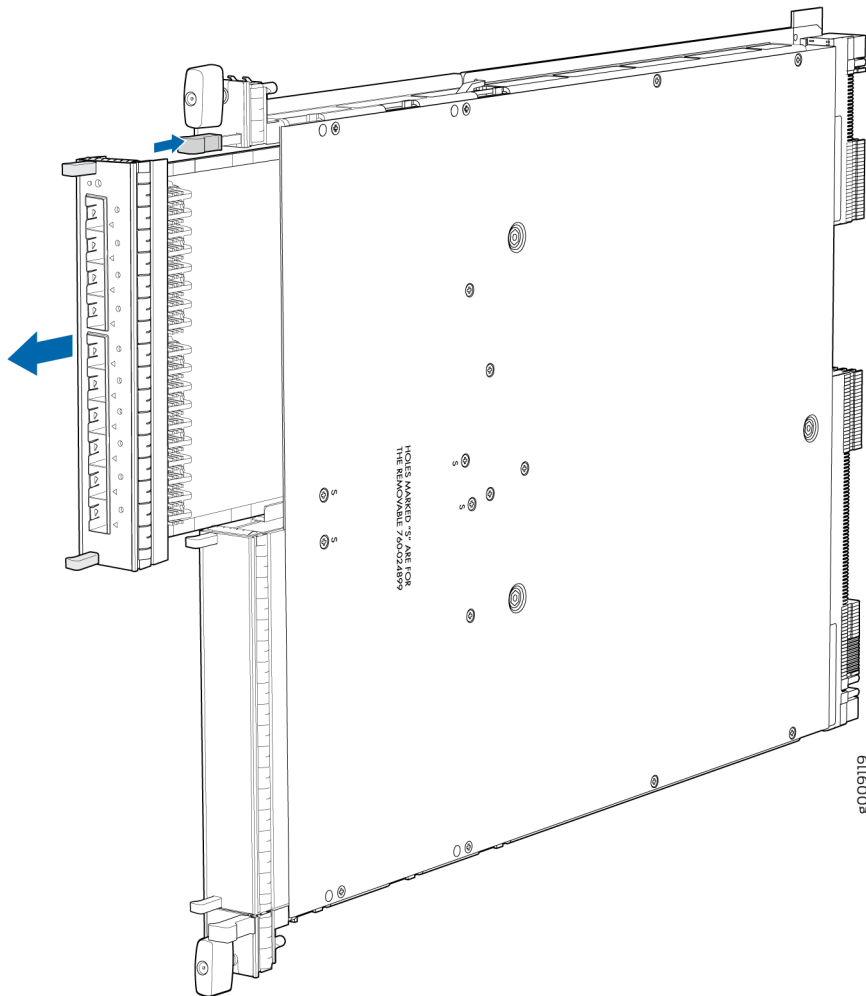
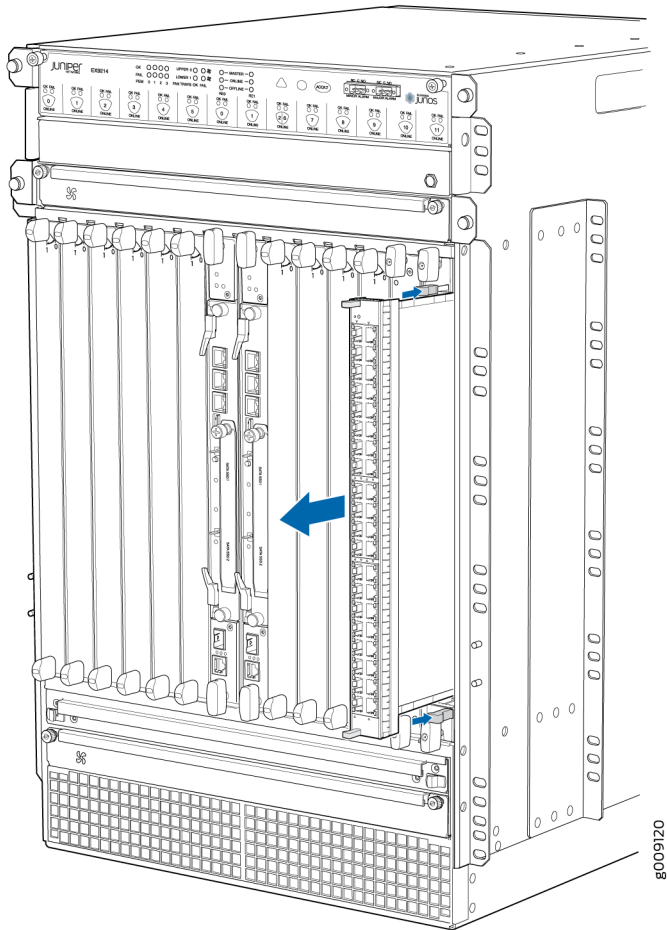

Figure 88: Removing an EX9200-40T-MIC



Installing a MIC in an EX9200-MPC Line Card

Before you begin installing a MIC in an EX9200-MPC line card:

- Ensure that you have taken the necessary precautions to prevent electrostatic discharge (ESD) damage (see *Prevention of Electrostatic Discharge Damage*).
- Ensure that you know how to handle and store the line card (see *Handling and Storing Line Cards*).

Ensure that you have the following parts and tools available:

- (If you will install only one EX9200-10XS-MIC or EX9200-20F-MIC) A septum and screws to secure the septum

- (If you will install only one EX9200-10XS-MIC or EX9200-20F-MIC) A cover panel and screws to secure the cover panel
- Rubber safety caps to cover transceivers
- ESD grounding strap
- Phillips (+) screwdriver, number 2

The EX9200-MPC line card accepts any of the following Modular Interface Cards (MICs):

- EX9200-10XS-MIC
- EX9200-20F-MIC
- EX9200-40T-MIC

The EX9200-MPC line card has two slots on the faceplate in which you can install the MICs. You can install the MICs in the following configurations:

- One EX9200-10XS-MIC
- One EX9200-20F-MIC
- One EX9200-10XS-MIC and one EX9200-20F-MIC
- Two EX9200-10XS-MICs
- Two EX9200-20F-MICs
- One EX9200-40T-MIC

The MICs are hot-insertable and hot-removable field replaceable units (FRUs): You can remove and replace them without powering off the switch or disrupting switch functions. However, if you remove a MIC, the interface for that MIC stops functioning.

To install a MIC in an EX9200-MPC line card:

1. Attach the ESD grounding strap to your bare wrist and connect the strap to the ESD point on the rear panel of EX9200 switches.
2. If the MIC slot on the line card has a cover panel on it, use the screwdriver to remove the captive screws on each side of the cover panel. Save the cover panel and the screws for later use.

NOTE: If you are installing only one MIC, ensure that the empty MIC slot is covered by a cover panel.

3. If you will install only one EX9200-10XS-MIC or EX9200-20F-MIC and if there is no septum installed in the line card, install the septum (see [Figure 89 on page 266](#)):

- a. Position the septum in the center of the MIC slot on the line card so that it is aligned with the holes labeled **S** on the top and bottom surfaces of the line card.
- b. Insert a screw each into the holes labeled **S** on the top surface of the line card and tighten the screws by using the screwdriver.
- c. Insert a screw each into the holes labeled **S** on the bottom surface of the line card and tighten the screws by using the screwdriver.

Figure 89: Installing the Septum

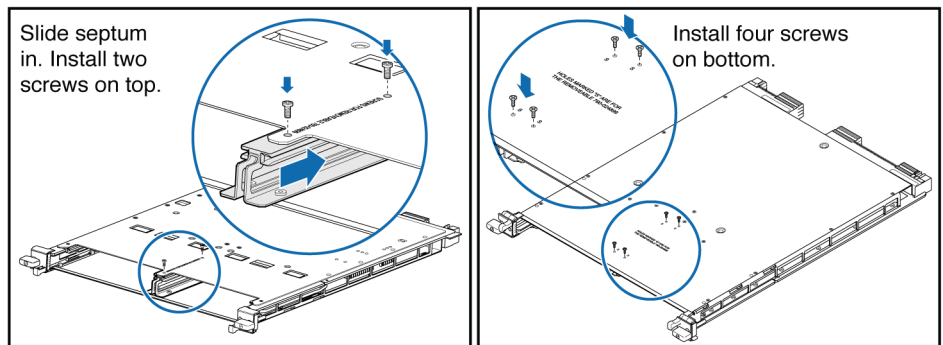

4. If you are installing an EX9200-40T-MIC and if there is a septum installed in the line card, remove the septum (see [Figure 90 on page 266](#)):
 - a. Remove the screws labeled **S** on the bottom surface of the line card.
 - b. Remove the two screws labeled **S** on the top surface of the line card.
 - c. Slide the septum out of the line card.
 - d. Save the septum and screws for later use.

Figure 90: Removing the Septum

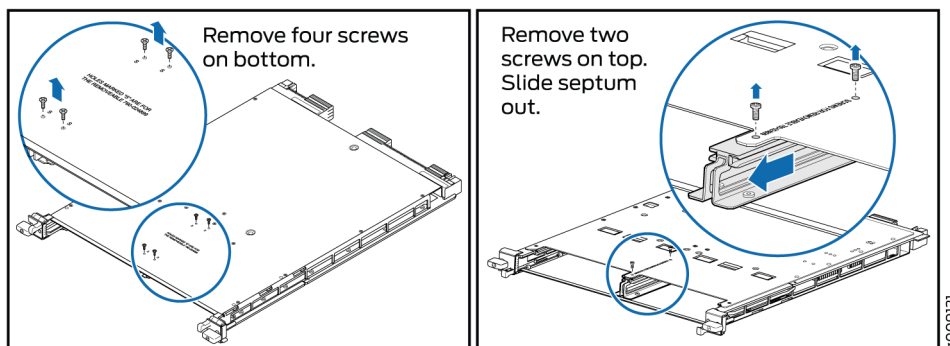



WARNING: Do not look directly into a fiber-optic transceiver or into the ends of fiber-optic cables. Fiber-optic transceivers and fiber-optic cable connected to a transceiver emit laser light that can damage your eyes.



CAUTION: Do not leave a fiber-optic transceiver uncovered, except when you are inserting or removing cable. The safety cap keeps the port clean and protects your eyes from accidental exposure to laser light.

5. If any transceiver is installed in the MIC, ensure that you cover it by using a rubber safety cap.
6. Align the MIC with the guides located along the sides of the MIC slot.



CAUTION: Before you slide the MIC into the slot, ensure that the MIC is aligned correctly. Misalignment might cause the pins to bend, making the MIC unusable.

7. Slide the MIC into the slot gently until it is fully seated (see [Figure 91 on page 268](#) or [Figure 92 on page 269](#)).
8. Push the MIC ejector lever on the line card that is adjacent to the MIC slot in which you are installing the MIC until the MIC is secured in position.
9. If you are installing only one EX9200-10XS-MIC or EX9200-20F-MIC, install a cover panel over the empty MIC slot and secure it with the captive screws by using the screwdriver. Do this to protect the interior of the chassis from dust or other foreign substances and to ensure that the airflow inside the chassis is not disrupted.
10. Bring the MIC online by pressing the power button on the MIC until the **OK/FAIL** LED on the MIC is lit green. You can also bring the MIC online by issuing the following CLI command:

```
user@host> request chassis mic fpc-slot slot-number mic-slot slot-number online
```

Figure 91: Installing an EX9200-10XS-MIC or EX9200-20F-MIC

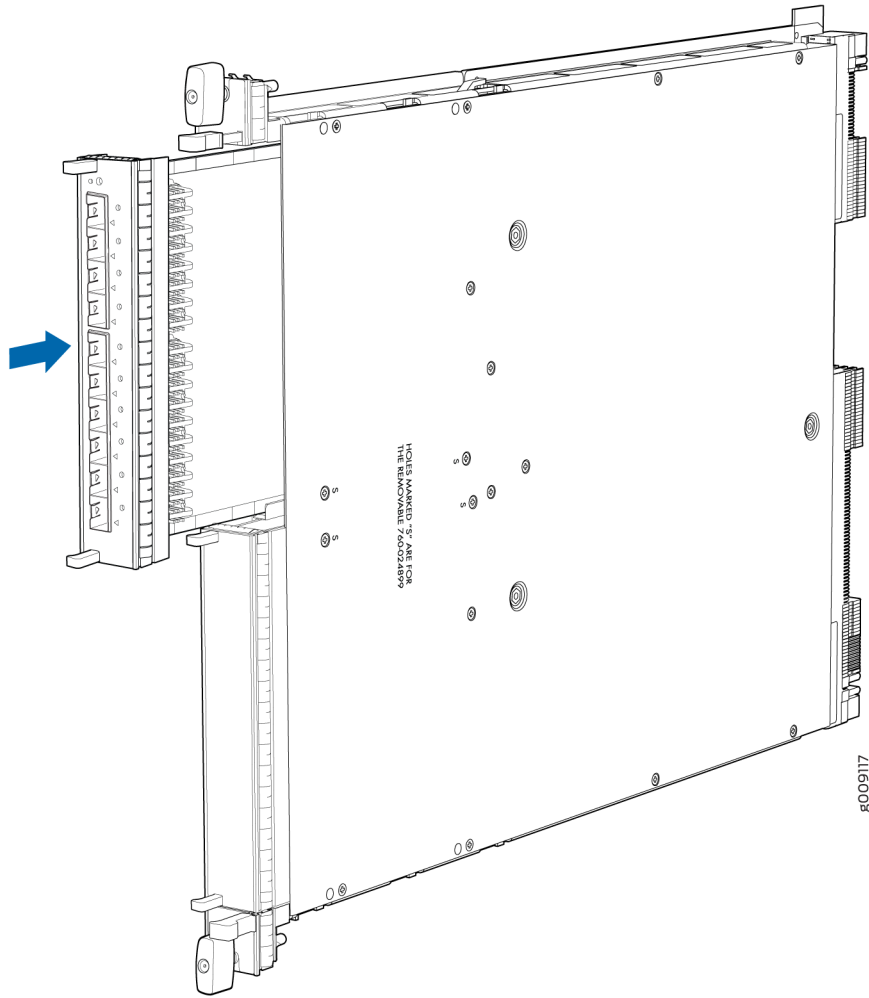
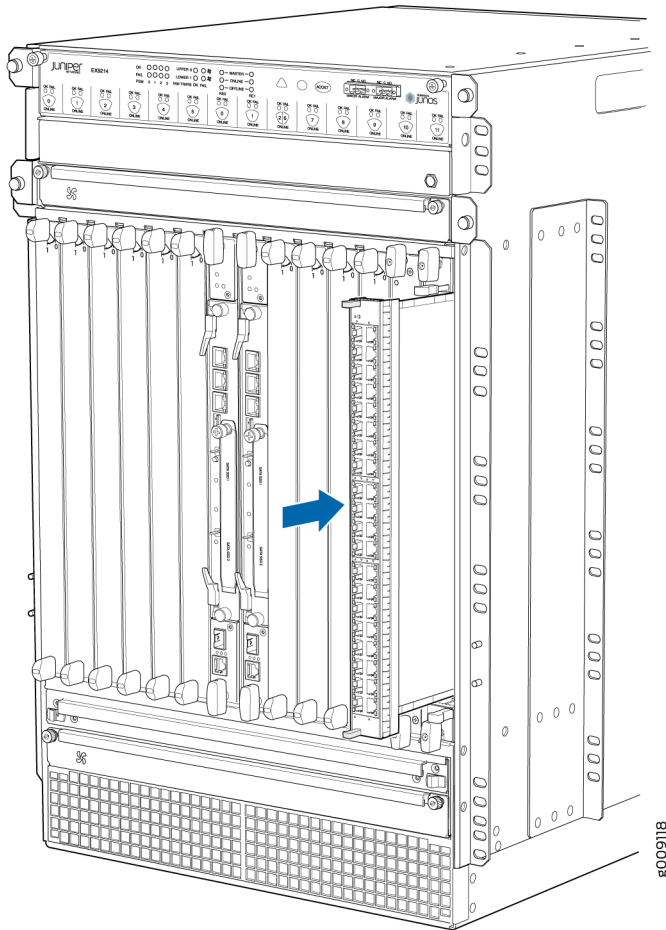

Figure 92: Installing an EX9200-40T-MIC



SEE ALSO

| [EX9200-MPC Line Card](#)

Maintain Transceivers

IN THIS SECTION

- [Remove a Transceiver | 270](#)

Remove a Transceiver

Before you remove a transceiver from a device, ensure that you have taken the necessary precautions for the safe handling of lasers (see *Laser and LED Safety Guidelines and Warnings*).

Ensure that you have the following parts and tools available:

- An antistatic bag or an antistatic mat
- Rubber safety caps to cover the transceiver and fiber-optic cable connector
- A dust cover to cover the port or a replacement transceiver

The transceivers for Juniper Networks devices are hot-removable and hot-insertable field-replaceable units (FRUs). You can remove and replace the transceivers without powering off the device or disrupting device functions.

NOTE: After you remove a transceiver, or when you change the media-type configuration, wait for 6 seconds for the interface to display the operational commands.

Figure 93 on page 272 shows how to remove a QSFP+ transceiver. The procedure is the same for all types of transceivers except the QSFP28 and CFP transceivers.

To remove a transceiver from a device:

1. Place the antistatic bag or antistatic mat on a flat, stable surface.
2. Wrap and fasten one end of the ESD wrist strap around your bare wrist, and connect the other end of the strap to the ESD point on the rack.
3. Label the cable connected to the transceiver so that you can reconnect it correctly.



LASER WARNING: Do not look directly into a fiber-optic transceiver or into the ends of fiber-optic cables. Fiber-optic transceivers and fiber-optic cables connected to transceivers emit laser light that can damage your eyes.



LASER WARNING: Do not leave a fiber-optic transceiver uncovered except when inserting or removing a cable. The rubber safety cap keeps the port clean and protects your eyes from accidental exposure to laser light.



CAUTION: Do not bend fiber-optic cables beyond their minimum bend radius. An arc smaller than a few inches in diameter can damage the cables and cause problems that are difficult to diagnose.

4. Remove the cable connected to the transceiver (see *Disconnect a Fiber-Optic Cable*). Cover the transceiver and the end of each fiber-optic cable connector with a rubber safety cap immediately after disconnecting the fiber-optic cables.
5. If there is a cable management system, arrange the cable in the cable management system to prevent it from dislodging or developing stress points. Secure the cable so that it does not support its own weight as it hangs to the floor. Place excess cable out of the way in a neatly coiled loop in the cable management system. Placing fasteners on the loop helps to maintain its shape.



CAUTION: Do not bend the fiber-optic cable beyond its minimum bend radius. An arc smaller than a few inches in diameter can damage the cable and cause problems that are difficult to diagnose.

6. To remove an SFP56-DD, SFP, SFP+, XFP, a QSFP+, or QSFP56-DD transceiver:
 - a. Using your fingers, pull open the ejector lever on the transceiver to unlock the transceiver. Note that QSFP-DD and SFP-DD transceivers don't have ejector levers, they have a pull tab instead which can be used to unlock and remove the transceiver.



CAUTION: Before removing the transceiver, make sure that you open the ejector lever completely until you hear it click. This precaution prevents damage to the transceiver.

- b. Grasp the transceiver ejector lever and gently slide the transceiver approximately 0.5 in. (1.3 cm) straight out of the port.



CAUTION: To prevent ESD damage to the transceiver, do not touch the connector pins at the end of the transceiver.

Figure 93: Remove a QSFP+ Transceiver

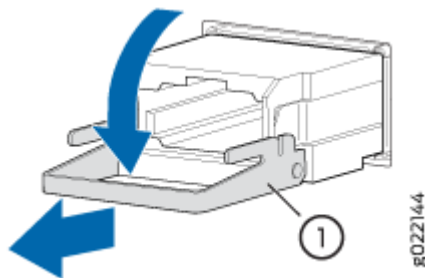

1– Ejector lever

To remove a CFP transceiver:

- a. Using your fingers, loosen the screws on the transceiver.
- b. Grasp the screws on the transceiver and gently slide the transceiver approximately 0.5 in. (1.3 cm) straight out of the port.



CAUTION: To prevent ESD damage to the transceiver, do not touch the connector pins at the end of the transceiver.

7. Using your fingers, grasp the body of the transceiver and pull it straight out of the port.
8. Place the transceiver in the antistatic bag or on the antistatic mat placed on a flat, stable surface.
9. Place the dust cover over the empty port, or install the replacement transceiver.

Install a Transceiver

Before you install a transceiver in a device, ensure that you have taken the necessary precautions for safe handling of lasers (see [Laser and LED Safety Guidelines and Warnings](#)).

Ensure that you have a rubber safety cap available to cover the transceiver.

The transceivers for Juniper Networks devices are hot-removable and hot-insertable field-replaceable units (FRUs). You can remove and replace the transceivers without powering off the device or disrupting the device functions.

NOTE: After you insert a transceiver or after you change the media-type configuration, wait for 6 seconds for the interface to display operational commands.

NOTE: We recommend that you use only optical transceivers and optical connectors purchased from Juniper Networks with your Juniper Networks device.



CAUTION: The Juniper Networks Technical Assistance Center (JTAC) provides complete support for Juniper-supplied optical modules and cables. However, JTAC does not provide support for third-party optical modules and cables that are not qualified or supplied by Juniper Networks. If you face a problem running a Juniper device that uses third-party optical modules or cables, JTAC may help you diagnose host-related issues if the observed issue is not, in the opinion of JTAC, related to the use of the third-party optical modules or cables. Your JTAC engineer will likely request that you check the third-party optical module or cable and, if required, replace it with an equivalent Juniper-qualified component.

Use of third-party optical modules with high-power consumption (for example, coherent ZR or ZR+) can potentially cause thermal damage to or reduce the lifespan of the host equipment. Any damage to the host equipment due to the use of third-party optical modules or cables is the users' responsibility. Juniper Networks will accept no liability for any damage caused due to such use.

[Figure 94 on page 275](#) shows how to install a QSFP+ transceiver. The procedure is the same for all types of transceivers except the QSFP28 and CFP transceivers.

To install a transceiver:



CAUTION: To prevent electrostatic discharge (ESD) damage to the transceiver, do not touch the connector pins at the end of the transceiver.

1. Wrap and fasten one end of the ESD wrist strap around your bare wrist, and connect the other end of the strap to the ESD point on the switch.
2. Remove the transceiver from its bag.
3. Check to see whether the transceiver is covered with a rubber safety cap. If it is not, cover the transceiver with a rubber safety cap.



LASER WARNING: Do not leave a fiber-optic transceiver uncovered except when inserting or removing a cable. The rubber safety cap keeps the port clean and protects your eyes from accidental exposure to laser light.

4. If the port in which you want to install the transceiver is covered with a dust cover, remove the dust cover and save it in case you need to cover the port later. If you are hot-swapping a transceiver, wait for at least 10 seconds after removing the transceiver from the port before installing a new transceiver.
5. Using both hands, carefully place the transceiver in the empty port. The connectors must face the chassis.



CAUTION: Before you slide the transceiver into the port, ensure that the transceiver is aligned correctly. Misalignment might cause the pins to bend, making the transceiver unusable.

6. Slide the transceiver in gently until it is fully seated. If you are installing a CFP transceiver, use your fingers to tighten the captive screws on the transceiver.
7. Remove the rubber safety cap from the transceiver and the end of the cable, and insert the cable into the transceiver.



LASER WARNING: Do not look directly into a fiber-optic transceiver or into the ends of fiber-optic cables. Fiber-optic transceivers and fiber-optic cable connected to a transceiver emit laser light that can damage your eyes.



CAUTION: Do not leave a fiber-optic transceiver uncovered except when inserting or removing cable. The safety cap keeps the port clean and protects your eyes from accidental exposure to laser light.

8. If there is a cable management system, arrange the cable in the cable management system to prevent the cable from dislodging or developing stress points. Secure the cable so that it does not support its own weight as it hangs toward the floor. Place excess cable out of the way in a neatly coiled loop in the cable management system. Placing fasteners on the loop helps to maintain its shape.

CAUTION: Do not let fiber-optic cable hang free from the connector. Do not allow fastened loops of cable to dangle, which stresses the cable at the fastening point.

CAUTION: Avoid bending fiber-optic cable beyond its minimum bend radius. An arc smaller than a few inches in diameter can damage the cable and cause problems that are difficult to diagnose.

NOTE: When you install SFP-DD transceivers, push it hard until you hear a click sound. Use a long nose plier to pull the SFP-DD transceiver connected on the top and bottom rows of the chassis where the pull tabs face each other.

NOTE: Make sure to use a dust cap to cover ports that are unused.

NOTE: While using Finisar AOC SFP+ optical module with the QFX5130-48C switch, you may need to pull the module upwards to pull out the module smoothly from the cage.

NOTE: "

Figure 94: Install a Transceiver

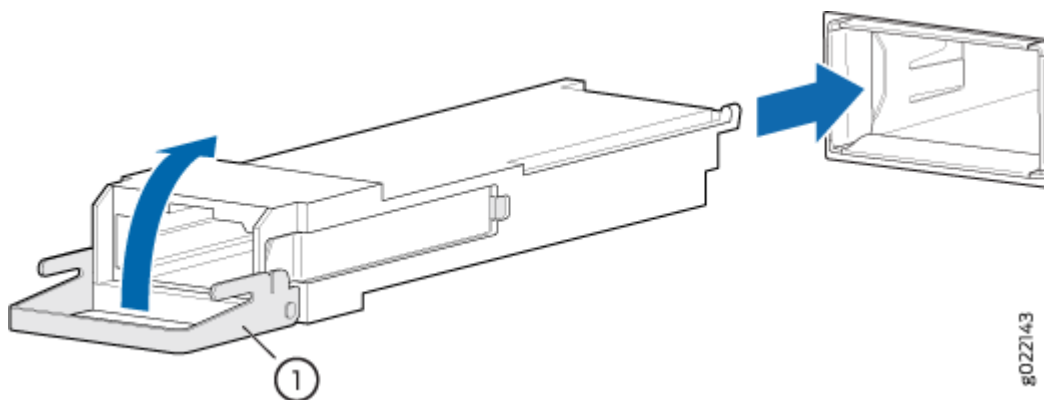

Maintaining Alarm Relay Wire

IN THIS SECTION

- [Disconnecting the Alarm Relay Wires from the Craft Interface in an EX9200 Switch | 276](#)
- [Connecting the Alarm Relay Wires to the Craft Interface in an EX9200 Switch | 277](#)

Disconnecting the Alarm Relay Wires from the Craft Interface in an EX9200 Switch

Ensure that you have the following parts and tools available:

- Electrostatic discharge (ESD) grounding strap
- 2.5-mm flat-blade (-) screwdriver

The craft interface has two alarm relay contacts for connecting the switch to external alarm devices (see [Figure 95 on page 277](#)).

To disconnect the alarm relay wires from the switch and the alarm-reporting device:

1. Disconnect the wire at the external device.
2. Wrap and fasten one end of the ESD wrist strap around your bare wrist, and connect the other end of the strap to the ESD point on the switch.
3. Loosen the small screws on the face of the terminal block using a screwdriver and remove the block from the relay contact.
4. Loosen the small screws on the side of the terminal block using a screwdriver. Remove existing wires from the slots in the front of the block.

Figure 95: Alarm Relay Contacts

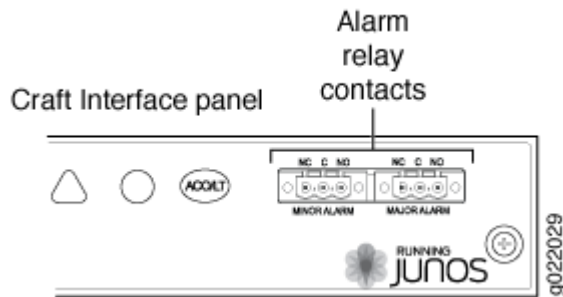

Connecting the Alarm Relay Wires to the Craft Interface in an EX9200 Switch

Before you connect the alarm relay wires between a switch and an alarm-reporting device:

- Ensure you understand how to prevent electrostatic discharge (ESD) damage. See *Prevention of Electrostatic Discharge Damage*.

Ensure that you have the following parts and tools available:

- An ESD wrist strap
- 2.5 mm flat-blade screwdriver

To connect the alarm relay wires between a switch and an alarm-reporting device (see [Figure 96 on page 278](#)):

1. Prepare the required length of replacement wire with gauge between 28 AWG (0.08 mm²) and 14 AWG (2.08 mm²).
2. Insert the replacement wires into the slots in the front of the block. Use the screwdriver to tighten the screws and secure the wire.
3. Wrap and fasten one end of the ESD wrist strap around your bare wrist, and connect the other end of the strap to the ESD point on the switch.
4. Plug the terminal block into the relay contact, and use the screwdriver to tighten the screws on the face of the block.
5. Attach the other end of the wires to the external device.

Figure 96: Alarm Relay Contacts

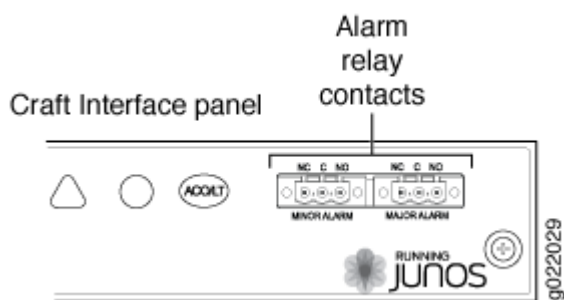
**SEE ALSO**

Connecting the EX9200 Switch to an External Alarm-Reporting Device
Craft Interface in an EX9200 Switch

Maintain Fiber-Optic Cables

IN THIS SECTION

- [Connect a Fiber-Optic Cable | 278](#)
- [Disconnect a Fiber-Optic Cable | 279](#)
- [How to Handle Fiber-Optic Cables | 280](#)

Connect a Fiber-Optic Cable

Before you connect a fiber-optic cable to an optical transceiver installed in a device, ensure that you have taken the necessary precautions for safe handling of lasers (see *Laser and LED Safety Guidelines and Warnings*).

To connect a fiber-optic cable to an optical transceiver installed in a device:



LASER WARNING: Do not look directly into a fiber-optic transceiver or into the ends of fiber-optic cables. Fiber-optic transceivers and fiber-optic cables connected to transceivers emit laser light that can damage your eyes.

1. If the fiber-optic cable connector is covered with a rubber safety cap, remove the cap. Save the cap.
2. Remove the rubber safety cap from the optical transceiver. Save the cap.
3. Insert the cable connector into the optical transceiver (see [Figure 97 on page 279](#)).

Figure 97: Connect a Fiber-Optic Cable to an Optical Transceiver Installed in a Device

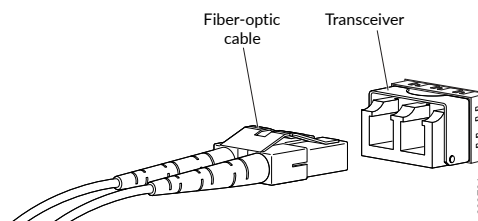

4. Secure the cables so that they do not support their own weight. Place excess cable out of the way in a neatly coiled loop. Placing fasteners on a loop helps cables maintain their shape.



CAUTION: Do not bend fiber-optic cables beyond their minimum bend radius. An arc smaller than a few inches in diameter can damage the cables and cause problems that are difficult to diagnose.

Do not let fiber-optic cables hang free from the connector. Do not allow fastened loops of cables to dangle, which stresses the cables at the fastening point.

Disconnect a Fiber-Optic Cable

Before you disconnect a fiber-optic cable from an optical transceiver, ensure that you have taken the necessary precautions for safe handling of lasers. See *Laser and LED Safety Guidelines and Warnings*.

Ensure that you have the following parts and tools available:

- A rubber safety cap to cover the transceiver
- A rubber safety cap to cover the fiber-optic cable connector

Juniper Networks devices have optical transceivers to which you can connect fiber-optic cables.

To disconnect a fiber-optic cable from an optical transceiver installed in the device:

1. Disable the port in which the transceiver is installed by issuing the following command:

```
[edit interfaces]
user@device# set interface-name disable
```



LASER WARNING: Do not look directly into a fiber-optic transceiver or into the ends of fiber-optic cables. Fiber-optic transceivers and fiber-optic cables connected to transceivers emit laser light that can damage your eyes.

2. Carefully unplug the fiber-optic cable connector from the transceiver.
3. Cover the transceiver with a rubber safety cap.



LASER WARNING: Do not leave a fiber-optic transceiver uncovered except when inserting or removing a cable. The rubber safety cap keeps the port clean and protects your eyes from accidental exposure to laser light.

4. Cover the fiber-optic cable connector with the rubber safety cap.

How to Handle Fiber-Optic Cables

Fiber-optic cables connect to optical transceivers that are installed in Juniper Networks devices.

Follow these guidelines when handling fiber-optic cables:

- When you unplug a fiber-optic cable from a transceiver, place rubber safety caps over the transceiver and on the end of the cable.
- Anchor fiber-optic cables to prevent stress on the connectors. When attaching a fiber-optic cable to a transceiver, be sure to secure the fiber-optic cable so that it does not support its own weight as it hangs to the floor. Never let a fiber-optic cable hang free from the connector.
- Avoid bending fiber-optic cables beyond their minimum bend radius. Bending fiber-optic cables into arcs smaller than a few inches in diameter can damage the cables and cause problems that are difficult to diagnose.
- Frequent plugging and unplugging of fiber-optic cables in and out of optical instruments can damage the instruments, which are expensive to repair. To prevent damage from overuse, attach a short fiber

extension to the optical equipment. The short fiber extension absorbs wear and tear due to frequent plugging and unplugging, which is easier and less expensive to replace than the instruments.

- Keep fiber-optic cable connections clean. Microdeposits of oil and dust in the canal of the transceiver or cable connector can cause loss of light, reduction in signal power, and possibly intermittent problems with the optical connection.
 - To clean the transceiver canal, use an appropriate fiber-cleaning device such as RIFOCS Fiber Optic Adaptor Cleaning Wands (part number 946). Follow the instructions in the cleaning kit you use.
 - After cleaning the transceiver, make sure that the connector tip of the fiber-optic cable is clean. Use only an approved alcohol-free fiber-optic cable cleaning kit such as the Opptex Cletop-S® Fiber Cleaner. Follow the instructions in the cleaning kit you use.

Maintaining the EX9208 Cable Management Brackets

IN THIS SECTION

- [Installing Cable Management Brackets on an EX9208 Switch | 281](#)
- [Removing Cable Management Brackets from an EX9208 Switch | 283](#)

Installing Cable Management Brackets on an EX9208 Switch

Before you install cable management brackets on the switch:

- Ensure you understand how to prevent electrostatic discharge (ESD) damage. See *Prevention of Electrostatic Discharge Damage*.

Ensure that you have the following parts and tools available to install cable management brackets on an EX9208 switch chassis:

- ESD grounding strap
- Phillips (+) screwdriver, number 1 and 2

The cable management brackets attach to both sides of the switch. To install the cable management brackets (see [Figure 98 on page 282](#)):

1. Attach the ESD grounding strap to your bare wrist, and connect the strap to the ESD point on the chassis.
2. Position the cable management brackets on the front sides of the chassis.
3. Insert the tabs into the slots.
4. Tighten the captive screws completely.

Figure 98: Installing the Cable Management Brackets in an EX9208 Switch

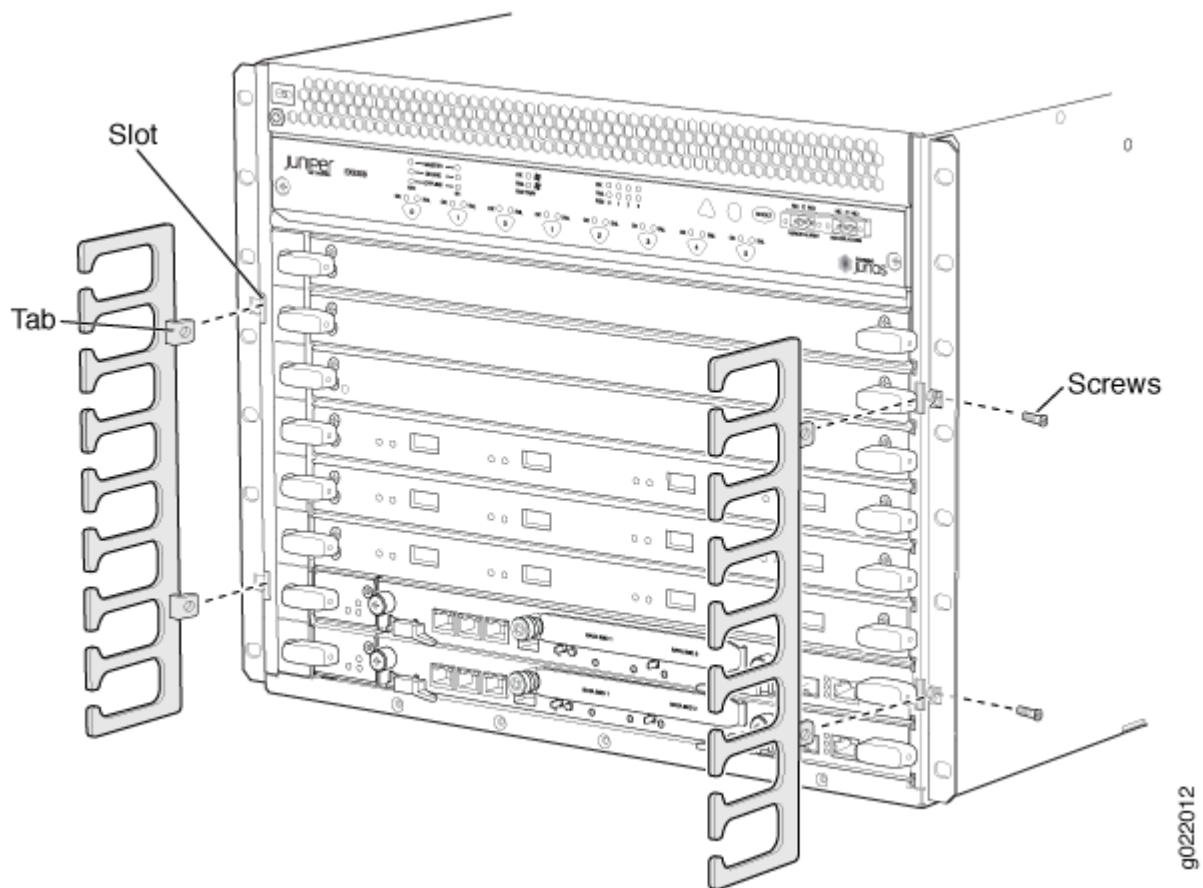

SEE ALSO

[Cable Management Brackets in an EX9208 Switch | 49](#)

Removing Cable Management Brackets from an EX9208 Switch

Ensure that you have the following parts and tools available to remove the cable management brackets from an EX9208 switch chassis:

- Electrostatic discharge (ESD) grounding strap
- Phillips (+) screwdriver, number 1 and 2

To remove the cable management brackets:

1. Attach an ESD grounding strap to your bare wrist, and connect the strap to one of the ESD points on the chassis.
2. Loosen the captive screws on either side of the chassis by using the screw driver.
3. Remove the cable management brackets.

Removing an EX9208 from a Rack or Cabinet

IN THIS SECTION

- [Powering Off an EX9200 Switch | 283](#)
- [Removing an EX9200 Switch from a Rack or Cabinet Using a Mechanical Lift | 284](#)
- [Removing an EX9208 Switch from a Rack or Cabinet Without Using a Mechanical Lift | 285](#)

Powering Off an EX9200 Switch

Before you power off the switch:

- Ensure that you understand how to prevent electrostatic discharge (ESD) damage. See *Prevention of Electrostatic Discharge Damage*.

Ensure that you have the following parts and tools available to power off the switch:

- An ESD wrist strap
- An external management device such as a PC

- A cable to connect the external management device to the console port (**CONSOLE**) or management port (<...>) on the primary Routing Engine module (RE module).

To power off the switch:

1. Connect a management console device to the primary RE module. For information about connecting a management device to the console (**CONSOLE**) port, see *Connecting an EX9200 Switch to a Management Console or an Auxiliary Device*. For information about connecting a management device to the Ethernet management (<...>) port, see *Connecting an EX9200 Switch to a Network for Out-of-Band Management*.

2. On the external management device connected to the Routing Engine, issue the `request system halt both-routing-engines operational mode` command. The command shuts down the Routing Engines cleanly, so their state information is preserved. (If the switch contains only one Routing Engine, issue the `request system halt` command.)

For more information about these commands, see the Junos OS Operational Mode Commands.

3. Wait until a message appears on the console confirming that the operating system has halted.
4. Wrap and fasten one end of the ESD wrist strap around your bare wrist, and connect the other end of the strap to the ESD point on the switch.
5. Move the AC input switch on each AC power supply or the DC circuit breaker on each DC power supply to the Off (O) position.

SEE ALSO

Powering On an AC-Powered EX9200 Switch

Powering On a DC-Powered EX9200 Switch

Removing an EX9200 Switch from a Rack or Cabinet Using a Mechanical Lift

Before you remove the switch using a lift:

- Ensure that the rack or cabinet is stable and secured to the building.
- Ensure that there is enough space to place the removed switch in its new location and shift it along the path to the new location.
- Read *General Safety Guidelines and Warnings*, with particular attention to [Chassis Lifting Guidelines for EX9200 Switches](#).

- Ensure that the switch has been safely powered off (see *Powering Off an EX9200 Switch*) and that you have disconnected the power cords from the power supplies.
- Ensure that you have disconnected any cables or wires attached to the switch ports.

Ensure that you have the following parts and tools available:

- A mechanical lift
- A Phillips (+) screwdrivers, number 1 and 2

Considering the size and weight of the switch, we strongly recommend you use a mechanical lift to remove the switch.



CAUTION: When removing more than one switch from a rack or cabinet, remove the switch in the top of the rack or cabinet first and proceed to remove the rest of the switches from top to bottom.

To remove the switch using a lift:

1. Use the appropriate screwdriver to remove the mounting screws that attach the chassis front-mounting brackets to the rack or cabinet.
2. Move the lift to the rack and position it so that its platform is centered about 0.5 in. (1.27 cm) below the bottom of the switch chassis and as close to it as possible.
3. Carefully slide the switch from the adjustable mounting brackets attached to the rack onto the lift.
4. Use the lift to transport the switch to its new location.

Removing an EX9208 Switch from a Rack or Cabinet Without Using a Mechanical Lift

Before you remove the switch:

- Ensure that the rack or cabinet is stable and secured to the building.
- Ensure that there is enough space to place the removed switch in its new location and shift it along the path to the new location.
- Review chassis lifting guidelines as described in [Chassis Lifting Guidelines for EX9200 Switches](#).
- Ensure that the switch has been safely powered off (see *Powering Off an EX9200 Switch*) and that you have unplugged (disconnected) the power cords to the power supplies.
- Ensure that you have disconnected any cables or wires attached to the switch ports.

- Remove all components except the midplane from the chassis. See:
 - *Removing an SF Module from an EX9200 Switch*
 - *Removing a Line Card from an EX9200 Switch*
 - *Removing a Fan Tray from an EX9200 Switch*
 - ["Removing an AC Power Supply from an EX9208 Switch" on page 221](#)
 - ["Removing a DC Power Supply from an EX9208 Switch" on page 224](#)

Ensure that you have the following parts and tools available to remove the switch:

- A Phillips (+) screwdriver, number 2 or number 3, depending on the size of your rack mounting screws

If you cannot use a mechanical lift to remove an EX9208 switch from a rack or a cabinet (the preferred method), you can remove it manually.



CAUTION: The chassis with only the backplane and no other components weighs approximately 65.5 lb (29.7 kg). Lifting the chassis and removing it from a rack or cabinet requires at least three people.

The chassis has two handles. Do not lift a fully loaded chassis by the handles; make sure the chassis is empty before you lift it. If two of the people lifting the chassis use the handles to lift it, the third person must lift from the rear of the chassis. The rear of the chassis is heavier than the front of the chassis, so when you lift the chassis by the handles, the chassis tips toward the heavier back end. The person lifting from the back must be aware of this behavior and must be braced to prevent the chassis from tipping over.

When lifting the chassis, do not grasp the switch by the blue panel at the top front of the chassis. Doing so can cause the panel to pop off of the switch.



CAUTION: When removing more than one switch from a rack, remove the switch at the top first. We strongly recommend removing a switch that is in an upper position in a rack or cabinet with a lift.

To remove the switch from the rack:

1. Use the appropriate screwdriver to remove the 24 mounting screws that attach the chassis front-mounting brackets to the rack or cabinet.



WARNING: To prevent injury, keep your back straight and lift with your legs, not your back. Do not twist your body as you lift. Balance the load evenly and be sure that your footing is firm.

2. With one person on each side and one person at the back, hold onto the bottom of the chassis and carefully lift it out of the adjustable mounting brackets attached to the rack. If you have a pallet jack, move the switch onto the pallet jack.
3. Carefully move the chassis to its new location.

After you move the switch to its new location, reinstall the components in the chassis or store the components in antistatic bags. See:

- *Installing an SF Module in an EX9200 Switch*
- *Installing a Line Card in an EX9200 Switch*
- *Installing a Fan Tray in an EX9200 Switch*
- ["Installing an AC Power Supply in an EX9208 Switch" on page 222](#)
- ["Installing a DC Power Supply in an EX9208 Switch" on page 226](#)

6

CHAPTER

Troubleshooting Hardware

Troubleshooting EX9200 Components | 289

Troubleshooting EX9200 Components

IN THIS SECTION

- [Troubleshooting the Cooling System in an EX9200 Switch | 289](#)
- [Troubleshooting Power Supplies in an EX9200 Switch | 290](#)
- [Troubleshooting Line Cards in EX9200 Switches | 292](#)
- [Troubleshooting Traffic Drops on EX9200-6QS Line Cards | 295](#)
- [Understand Alarm Types and Severity Levels on EX Series Switches | 296](#)
- [Chassis Component Alarm Conditions on EX9200 Switches | 298](#)
- [Monitor System Log Messages | 306](#)
- [Troubleshoot Temperature Alarms in EX Series Switches | 313](#)

Troubleshooting the Cooling System in an EX9200 Switch

IN THIS SECTION

- [Problem | 289](#)
- [Cause | 289](#)
- [Solution | 290](#)

Problem

Description

The fans in the fan tray are not functioning normally.

Cause

Solution

Follow these guidelines to troubleshoot the fans:

- Check the fan LEDs and alarm LEDs on the craft interface.

If the major alarm LED on the craft interface glows, use the CLI to get information about the source of an alarm condition:

```
user@switch> show chassis alarms
```

If the CLI output lists only one fan failure and the other fans are functioning normally, the fan is most likely faulty and you must replace the fan tray.

- Place your hand near the exhaust vents at the side of the chassis to determine whether the fans are pushing air out of the chassis.
- If a fan tray is removed, both a minor alarm and a major alarm occur.
- The following conditions automatically cause the fans to run at full speed and also trigger the indicated alarm:
 - A fan fails (major alarm).
 - The switch temperature exceeds the *temperature warm* threshold (minor alarm).
 - The temperature of the switch exceeds the *temperature hot* threshold (major alarm and automatic shutdown of the power supplies).

Troubleshooting Power Supplies in an EX9200 Switch

IN THIS SECTION

- [Problem | 291](#)
- [Cause | 291](#)
- [Solution | 291](#)

Problem

Description

The power system is not functioning normally.

Cause

Solution

- Check the LEDs on each power supply faceplate.
 - If an AC power supply is correctly installed and functioning normally, the **AC OK** and **DC OK** LEDs light steadily, and the **PS FAIL** LED is not lit.
 - If a DC power supply is correctly installed and functioning normally, the **PWR OK**, **BRKR ON**, and **INPUT OK** LEDs glow steady green.
- Issue the CLI `show chassis environment pem` command to check the status of installed power supplies. As shown in the sample output, the value `Online` in the rows labeled `State` must indicate that each of the power supplies is functioning normally.

```

user@switch> show chassis environment pem
PEM 0 status:
  State           Online
  Temperature     OK
  DC Output       Voltage(V) Current(A) Power(W) Load(%)
                  48         12         576    36
PEM 1 status:
  State           Online
  Temperature     OK
  DC Output       Voltage(V) Current(A) Power(W) Load(%)
                  50         12         600    37

```

The output is of an EX9208 switch. The output is similar for EX9204 and EX9214 switches.

If a power supply is not functioning normally, perform the following steps to diagnose and correct the problem:

- If a major alarm condition occurs, issue the `show chassis alarms` command to determine the source of the problem.

- If all power supplies have failed, the system temperature might have exceeded the threshold, causing the system to shut down.

NOTE: If the system temperature exceeds the threshold, Junos OS shuts down all power supplies so that no status is displayed.

Junos OS also can shut down one of the power supplies for other reasons. In this case, the remaining power supplies provide power to the switch, and you can still view the system status through the CLI or display.

- Check that the DC circuit breaker or AC input switch is in the on position and that the power supply is receiving power.
- Verify that the source circuit breaker has the proper current rating. Each power supply must be connected to a separate source circuit breaker.
- Verify that the AC power cord or DC power cables from the power source to the switch are not damaged. If the insulation is cracked or broken, immediately replace the cord or cable.
- Connect the power supply to a different power source with a new power cord or power cables. If the power supply status LEDs indicate that the power supply is not operating normally, the power supply is the source of the problem. Replace the power supply with a spare.

Troubleshooting Line Cards in EX9200 Switches

IN THIS SECTION

- [Problem | 292](#)
- [Solution | 293](#)

Problem

Description

Line card is not functioning normally.

Solution

- Monitor the LED labeled **OK** on the craft interface as soon as a line card is seated in an operating switch.

The Routing Engine downloads the line card software to it under two conditions: the line card is present when the Routing Engine boots Junos OS, and the line card is installed and requested online through the CLI or the button on the front panel. The line card then runs diagnostics, during which the **OK** LED blinks. When the line card is online and functioning normally, the **OK** LED is lit green steadily.

- Make sure the line card is properly seated in the midplane. Check that each ejector handle has been turned clockwise and is tight.
- Check the **OK/FAIL** LED on the line card and **OK** and **FAIL** line card LEDs on the craft interface. When the line card is online and functioning normally, the **OK** LED is lit green steadily.
- Issue the `show chassis fpc` command to check the status of installed line cards. As shown in the sample output, the value `Online` in the column labeled `State` indicates that the line card is functioning normally:

```
user@switch> show chassis fpc
```

Slot	State	Temp (C)	CPU Utilization (%) Total	Interrupt	Memory DRAM (MB)	Utilization (%) Heap	Buffer
0	Online	30	8	0	2048	24	14
1	Online	30	9	0	2048	14	14
2	Online	30	7	0	2048	14	14
3	Online	30	10	0	2048	14	14
4	Online	30	9	0	2048	15	14
5	Online	31	10	0	2048	15	14

NOTE: The `show chassis fpc` command displays the status of the line cards.

For more detailed output, add the `detail` option. The following example does not specify a slot number, which is optional:

```
user@switch> show chassis fpc detail
```

Slot 0 information:

State	Online
-------	--------

```
Temperature                30
Total CPU DRAM              2048 MB
Total RLDRAM                 331 MB
Total DDR DRAM              1536 MB
Start time:                  2013-02-22 22:29:57 PST
Uptime:                      2 days, 3 hours, 48 minutes, 56 seconds
Max Power Consumption        239 Watts

Slot 1 information:
State                        Online
Temperature                  30
Total CPU DRAM              2048 MB
Total RLDRAM                 331 MB
Total DDR DRAM              1536 MB
Start time:                  2013-02-22 22:30:01 PST
Uptime:                      2 days, 3 hours, 48 minutes, 52 seconds
Max Power Consumption        239 Watts

Slot 2 information:
State                        Online
Temperature                  30
Total CPU DRAM              2048 MB
Total RLDRAM                 331 MB
Total DDR DRAM              1536 MB
Start time:                  2013-02-22 22:30:04 PST
Uptime:                      2 days, 3 hours, 48 minutes, 49 seconds
Max Power Consumption        239 Watts

Slot 3 information:
State                        Online
Temperature                  30
Total CPU DRAM              2048 MB
Total RLDRAM                 331 MB
Total DDR DRAM              1536 MB
Start time:                  2013-02-22 22:30:08 PST
Uptime:                      2 days, 3 hours, 48 minutes, 45 seconds
Max Power Consumption        239 Watts

Slot 4 information:
State                        Online
Temperature                  30
Total CPU DRAM              2048 MB
Total RLDRAM                 331 MB
Total DDR DRAM              1536 MB
Start time:                  2013-02-22 22:30:10 PST
Uptime:                      2 days, 3 hours, 48 minutes, 43 seconds
Max Power Consumption        239 Watts
```

Slot 5 information:

State	Online
Temperature	31
Total CPU DRAM	2048 MB
Total RLDRAM	331 MB
Total DDR DRAM	1536 MB
Start time:	2013-02-22 22:30:16 PST
Uptime:	2 days, 3 hours, 48 minutes, 37 seconds
Max Power Consumption	239 Watts

SEE ALSO

| *Line Card Model and Version Compatibility in an EX9200 Switch*

Troubleshooting Traffic Drops on EX9200-6QS Line Cards

IN THIS SECTION

- [Problem | 295](#)
- [Cause | 296](#)
- [Solution | 296](#)

Problem**Description**

The EX9200-6QS line card drops all routed traffic, including both data plane and control plane traffic.

Environment

The switch in which the EX9200-6QS line card is installed runs Junos OS Release 14.2R1 and an IRB logical interface is configured on the line card as part of a VLAN.

Cause

On EX9200 switches, if an IRB logical interface is configured on an EX9200-6QS line card as part of a VLAN, any device that is connected through that interface is unable to route traffic outside of the subnet because the EX9200-6QS line card drops all ARP requests. This happens because even though the minimum Junos OS release that supports the EX9200-6QS line card is Junos OS Release 14.2R1, this release does not support a configuration that includes an IRB logical interface configured on an EX9200-6QS line card as part of a VLAN.

Solution

Upgrade Junos OS to the release specified in [TSB16659](#).

SEE ALSO

| [EX9200-6QS Line Card](#)

Understand Alarm Types and Severity Levels on EX Series Switches

NOTE: This topic applies only to the J-Web Application package.

Alarms alert you to conditions that might prevent normal operation of the switch. Before monitoring alarms on a Juniper Networks EX Series Ethernet switch, become familiar with the terms defined in [Table 64 on page 296](#).

Table 64: Alarm Terms

Term	Definition
alarm	Signal alerting you to conditions that might prevent normal operation. On a switch, the alarm signal is the ALM LED lit on the front of the chassis.
alarm condition	Failure event that triggers an alarm.

Table 64: Alarm Terms (*Continued*)

Term	Definition
alarm severity	Seriousness of the alarm. If the Alarm (ALM) LED is red, this indicates a major alarm. If the Alarm LED is yellow or amber, this indicates a minor alarm. If the Alarm LED is unlit, there is no alarm or the switch is halted.
chassis alarm	Preset alarm triggered by a physical condition on the switch such as a power supply failure, excessive component temperature, or media failure.
system alarm	Preset alarm triggered by a missing rescue configuration or failure to install a license for a licensed software feature. NOTE: On EX6200 switches, a system alarm can be triggered by an internal link error.

Alarm Types

The switch supports these alarms:

- Chassis alarms indicate a failure on the switch or one of its components. Chassis alarms are preset and cannot be modified.
- System alarms indicate a missing rescue configuration. System alarms are preset and cannot be modified, although you can configure them to appear automatically in the J-Web interface display or the CLI display.

Alarm Severity Levels

Alarms on switches have two severity levels:

- Major (red)—Indicates a critical situation on the switch that has resulted from one of the following conditions. A red alarm condition requires immediate action.
 - One or more hardware components have failed.
 - One or more hardware components have exceeded temperature thresholds.
 - An alarm condition configured on an interface has triggered a critical warning.
- Minor (yellow or amber)—Indicates a noncritical condition on the switch that, if left unchecked, might cause an interruption in service or degradation in performance. A yellow or amber alarm condition requires monitoring or maintenance.

A missing rescue configuration generates a yellow or amber system alarm.

SEE ALSO

| *Dashboard for EX Series Switches*

Chassis Component Alarm Conditions on EX9200 Switches

IN THIS SECTION

- [Backup Routing Engine Alarms | 304](#)

This topic describes the chassis component alarm conditions on EX9200 switches.

[Table 65 on page 298](#) lists the alarms that the chassis components can generate on EX9200 Switches.

Table 65: Chassis Component Alarm Conditions on EX9200 Switches

Chassis Component	Alarm Condition	Alarm Severity	Remedy
Air filters	Change air filter.	Minor (yellow)	Replace the air filter.
Alternative media	The switch boots from an alternate boot device, the hard disk. The CompactFlash card is typically the primary boot device. The Routing Engine boots from the hard disk when the primary boot device fails.	Minor (yellow)	Open a support case using the Case Manager link at https://www.juniper.net/support/ or call 1-888-314-5822 (toll free, US & Canada) or 1-408-745-9500 (from outside the United States).
Craft interface	The craft interface has failed.	Major (red)	Replace the failed craft interface.
Line Cards	A line card is offline.	Minor (yellow)	Check the line card. Remove and reinstall the line card. If this fails, replace the failed card.

Table 65: Chassis Component Alarm Conditions on EX9200 Switches (*Continued*)

Chassis Component	Alarm Condition	Alarm Severity	Remedy
	A line card has failed.	Major (red)	Replace the failed line card.
	A line card has been removed.	Major (red)	Install a line card in the empty slot.
Modular Interface Cards (MICs)	A MIC is offline.	Minor (yellow)	Check the MIC. Remove and reinstall the MIC. If this fails, replace the failed card.
	A MIC has failed.	Major (red)	Replace the failed MIC.
	A MIC has been removed.	Major (red)	Install a MIC in the empty slot.
Fan trays	A fan tray has been removed from the chassis.	Major (red)	Install the missing fan tray.
	One fan in the chassis is not spinning or is spinning below required speed.	Major (red)	Replace the fan tray.
	A higher-cooling capacity fan tray is required when an MPC is installed on the chassis.	Minor (yellow)	Upgrade to a high-capacity fan tray.
Host subsystem	A host subsystem has been removed.	Minor (yellow)	Install a host subsystem in the empty slot.
	A host subsystem has failed.	Major (red)	Replace the failed host subsystem.

Table 65: Chassis Component Alarm Conditions on EX9200 Switches (Continued)

Chassis Component	Alarm Condition	Alarm Severity	Remedy
Hot swapping	Too many hot-swap interrupts are occurring. This message generally indicates that a hardware component that plugs into the switch's backplane from the front (generally, an FPC) is broken.	Major (red)	Replace the failed components.
Power supplies	A power supply has been removed from the chassis.	Minor (yellow)	Install a power supply in the empty slot.
	A power supply has a high temperature.	Major (red)	Replace the failed power supply or power entry module.
	A power supply input has failed.	Major (red)	Check power supply input connection.
	A power supply output has failed.	Major (red)	Check power supply output connection.
	A power supply has failed.	Major (red)	Replace the failed power supply.
	Invalid AC power supply configuration.	Major (red)	When two AC power supplies are installed, install one power supply in an odd-numbered slot and the other power supply in an even-numbered slot.
	Invalid DC power supply configuration.	Major (red)	When two DC power supplies are installed, install one power supply in an odd-numbered slot and the other power supply in an even-numbered slot.
	AC and DC power supplies are installed.	Major (red)	Do not mix AC and DC power supplies.

Table 65: Chassis Component Alarm Conditions on EX9200 Switches *(Continued)*

Chassis Component	Alarm Condition	Alarm Severity	Remedy
	Inadequate number of power supplies.	Major (red)	Install an additional power supply.
Switch Fabric Module (SF module)	An SF module has been removed.	Minor (yellow)	Install an SF module in the empty slot.
	An SF module has failed.	Major (red)	Replace the failed SF module.
Routing Engine	Excessive framing errors on console port. An excessive framing error alarm is triggered when the default framing error threshold of 20 errors per second on a serial port is exceeded. A faulty serial console port cable might be connected to the device.	Minor (yellow)	Replace the serial cable connected to the device. If the cable is replaced and no excessive framing errors are detected within 5 minutes from the last detected framing error, the alarm is cleared automatically.
	Error in reading or writing hard disk.	Minor (yellow)	Reformat the hard disk and install the bootable image. If this fails, replace the failed Routing Engine.
	Error in reading or writing CompactFlash card.	Minor (yellow)	Reformat the CompactFlash card and install the bootable image. If this fails, replace the failed Routing Engine.
	System booted from the default backup Routing Engine. If you manually switched primary role, ignore this alarm condition.	Minor (yellow)	Install the bootable image on the default primary Routing Engine. If this fails, replace the failed Routing Engine.

Table 65: Chassis Component Alarm Conditions on EX9200 Switches (Continued)

Chassis Component	Alarm Condition	Alarm Severity	Remedy
	System booted from hard disk.	Minor (yellow)	Install the bootable image on the CompactFlash card. If this fails, replace failed the Routing Engine.
	CompactFlash card missing in boot list.	Major (red)	Replace the failed Routing Engine.
	Hard disk missing in boot list.	Major (red)	Replace the failed Routing Engine.
	Routing Engine failed to boot.	Major (red)	Replace the failed Routing Engine.
	The Ethernet management interface (fxp0 or em0) on the Routing Engine is down.	Major (red)	<ul style="list-style-type: none"> • Check the interface cable connection. • Reboot the system. • If the alarm recurs, open a support case using the Case Manager link at https://www.juniper.net/support/ or call 1-888-314-5822 (toll free, US & Canada) or 1-408-745-9500 (from outside the United States).
	/var partition usage is high.	Minor (yellow)	Clean up the system file storage space on the switch. For more information, see Freeing Up System Storage Space .
	/var partition is full.	Major (red)	Clean up the system file storage space on the switch. For more information, see Freeing Up System Storage Space .
	Rescue configuration is not set.	Minor (yellow)	Use the request system configuration rescue save command to set the rescue configuration.

Table 65: Chassis Component Alarm Conditions on EX9200 Switches (Continued)

Chassis Component	Alarm Condition	Alarm Severity	Remedy
	Feature usage requires a license or the license for the feature usage has expired.	Minor (yellow)	Install the required license for the feature specified in the alarm. For more information, see Understanding Software Licenses for EX Series Switches .
Temperature	The chassis temperature has exceeded 131° F (55° C), the fans have been turned on to full speed, and one or more fans have failed.	Minor (yellow)	<ul style="list-style-type: none"> • Check room temperature. • Check air filter and replace it, if required. • Check airflow. • Replace the fan tray.
	The chassis temperature has exceeded 149° F (65° C), and the fans have been turned on to full speed.	Minor (yellow)	<ul style="list-style-type: none"> • Check room temperature. • Check air filter and replace it, if required. • Check airflow. • Check the fans.
	The chassis temperature has exceeded 149° F (65° C), and a fan has failed. If this condition persists for more than four minutes, the switch shuts down.	Major (red)	<ul style="list-style-type: none"> • Check room temperature. • Check air filter and replace it, if required. • Check airflow. • Check the fan.

Table 65: Chassis Component Alarm Conditions on EX9200 Switches (*Continued*)

Chassis Component	Alarm Condition	Alarm Severity	Remedy
	Chassis temperature has exceeded 167° F (75° C). If this condition persists for more than four minutes, the switch shuts down.	Major (red)	<ul style="list-style-type: none"> • Check room temperature. • Check air filter and replace it, if required. • Check airflow. • Check fan.
	The temperature sensor has failed.	Major (red)	Open a support case using the Case Manager link at https://www.juniper.net/support/ or call 1-888-314-5822 (toll free, US & Canada) or 1-408-745-9500 (from outside the United States).

Backup Routing Engine Alarms

For switches with primary and backup Routing Engines, a primary Routing Engine can generate alarms for events that occur on a backup Routing Engine. [Table 66 on page 305](#) lists chassis alarms generated for events that occur on a backup Routing Engine.

NOTE: Because the failure occurs on the backup Routing Engine, alarm severity for some events (such as Ethernet interface failures) is yellow instead of red.

NOTE: For information about configuring redundant Routing Engines, see the [Junos OS High Availability Library for Routing Devices](#).

Table 66: Backup Routing Engine Alarms

Chassis Component	Alarm Condition	Alarm Severity	Remedy
Alternative media	The backup Routing Engine boots from an alternate boot device, the hard disk. The CompactFlash card is typically the primary boot device. The Routing Engine boots from the hard disk when the primary boot device fails.	Minor (yellow)	Open a support case using the Case Manager link at https://www.juniper.net/support/ or call 1-888-314-5822 (toll free, US & Canada) or 1-408-745-9500 (from outside the United States).
Boot Device	The boot device (CompactFlash or hard disk) is missing in boot list on the backup Routing Engine.	Major (red)	Replace the failed backup Routing Engine.
Ethernet	The Ethernet management interface (fxp0 or em0) on the backup Routing Engine is down.	Minor (yellow)	<ul style="list-style-type: none"> • Check the interface cable connection. • Reboot the system. • If the alarm recurs, open a support case using the Case Manager link at https://www.juniper.net/support/ or call 1-888-314-5822 (toll free, US & Canada) or 1-408-745-9500 (from outside the United States).
FRU Offline	The backup Routing Engine has stopped communicating with the primary Routing Engine.	Minor (yellow)	Open a support case using the Case Manager link at https://www.juniper.net/support/ or call 1-888-314-5822 (toll free, US & Canada) or 1-408-745-9500 (from outside the United States).
Hard Disk	Error in reading or writing hard disk on the backup Routing Engine.	Minor (yellow)	Reformat hard disk and install bootable image. If this fails, replace failed backup Routing Engine.

Table 66: Backup Routing Engine Alarms (Continued)

Chassis Component	Alarm Condition	Alarm Severity	Remedy
Multibit Memory ECC	The backup Routing Engine reports a multibit ECC error.	Minor (yellow)	<ul style="list-style-type: none"> Reboot the system with the board reset button on the backup Routing Engine. If the alarm recurs, open a support case using the Case Manager link at https://www.juniper.net/support/ or call 1-888-314-5822 (toll free, US & Canada) or 1-408-745-9500 (from outside the United States).

SEE ALSO

Craft Interface in an EX9200 Switch

Understand Alarm Types and Severity Levels on EX Series Switches

Monitor System Log Messages

IN THIS SECTION

- Purpose | 306
- Action | 307
- Meaning | 310

Purpose

NOTE: This topic applies only to the J-Web Application package.

Use the monitoring functionality to filter and view system log messages for EX Series switches.

Action

To view events in the J-Web interface, select **Monitor > Events and Alarms > View Events**.

Apply a filter or a combination of filters to view messages. You can use filters to display relevant events. [Table 67 on page 307](#) describes the different filters, their functions, and the associated actions.

To view events in the CLI, enter the following command:

```
show log
```

Table 67: Filtering System Log Messages

Field	Function	Your Action
System Log File	Specifies the name of a system log file for which you want to display the recorded events.	To specify events recorded in a particular file, select the system log filename from the list— for example, messages .
	Lists the names of all the system log files that you configure.	Select Include archived files to include archived files in the search.
	By default, a log file, <code>messages</code> , is included in the <code>/var/log/</code> directory.	
Process	Specifies the name of the process generating the events you want to display.	To specify events generated by a process, type the name of the process.
	To view all the processes running on your system, enter the CLI command <code>show system processes</code> .	For example, type <code>mgd</code> to list all messages generated by the management process.
	For more information about processes, see the Junos OS Installation and Upgrade Guide .	

Table 67: Filtering System Log Messages (Continued)

Field	Function	Your Action
Date From To	<p>Specifies the time period in which the events you want displayed are generated.</p> <p>Displays a calendar that allows you to select the year, month, day, and time. It also allows you to select the local time.</p> <p>By default, the messages generated during the last one hour are displayed. End Time shows the current time and Start Time shows the time one hour before End Time.</p>	<p>To specify the time period:</p> <ul style="list-style-type: none"> Click the Calendar icon and select the year, month, and date— for example, 02/10/2007. Click the Calendar icon and select the year, month, and date— for example, 02/10/2007. Click to select the time in hours, minutes, and seconds.
Event ID	<p>Specifies the event ID for which you want to display the messages.</p> <p>Allows you to type part of the ID and completes the remainder automatically.</p> <p>An event ID, also known as a system log message code, uniquely identifies a system log message. It begins with a prefix that indicates the generating software process or library.</p>	<p>To specify events with a specific ID, type the partial or complete ID— for example, TFTPD_AF_ERR.</p>
Description	<p>Specifies text from the description of events that you want to display.</p> <p>Allows you to use regular expressions to match text from the event description.</p> <p>NOTE: Regular expression matching is case-sensitive.</p>	<p>To specify events with a specific description, type a text string from the description with regular expression.</p> <p>For example, type ^Initial* to display all messages with lines beginning with the term <i>Initial</i>.</p>
Search	<p>Applies the specified filter and displays the matching messages.</p>	<p>To apply the filter and display messages, click Search.</p>
Reset	<p>Resets all the fields in the Events Filter box.</p>	<p>To reset the field values that are listed in the Events Filter box, click Reset.</p>

Table 67: Filtering System Log Messages (Continued)

Field	Function	Your Action
<p>Generate Raw Report</p> <p>NOTE:</p> <ul style="list-style-type: none"> Starting in Junos OS Release 14.1X53, a Raw Report can be generated from the log messages being loaded in the Events Detail table. The Generate Raw Report button is enabled after the event log messages start loading in the Events Detail table. After the log messages are completely loaded in the Events Detail table, Generate Raw Report changes to Generate Report. 	<p>Generates a list of event log messages in nontabular format.</p>	<p>To generate a raw report:</p> <ol style="list-style-type: none"> Click Generate Raw Report. <p>The <i>Opening filteredEvents.html</i> window appears.</p> <ol style="list-style-type: none"> Select Open with to open the HTML file or select Save File to save the file. Click OK.

Table 67: Filtering System Log Messages (Continued)

Field	Function	Your Action
Generate Report NOTE: Starting in Junos OS Release 14.1X53, a Formatted Report can be generated from event log messages being loaded in an Events Detail table. The Generate Report button appears only after event log messages are completely loaded in the Events Detail table. The Generate Raw Report button is displayed while event log messages are being loaded.	Generates a list of event log messages in tabular format, which shows system details, events filter criteria, and event details.	To generate a formatted report: <ol style="list-style-type: none"> 1. Click Generate Report. The <i>Opening Report.html</i> window appears. 2. Select Open with to open the HTML file or select Save File to save the file. 3. Click OK.

Meaning

Table 68 on page 311 describes the Event Summary fields.

NOTE: By default, the View Events page in the J-Web interface displays the most recent 25 events, with severity levels highlighted in different colors. After you specify the filters, Event Summary displays the events matching the specified filters. Click the **First**, **Next**, **Prev**, and **Last** links to navigate through messages.

Table 68: Viewing System Log Messages

Field	Function	Additional Information
Process	Displays the name and ID of the process that generated the system log message.	The information displayed in this field is different for messages generated on the local Routing Engine than for messages generated on another Routing Engine (on a system with two Routing Engines installed and operational). Messages from the other Routing Engine also include the identifiers re0 and re1 that identify the Routing Engine.
Severity	<p>Severity level of a message is indicated by different colors.</p> <ul style="list-style-type: none"> ● Unknown—Gray—Indicates no severity level is specified. ● Debug/Info/Notice—Green—Indicates conditions that are not errors but are of interest or might warrant special handling. ● Warning—Yellow or Amber—Indicates conditions that warrant monitoring. ● Error—Blue—Indicates standard error conditions that generally have less serious consequences than errors in the emergency, alert, and critical levels. ● Critical—Pink—Indicates critical conditions, such as hard-drive errors. ● Alert—Orange—Indicates conditions that require immediate correction, such as a corrupted system database. ● Emergency—Red—Indicates system panic or other conditions that cause the switch to stop functioning. 	<p>A severity level indicates how seriously the triggering event affects switch functions. When you configure a location for logging a facility, you also specify a severity level for the facility. Only messages from the facility that are rated at that level or higher are logged to the specified file.</p>

Table 68: Viewing System Log Messages (Continued)

Field	Function	Additional Information
Event ID	<p>Displays a code that uniquely identifies the message.</p> <p>The prefix on each code identifies the message source, and the rest of the code indicates the specific event or error.</p>	<p>The event ID begins with a prefix that indicates the generating software process.</p> <p>Some processes on a switch do not use codes. This field might be blank in a message generated from such a process.</p> <p>An event can belong to one of the following type categories:</p> <ul style="list-style-type: none"> • Error—Indicates an error or failure condition that might require corrective action. • Event—Indicates a condition or occurrence that does not generally require corrective action.
Event Description	Displays a more detailed explanation of the message.	
Time	Displays the time at which the message was logged.	

SEE ALSO

Check Active Alarms with the J-Web Interface

Understand Alarm Types and Severity Levels on EX Series Switches

Troubleshoot Temperature Alarms in EX Series Switches

IN THIS SECTION

- Problem | 313
- Cause | 313
- Solution | 313

Problem

Description

EX Series switches trigger a temperature alarm `FPC 0 EX-PFE1 Temp Too Hot` when the switch temperature becomes too hot.

Cause

Temperature sensors in the chassis monitor the temperature of the chassis. The switch triggers an alarm if a fan fails or if the temperature of the chassis exceeds permissible levels for some other reason.

Solution

When the switch triggers a temperature alarm such as the `FPC 0 EX-PFE1 Temp Too Hot` alarm, use the `show chassis environment` and the `show chassis temperature-thresholds` commands to identify the condition that triggered the alarm.



CAUTION: To prevent the switch from overheating, operate it in an area with an ambient temperature within the recommended range. To prevent airflow restriction, allow at least 6 inches (15.2 cm) of clearance around the ventilation openings.

1. Connect to the switch by using Telnet, and issue the `show chassis environment` command. This command displays environmental information about the switch chassis, including the temperature. The command also displays information about the fans, power supplies, and Routing Engines. Following is a sample output on an EX9208 switch. The output is similar on other EX Series switches.

show chassis environment (EX9208 Switch)

```
user@switch> show chassis environment
```

Class	Item	Status	Measurement
Temp	PEM 0	OK	40 degrees C / 104 degrees F
	PEM 1	OK	40 degrees C / 104 degrees F
	PEM 2	Absent	
	PEM 3	Absent	
	Routing Engine 0	OK	37 degrees C / 98 degrees F
	Routing Engine 0 CPU	OK	35 degrees C / 95 degrees F
	Routing Engine 1	Absent	
	Routing Engine 1 CPU	Absent	
	CB 0 Intake	OK	36 degrees C / 96 degrees F
	CB 0 Exhaust A	OK	34 degrees C / 93 degrees F
	CB 0 Exhaust B	OK	40 degrees C / 104 degrees F
	CB 0 ACBC	OK	39 degrees C / 102 degrees F
	CB 0 XF A	OK	46 degrees C / 114 degrees F
	CB 0 XF B	OK	45 degrees C / 113 degrees F
	CB 1 Intake	Absent	
	CB 1 Exhaust A	Absent	
	CB 1 Exhaust B	Absent	
	CB 1 ACBC	Absent	
	CB 1 XF A	Absent	
	CB 1 XF B	Absent	
	FPC 3 Intake	OK	48 degrees C / 118 degrees F
	FPC 3 Exhaust A	OK	46 degrees C / 114 degrees F
	FPC 3 Exhaust B	OK	51 degrees C / 123 degrees F
	FPC 3 XL TSen	OK	67 degrees C / 152 degrees F
	FPC 3 XL Chip	OK	58 degrees C / 136 degrees F
	FPC 3 XL_XR0 TSen	OK	67 degrees C / 152 degrees F
	FPC 3 XL_XR0 Chip	OK	51 degrees C / 123 degrees F
	FPC 3 XL_XR1 TSen	OK	67 degrees C / 152 degrees F
	FPC 3 XL_XR1 Chip	OK	63 degrees C / 145 degrees F
	FPC 3 XQ TSen	OK	67 degrees C / 152 degrees F
	FPC 3 XQ Chip	OK	63 degrees C / 145 degrees F
	FPC 3 XQ_XR0 TSen	OK	67 degrees C / 152 degrees F
	FPC 3 XQ_XR0 Chip	OK	68 degrees C / 154 degrees F
	FPC 3 XM TSen	OK	67 degrees C / 152 degrees F
	FPC 3 XM Chip	OK	76 degrees C / 168 degrees F
	FPC 3 XF TSen	OK	67 degrees C / 152 degrees F
	FPC 3 XF Chip	OK	75 degrees C / 167 degrees F

FPC 3 PLX PCIe Switch TSe	OK	51 degrees C / 123 degrees F
FPC 3 PLX PCIe Switch Chi	OK	54 degrees C / 129 degrees F
FPC 3 Aloha FPGA 0 TSen	OK	51 degrees C / 123 degrees F
FPC 3 Aloha FPGA 0 Chip	OK	70 degrees C / 158 degrees F
FPC 3 Aloha FPGA 1 TSen	OK	51 degrees C / 123 degrees F
FPC 3 Aloha FPGA 1 Chip	OK	75 degrees C / 167 degrees F
FPC 5 Intake	Testing	
FPC 5 Exhaust A	Testing	
FPC 5 Exhaust B	Testing	
Fans Top Rear Fan	OK	Spinning at intermediate-speed
Bottom Rear Fan	OK	Spinning at intermediate-speed
Top Middle Fan	OK	Spinning at intermediate-speed
Bottom Middle Fan	OK	Spinning at intermediate-speed
Top Front Fan	OK	Spinning at intermediate-speed
Bottom Front Fan	OK	Spinning at intermediate-speed

Table 69 on page 315 lists the output fields for the `show chassis environment` command. The table lists output fields in the approximate order in which they appear.

Table 69: show chassis environment Output Fields

Field Name	Field Description
Class	<p>Information about the category or class of chassis component:</p> <ul style="list-style-type: none"> Temp: Temperature of air flowing through the chassis in degrees Celsius (°C) and degrees Fahrenheit (°F) Fans: Information about the status of fans and blowers
Item	<p>Information about the chassis components:</p> <ul style="list-style-type: none"> Flexible PIC Concentrators (FPCs)—that is, the line cards Control Boards (CBs) Routing Engines Power entry modules (PEMs)—that is, the power supplies

Table 69: show chassis environment Output Fields (Continued)

Field Name	Field Description
Status	<p>Status of the specified chassis component. For example, if Class is Fans, the fan status can be:</p> <ul style="list-style-type: none"> • OK: The fans are operational. • Testing: The fans are being tested during initial power-on. • Failed: The fans have failed or the fans are not spinning. • Absent: The fan tray is not installed.
Measurement	<p>Depends on the Class. For example, if Class is Temp, indicates the temperature in degrees Celsius (°C) and degrees Fahrenheit (°F). If the Class is Fans, indicates actual fan RPM.</p>

2. Issue the command `show chassis temperature-thresholds`. This command displays the chassis temperature threshold settings. The following is a sample output on an EX9208 switch. The output is similar on other EX Series switches.

show chassis temperature-thresholds (EX9208 Switch)

```

user@ host> show chassis temperature-thresholds

```

Item	Fan speed (degrees C)		Yellow alarm (degrees C)		Red alarm (degrees C)		Fire Shutdown (degrees C)
	Normal	High	Normal	Bad fan	Normal	Bad fan	Normal
Chassis default	48	54	65	55	80	65	100
Routing Engine 0	70	80	95	95	110	110	112
FPC 3	55	60	75	65	105	80	110
FPC 5	55	60	75	65	90	80	95

Table 70 on page 317 lists the output fields for the `show chassis temperature-thresholds` command. The table lists output fields in the approximate order in which they appear.

Table 70: show chassis temperature-thresholds Output Fields

Field Name	Field Description
Item	Chassis component. You can configure the threshold information for components such as the chassis, the Routing Engines, and FPC for each slot in each FRU to display in the output. By default, information is displayed only for the chassis and the Routing Engines.
Fan speed	<p>Temperature thresholds, in degrees Celsius, for the fans to operate at normal and at high speed.</p> <ul style="list-style-type: none"> • Normal—The temperature threshold at which the fans operate at normal speed and when all the fans are present and functioning normally. • High—The temperature threshold at which the fans operate at high speed or when a fan has failed or is missing. <p>NOTE: An alarm is triggered when the temperature exceeds the threshold settings for a yellow, amber, or red alarm.</p>
Yellow or amber alarm	<p>Temperature threshold, in degrees Celsius, that triggers a yellow or amber alarm.</p> <ul style="list-style-type: none"> • Normal—The temperature threshold that must be exceeded on the device to trigger a yellow or amber alarm when the fans are running at full speed. • Bad fan—The temperature threshold that must be exceeded on the device to trigger a yellow or amber alarm when one or more fans have failed or are missing.
Red alarm	<p>Temperature threshold, in degrees Celsius, that triggers a red alarm.</p> <ul style="list-style-type: none"> • Normal—The temperature threshold that must be exceeded on the device to trigger a red alarm when the fans are running at full speed. • Bad fan—The temperature threshold that must be exceeded on the device to trigger a red alarm when one or more fans have failed or are missing.

Table 70: show chassis temperature-thresholds Output Fields (Continued)

Field Name	Field Description
Fire shutdown	Temperature threshold, in degrees Celsius, at which the switch shuts down in case of fire.

When a temperature alarm is triggered, you can identify the condition that triggered it by running the `show chassis environment` command to display the chassis temperature values for each component and comparing those with the temperature threshold values. You can display the temperature threshold values by running the `show chassis temperature-thresholds` command.

For example, for FPC 3:

- If the temperature of FPC 3 exceeds 55° C, the output indicates that the fans are operating at a high speed (no alarm is triggered).
- If the temperature of FPC 3 exceeds 65° C, a yellow alarm is triggered to indicate that one or more fans have failed.
- If the temperature of FPC 3 exceeds 75° C, a yellow alarm is triggered to indicate that the temperature threshold limit is exceeded.
- If the temperature of FPC 3 exceeds 80° C, a red alarm is triggered to indicate that one or more fans have failed.
- If the temperature of FPC 3 exceeds 105° C, a red alarm is triggered to indicate that the temperature threshold limit is exceeded.
- If the temperature of FPC 3 exceeds 110° C, the switch is powered off.

[Table 71 on page 318](#) lists the possible causes for the switch to generate a temperature alarm. It also lists the respective remedies.

Table 71: Causes and Remedies for Temperature Alarms

Cause	Remedy
Ambient temperature is above threshold temperature.	Ensure that the ambient temperature is within the threshold temperature limit. See <i>Environmental Requirements and Specifications for EX Series Switches</i> .

Table 71: Causes and Remedies for Temperature Alarms (Continued)

Cause	Remedy
Fan module or fan tray has failed.	<p>Perform the following steps:</p> <ol style="list-style-type: none"> 1. Check the fan. 2. Replace the faulty fan module or fan tray. 3. If the above two checks show no problems, open a support case using the Case Manager link at https://www.juniper.net/support/ or call 1-888-314-5822 (toll-free within the United States and Canada) or 1-408-745-9500 (from outside the United States).
Restricted airflow through the switch due to insufficient clearance around the installed switch.	Ensure that there is sufficient clearance around the installed switch.

Change History Table

Feature support is determined by the platform and release you are using. Use [Feature Explorer](#) to determine if a feature is supported on your platform.

Release	Description
14.1X53	Starting in Junos OS Release 14.1X53, a Raw Report can be generated from the log messages being loaded in the Events Detail table.
14.1X53	Starting in Junos OS Release 14.1X53, a Formatted Report can be generated from event log messages being loaded in an Events Detail table.

7

CHAPTER

Contacting Customer Support and Returning the Chassis or Components

[Returning an EX9208 Chassis or Components](#) | 321

Returning an EX9208 Chassis or Components

IN THIS SECTION

- [Returning an EX9200 Switch or Component for Repair or Replacement | 321](#)
- [Locating the Serial Number on an EX9208 Switch or Component | 322](#)
- [Contact Customer Support to Obtain a Return Material Authorization | 329](#)
- [Packing an EX9200 Switch or Component | 330](#)

Returning an EX9200 Switch or Component for Repair or Replacement

If you need to return a switch or hardware component to Juniper Networks for repair or replacement, follow this procedure:

1. Determine the serial number of the chassis if you need to return the switch. If you need to return one or more components, determine the serial number for each component. For instructions, see *Locating the Serial Number on an EX9204 Switch or Component*, "[Locating the Serial Number on an EX9208 Switch or Component](#)" on page 322, or *Locating the Serial Number on an EX9214 Switch or Component*.
2. Obtain an RMA number from JTAC as described in *Contact Customer Support to Obtain Return Material Authorization*.

NOTE: Do not return any component to Juniper Networks unless you have first obtained an RMA number. Juniper Networks reserves the right to refuse shipments that do not have an RMA. Refused shipments are returned to the customer through collect freight.

3. Pack the switch or component for shipping as described in *Packing an EX9200 Switch or Component*.

For more information about return and repair policies, see the customer support page at <https://www.juniper.net/support/guidelines.html>.

Locating the Serial Number on an EX9208 Switch or Component

IN THIS SECTION

- [Listing the Switch and Components Details with the CLI | 322](#)
- [Locating the Serial Number ID Label on an EX9200 Switch Chassis | 325](#)
- [Locating Serial Number ID Labels on FRU Components | 326](#)

If you are returning a switch or hardware component to Juniper Networks for repair or replacement, you must locate the serial number of the switch or component. You must provide the serial number to the Juniper Networks Technical Assistance Center (JTAC) when you contact them to obtain Return Materials Authorization (RMA). See *Contact Customer Support to Obtain Return Material Authorization*.

If the switch is operational and you can access the command-line interface (CLI), you can list serial numbers for the switch and for some components with a CLI command. If you do not have access to the CLI or if the serial number for the component does not appear in the command output, you can locate the serial number ID label on the physical switch or component.

NOTE: If you want to find the serial number on the physical switch component, you will need to remove the component from the switch chassis, for which you must have the required parts and tools available. See [Installing and Removing EX9208 Switch Hardware Components](#).

Listing the Switch and Components Details with the CLI

To list the switch and switch components and their serial numbers, use the `show chassis hardware` CLI command:

The following output lists the switch components and serial numbers for an EX9208 switch:

```
user@switch> show chassis hardware
Hardware inventory:
Item           Version  Part number  Serial number  Description
Chassis                JN120AAEERFB  EX9208
Midplane             REV 05   710-017414  ACAX0183      EX9208-BP
FPM Board            REV 02   710-017254  CAAN4584      Front Panel Display
PEM 0                Rev 03   740-022697  QCS1229C00F  PS 1.2-1.7kW; 100-240V AC in
PEM 1                Rev 03   740-022697  QCS1229C00T  PS 1.2-1.7kW; 100-240V AC in
```

PEM 2	Rev 03	740-022697	QCS1229C06J	PS 1.2-1.7kW; 100-240V AC in
Routing Engine 0	REV 07	740-031116	9009114067	RE-S-EX9200-1800X4
Routing Engine 1	REV 07	740-031116	9009118544	RE-S-EX9200-1800X4
CB 0	REV 15	750-031391	CAAT6718	EX9200-SCBE
CB 1	REV 15	750-031391	CAAT6562	EX9200-SCBE
FPC 0	REV 10	710-013699	CAAN3523	EX9200 40x1G Copper
CPU	REV 04	711-038484	CAAL7616	MPCE PMB 2G
MIC 0	REV 15	750-028390	CAAM7850	3D 40x 1GE(LAN) RJ45
PIC 0		BUILTIN	BUILTIN	10x 1GE(LAN) RJ45
PIC 1		BUILTIN	BUILTIN	10x 1GE(LAN) RJ45
PIC 2		BUILTIN	BUILTIN	10x 1GE(LAN) RJ45
PIC 3		BUILTIN	BUILTIN	10x 1GE(LAN) RJ45
FPC 1	REV 08	710-013699	CAAK1684	EX9200-40x1G-SFP
CPU	REV 04	711-038484	CAAK7874	MPCE PMB 2G
MIC 0	REV 26	750-028392	CAAR8623	3D 20x 1GE(LAN) SFP
PIC 0		BUILTIN	BUILTIN	10x 1GE(LAN) SFP
Xcvr 0	REV 02	740-013111	C073096	SFP-T
Xcvr 1	REV 02	740-013111	C073186	SFP-T
Xcvr 2	REV 02	740-013111	C074505	SFP-T
Xcvr 3	REV 02	740-013111	A430631	SFP-T
Xcvr 4	REV 02	740-013111	C074224	SFP-T
Xcvr 5	REV 02	740-013111	C075093	SFP-T
Xcvr 6	REV 02	740-013111	C074246	SFP-T
Xcvr 7	REV 02	740-013111	C074538	SFP-T
Xcvr 8	REV 02	740-013111	C222865	SFP-T
Xcvr 9	REV 02	740-013111	C075105	SFP-T
PIC 1		BUILTIN	BUILTIN	10x 1GE(LAN) SFP
Xcvr 0	REV 02	740-013111	C070599	SFP-T
Xcvr 1	REV 02	740-013111	C074392	SFP-T
Xcvr 2	REV 02	740-013111	C071908	SFP-T
Xcvr 3	REV 02	740-013111	C075090	SFP-T
Xcvr 4	REV 02	740-013111	C070640	SFP-T
Xcvr 5	REV 02	740-013111	C074929	SFP-T
Xcvr 6	REV 02	740-013111	A430759	SFP-T
Xcvr 7	REV 02	740-013111	C074337	SFP-T
Xcvr 8	REV 02	740-013111	C075096	SFP-T
Xcvr 9	REV 02	740-013111	C074303	SFP-T
FPC 2	REV 10	710-013699	CAAM2323	EX9200-40x1G-SFP
CPU	REV 04	711-038484	CAAN4287	MPCE PMB 2G
MIC 0	REV 26	750-028392	CAAR8305	3D 20x 1GE(LAN) SFP
PIC 0		BUILTIN	BUILTIN	10x 1GE(LAN) SFP
Xcvr 0	REV 02	740-013111	A430831	SFP-T
Xcvr 1	REV 02	740-013111	C075100	SFP-T

Xcvr 2	REV 02	740-013111	C074525	SFP-T
Xcvr 3	REV 02	740-013111	C075158	SFP-T
Xcvr 4	REV 02	740-013111	C074209	SFP-T
Xcvr 5	REV 02	740-013111	C222303	SFP-T
Xcvr 6	REV 02	740-013111	C074225	SFP-T
Xcvr 7	REV 02	740-013111	A431203	SFP-T
Xcvr 8	REV 02	740-013111	C074558	SFP-T
Xcvr 9	REV 02	740-013111	A431178	SFP-T
PIC 1		BUILTIN	BUILTIN	10x 1GE(LAN) SFP
Xcvr 0	REV 02	740-013111	A430800	SFP-T
Xcvr 1	REV 02	740-013111	C074354	SFP-T
Xcvr 2	REV 02	740-013111	C073948	SFP-T
Xcvr 3	REV 02	740-013111	C071967	SFP-T
Xcvr 4	REV 02	740-013111	C074208	SFP-T
Xcvr 5	REV 02	740-013111	C074709	SFP-T
Xcvr 6	REV 02	740-013111	C073150	SFP-T
Xcvr 7	REV 02	740-013111	C075106	SFP-T
Xcvr 8	REV 02	740-013111	C073953	SFP-T
Xcvr 9	REV 01	740-013111	8512252	SFP-T
FPC 3	REV 10	750-038489	CAAM2342	EX9200-40x1G-SFP
CPU	REV 04	711-038484	CAAN4157	MPCE PMB 2G
MIC 0	REV 26	750-028392	CAAR8666	3D 20x 1GE(LAN) SFP
PIC 0		BUILTIN	BUILTIN	10x 1GE(LAN) SFP
Xcvr 0	REV 02	740-013111	C074418	SFP-T
Xcvr 1	REV 02	740-013111	A431151	SFP-T
Xcvr 2	REV 02	740-013111	C073957	SFP-T
Xcvr 3	REV 02	740-013111	C073920	SFP-T
Xcvr 4	REV 02	740-013111	A430809	SFP-T
Xcvr 5	REV 02	740-013111	C074949	SFP-T
Xcvr 6	REV 02	740-013111	C074911	SFP-T
Xcvr 7	REV 02	740-013111	C075092	SFP-T
Xcvr 8	REV 02	740-013111	C075181	SFP-T
Xcvr 9	REV 02	740-013111	C075071	SFP-T
PIC 1		BUILTIN	BUILTIN	10x 1GE(LAN) SFP
Xcvr 0	REV 02	740-013111	C075019	SFP-T
Xcvr 1	REV 02	740-013111	A434447	SFP-T
Xcvr 2	REV 02	740-013111	A430280	SFP-T
Xcvr 3	REV 02	740-013111	C070861	SFP-T
Xcvr 4	REV 02	740-013111	A430732	SFP-T
Xcvr 5	REV 02	740-013111	A431229	SFP-T
Xcvr 6	REV 02	740-013111	B388861	SFP-T
Xcvr 7	REV 02	740-013111	C222819	SFP-T
Xcvr 8	REV 02	740-013111	9332952	SFP-T

Xcvr 9	REV 02	740-013111	A430234	SFP-T
FPC 4	REV 10	710-013699	CAAM2337	EX9200-40x1G-SFP
CPU	REV 04	711-038484	CAAN4153	MPCE PMB 2G
MIC 0	REV 15	750-028390	CAAH1550	3D 40x 1GE(LAN) RJ45
PIC 0		BUILTIN	BUILTIN	10x 1GE(LAN) RJ45
PIC 1		BUILTIN	BUILTIN	10x 1GE(LAN) RJ45
PIC 2		BUILTIN	BUILTIN	10x 1GE(LAN) RJ45
PIC 3		BUILTIN	BUILTIN	10x 1GE(LAN) RJ45
FPC 5	REV 10	710-013699	CAAM2335	EX9200-40x1G-SFP
CPU	REV 04	711-038484	CAAN4293	MPCE PMB 2G
MIC 1	REV 26	750-028392	CAAR8483	3D 20x 1GE(LAN) SFP
PIC 2		BUILTIN	BUILTIN	10x 1GE(LAN) SFP
Xcvr 0	REV 02	740-013111	C074218	SFP-T
Xcvr 1	REV 02	740-013111	B041352	SFP-T
Xcvr 2	REV 02	740-013111	C074523	SFP-T
Xcvr 3	REV 02	740-013111	A431001	SFP-T
Xcvr 4	REV 02	740-013111	C074987	SFP-T
Xcvr 5	REV 02	740-013111	C222844	SFP-T
Xcvr 6	REV 02	740-013111	C074994	SFP-T
Xcvr 7	REV 02	740-013111	C074339	SFP-T
Xcvr 8	REV 02	740-013111	C222894	SFP-T
Xcvr 9	REV 01	740-013111	8511928	SFP-T
PIC 3		BUILTIN	BUILTIN	10x 1GE(LAN) SFP
Xcvr 0	REV 02	740-013111	C070239	SFP-T
Xcvr 1	REV 02	740-013111	C074438	SFP-T
Xcvr 2	REV 02	740-013111	C074276	SFP-T
Xcvr 3	REV 02	740-013111	C075173	SFP-T
Xcvr 4	REV 02	740-013111	C074262	SFP-T
Xcvr 5	REV 02	740-013111	C074536	SFP-T
Xcvr 6	REV 02	740-013111	C074546	SFP-T
Xcvr 7	REV 02	740-013111	C074573	SFP-T
Xcvr 8	REV 02	740-013111	C073158	SFP-T
Xcvr 9	REV 02	740-013111	C070783	SFP-T
Fan Tray				Enhanced Left Fan Tray

Locating the Serial Number ID Label on an EX9200 Switch Chassis

The serial number ID label is located on the side of the chassis on an EX9208 switch. See [Figure 99 on page 326](#).

Figure 99: Location of the Serial Number ID Label on EX9208 Switch Chassis

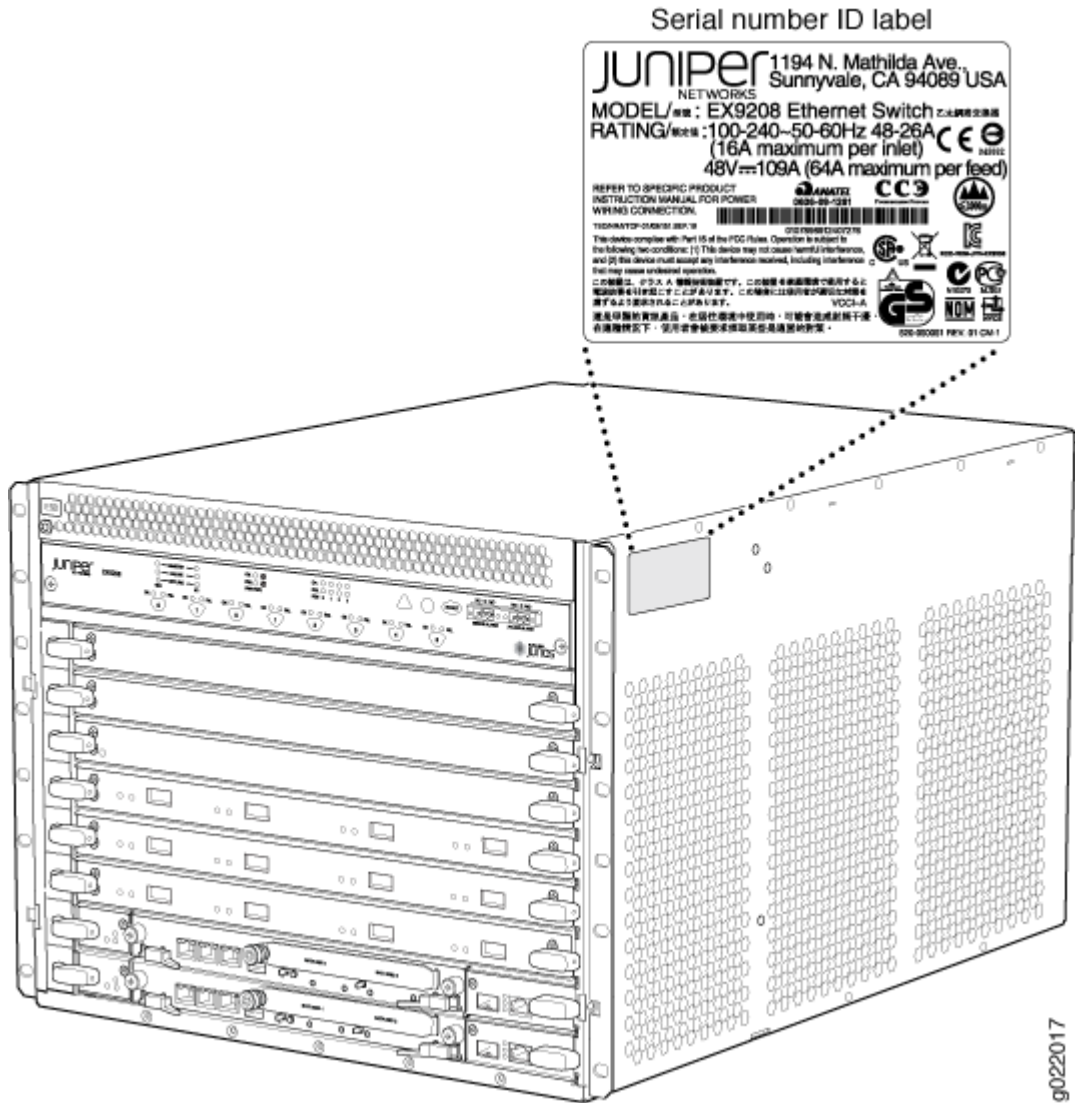

Locating Serial Number ID Labels on FRU Components

The power supplies, fan tray, Routing Engine modules (RE modules), Switch Fabric module (SF module), and line cards installed in an EX9200 switch are field-replaceable units (FRUs). For each of these FRUs, you must remove the FRU from the switch chassis to see the FRU's serial number ID label.

- AC Power supply—The serial number ID label is on the top of the AC power supply. See [Figure 100 on page 327](#). Also see "[Removing an AC Power Supply from an EX9208 Switch](#)" on page 221.

Figure 102: Location of the Serial Number ID Label on the SF Module

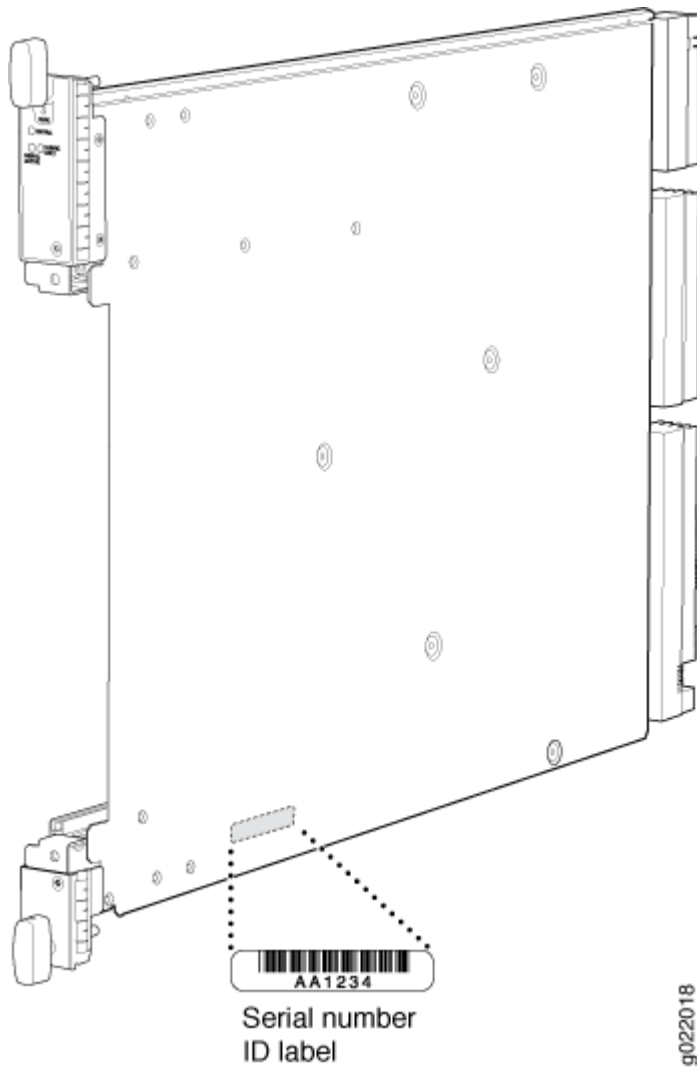

- Routing Engine module (RE module)—The serial number label is located on the left side of the top of the RE module (see [Figure 103 on page 329](#)). See *Removing an RE Module from an EX9200 Switch*.

Figure 103: Location of the Serial Number ID Label on the RE Module

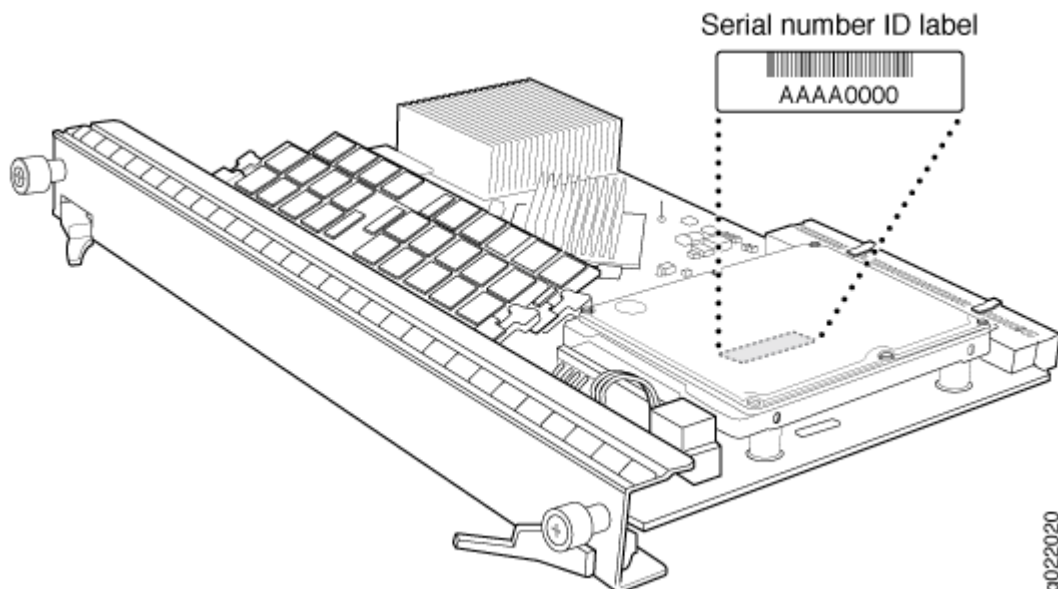

Contact Customer Support to Obtain a Return Material Authorization

If you need to return a device or hardware component to Juniper Networks for repair or replacement, obtain a Return Material Authorization (RMA) number from Juniper Networks Technical Assistance Center (JTAC). You must obtain an RMA number before you attempt to return the component.

After locating the serial number of the device or hardware component you want to return, open a service request with the Juniper Networks Technical Assistance Center (JTAC) on the Web or by telephone.

Before you request an RMA number from JTAC, be prepared to provide the following information:

- Your existing service request number, if you have one
- Serial number of the component
- Your name, organization name, telephone number, fax number, and shipping address
- Details of the failure or problem
- Type of activity being performed on the device when the problem occurred
- Configuration data displayed by one or more `show` commands

You can contact JTAC 24 hours a day, seven days a week on the Web or by telephone:

- Service Request Manager: <https://support.juniper.net/support>
- Telephone: +1-888-314-JTAC (+1-888-314-5822), toll free in U.S., Canada, and Mexico

NOTE: For international or direct-dial options in countries without toll free numbers, see <https://support.juniper.net/support>.

If you are contacting JTAC by telephone, enter your 12-digit service request number followed by the pound (#) key for an existing case, or press the star (*) key to be routed to the next available support engineer.

The support representative validates your request and issues an RMA number for return of the component.

Packing an EX9200 Switch or Component

IN THIS SECTION

- [Packing an EX9200 Switch | 331](#)
- [Packing EX9200 Switch Components for Shipping | 332](#)

If you are returning an EX9200 switch or component to Juniper Networks for repair or replacement, pack the item as described in this topic.

Before you begin packing the switch or component, ensure you have:

- Followed all the steps listed in *Contact Customer Support to Obtain Return Material Authorization*.
- Retrieved the original shipping carton and packing materials. Contact your JTAC representative if you do not have these materials, to learn about approved packing materials. See *Contact Customer Support to Obtain Return Material Authorization*.
- Ensure you understand how to prevent electrostatic discharge (ESD) damage. See *Prevention of Electrostatic Discharge Damage*.

Ensure that you have the following parts and tools available:

- An ESD wrist strap

Packing an EX9200 Switch

If you need to transport the switch to another location or return the switch to Juniper Networks, you need to pack the switch securely in its original packaging to prevent damage during transportation.

To pack the switch for shipment:

1. Retrieve the shipping crate and packing materials in which the switch was originally shipped. If you do not have these materials, contact your Juniper Networks representative about approved packaging materials.
2. On the console or other management device connected to the primary Routing Engine, enter CLI operational mode and issue the following command to shut down the switch software. (If two Routing Engine modules are installed, also issue the command on the backup Routing Engine.)

```
user@switch> request system halt
```

Wait until a message appears on the console confirming that the operating system has halted.

For more information about the command, see the [CLI Explorer](#).

3. Wrap and fasten one end of the ESD wrist strap around your bare wrist, and connect the other end of the strap to the ESD point on the switch.
4. Shut down power to the switch by pressing the AC input switch or DC circuit breaker for all power supplies to the off position.
5. Disconnect power from the switch.
6. Remove the cables that connect to all external devices.
7. Remove all field replaceable units (FRUs) from the switch.
8. Remove the switch from the rack:
 - If you are using a mechanical lift, place the lift platform under the switch, unscrew and remove the mounting screws from the rack, and move the switch to the shipping crate.
 - If you are not using a mechanical lift and the switch weight is fully supported by a shelf or another switch, unscrew and remove the mounting screws from the rack. Three people can then lift the switch and move it to the shipping crate.
 - If you are not using a mechanical lift and the switch weight is not fully supported by a shelf or another switch, three people must grasp the switch while a fourth person unscrews and removes the mounting screws from the rack. The three people can then move the switch to the shipping container.
9. Place the switch in the shipping crate or onto the pallet. If on a pallet, bolt the switch to the pallet.
10. Cover the switch with an antistatic bag and place the packing foam on top of and around the switch.
11. Replace the accessory box on top of the packing foam.

12. Securely tape the box closed or place the crate cover over the switch.
13. Write the RMA number on the exterior of the box to ensure proper tracking.

Packing EX9200 Switch Components for Shipping

Before you begin packing a switch component, ensure that you have the following parts and tools available:

- Antistatic bag, one for each component
- An ESD wrist strap

To pack EX9200 switch components, follow the instructions here.



CAUTION: Do not stack switch components. Return individual components in separate boxes if they do not fit together on one level in the shipping box.

To pack EX9200 switch components:

- Place individual components in antistatic bags.
- Use the original packing materials if they are available. If the original packing materials are not available, ensure the component is adequately packed to prevent damage during transit. The packing material you use must be able to support the weight of the component.
- Ensure that the components are adequately protected by wrapping them well with packing materials. Pack the component in an oversized box (if the original box is not available) with extra packing material around the unit so that the component is prevented from moving around inside the box.
- Securely tape the box closed.
- Write the RMA number on the exterior of the box to ensure proper tracking.



CHAPTER

Safety and Compliance Information

General Safety Guidelines and Warnings | 335

Definitions of Safety Warning Levels | 336

Qualified Personnel Warning | 338

Warning Statement for Norway and Sweden | 338

Fire Safety Requirements | 339

Installation Instructions Warning | 340

Chassis and Component Lifting Guidelines | 341

Restricted Access Warning | 341

Ramp Warning | 343

Rack-Mounting and Cabinet-Mounting Warnings | 343

Grounded Equipment Warning | 347

Radiation from Open Port Apertures Warning | 348

Laser and LED Safety Guidelines and Warnings | 349

Maintenance and Operational Safety Guidelines and Warnings | 352

General Electrical Safety Guidelines and Warnings | 358

Action to Take After an Electrical Accident | 359

Prevention of Electrostatic Discharge Damage | 360

AC Power Electrical Safety Guidelines | 361

AC Power Disconnection Warning | 362

DC Power Electrical Safety Guidelines | 363

DC Power Disconnection Warning | 364

DC Power Grounding Requirements and Warning | 366

DC Power Wiring Sequence Warning | 366

DC Power Wiring Terminations Warning | 368

Multiple Power Supplies Disconnection Warning | 369

TN Power Warning | 370

Agency Approvals for EX Series Switches | 371

Battery Compliance Statement for Environmental Requirements for EX Series Switches | 372

Compliance Statements for EMC Requirements for EX Series Switches | 373

Compliance Statements for Acoustic Noise for EX Series Switches | 377

General Safety Guidelines and Warnings

The following guidelines help ensure your safety and protect the device from damage. The list of guidelines might not address all potentially hazardous situations in your working environment, so be alert and exercise good judgment at all times.

- Perform only the procedures explicitly described in the hardware documentation for this device. Make sure that only authorized service personnel perform other system services.
- Keep the area around the device clear and free from dust before, during, and after installation.
- Keep tools away from areas where people could trip over them while walking.
- Do not wear loose clothing or jewelry, such as rings, bracelets, or chains, which could become caught in the device.
- Wear safety glasses if you are working under any conditions that could be hazardous to your eyes.
- Do not perform any actions that create a potential hazard to people or make the equipment unsafe.
- Never attempt to lift an object that is too heavy for one person to handle.
- Never install or manipulate wiring during electrical storms.
- Never install electrical jacks in wet locations unless the jacks are specifically designed for wet environments.
- Operate the device only when it is properly grounded.
- Follow the instructions in this guide to properly ground the device to earth.
- Replace fuses only with fuses of the same type and rating.
- Do not open or remove chassis covers or sheet-metal parts unless instructions are provided in the hardware documentation for this device. Such an action could cause severe electrical shock.
- Do not push or force any objects through any opening in the chassis frame. Such an action could result in electrical shock or fire.
- Avoid spilling liquid onto the chassis or onto any device component. Such an action could cause electrical shock or damage the device.
- Avoid touching uninsulated electrical wires or terminals that have not been disconnected from their power source. Such an action could cause electrical shock.

- Some parts of the chassis, including AC and DC power supply surfaces, power supply unit handles, SFB card handles, and fan tray handles might become hot. The following label provides the warning for hot surfaces on the chassis:



- Always ensure that all modules, power supplies, and cover panels are fully inserted and that the installation screws are fully tightened.

Definitions of Safety Warning Levels

The documentation uses the following levels of safety warnings (there are two *Warning* formats):

NOTE: You might find this information helpful in a particular situation, or you might overlook this important information if it was not highlighted in a Note.



CAUTION: You need to observe the specified guidelines to prevent minor injury or discomfort to you or severe damage to the device.

Attention Veillez à respecter les consignes indiquées pour éviter toute incommodité ou blessure légère, voire des dégâts graves pour l'appareil.



LASER WARNING: This symbol alerts you to the risk of personal injury from a laser.

Avertissement Ce symbole signale un risque de blessure provoquée par rayon laser.



WARNING: This symbol means danger. You are in a situation that could cause bodily injury. Before you work on any equipment, be aware of the hazards involved with electrical circuitry, and familiarize yourself with standard practices for preventing accidents.

Waarschuwing Dit waarschuwingssymbool betekent gevaar. U verkeert in een situatie die lichamelijk letsel kan veroorzaken. Voordat u aan enige apparatuur gaat werken, dient u zich bewust te zijn van de bij elektrische schakelingen betrokken risico's en dient u op de hoogte te zijn van standaard maatregelen om ongelukken te voorkomen.

Varoitus Tämä varoitusmerkki merkitsee vaaraa. Olet tilanteessa, joka voi johtaa ruumiinvammaan. Ennen kuin työskentelet minkään laitteiston parissa, ota selvää sähkökytkentöihin liittyvistä vaaroista ja tavanomaisista onnettomuuksien ehkäisykeinoista.

Avertissement Ce symbole d'avertissement indique un danger. Vous vous trouvez dans une situation pouvant causer des blessures ou des dommages corporels. Avant de travailler sur un équipement, soyez conscient des dangers posés par les circuits électriques et familiarisez-vous avec les procédures couramment utilisées pour éviter les accidents.

Warnung Dieses Warnsymbol bedeutet Gefahr. Sie befinden sich in einer Situation, die zu einer Körperverletzung führen könnte. Bevor Sie mit der Arbeit an irgendeinem Gerät beginnen, seien Sie sich der mit elektrischen Stromkreisen verbundenen Gefahren und der Standardpraktiken zur Vermeidung von Unfällen bewußt.

Avvertenza Questo simbolo di avvertenza indica un pericolo. La situazione potrebbe causare infortuni alle persone. Prima di lavorare su qualsiasi apparecchiatura, occorre conoscere i pericoli relativi ai circuiti elettrici ed essere al corrente delle pratiche standard per la prevenzione di incidenti.

Advarsel Dette varselsymbolet betyr fare. Du befinner deg i en situasjon som kan føre til personskade. Før du utfører arbeid på utstyr, må du være oppmerksom på de faremomentene som elektriske kretser innebærer, samt gjøre deg kjent med vanlig praksis når det gjelder å unngå ulykker.

Aviso Este símbolo de aviso indica perigo. Encontra-se numa situação que lhe poderá causar danos físicos. Antes de começar a trabalhar com qualquer equipamento, familiarize-se com os perigos relacionados com circuitos eléctricos, e com quaisquer práticas comuns que possam prevenir possíveis acidentes.

¡Atención! Este símbolo de aviso significa peligro. Existe riesgo para su integridad física. Antes de manipular cualquier equipo, considerar los riesgos que entraña la corriente eléctrica y familiarizarse con los procedimientos estándar de prevención de accidentes.

Varning! Denna varningssymbol signalerar fara. Du befinner dig i en situation som kan leda till personskada. Innan du utför arbete på någon utrustning måste du vara medveten om farorna med elkretsar och känna till vanligt förfarande för att förebygga skador.

Qualified Personnel Warning



WARNING: Only trained and qualified personnel should install or replace the device.

Waarschuwing Installatie en reparaties mogen uitsluitend door getraind en bevoegd personeel uitgevoerd worden.

Varoitus Ainoastaan koulutettu ja pätevä henkilökunta saa asentaa tai vaihtaa tämän laitteen.

Avertissement Tout installation ou remplacement de l'appareil doit être réalisé par du personnel qualifié et compétent.

Warnung Gerät nur von geschultem, qualifiziertem Personal installieren oder auswechseln lassen.

Avvertenza Solo personale addestrato e qualificato deve essere autorizzato ad installare o sostituire questo apparecchio.

Advarsel Kun kvalifisert personell med riktig opplæring bør montere eller bytte ut dette utstyret.

Aviso Este equipamento deverá ser instalado ou substituído apenas por pessoal devidamente treinado e qualificado.

¡Atención! Estos equipos deben ser instalados y reemplazados exclusivamente por personal técnico adecuadamente preparado y capacitado.

Warning! Denna utrustning ska endast installeras och bytas ut av utbildad och kvalificerad personal.

Warning Statement for Norway and Sweden



WARNING: The equipment must be connected to an earthed mains socket-outlet.

Advarsel Apparatet skal kobles til en jordet stikkontakt.

Warning! Apparaten skall anslutas till jordat nätuttag.

Fire Safety Requirements

IN THIS SECTION

- [Fire Suppression | 339](#)
- [Fire Suppression Equipment | 339](#)

In the event of a fire emergency, the safety of people is the primary concern. You should establish procedures for protecting people in the event of a fire emergency, provide safety training, and properly provision fire-control equipment and fire extinguishers.

In addition, you should establish procedures to protect your equipment in the event of a fire emergency. Juniper Networks products should be installed in an environment suitable for electronic equipment. We recommend that fire suppression equipment be available in the event of a fire in the vicinity of the equipment and that all local fire, safety, and electrical codes and ordinances be observed when you install and operate your equipment.

Fire Suppression

In the event of an electrical hazard or an electrical fire, you should first turn power off to the equipment at the source. Then use a Type C fire extinguisher, which uses noncorrosive fire retardants, to extinguish the fire.

Fire Suppression Equipment

Type C fire extinguishers, which use noncorrosive fire retardants such as carbon dioxide and Halotron™, are most effective for suppressing electrical fires. Type C fire extinguishers displace oxygen from the point of combustion to eliminate the fire. For extinguishing fire on or around equipment that draws air from the environment for cooling, you should use this type of inert oxygen displacement extinguisher instead of an extinguisher that leaves residues on equipment.

Do not use multipurpose Type ABC chemical fire extinguishers (dry chemical fire extinguishers). The primary ingredient in these fire extinguishers is monoammonium phosphate, which is very sticky and

difficult to clean. In addition, in the presence of minute amounts of moisture, monoammonium phosphate can become highly corrosive and corrodes most metals.

Any equipment in a room in which a chemical fire extinguisher has been discharged is subject to premature failure and unreliable operation. The equipment is considered to be irreparably damaged.

NOTE: To keep warranties effective, do not use a dry chemical fire extinguisher to control a fire at or near a Juniper Networks device. If a dry chemical fire extinguisher is used, the unit is no longer eligible for coverage under a service agreement.

We recommend that you dispose of any irreparably damaged equipment in an environmentally responsible manner.

Installation Instructions Warning



WARNING: Read the installation instructions before you connect the device to a power source.

Waarschuwing Raadpleeg de installatie-aanwijzingen voordat u het systeem met de voeding verbindt.

Varoitus Lue asennusohjeet ennen järjestelmän yhdistämistä virtälähteeseen.

Avertissement Avant de brancher le système sur la source d'alimentation, consulter les directives d'installation.

Warnung Lesen Sie die Installationsanweisungen, bevor Sie das System an die Stromquelle anschließen.

Avvertenza Consultare le istruzioni di installazione prima di collegare il sistema all'alimentatore.

Advarsel Les installasjonsinstruksjonene før systemet kobles til strømkilden.

Aviso Leia as instruções de instalação antes de ligar o sistema à sua fonte de energia.

¡Atención! Ver las instrucciones de instalación antes de conectar el sistema a la red de alimentación.

Varning! Läs installationsanvisningarna innan du kopplar systemet till dess strömförsörjningsenhet.

Chassis and Component Lifting Guidelines

- Before moving the device to a site, ensure that the site meets the power, environmental, and clearance requirements.
- Before lifting or moving the device, disconnect all external cables and wires.
- As when lifting any heavy object, ensure that your legs bear most of the weight rather than your back. Keep your knees bent and your back relatively straight. Do not twist your body as you lift. Balance the load evenly and be sure that your footing is firm.
- Use the following lifting guidelines to lift devices and components:
 - Up to 39.7 lb (18 kg): One person.
 - From 39.7 lb (18 kg) to 70.5 lb (32 kg): Two or more people.
 - From 70.5 lb (32 kg) to 121.2 lb (55 kg): Three or more people.
 - Above 121.2 lb (55 kg): Use material handling systems (such as levers, slings, lifts, and so on). When this is not practical, engage specially trained persons or systems (such as riggers or movers).

Restricted Access Warning



WARNING: This unit is intended for installation in restricted access areas. A restricted access area is an area to which access can be gained only by service personnel through the use of a special tool, lock and key, or other means of security, and which is controlled by the authority responsible for the location.

Waarschuwing Dit toestel is bedoeld voor installatie op plaatsen met beperkte toegang. Een plaats met beperkte toegang is een plaats waar toegang slechts door servicepersoneel verkregen kan worden door middel van een speciaal instrument, een slot en sleutel, of een ander veiligheidsmiddel, en welke beheerd wordt door de overheidsinstantie die verantwoordelijk is voor de locatie.

Varoitus Tämä laite on tarkoitettu asennettavaksi paikkaan, johon pääsy on rajoitettua. Paikka, johon pääsy on rajoitettua, tarkoittaa paikkaa, johon vain huoltohenkilöstö pääsee jonkin erikoistyökalun, lukkoon sopivan avaimen tai jonkin muun turvalaitteen avulla ja joka on paikasta vastuussa olevien toimivaltaisten henkilöiden valvoma.

Avertissement Cet appareil est à installer dans des zones d'accès réservé. Ces dernières sont des zones auxquelles seul le personnel de service peut accéder en utilisant un outil spécial, un mécanisme de verrouillage et une clé, ou tout autre moyen de sécurité. L'accès aux zones de sécurité est sous le contrôle de l'autorité responsable de l'emplacement.

Warnung Diese Einheit ist zur Installation in Bereichen mit beschränktem Zutritt vorgesehen. Ein Bereich mit beschränktem Zutritt ist ein Bereich, zu dem nur Wartungspersonal mit einem Spezialwerkzeugs, Schloß und Schlüssel oder anderer Sicherheitsvorkehrungen Zugang hat, und der von dem für die Anlage zuständigen Gremium kontrolliert wird.

Avvertenza Questa unità deve essere installata in un'area ad accesso limitato. Un'area ad accesso limitato è un'area accessibile solo a personale di assistenza tramite un'attrezzo speciale, lucchetto, o altri dispositivi di sicurezza, ed è controllata dall'autorità responsabile della zona.

Advarsel Denne enheten er laget for installasjon i områder med begrenset adgang. Et område med begrenset adgang gir kun adgang til servicepersonale som bruker et spesielt verktøy, lås og nøkkel, eller en annen sikkerhetsanordning, og det kontrolleres av den autoriteten som er ansvarlig for området.

Aviso Esta unidade foi concebida para instalação em áreas de acesso restrito. Uma área de acesso restrito é uma área à qual apenas tem acesso o pessoal de serviço autorizado, que possua uma ferramenta, chave e fechadura especial, ou qualquer outra forma de segurança. Esta área é controlada pela autoridade responsável pelo local.

¡Atención! Esta unidad ha sido diseñada para instalarse en áreas de acceso restringido. Área de acceso restringido significa un área a la que solamente tiene acceso el personal de servicio mediante la utilización de una herramienta especial, cerradura con llave, o algún otro medio de seguridad, y que está bajo el control de la autoridad responsable del local.

Warning! Denna enhet är avsedd för installation i områden med begränsat tillträde. Ett område med begränsat tillträde får endast tillträdas av servicepersonal med ett speciellt verktyg, lås och nyckel, eller annan säkerhetsanordning, och kontrolleras av den auktoritet som ansvarar för området.

Ramp Warning



WARNING: When installing the device, do not use a ramp inclined at more than 10 degrees.

Waarschuwing Gebruik een oprijplaat niet onder een hoek van meer dan 10 graden.

Varoitus Älä käytä sellaista kaltevaa pintaa, jonka kaltevuus ylittää 10 astetta.

Avertissement Ne pas utiliser une rampe dont l'inclinaison est supérieure à 10 degrés.

Warnung Keine Rampen mit einer Neigung von mehr als 10 Grad verwenden.

Avvertenza Non usare una rampa con pendenza superiore a 10 gradi.

Advarsel Bruk aldri en rampe som heller mer enn 10 grader.

Aviso Não utilize uma rampa com uma inclinação superior a 10 graus.

¡Atención! No usar una rampa inclinada más de 10 grados.

Varning! Använd inte ramp med en lutning på mer än 10 grader.

Rack-Mounting and Cabinet-Mounting Warnings

Ensure that the rack or cabinet in which the device is installed is evenly and securely supported. Uneven mechanical loading could lead to a hazardous condition.



WARNING: To prevent bodily injury when mounting or servicing the device in a rack, take the following precautions to ensure that the system remains stable. The following directives help maintain your safety:

- Install the device in a rack that is secured to the building structure.
- Mount the device at the bottom of the rack if it is the only unit in the rack.
- When mounting the device on a partially filled rack, load the rack from the bottom to the top, with the heaviest component at the bottom of the rack.

- If the rack is provided with stabilizing equipment, install the stabilizers before mounting or servicing the device in the rack.

Waarschuwing Om lichamelijk letsel te voorkomen wanneer u dit toestel in een rek monteert of het daar een servicebeurt geeft, moet u speciale voorzorgsmaatregelen nemen om ervoor te zorgen dat het toestel stabiel blijft. De onderstaande richtlijnen worden verstrekt om uw veiligheid te verzekeren:

- De Juniper Networks switch moet in een stellage worden geïnstalleerd die aan een bouwsel is verankerd.
- Dit toestel dient onderaan in het rek gemonteerd te worden als het toestel het enige in het rek is.
- Wanneer u dit toestel in een gedeeltelijk gevuld rek monteert, dient u het rek van onderen naar boven te laden met het zwaarste onderdeel onderaan in het rek.
- Als het rek voorzien is van stabiliseringshulpmiddelen, dient u de stabilisatoren te monteren voordat u het toestel in het rek monteert of het daar een servicebeurt geeft.

Varoitus Kun laite asetetaan telineeseen tai huolletaan sen ollessa telineessä, on noudatettava erityisiä varotoimia järjestelmän vakavuuden säilyttämiseksi, jotta vältetään loukkaantumiselta. Noudata seuraavia turvallisuusohjeita:

- Juniper Networks switch on asennettava telineeseen, joka on kiinnitetty rakennukseen.
- Jos telineessä ei ole muita laitteita, aseta laite telineen alaosaan.
- Jos laite asetetaan osaksi täytettyyn telineeseen, aloita kuormittaminen sen alaosasta kaikkein raskaimmalla esineellä ja siirry sitten sen yläosaan.
- Jos telinettä varten on vakaimet, asenna ne ennen laitteen asettamista telineeseen tai sen huoltamista siinä.

Avertissement Pour éviter toute blessure corporelle pendant les opérations de montage ou de réparation de cette unité en casier, il convient de prendre des précautions spéciales afin de maintenir la stabilité du système. Les directives ci-dessous sont destinées à assurer la protection du personnel:

- Le rack sur lequel est monté le Juniper Networks switch doit être fixé à la structure du bâtiment.

- Si cette unité constitue la seule unité montée en casier, elle doit être placée dans le bas.
- Si cette unité est montée dans un casier partiellement rempli, charger le casier de bas en haut en plaçant l'élément le plus lourd dans le bas.
- Si le casier est équipé de dispositifs stabilisateurs, installer les stabilisateurs avant de monter ou de réparer l'unité en casier.

Warnung Zur Vermeidung von Körperverletzung beim Anbringen oder Warten dieser Einheit in einem Gestell müssen Sie besondere Vorkehrungen treffen, um sicherzustellen, daß das System stabil bleibt. Die folgenden Richtlinien sollen zur Gewährleistung Ihrer Sicherheit dienen:

- Der Juniper Networks switch muß in einem Gestell installiert werden, das in der Gebäudestruktur verankert ist.
- Wenn diese Einheit die einzige im Gestell ist, sollte sie unten im Gestell angebracht werden.
- Bei Anbringung dieser Einheit in einem zum Teil gefüllten Gestell ist das Gestell von unten nach oben zu laden, wobei das schwerste Bauteil unten im Gestell anzubringen ist.
- Wird das Gestell mit Stabilisierungszubehör geliefert, sind zuerst die Stabilisatoren zu installieren, bevor Sie die Einheit im Gestell anbringen oder sie warten.

Avvertenza Per evitare infortuni fisici durante il montaggio o la manutenzione di questa unità in un supporto, occorre osservare speciali precauzioni per garantire che il sistema rimanga stabile. Le seguenti direttive vengono fornite per garantire la sicurezza personale:

- Il Juniper Networks switch deve essere installato in un telaio, il quale deve essere fissato alla struttura dell'edificio.
- Questa unità deve venire montata sul fondo del supporto, se si tratta dell'unica unità da montare nel supporto.
- Quando questa unità viene montata in un supporto parzialmente pieno, caricare il supporto dal basso all'alto, con il componente più pesante sistemato sul fondo del supporto.
- Se il supporto è dotato di dispositivi stabilizzanti, installare tali dispositivi prima di montare o di procedere alla manutenzione dell'unità nel supporto.

Advarsel Unngå fysiske skader under montering eller reparasjonsarbeid på denne enheten når den befinner seg i et kabinett. Vær nøye med at systemet er stabilt. Følgende retningslinjer er gitt for å verne om sikkerheten:

- Juniper Networks switch må installeres i et stativ som er forankret til bygningsstrukturen.
- Denne enheten bør monteres nederst i kabinettet hvis dette er den eneste enheten i kabinettet.
- Ved montering av denne enheten i et kabinett som er delvis fylt, skal kabinettet lastes fra bunnen og opp med den tyngste komponenten nederst i kabinettet.
- Hvis kabinettet er utstyrt med stabiliseringsutstyr, skal stabilisatorene installeres før montering eller utføring av reparasjonsarbeid på enheten i kabinettet.

Aviso Para se prevenir contra danos corporais ao montar ou reparar esta unidade numa estante, deverá tomar precauções especiais para se certificar de que o sistema possui um suporte estável. As seguintes directrizes ajudá-lo-ão a efectuar o seu trabalho com segurança:

- O Juniper Networks switch deverá ser instalado numa prateleira fixa à estrutura do edifício.
- Esta unidade deverá ser montada na parte inferior da estante, caso seja esta a única unidade a ser montada.
- Ao montar esta unidade numa estante parcialmente ocupada, coloque os itens mais pesados na parte inferior da estante, arrumando-os de baixo para cima.
- Se a estante possuir um dispositivo de estabilização, instale-o antes de montar ou reparar a unidade.

¡Atención! Para evitar lesiones durante el montaje de este equipo sobre un bastidor, oerriormente durante su mantenimiento, se debe poner mucho cuidado en que el sistema quede bien estable. Para garantizar su seguridad, proceda según las siguientes instrucciones:

- El Juniper Networks switch debe instalarse en un bastidor fijado a la estructura del edificio.
- Colocar el equipo en la parte inferior del bastidor, cuando sea la única unidad en el mismo.

- Cuando este equipo se vaya a instalar en un bastidor parcialmente ocupado, comenzar la instalación desde la parte inferior hacia la superior colocando el equipo más pesado en la parte inferior.
- Si el bastidor dispone de dispositivos estabilizadores, instalar éstos antes de montar o proceder al mantenimiento del equipo instalado en el bastidor.

Warning! För att undvika kroppsskada när du installerar eller utför underhållsarbete på denna enhet på en ställning måste du vidta särskilda försiktighetsåtgärder för att försäkra dig om att systemet står stadigt. Följande riktlinjer ges för att trygga din säkerhet:

- Juniper Networks switch måste installeras i en ställning som är förankrad i byggnadens struktur.
- Om denna enhet är den enda enheten på ställningen skall den installeras längst ned på ställningen.
- Om denna enhet installeras på en delvis fylld ställning skall ställningen fyllas nedifrån och upp, med de tyngsta enheterna längst ned på ställningen.
- Om ställningen är försedd med stabiliseringsdon skall dessa monteras fast innan enheten installeras eller underhålls på ställningen.

Grounded Equipment Warning



WARNING: This device must be properly grounded at all times. Follow the instructions in this guide to properly ground the device to earth.

Waarschuwing Dit apparaat moet altijd goed geaard zijn. Volg de instructies in deze gids om het apparaat goed te aarden.

Varoitus Laitteen on oltava pysyvästi maadoitettu. Maadoita laite asianmukaisesti noudattamalla tämän oppaan ohjeita.

Avertissement L'appareil doit être correctement mis à la terre à tout moment. Suivez les instructions de ce guide pour correctement mettre l'appareil à la terre.

Warnung Das Gerät muss immer ordnungsgemäß geerdet sein. Befolgen Sie die Anweisungen in dieser Anleitung, um das Gerät ordnungsgemäß zu erden.

Avvertenza Questo dispositivo deve sempre disporre di una connessione a massa. Seguire le istruzioni indicate in questa guida per connettere correttamente il dispositivo a massa.

Advarsel Denne enheten på jordes skikkelig hele tiden. Følg instruksjonene i denne veiledningen for å jorde enheten.

Aviso Este equipamento deverá estar ligado à terra. Siga las instrucciones en esta guía para conectar correctamente este dispositivo a tierra.

¡Atención! Este dispositivo debe estar correctamente conectado a tierra en todo momento. Siga las instrucciones en esta guía para conectar correctamente este dispositivo a tierra.

Varning! Den här enheten måste vara ordentligt jordad. Följ instruktionerna i den här guiden för att jorda enheten ordentligt.

Radiation from Open Port Apertures Warning



LASER WARNING: Because invisible radiation might be emitted from the aperture of the port when no fiber cable is connected, avoid exposure to radiation and do not stare into open apertures.

Waarschuwing Aangezien onzichtbare straling vanuit de opening van de poort kan komen als er geen fiberkabel aangesloten is, dient blootstelling aan straling en het kijken in open openingen vermeden te worden.

Varoitus Koska portin aukosta voi emittoitua näkymätöntä säteilyä, kun kuitukaapelia ei ole kytkettyä, vältä säteilylle altistumista äläkä katso avoimiin aukkoihin.

Avertissement Des radiations invisibles à l'il nu pouvant traverser l'ouverture du port lorsqu'aucun câble en fibre optique n'y est connecté, il est recommandé de ne pas regarder fixement l'intérieur de ces ouvertures.

Warnung Aus der Port-Öffnung können unsichtbare Strahlen emittieren, wenn kein Glasfaserkabel angeschlossen ist. Vermeiden Sie es, sich den Strahlungen auszusetzen, und starren Sie nicht in die Öffnungen!

Avvertenza Quando i cavi in fibra non sono inseriti, radiazioni invisibili possono essere emesse attraverso l'apertura della porta. Evitate di esporvi alle radiazioni e non guardate direttamente nelle aperture.

Advarsel Unngå utsettelse for stråling, og stirr ikke inn i åpninger som er åpne, fordi usynlig stråling kan emitteres fra portens åpning når det ikke er tilkoblet en fiberkabel.

Aviso Dada a possibilidade de emissão de radiação invisível através do orifício da via de acesso, quando esta não tiver nenhum cabo de fibra conectado, deverá evitar a EXposição à radiação e não deverá olhar fixamente para orifícios que se encontrarem a descoberto.

¡Atención! Debido a que la apertura del puerto puede emitir radiación invisible cuando no existe un cable de fibra conectado, evite mirar directamente a las aperturas para no exponerse a la radiación.

Varning! Osynlig strålning kan avges från en portöppning utan ansluten fiberkabel och du bör därför undvika att bli utsatt för strålning genom att inte stirra in i oskyddade öppningar.

Laser and LED Safety Guidelines and Warnings

IN THIS SECTION

- [General Laser Safety Guidelines | 350](#)
- [Class 1 Laser Product Warning | 350](#)
- [Class 1 LED Product Warning | 351](#)
- [Laser Beam Warning | 351](#)

Juniper Networks devices are equipped with laser transmitters, which are considered a Class 1 Laser Product by the U.S. Food and Drug Administration and are evaluated as a Class 1 Laser Product per IEC/EN 60825-1 requirements.

Observe the following guidelines and warnings:

General Laser Safety Guidelines

When working around ports that support optical transceivers, observe the following safety guidelines to prevent eye injury:

- Do not look into unterminated ports or at fibers that connect to unknown sources.
- Do not examine unterminated optical ports with optical instruments.
- Avoid direct exposure to the beam.



LASER WARNING: Unterminated optical connectors can emit invisible laser radiation. The lens in the human eye focuses all the laser power on the retina, so focusing the eye directly on a laser source—even a low-power laser—could permanently damage the eye.

Avertissement Les connecteurs à fibre optique sans terminaison peuvent émettre un rayonnement laser invisible. Le cristallin de l'œil humain faisant converger toute la puissance du laser sur la rétine, toute focalisation directe de l'œil sur une source laser, —même de faible puissance—, peut entraîner des lésions oculaires irréversibles.

Class 1 Laser Product Warning



LASER WARNING: Class 1 laser product.

Waarschuwing Klasse-1 laser produkt.

Varoitus Luokan 1 lasertuote.

Avertissement Produit laser de classe I.

Warnung Laserprodukt der Klasse 1.

Avvertenza Prodotto laser di Classe 1.

Advarsel Laserprodukt av klasse 1.

Aviso Produto laser de classe 1.

¡Atención! Producto láser Clase I.

Varning! Laserprodukt av klass 1.

Class 1 LED Product Warning



LASER WARNING: Class 1 LED product.

Waarschuwing Klasse 1 LED-product.

Varoitus Luokan 1 valodiodituote.

Avertissement Alarme de produit LED Class I.

Warnung Class 1 LED-Produktwarnung.

Avvertenza Avvertenza prodotto LED di Classe 1.

Advarel LED-produkt i klasse 1.

Aviso Produto de classe 1 com LED.

¡Atención! Aviso sobre producto LED de Clase 1.

Varning! Lysdiodprodukt av klass 1.

Laser Beam Warning



LASER WARNING: Do not stare into the laser beam or view it directly with optical instruments.

Waarschuwing Niet in de straal staren of hem rechtstreeks bekijken met optische instrumenten.

Varoitus Älä katso säteeseen äläkä tarkastele sitä suoraan optisen laitteen avulla.

Avertissement Ne pas fixer le faisceau des yeux, ni l'observer directement à l'aide d'instruments optiques.

Warnung Nicht direkt in den Strahl blicken und ihn nicht direkt mit optischen Geräten prüfen.

Avvertenza Non fissare il raggio con gli occhi né usare strumenti ottici per osservarlo direttamente.

Advarel Stirr eller se ikke direkte p strlen med optiske instrumenter.

Aviso Não olhe fixamente para o raio, nem olhe para ele directamente com instrumentos ópticos.

¡Atención! No mirar fijamente el haz ni observarlo directamente con instrumentos ópticos.

Warning! Rikta inte blicken in mot strålen och titta inte direkt på den genom optiska instrument.

Maintenance and Operational Safety Guidelines and Warnings

IN THIS SECTION

- [Battery Handling Warning | 352](#)
- [Jewelry Removal Warning | 353](#)
- [Lightning Activity Warning | 355](#)
- [Operating Temperature Warning | 356](#)
- [Product Disposal Warning | 357](#)

While performing the maintenance activities for devices, observe the following guidelines and warnings:

Battery Handling Warning



WARNING: Replacing a battery incorrectly might result in an explosion. Replace a battery only with the same or equivalent type recommended by the manufacturer. Dispose of used batteries according to the manufacturer's instructions.

Waarschuwing Er is ontploffingsgevaar als de batterij verkeerd vervangen wordt. Vervang de batterij slechts met hetzelfde of een equivalent type dat door de fabrikant

aanbevolen is. Gebruikte batterijen dienen overeenkomstig fabrieksvoorschriften weggeworpen te worden.

Varoitus Räjähdyksen vaara, jos akku on vaihdettu väärään akkuun. Käytä vaihtamiseen ainoastaan saman- tai vastaavantyyppistä akkua, joka on valmistajan suosittama. Hävitä käytetyt akut valmistajan ohjeiden mukaan.

Avertissement Danger d'explosion si la pile n'est pas remplacée correctement. Ne la remplacer que par une pile de type semblable ou équivalent, recommandée par le fabricant. Jeter les piles usagées conformément aux instructions du fabricant.

Warnung Bei Einsetzen einer falschen Batterie besteht Explosionsgefahr. Ersetzen Sie die Batterie nur durch den gleichen oder vom Hersteller empfohlenen Batterietyp. Entsorgen Sie die benutzten Batterien nach den Anweisungen des Herstellers.

Advarsel Det kan være fare for eksplosjon hvis batteriet skiftes på feil måte. Skift kun med samme eller tilsvarende type som er anbefalt av produsenten. Kasser brukte batterier i henhold til produsentens instruksjoner.

Avvertenza Pericolo di esplosione se la batteria non è installata correttamente. Sostituire solo con una di tipo uguale o equivalente, consigliata dal produttore. Eliminare le batterie usate secondo le istruzioni del produttore.

Aviso Existe perigo de explosão se a bateria for substituída incorrectamente. Substitua a bateria por uma bateria igual ou de um tipo equivalente recomendado pelo fabricante. Destrua as baterias usadas conforme as instruções do fabricante.

¡Atención! Existe peligro de explosión si la batería se reemplaza de manera incorrecta. Reemplazar la batería EXclusivamente con el mismo tipo o el equivalente recomendado por el fabricante. Desechar las baterías gastadas según las instrucciones del fabricante.

Varning! Explosionsfara vid felaktigt batteribyte. Ersätt endast batteriet med samma batterityp som rekommenderas av tillverkaren eller motsvarande. Följ tillverkarens anvisningar vid kassering av använda batterier.

Jewelry Removal Warning



WARNING: Before working on equipment that is connected to power lines, remove jewelry, including rings, necklaces, and watches. Metal objects heat up when connected to power and ground and can cause serious burns or can be welded to the terminals.

Waarschuwing Alvorens aan apparatuur te werken die met elektrische leidingen is verbonden, sieraden (inclusief ringen, kettingen en horloges) verwijderen. Metalen voorwerpen worden warm wanneer ze met stroom en aarde zijn verbonden, en kunnen ernstige brandwonden veroorzaken of het metalen voorwerp aan de aansluitklemmen lassen.

Varoitus Ennen kuin työskentelet voimavirtajohtoihin kytkettyjen laitteiden parissa, ota pois kaikki korut (sormukset, kaulakorut ja kellot mukaan lukien). Metalliesineet kuumenevat, kun ne ovat yhteydessä sähkövirran ja maan kanssa, ja ne voivat aiheuttaa vakavia palovammoja tai hitsata metalliesineet kiinni liitännänapoihin.

Avertissement Avant d'accéder à cet équipement connecté aux lignes électriques, ôter tout bijou (anneaux, colliers et montres compris). Lorsqu'ils sont branchés à l'alimentation et reliés à la terre, les objets métalliques chauffent, ce qui peut provoquer des blessures graves ou souder l'objet métallique aux bornes.

Warnung Vor der Arbeit an Geräten, die an das Netz angeschlossen sind, jeglichen Schmuck (einschließlich Ringe, Ketten und Uhren) abnehmen. Metallgegenstände erhitzen sich, wenn sie an das Netz und die Erde angeschlossen werden, und können schwere Verbrennungen verursachen oder an die Anschlußklemmen angeschweißt werden.

Avvertenza Prima di intervenire su apparecchiature collegate alle linee di alimentazione, togliersi qualsiasi monile (inclusi anelli, collane, braccialetti ed orologi). Gli oggetti metallici si riscaldano quando sono collegati tra punti di alimentazione e massa: possono causare ustioni gravi oppure il metallo può saldarsi ai terminali.

Advarsel Fjern alle smykker (inkludert ringer, halskjeder og klokker) før du skal arbeide på utstyr som er koblet til kraftledninger. Metallgjenstander som er koblet til kraftledninger og jord blir svært varme og kan forårsake alvorlige brannskader eller smelte fast til polene.

Aviso Antes de trabalhar em equipamento que esteja ligado a linhas de corrente, retire todas as jóias que estiver a usar (incluindo anéis, fios e relógios). Os objectos metálicos aquecerão em contacto com a corrente e em contacto com a ligação à terra, podendo causar queimaduras graves ou ficarem soldados aos terminais.

¡Atención! Antes de operar sobre equipos conectados a líneas de alimentación, quitarse las joyas (incluidos anillos, collares y relojes). Los objetos de metal se calientan cuando se conectan a la alimentación y a tierra, lo que puede ocasionar quemaduras graves o que los objetos metálicos queden soldados a los bornes.

Warning! Tag av alla smycken (inklusive ringar, halsband och armbandsur) innan du arbetar på utrustning som är kopplad till kraftledning. Metallobjekt hettas upp när de kopplas ihop med ström och jord och kan förorsaka allvarliga brännskador; metallobjekt kan också sammansvetsas med kontakterna.

Lightning Activity Warning



WARNING: Do not work on the system or connect or disconnect cables during periods of lightning activity.

Waarschuwing Tijdens onweer dat gepaard gaat met bliksem, dient u niet aan het systeem te werken of kabels aan te sluiten of te ontkoppelen.

Varoitus Älä työskentele järjestelmän parissa äläkä yhdistä tai irrota kaapeleita ukkosilmalla.

Avertissement Ne pas travailler sur le système ni brancher ou débrancher les câbles pendant un orage.

Warnung Arbeiten Sie nicht am System und schließen Sie keine Kabel an bzw. trennen Sie keine ab, wenn es gewittert.

Avvertenza Non lavorare sul sistema o collegare oppure scollegare i cavi durante un temporale con fulmini.

Advarsel Utfør aldri arbeid på systemet, eller koble kabler til eller fra systemet når det tordner eller lyner.

Aviso Não trabalhe no sistema ou ligue e desligue cabos durante períodos de mau tempo (trovoada).

¡Atención! No operar el sistema ni conectar o desconectar cables durante el transcurso de descargas eléctricas en la atmósfera.

Warning! Vid åska skall du aldrig utföra arbete på systemet eller ansluta eller koppla loss kablar.

Operating Temperature Warning



WARNING: To prevent the device from overheating, do not operate it in an area that exceeds the maximum recommended ambient temperature. To prevent airflow restriction, allow at least 6 in. (15.2 cm) of clearance around the ventilation openings.

Waarschuwing Om te voorkomen dat welke switch van de Juniper Networks router dan ook oververhit raakt, dient u deze niet te bedienen op een plaats waar de maximale aanbevolen omgevingstemperatuur van 40° C wordt overschreden. Om te voorkomen dat de luchtstroom wordt beperkt, dient er minstens 15,2 cm speling rond de ventilatie-openingen te zijn.

Varoitus Ettei Juniper Networks switch-sarjan reititin ylikuumentuisi, sitä ei saa käyttää tilassa, jonka lämpötila ylittää korkeimman suositellun ympäristölämpötilan 40° C. Ettei ilmanvaihto estyisi, tuuletusaukkojen ympärille on jätettävä ainakin 15,2 cm tilaa.

Avertissement Pour éviter toute surchauffe des routeurs de la gamme Juniper Networks switch, ne l'utilisez pas dans une zone où la température ambiante est supérieure à 40° C. Pour permettre un flot d'air constant, dégagez un espace d'au moins 15,2 cm autour des ouvertures de ventilations.

Warnung Um einen Router der switch vor Überhitzung zu schützen, darf dieser nicht in einer Gegend betrieben werden, in der die Umgebungstemperatur das empfohlene Maximum von 40° C überschreitet. Um Lüftungsverschluß zu verhindern, achten Sie darauf, daß mindestens 15,2 cm lichter Raum um die Lüftungsöffnungen herum frei bleibt.

Avvertenza Per evitare il surriscaldamento dei switch, non adoperateli in un locale che ecceda la temperatura ambientale massima di 40° C. Per evitare che la circolazione dell'aria sia impedita, lasciate uno spazio di almeno 15.2 cm di fronte alle aperture delle ventole.

Advarsel Unngå overoppheting av eventuelle rutere i Juniper Networks switch Disse skal ikke brukes på steder der den anbefalte maksimale omgivelsestemperaturen overstiger 40° C (104° F). Sørg for at klaringen rundt lufteåpningene er minst 15,2 cm (6 tommer) for å forhindre nedsatt luftsirkulasjon.

Aviso Para evitar o sobreaquecimento do encaminhador Juniper Networks switch, não utilize este equipamento numa área que exceda a temperatura máxima recomendada de 40° C. Para evitar a restrição à circulação de ar, deixe pelo menos um espaço de 15,2 cm à volta das aberturas de ventilação.

¡Atención! Para impedir que un encaminador de la serie Juniper Networks switch se recaliente, no lo haga funcionar en un área en la que se supere la temperatura ambiente máxima recomendada de 40° C. Para impedir la restricción de la entrada de aire, deje un espacio mínimo de 15,2 cm alrededor de las aperturas para ventilación.

Warning! Förhindra att en Juniper Networks switch överhettas genom att inte använda den i ett område där den maximalt rekommenderade omgivningstemperaturen på 40° C överskrids. Förhindra att luftcirkulationen inskränks genom att se till att det finns fritt utrymme på minst 15,2 cm omkring ventilationsöppningarna.

Product Disposal Warning



WARNING: Disposal of this device must be handled according to all national laws and regulations.

Waarschuwing Dit produkt dient volgens alle landelijke wetten en voorschriften te worden afgedankt.

Varoitus Tämän tuotteen lopullisesta hävittämisestä tulee huolehtia kaikkia valtakunnallisia lakeja ja säännöksiä noudattaen.

Avertissement La mise au rebut définitive de ce produit doit être effectuée conformément à toutes les lois et réglementations en vigueur.

Warnung Dieses Produkt muß den geltenden Gesetzen und Vorschriften entsprechend entsorgt werden.

Avvertenza L'eliminazione finale di questo prodotto deve essere eseguita osservando le normative italiane vigenti in materia

Advarsel Endelig disponering av dette produktet må skje i henhold til nasjonale lover og forskrifter.

Aviso A descartagem final deste produto deverá ser efectuada de acordo com os regulamentos e a legislação nacional.

¡Atención! El desecho final de este producto debe realizarse según todas las leyes y regulaciones nacionales

Warning! Slutlig kassering av denna produkt bör skötas i enlighet med landets alla lagar och föreskrifter.

General Electrical Safety Guidelines and Warnings



WARNING: Certain ports on the device are designed for use as intrabuilding (within-the-building) interfaces only (Type 2 or Type 4 ports as described in *GR-1089-CORE*) and require isolation from the exposed outside plant (OSP) cabling. To comply with NEBS (Network Equipment-Building System) requirements and protect against lightning surges and commercial power disturbances, the intrabuilding ports *must not* be metallicly connected to interfaces that connect to the OSP or its wiring. The intrabuilding ports on the device are suitable for connection to intrabuilding or unexposed wiring or cabling only. The addition of primary protectors is not sufficient protection for connecting these interfaces metallicly to OSP wiring.

Avertissement Certains ports de l'appareil sont destinés à un usage en intérieur uniquement (ports Type 2 ou Type 4 tels que décrits dans le document *GR-1089-CORE*) et doivent être isolés du câblage de l'installation extérieure exposée. Pour respecter les exigences NEBS et assurer une protection contre la foudre et les perturbations de tension secteur, les ports pour intérieur *ne doivent pas* être raccordés physiquement aux interfaces prévues pour la connexion à l'installation extérieure ou à son câblage. Les ports pour intérieur de l'appareil sont réservés au raccordement de câbles pour intérieur ou non exposés uniquement. L'ajout de protections ne constitue pas une précaution suffisante pour raccorder physiquement ces interfaces au câblage de l'installation extérieure.



CAUTION: Before removing or installing components of a device, connect an electrostatic discharge (ESD) grounding strap to an ESD point and wrap and fasten the other end of the strap around your bare wrist. Failure to use an ESD grounding strap could result in damage to the device.

Attention Avant de retirer ou d'installer des composants d'un appareil, raccordez un bracelet antistatique à un point de décharge électrostatique et fixez le bracelet à votre poignet nu. L'absence de port d'un bracelet antistatique pourrait provoquer des dégâts sur l'appareil.

- Install the device in compliance with the following local, national, and international electrical codes:
 - United States—National Fire Protection Association (NFPA 70), United States National Electrical Code.
 - Other countries—International Electromechanical Commission (IEC) 60364, Part 1 through Part 7.
 - Evaluated to the TN power system.

- Canada—Canadian Electrical Code, Part 1, CSA C22.1.
- Suitable for installation in Information Technology Rooms in accordance with Article 645 of the National Electrical Code and NFPA 75.

Peut être installé dans des salles de matériel de traitement de l'information conformément à l'article 645 du National Electrical Code et à la NFPA 75.

- Locate the emergency power-off switch for the room in which you are working so that if an electrical accident occurs, you can quickly turn off the power.
- Make sure that you clean grounding surface and give them a bright finish before making grounding connections.
- Do not work alone if potentially hazardous conditions exist anywhere in your workspace.
- Never assume that power is disconnected from a circuit. Always check the circuit before starting to work.
- Carefully look for possible hazards in your work area, such as moist floors, ungrounded power extension cords, and missing safety grounds.
- Operate the device within marked electrical ratings and product usage instructions.
- To ensure that the device and peripheral equipment function safely and correctly, use the cables and connectors specified for the attached peripheral equipment, and make certain they are in good condition.

You can remove and replace many device components without powering off or disconnecting power to the device, as detailed elsewhere in the hardware documentation for this device. Never install equipment that appears to be damaged.

Action to Take After an Electrical Accident

If an electrical accident results in an injury, take the following actions in this order:

1. Use caution. Be aware of potentially hazardous conditions that could cause further injury.
2. Disconnect power from the device.
3. If possible, send another person to get medical aid. Otherwise, assess the condition of the victim, and then call for help.

Prevention of Electrostatic Discharge Damage

Device components that are shipped in antistatic bags are sensitive to damage from static electricity. Some components can be impaired by voltages as low as 30 V. You can easily generate potentially damaging static voltages whenever you handle plastic or foam packing material or if you move components across plastic or carpets. Observe the following guidelines to minimize the potential for electrostatic discharge (ESD) damage, which can cause intermittent or complete component failures:

- Always use an ESD wrist strap when you are handling components that are subject to ESD damage, and make sure that it is in direct contact with your skin.

If a grounding strap is not available, hold the component in its antistatic bag (see [Figure 104 on page 361](#)) in one hand and touch the exposed, bare metal of the device with the other hand immediately before inserting the component into the device.



WARNING: For safety, periodically check the resistance value of the ESD grounding strap. The measurement must be in the range 1 through 10 Mohms.

Avertissement Par mesure de sécurité, vérifiez régulièrement la résistance du bracelet antistatique. Cette valeur doit être comprise entre 1 et 10 mégohms (Mohms).

- When handling any component that is subject to ESD damage and that is removed from the device, make sure the equipment end of your ESD wrist strap is attached to the ESD point on the chassis.

If no grounding strap is available, touch the exposed, bare metal of the device to ground yourself before handling the component.

- Avoid contact between the component that is subject to ESD damage and your clothing. ESD voltages emitted from clothing can damage components.
- When removing or installing a component that is subject to ESD damage, always place it component-side up on an antistatic surface, in an antistatic card rack, or in an antistatic bag (see [Figure 104 on page 361](#)). If you are returning a component, place it in an antistatic bag before packing it.

Figure 104: Placing a Component into an Antistatic Bag

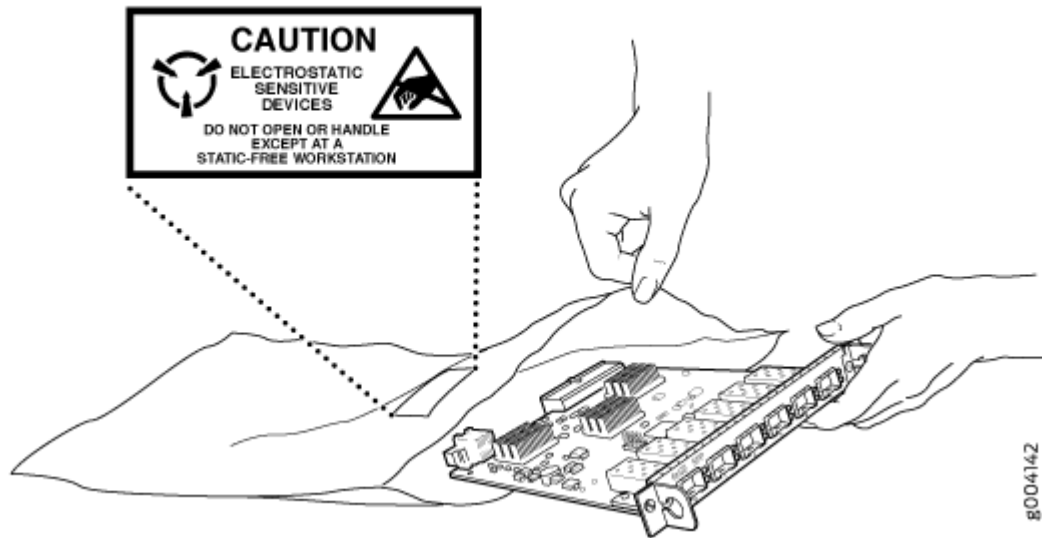

CAUTION: ANSI/TIA/EIA-568 cables such as Category 5e and Category 6 can get electrostatically charged. To dissipate this charge, always ground the cables to a suitable and safe earth ground before connecting them to the system.

Attention Les câbles ANSI/TIA/EIA-568, par exemple Cat 5e et Cat 6, peuvent emmagasiner des charges électrostatiques. Pour évacuer ces charges, reliez toujours les câbles à une prise de terre adaptée avant de les raccorder au système.

AC Power Electrical Safety Guidelines

The following electrical safety guidelines apply to AC-powered devices:

- Note the following warnings printed on the device:

“CAUTION: THIS UNIT HAS MORE THAN ONE POWER SUPPLY CORD. DISCONNECT ALL POWER SUPPLY CORDS BEFORE SERVICING TO AVOID ELECTRIC SHOCK.”

“ATTENTION: CET APPAREIL COMPORTE PLUS D'UN CORDON D'ALIMENTATION. AFIN DE PRÉVENIR LES CHOCS ÉLECTRIQUES, DÉBRANCHER TOUT CORDON D'ALIMENTATION AVANT DE FAIRE LE DÉPANNAGE.”

- AC-powered devices are shipped with a three-wire electrical cord with a grounding-type plug that fits only a grounding-type power outlet. Do not circumvent this safety feature. Equipment grounding must comply with local and national electrical codes.
- You must provide an external certified circuit breaker (2-pole circuit breaker or 4-pole circuit breaker based on your device) rated minimum 20 A in the building installation.
- The power cord serves as the main disconnecting device for the AC-powered device. The socket outlet must be near the AC-powered device and be easily accessible.
- For devices that have more than one power supply connection, you must ensure that all power connections are fully disconnected so that power to the device is completely removed to prevent electric shock. To disconnect power, unplug all power cords (one for each power supply).

Power Cable Warning (Japanese)

WARNING: The attached power cable is only for this product. Do not use the cable for another product.

注意

附属の電源コードセットはこの製品専用です。
他の電気機器には使用しないでください。

0017283

AC Power Disconnection Warning



WARNING: Before working on the device or near power supplies, unplug all the power cords from an AC-powered device.

Waarschuwing Voordat u aan een frame of in de nabijheid van voedingen werkt, dient u bij wisselstroom toestellen de stekker van het netsnoer uit het stopcontact te halen.

Varoitus Kytke irti vaihtovirtalaitteiden virtajohto, ennen kuin teet mitään asennuspohjalle tai työskentelet virtalähteiden läheisyydessä.

Avertissement Avant de travailler sur un châssis ou à proximité d'une alimentation électrique, débrancher le cordon d'alimentation des unités en courant alternatif.

Warnung Bevor Sie an einem Chassis oder in der Nähe von Netzgeräten arbeiten, ziehen Sie bei Wechselstromeinheiten das Netzkabel ab bzw.

Avvertenza Prima di lavorare su un telaio o intorno ad alimentatori, scollegare il cavo di alimentazione sulle unità CA.

Advarsel Før det utføres arbeid på kabinettet eller det arbeides i nærheten av strømforsyningsenheter, skal strømledningen trekkes ut på vekselstrømsenheter.

Aviso Antes de trabalhar num chassis, ou antes de trabalhar perto de unidades de fornecimento de energia, desligue o cabo de alimentação nas unidades de corrente alternada.

¡Atención! Antes de manipular el chasis de un equipo o trabajar cerca de una fuente de alimentación, desenchufar el cable de alimentación en los equipos de corriente alterna (CA).

Varning! Innan du arbetar med ett chassi eller nära strömförsörjningsenheter skall du för växelströmsenheter dra ur nätsladden.

DC Power Electrical Safety Guidelines

- A DC-powered device is equipped with a DC terminal block that is rated for the power requirements of a maximally configured device.
- For permanently connected equipment, a readily accessible disconnect device shall be incorporated external to the equipment.
- For pluggable equipment, the socket-outlet shall be installed near the equipment and shall be easily accessible.
- Be sure to connect the ground wire or conduit to a solid central office earth ground.
- A closed loop ring is recommended for terminating the ground conductor at the ground stud.
- Run two wires from the circuit breaker box to a source of 48 VDC.
- A DC-powered device that is equipped with a DC terminal block is intended only for installation in a restricted-access location. In the United States, a restricted-access area is one in accordance with Articles 110-16, 110-17, and 110-18 of the National Electrical Code ANSI/NFPA 70.

NOTE: Primary overcurrent protection is provided by the building circuit breaker. This breaker must protect against excess currents, short circuits, and earth grounding faults in accordance with NEC ANSI/NFPA 70.

- Ensure that the polarity of the DC input wiring is correct. Under certain conditions, connections with reversed polarity might trip the primary circuit breaker or damage the equipment.
- The marked input voltage of -48 VDC for a DC-powered device is the nominal voltage associated with the battery circuit, and any higher voltages are only to be associated with float voltages for the charging function.
- Because the device is a positive ground system, you must connect the positive lead to the terminal labeled **RTN**, the negative lead to the terminal labeled -48 VDC, and the earth ground to the device grounding points.

DC Power Disconnection Warning



WARNING: Before performing any of the DC power procedures, ensure that power is removed from the DC circuit. To ensure that all power is off, locate the circuit breaker on the panel board that services the DC circuit, switch the circuit breaker to the OFF position, and tape the device handle of the circuit breaker in the OFF position.

Waarschuwing Voordat u een van de onderstaande procedures uitvoert, dient u te controleren of de stroom naar het gelijkstroom circuit uitgeschakeld is. Om u ervan te verzekeren dat alle stroom UIT is geschakeld, kiest u op het schakelbord de stroomverbreker die het gelijkstroom circuit bedient, draait de stroomverbreker naar de UIT positie en plakt de schakelaarhendel van de stroomverbreker met plakband in de UIT positie vast.

Varoitus Varmista, että tasavirtapiirissä ei ole virtaa ennen seuraavien toimenpiteiden suorittamista. Varmistaaksesi, että virta on KATKAISTU täysin, paikanna tasavirrasta huolehtivassa kojetaulussa sijaitseva suojakytkin, käännä suojakytkin KATKAISTU-asentoon ja teippaa suojakytkimen varsi niin, että se pysyy KATKAISTU-asennossa.

Avertissement Avant de pratiquer l'une quelconque des procédures ci-dessous, vérifier que le circuit en courant continu n'est plus sous tension. Pour en être sûr, localiser le disjoncteur situé sur le panneau de service du circuit en courant continu, placer le

disjoncteur en position fermée (OFF) et, à l'aide d'un ruban adhésif, bloquer la poignée du disjoncteur en position OFF.

Warnung Vor Ausführung der folgenden Vorgänge ist sicherzustellen, daß die Gleichstromschaltung keinen Strom erhält. Um sicherzustellen, daß sämtlicher Strom abgestellt ist, machen Sie auf der Schalttafel den Unterbrecher für die Gleichstromschaltung ausfindig, stellen Sie den Unterbrecher auf AUS, und kleben Sie den Schaltergriff des Unterbrechers mit Klebeband in der AUS-Stellung fest.

Avvertenza Prima di svolgere una qualsiasi delle procedure seguenti, verificare che il circuito CC non sia alimentato. Per verificare che tutta l'alimentazione sia scollegata (OFF), individuare l'interruttore automatico sul quadro strumenti che alimenta il circuito CC, mettere l'interruttore in posizione OFF e fissarlo con nastro adesivo in tale posizione.

Advarsel Før noen av disse prosedyrene utføres, kontroller at strømmen er frakoblet likestrømkretsen. Sørg for at all strøm er slått AV. Dette gjøres ved å lokalisere strømbryteren på brytertavlen som betjener likestrømkretsen, slå strømbryteren AV og teipe bryterhåndtaket på strømbryteren i AV-stilling.

Aviso Antes de executar um dos seguintes procedimentos, certifique-se que desligou a fonte de alimentação de energia do circuito de corrente contínua. Para se assegurar que toda a corrente foi DESLIGADA, localize o disjuntor no painel que serve o circuito de corrente contínua e coloque-o na posição OFF (Desligado), segurando nessa posição a manivela do interruptor do disjuntor com fita isoladora.

¡Atención! Antes de proceder con los siguientes pasos, comprobar que la alimentación del circuito de corriente continua (CC) esté cortada (OFF). Para asegurarse de que toda la alimentación esté cortada (OFF), localizar el interruptor automático en el panel que alimenta al circuito de corriente continua, cambiar el interruptor automático a la posición de Apagado (OFF), y sujetar con cinta la palanca del interruptor automático en posición de Apagado (OFF).

Varning! Innan du utför någon av följande procedurer måste du kontrollera att strömförsörjningen till likströmskretsen är bruten. Kontrollera att all strömförsörjning är BRUTEN genom att slå AV det överspänningsskydd som skyddar likströmskretsen och tejpa fast överspänningsskyddets omkopplare i FRÅN-läget.

DC Power Grounding Requirements and Warning

An insulated grounding conductor that is identical in size to the grounded and ungrounded branch circuit supply conductors but is identifiable by green and yellow stripes is installed as part of the branch circuit that supplies the device. The grounding conductor is a separately derived system at the supply transformer or motor generator set.



WARNING: When you install the device, the ground connection must always be made first and disconnected last.

Waarschuwing Bij de installatie van het toestel moet de aardverbinding altijd het eerste worden gemaakt en het laatste worden losgemaakt.

Varoitus Laitetta asennettaessa on maahan yhdistäminen aina tehtävä ensiksi ja maadoituksen irti kytkeminen viimeiseksi.

Avertissement Lors de l'installation de l'appareil, la mise à la terre doit toujours être connectée en premier et déconnectée en dernier.

Warnung Der Erdanschluß muß bei der Installation der Einheit immer zuerst hergestellt und zuletzt abgetrennt werden.

Avvertenza In fase di installazione dell'unità, eseguire sempre per primo il collegamento a massa e disconnetterlo per ultimo.

Advarsel Når enheten installeres, må jordledningen alltid tilkobles først og frakobles sist.

Aviso Ao instalar a unidade, a ligação à terra deverá ser sempre a primeira a ser ligada, e a última a ser desligada.

¡Atención! Al instalar el equipo, conectar la tierra la primera y desconectarla la última.

Warning! Vid installation av enheten måste jordledningen alltid anslutas först och kopplas bort sist.

DC Power Wiring Sequence Warning



WARNING: Wire the DC power supply using the appropriate lugs. When connecting power, the proper wiring sequence is ground to ground, +RTN to +RTN, then -48 V to -

48 V. When disconnecting power, the proper wiring sequence is -48 V to -48 V, +RTN to +RTN, then ground to ground. Note that the ground wire must always be connected first and disconnected last.

Waarschuwing De juiste bedradingsvolgorde verbonden is aarde naar aarde, +RTN naar +RTN, en -48 V naar -48 V. De juiste bedradingsvolgorde losgemaakt is en -48 naar -48 V, +RTN naar +RTN, aarde naar aarde.

Varoitus Oikea yhdistettävä kytkentäjäjestys on maajohto maajohtoon, +RTN varten +RTN, -48 V varten -48 V. Oikea irrotettava kytkentäjäjestys on -48 V varten -48 V, +RTN varten +RTN, maajohto maajohtoon.

Avertissement Câblez l'alimentation d'alimentation CC En utilisant les crochets appropriés à l'extrémité de câblage. En reliant la puissance, l'ordre approprié de câblage est rectifié pour rectifier, +RTN à +RTN, puis -48 V à -48 V. En débranchant la puissance, l'ordre approprié de câblage est -48 V à -48 V, +RTN à +RTN, a alors rectifié pour rectifier. Notez que le fil de masse devrait toujours être relié d'abord et débranché pour la dernière fois. Notez que le fil de masse devrait toujours être relié d'abord et débranché pour la dernière fois.

Warnung Die Stromzufuhr ist nur mit geeigneten Ringösen an das DC Netzteil anzuschliessen. Die richtige Anschlusssequenz ist: Erdanschluss zu Erdanschluss, +RTN zu +RTN und dann -48V zu -48V. Die richtige Sequenz zum Abtrennen der Stromversorgung ist -48V zu -48V, +RTN zu +RTN und dann Erdanschluss zu Erdanschluss. Es ist zu beachten dass der Erdanschluss immer zuerst angeschlossen und als letztes abgetrennt wird.

Avvertenza Mostra la morsettiera dell'alimentatore CC. Cablare l'alimentatore CC usando i connettori adatti all'estremità del cablaggio, come illustrato. La corretta sequenza di cablaggio è da massa a massa, da positivo a positivo (da linea ad L) e da negativo a negativo (da neutro a N). Tenere presente che il filo di massa deve sempre venire collegato per primo e scollegato per ultimo.

Advarsel Riktig tilkoples tilkoplingssekvens er jord til jord, +RTN til +RTN, -48 V til -48 V. Riktig frakoples tilkoplingssekvens er -48 V til -48 V, +RTN til +RTN, jord til jord.

Aviso Ate con alambre la fuente de potencia cc Usando los terminales apropiados en el extremo del cableado. Al conectar potencia, la secuencia apropiada del cableado se muele para moler, +RTN a +RTN, entonces -48 V a -48 V. Al desconectar potencia, la secuencia apropiada del cableado es -48 V a -48 V, +RTN a +RTN, entonces molió para moler. Observe que el alambre de tierra se debe conectar siempre primero y desconectar por último. Observe que el alambre de tierra se debe conectar siempre primero y desconectar por último.

¡Atención! Wire a fonte de alimentação de DC Usando os talões apropriados nan Extremidade da fiação. Ao conectar a potência, a seqüência apropriada da fiação é moída para moer, +RTN a +RTN, então -48 V a -48 V. Ao desconectar a potência, a seqüência apropriada da fiação é -48 V a -48 V, +RTN a +RTN, moeu então para moer. Anote que o fio à terra deve sempre ser conectado primeiramente e desconectado por último. Anote que o fio à terra deve sempre ser conectado primeiramente e desconectado por último.

Warning! Korrekt kopplingssekvens ar jord till jord, +RTN till +RTN, -48 V till -48 V. Korrekt kopplas kopplingssekvens ar -48 V till -48 V, +RTN till +RTN, jord till jord.

DC Power Wiring Terminations Warning



WARNING: When stranded wiring is required, use approved wiring terminations, such as closed-loop or spade-type with upturned lugs. These terminations must be the appropriate size for the wires and must clamp both the insulation and conductor.

Waarschuwing Wanneer geslagen bedrading vereist is, dient u bedrading te gebruiken die voorzien is van goedgekeurde aansluitingspunten, zoals het gesloten-lus type of het grijperschop type waarbij de aansluitpunten omhoog wijzen. Deze aansluitpunten dienen de juiste maat voor de draden te hebben en dienen zowel de isolatie als de geleider vast te klemmen.

Varoitus Jos säikeellinen johdin on tarpeen, käytä hyväksyttyä johdinliitintää, esimerkiksi suljettua silmukkaa tai kourumaista liitintää, jossa on ylöspäin käännetyt kiinnityskorvat. Tällaisten liitintöjen tulee olla kooltaan johtimiin sopivia ja niiden tulee puristaa yhteen sekä eristeen että johdinosan.

Avertissement Quand des fils torsadés sont nécessaires, utiliser des douilles terminales homologuées telles que celles à circuit fermé ou du type à plage ouverte avec cosses rebroussées. Ces douilles terminales doivent être de la taille qui convient aux fils et doivent être refermées sur la gaine isolante et sur le conducteur.

Warnung Wenn Litzenverdrahtung erforderlich ist, sind zugelassene Verdrahtungsabschlüsse, z.B. für einen geschlossenen Regelkreis oder gabelförmig, mit nach oben gerichteten Kabelschuhen zu verwenden. Diese Abschlüsse sollten die angemessene Größe für die Drähte haben und sowohl die Isolierung als auch den Leiter festklemmen.

Avvertenza Quando occorre usare trecce, usare connettori omologati, come quelli a occhio o a forcella con linguette rivolte verso l'alto. I connettori devono avere la misura adatta per il cablaggio e devono serrare sia l'isolante che il conduttore.

Advarsel Hvis det er nødvendig med flertrådede ledninger, brukes godkjente ledningsavslutninger, som for eksempel lukket sløyfe eller spadetype med oppoverbøyde kabelsko. Disse avslutningene skal ha riktig størrelse i forhold til ledningene, og skal klemme sammen både isolasjonen og ledaren.

Aviso Quando forem requeridas montagens de instalação eléctrica de cabo torcido, use terminações de cabo aprovadas, tais como, terminações de cabo em circuito fechado e planas com terminais de orelha voltados para cima. Estas terminações de cabo deverão ser do tamanho apropriado para os respectivos cabos, e deverão prender simultaneamente o isolamento e o fio condutor.

¡Atención! Cuando se necesite hilo trenzado, utilizar terminales para cables homologados, tales como las de tipo "bucle cerrado" o "espada", con las lengüetas de conexión vueltas hacia arriba. Estos terminales deberán ser del tamaño apropiado para los cables que se utilicen, y tendrán que sujetar tanto el aislante como el conductor.

Varning! När flertrådiga ledningar krävs måste godkända ledningskontakter användas, t.ex. kabelsko av slutet eller öppen typ med uppåtvänd tapp. Storleken på dessa kontakter måste vara avpassad till ledningarna och måste kunna hålla både isoleringen och ledaren fastklämda.

Multiple Power Supplies Disconnection Warning



WARNING: The network device has more than one power supply connection. All connections must be removed completely to remove power from the unit completely.

Waarschuwing Deze eenheid heeft meer dan één stroomtoevoerverbinding; alle verbindingen moeten volledig worden verwijderd om de stroom van deze eenheid volledig te verwijderen.

Varoitus Tässä laitteessa on useampia virtalähdekytkentöjä. Kaikki kytkennät on irrotettava kokonaan, jotta virta poistettaisiin täysin laitteesta.

Avertissement Cette unité est équipée de plusieurs raccordements d'alimentation. Pour supprimer tout courant électrique de l'unité, tous les cordons d'alimentation doivent être débranchés.

Warnung Diese Einheit verfügt über mehr als einen Stromanschluß; um Strom gänzlich von der Einheit fernzuhalten, müssen alle Stromzufuhren abgetrennt sein.

Avvertenza Questa unità ha più di una connessione per alimentatore elettrico; tutte le connessioni devono essere completamente rimosse per togliere l'elettricità dall'unità.

Advarsel Denne enheten har mer enn én strømtilkobling. Alle tilkoblinger må kobles helt fra for å eliminere strøm fra enheten.

Aviso Este dispositivo possui mais do que uma conexão de fonte de alimentação de energia; para poder remover a fonte de alimentação de energia, deverão ser desconectadas todas as conexões existentes.

¡Atención! Esta unidad tiene más de una conexión de suministros de alimentación; para eliminar la alimentación por completo, deben desconectarse completamente todas las conexiones.

Warning! Denna enhet har mer än en strömförsörjningsanslutning; alla anslutningar måste vara helt avlägsnade innan strömtillförseln till enheten är fullständigt bruten.

TN Power Warning



WARNING: The device is designed to work with a TN power system.

Waarschuwing Het apparaat is ontworpen om te functioneren met TN energiesystemen.

Varoitus Koje on suunniteltu toimimaan TN-sähkövoimajärjestelmien yhteydessä.

Avertissement Ce dispositif a été conçu pour fonctionner avec des systèmes d'alimentation TN.

Warnung Das Gerät ist für die Verwendung mit TN-Stromsystemen ausgelegt.

Avvertenza Il dispositivo è stato progettato per l'uso con sistemi di alimentazione TN.

Advarsel Utstyret er utfomet til bruk med TN-strømsystemer.

Aviso O dispositivo foi criado para operar com sistemas de corrente TN.

¡Atención! El equipo está diseñado para trabajar con sistemas de alimentación tipo TN.

Varning! Enheten är konstruerad för användning tillsammans med elkraftssystem av TN-typ.

Agency Approvals for EX Series Switches

IN THIS SECTION

- [Compliance Statement for Argentina | 372](#)

This topic applies to hardware devices in the EX Series product family, which includes EX Series switches, the EX Series Redundant Power System (RPS), and the XRE200 External Routing Engine.

These hardware devices comply with the following standards:

- Safety
 - CAN/CSA-C22.2 No. 60950-1 Information Technology Equipment
 - CAN/CSA-C22.2 No. 62368-1 Information Technology Equipment
 - UL 60950-1 Information Technology Equipment
 - UL 62368-1 Second Edition
 - EN 60950-1 Information Technology Equipment
 - EN 62368-1 Second Edition
 - IEC 60950-1 Information Technology Equipment
 - IEC 62368-1 Second Edition
 - EN 60825-1 Safety of Laser Products - Part 1: Equipment classification and requirements
- EMC
 - FCC 47CFR Part 15 Class A (USA)

- EN 55022 Class A Emissions (Europe)
- ICES-003 Class A
- VCCI Class A (Japan)
- AS/NZS CISPR 22 Class A (Australia/New Zealand)
- CISPR 22 Class A
- EN 55024
- EN 300386
- EN 61000-3-2 Power Line Harmonics
- EN 61000-3-3 Voltage Fluctuations and Flicker
- EN 61000-4-2 ESD
- EN 61000-4-3 Radiated Immunity
- EN 61000-4-4 EFT
- EN 61000-4-5 Surge
- EN 61000-4-6 Low Frequency Common Immunity
- EN 61000-4-11 Voltage Dips and Sags

Compliance Statement for Argentina

EQUIPO DE USO IDÓNEO.

Battery Compliance Statement for Environmental Requirements for EX Series Switches

EX6200 and EX8200 Ethernet switches contain lithium batteries.

Batteries used in these switches are not based on substances containing mercury, lead, or cadmium. The batteries used in these switches comply with EU Directives 91/157/EEC, 93/86/EEC, and 98/101/EEC.

The product documentation includes instructional information on the proper method of reclamation and recycling.

RELATED DOCUMENTATION

Agency Approvals for EX Series Switches

Compliance Statements for EMC Requirements for EX Series Switches

Compliance Statements for EMC Requirements for EX Series Switches

IN THIS SECTION

- [Canada | 373](#)
- [Taiwan | 374](#)
- [European Community | 374](#)
- [Israel | 375](#)
- [Japan | 375](#)
- [Korea | 375](#)
- [United States | 376](#)
- [FCC Part 15 Statement | 376](#)

This topic applies to hardware devices in the EX Series product family, which includes EX Series switches, the EX Series Redundant Power System (RPS), and the XRE200 External Routing Engine.

This topic describes the EMC requirements for these hardware devices.

Canada

This Class A digital apparatus complies with Canadian ICES-003.

Cet appareil numérique de la classe A est conforme à la norme NMB-003 du Canada.

The Industry Canada label identifies certified equipment. This certification means that the equipment meets certain telecommunications network protective, operational, and safety requirements. Industry Canada does not guarantee the equipment will operate to the users' satisfaction.

Before installing this equipment, users should ensure that it is permissible to connect the equipment to the facilities of the local telecommunications company. The equipment must also be installed using an acceptable method of connection. In some cases, the inside wiring associated with a single line individual service can be extended by means of a certified connector assembly. The customer should be aware that compliance with the above conditions might not prevent degradation of service in some situations.

Repairs to certified equipment should be made by an authorized Canadian maintenance facility designated by the supplier. Any repairs or alterations made by the user to this equipment, or equipment malfunctions, might give the telecommunications company cause to request the user to disconnect the equipment.



CAUTION: Users should not attempt to make electrical ground connections by themselves, but should contact the appropriate inspection authority or an electrician, as appropriate.

Users should ensure for their own protection that the electrical ground connections of the power utility, telephone lines, and internal metallic water pipe system, if present, are connected together. This precaution might be particularly important in rural areas.

Taiwan

此為甲類資訊技術設備。於一般家居環境使用時，本設備可能導致射頻干擾，用者請採取相應措施。

The preceding translates as follows:

This is a Class A device. In a domestic environment, this device might cause radio interference, in which case the user needs to take adequate measures.

European Community

This is a Class A device. In a domestic environment this device might cause radio interference, in which case the user needs to take adequate measures.

Israel

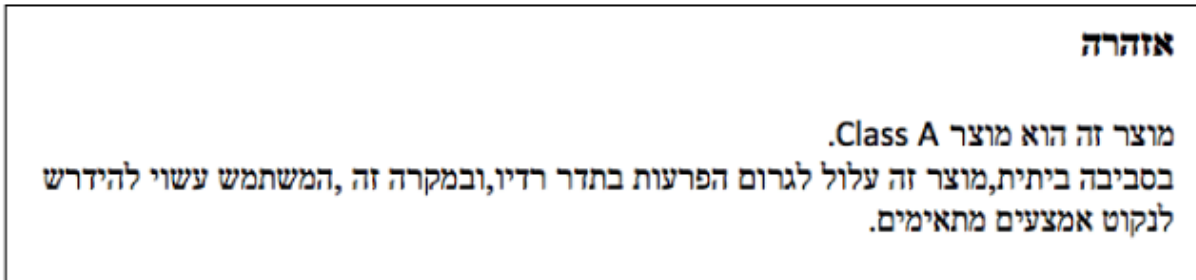

The preceding translates as follows:

Warning: This product is Class A. In residential environments, the product may cause radio interference, and in such a situation, the user may be required to take adequate measures.

Japan

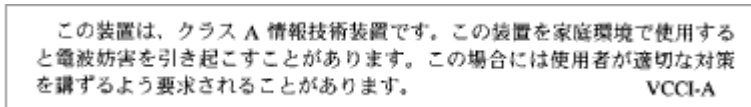

The preceding translates as follows:

This is a Class A device. In a domestic environment this device might cause radio interference, in which case the user needs to take adequate measures.

VCCI-A

Korea

이 기기는 업무용(A급) 전자파적합기기로서 판매자 또는 사용자는 이 점을 주의하시기 바라며, 가정외의 지역에서 사용하는 것을 목적으로 합니다.

Korean Class A Warning

The preceding translates as follows:

This equipment is Industrial (Class A) electromagnetic wave suitability equipment and seller or user should take notice of it, and this equipment is to be used in the places except for home

United States

The device has been tested and found to comply with the limits for a Class A digital device, pursuant to Part 15 of the FCC Rules. These limits are designed to provide reasonable protection against harmful interference when the equipment is operated in a commercial environment. This equipment generates, uses, and can radiate radio frequency energy and, if not installed and used in accordance with the instruction manual, might cause harmful interference to radio communications. Operation of this equipment in a residential area is likely to cause harmful interference, in which case users need to correct the interference at their own expense.

FCC Part 15 Statement

This equipment has been tested and found to comply with the limits for a Class A digital device pursuant to Part 15 of the FCC Rules. These limits are designed to provide reasonable protection against harmful interference in a residential installation. This equipment generates, uses, and can radiate radio frequency energy and, if not installed and used in accordance with the instructions, might cause harmful interference to radio communications. However, there is no guarantee that interference will not occur in a particular installation.

If this equipment does cause harmful interference to radio or television reception, which can be determined by turning the equipment off and on, the user is encouraged to try and correct the interference by one or more of the following measures:

- Reorient or relocate the receiving antenna.
- Increase the separation between the equipment and the receiver.
- Connect the equipment into an outlet on a circuit different from that to which the receiver is connected.
- Consult the dealer or an experienced radio or TV technician for help.

Compliance Statements for Acoustic Noise for EX Series Switches

This topic applies to hardware devices in the EX Series product family, which includes EX Series switches, the EX Series Redundant Power System (RPS), and the XRE200 External Routing Engine.

Maschinenlärminformations-Verordnung - 3. GPSGV, der höchste Schalldruckpegel beträgt 70 dB(A) oder weniger gemäss EN ISO 7779

Translation: The emitted sound pressure is below 70 dB(A) per EN ISO 7779.