

# Juniper Networks JA2500 Junos Space Appliance Hardware Guide

Published  
2023-06-30

Juniper Networks, Inc.  
1133 Innovation Way  
Sunnyvale, California 94089  
USA  
408-745-2000  
www.juniper.net

Juniper Networks, the Juniper Networks logo, Juniper, and Junos are registered trademarks of Juniper Networks, Inc. in the United States and other countries. All other trademarks, service marks, registered marks, or registered service marks are the property of their respective owners.

Juniper Networks assumes no responsibility for any inaccuracies in this document. Juniper Networks reserves the right to change, modify, transfer, or otherwise revise this publication without notice.

*Juniper Networks JA2500 Junos Space Appliance Hardware Guide*  
Copyright © 2023 Juniper Networks, Inc. All rights reserved.

The information in this document is current as of the date on the title page.

## YEAR 2000 NOTICE

Juniper Networks hardware and software products are Year 2000 compliant. Junos OS has no known time-related limitations through the year 2038. However, the NTP application is known to have some difficulty in the year 2036.

## END USER LICENSE AGREEMENT

The Juniper Networks product that is the subject of this technical documentation consists of (or is intended for use with) Juniper Networks software. Use of such software is subject to the terms and conditions of the End User License Agreement ("EULA") posted at <https://support.juniper.net/support/eula/>. By downloading, installing or using such software, you agree to the terms and conditions of that EULA.

# Table of Contents

**About This Guide | viii**

1

## **Overview**

**Appliance Overview | 2**

Junos Space Appliance Overview | 2

Field-Replaceable Units on the JA2500 Junos Space Appliance | 3

Junos Space Ethernet Interfaces Overview | 4

NTP Time Source for a Junos Space Appliance | 8

**Chassis | 10**

Chassis Physical Specifications for the JA2500 Appliance | 10

Front Panel of a JA2500 Appliance | 11

Rear Panel of a JA2500 Appliance | 13

Chassis Console Port Pinouts | 14

2

## **Site Planning and Specifications**

**Site Preparation | 17**

General Site Guidelines for Junos Space Appliances | 17

Site Electrical Wiring Guidelines | 18

Environmental Requirements and Specifications for Junos Space Appliances | 19

**Rack Requirements | 21**

Junos Space Appliance Rack Requirements | 21

**Power Requirements | 23**

AC Power Cord Specifications for Junos Space Appliances | 23

AC Power Supply in Junos Space Appliances | 25

DC Power Supply in Junos Space Appliances | 27

**Compliance | 30**

Agency Approvals for JA2500 | 30

Compliance Statements for EMC Requirements for JA2500 | 32

Compliance Statements for Acoustic Noise for JA2500 | 34

Declaration of Conformity for JA2500 Junos Space Appliance | 36

3

## **Safety and Regulatory Compliance Information**

### **General Safety Information | 39**

General Safety Guidelines and Warnings | 39

Definitions of Safety Warning Levels | 40

Fire Safety Requirements | 42

Qualified Personnel Warning | 43

Warning Statement for Norway and Sweden | 44

### **Radiation and Laser Warnings | 46**

Radiation from Open Port Apertures Warning | 46

Laser and LED Safety Guidelines and Warnings for Junos Space Appliances | 47

### **Installation and Maintenance Safety Information | 51**

Installation Instructions Warning | 51

Chassis Lifting Guidelines for Junos Space Appliances | 52

Ramp Warning | 53

Rack-Mounting Warnings | 53

Grounded Equipment Warning | 58

Maintenance and Operational Safety Guidelines and Warnings | 59

### **Power and Electrical Safety Information | 65**

General Electrical Safety Guidelines and Warnings | 65

Preventing Electrostatic Discharge Damage | 67

AC Power Electrical Safety Guidelines | 68

AC Power Disconnection Warning | 70

- DC Power Electrical Safety Guidelines | 71
- DC Power Disconnection Warning | 72
- DC Power Grounding Requirements and Warning | 74
- DC Power Wiring Sequence Warning | 75
- DC Power Wiring Terminations Warning | 76
- Multiple Power Supplies Disconnection Warning | 78
- TN Power Warning | 78
- Action to Take After an Electrical Accident | 79

## 4

## Installation and Configuration

### Installing the Appliance | 81

- Tools and Parts Required to Install the Junos Space Appliance | 81
- Unpacking the JA2500 Junos Space Appliance | 82
- Mounting the JA2500 Junos Space Appliance | 83
- Front-and-Rear Mounting the JA2500 Junos Space Appliance Flush to a Rack | 84
- Front-and-Rear Mounting the JA2500 Junos Space Appliance Recessed in a Rack | 85
- Midmounting the Junos Space Appliance in a Two-Post Rack | 86

### Connecting the Appliance | 88

- Connecting AC Power to the Junos Space Appliance | 88
- Connecting DC Power to the Junos Space Appliance | 90
- Connecting a Junos Space Appliance to the Network | 93
- Connecting a Junos Space Appliance to a Management Console | 94

### Performing Initial Configuration | 96

- Booting the Junos Space Appliance | 96
- Configuring a Junos Space Appliance as a Junos Space Node | 97
  - Configuring a Junos Space Appliance as a Junos Space Node | 100
  - Configuring Access to Junos Space Through a NAT Gateway | 116
  - Configuring the eth1 Interface | 122

Configuring a Junos Space Appliance as a Standalone or Primary FMPM Node | 123

Configuring a Junos Space Appliance as the Primary FMPM Node | 125

Configuring the eth1 Interface | 133

Configuring a Junos Space Appliance as a Backup or Secondary FMPM Node for High Availability | 134

Configuring a Junos Space Appliance as the Secondary FMPM Node | 136

Configuring the eth1 Interface | 141

Installing a Junos Space Image on a Junos Space Appliance by Using a USB Drive | 142

Powering Off the Junos Space Appliance | 148

Powering Off Using the Management Console | 149

Powering Off Using the Appliance Power Switch | 150

**Changing Network and System Settings | 151**

Changing Network and System Settings for a Junos Space Appliance | 151

Changing the Password for the Default User | 153

Changing Network Settings | 153

Modifying the IP Address of the eth1 Interface | 156

Changing the Time Zone and NTP Servers | 157

Retrieving and Transferring System Log Files | 157

Changing Firewall and SSH Settings | 158

Accessing the Shell | 158

Applying or Cancelling Changes to Settings | 159

## 5

**Maintenance and Replacing Components**

**Replacing Components | 161**

Installing and Removing JA2500 Junos Space Appliance Hardware Components | 161

Replacing the AC Power Supply Cord on a Junos Space Appliance | 162

Disconnecting the AC Power Supply Cord | 162

Connecting the AC Power Supply Cord | 163

Replacing the AC Power Supply Module on a Junos Space Appliance | 164

Removing the AC Power Supply Module | 164

Installing the AC Power Supply Module | 165

Replacing the DC Power Supply Cable on a Junos Space Appliance | 167

Removing the DC Power Supply Cable | 167

- | Connecting the DC Power Supply Cable | 168

Replacing the DC Power Supply Module on a Junos Space Appliance | 169

- | Removing the DC Power Supply Module | 169

- | Installing a DC Power Supply Module | 170

Replacing the Fan on a Junos Space Appliance | 171

- | Removing the Fan | 172

- | Installing the Fan | 173

Replacing the Hard Disk on a JA2500 Junos Space Appliance | 174

- | Removing the Hard Disk | 175

- | Installing the Hard Disk | 176

**Maintenance | 178**

Maintaining the Junos Space Appliance | 178

6

## Troubleshooting

**Troubleshooting Procedures | 181**

Troubleshooting Junos Space Ethernet Interface eth3 Connectivity | 181

**Monitoring the Appliance | 183**

Monitoring the Cooling Fans in a Junos Space Appliance | 183

Monitoring the Power Supply in a Junos Space Appliance | 186

Monitoring the RAID Array for the JA2500 Junos Space Appliance | 188

**Returning Hardware | 194**

Returning a JA2500 Junos Space Appliance or Component for Repair or Replacement | 194

Locating the Serial Number on a JA2500 Junos Space Appliance or Component | 195

- | Listing the JA2500 Appliance Details using the Junos Space CLI | 195

- | Locating the Chassis Serial Number ID Label on a JA2500 Appliance | 196

- | Locating the Serial Number ID Labels on FRUs in the JA2500 Appliance | 197

Contacting Customer Support to Obtain Return Materials Authorization for Junos Space Appliances | 197

Packing a JA2500 Junos Space Appliance or Component for Shipping | 199

- | Packing a JA2500 Appliance for Shipping | 199

- | Packing Components of the JA2500 Appliance for Shipping | 200

# About This Guide

Use this guide to install and configure the JA2500 Junos Space Appliance. After completing the installation and basic configuration procedures covered in this guide, refer to the Junos Space Network Management Platform documentation for information about further software configuration.

## RELATED DOCUMENTATION

[JA2500 Quick Start Guide](#)

---

[Junos Space Virtual Appliance Installation and Configuration Guide](#)

---

[Junos Space Release 17.2 Documentation](#)



# 1

PART

## Overview

---

Appliance Overview | 2

Chassis | 10

---

# Appliance Overview

## IN THIS CHAPTER

- [Junos Space Appliance Overview | 2](#)
- [Field-Replaceable Units on the JA2500 Junos Space Appliance | 3](#)
- [Junos Space Ethernet Interfaces Overview | 4](#)
- [NTP Time Source for a Junos Space Appliance | 8](#)

## Junos Space Appliance Overview

The Juniper Networks Junos Space Appliance is a dedicated hardware device that is engineered to provide the computing power and meet specific requirements to be able to install and run the Junos Space Network Management Platform. Junos Space Network Management Platform is an open, extensible platform that simplifies the management and orchestration of networks, and allows you to develop and host applications that simplify network operations, scale services, and automate support. The all-in-one design of the Junos Space Appliance enables administrators to easily deploy Junos Space Network Management Platform.

Junos Space Appliances are currently available in one model: JA2500.

The JA2500 appliance has a 2-U, rack-mountable chassis with dimensions of 17.81 in. x 17.31 in. x 3.5 in. (45.2 cm x 44 cm x 8.89 cm). The JA2500 appliance ships with a single AC power supply module; an additional power supply module can be installed in the power supply slot in the rear panel of the appliance. In addition, the JA2500 appliance can also be powered on by using one or two DC power supply modules.

The appliance has six 1-TB hard drives in a RAID 10 configuration. Two externally accessible cooling fans provide the required airflow and cooling for the appliance.

## RELATED DOCUMENTATION

[Chassis Physical Specifications for the JA2500 Appliance | 10](#)

[Front Panel of a JA2500 Appliance | 11](#)

## Field-Replaceable Units on the JA2500 Junos Space Appliance

Field-replaceable units (FRUs) are components that you can replace at your site. The FRUs in the JA2500 Junos Space Appliance are of the following types:

- Hot-swappable FRUs: You can remove and replace these components without powering off the appliance.
- Cold-swappable FRUs: You must power off the appliance in order to remove, replace, or add these components.

The FRUs supported in the JA2500 appliance are listed in [Table 1 on page 3](#).

**Table 1: JA2500 Appliance FRUs**

FRU	Type
AC power supply	Cold-swappable, if the appliance has only one power supply module Hot-swappable, if the appliance has an additional redundant, functioning power supply module that is plugged into a separate power circuit
Cooling fans	Hot-swappable
DC power supply	Cold-swappable, if the appliance has only one power supply module Hot-swappable, if the appliance has an additional redundant, functioning power supply module that is plugged into a separate power circuit
Hard disks	Hot-swappable

### RELATED DOCUMENTATION

## Junos Space Ethernet Interfaces Overview

This topic applies to the following Junos Space Appliances: JA1500 and JA2500.

A Junos Space Appliance has four Ethernet interfaces; three interfaces can be used and one is reserved for future use. The Ethernet interfaces are labeled **ETH0**, **ETH1**, **ETH2**, and **ETH3** for the JA1500 Junos Space Appliance, and **0**, **1**, **2**, and **3** for the JA2500 Junos Space Appliance.

The Ethernet interfaces eth0 and eth3 support both IPv4 and IPv6 addresses. As a separate IP address is available for each IP stack, for any connection initiated by Junos Space, the source IP address (that is, the IPv4 or IPv6 address) of the connection is bound by the IP address type of a managed device. For a connection initiated by a managed device, Junos Space listens on both IPv4 and IPv6 addresses of the device management interface (eth3). Therefore, a managed device can communicate with Junos Space by using its IPv4 or IPv6 address.

**NOTE:** From Junos Space Network Management Platform Release 14.1R2 onward, you can configure Junos Space Ethernet interfaces with only IPv4 addresses, or both IPv4 and IPv6 addresses.

**NOTE:** Starting in Junos Space Network Management Platform Release 21.1R1, Ethernet interface order is changed for the JA2500 Junos Space Appliance.

Physical Ethernet connection in the JA2500 appliance needs to be altered as below:

1. Cable in eth0 needs to be connected to eth3 port that is as per notations on the JA2500 appliance front panel 3.
2. Cable in eth1 needs to be connected to eth2 port that is as per notations on the JA2500 appliance front panel 2.
3. Cable in eth2 needs to be connected to eth1 port that is as per notations on the JA2500 appliance front panel 1.
4. Cable in eth3 needs to be connected to eth0 port that is as per notations on the JA2500 appliance front panel 0.

Junos Space supports managed devices based on the IP address type (that is, the IPv4 or IPv6 address) configured for the device management interface. You can configure an IPv4 or IPv6 address for the device management interface. If the device management interface is not configured, the IP address type of the node management interface (eth0) is considered for communication with managed devices. [Table 2 on page 5](#) details the support matrix for IPv4 and IPv6 address configurations on the device management interface.

**Table 2: Matrix for IP Address Versions Supported on Devices**

eth0		eth3		IP Address of Managed Devices Supported by Junos Space
IPv4 Address	IPv6 Address	IPv4 Address	IPv6 Address	
Configured	Not Configured	Not Configured	Not Configured	IPv4
Configured	Configured	Not Configured	Not Configured	IPv4 and IPv6
Configured	Not Configured	Configured	Not Configured	IPv4
Configured	Not Configured	Configured	Configured	IPv4 and IPv6
Configured	Not Configured	Not Configured	Configured	IPv6
Configured	Configured	Configured	Configured	IPv4 and IPv6

You can use the Ethernet interfaces as follows:

- eth0—Use the eth0 interface to configure the virtual IP (VIP) address of a fabric and the IP address of the node as well as to access the managed devices. The VIP address and the IP address of the node should be on the same subnet.

The eth0:0 subinterface provides access to the Junos Space Network Management Platform GUI. You can access the GUI by using the VIP address of the fabric.

- eth1—Use the eth1 interface as an administrative interface of a Junos Space node. Use SSH to access a Junos Space node through this interface. The eth0 interface and the eth1 interface can be on different subnets.

If you configure eth1, you cannot access the Junos Space nodes using the eth0 interface. You can access the CLI of the Junos Space node only through the eth1 interface.

- eth2—The eth2 interface is reserved for future use.
- eth3—Use the eth3 interface as the device management interface for SSH access to managed devices when the managed devices are on an out-of-band management subnet or on a subnet not accessible through the eth0 interface.

**NOTE:**

- If the managed devices are not accessible through the default *gateway*, you must configure static routes. Any *static route* configured manually is populated in the main *routing table*, which is used to route traffic through the eth0 interface.
- When the eth3 interface is configured as a device management interface, Junos Space Platform does not forward ICMP packets through the eth3 interface. To allow ICMP packets through the eth3 interface, routes must be added manually.

- When you configure an appliance as a Junos Space node, you can configure the Ethernet interfaces as follows:

- Configure only the eth0 interface.

When only Ethernet interface (eth0) is used, the Junos Space nodes in the fabric, virtual IP (VIP) address of the fabric, and the devices being managed by Junos Space are on the same subnet.

- Configure the eth0 and eth3 interfaces.

When Ethernet interfaces eth0 and eth3 are used, the Junos Space nodes in the fabric and VIP address of the fabric are on the same subnet and are reachable through Ethernet interface **ETH0** (JA1500 appliance) or Ethernet interface **0** (JA2500 appliance). The devices being managed by Junos Space are on the same subnet, which is different from the one reachable through Ethernet interface **ETH0** or Ethernet interface **0**, and are reachable through Ethernet interface **ETH3** (JA1500 appliance) or Ethernet interface **3** (JA2500 appliance).

- Configure the eth0 and eth1 interfaces.

When Ethernet interfaces eth0 and eth1 are used, the Junos Space nodes in the fabric and the VIP address of the fabric may or may not be on the same subnet. The eth1 interface provides SSH access to the Junos Space nodes.

The VIP address and the devices being managed by Junos Space are on the same subnet.

- Configure the eth0, eth1, and eth3 interfaces.

When Ethernet interfaces eth0, eth1, and eth3 are used, the Junos Space nodes in the fabric and the VIP address of the fabric may or may not be on the same subnet. The Junos Space nodes are reachable (SSH access) only through the eth1 interface.

The managed devices can be reached through the eth0 interface if they are configured on the same subnet as the VIP address; on any other subnet, the managed devices can be reached through the eth3 interface.

**NOTE:** If the managed devices are not reachable through the default gateway configured for the eth3 interface, you must configure static routes for the eth3 interface. The eth3 interface refers to the devint routing table.

Any static route configured manually is populated in the main routing table, which is used to route traffic through the eth0 interface.

- When you configure an appliance as a specialized node used for fault monitoring and performance monitoring (FMPM), you can use only the Ethernet interfaces eth0 and eth1.

Ethernet interface eth1 provides SSH access to FMPM nodes.

**NOTE:** For more information about the Junos Space fabric, refer to the *Managing Nodes in the Junos Space Fabric* chapter in the *Junos Space Network Management Platform Workspaces Feature Guide* (available at [http://www.juniper.net/documentation/en\\_US/release-independent/junos-space/index.html](http://www.juniper.net/documentation/en_US/release-independent/junos-space/index.html)).

Table 3 on page 7 summarizes the functions of Ethernet interfaces on the Junos Space Appliance.

**Table 3: Junos Space Appliance Ethernet Interfaces**

Interface	Function
<b>ETH0</b> or <b>3</b>	SSH and device management, if only the Ethernet interface <b>ETH0</b> or Ethernet interface <b>0</b> is used
<b>ETH0:0</b> or <b>3:0</b>	GUI interface
<b>ETH1</b> or <b>2</b>	SSH access to the Junos Space nodes  <b>NOTE:</b> SSH is disabled on the eth0 and eth3 interfaces when eth1 is configured.
<b>ETH2</b> or <b>1</b>	Reserved for future use

Table 3: Junos Space Appliance Ethernet Interfaces (*Continued*)

Interface	Function
<b>ETH3 or 0</b>	Device management when managed devices are on an out-of-band management subnet and not reachable by the Ethernet interface eth0

## RELATED DOCUMENTATION

[Troubleshooting Junos Space Ethernet Interface eth3 Connectivity | 181](#)

[Junos Space Appliance Overview | 2](#)

[Junos Space Appliance Overview](#)

[NTP Time Source for a Junos Space Appliance | 8](#)

[Configuring a Junos Space Appliance as a Junos Space Node | 97](#)

[Configuring a Junos Space Appliance as a Standalone or Primary FMPM Node | 123](#)

## NTP Time Source for a Junos Space Appliance

This topic applies to the following Junos Space Appliances: JA1500 and JA2500.

To ensure consistent behavior among all nodes in a multinode fabric, each node time must be synchronized with every other node in the fabric. When you configure a Junos Space Appliance with a Network Time Protocol (NTP) server, you ensure that if the first node, which is used to synchronize time for all nodes in the fabric, goes down, all other nodes in the fabric remain synchronized. To ensure this behavior, all nodes in a fabric must use the same external NTP source that you configure for the first appliance. The additional nodes installed on the same fabric automatically get their time setting from the first node in the fabric.

For more information about the Junos Space fabric, refer to the *Managing Nodes in the Junos Space Fabric* chapter in the *Junos Space Network Management Platform Workspaces Feature Guide* (available at [http://www.juniper.net/documentation/en\\_US/release-independent/junos-space/index.html](http://www.juniper.net/documentation/en_US/release-independent/junos-space/index.html)).

**NOTE:** By default, Junos Space Network Management Platform synchronizes the time zone of the client computer with that of the Junos Space server. Hence, the time displayed on the Web user interface corresponds to the time zone configured on the Junos Space server. However, the



Junos Space CLI displays the time corresponding to the time zone configured in the Junos Space server.

To ensure time synchronization across all nodes in the fabric, we strongly recommend that you use the following guidelines:

- Add an NTP server when you configure the first Junos Space node in the fabric.
- For each additional node that you add to the fabric, configure the same NTP server that you specified for the first appliance.

**NOTE:** You must add the NTP server *before* you add the first node to the fabric from the Junos Space Network Management Platform Web user interface.

## RELATED DOCUMENTATION

[Junos Space Appliance Overview | 2](#)

[Junos Space Appliance Overview](#)

[Junos Space Ethernet Interfaces Overview | 4](#)

[Configuring a Junos Space Appliance as a Junos Space Node | 97](#)

[Configuring a Junos Space Appliance as a Standalone or Primary FMPM Node | 123](#)

[Changing Network and System Settings for a Junos Space Appliance | 151](#)

# Chassis

## IN THIS CHAPTER

- [Chassis Physical Specifications for the JA2500 Appliance | 10](#)
- [Front Panel of a JA2500 Appliance | 11](#)
- [Rear Panel of a JA2500 Appliance | 13](#)
- [Chassis Console Port Pinouts | 14](#)

## Chassis Physical Specifications for the JA2500 Appliance

The JA2500 Junos Space Appliance chassis is a rigid sheet-metal structure that houses the appliance hardware components. [Table 4 on page 10](#) summarizes the physical specifications of the JA2500 appliance chassis.

**Table 4: Physical Specifications of the JA2500 Appliance Chassis**

Description	Value
Height	3.5 in (8.89 cm)
Width	17.31 in (44 cm)
Depth	17.81 in (45.2 cm)
Weight	28.05 lb (approximately 12.72 kg) with a single AC power supply installed

## RELATED DOCUMENTATION

[Front Panel of a JA2500 Appliance | 11](#)

## Front Panel of a JA2500 Appliance

The front panel of the JA2500 Junos Space Appliance, shown in [Figure 1 on page 11](#), consists of the components listed in [Table 5 on page 11](#).

Figure 1: JA2500 Appliance Front Panel

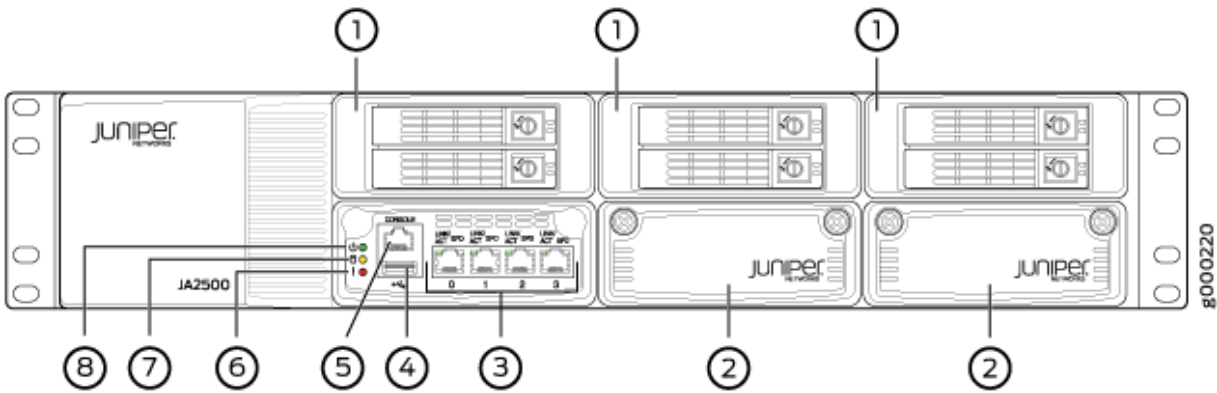

1– Hard drive	5– Console port
2– IOC expansion slot	6– Hardware Fault LED
3– Network (Ethernet) ports	7– Hard Disk Activity LED
4– USB port	8– Power LED

Table 5: JA2500 Appliance Front Panel Components

Component	Description
Hard drives	<p>The JA2500 appliance has six hot-swappable 1-TB hard disk drives in a RAID 10 configuration. The hard drives are numbered (0 through 5) as follows:</p> <ul style="list-style-type: none"> <li>Slot 3 (top left) and Slot 0 (bottom left)</li> <li>Slot 4 (top middle) and Slot 1 (bottom middle)</li> <li>Slot 5 (top right) and Slot 2 (bottom right)</li> </ul>

Table 5: JA2500 Appliance Front Panel Components (Continued)

Component	Description
I/O card (IOC) expansion slots	IOC expansion is currently not supported.
Network ports	Four RJ-45 Ethernet 10/100/1000 ports, labeled 0 through 3 from left to right
USB port	One USB port
Console port	One RJ-45 console port
Chassis LEDs	<p>The following chassis LEDs, located next to the console port, are present on the appliance:</p> <ul style="list-style-type: none"> <li>• Hardware Fault LED (red), which indicates that a fan, power supply, or temperature alarm has occurred.</li> <li>• Hard Disk Activity LED (yellow), which indicates that the hard disk is in use.</li> <li>• Power LED (green), which indicates that the appliance is powered on.</li> </ul>
Ethernet (LAN) port LEDs	<p>The following LEDs are present above each Ethernet port:</p> <ul style="list-style-type: none"> <li>• Link/Activity LED (green), which indicates the link (On) or link activity (Blinking)</li> <li>• Speed LED, which indicates the link speed: <ul style="list-style-type: none"> <li>• Off—10 Mbps</li> <li>• Green—100 Mbps</li> <li>• Yellow—1000 Mbps or 1 Gbps</li> </ul> </li> </ul>
Hard drive LEDs	<p>In addition to the LEDs on the appliance chassis, there are two LEDs on each hard disk:</p> <ul style="list-style-type: none"> <li>• Hard Disk Activity LED (green), which indicates disk activity</li> <li>• Hard Disk Failure LED (red), which indicates disk failure (On) or disk rebuilding (Blinking)</li> </ul>

**RELATED DOCUMENTATION**

[Rear Panel of a JA2500 Appliance | 13](#)

[Chassis Physical Specifications for the JA2500 Appliance | 10](#)

[Junos Space Appliance Overview | 2](#)

## Rear Panel of a JA2500 Appliance

The rear panel of the JA2500 Junos Space Appliance, shown in [Figure 2 on page 13](#), consists of the components listed in [Table 6 on page 13](#).

**Figure 2: JA2500 Rear Panel**

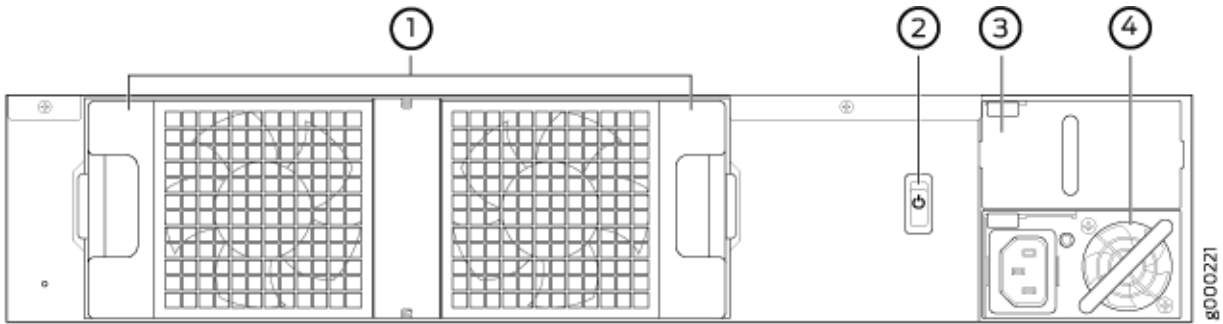

1– Cooling fans	3– Redundant power supply module slot
2– Power switch	4– Power supply module

**Table 6: JA2500 Appliance Rear Panel Components**

Component	Description
Cooling fans	The JA2500 appliance has two hot-swappable cooling fans that provide the required airflow to cool the appliance.
Power switch	The appliance power switch is used to power on or power off the appliance.

**Table 6: JA2500 Appliance Rear Panel Components (Continued)**

Component	Description
Redundant power supply module slot	An empty power supply module slot is provided so that a second power supply module can be added, for redundancy, if needed.
Power supply module	A single AC power supply module is shipped with the appliance and provides power to the appliance. However, the appliance can also be run on DC by using the DC power supply module for the JA2500 appliance.
Power Supply Module LED	One LED is present on the power supply module: <ul style="list-style-type: none"> <li>• Green indicates that the power supply module is powering the appliance.</li> <li>• Amber indicates that the power supply module is on but it is not powering the appliance (standby mode).</li> </ul>

**RELATED DOCUMENTATION**

[Front Panel of a JA2500 Appliance | 11](#)

[Chassis Physical Specifications for the JA2500 Appliance | 10](#)

[Junos Space Appliance Overview | 2](#)

**Chassis Console Port Pinouts**

This topic applies to the following Junos Space Appliances: JA1500 and JA2500.

[Table 7 on page 15](#) describes the details of RJ-45 chassis console port pinouts for the JA1500 and JA2500 appliances.

**Table 7: RJ-45 Console Connector Pinouts for Junos Space Appliances**

Pin	Signal	Description
1	RTS Output	Request to Send
2	DTR Output	Data Terminal Ready
3	TxD Output	Transmit Data
4	GND	Chassis Ground
5	GND	Chassis Ground
6	RxD Input	Receive Data
7	DSR Input	Data Set Ready
8	CTS Input	Clear to Send

**RELATED DOCUMENTATION**

[Connecting a Junos Space Appliance to a Management Console | 94](#)

[Connecting a Junos Space Appliance to the Network | 93](#)

[Front Panel of a JA1500 Appliance](#)

[Front Panel of a JA2500 Appliance | 11](#)

# 2

PART

## Site Planning and Specifications

---

Site Preparation | 17

Rack Requirements | 21

Power Requirements | 23

Compliance | 30

---



# Site Preparation

## IN THIS CHAPTER

- [General Site Guidelines for Junos Space Appliances | 17](#)
- [Site Electrical Wiring Guidelines | 18](#)
- [Environmental Requirements and Specifications for Junos Space Appliances | 19](#)

## General Site Guidelines for Junos Space Appliances

This topic applies to the following Junos Space Appliances: JA1500 and JA2500.

The following precautions can help you plan an acceptable operating environment for your Junos Space Appliance and avoid environmentally caused equipment failures:

- Keep the area around the chassis free from dust and conductive material, such as metal flakes.
- For the cooling system to function properly, the airflow around the chassis must be unrestricted. Allow sufficient clearance between the front and back of the chassis and adjacent equipment. Ensure that there is adequate circulation in the installation location.
- Follow the electrostatic discharge (ESD) procedures to avoid damaging the equipment. Static discharge can cause components to fail, either completely or intermittently over time.

**NOTE:** Install the appliance only in restricted areas, such as dedicated equipment rooms and equipment closets, in accordance with Articles 110–16, 110–17, and 110–18 of the National Electrical Code, ANSI/NFPA 70.

## RELATED DOCUMENTATION

[Environmental Requirements and Specifications for Junos Space Appliances | 19](#)

[General Electrical Safety Guidelines and Warnings | 65](#)

## Site Electrical Wiring Guidelines

This topic applies to the following Junos Space Appliances: JA1500 and JA2500.

Table 8 on page 18 describes the factors you must consider while planning the electrical wiring at your site.



**WARNING:** It is particularly important to provide a properly grounded and shielded environment and to use electrical surge-suppression devices.

**Table 8: Site Electrical Wiring Guidelines**

Site Wiring Factor	Guidelines
Signaling limitations	<p>If your site experiences any of the following problems, consult experts in electrical surge suppression and shielding:</p> <ul style="list-style-type: none"> <li>• Improperly installed wires cause radio frequency interference (RFI).</li> <li>• Damage from lightning strikes occurs when wires exceed recommended distances or pass between buildings.</li> <li>• Electromagnetic pulses (EMPs) caused by lightning damage unshielded conductors and electronic devices.</li> </ul>
Radio frequency interference	<p>To reduce or eliminate radio frequency interference (RFI) from your site wiring, do the following:</p> <ul style="list-style-type: none"> <li>• Use a twisted-pair cable with a good distribution of grounding conductors.</li> <li>• If you must exceed the recommended distances, use a high-quality twisted-pair cable with one ground conductor for each data signal when applicable.</li> </ul>

**Table 8: Site Electrical Wiring Guidelines (Continued)**

Site Wiring Factor	Guidelines
Electromagnetic compatibility	<p>If your site is susceptible to problems with electromagnetic compatibility (EMC), particularly from lightning or radio transmitters, seek expert advice.</p> <p>Some of the problems caused by strong sources of electromagnetic interference (EMI) are as follows:</p> <ul style="list-style-type: none"> <li>• Destruction of the signal drivers and receivers in the appliance.</li> <li>• Electrical hazards due to power surges conducted over the lines into the equipment.</li> </ul>

## RELATED DOCUMENTATION

[Environmental Requirements and Specifications for Junos Space Appliances | 19](#)

[General Electrical Safety Guidelines and Warnings | 65](#)

[General Safety Guidelines and Warnings | 39](#)

[General Site Guidelines for Junos Space Appliances | 17](#)

## Environmental Requirements and Specifications for Junos Space Appliances

This topic applies to the following Junos Space Appliances: JA1500 and JA2500.

The appliance must be installed in a rack housed in a dry, clean, well-ventilated, and temperature-controlled environment.

Ensure that the following environmental guidelines are followed:

- Keep the site as dust-free as possible because dust can clog air intake vents and filters, reducing the efficiency of the appliance cooling system.
- Maintain ambient airflow for normal appliance operation. If the airflow is blocked or restricted, or if the intake air is too warm, the appliance might overheat.

[Table 9 on page 20](#) provides the required environmental conditions for normal appliance operation and [Table 10 on page 20](#) the environmental specifications for storing the appliance (nonoperational).

**Table 9: Environmental Specifications for Appliance Operation**

Description	Tolerance
Altitude	No performance degradation upto 10,000 ft (3048 m)
Relative humidity	Normal operation ensured in the relative humidity range of 8% to 90%, noncondensing
Temperature	Normal operation ensured in the temperature range of 41° F to 104° F (5° C to 40° C)

**Table 10: Environmental Specifications for Appliance Storage**

Description	Tolerance
Altitude	The appliance can be stored safely upto 40,000 ft (12,192 m)
Relative humidity	The appliance can be stored safely in the relative humidity range of 5% to 95%, noncondensing
Temperature	The appliance can be stored safely in the temperature range of -40° F to 158° F (-40° C to 70° C)

**RELATED DOCUMENTATION**

[General Safety Guidelines and Warnings | 39](#)

[General Site Guidelines for Junos Space Appliances | 17](#)

# Rack Requirements

## IN THIS CHAPTER

- Junos Space Appliance Rack Requirements | 21

## Junos Space Appliance Rack Requirements

This topic applies to the following Junos Space Appliances: JA1500 and JA2500.

The Junos Space Appliance can be installed in a rack. Many types of racks are acceptable, including front-mount racks and two-post (telco) racks.

[Table 11 on page 21](#) provides the details of requirements for rack size, clearance, airflow, spacing of mounting brackets and flange holes, and connecting to the building structure.

**Table 11: Rack Requirements for the Junos Space Appliance**

Rack Requirement	Specifications
Size	<p>A 19-in. (48.3-cm) rack as defined in Cabinets, Racks, Panels, and Associated Equipment (document number EIA-310-D) published by the Electronic Components Industry Association (<a href="http://www.ecianow.org">http://www.ecianow.org</a>).</p> <p>A 600-mm rack as defined in the four-part Equipment Engineering (EE); European telecommunications standard for equipment practice (document numbers ETS 300 119-1 through 119-4) published by the European Telecommunications Standards Institute (<a href="http://www.etsi.org">http://www.etsi.org</a>).</p> <p>The horizontal spacing between the rails in a rack that complies with this standard is wider than the appliance's mounting brackets, which measure 19 in. (48.3 cm) from outer edge to outer edge. Use approved wing devices to narrow the opening between the rails as required.</p>

**Table 11: Rack Requirements for the Junos Space Appliance (Continued)**

Rack Requirement	Specifications
Clearance	<ul style="list-style-type: none"> <li>The outer edges of the mounting brackets extend the width of either chassis to 19 in. (48.3 cm).</li> <li>The front of the chassis extends approximately 0.5 in. (1.27 cm) beyond the mounting ears.</li> </ul>
Spacing of mounting bracket and flange holes	<ul style="list-style-type: none"> <li>The holes within each rack set are spaced at 2-U [3.5 in (8.9 cm)]. Therefore, the appliance can be mounted in a rack that provides holes or hole patterns spaced at 2-U [3.5 in (8.9 cm)] increments, or in a rack that provides holes or hole patterns spaced at 1-U [1.75 in. (4.5 cm)] increments as long as there is 2x1-U space available in the rack.</li> <li>The mounting brackets and front-mount flanges used to attach the chassis to a rack are designed to fasten to holes spaced at rack distances of 2-U [3.5 in (8.9 cm)] increments, or in a rack that provides holes or hole patterns spaced at 1-U [1.75 in. (4.5 cm)] increments as long as there is 2x1-U space available in the rack.</li> <li>The mounting holes in the mounting brackets provided with the device are spaced 1.25 in. (3.2 cm) apart (top and bottom mounting holes).</li> </ul>
Connecting to the building structure	<p>Always secure the rack in which you are installing the appliance to the structure of the building. If your geographical area is subject to earthquakes, bolt the rack to the floor. For maximum stability, also secure the rack to ceiling brackets.</p>

**RELATED DOCUMENTATION**

[Mounting the JA2500 Junos Space Appliance | 83](#)

[Rack-Mounting Warnings | 53](#)

[Tools and Parts Required to Install the Junos Space Appliance | 81](#)

# Power Requirements

## IN THIS CHAPTER

- AC Power Cord Specifications for Junos Space Appliances | 23
- AC Power Supply in Junos Space Appliances | 25
- DC Power Supply in Junos Space Appliances | 27

## AC Power Cord Specifications for Junos Space Appliances

This topic applies to the following Junos Space Appliances: JA1500 and JA2500.

The Junos Space Appliance is shipped with a pre-installed AC power supply module. A power cord suitable for your region is shipped along with the Junos Space Appliance.

The coupler is type C13 as described by International Electrotechnical Commission (IEC) standard 60320. The plug end of the power cord fits into the power source outlet that is standard for your geographical location.



**CAUTION:** The AC power cord provided with each power supply module is intended only for use with that power supply module and not for any other use.

**NOTE:** In North America, AC power cords must not exceed 4.5 meters (approximately 14.76 feet) in length to comply with National Electrical Code (NEC) Sections 400-8 (NFPA 75, 5-2.2) and 210-52 and Canadian Electrical Code (CEC) Section 4-010(3). The cords supplied with the appliance are in compliance.

Table 12 on page 24 lists AC power cord specifications provided for each country or region.

**Table 12: AC Power Cord Specifications**

Country or Region	Electrical Specifications	Plug Standards	Juniper Model Number
Australia	250 VAC, 10 A, 50 Hz	AS/NZS 3112-1993	CBL-JX-PWR-AU
China	250 VAC, 10 A, 50 Hz	GB 2009/GB 1002-1996	CBL-JX-PWR-CH
Europe (except Italy, Switzerland, and United Kingdom)	250 VAC, 10 A, 50 Hz	CEE (7) VII	CBL-JX-PWR-EU
Italy	250 VAC, 10 A, 50 Hz	CEI 23-50	CBL-JX-PWR-IT
Japan	125 VAC, 12 A, 50 Hz or 60 Hz	JIS 8303	CBL-JX-PWR-JP
Korea	250 VAC, 10 A, 60 Hz	CEE (7) VII	CBL-JX-PWR-KR
Switzerland	250 VAC, 10 A, 50 Hz	SEV 1011 SEV 6534/2	CBL-EX-PWR-C13-SZ
United Kingdom	250 VAC, 10 A, 50 Hz	BS 1363/A	CBL-JX-PWR-UK
United States	125 VAC, 10 A, 60 Hz	NEMA 5-15	CBL-JX-PWR-US

Figure 3 on page 24 illustrates the plug on the power cord for some of the countries or regions listed in Table 12 on page 24.

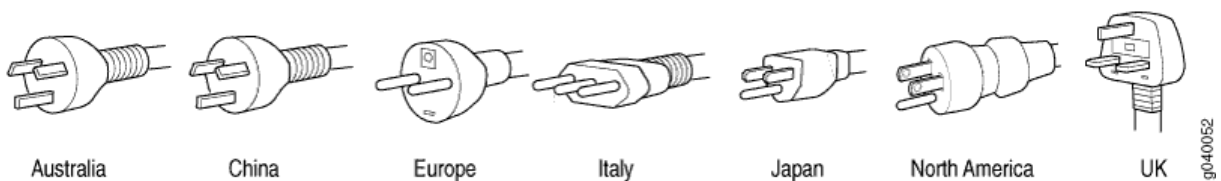
**Figure 3: AC Plug Types**



## RELATED DOCUMENTATION

[AC Power Electrical Safety Guidelines | 68](#)

[AC Power Supply in Junos Space Appliances | 25](#)

[Replacing the AC Power Supply Cord on a Junos Space Appliance | 162](#)

## AC Power Supply in Junos Space Appliances

This topic applies to the following Junos Space Appliances: JA1500 and JA2500.

A Junos Space Appliance ships with a single AC power supply module, shown in [Figure 4 on page 25](#). An additional AC power supply module can be installed to provide redundancy.

**NOTE:** While it is possible to provide redundancy in the Junos Space Appliance using a combination of AC and DC power supply modules, we recommend that you *do not* provide redundancy in this manner. Instead, use two AC power supply modules or two DC power supply modules if you want to provide redundancy.

**Figure 4: AC Power Supply Module**

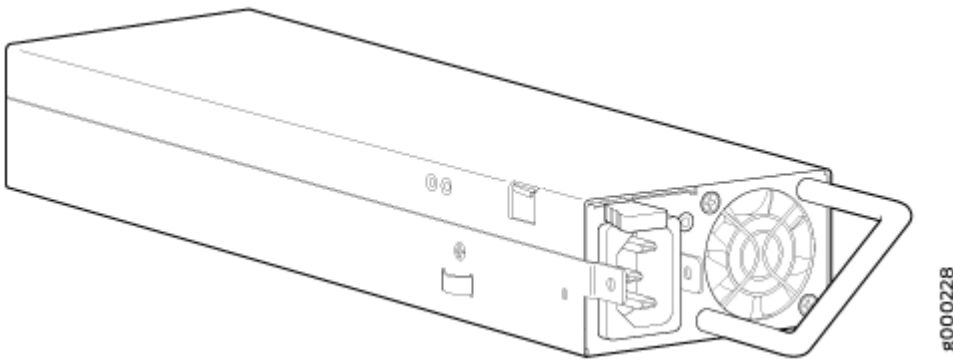

[Table 13 on page 25](#) shows details of the AC power supply module for a Junos Space Appliance.

**Table 13: Details of an AC Power Supply Module**

Item	Details
Model number	UNIV-250W-PS-AC

Table 13: Details of an AC Power Supply Module *(Continued)*

Item	Details
Field replaceable unit type	<p>Cold-swappable, if the appliance has only one power supply module</p> <p>Hot-swappable, if the appliance has an additional redundant, functioning power supply module that is plugged into a separate power circuit</p>
Power supply module weight	2.05 lb. (0.93 kg)
Fans	One internal fan per power supply module
Airflow	From the front of the chassis to the back
Power Supply Module (Status) LED	<p>One Power Supply Module LED present on the power supply faceplate:</p> <ul style="list-style-type: none"> <li>• Green indicates that the power supply module is working properly; the module is powered on and is powering the appliance.</li> <li>• Amber indicates that the power supply module is in standby mode; the module is powered on but it is not powering the appliance.</li> <li>• Off indicates that the power supply module is not powered on or that the module is not working properly.</li> </ul>
AC Input Voltage	100 to 240 VAC
AC Input Line Frequency	50 to 60 Hz
Peak Inrush Current	<ul style="list-style-type: none"> <li>• 40 A maximum at 115 VAC and 77° F (25° C)</li> <li>• 80 A maximum at 240 VAC and 77° F (25° C)</li> </ul>
Maximum Output Power	250 W
Power Module Maximum Efficiency	80Plus 250 W AC

## RELATED DOCUMENTATION

[AC Power Electrical Safety Guidelines | 68](#)

[Connecting AC Power to the Junos Space Appliance | 88](#)

[Replacing the AC Power Supply Module on a Junos Space Appliance | 164](#)

## DC Power Supply in Junos Space Appliances

This topic applies to the following Junos Space Appliances: JA1500 and JA2500.

A Junos Space Appliance ships with a single AC power supply module. However, you can use a DC power supply, shown in [Figure 5 on page 27](#), to power the appliance.

**NOTE:** While it is possible to provide redundancy in the Junos Space Appliance using a combination of AC and DC power supply modules, we recommend that you *do not* provide redundancy in this manner. Instead, use two DC power supply modules or two AC power supply modules if you want to provide redundancy.

**Figure 5: DC Power Supply Module**

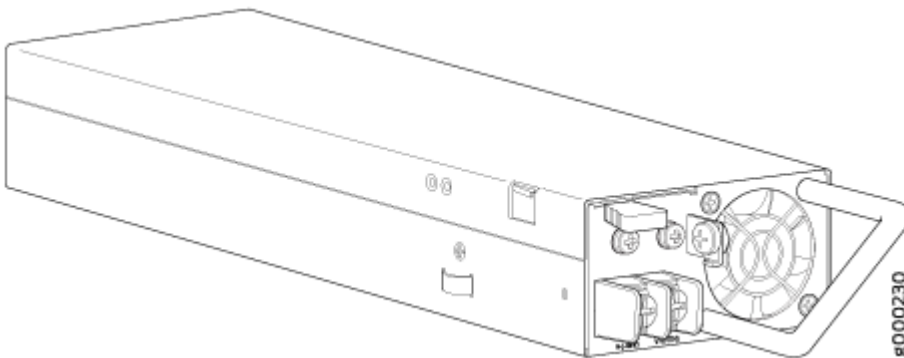

[Table 14 on page 27](#) shows details of the DC power supply module for a Junos Space Appliance.

**Table 14: Details of a DC Power Supply Module**

Item	Details
Model number	UNIV-560W-PS-DC

Table 14: Details of a DC Power Supply Module *(Continued)*

Item	Details
Field-Replaceable Unit type	<p>Cold-swappable, if the appliance has only one power supply module</p> <p>Hot-swappable, if the appliance has an additional redundant, functioning power supply module that is plugged into a separate power circuit</p>
Power supply weight	2.60 lb (1.18 kg)
Fans	One internal fan per power supply module
Airflow	From the front of the chassis to the back
Power Supply Module (Status) LED	<p>One Power Supply Module LED present on the power supply faceplate:</p> <ul style="list-style-type: none"> <li>• Green indicates that the power supply module is working properly; the module is powered on and is powering the appliance.</li> <li>• Amber indicates that the power supply module is in standby mode; the module is powered on but it is not powering the appliance.</li> <li>• Off indicates that the power supply module is not powered on or that the module is not working properly.</li> </ul>
Maximum Output Power	560 W
DC Maximum Current	20 A
DC Power Module	-45 V to -60 V
DC Power Supply Peak inrush	< 60 A
Power Module Maximum Efficiency	80Plus 560 W cDC

## RELATED DOCUMENTATION

[DC Power Electrical Safety Guidelines | 71](#)

---

[Connecting DC Power to the Junos Space Appliance | 90](#)

---

[Replacing the DC Power Supply Cable on a Junos Space Appliance | 167](#)

---

[Replacing the DC Power Supply Module on a Junos Space Appliance | 169](#)

# Compliance

## IN THIS CHAPTER

- Agency Approvals for JA2500 | 30
- Compliance Statements for EMC Requirements for JA2500 | 32
- Compliance Statements for Acoustic Noise for JA2500 | 34
- Declaration of Conformity for JA2500 Junos Space Appliance | 36

## Agency Approvals for JA2500

### IN THIS SECTION

- Compliance Statement for Argentina | 31

The Junos Space JA2500 appliance complies with the following standards:

- Safety
  - CAN/CSA-C22.2 No. 60950-1 (2007) Information Technology Equipment
  - UL 60950-1 (2nd Ed.) Information Technology Equipment
  - EN 60950-1 (2006) Information Technology Equipment
  - IEC 60950-1 (2005) Information Technology Equipment
  - EN 60825-1 (2007) Safety of Laser Products - Part 1: Equipment classification and requirements
- EMC
  - FCC 47CFR Part 15 Class A (USA)

- EN 55022 Class A Emissions (Europe)
- ICES-003 Class A
- VCCI Class A (Japan)
- AS/NZS CISPR 22 Class A (Australia/New Zealand)
- CISPR 22 Class A
- EN 55024
- EN 300386
- EN 61000-3-2 Power Line Harmonics
- EN 61000-3-3 Voltage Fluctuations and Flicker
- EN 61000-4-2 ESD
- EN 61000-4-3 Radiated Immunity
- EN 61000-4-4 EFT
- EN 61000-4-5 Surge
- EN 61000-4-6 Low Frequency Common Immunity
- EN 61000-4-11 Voltage Dips and Sags

## Compliance Statement for Argentina

EQUIPO DE USO IDÓNEO.

### RELATED DOCUMENTATION

[Compliance Statements for EMC Requirements for JA2500 | 32](#)

[Compliance Statements for Acoustic Noise for JA2500 | 34](#)

## Compliance Statements for EMC Requirements for JA2500

### IN THIS SECTION

- [Canada | 32](#)
- [European Community | 33](#)
- [Japan | 33](#)
- [Korea | 33](#)
- [United States | 34](#)
- [FCC Part 15 Statement | 34](#)

This topic describes the electromagnetic compatibility (EMC) requirements for the Junos Space JA2500 appliance:

### Canada

This Class A digital apparatus complies with Canadian ICES-003.

Cet appareil numérique de la classe A est conforme à la norme NMB-003 du Canada.

The Industry Canada label identifies certified equipment. This certification means that the equipment meets certain telecommunications network protective, operational, and safety requirements. Industry Canada does not guarantee the equipment will operate to the users' satisfaction.

Before installing this equipment, users should ensure that it is permissible to connect the equipment to the facilities of the local telecommunications company. The equipment must also be installed using an acceptable method of connection. In some cases, the inside wiring associated with a single line individual service can be extended by means of a certified connector assembly. The customer should be aware that compliance with the above conditions might not prevent degradation of service in some situations.

Repairs to certified equipment should be made by an authorized Canadian maintenance facility designated by the supplier. Any repairs or alterations made by the user to this equipment, or equipment malfunctions, might give the telecommunications company cause to request the user to disconnect the equipment.





**CAUTION:** Users should not attempt to make electrical ground connections by themselves, but should contact the appropriate inspection authority or an electrician, as appropriate.

Users should ensure for their own protection that the electrical ground connections of the power utility, telephone lines, and internal metallic water pipe system, if present, are connected together. This precaution might be particularly important in rural areas.

## European Community

This is a Class A device. In a domestic environment this device might cause radio interference, in which case the user needs to take adequate measures.

## Japan

この装置は、クラス A 情報技術装置です。この装置を家庭環境で使用すると電波妨害を引き起こすことがあります。この場合には使用者が適切な対策を講ずるよう要求されることがあります。 VCCI-A

The preceding translates as follows:

This is a Class A device. In a domestic environment this device might cause radio interference, in which case the user needs to take adequate measures.

VCCI-A

## Korea

이 기기는 업무용(A급) 전자파적합기기로서 판매자 또는 사용자는 이 점을 주의하시기 바라며, 가정외의 지역에서 사용하는 것을 목적으로 합니다.

Korean Class A Warning

g040913

The preceding translates as follows:

This equipment is Industrial (Class A) electromagnetic wave suitability equipment and the seller or user should take notice of it, and this equipment is to be used in places other than the home

## United States

The device has been tested and found to comply with the limits for a Class A digital device, pursuant to Part 15 of the FCC Rules. These limits are designed to provide reasonable protection against harmful interference when the equipment is operated in a commercial environment. This equipment generates, uses, and can radiate radio frequency energy and, if not installed and used in accordance with the instruction manual, might cause harmful interference to radio communications. Operation of this equipment in a residential area is likely to cause harmful interference, in which case users need to correct the interference at their own expense.

### FCC Part 15 Statement

This equipment has been tested and found to comply with the limits for a Class A digital device pursuant to Part 15 of the FCC Rules. These limits are designed to provide reasonable protection against harmful interference in a residential installation. This equipment generates, uses, and can radiate radio frequency energy and, if not installed and used in accordance with the instructions, might cause harmful interference to radio communications. However, there is no guarantee that interference will not occur in a particular installation.

If this equipment does cause harmful interference to radio or television reception, which can be determined by turning the equipment off and on, the user is encouraged to try and correct the interference by one or more of the following measures:

- Reorient or relocate the receiving antenna.
- Increase the separation between the equipment and the receiver.
- Connect the equipment into an outlet on a circuit different from that to which the receiver is connected.
- Consult the dealer or an experienced radio or TV technician for help.

### RELATED DOCUMENTATION

[Agency Approvals for JA2500 | 30](#)

[Compliance Statements for Acoustic Noise for JA2500 | 34](#)

## Compliance Statements for Acoustic Noise for JA2500

This topic applies to the Junos Space JA2500 appliance.

Maschinenlärminformations-Verordnung - 3. GPSGV, der höchste Schalldruckpegel beträgt 70 dB(A) oder weniger gemäss EN ISO 7779

Translation:

The emitted sound pressure is below 70 dB(A) per EN ISO 7779.

## RELATED DOCUMENTATION

[Agency Approvals for JA2500 | 30](#)

[Compliance Statements for EMC Requirements for JA2500 | 32](#)

# Declaration of Conformity for JA2500 Junos Space Appliance



## Declaration of Conformity



Juniper Networks, Inc.  
1194 N. Mathilda Ave  
Sunnyvale, CA 94089 USA

declares under our sole responsibility that the product:

**JA2500**  
**Network Appliance**

Conforms with the provisions of the following EC Directives, including all amendments,  
and with national legislation implementing these directives:

**Low Voltage Directive 2006/95/EC**  
**EMC Directive 2004/108/EC**

The following harmonized standards were applied:

<b>EMC</b>	<b>EN 300 386 v1.5.1: 2010</b> <b>EN 55022: 2010, Class A</b> <b>EN55024: 2010</b>
<b>Safety</b>	<b>EN 60950-1: 2006 + A12: 2011</b>

Said Product complies with Directive 2011/65/EC (RoHS2) Restriction on Hazardous Substances

This product carries the CE Mark, which was first affixed in 2013.

Place  
**Sunnyvale, CA**

Signature

Date  
**3/21/2014**

**Michael J. Azar**  
**Homologation Manager**  
1194 N. Mathilda Ave  
Sunnyvale, CA 94089 USA

## RELATED DOCUMENTATION

[Agency Approvals for JA2500 | 30](#)

---

[Compliance Statements for Acoustic Noise for JA2500 | 34](#)

---

[Compliance Statements for EMC Requirements for JA2500 | 32](#)

# 3

PART

## Safety and Regulatory Compliance Information

---

General Safety Information | 39

Radiation and Laser Warnings | 46

Installation and Maintenance Safety Information | 51

Power and Electrical Safety Information | 65

---

# General Safety Information

## IN THIS CHAPTER

- General Safety Guidelines and Warnings | 39
- Definitions of Safety Warning Levels | 40
- Fire Safety Requirements | 42
- Qualified Personnel Warning | 43
- Warning Statement for Norway and Sweden | 44

## General Safety Guidelines and Warnings

The following guidelines help ensure your safety and protect the appliance from damage. The list of guidelines might not address all potentially hazardous situations in your working environment, so we recommend that you be alert and exercise good judgment at all times.

- Perform only the procedures explicitly described in the hardware documentation for this product. Make sure that only authorized service personnel perform other system services.
- Keep the area around the chassis clear and free from dust before, during, and after installation.
- Keep tools away from areas where people could trip over them while walking.
- Do not wear loose clothing or jewelry, such as rings, bracelets, or chains, which can get caught in the chassis.
- Wear safety glasses if you are working under any conditions that could be hazardous to your eyes.
- Do not perform any actions that create a potential hazard to people or make the equipment unsafe.
- Never attempt to lift an object that is too heavy for one person to handle.
- Never install or manipulate wiring during electrical storms.
- Never install electrical jacks in wet locations unless the jacks are specifically designed for wet environments.

- Operate the appliance only when it is properly grounded.
- Ensure that the separate protective earthing terminal provided on this product is permanently connected to earth.
- Replace fuses only with fuses of the same type and rating.
- Do not open or remove chassis covers or sheet-metal parts unless instructions are provided in the hardware documentation for this product. Such an action could cause severe electrical shock.
- Do not push or force any objects through any opening in the chassis frame. Such an action could result in electrical shock or fire.
- Avoid spilling liquid on the appliance. Such an action could cause electrical shock or damage the appliance.
- Avoid touching uninsulated electrical wires or terminals that are not disconnected from their power source. Such an action can cause electrical shock.
- Always ensure that all modules, power supplies, and blanks are fully inserted and that the installation screws are fully tightened.

## RELATED DOCUMENTATION

[AC Power Electrical Safety Guidelines | 68](#)

[DC Power Electrical Safety Guidelines | 71](#)

[General Electrical Safety Guidelines and Warnings | 65](#)

[Grounded Equipment Warning | 58](#)

[Installation Instructions Warning | 51](#)

[Maintenance and Operational Safety Guidelines and Warnings | 59](#)

## Definitions of Safety Warning Levels

The documentation uses the following levels of safety warnings (there are two “Warning” formats):

**NOTE:** You might find this information helpful in a particular situation, or you might overlook this important information if it was not highlighted in a Note.





**CAUTION:** You need to observe the specified guidelines to avoid minor injury or discomfort to you or severe damage to the device.



**LASER WARNING:** This symbol alerts you to the risk of personal injury from a laser.



**WARNING:** This symbol means danger. You are in a situation that could cause bodily injury. Before you work on any equipment, be aware of the hazards involved with electrical circuitry and be familiar with standard practices for preventing accidents.

**Waarschuwing** Dit waarschuwingssymbool betekent gevaar. U verkeert in een situatie die lichamelijk letsel kan veroorzaken. Voordat u aan enige apparatuur gaat werken, dient u zich bewust te zijn van de bij elektrische schakelingen betrokken risico's en dient u op de hoogte te zijn van standaard maatregelen om ongelukken te voorkomen.

**Varoitus** Tämä varoitusmerkki merkitsee vaaraa. Olet tilanteessa, joka voi johtaa ruumiinvammaan. Ennen kuin työskentelet minkään laitteiston parissa, ota selvää sähkökytkentöihin liittyvistä vaaroista ja tavanomaisista onnettomuuksien ehkäisykeinoista.

**Attention** Ce symbole d'avertissement indique un danger. Vous vous trouvez dans une situation pouvant causer des blessures ou des dommages corporels. Avant de travailler sur un équipement, soyez conscient des dangers posés par les circuits électriques et familiarisez-vous avec les procédures couramment utilisées pour éviter les accidents.

**Warnung** Dieses Warnsymbol bedeutet Gefahr. Sie befinden sich in einer Situation, die zu einer Körperverletzung führen könnte. Bevor Sie mit der Arbeit an irgendeinem Gerät beginnen, seien Sie sich der mit elektrischen Stromkreisen verbundenen Gefahren und der Standardpraktiken zur Vermeidung von Unfällen bewusst.

**Avvertenza** Questo simbolo di avvertenza indica un pericolo. La situazione potrebbe causare infortuni alle persone. Prima di lavorare su qualsiasi apparecchiatura, occorre conoscere i pericoli relativi ai circuiti elettrici ed essere al corrente delle pratiche standard per la prevenzione di incidenti.

**Advarsel** Dette varselsymbolet betyr fare. Du befinner deg i en situasjon som kan føre til personskade. Før du utfører arbeid på utstyr, må du være oppmerksom på de faremomentene som elektriske kretser innebærer, samt gjøre deg kjent med vanlig praksis når det gjelder å unngå ulykker.

**Aviso** Este símbolo de aviso indica perigo. Encontra-se numa situação que lhe poderá causar danos físicos. Antes de começar a trabalhar com qualquer equipamento, familiarize-se com os perigos relacionados com circuitos eléctricos, e com quaisquer práticas comuns que possam prevenir possíveis acidentes.

**¡Atención!** Este símbolo de aviso significa peligro. Existe riesgo para su integridad física. Antes de manipular cualquier equipo, considerar los riesgos que entraña la corriente eléctrica y familiarizarse con los procedimientos estándar de prevención de accidentes.

**Warning!** Denna varningssymbol signalerar fara. Du befinner dig i en situation som kan leda till personskada. Innan du utför arbete på någon utrustning måste du vara medveten om farorna med elkretsar och känna till vanligt förfarande för att förebygga skador.

## RELATED DOCUMENTATION

[General Safety Guidelines and Warnings | 39](#)

[Grounded Equipment Warning | 58](#)

[Installation Instructions Warning | 51](#)

[Laser and LED Safety Guidelines and Warnings for Junos Space Appliances | 47](#)

[Maintenance and Operational Safety Guidelines and Warnings | 59](#)

[Warning Statement for Norway and Sweden | 44](#)

## Fire Safety Requirements

In the event of a fire emergency involving appliances and other network equipment, the safety of people is the primary concern. You should establish procedures for protecting people in the event of a fire emergency, provide safety training, and properly provision fire-control equipment and fire extinguishers.

In addition, you should establish procedures to protect your equipment in the event of a fire emergency. Juniper Networks products should be installed in an environment suitable for electronic equipment. We recommend that fire suppression equipment be available in the event of a fire in the vicinity of the equipment and that all local fire, safety, and electrical codes and ordinances be observed when you install and operate your equipment.

### Fire Suppression

In the event of an electrical hazard or an electrical fire, you should first turn power off to the equipment at the source. Then use a Type C fire extinguisher, which uses noncorrosive fire retardants, to extinguish the fire.

### Fire Suppression Equipment

Type C fire extinguishers, which use noncorrosive fire retardants such as carbon dioxide and Halotron™, are most effective for suppressing electrical fires. Type C fire extinguishers displace oxygen from the point of combustion to eliminate the fire. For extinguishing fire on or around equipment that draws air from the environment for cooling, you should use this type of inert oxygen displacement extinguisher instead of an extinguisher that leaves residues on equipment.

Do not use multipurpose Type ABC chemical fire extinguishers (dry chemical fire extinguishers). The primary ingredient in these fire extinguishers is monoammonium phosphate, which is very sticky and difficult to clean. In addition, in the presence of minute amounts of moisture, monoammonium phosphate can become highly corrosive and corrode most metals.

Any equipment in a room in which a chemical fire extinguisher has been discharged is subject to premature failure and unreliable operation. The equipment is considered to be irreparably damaged.

**NOTE:** To keep warranties effective, do not use a dry chemical fire extinguisher to control a fire at or near a Junos Space appliance or other network device provided by Juniper Networks. If a dry chemical fire extinguisher is used, the unit is no longer eligible for coverage under a service agreement.

We recommend that you dispose of any irreparably damaged equipment in an environmentally responsible manner.

### RELATED DOCUMENTATION

[Action to Take After an Electrical Accident | 79](#)

[General Electrical Safety Guidelines and Warnings | 65](#)

[General Safety Guidelines and Warnings | 39](#)

## Qualified Personnel Warning



**WARNING:** Only trained and qualified personnel should install or replace the device.

**Waarschuwing** Installatie en reparaties mogen uitsluitend door getraind en bevoegd personeel uitgevoerd worden.

**Varoitus** Ainoastaan koulutettu ja pätevä henkilökunta saa asentaa tai vaihtaa tämän laitteen.

**Attention** Tout installation ou remplacement de l'appareil doit être réalisé par du personnel qualifié et compétent.

**Warnung** Gerät nur von geschultem, qualifiziertem Personal installieren oder auswechseln lassen.

**Avvertenza** Solo personale addestrato e qualificato deve essere autorizzato ad installare o sostituire questo apparecchio.

**Advarsel** Kun kvalifisert personell med riktig opplæring bør montere eller bytte ut dette utstyret.

**Aviso** Este equipamento deverá ser instalado ou substituído apenas por pessoal devidamente treinado e qualificado.

**¡Atención!** Estos equipos deben ser instalados y reemplazados exclusivamente por personal técnico adecuadamente preparado y capacitado.

**Varning!** Denna utrustning ska endast installeras och bytas ut av utbildad och kvalificerad personal.

## RELATED DOCUMENTATION

[AC Power Electrical Safety Guidelines | 68](#)

[DC Power Electrical Safety Guidelines | 71](#)

[General Electrical Safety Guidelines and Warnings | 65](#)

[General Safety Guidelines and Warnings | 39](#)

## Warning Statement for Norway and Sweden



**WARNING:** The equipment must be connected to an earthed mains socket-outlet.

**Advarsel** Apparatet skal kobles til en jordnet stikkontakt.

**Varning!** Apparaten skall anslutas till jordat nätuttag.

#### RELATED DOCUMENTATION

[General Safety Guidelines and Warnings | 39](#)

[Definitions of Safety Warning Levels | 40](#)

## Radiation and Laser Warnings

### IN THIS CHAPTER

- Radiation from Open Port Apertures Warning | 46
- Laser and LED Safety Guidelines and Warnings for Junos Space Appliances | 47

### Radiation from Open Port Apertures Warning



**LASER WARNING:** Because invisible radiation might be emitted from the aperture of the port when no fiber cable is connected, avoid exposure to radiation and do not stare into open apertures.

**Waarschuwing** Aangezien onzichtbare straling vanuit de opening van de poort kan komen als er geen fiberkabel aangesloten is, dient blootstelling aan straling en het kijken in open openingen vermeden te worden.

**Varoitus** Koska portin aukosta voi emittoitua näkymätöntä säteilyä, kun kuitukaapelia ei ole kytkettyä, vältä säteilylle altistumista äläkä katso avoimiin aukkoihin.

**Attention** Des radiations invisibles à l'il nu pouvant traverser l'ouverture du port lorsqu'aucun câble en fibre optique n'y est connecté, il est recommandé de ne pas regarder fixement l'intérieur de ces ouvertures.

**Warnung** Aus der Port-Öffnung können unsichtbare Strahlen emittieren, wenn kein Glasfaserkabel angeschlossen ist. Vermeiden Sie es, sich den Strahlungen auszusetzen, und starren Sie nicht in die Öffnungen!

**Avvertenza** Quando i cavi in fibra non sono inseriti, radiazioni invisibili possono essere emesse attraverso l'apertura della porta. Evitate di esporvi alle radiazioni e non guardate direttamente nelle aperture.

**Advarsel** Unngå utsettelse for stråling, og stirr ikke inn i åpninger som er åpne, fordi usynlig stråling kan emitteres fra portens åpning når det ikke er tilkoblet en fiberkabel.

**Aviso** Dada a possibilidade de emissão de radiação invisível através do orifício da via de acesso, quando esta não tiver nenhum cabo de fibra conectado, deverá evitar a exposição à radiação e não deverá olhar fixamente para orifícios que se encontrarem a descoberto.

**¡Atención!** Debido a que la apertura del puerto puede emitir radiación invisible cuando no existe un cable de fibra conectado, evite mirar directamente a las aperturas para no exponerse a la radiación.

**Warning!** Osynlig strålning kan avges från en portöppning utan ansluten fiberkabel och du bör därför undvika att bli utsatt för strålning genom att inte stirra in i oskyddade öppningar.

## RELATED DOCUMENTATION

[General Safety Guidelines and Warnings | 39](#)

[Grounded Equipment Warning | 58](#)

[Installation Instructions Warning | 51](#)

[Laser and LED Safety Guidelines and Warnings for Junos Space Appliances | 47](#)

## Laser and LED Safety Guidelines and Warnings for Junos Space Appliances

### IN THIS SECTION

- [General Laser Safety Guidelines | 48](#)
- [Class 1 Laser Product Warning | 48](#)
- [Class 1 LED Product Warning | 48](#)
- [Laser Beam Warning | 49](#)

Observe the following guidelines and warnings:

## General Laser Safety Guidelines

When working around ports that support optical transceivers, observe the following safety guidelines to prevent eye injury:

- Do not look into unterminated ports or at fibers that connect to unknown sources.
- Do not examine unterminated optical ports with optical instruments.
- Avoid direct exposure to the beam.



**LASER WARNING:** Unterminated optical connectors can emit invisible laser radiation. The lens in the human eye focuses all the laser power on the retina, so focusing the eye directly on a laser source—even a low-power laser—could permanently damage the eye.

## Class 1 Laser Product Warning



**LASER WARNING:** Class 1 laser product.

**Waarschuwing** Klasse-1 laser produkt.

**Varoitus** Luokan 1 lasertuote.

**Attention** Produit laser de classe I.

**Warnung** Laserprodukt der Klasse 1.



**LASER WARNING:** Avvertenza Prodotto laser di Classe 1.

**Advarsel** Laserprodukt av klasse 1.

**Aviso** Produto laser de classe 1.

**¡Atención!** Producto láser Clase I.

**Varning!** Laserprodukt av klass 1.

## Class 1 LED Product Warning





**LASER WARNING:** Class 1 LED product.

**Waarschuwing** Klasse 1 LED-product.

**Varoitus** Luokan 1 valodiodituote.

**Attention** Alarme de produit LED Class I.

**Warnung** Class 1 LED-Produktwarnung.



**LASER WARNING: Avvertenza** Avvertenza prodotto LED di Classe 1.

**Advarsel** LED-produkt i klasse 1.

**Aviso** Produto de classe 1 com LED.

**¡Atención!** Aviso sobre producto LED de Clase 1.

**Varning!** Lysdiodprodukt av klass 1.

## Laser Beam Warning



**LASER WARNING:** Do not stare into the laser beam or view it directly with optical instruments.



**LASER WARNING: Waarschuwing** Niet in de straal staren of hem rechtstreeks bekijken met optische instrumenten.



**LASER WARNING: Varoitus** Älä katso säteeseen äläkä tarkastele sitä suoraan optisen laitteen avulla.



**LASER WARNING: Attention** Ne pas fixer le faisceau des yeux, ni l'observer directement à l'aide d'instruments optiques.



**LASER WARNING: Warnung** Nicht direkt in den Strahl blicken und ihn nicht direkt mit optischen Geräten prüfen.



**LASER WARNING: Avvertenza** Non fissare il raggio con gli occhi né usare strumenti ottici per osservarlo direttamente.



**LASER WARNING: Advarsel** Stirr eller se ikke direkte p strlen med optiske instrumenter.



**LASER WARNING: Aviso** Não olhe fixamente para o raio, nem olhe para ele directamente com instrumentos ópticos.



**LASER WARNING: ¡Atención!** No mirar fijamente el haz ni observarlo directamente con instrumentos ópticos.



**LASER WARNING: Varning!** Rikta inte blicken in mot strålen och titta inte direkt på den genom optiska instrument.

## RELATED DOCUMENTATION

[General Safety Guidelines and Warnings | 39](#)

[Grounded Equipment Warning | 58](#)

[Installation Instructions Warning | 51](#)

[Radiation from Open Port Apertures Warning | 46](#)

# Installation and Maintenance Safety Information

## IN THIS CHAPTER

- Installation Instructions Warning | 51
- Chassis Lifting Guidelines for Junos Space Appliances | 52
- Ramp Warning | 53
- Rack-Mounting Warnings | 53
- Grounded Equipment Warning | 58
- Maintenance and Operational Safety Guidelines and Warnings | 59

## Installation Instructions Warning



**WARNING:** Read the installation instructions before you connect the device to a power source.

**Waarschuwing** Raadpleeg de installatie-aanwijzingen voordat u het systeem met de voeding verbindt.

**Varoitus** Lue asennusohjeet ennen järjestelmän yhdistämistä virtälähteeseen.

**Attention** Avant de brancher le système sur la source d'alimentation, consulter les directives d'installation.

**Warnung** Lesen Sie die Installationsanweisungen, bevor Sie das System an die Stromquelle anschließen.

**Avvertenza** Consultare le istruzioni di installazione prima di collegare il sistema all'alimentatore.

**Advarsel** Les installasjonsinstruksjonene før systemet kobles til strømkilden.

**Aviso** Leia as instruções de instalação antes de ligar o sistema à sua fonte de energia.

**¡Atención!** Ver las instrucciones de instalación antes de conectar el sistema a la red de alimentación.

**Varning!** Läs installationsanvisningarna innan du kopplar systemet till dess strömförsörjningsenhet.

## RELATED DOCUMENTATION

[General Safety Guidelines and Warnings | 39](#)

[Laser and LED Safety Guidelines and Warnings for Junos Space Appliances | 47](#)

[Grounded Equipment Warning | 58](#)

[Connecting AC Power to the Junos Space Appliance | 88](#)

[Connecting DC Power to the Junos Space Appliance | 90](#)

## Chassis Lifting Guidelines for Junos Space Appliances

The approximate weights of the Junos Space appliances are as follows:

- JA1500—27 lb (12.2 kg)
- JA2500—28.05 lb (12.72 kg)

Observe the following guidelines for lifting and moving a Junos Space appliance:

- Before installing a Junos Space appliance, read the guidelines in "[General Site Guidelines for Junos Space Appliances](#)" on page 17.
- Before lifting or moving the appliance, disconnect all external cables.
- As when lifting any heavy object, lift most of the weight with your legs rather than your back. Keep your knees bent and your back relatively straight and avoid twisting your body as you lift. Balance the load evenly and be sure that your footing is solid.

## RELATED DOCUMENTATION

[General Safety Guidelines and Warnings | 39](#)

[Installation Instructions Warning | 51](#)

[Mounting the JA2500 Junos Space Appliance | 83](#)

## Ramp Warning



**WARNING:** When installing the device, do not use a ramp inclined at more than 10 degrees.

**Waarschuwing** Gebruik een oprijplaat niet onder een hoek van meer dan 10 graden.

**Varoitus** Älä käytä sellaista kaltevaa pintaa, jonka kaltevuus ylittää 10 astetta.

**Attention** Ne pas utiliser une rampe dont l'inclinaison est supérieure à 10 degrés.

**Warnung** Keine Rampen mit einer Neigung von mehr als 10 Grad verwenden.

**Avvertenza** Non usare una rampa con pendenza superiore a 10 gradi.

**Advarsel** Bruk aldri en rampe som heller mer enn 10 grader.

**Aviso** Não utilize uma rampa com uma inclinação superior a 10 graus.

**¡Atención!** No usar una rampa inclinada más de 10 grados

**Warning!** Använd inte ramp med en lutning på mer än 10 grader.

### RELATED DOCUMENTATION

[General Safety Guidelines and Warnings | 39](#)

[Grounded Equipment Warning | 58](#)

[Installation Instructions Warning | 51](#)

## Rack-Mounting Warnings

Ensure that the rack or cabinet in which the device is installed is evenly and securely supported. Uneven mechanical loading could lead to a hazardous condition.



**WARNING:** To prevent bodily injury when mounting or servicing the device in a rack, take the following precautions to ensure that the system remains stable. The following directives help maintain your safety:

- The device must be installed in a rack that is secured to the building structure.

- The device should be mounted at the bottom of the rack if it is the only unit in the rack.
- When mounting the device on a partially filled rack, load the rack from the bottom to the top with the heaviest component at the bottom of the rack.
- If the rack is provided with stabilizing equipment, install the stabilizers before mounting or servicing the device in the rack.

**Waarschuwing** Om lichamelijk letsel te voorkomen wanneer u dit toestel in een rek monteert of het daar een servicebeurt geeft, moet u speciale voorzorgsmaatregelen nemen om ervoor te zorgen dat het toestel stabiel blijft. De onderstaande richtlijnen worden verstrekt om uw veiligheid te verzekeren:

- De Juniper Networks device moet in een stellage worden geïnstalleerd die aan een bouwsel is verankerd.
- Dit toestel dient onderaan in het rek gemonteerd te worden als het toestel het enige in het rek is.
- Wanneer u dit toestel in een gedeeltelijk gevuld rek monteert, dient u het rek van onderen naar boven te laden met het zwaarste onderdeel onderaan in het rek.
- Als het rek voorzien is van stabiliseringshulpmiddelen, dient u de stabilisatoren te monteren voordat u het toestel in het rek monteert of het daar een servicebeurt geeft.

**Varoitus** Kun laite asetetaan telineeseen tai huolletaan sen ollessa telineessä, on noudatettava erityisiä varotoimia järjestelmän vakavuuden säilyttämiseksi, jotta vältetään loukkaantumiset. Noudata seuraavia turvallisuusohjeita:

- Juniper Networks device on asennettava telineeseen, joka on kiinnitetty rakennukseen.
- Jos telineessä ei ole muita laitteita, aseta laite telineen alaosaan.
- Jos laite asetetaan osaksi täytettyyn telineeseen, aloita kuormittaminen sen alaosasta kaikkein raskaimmalla esineellä ja siirry sitten sen yläosaan.
- Jos telinettä varten on vakaimet, asenna ne ennen laitteen asettamista telineeseen tai sen huoltamista siinä.

**Attention** Pour éviter toute blessure corporelle pendant les opérations de montage ou de réparation de cette unité en casier, il convient de prendre des précautions spéciales

afin de maintenir la stabilité du système. Les directives ci-dessous sont destinées à assurer la protection du personnel:

- Le rack sur lequel est monté le Juniper Networks device doit être fixé à la structure du bâtiment.
- Si cette unité constitue la seule unité montée en casier, elle doit être placée dans le bas.
- Si cette unité est montée dans un casier partiellement rempli, charger le casier de bas en haut en plaçant l'élément le plus lourd dans le bas.
- Si le casier est équipé de dispositifs stabilisateurs, installer les stabilisateurs avant de monter ou de réparer l'unité en casier.

**Warnung** Zur Vermeidung von Körperverletzung beim Anbringen oder Warten dieser Einheit in einem Gestell müssen Sie besondere Vorkehrungen treffen, um sicherzustellen, daß das System stabil bleibt. Die folgenden Richtlinien sollen zur Gewährleistung Ihrer Sicherheit dienen:

- Der Juniper Networks device muß in einem Gestell installiert werden, das in der Gebäudestruktur verankert ist.
- Wenn diese Einheit die einzige im Gestell ist, sollte sie unten im Gestell angebracht werden.
- Bei Anbringung dieser Einheit in einem zum Teil gefüllten Gestell ist das Gestell von unten nach oben zu laden, wobei das schwerste Bauteil unten im Gestell anzubringen ist.
- Wird das Gestell mit Stabilisierungszubehör geliefert, sind zuerst die Stabilisatoren zu installieren, bevor Sie die Einheit im Gestell anbringen oder sie warten.

**Avvertenza** Per evitare infortuni fisici durante il montaggio o la manutenzione di questa unità in un supporto, occorre osservare speciali precauzioni per garantire che il sistema rimanga stabile. Le seguenti direttive vengono fornite per garantire la sicurezza personale:

- Il Juniper Networks device deve essere installato in un telaio, il quale deve essere fissato alla struttura dell'edificio.
- Questa unità deve venire montata sul fondo del supporto, se si tratta dell'unica unità da montare nel supporto.

- Quando questa unità viene montata in un supporto parzialmente pieno, caricare il supporto dal basso all'alto, con il componente più pesante sistemato sul fondo del supporto.
- Se il supporto è dotato di dispositivi stabilizzanti, installare tali dispositivi prima di montare o di procedere alla manutenzione dell'unità nel supporto.

**Advarsel** Unngå fysiske skader under montering eller reparasjonsarbeid på denne enheten når den befinner seg i et kabinett. Vær nøye med at systemet er stabilt. Følgende retningslinjer er gitt for å verne om sikkerheten:

- Juniper Networks device må installeres i et stativ som er forankret til bygningsstrukturen.
- Denne enheten bør monteres nederst i kabinettet hvis dette er den eneste enheten i kabinettet.
- Ved montering av denne enheten i et kabinett som er delvis fylt, skal kabinettet lastes fra bunnen og opp med den tyngste komponenten nederst i kabinettet.
- Hvis kabinettet er utstyrt med stabiliseringsutstyr, skal stabilisatorene installeres før montering eller utføring av reparasjonsarbeid på enheten i kabinettet.

**Aviso** Para se prevenir contra danos corporais ao montar ou reparar esta unidade numa estante, deverá tomar precauções especiais para se certificar de que o sistema possui um suporte estável. As seguintes directrizes ajudá-lo-ão a efectuar o seu trabalho com segurança:

- O Juniper Networks device deverá ser instalado numa prateleira fixa à estrutura do edifício.
- Esta unidade deverá ser montada na parte inferior da estante, caso seja esta a única unidade a ser montada.
- Ao montar esta unidade numa estante parcialmente ocupada, coloque os itens mais pesados na parte inferior da estante, arrumando-os de baixo para cima.
- Se a estante possuir um dispositivo de estabilização, instale-o antes de montar ou reparar a unidade.

**¡Atención!** Para evitar lesiones durante el montaje de este equipo sobre un bastidor, o posteriormente durante su mantenimiento, se debe poner mucho cuidado en que el sistema quede bien estable. Para garantizar su seguridad, proceda según las siguientes instrucciones:



- El Juniper Networks device debe instalarse en un bastidor fijado a la estructura del edificio.
- Colocar el equipo en la parte inferior del bastidor, cuando sea la única unidad en el mismo.
- Cuando este equipo se vaya a instalar en un bastidor parcialmente ocupado, comenzar la instalación desde la parte inferior hacia la superior colocando el equipo más pesado en la parte inferior.
- Si el bastidor dispone de dispositivos estabilizadores, instalar éstos antes de montar o proceder al mantenimiento del equipo instalado en el bastidor.

**Warning!** För att undvika kroppsskada när du installerar eller utför underhållsarbete på denna enhet på en ställning måste du vidta särskilda försiktighetsåtgärder för att försäkra dig om att systemet står stadigt. Följande riktlinjer ges för att trygga din säkerhet:

- Juniper Networks device måste installeras i en ställning som är förankrad i byggnadens struktur.
- Om denna enhet är den enda enheten på ställningen skall den installeras längst ned på ställningen.
- Om denna enhet installeras på en delvis fylld ställning skall ställningen fyllas nedifrån och upp, med de tyngsta enheterna längst ned på ställningen.
- Om ställningen är försedd med stabiliseringsdon skall dessa monteras fast innan enheten installeras eller underhålls på ställningen.

## RELATED DOCUMENTATION

[General Safety Guidelines and Warnings | 39](#)

[Grounded Equipment Warning | 58](#)

[Installation Instructions Warning | 51](#)

[Mounting the JA2500 Junos Space Appliance | 83](#)

## Grounded Equipment Warning



**WARNING:** The device is intended to be grounded. During normal use, ensure that you have connected earth ground to the chassis.

**Waarschuwing** Deze apparatuur hoort geaard te worden. Zorg dat de host-computer tijdens normaal gebruik met aarde is verbonden.

**Varoitus** Tämä laitteisto on tarkoitettu maadoitettavaksi. Varmista, että isäntälaitte on yhdistetty maahan normaalikäytön aikana.

**Attention** Cet équipement doit être relié à la terre. S'assurer que l'appareil hôte est relié à la terre lors de l'utilisation normale.

**Warnung** Dieses Gerät muß geerdet werden. Stellen Sie sicher, daß das Host-Gerät während des normalen Betriebs an Erde gelegt ist.

**Avvertenza** Questa apparecchiatura deve essere collegata a massa. Accertarsi che il dispositivo host sia collegato alla massa di terra durante il normale utilizzo.

**Advarsel** Dette utstyret skal jordes. Forviss deg om vertsterminalen er jordet ved normalt bruk.

**Aviso** Este equipamento deverá estar ligado à terra. Certifique-se que o host se encontra ligado à terra durante a sua utilização normal.

**¡Atención!** Este equipo debe conectarse a tierra. Asegurarse de que el equipo principal esté conectado a tierra durante el uso normal.

**Warning!** Denna utrustning är avsedd att jordas. Se till att värdenheten är jordad vid normal användning.

### RELATED DOCUMENTATION

[General Electrical Safety Guidelines and Warnings | 65](#)

[General Safety Guidelines and Warnings | 39](#)

## Maintenance and Operational Safety Guidelines and Warnings

### IN THIS SECTION

- Battery Handling Warning | 59
- Jewelry Removal Warning | 60
- Lightning Activity Warning | 61
- Operating Temperature Warning | 62
- Product Disposal Warning | 63

While performing the maintenance activities for devices, observe the following guidelines and warnings:

### Battery Handling Warning



**WARNING:** Replacing a battery incorrectly might result in an explosion. Replace a battery only with the same or equivalent type recommended by the manufacturer. Dispose of used batteries according to the manufacturer's instructions.

**Waarschuwing** Er is ontploffingsgevaar als de batterij verkeerd vervangen wordt. Vervang de batterij slechts met hetzelfde of een equivalent type dat door de fabrikant aanbevolen is. Gebruikte batterijen dienen overeenkomstig fabrieksvoorschriften weggeworpen te worden.

**Varoitus** Räjähdyksen vaara, jos akku on vaihdettu väärään akkuun. Käytä vaihtamiseen ainoastaan saman- tai vastaaventyypistä akkua, joka on valmistajan suosittelema. Hävitä käytetyt akut valmistajan ohjeiden mukaan.

**Attention** Danger d'explosion si la pile n'est pas remplacée correctement. Ne la remplacer que par une pile de type semblable ou équivalent, recommandée par le fabricant. Jeter les piles usagées conformément aux instructions du fabricant.

**Warnung** Bei Einsetzen einer falschen Batterie besteht Explosionsgefahr. Ersetzen Sie die Batterie nur durch den gleichen oder vom Hersteller empfohlenen Batterietyp. Entsorgen Sie die benutzten Batterien nach den Anweisungen des Herstellers.

**Advarsel** Det kan være fare for eksplosjon hvis batteriet skiftes på feil måte. Skift kun med samme eller tilsvarende type som er anbefalt av produsenten. Kasser brukte batterier i henhold til produsentens instruksjoner.

**Avvertenza** Pericolo di esplosione se la batteria non è installata correttamente. Sostituire solo con una di tipo uguale o equivalente, consigliata dal produttore. Eliminare le batterie usate secondo le istruzioni del produttore.

**Aviso** Existe perigo de explosão se a bateria for substituída incorrectamente. Substitua a bateria por uma bateria igual ou de um tipo equivalente recomendado pelo fabricante. Destrua as baterias usadas conforme as instruções do fabricante.

**¡Atención!** Existe peligro de explosión si la batería se reemplaza de manera incorrecta. Reemplazar la batería exclusivamente con el mismo tipo o el equivalente recomendado por el fabricante. Desechar las baterías gastadas según las instrucciones del fabricante.

**Varning!** Explosionsfara vid felaktigt batteribyte. Ersätt endast batteriet med samma batterityp som rekommenderas av tillverkaren eller motsvarande. Följ tillverkarens anvisningar vid kassering av använda batterier.

## Jewelry Removal Warning



**WARNING:** Before working on equipment that is connected to power lines, remove jewelry, including rings, necklaces, and watches. Metal objects heat up when connected to power and ground and can cause serious burns or can be welded to the terminals.

**Waarschuwing** Alvorens aan apparatuur te werken die met elektrische leidingen is verbonden, sieraden (inclusief ringen, kettingen en horloges) verwijderen. Metalen voorwerpen worden warm wanneer ze met stroom en aarde zijn verbonden, en kunnen ernstige brandwonden veroorzaken of het metalen voorwerp aan de aansluitklemmen lassen.

**Varoitus** Ennen kuin työskentelet voimavirtajohtoihin kytkettyjen laitteiden parissa, ota pois kaikki korut (sormukset, kaulakorut ja kellot mukaan lukien). Metalliesineet kuumenevat, kun ne ovat yhteydessä sähkövirran ja maan kanssa, ja ne voivat aiheuttaa vakavia palovammoja tai hitsata metalliesineet kiinni liitäntänapoihin.

**Attention** Avant d'accéder à cet équipement connecté aux lignes électriques, ôter tout bijou (anneaux, colliers et montres compris). Lorsqu'ils sont branchés à l'alimentation et reliés à la terre, les objets métalliques chauffent, ce qui peut provoquer des blessures graves ou souder l'objet métallique aux bornes.

**Warnung** Vor der Arbeit an Geräten, die an das Netz angeschlossen sind, jeglichen Schmuck (einschließlich Ringe, Ketten und Uhren) abnehmen. Metallgegenstände erhitzen sich, wenn sie an das Netz und die Erde angeschlossen werden, und können schwere Verbrennungen verursachen oder an die Anschlußklemmen angeschweißt werden.

**Avvertenza** Prima di intervenire su apparecchiature collegate alle linee di alimentazione, togliersi qualsiasi monile (inclusi anelli, collane, braccialetti ed orologi). Gli oggetti metallici si riscaldano quando sono collegati tra punti di alimentazione e massa: possono causare ustioni gravi oppure il metallo può saldarsi ai terminali.

**Advarsel** Fjern alle smykker (inkludert ringer, halskjeder og klokker) før du skal arbeide på utstyr som er koblet til kraftledninger. Metallgjenstander som er koblet til kraftledninger og jord blir svært varme og kan forårsake alvorlige brannskader eller smelte fast til polene.

**Aviso** Antes de trabalhar em equipamento que esteja ligado a linhas de corrente, retire todas as jóias que estiver a usar (incluindo anéis, fios e relógios). Os objectos metálicos aquecerão em contacto com a corrente e em contacto com a ligação à terra, podendo causar queimaduras graves ou ficarem soldados aos terminais.

**¡Atención!** Antes de operar sobre equipos conectados a líneas de alimentación, quitarse las joyas (incluidos anillos, collares y relojes). Los objetos de metal se calientan cuando se conectan a la alimentación y a tierra, lo que puede ocasionar quemaduras graves o que los objetos metálicos queden soldados a los bornes.

**Varning!** Tag av alla smycken (inklusive ringar, halsband och armbandsur) innan du arbetar på utrustning som är kopplad till kraftledningar. Metallobjekt hettas upp när de kopplas ihop med ström och jord och kan förorsaka allvarliga brännskador; metallobjekt kan också sammansvetsas med kontakterna.

## Lightning Activity Warning



**WARNING:** Do not work on the system or connect or disconnect cables during periods of lightning activity.

**Waarschuwing** Tijdens onweer dat gepaard gaat met bliksem, dient u niet aan het systeem te werken of kabels aan te sluiten of te ontkoppelen.

**Varoitus** Älä työskentele järjestelmän parissa äläkä yhdistä tai irrota kaapeleita ukkosilmalla.

**Attention** Ne pas travailler sur le système ni brancher ou débrancher les câbles pendant un orage.

**Warnung** Arbeiten Sie nicht am System und schließen Sie keine Kabel an bzw. trennen Sie keine ab, wenn es gewittert.

**Avvertenza** Non lavorare sul sistema o collegare oppure scollegare i cavi durante un temporale con fulmini.

**Advarsel** Utfør aldri arbeid på systemet, eller koble kabler til eller fra systemet når det tordner eller lyner.

**Aviso** Não trabalhe no sistema ou ligue e desligue cabos durante períodos de mau tempo (trovoada).

**¡Atención!** No operar el sistema ni conectar o desconectar cables durante el transcurso de descargas eléctricas en la atmósfera.

**Warning!** Vid áska skall du aldrig utföra arbete på systemet eller ansluta eller koppla loss kablar.

## Operating Temperature Warning



**WARNING:** To prevent the device from overheating, do not operate it in an area that exceeds the maximum recommended ambient temperature of 104° F (40° C) for network devices of Juniper Networks. To prevent airflow restriction, allow at least 6 in. (15.2 cm) of clearance around the ventilation openings.

**Waarschuwing** Om te voorkomen dat welke device van de Juniper Networks router dan ook oververhit raakt, dient u deze niet te bedienen op een plaats waar de maximale aanbevolen omgevingstemperatuur van 40° C wordt overschreden. Om te voorkomen dat de luchtstroom wordt beperkt, dient er minstens 15,2 cm speling rond de ventilatie-openingen te zijn.

**Varoitus** Ettei Juniper Networks device-sarjan reititin ylikuumentuisi, sitä ei saa käyttää tilassa, jonka lämpötila ylittää korkeimman suositellun ympäristölämpötilan 40° C. Ettei ilmanvaihto estyisi, tuuletusaukkojen ympärille on jätettävä ainakin 15,2 cm tilaa.

**Attention** Pour éviter toute surchauffe des routeurs de la gamme Juniper Networks device, ne l'utilisez pas dans une zone où la température ambiante est supérieure à 40° C. Pour permettre un flot d'air constant, dégagez un espace d'au moins 15,2 cm autour des ouvertures de ventilations.

**Warnung** Um einen device der device vor Überhitzung zu schützen, darf dieser nicht in einer Gegend betrieben werden, in der die Umgebungstemperatur das empfohlene Maximum von 40° C überschreitet. Um Lüftungsverschluß zu verhindern, achten Sie darauf, daß mindestens 15,2 cm lichter Raum um die Lüftungsöffnungen herum frei bleibt.

**Avvertenza** Per evitare il surriscaldamento dei device, non adoperateli in un locale che ecceda la temperatura ambientale massima di 40° C. Per evitare che la circolazione dell'aria sia impedita, lasciate uno spazio di almeno 15.2 cm di fronte alle aperture delle ventole.

**Advarsel** Unngå overoppheting av eventuelle rutere i Juniper Networks device Disse skal ikke brukes på steder der den anbefalte maksimale omgivelsestemperaturen overstiger 40° C (104° F). Sørg for at klaringen rundt lufteåpningene er minst 15,2 cm (6 tommer) for å forhindre nedsatt luftsirkulasjon.

**Aviso** Para evitar o sobreaquecimento do encaminhador Juniper Networks device, não utilize este equipamento numa área que exceda a temperatura máxima recomendada de 40° C. Para evitar a restrição à circulação de ar, deixe pelo menos um espaço de 15,2 cm à volta das aberturas de ventilação.

**¡Atención!** Para impedir que un encaminhador de la serie Juniper Networks device se recaliente, no lo haga funcionar en un área en la que se supere la temperatura ambiente máxima recomendada de 40° C. Para impedir la restricción de la entrada de aire, deje un espacio mínimo de 15,2 cm alrededor de las aperturas para ventilación.

**Varning!** Förhindra att en Juniper Networks device överhettas genom att inte använda den i ett område där den maximalt rekommenderade omgivningstemperaturen på 40° C överskrids. Förhindra att luftcirkulationen inskränks genom att se till att det finns fritt utrymme på minst 15,2 cm omkring ventilationsöppningarna.

## Product Disposal Warning



**WARNING:** Disposal of this device must be handled according to all national laws and regulations.

**Waarschuwing** Dit produkt dient volgens alle landelijke wetten en voorschriften te worden afgedankt.

**Varoitus** Tämän tuotteen lopullisesta hävittämisestä tulee huolehtia kaikkia valtakunnallisia lakeja ja säännöksiä noudattaen.

**Attention** La mise au rebut définitive de ce produit doit être effectuée conformément à toutes les lois et réglementations en vigueur.

**Warnung** Dieses Produkt muß den geltenden Gesetzen und Vorschriften entsprechend entsorgt werden.

**Avvertenza** L'eliminazione finale di questo prodotto deve essere eseguita osservando le normative italiane vigenti in materia

**Advarsel** Endelig disponering av dette produktet må skje i henhold til nasjonale lover og forskrifter.

**Aviso** A descartagem final deste produto deverá ser efectuada de acordo com os regulamentos e a legislação nacional.

**¡Atención!** El desecho final de este producto debe realizarse según todas las leyes y regulaciones nacionales

**Warning!** Slutlig kassering av denna produkt bör skötas i enlighet med landets alla lagar och föreskrifter.

## RELATED DOCUMENTATION

[AC Power Electrical Safety Guidelines | 68](#)

[DC Power Electrical Safety Guidelines | 71](#)

[General Electrical Safety Guidelines and Warnings | 65](#)

[General Safety Guidelines and Warnings | 39](#)

[Grounded Equipment Warning | 58](#)

[Installation Instructions Warning | 51](#)

[Laser and LED Safety Guidelines and Warnings for Junos Space Appliances | 47](#)



# Power and Electrical Safety Information

## IN THIS CHAPTER

- General Electrical Safety Guidelines and Warnings | 65
- Preventing Electrostatic Discharge Damage | 67
- AC Power Electrical Safety Guidelines | 68
- AC Power Disconnection Warning | 70
- DC Power Electrical Safety Guidelines | 71
- DC Power Disconnection Warning | 72
- DC Power Grounding Requirements and Warning | 74
- DC Power Wiring Sequence Warning | 75
- DC Power Wiring Terminations Warning | 76
- Multiple Power Supplies Disconnection Warning | 78
- TN Power Warning | 78
- Action to Take After an Electrical Accident | 79

## General Electrical Safety Guidelines and Warnings



**WARNING:** Certain ports on the device are designed for use as intrabuilding (within-the-building) interfaces only (Type 2 or Type 4 ports as described in *GR-1089-CORE*, Issue 4) and require isolation from the exposed outside plant (OSP) cabling. To protect against lightning surges and commercial power disturbances, the intrabuilding ports *must not* be metallically connected to interfaces that connect to the OSP or its wiring. The intrabuilding ports on the device are suitable for connection to intrabuilding or unexposed wiring or cabling only. The addition of primary protectors is not sufficient protection for connecting these interfaces metallically to OSP wiring.



**CAUTION:** Before removing or installing components of a device, attach an electrostatic discharge (ESD) grounding strap to an ESD point and place the other end of the strap around your bare wrist. Failure to use an ESD grounding strap could result in damage to the device.

- Install the device in compliance with the following local, national, and international electrical codes:
  - United States—National Fire Protection Association (NFPA 70), United States National Electrical Code.
  - Other countries—International Electromechanical Commission (IEC) 60364, Part 1 through Part 7.
  - Evaluated to the TN power system.
  - Canada—Canadian Electrical Code, Part 1, CSA C22.1.
- Locate the emergency power-off switch for the room in which you are working so that if an electrical accident occurs, you can quickly turn off the power.
- Make sure that grounding surfaces are cleaned and brought to a bright finish before grounding connections are made.
- Do not work alone if potentially hazardous conditions exist anywhere in your workspace.
- Never assume that power is disconnected from a circuit. Always check the circuit before starting to work.
- Carefully look for possible hazards in your work area, such as moist floors, ungrounded power extension cords, and missing safety grounds.
- Operate the device within marked electrical ratings and product usage instructions.
- To ensure that the device and peripheral equipment function safely and correctly, use the cables and connectors specified for the attached peripheral equipment, and make certain they are in good condition.

You can remove and replace many device components without powering off or disconnecting power to the device, as explained in the hardware documentation for this device. Never install an equipment that appears to be damaged.

## RELATED DOCUMENTATION

[AC Power Electrical Safety Guidelines | 68](#)

[Action to Take After an Electrical Accident | 79](#)

[DC Power Electrical Safety Guidelines | 71](#)

[General Safety Guidelines and Warnings | 39](#)

[Multiple Power Supplies Disconnection Warning | 78](#)

[TN Power Warning | 78](#)

## Preventing Electrostatic Discharge Damage

Device components that are shipped in antistatic bags are sensitive to damage from static electricity. Some components can be impaired by voltages as low as 30 V. You can easily generate potentially damaging static voltages whenever you handle plastic or foam packing material or if you move components across plastic or carpets. Observe the following guidelines to minimize the potential for electrostatic discharge (ESD) damage, which can cause intermittent or complete component failures:

- Always use an ESD grounding strap when you are handling components that are subject to ESD damage, and make sure that it is in direct contact with your skin.

If a grounding strap is not available, hold the component in its antistatic bag (see [Figure 6 on page 68](#)) in one hand and touch the exposed, bare metal of the device with the other hand immediately before inserting the component into the device.



**WARNING:** For safety, periodically check the resistance value of the ESD grounding strap. The measurement must be in the range 1 through 10 Mohms.

- When handling any component that is subject to ESD damage and that is removed from the device, make sure the equipment end of your ESD grounding strap is attached to the ESD point on the chassis.

If no grounding strap is available, touch the exposed, bare metal of the device to ground yourself before handling the component.

- Avoid contact between the component that is subject to ESD damage and your clothing. ESD voltages emitted from clothing can damage components.
- When removing or installing a component that is subject to ESD damage, always place it component-side up on an antistatic surface, in an antistatic card rack, or in an antistatic bag (see [Figure 6 on page 68](#)). If you are returning a component, place it in an antistatic bag before packing it.

Figure 6: Place a Component into an Antistatic Bag

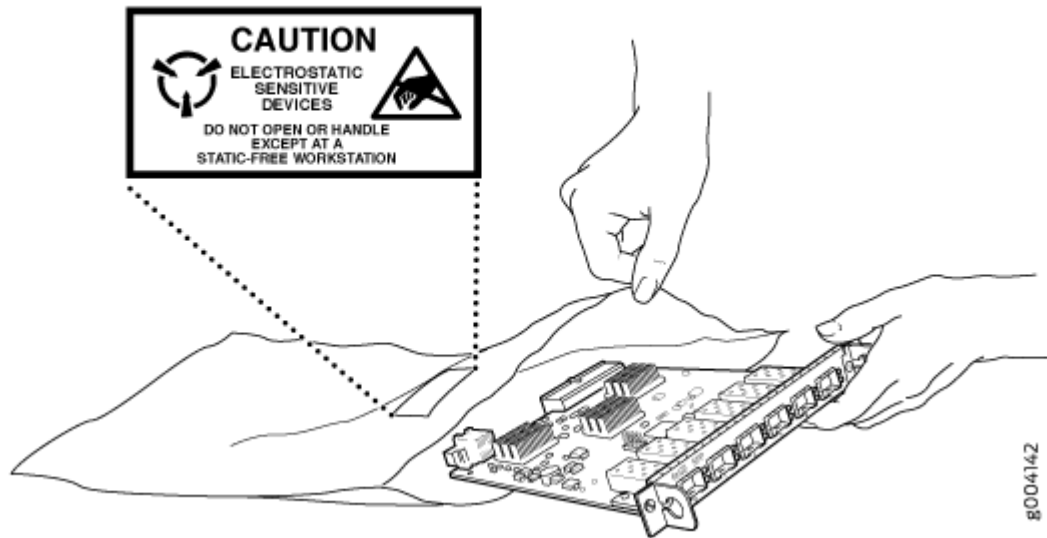

**CAUTION:** ANSI/TIA/EIA-568 cables such as Category 5e and Category 6 can get electrostatically charged. To dissipate this charge, always ground the cables to a suitable and safe earth ground before connecting them to the system.

## RELATED DOCUMENTATION

[General Electrical Safety Guidelines and Warnings | 65](#)

[General Safety Guidelines and Warnings | 39](#)

## AC Power Electrical Safety Guidelines



**CAUTION:** For devices with AC power supplies, an external surge protective device (SPD) must be used at the AC power source.

The following electrical safety guidelines apply to AC-powered devices:

- Note the following warnings printed on the device:

**“CAUTION: THIS UNIT HAS MORE THAN ONE POWER SUPPLY CORD. DISCONNECT ALL POWER SUPPLY CORDS BEFORE SERVICING TO AVOID ELECTRIC SHOCK.”**

**“ATTENTION: CET APPAREIL COMPORTE PLUS D'UN CORDON D'ALIMENTATION. AFIN DE PRÉVENIR LES CHOCS ÉLECTRIQUES, DÉBRANCHER TOUT CORDON D'ALIMENTATION AVANT DE FAIRE LE DÉPANNAGE.”**

- AC-powered devices are shipped with a three-wire electrical cord with a grounding-type plug that fits only a grounding-type power outlet. Do not circumvent this safety feature. Equipment grounding must comply with local and national electrical codes.
- You must provide an external certified circuit breaker rated minimum 20 A in the building installation.
- The power cord serves as the main disconnecting device for the AC-powered device. The socket outlet must be near the AC-powered device and be easily accessible.
- For devices that have more than one power supply connection, you must ensure that all power connections are fully disconnected so that power to the device is completely removed to avoid electric shock. To disconnect power, unplug all power cords (one for each power supply module).

#### Power Cable Warning (Japanese)

**WARNING:** The attached power cable is only for this product. Do not use the cable for another product.

**注意**

**附属の電源コードセットはこの製品専用です。  
他の電気機器には使用しないでください。**

04777283

## RELATED DOCUMENTATION

[General Electrical Safety Guidelines and Warnings | 65](#)

[General Safety Guidelines and Warnings | 39](#)

[Multiple Power Supplies Disconnection Warning | 78](#)

[Connecting AC Power to the Junos Space Appliance | 88](#)

## AC Power Disconnection Warning



**WARNING:** Before working on the device or near power supplies, unplug all the power cords from the appliance.

**Waarschuwing** Voordat u aan een frame of in de nabijheid van voedingen werkt, dient u bij wisselstroom toestellen de stekker van het netsnoer uit het stopcontact te halen.

**Varoitus** Kytke irti vaihtovirtalaitteiden virtajohto, ennen kuin teet mitään asennuspohjalle tai työskentelet virtalähteiden läheisyydessä.

**Attention** Avant de travailler sur un châssis ou à proximité d'une alimentation électrique, débrancher le cordon d'alimentation des unités en courant alternatif.

**Warnung** Bevor Sie an einem Chassis oder in der Nähe von Netzgeräten arbeiten, ziehen Sie bei Wechselstromeinheiten das Netzkabel ab bzw.

**Avvertenza** Prima di lavorare su un telaio o intorno ad alimentatori, scollegare il cavo di alimentazione sulle unità CA.

**Advarsel** Før det utføres arbeid på kabinettet eller det arbeides i nærheten av strømforsyningsenheter, skal strømledningen trekkes ut på vekselstrømsenheter.

**Aviso** Antes de trabalhar num chassis, ou antes de trabalhar perto de unidades de fornecimento de energia, desligue o cabo de alimentação nas unidades de corrente alternada.

**¡Atención!** Antes de manipular el chasis de un equipo o trabajar cerca de una fuente de alimentación, desenchufar el cable de alimentación en los equipos de corriente alterna (CA).

**Warning!** Innan du arbetar med ett chassi eller nära strömförsörjningsenheter skall du för växelströmsenheter dra ur nätsladden.

### RELATED DOCUMENTATION

[AC Power Electrical Safety Guidelines | 68](#)

[General Electrical Safety Guidelines and Warnings | 65](#)

[General Safety Guidelines and Warnings | 39](#)

## DC Power Electrical Safety Guidelines

- A DC-powered device is equipped with a DC terminal block that is rated for the power requirements of a maximally configured device.

**NOTE:** To supply sufficient power, terminate the DC input wiring on a facility DC source that is capable of supplying a maximum inrush current of 30 A at power-up

Incorporate an easily accessible disconnect device into the facility wiring. Be sure to connect the ground wire or conduit to a solid office earth ground. A closed loop ring is recommended for terminating the ground conductor at the ground stud.

- Run two wires from the circuit breaker box to a source of -48 VDC. (The range supported by the DC power supply is -45 VDC to -60 VDC.)
- A DC-powered device that is equipped with a DC terminal block is intended only for installation in a restricted access location. In the United States, a restricted access area is one in accordance with Articles 110-16, 110-17, and 110-18 of the National Electrical Code ANSI/NFPA 70.

**NOTE:** Primary overcurrent protection is provided by the building circuit breaker. This breaker must protect against excess currents, short circuits, and earth grounding faults in accordance with NEC ANSI/NFPA 70.

- Ensure that the polarity of the DC input wiring is correct. Under certain conditions, connections with reversed polarity might trip the primary circuit breaker or damage the equipment.
- For personal safety, connect the green and yellow wire to safety (earth) ground at both the device and the supply side of the DC wiring.
- The marked input voltage of -45 VDC for a DC-powered device is the nominal voltage associated with the battery circuit, and any higher voltages are only to be associated with float voltages for the charging function.
- Because the device is a positive ground system, you must connect the positive lead to the terminal labeled RTN, the negative lead to the terminal labeled -45 VDC, and the earth ground to the device grounding points.

### RELATED DOCUMENTATION

[DC Power Disconnection Warning | 72](#)

DC Power Grounding Requirements and Warning   74
DC Power Wiring Sequence Warning   75
DC Power Wiring Terminations Warning   76
General Electrical Safety Guidelines and Warnings   65
General Safety Guidelines and Warnings   39
Multiple Power Supplies Disconnection Warning   78
Connecting DC Power to the Junos Space Appliance   90

## DC Power Disconnection Warning



**WARNING:** Before performing any of the DC power procedures, ensure that power is removed from the DC circuit. To ensure that all power is off, locate the circuit breaker on the panel board that services the DC circuit, switch the circuit breaker to the OFF position, and tape the device handle of the circuit breaker in the OFF position.

**Waarschuwing** Voordat u een van de onderstaande procedures uitvoert, dient u te controleren of de stroom naar het gelijkstroom circuit uitgeschakeld is. Om u ervan te verzekeren dat alle stroom UIT is geschakeld, kiest u op het schakelbord de stroomverbreker die het gelijkstroom circuit bedient, draait de stroomverbreker naar de UIT positie en plakt de schakelaarhendel van de stroomverbreker met plakband in de UIT positie vast.

**Varoitus** Varmista, että tasavirtapiirissä ei ole virtaa ennen seuraavien toimenpiteiden suorittamista. Varmistaaksesi, että virta on KATKAISTU täysin, paikanna tasavirrasta huolehtivassa kojetaulussa sijaitseva suojakytkin, käännä suojakytkin KATKAISTU-asentoon ja teippaa suojakytkimen varsi niin, että se pysyy KATKAISTU-asennossa.

**Attention** Avant de pratiquer l'une quelconque des procédures ci-dessous, vérifier que le circuit en courant continu n'est plus sous tension. Pour en être sûr, localiser le disjoncteur situé sur le panneau de service du circuit en courant continu, placer le disjoncteur en position fermée (OFF) et, à l'aide d'un ruban adhésif, bloquer la poignée du disjoncteur en position OFF.

**Warnung** Vor Ausführung der folgenden Vorgänge ist sicherzustellen, daß die Gleichstromschaltung keinen Strom erhält. Um sicherzustellen, daß sämtlicher Strom abgestellt ist, machen Sie auf der Schalttafel den Unterbrecher für die Gleichstromschaltung ausfindig, stellen Sie den Unterbrecher auf AUS, und kleben Sie den Schaltergriff des Unterbrechers mit Klebeband in der AUS-Stellung fest.



**Avvertenza** Prima di svolgere una qualsiasi delle procedure seguenti, verificare che il circuito CC non sia alimentato. Per verificare che tutta l'alimentazione sia scollegata (OFF), individuare l'interruttore automatico sul quadro strumenti che alimenta il circuito CC, mettere l'interruttore in posizione OFF e fissarlo con nastro adesivo in tale posizione.

**Advarsel** Før noen av disse prosedyrene utføres, kontroller at strømmen er frakoblet likestrømkretsen. Sørg for at all strøm er slått AV. Dette gjøres ved å lokalisere strømbryteren på brytertavlen som betjener likestrømkretsen, slå strømbryteren AV og teipe bryterhåndtaket på strømbryteren i AV-stilling.

**Aviso** Antes de executar um dos seguintes procedimentos, certifique-se que desligou a fonte de alimentação de energia do circuito de corrente contínua. Para se assegurar que toda a corrente foi DESLIGADA, localize o disjuntor no painel que serve o circuito de corrente contínua e coloque-o na posição OFF (Desligado), segurando nessa posição a manivela do interruptor do disjuntor com fita isoladora.

**¡Atención!** Antes de proceder con los siguientes pasos, comprobar que la alimentación del circuito de corriente continua (CC) esté cortada (OFF). Para asegurarse de que toda la alimentación esté cortada (OFF), localizar el interruptor automático en el panel que alimenta al circuito de corriente continua, cambiar el interruptor automático a la posición de Apagado (OFF), y sujetar con cinta la palanca del interruptor automático en posición de Apagado (OFF).

**Warning!** Innan du utför någon av följande procedurer måste du kontrollera att strömförsörjningen till likstrømskretsen är bruten. Kontrollera att all strömförsörjning är BRUTEN genom att slå AV det överspänningsskydd som skyddar likstrømskretsen och tejpa fast överspänningsskyddets omkopplare i FRÅN-läget.

## RELATED DOCUMENTATION

[DC Power Electrical Safety Guidelines | 71](#)

[DC Power Grounding Requirements and Warning | 74](#)

[DC Power Wiring Sequence Warning | 75](#)

[DC Power Wiring Terminations Warning | 76](#)

[General Electrical Safety Guidelines and Warnings | 65](#)

[General Safety Guidelines and Warnings | 39](#)

## DC Power Grounding Requirements and Warning

An insulated grounding conductor that is identical in size to the grounded and ungrounded branch circuit supply conductors but is identifiable by green and yellow stripes is installed as part of the branch circuit that supplies the device. The grounding conductor is a separately derived system at the supply transformer or motor generator set.



**WARNING:** When you install the device, the ground connection must always be made first and disconnected last.

**Waarschuwing** Bij de installatie van het toestel moet de aardverbinding altijd het eerste worden gemaakt en het laatste worden losgemaakt.

**Varoitus** Laitetta asennettaessa on maahan yhdistäminen aina tehtävä ensiksi ja maadoituksen irti kytkeminen viimeiseksi.

**Attention** Lors de l'installation de l'appareil, la mise à la terre doit toujours être connectée en premier et déconnectée en dernier.

**Warnung** Der Erdanschluß muß bei der Installation der Einheit immer zuerst hergestellt und zuletzt abgetrennt werden.

**Avvertenza** In fase di installazione dell'unità, eseguire sempre per primo il collegamento a massa e disconnetterlo per ultimo.

**Advarsel** Når enheten installeres, må jordledningen alltid tilkobles først og frakobles sist.

**Aviso** Ao instalar a unidade, a ligação à terra deverá ser sempre a primeira a ser ligada, e a última a ser desligada.

**¡Atención!** Al instalar el equipo, conectar la tierra la primera y desconectarla la última.

**Warning!** Vid installation av enheten måste jordledningen alltid anslutas först och kopplas bort sist.

### RELATED DOCUMENTATION

[DC Power Electrical Safety Guidelines | 71](#)

[DC Power Disconnection Warning | 72](#)

[DC Power Wiring Sequence Warning | 75](#)

[DC Power Wiring Terminations Warning | 76](#)

[General Electrical Safety Guidelines and Warnings | 65](#)

[General Safety Guidelines and Warnings | 39](#)

## DC Power Wiring Sequence Warning



**WARNING:** Wire the DC power supply using the appropriate lugs. When connecting power, the proper wiring sequence is ground to ground, +RTN to +RTN, then -45 V to -60 V. When disconnecting power, the proper wiring sequence is -45 V to -60 V, +RTN to +RTN, then ground to ground. Note that the ground wire must always be connected first and disconnected last.

**Waarschuwing** De juiste bedradingsvolgorde verbonden is aarde naar aarde, +RTN naar +RTN, en -45 V naar -60 V. De juiste bedradingsvolgorde losgemaakt is en -45 naar -60 V, +RTN naar +RTN, aarde naar aarde.

**Varoitus** Oikea yhdistettävä kytkentäjärjestys on maajohto maajohtoon, +RTN varten +RTN, -45 V varten -60 V. Oikea irrotettava kytkentäjärjestys on -45 V varten -60 V, +RTN varten +RTN, maajohto maajohtoon.

**Attention** Câblez l'alimentation d'alimentation CC En utilisant les crochets appropriés à l'extrémité de câblage. En reliant la puissance, l'ordre approprié de câblage est rectifié pour rectifier, +RTN à +RTN, puis -45 V à -60 V. En débranchant la puissance, l'ordre approprié de câblage est -45 V à -60 V, +RTN à +RTN, a alors rectifié pour rectifier. Notez que le fil de masse devrait toujours être relié d'abord et débranché pour la dernière fois. Notez que le fil de masse devrait toujours être relié d'abord et débranché pour la dernière fois.

**Warnung** Die Stromzufuhr ist nur mit geeigneten Ringösen an das DC Netzteil anzuschliessen. Die richtige Anschlusssequenz ist: Erdanschluss zu Erdanschluss, +RTN zu +RTN und dann -45 V zu -60V. Die richtige Sequenz zum Abtrennen der Stromversorgung ist -45 V zu -60 V, +RTN zu +RTN und dann Erdanschluss zu Erdanschluss. Es ist zu beachten dass der Erdanschluss immer zuerst angeschlossen und als letztes abgetrennt wird.

**Avvertenza** Mostra la morsettiera dell'alimentatore CC. Cablare l'alimentatore CC usando i connettori adatti all'estremità del cablaggio, come illustrato. La corretta sequenza di cablaggio è da massa a massa, da positivo a positivo (da linea ad L) e da negativo a negativo (da neutro a N). Tenere presente che il filo di massa deve sempre venire collegato per primo e scollegato per ultimo.

**Advarsel** Riktig tilkoples tilkoplingssekvens er jord til jord, +RTN til +RTN, -45 V til -60 V. Riktig frakoples tilkoplingssekvens er -45 V til -60 V, +RTN til +RTN, jord til jord.

**Aviso** Ate con alambre la fuente de potencia cc Usando los terminales apropiados en el extremo del cableado. Al conectar potencia, la secuencia apropiada del cableado se muele para moler, +RTN a +RTN, entonces -45 V a -60 V. Al desconectar potencia, la

secuencia apropiada del cableado es -45 V a -60 V, +RTN a +RTN, entonces molíó para moler. Observe que el alambre de tierra se debe conectar siempre primero y desconectar por último. Observe que el alambre de tierra se debe conectar siempre primero y desconectar por último.

**¡Atención!** Wire a fonte de alimentação de DC Usando os talões apropriados na extremidade da fiação. Ao conectar a potência, a seqüência apropriada da fiação é moída para moer, +RTN a +RTN, então -45 V a -60 V. Ao desconectar a potência, a seqüência apropriada da fiação é -45 V a -60 V, +RTN a +RTN, moeu então para moer. Anote que o fio à terra deve sempre ser conectado primeiramente e desconectado por último. Anote que o fio à terra deve sempre ser conectado primeiramente e desconectado por último.

**Warning!** Korrekt kopplingssekvens ar jord till jord, +RTN till +RTN, -45 V till -60 V. Korrekt kopplas kopplingssekvens ar -45 V till -60 V, +RTN till +RTN, jord till jord.

## RELATED DOCUMENTATION

[DC Power Electrical Safety Guidelines | 71](#)

[DC Power Disconnection Warning | 72](#)

[DC Power Grounding Requirements and Warning | 74](#)

[DC Power Wiring Terminations Warning | 76](#)

[General Electrical Safety Guidelines and Warnings | 65](#)

[General Safety Guidelines and Warnings | 39](#)

## DC Power Wiring Terminations Warning



**WARNING:** When stranded wiring is required, use approved wiring terminations, such as closed-loop or spade-type with upturned lugs. These terminations must be the appropriate size for the wires and must clamp both the insulation and conductor.

**Waarschuwing** Wanneer geslagen bedrading vereist is, dient u bedrading te gebruiken die voorzien is van goedgekeurde aansluitingspunten, zoals het gesloten-lus type of het grijperschop type waarbij de aansluitpunten omhoog wijzen. Deze aansluitpunten dienen de juiste maat voor de draden te hebben en dienen zowel de isolatie als de geleider vast te klemmen.

**Varoitus** Jos säikeellinen johdin on tarpeen, käytä hyväksyttyä johdinliitääntää, esimerkiksi suljettua silmukkaa tai kourumaista liitääntää, jossa on ylöspäin käännetyt kiinnityskorvat. Tällaisten liitääntöjen tulee olla kooltaan johtimiin sopivia ja niiden tulee puristaa yhteen sekä eristeen että johdinosan.

**Attention** Quand des fils torsadés sont nécessaires, utiliser des douilles terminales homologuées telles que celles à circuit fermé ou du type à plage ouverte avec cosses rebroussées. Ces douilles terminales doivent être de la taille qui convient aux fils et doivent être refermées sur la gaine isolante et sur le conducteur.

**Warnung** Wenn Litzenverdrahtung erforderlich ist, sind zugelassene Verdrahtungsabschlüsse, z.B. für einen geschlossenen Regelkreis oder gabelförmig, mit nach oben gerichteten Kabelschuhen zu verwenden. Diese Abschlüsse sollten die angemessene Größe für die Drähte haben und sowohl die Isolierung als auch den Leiter festklemmen.

**Avvertenza** Quando occorre usare trecce, usare connettori omologati, come quelli a occhio o a forcilla con linguette rivolte verso l'alto. I connettori devono avere la misura adatta per il cablaggio e devono serrare sia l'isolante che il conduttore.

**Advarsel** Hvis det er nødvendig med flertrådede ledninger, brukes godkjente ledningsavslutninger, som for eksempel lukket sløyfe eller spadetype med oppoverbøyde kabelsko. Disse avslutningene skal ha riktig størrelse i forhold til ledningene, og skal klemme sammen både isolasjonen og ledaren.

**Aviso** Quando forem requeridas montagens de instalação eléctrica de cabo torcido, use terminações de cabo aprovadas, tais como, terminações de cabo em circuito fechado e planas com terminais de orelha voltados para cima. Estas terminações de cabo deverão ser do tamanho apropriado para os respectivos cabos, e deverão prender simultaneamente o isolamento e o fio condutor.

**¡Atención!** Cuando se necesite hilo trenzado, utilizar terminales para cables homologados, tales como las de tipo "bucle cerrado" o "espada", con las lengüetas de conexión vueltas hacia arriba. Estos terminales deberán ser del tamaño apropiado para los cables que se utilicen, y tendrán que sujetar tanto el aislante como el conductor.

**Varning!** När flertrådiga ledningar krävs måste godkända ledningskontakter användas, t.ex. kabelsko av sluten eller öppen typ med uppåtvänd tapp. Storleken på dessa kontakter måste vara avpassad till ledningarna och måste kunna hålla både isoleringen och ledaren fastklämda.

## RELATED DOCUMENTATION

[DC Power Electrical Safety Guidelines | 71](#)

[DC Power Disconnection Warning | 72](#)

[DC Power Grounding Requirements and Warning | 74](#)

[DC Power Wiring Sequence Warning | 75](#)

[General Electrical Safety Guidelines and Warnings | 65](#)

[General Safety Guidelines and Warnings | 39](#)

## Multiple Power Supplies Disconnection Warning



**WARNING:** For a device that has more than one power supply connection, you must ensure that all power connections are fully disconnected so that power to the device is completely removed.

## RELATED DOCUMENTATION

[AC Power Electrical Safety Guidelines | 68](#)

[DC Power Electrical Safety Guidelines | 71](#)

[General Electrical Safety Guidelines and Warnings | 65](#)

[General Safety Guidelines and Warnings | 39](#)

## TN Power Warning



**WARNING:** The device is designed to work with a TN power system.

**Waarschuwing** Het apparaat is ontworpen om te functioneren met TN energiesystemen.

**Varoitus** Koje on suunniteltu toimimaan TN-sähkövoimajärjestelmien yhteydessä.

**Attention** Ce dispositif a été conçu pour fonctionner avec des systèmes d'alimentation TN.

**Warnung** Das Gerät ist für die Verwendung mit TN-Stromsystemen ausgelegt.

**Avvertenza** Il dispositivo è stato progettato per l'uso con sistemi di alimentazione TN.

**Advarsel** Utstyret er utfomet til bruk med TN-strømsystemer.

**Aviso** O dispositivo foi criado para operar com sistemas de corrente TN.

**¡Atención!** El equipo está diseñado para trabajar con sistemas de alimentación tipo TN.

**Varning!** Enheten är konstruerad för användning tillsammans med elkraftssystem av TN-typ.

## RELATED DOCUMENTATION

[General Electrical Safety Guidelines and Warnings | 65](#)

[General Safety Guidelines and Warnings | 39](#)

[Grounded Equipment Warning | 58](#)

[Multiple Power Supplies Disconnection Warning | 78](#)

## Action to Take After an Electrical Accident

If an electrical accident results in an injury, take the following actions in this order:

1. Use caution. Be aware of potentially hazardous conditions that could cause further injury.
2. Disconnect power from the device.
3. If possible, send another person to get medical aid. Otherwise, assess the condition of the victim, then call for help.

## RELATED DOCUMENTATION

[AC Power Electrical Safety Guidelines | 68](#)

[DC Power Electrical Safety Guidelines | 71](#)

[General Electrical Safety Guidelines and Warnings | 65](#)

[General Safety Guidelines and Warnings | 39](#)

# 4

PART

## Installation and Configuration

---

Installing the Appliance | 81

Connecting the Appliance | 88

Performing Initial Configuration | 96

Changing Network and System Settings | 151

---



# Installing the Appliance

## IN THIS CHAPTER

- Tools and Parts Required to Install the Junos Space Appliance | 81
- Unpacking the JA2500 Junos Space Appliance | 82
- Mounting the JA2500 Junos Space Appliance | 83
- Front-and-Rear Mounting the JA2500 Junos Space Appliance Flush to a Rack | 84
- Front-and-Rear Mounting the JA2500 Junos Space Appliance Recessed in a Rack | 85
- Midmounting the Junos Space Appliance in a Two-Post Rack | 86

## Tools and Parts Required to Install the Junos Space Appliance

Table 15 on page 81 lists the tools and equipment required for installing and maintaining the Junos Space Appliance.

**Table 15: Required Tools and Parts for Installing the Junos Space Appliance**

Task	Tools and Parts
Installing the appliance	<ul style="list-style-type: none"> <li>● Phillips (+) screwdriver, number 2</li> <li>● Phillips (+) screwdriver, number 3</li> <li>● (Optional) Tie wrap</li> </ul>
Connecting the appliance	<p>(Optional) ESD grounding wrist strap</p> <p>Phillips (+) screwdriver, number 1 for connecting the power supply wires and the grounding wire for the DC power supply module.</p>

**Table 15: Required Tools and Parts for Installing the Junos Space Appliance (Continued)**

Task	Tools and Parts
Packing the appliance	<ul style="list-style-type: none"> <li>• Electrostatic bag or antistatic mat, for each component</li> <li>• (Optional) ESD grounding wrist strap</li> </ul>

**RELATED DOCUMENTATION**

[Junos Space Appliance Rack Requirements](#) | 21

[Mounting the JA2500 Junos Space Appliance](#) | 83

**Unpacking the JA2500 Junos Space Appliance**

The JA2500 Junos Space Appliance is shipped in a cardboard carton along with the items listed in [Table 16 on page 83](#).



**CAUTION:** The JA2500 appliance is maximally protected inside the shipping carton. Do not unpack it until you are ready to begin installation.



**WARNING:** The shipping dimensions of a JA2500 appliance are 17.81 in x 17.31 in x 3.5 in (45.2 cm x 44 cm x 8.89 cm), and the appliance shipping weight is 28.05 lb (12.72 kg).. Use the correct lifting technique when you move the appliance. (Refer to "[Chassis Lifting Guidelines for Junos Space Appliances](#)" on page 52 for more details.)

To unpack the appliance, do the following:

1. Move the shipping carton to a staging area as close to the installation site as possible, ensuring that you have enough room to remove the system components.
2. Position the carton so that the arrows are pointing up.
3. Open the top flaps on the shipping carton.
4. Pull out the packing material holding the appliance in place.
5. Read the "[General Safety Guidelines and Warnings](#)" on page 39 carefully.
6. Remove the appliance from the shipping carton.

7. Verify the appliance chassis components received against the packing list. [Table 16 on page 83](#) lists the items provided with the appliance.
8. Save the shipping carton and packing materials in case you need to move or ship the appliance later.

**Table 16: Items in the JA2500 Appliance Shipping Carton**

Component	Quantity
Junos Space JA2500 appliance chassis	1
Power cable	1
Mounting kits	2
RJ-45 to DB-9F cable with adapter, 7 ft console cable	1
7-ft, blue, Category 5e cable	2
Safety Information Reference for Hardware Platforms	1

## RELATED DOCUMENTATION

[Junos Space Appliance Rack Requirements | 21](#)

[Mounting the JA2500 Junos Space Appliance | 83](#)

[Tools and Parts Required to Install the Junos Space Appliance | 81](#)

## Mounting the JA2500 Junos Space Appliance

You can mount the JA2500 Junos Space Appliance in one of the following ways:

- Front and rear flush to a rack—Refer to the "[Front-and-Rear Mounting the JA2500 Junos Space Appliance Flush to a Rack](#)" on page 84 topic for details.
- Front and rear recessed in a rack—Refer to the "[Front-and-Rear Mounting the JA2500 Junos Space Appliance Recessed in a Rack](#)" on page 85 topic for details.

- Midmounted in a two-post rack—Refer to the "[Midmounting the Junos Space Appliance in a Two-Post Rack](#)" on [page 86](#) topic for details.

## RELATED DOCUMENTATION

[Junos Space Appliance Rack Requirements](#) | 21

[Tools and Parts Required to Install the Junos Space Appliance](#) | 81

## Front-and-Rear Mounting the JA2500 Junos Space Appliance Flush to a Rack

This mounting option is used for larger chassis that require additional support when mounted on the rack-mount system.

To mount the JA2500 appliance front and rear flush to a rack, do the following:

1. Insert four rack-mount screws on each side of the appliance to secure the front of the chassis to the equipment rack.
2. Slide the rear-mount rail brackets into the backs of the front rails on either side of the chassis and align with your rear equipment rack posts, as shown in [Figure 7 on page 85](#).
3. Secure the rear-mount rail brackets to your equipment rack with two rack-mount screws each.
4. Insert locking screws on the sides of the rear-mount brackets to secure the front and rear mounting brackets in place.

Figure 7: Front-and-Rear Mounting Flush to a Rack

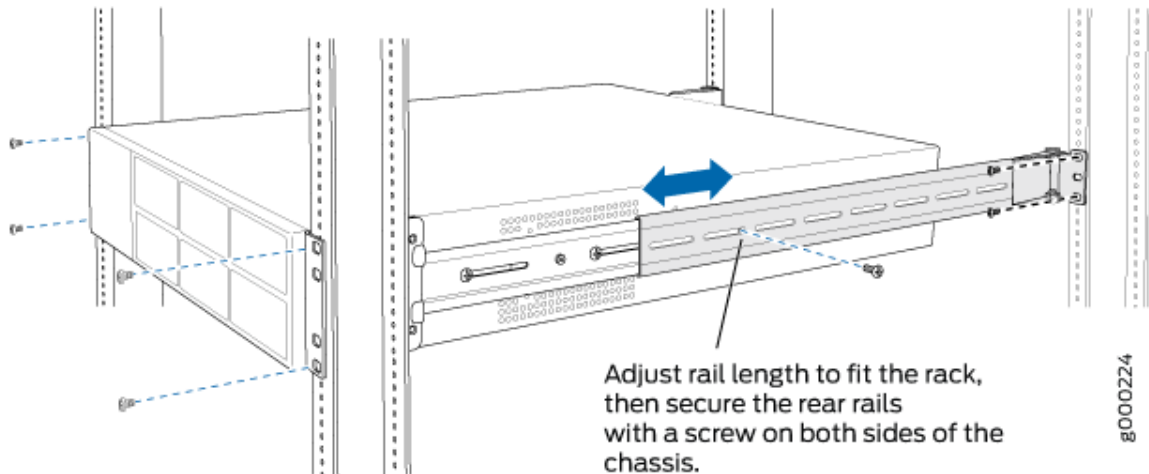

5. Verify that the mounting screws on one side of the rack are aligned with the mounting screws on the opposite side and that the appliance is level.

#### RELATED DOCUMENTATION

[Front-and-Rear Mounting the JA2500 Junos Space Appliance Recessed in a Rack | 85](#)

[Junos Space Appliance Rack Requirements | 21](#)

[Midmounting the Junos Space Appliance in a Two-Post Rack | 86](#)

[Tools and Parts Required to Install the Junos Space Appliance | 81](#)

## Front-and-Rear Mounting the JA2500 Junos Space Appliance Recessed in a Rack

This mounting option provides additional front clearance in the equipment rack. It is used for a larger chassis that requires additional support when mounted on the rack-mount system.

To mount the JA2500 appliance front and rear recessed in a rack, do the following:

1. Remove the rear screws on each side of the appliance's front rails and the two small screws toward the front of the chassis.
2. Loosen the side-rail screws of the chassis and slide the front rails of the system backward, as far as they will move.
3. Tighten the side-rail screws.
4. Insert the two small screws in the recessed holes on the front rails and tighten.

- Slide the rear-mount rail brackets into the backs of the front rails on either side of the chassis and align with your rear equipment rack posts. Secure the rear-mount rail brackets to your equipment rack with two rack mount screws each, as shown in [Figure 8 on page 86](#).

**Figure 8: Front-and-Rear Mounting Recessed in a Rack**

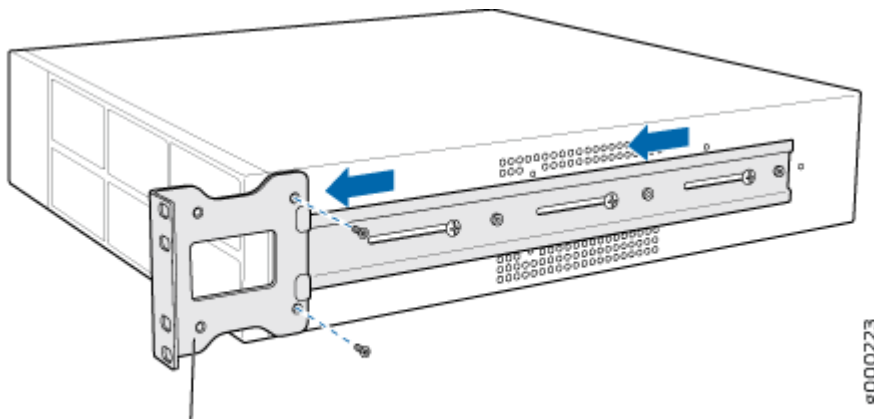

**Mounting bracket, positioned forward for recessed mounting.**

- Insert locking screws on the sides of the rear-mount brackets to secure the front and rear mounting brackets in place.
- Verify that the mounting screws on one side of the rack are aligned with the mounting screws on the opposite side and that the appliance is level.

The recessed position allows network and console cables to be routed through the sides of the equipment rack and through the holes of the recessed front rails on either side of the unit. This enables easy cable routing on the racks with limited cable management.

## RELATED DOCUMENTATION

[Front-and-Rear Mounting the JA2500 Junos Space Appliance Flush to a Rack | 84](#)

[Junos Space Appliance Rack Requirements | 21](#)

[Midmounting the Junos Space Appliance in a Two-Post Rack | 86](#)

[Tools and Parts Required to Install the Junos Space Appliance | 81](#)

## Midmounting the Junos Space Appliance in a Two-Post Rack

This option is suitable for a two-post equipment rack. It allows the appliance to be mounted so that there is even clearance on the front and rear of the rack.

To mount the appliance in a two-post rack, do the following:

1. Remove the two front-mount rails from either side of the chassis.
2. Insert one midmount bracket to the center on either side of the chassis.
3. Attach the chassis to the equipment rack and insert the other two midmount brackets on either side of the appliance to secure the chassis to the backs of the post, as shown in [Figure 9 on page 87](#).

**Figure 9: Midmounting in a Two-Post Rack**

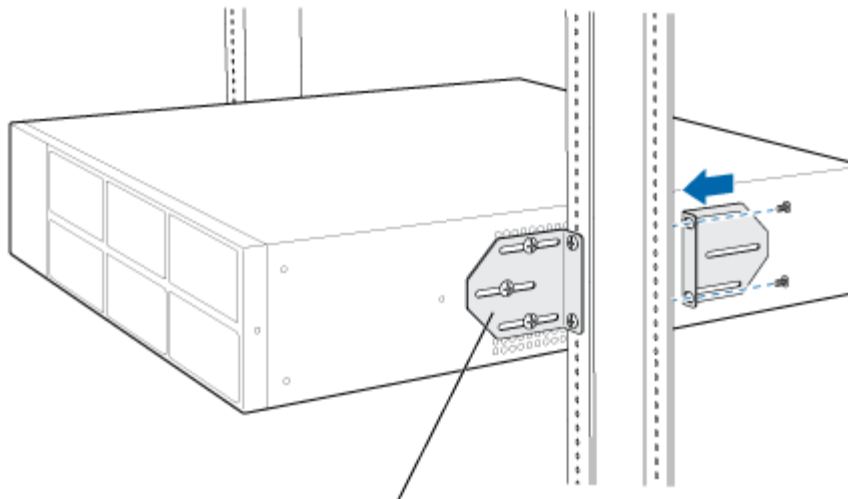

Attach the front bracket to the chassis, and secure the chassis to the post. Attach the rear bracket to the other side of the post, and secure the chassis to the rear bracket, adjusting the bracket width as needed.

8000225

4. Verify that the mounting screws on one side of the rack are aligned with the mounting screws on the opposite side and that the appliance is level.

#### RELATED DOCUMENTATION

[Front-and-Rear Mounting the JA2500 Junos Space Appliance Flush to a Rack | 84](#)

[Front-and-Rear Mounting the JA2500 Junos Space Appliance Recessed in a Rack | 85](#)

[Junos Space Appliance Rack Requirements | 21](#)

[Tools and Parts Required to Install the Junos Space Appliance | 81](#)

# Connecting the Appliance

## IN THIS CHAPTER

- [Connecting AC Power to the Junos Space Appliance | 88](#)
- [Connecting DC Power to the Junos Space Appliance | 90](#)
- [Connecting a Junos Space Appliance to the Network | 93](#)
- [Connecting a Junos Space Appliance to a Management Console | 94](#)

## Connecting AC Power to the Junos Space Appliance

Before you begin connecting AC power to a Junos Space Appliance:

- Ensure that you have grounded the appliance.



**CAUTION:** Grounding for Junos Space Appliances is provided through the power supply ground. Ensure that you connect the AC power supply module in the appliance into a grounded AC power outlet by using an AC power cord (with the grounding pin) appropriate for your geographical location. (See ["AC Power Cord Specifications for Junos Space Appliances" on page 23](#) for more information).

- Install the power supply module in the chassis. For instructions on installing a power supply module in a Junos Space Appliance, refer to the ["Replacing the AC Power Supply Module on a Junos Space Appliance" on page 164](#) topic.

**NOTE:** Each power supply module must be connected to a dedicated power source outlet.

Ensure that you have the following parts and tools available:

- (Optional) Electrostatic discharge (ESD) grounding strap
- A power cord appropriate for your geographical location



To connect AC power to the Junos Space Appliance, do the following:

1. (Optional) Attach an electrostatic discharge (ESD) grounding strap to your bare wrist and connect the strap to an external ESD point.
2. Ensure that the power supply module is fully inserted into the chassis.
3. Squeeze the two sides of the power cord retainer clip and insert the L-shaped ends of the wire clip into the holes in the bracket on each side of the AC power cord inlet on the faceplate of the AC power supply module, as shown in [Figure 10 on page 89](#).

**Figure 10: Connecting an AC Power Supply Module**

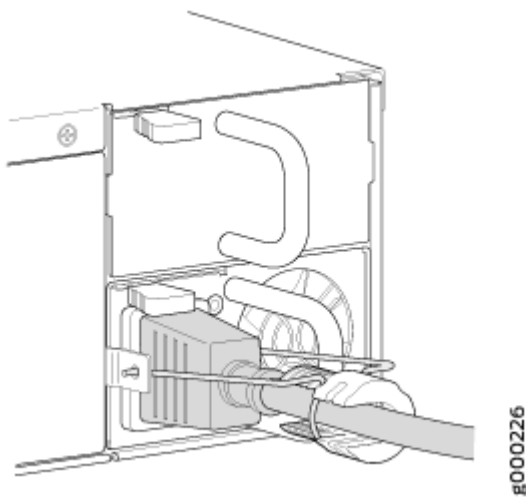

4. Locate the power cord or cords shipped with the appliance; the cords have plugs appropriate for your geographical location



**WARNING:** Ensure that the power cord does not block access to appliance components or drape where people can trip on it.

5. Insert the coupler end of the power cord into the AC power cord inlet on the faceplate of the AC power supply module.
6. Push the cord into the slot in the adjustment nut of the power cord retainer. Turn the nut until it is tight against the base of the coupler and the slot in the nut is turned 90° from the top of the appliance, as shown in [Figure 10 on page 89](#).
7. If the AC power source outlet has a power switch, set it to the OFF position.
8. Insert the power cord plug into an AC power source outlet.
9. If the AC power source outlet has a power switch, set it to the ON position.

The Junos Space Appliance starts powering on when you supply power to the power supply module. If the power supply module is correctly installed and functioning normally, the LED on the power supply module displays green when the power supply module is powering the appliance, and amber when the power supply module is in standby mode (not powering the appliance).

## RELATED DOCUMENTATION

[AC Power Supply in Junos Space Appliances | 25](#)

[General Electrical Safety Guidelines and Warnings | 65](#)

[Preventing Electrostatic Discharge Damage | 67](#)

[Replacing the AC Power Supply Module on a Junos Space Appliance | 164](#)

## Connecting DC Power to the Junos Space Appliance

Before connecting the Junos Space Appliance to a DC power source, do the following:

- Ensure that you have read the guidelines in the "[DC Power Electrical Safety Guidelines](#)" on page 71 topic.
- Ensure that you have taken the necessary precautions to prevent ESD damage.
- Ensure that you have grounded the appliance by connecting the DC power supply grounding cable to earth ground.



**CAUTION:** Before you connect power to the Junos Space Appliance, in order to meet the safety requirements and ensure proper operation, get a licensed electrician to attach a cable lug to the grounding and power cables that you supply. A cable with an incorrectly attached lug can damage the appliance (for example, by causing a short circuit).

- Ensure that you have the following parts and tools available:
  - (Optional) Electrostatic discharge (ESD) grounding strap
  - DC power source cables (12-14 AWG) with ends of the wire stripped ~12mm and twisted
  - Phillips (+) screwdriver, number 1

You connect DC source power to the appliance by attaching power cables from external DC power sources to the terminal studs on the DC power supply module faceplates.



**WARNING:** DC-powered Junos Space Appliances are intended for installation only in restricted access locations.



**WARNING:** Before you perform the following procedure, ensure that power is removed from the DC circuit. To ensure that all power is off, locate the circuit breaker on the panel board that services the DC circuit, switch the circuit breaker to the OFF position, and tape the switch handle of the circuit breaker in the OFF position.

To connect the DC source power to the Junos Space Appliance, do the following:

1. (Optional) Attach an electrostatic discharge (ESD) grounding strap to your bare wrist and connect the strap to an external ESD point.
2. Ensure that the power supply module is fully inserted in the chassis.
3. Ensure that the input circuit breaker is open so that the voltage across the DC power source cable leads is 0 V and that the cable leads will not become active when you connect the DC power.
4. Remove the clear plastic cover protecting the terminal on the faceplate.
5. Remove the screws on the terminals by using the screwdriver. Save the screws.
6. Connect the stripped and twisted wires to wire clamps under the DC terminal screws as shown in [Figure 11 on page 91](#).

**Figure 11: Connecting a DC Power Supply Module**

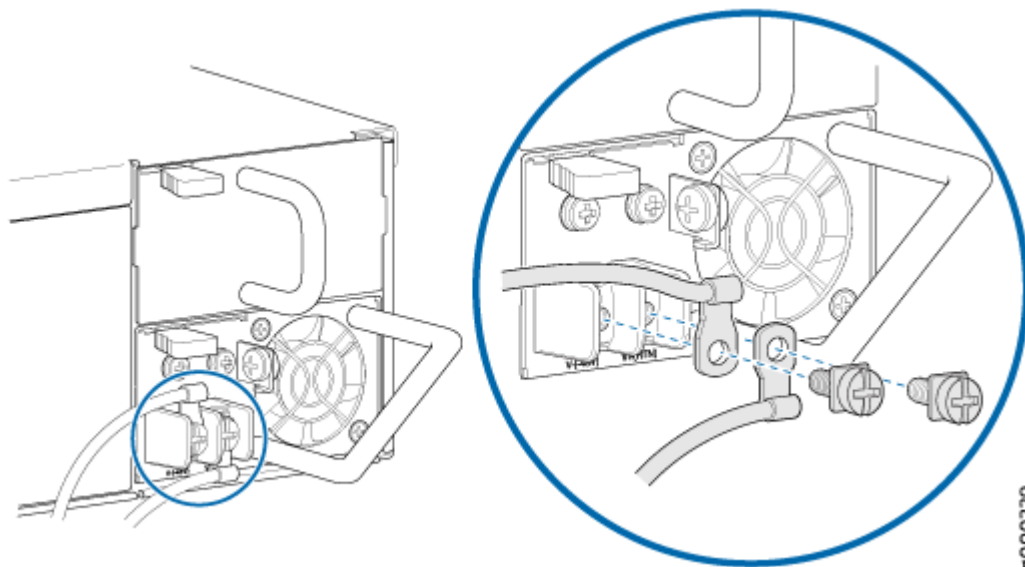

7. Use the terminal screws to secure the power source cables to the power feed on the appliance by attaching the twisted wires that are attached to the cables to the appropriate terminals.
8. Remove the screw on the grounding terminal by using the screwdriver. Save the screw.  
The grounding terminal is located to the right and above the terminals, as shown in [Figure 12 on page 92](#).

**Figure 12: DC Power Supply Grounding**

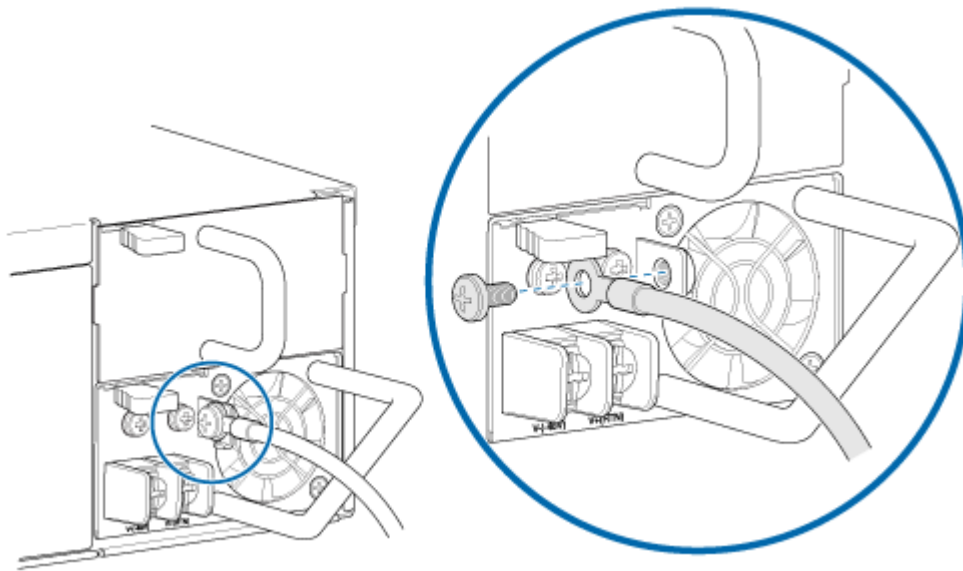

9. Connect the grounding lug to the earthing terminal using the screw, as shown in [Figure 12 on page 92](#).
10. Attach the plastic safety cover.
11. Close the input circuit breaker.

The Junos Space Appliance starts powering on when you supply power to the power supply module. If the power supply module is correctly installed and functioning normally, the LED on the power supply module displays green when the power supply module is powering the appliance, and amber when the power supply module is in standby mode (not powering the appliance).

## RELATED DOCUMENTATION

[DC Power Grounding Requirements and Warning | 74](#)

[DC Power Supply in Junos Space Appliances | 27](#)

[General Electrical Safety Guidelines and Warnings | 65](#)

[DC Power Disconnection Warning | 72](#)

[DC Power Wiring Sequence Warning | 75](#)

[DC Power Wiring Terminations Warning | 76](#)

[Preventing Electrostatic Discharge Damage | 67](#)

## Connecting a Junos Space Appliance to the Network

Though the Junos Space Appliance has four Ethernet interfaces, only three can be used; one of the Ethernet interface is reserved for future use. On the JA2500 appliance, the Ethernet interfaces that can be used are labeled **0**, **1**, and **3**. The **2** Ethernet interface is reserved for future use.

For more information about Junos Space Ethernet interfaces, see "[Junos Space Ethernet Interfaces Overview](#)" on page 4.

To connect the appliance to the network, do the following:

1. (Optional) Attach an electrostatic discharge (ESD) grounding strap to your bare wrist and connect the strap to an external ESD point.
2. Plug one end of the Ethernet cable into the port labeled **0**, as shown in [Figure 13 on page 93](#), on the front panel.

**Figure 13: JA2500 Appliance Front Panel**

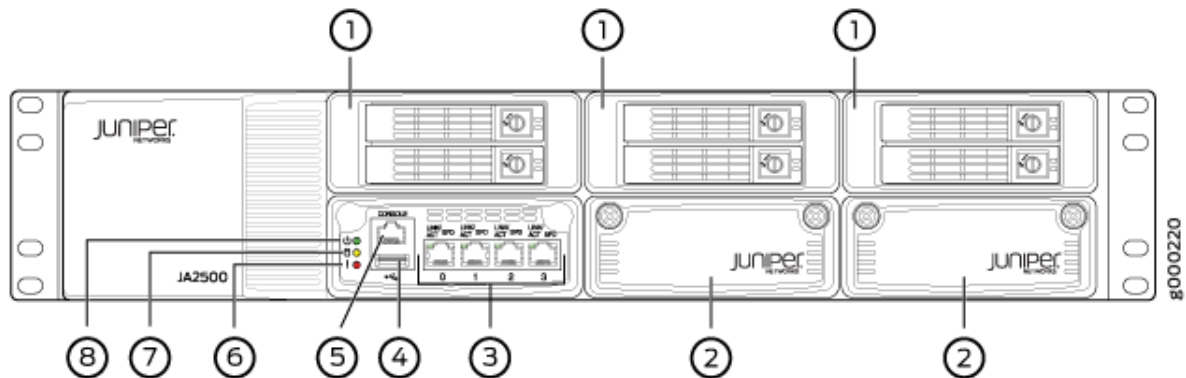

3. (Optional) If you are using eth1 interface, take an Ethernet cable and plug one end of the Ethernet cable into the port labeled **1** and the other end into the network that contains the Junos Space nodes in the fabric.
4. Plug the other end of the Ethernet cable into the network.

**NOTE:** If you choose to connect the JA2500 appliance to more than one Ethernet interfaces, then you should plug the other end of the Ethernet cable into the network that contains the Web UI clients and the other Junos Space nodes in the fabric.

## RELATED DOCUMENTATION

[Connecting a Junos Space Appliance to a Management Console | 94](#)

[Booting the Junos Space Appliance | 96](#)

## Connecting a Junos Space Appliance to a Management Console

You can configure and manage a Junos Space Appliance by using a dedicated console. Every appliance has a console port with an RJ-45 connector. Use the console port to connect the appliance to the management console or to a console server. Ensure that you have an Ethernet cable with an RJ-45 connector available. An RJ-45 cable, as shown in [Figure 14 on page 94](#), and an RJ-45 to DB-9 serial port adapter are supplied with the appliance.

**Figure 14: Ethernet Cable Connector**

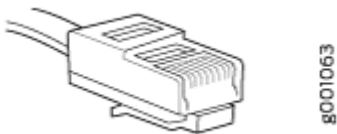

To connect the appliance to a management console, do the following:

1. Connect the RJ-45 to DB-9 serial port adapter to the serial port of the management device (laptop or PC) that you will use to access the Junos Space CLI.

**NOTE:** If your laptop or PC does not have a DB-9 plug connector pin and you want to connect your laptop or PC directly to the appliance, use a combination of the RJ-45 to DB-9 socket adapter supplied with the appliance and a USB to DB-9 plug adapter. You must provide the USB to DB-9 plug adapter.

2. Connect one end of the Ethernet cable into the console port (labeled **CONSOLE**) on the front panel of the appliance.

3. Connect the other end of the Ethernet cable into the RJ-45 to DB-9 serial port adapter.

#### RELATED DOCUMENTATION

[Connecting a Junos Space Appliance to the Network | 93](#)

---

[Booting the Junos Space Appliance | 96](#)

---

[Chassis Console Port Pinouts | 14](#)

# Performing Initial Configuration

## IN THIS CHAPTER

- [Booting the Junos Space Appliance | 96](#)
- [Configuring a Junos Space Appliance as a Junos Space Node | 97](#)
- [Configuring a Junos Space Appliance as a Standalone or Primary FMPM Node | 123](#)
- [Configuring a Junos Space Appliance as a Backup or Secondary FMPM Node for High Availability | 134](#)
- [Installing a Junos Space Image on a Junos Space Appliance by Using a USB Drive | 142](#)
- [Powering Off the Junos Space Appliance | 148](#)

## Booting the Junos Space Appliance

Before you begin booting the Junos Space Appliance, ensure that you have:

- Connected the Junos Space Appliance to a management console.
- Configured a console terminal or terminal emulation utility to use the following serial connection parameters:
  - Baud rate: 9600 bits per second
  - Data: 8 bits
  - Flow control: None
  - Parity: None
  - Stop bits: 1

**NOTE:** If you have turned on power to the power supply module, then the Junos Space Appliance starts booting automatically.

To boot the Junos Space Appliance, do the following:



1. Power on the management device (PC or laptop) that is connected to the appliance's console port.
2. Power on the appliance by toggling the power switch located at the rear panel of the appliance.

The appliance is shipped with a version of the Junos Space Network Management Platform software installed. When the appliance is powered on, the serial console displays diagnostic information before booting. When booting is complete, the serial console displays the login prompt. You are now ready to configure basic settings on the appliance.

## RELATED DOCUMENTATION

[Connecting a Junos Space Appliance to a Management Console | 94](#)

[Configuring a Junos Space Appliance as a Junos Space Node | 97](#)

[Configuring a Junos Space Appliance as a Standalone or Primary FMPM Node | 123](#)

[Installing a Junos Space Image on a Junos Space Appliance by Using a USB Drive | 142](#)

[Powering Off the Junos Space Appliance | 148](#)

## Configuring a Junos Space Appliance as a Junos Space Node

### IN THIS SECTION

- [Configuring a Junos Space Appliance as a Junos Space Node | 100](#)
- [Configuring Access to Junos Space Through a NAT Gateway | 116](#)
- [Configuring the eth1 Interface | 122](#)

You can configure a Junos Space Appliance as a Junos Space node or as a specialized node used for fault monitoring and performance monitoring (FMPM). To configure a Junos Space Appliance as a Junos Space node, you must configure basic network and system settings to make the appliance accessible on the network.

### NOTE:

- From Junos Space Network Management Platform Release 14.1R2 onward, you can configure Junos Space Ethernet interfaces with only IPv4 addresses, or both IPv4 and IPv6 addresses.

- From Junos Space Network Management Platform Release 16.1R1 onward, you can configure access to Junos Space through a Network Address Translation (NAT) gateway.

The disk space allocation for a JA2500 Junos Space Appliances is as follows:

- 1.2 TB for **/var**
- 715 GB for **/var/log**
- 92 GB for **/tmp**
- 92 GB for **/**

Before you begin, do the following:

- Ensure that the Junos Space Appliance is connected to a management console and that the management device is powered on.
- Ensure that the appliance is booted and displays the login prompt at the console.
- Ensure that you have the following information available:
  - IPv4 address and subnet mask for the node management (eth0) Ethernet interface
  - (Optional) IPv6 address and prefix for the eth0 Ethernet interface
  - IPv4 address of the default gateway for the eth0 Ethernet interface
  - (Optional) IPv6 address of the default gateway for the eth0 Ethernet interface
  - IPv4 address of the name server
  - (Optional) IPv6 address of the name server
  - (Optional) IPv4 address and subnet mask for the Ethernet interface eth3, if you are configuring a device management interface

**NOTE:** When you configure the eth3 interface as the device management interface, the IP addresses of the eth0 and eth3 Ethernet interfaces must be in different subnets.

- (Optional) IPv4 address of the default gateway for the eth3 Ethernet interface

**NOTE:** If you configure the IPv4 address for the eth3 Ethernet interface, you must configure the IPv4 address of the default gateway.

- (Optional) IPv6 address and prefix for the eth3 Ethernet interface
- (Optional) IPv6 address of the default gateway for the eth3 Ethernet interface

**NOTE:** If you configure the IPv6 address for the eth3 Ethernet interface, you must configure the IPv6 address of the default gateway for the eth3 interface.

- Virtual IP (VIP) address in IPv4 and IPv6 formats

The IPv4 format of the VIP address is used for accessing the Junos Space Network Management Platform GUI through a Web browser. This IP address must be in the same subnet as the IP address assigned to the eth0 Ethernet interface

The IPv6 format of the VIP address is used for receiving SNMP traps from managed devices.

- IPv4 address or URI of the NTP source to synchronize time
- (Optional) IPv4 address of the eth1 Ethernet interface

If the IP address of the eth1 interface is not in the same subnet as the VIP address, ensure that you have the subnet mask and the default gateway for the eth1 interface.

- (Optional) IPv4 address for the NAT outbound SSH
- (Optional) IPv6 address for the NAT outbound SSH
- (Optional) IPv4 port number for the NAT outbound SSH
- (Optional) IPv6 port number for the NAT outbound SSH
- (Optional) IPv4 address for the NAT trap
- (Optional) IPv6 address for the NAT trap
- (Optional) IPv4 port number for the NAT trap
- (Optional) IPv6 port number for the NAT trap

This topic discusses the following tasks:

## Configuring a Junos Space Appliance as a Junos Space Node

You can configure the Junos Space Appliance as a Junos Space node.

To configure a Junos Space Appliance as a Junos Space node:

1. At the serial console login prompt, type the default username (`admin`) and press Enter.
2. Type the default password (`abc123`) and press Enter.  
You are prompted to change your password.
3. To change the default password, do the following:
  - a. Type the default password and press Enter.
  - b. Type your new password and press Enter.
  - c. Retype your new password and press Enter.

If the password is changed successfully, the message `passwd: all authentication tokens updated successfully` is displayed.

### NOTE:

- All passwords are case-sensitive.
- You can choose a password that is at least eight characters long, and that contains characters from at least three of the following four character classes: uppercase letters, lowercase letters, numbers (0 through 9), and special characters.

However, if a password satisfies the preceding criteria but contains only a single uppercase letter at the beginning or only a single number at the end, then that password is considered invalid. In order to be counted as a valid character class, a single uppercase letter must not be at the beginning of the password, and a single number must not be at the end. For example, `Abcdwip9`, `Qc9rdiwt`, and `bRfjvin9` are invalid passwords, but `AAbcdwip99`, `Qc9rdiwtQ`, and `bRfjvin99` are valid passwords.

- Alternatively, instead of using a string of characters, you can choose a passphrase that is between 16 and 40 characters long, and contains at least three dictionary words separated by at least one special character. For example, `big#three;fork` (14 characters long) and `circlefaceglass` (no special characters) are invalid passphrases, but `@big#three;fork&` and `circle;face;glass` are valid passphrases.
4. Type the new password to log in to the appliance and press Enter.
  5. Type `S` to proceed with the configuration of the appliance as a Junos Space node with full Junos Space Network Management Platform functionality. Every Junos Space installation requires at least one Junos Space node.

6. Configure the IP address for the eth0 interface.

```
Configuring Eth0:  
  
1> Configure IPv4  
2> Configure Both IPv4 and IPv6  
  
R> Redraw Menu  
  
Choice [1-2,R]:
```

**NOTE:** If you are configuring the appliance as part of a cluster (fabric), then all nodes in that fabric must be in the same subnet.

For more information about the Junos Space fabric, refer to the *Managing Nodes in the Junos Space Fabric* chapter in the *Junos Space Network Management Platform Workspaces Feature Guide* (available at [http://www.juniper.net/techpubs/en\\_US/release-independent/junos-space/index.html](http://www.juniper.net/techpubs/en_US/release-independent/junos-space/index.html)).

- To configure the IPv4 address of the eth0 interface:
  - a. Type **1**.
  - b. Type the IPv4 address for eth0 interface in dotted-decimal notation and press Enter.

```
Please enter new IPv4 address for interface eth0:  
192.0.2.50
```

- c. Type the subnet mask for the IPv4 address and press Enter.

```
Please enter new IPv4 subnet mask for interface eth0:  
255.255.0.0
```

- d. Type the IPv4 address of the default gateway for the eth0 Ethernet interface in dotted-decimal notation and press Enter.

```
Enter the default IPv4 gateway as a dotted-decimal IP Address:  
192.0.2.150
```

- To configure both IPv4 and IPv6 addresses:
  - a. Type 2.
  - b. Type the IPv4 address for the eth0 interface in dotted-decimal notation and press Enter.

```
Please enter new IPv4 address for interface eth0
192.0.2.50
```

- c. Type a subnet mask for the IPv4 address in dotted-decimal notation and press Enter.

```
Please enter new IPv4 subnet mask for interface eth0:
255.255.0.0
```

- d. Type the IPv4 address of the default gateway for the eth0 interface in dotted-decimal notation and press Enter.

```
Enter the default IPv4 gateway as a dotted decimal IP Address:
192.0.2.150
```

- e. Type the IPv6 address and prefix for the eth0 interface and press Enter.

```
Please enter new IPv6 address with prefix (IPv6 Address/prefix) for interface eth0:
2001:db8:0:1:192:0:2:50/64
```

**NOTE:** If you configure an IPv6 address for the eth0 interface, you must configure an IPv6 address for the name server.

- f. Type the IPv6 address of the default gateway for the eth0 interface and press Enter.

```
Enter the IPv6 gateway:
2001:db8:0:1:192:0:2:150
```

7. Type the IPv4 address of the name server for the eth0 interface and press Enter.

```
Please type the IPv4 nameserver address in dotted decimal notation:
192.0.2.10
```

8. Type the IPv6 address of the name server for the eth0 interface and press Enter.

```
Please type the IPv6 nameserver address:
2001:db8:0:1:192:0:2:10
```

9. Specify whether you want to configure a separate interface for device management or not:

**NOTE:**

- On a Junos Space fabric with two or more Junos Space nodes, if you configure the eth3 interface as the device management interface on one Junos Space node, then you must also configure the eth3 interface as the device management interface on all the other Junos Space nodes in that fabric.
  - When you configure the eth3 interface as the device management interface, the IP addresses of the eth0 and eth3 Ethernet interfaces must be in different subnets.
- Type Y if you want to use a different Ethernet interface (eth3) to manage devices.

```
Configuring device management interface eth3:
```

```
1> Configure IPv4
2> Configure IPv6
3> Configure Both IPv4 and IPv6
```

```
R> Redraw Menu
```

```
Choice [1-3,R]:
```

- To configure the IPv4 address of the eth3 interface:
  - a. Type 1.

- b. Type the IPv4 address for eth3 interface in dotted-decimal notation and press Enter.

```
Please enter new IPv4 address for interface eth3:  
192.0.2.55
```

- c. Type the new subnet mask of the IPv4 address in dotted-decimal notation and press Enter.

```
Please enter new IPv4 subnet mask for interface eth3:  
255.255.0.0
```

- d. Type the IPv4 address of the default gateway for the eth3 Ethernet interface in dotted-decimal notation and press Enter.

```
Enter the default IPv4 gateway for this interface:  
192.0.2.75
```

- e. Type the IPv4 address of the name server for the eth3 interface and press Enter.

```
Please type the IPv4 nameserver address in dotted decimal notation:  
192.0.2.105
```

- To configure the IPv6 address of the eth3 interface:

- a. Type 2.

- b. Type the IPv6 address with prefix for the eth3 interface and press Enter.

```
Please enter new IPv6 address with prefix (IPv6 Address/prefix) for interface eth3:  
2001:db8:20:1:192:20:2:50/64
```

- c. Type the IPv6 address of the default gateway for the eth3 interface and press Enter.

```
Enter the default IPv6 gateway for this interface:  
2001:db8:20:1:192:20:2:150
```



- d. Type the IPv6 address of the name server for the eth3 interface and press Enter.

```
Please type the IPv6 nameserver address:  
2001:db8:20:1:192:0:2:10
```

- To configure both IPv4 and IPv6 addresses:

- a. Type 3.

- b. Type the IPv4 address for the eth3 interface in dotted-decimal notation and press Enter.

```
Please enter new IPv4 address for interface eth3:  
192.0.2.55
```

- c. Type a subnet mask for the IPv4 address in dotted-decimal notation and press Enter.

```
Please enter new IPv4 subnet mask for interface eth3:  
255.255.0.0
```

- d. Type the IPv4 address of the default gateway for the eth3 interface in dotted-decimal notation and press Enter.

```
Enter the default IPv4 gateway for this interface:  
192.0.2.75
```

- e. Type the IPv6 address and prefix for the eth3 interface and press Enter.

```
Please enter new IPv6 address with prefix (IPv6 Address/prefix) for interface eth3:  
2001:db8:20:1:192:20:2:50/64
```

**NOTE:** You must provide an IPv6 address for the name server if you configure an IPv6 address for the eth3 interface.

- f. Type the IPv6 address of the default gateway for the eth3 interface and press Enter.

```
Enter the default IPv6 gateway for this interface:
2001:db8:20:1:192:20:2:150
```

- g. Type the IPv4 address of the name server for the eth3 interface and press Enter.

```
Please type the IPv4 nameserver address in dotted decimal notation:
192.0.2.105
```

- h. Type the IPv6 address of the name server for the eth3 interface and press Enter.

```
Please type the IPv6 nameserver address:
2001:db8:20:1:192:0:2:10
```

- Type **N** if you want to use only the Ethernet interface eth0 to manage devices and the Junos Space Web clients.
10. Specify whether the appliance is to be added to an existing cluster (fabric) or is the first node in a cluster:
- To add the appliance to an existing cluster, type **y**.

If you are configuring an appliance with a Junos Space Network Management Platform Release 16.1 or later installation, you are prompted to specify whether you want to configure NAT. Follow the procedure outlined in ["Configuring Access to Junos Space Through a NAT Gateway" on page 116](#).

- To configure the appliance as a standalone node, type **n**.

You are prompted to enter the IP address for Web access.

```
Configuring IP address for web GUI:

1> Configure Both IPv4 and IPv6

R> Redraw Menu

Choice [1,R]: 1
```

**NOTE:** If you configure only an IPv4 address for the eth0 interface, you are provided with an option to configure only the IPv4 address for Web access.

- a. Type **1** to configure the IPv4 and IPv6 addresses that will be used to access Junos Space Platform through a browser.

**NOTE:** The IP address for Web access must be in the same subnet as the IP address for the eth0 interface, but must be a different IP address.

- b. Type the IPv4 address in dotted-decimal notation and press Enter.

```
Please enter IPv4 address for web GUI:
192.0.2.75
```

- c. Type the IPv6 address and press Enter.

```
Please enter new IPv6 address for web GUI:
2001:db8:0:1:192:0:3:50
```

If you are configuring an appliance with a Junos Space Network Management Platform Release 16.1 or later installation, you are prompted to specify whether you want to configure NAT. Follow the procedure outlined in ["Configuring Access to Junos Space Through a NAT Gateway" on page 116.](#)

For releases prior to Junos Space Network Management Platform Release 16.1R1, you are prompted to configure the NTP server. Go to ["10.d" on page 107.](#)

- d. Specify whether you want to configure the NTP server and time for the Junos Space node:

```
Add NTP Server? [y/n]
```

- To skip configuring the NTP server:

- i. Type **n**.

The current time of the Space node is displayed. You can edit the time or leave it as is.

- ii. Press Enter.
- To configure the NTP server:
  - i. Type `y` to synchronize the node with an external NTP server and press Enter.  
You are prompted to enter the new NTP server.
  - ii. Enter the IP address or the URI of the NTP server.

```
Please type the new NTP server: device1.example.com
```

On successful addition of the NTP server, a message appears as shown in the following sample:

```
Added device1.example.com
```

You are prompted to enter a display name for the node.

- e. Type a display name for this node and press Enter.

```
Please enter display name for this node: jsnode1
```

This is the name that Junos Space displays for the first node in a Junos Space cluster.

- f. Type the password for cluster maintenance mode and press Enter.

```
Enter password for cluster maintenance mode:
```

**NOTE:**

- You can choose a password that is at least eight characters long and contains characters from at least three of the following four character classes: uppercase letters, lowercase letters, numbers (0 through 9), and special characters. `Ab(3)def`, `o0*wwrty`, and `9Rtsgukj` are some examples of valid password for maintenance mode.

- When you configure the other nodes in a cluster (fabric), you are not prompted to enter a maintenance-mode password. The maintenance-mode password that you specify when you configure the first node of the cluster is applicable to all other nodes in that cluster (fabric); in other words, the entire cluster of nodes has the same maintenance-mode password.

You are prompted to retype the password.

```
Re-enter password:
```

**g.** Retype the password for cluster maintenance mode and press Enter.

- For releases prior to Junos Space Network Management Platform Release 16.1R1, the Settings Summary is displayed. Go to ["10.i" on page 114](#).
- For a Junos Space Platform Release 16.1R1 or 16.1R2 installation, you are prompted to specify whether you want to restore backed up data. Go to ["10.h" on page 109](#)

```
Do you want to restore Space backup? [Y/N]:
```

**h.** Perform one of the following actions depending on whether you are upgrading Junos Space Platform on the node or configuring a fresh Junos Space node.

- Type **Y** to restore backed up data if you are upgrading Junos Space Platform.

A message is displayed, warning you to wait till the backed up data is completely restored and all required Junos Space services are started on the node before attempting to access the Web GUI.

The Settings Summary is displayed, as shown in the following example:

```
Settings Summary:
```

```
> IPv4 Change: eth0 is 192.168.26.151 / 255.255.254.0
> Default IPv4 Gateway = 192.168.27.10 on eth0
> IPV6 Change: eth0 is 2001:db8:85a3:0:0:8a2e:c0a9:1b37 / 64
> Default IPv6 Gateway = 2001:db8:85a3:0:0:8a2e:c0a9:1bbd on eth0
> IPv4 DNS add: 192.168.27.2
> DNS add: 2001:db8:85a3:0:0:8a2e:c0a9:1bbd
> Create as first node or standalone
> Web IPv4 address 192.168.26.152
```

```

> Web IPv6 address is 2001:db8:85a3:0:0:8a2e:c0a9:1b38/64
> NTP add: device1.example.com
> NAT IPv4 Outbound SSH IP: 192.168.130.2
> NAT IPv4 Outbound SSH Port: 5051
> NAT IPv4 Trap IP: 192.168.130.2
> NAT IPv4 Trap Port: 5052
> NAT IPv6 Outbound SSH IP: 2001:db8:85a3:0:0:130:0:2
> NAT IPv6 Outbound SSH Port: 5053
> NAT IPv6 Trap IP: 2001:db8:85a3:0:0:130:0:2
> NAT IPv6 Trap Port: 5054
> Node display name is "node1"
> Password for Junos Space maintenance mode is set.

A> Apply settings
C> Change settings
Q> Quit and set up later
R> Redraw Menu

Choice [ACQR]:

```

- i. Type **A** and press Enter to apply settings.

You are prompted to specify the location from where you want to restore the backup.

```

1> Remote Server
2> USB
3> Local

M> Return to Main Menu
R> Redraw Menu

Choice [1-3 MR]:

```

- ii. Select one of the following options depending on where the backup file is stored:
  - To restore from a remote SCP server:
    1. Type **1** and press Enter.

You are prompted to confirm if you want to proceed with the backup from the remote server.

```
You have selected [ Remote Server ]. Do you want to Continue? [Y/N]:
```

2. Type **Y** to continue.

You are prompted to enter the IPv4 address of the remote server.

```
Please enter Remote Server IP:
```

3. Type the IPv4 address of the remote server and press Enter.

You are prompted to enter the port number of the remote server.

```
Please enter port number for Remote Server <Remote server IP address>:
```

4. Enter the port number of the remote server and press Enter.

You are prompted to enter the username to access the remote server.

```
Please enter Remote Server <Remote server IP address> user:
```

5. Type the username and press Enter.

You are prompted to enter the password of the user.

```
Please enter Remote Server user <Remote server user> password
```

6. Type the password and press Enter.

You are prompted to enter the full path of the directory where the backup file is stored.

```
Enter the path of the directory containing backup files:
```

7. Type the full path of the directory and press Enter.

The messages displayed on the console indicate whether the data is restored successfully to the Junos Space node.

- To restore from a USB storage device:

**NOTE:** Before you restore from a USB storage device, you must ensure that the USB storage device is plugged-in and mounted to the path `/tmp/pendrive`.

1. Type **2** and press Enter to restore the backup from the USB storage device.

You are prompted to confirm if you want to proceed with the backup from the USB storage device.

```
You have selected [ USB ]. Do you want to Continue? [Y/N]:
```

2. Type **Y** to continue.

The messages displayed on the console indicate whether the data is restored successfully to the Junos Space node.

3. Unmount the USB storage device by typing the following command:

```
umount /tmp/pendrive
```

You can unplug the USB storage device after you unmount it.

- To restore from a local drive:

**NOTE:** To restore data from a local drive, you must first copy the backup file from the backup location to the Junos Space node.

1. Type **3** and press Enter.

You are prompted to confirm if you want to proceed with the backup from the local drive.

```
You have selected [ Local ]. Do you want to Continue? [Y/N]:
```

2. Type **Y** to continue.



You are prompted to enter the full path of the directory where the back up file is stored.

```
Enter the tar file path to restore from local :
```

**3.** Type the full path of the directory and press Enter.

The messages displayed on the console indicate whether the data is restored successfully to the Junos Space node.

When the data is restored successfully, JBoss services are started on the node and you can access the Junos Space Platform UI through a browser by using the virtual IP (VIP) address configured for Web access.

The Junos Space Settings menu is displayed at this point of time after the data is restored and the services restarted.

- Type **N** if you are configuring the first node of a fresh Junos Space Platform Release 16.1 or later installation and not upgrading Junos Space Platform.

A message indicating that you have opted for a fresh installation of Junos Space Platform is displayed. You are prompted to specify whether you want to continue.

```
You have chosen for fresh installation, backup taken from 15.2R2 will not be
restored. Do you want to still proceed with fresh installation?
```

- Perform one of the following actions:
  - Type **Y** to proceed with the fresh installation.
  - Type **N** if you do not want to proceed with the fresh installation.

You are prompted to specify whether you want to restore backed up data.

```
Do you want to Restore Space Backup?
```

- Type **Y** to restore backed up data. Go to Step "[10.h](#)" on page 109.
- Type **N** to proceed with the fresh installation.

You are again prompted to confirm whether you want to proceed with a fresh installation. Type **Y** to confirm.

The Settings Summary is displayed, as shown in the following example:

```
Settings Summary:

> IPv4 Change: eth0 is 192.168.26.151 / 255.255.254.0
> Default IPv4 Gateway = 192.168.27.10 on eth0
> IPv6 Change: eth0 is 2001:db8:85a3:0:0:8a2e:c0a9:1b37 / 64
> Default IPv6 Gateway = 2001:db8:85a3:0:0:8a2e:c0a9:1bbd on eth0
> IPv4 DNS add: 192.168.27.2
> DNS add: 2001:db8:85a3:0:0:8a2e:c0a9:1bbd
> Create as first node or standalone
> Web IPv4 address 192.168.26.152
> Web IPv6 address is 2001:db8:85a3:0:0:8a2e:c0a9:1b38/64
> NTP add: device1.example.com
> NAT IPv4 Outbound SSH IP: 192.168.130.2
> NAT IPv4 Outbound SSH Port: 5051
> NAT IPv4 Trap IP: 192.168.130.2
> NAT IPv4 Trap Port: 5052
> NAT IPv6 Outbound SSH IP: 2001:db8:85a3:0:0:130:0:2
> NAT IPv6 Outbound SSH Port: 5053
> NAT IPv6 Trap IP: 2001:db8:85a3:0:0:130:0:2
> NAT IPv6 Trap Port: 5054
> Node display name is "node1"
> Password for Junos Space maintenance mode is set.

A> Apply settings
C> Change settings
Q> Quit and set up later
R> Redraw Menu

Choice [ACQR]:
```

i. Perform one of the following actions:

- To apply the settings, type **A**.

The settings that you configured are applied and a series of messages is displayed on the console, and then the Junos Space Settings Menu is displayed as shown in the following example:

```
Junos Space Settings Menu

1> Change Password
2> Change Network Settings
3> Change Time Options
4> Retrieve Logs
5> Security
6> (Debug) run shell

A> Apply Settings
Q> Quit
R> Redraw Menu

Choice [1-6,QR]:
```

- To change the settings, type **C**.

You are prompted to reenter all the basic configuration information that you have configured up to this point.

- To quit the configuration without applying the settings, type **Q**.

The Junos Space Settings Menu is displayed.



**CAUTION:** If you quit the configuration without applying the settings, then all the settings are discarded.

- j. (Optional) If you have applied the settings, then type **Q** to exit the Junos Space Settings menu.

You are taken to the console login prompt.

**NOTE:**

- If you have specified that the Junos Space node is the first node in the fabric or a standalone node, you can access Junos Space Network Management Platform by typing the IP address configured for the Web GUI in a browser.
- If you have specified that the Junos Space node is part of an existing cluster (fabric), then you must add the Junos Space node to the Junos Space fabric using the Junos Space Network Management Web GUI. For more information, see the *Adding a Node to an Existing Junos Space Fabric* topic in the *Junos Space Network Management Platform Workspaces Feature Guide* (available at [http://www.juniper.net/techpubs/en\\_US/release-independent/junos-space/index.html](http://www.juniper.net/techpubs/en_US/release-independent/junos-space/index.html)).

## Configuring Access to Junos Space Through a NAT Gateway

You can choose to configure access to Junos Space through a NAT gateway when you are configuring a Junos Space appliance.

When prompted, specify whether you want to configure access to Junos Space using NAT.

Do you want to enable NAT service ? [Y/N]

- To configure NAT, type Y.

### NOTE:

- If you choose to configure NAT, the options that are displayed depend on the IP address or addresses that you have configured for the device management interface. If you have configured eth3 as the device management interface, then the options that are displayed will depend on the IP address or addresses configured for eth3. If eth3 is not configured, the displayed options will depend on the IP address configuration of the eth0 interface.
- If the device management interface is assigned an IPv4 address, you are prompted to enter the IPv4 address for the NAT interfaces. If the device management interface is assigned an IPv6 address, you are prompted to enter the IPv6 address for the NAT interfaces. If the device management interface is assigned an IPv4 address and an IPv6 address, you are prompted to select either IPv4, IPv6, or both for the NAT interfaces.
- If you are adding the node to an existing cluster and eth3 is configured, you are prompted to specify whether you want to configure the trap interface. You must choose to configure the trap interface, if you are adding the node as the standby VIP node. If eth3 is not configured for the node, you are not prompted to configure the trap interface.

You are prompted to configure NAT IP addresses.

```
1> Configure IPv4
2> Configure IPv6
3> Configure IPv4 and IPv6

R> Redraw Menu
Choice [1-3, R]:
```

- To configure the IPv4 address:
  1. Type **1** and press Enter.
  2. Type the IPv4 address of the NAT outbound SSH interface and press Enter.

```
Configuring NAT :

Configuring IPV4 OutboundSSH for NAT:

Please enter the NAT Outbound SSH IP Address
192.168.190.7
```

3. Type the port number of the NAT outbound SSH interface and press Enter.  
The port number must be in the range 0-65535.

```
Please enter the NAT Outbound SSH Port Number
4545
```

4. Type the IPv4 address of the NAT trap interface and press Enter.  
The IP address must be in the range 1.0.0.1 - 223.255.255.254 excluding 127.x.x.x.

```
Configuring IPV4 Trap for NAT:

Please enter the NAT Trap IP Address
192.168.27.1
```

5. Type the port number of the NAT trap interface and press Enter.

```
Please enter the NAT Trap Port Number
4584
```

- To configure the IPv6 address:

1. Type 2 and press Enter.
2. Type the IPv6 address of the NAT outbound SSH interface and press Enter.

```
Configuring NAT :

Configuring IPV6 OutboundSSH for NAT:

Please enter the NAT Outbound SSH IP Address
2001:db8:85a3::8a2e:130:0:2
```

3. Type the port number of the NAT outbound SSH interface and press Enter.

The port number must be in the range 0-65535.

```
Please enter the NAT Outbound SSH Port Number
5054
```

4. Type the IPv6 address of the NAT trap interface and press Enter.

The IP address must be in the range 1.0.0.1 - 223.255.255.254 excluding 127.x.x.x.

```
Configuring IPV6 Trap for NAT:

Please enter the NAT Trap IP Address
2001:db8:85a3::8a2e:130:0:2
```

5. Type the port number of the NAT trap interface and press Enter.

```
Please enter the NAT Trap Port Number

5054
```

- To configure IPv4 and IPv6:

1. Type **3** and press Enter.

2. Type the IPv4 address of the NAT outbound SSH interface and press Enter.

```
Configuring IPV4 OutboundSSH for NAT:
```

```
Please enter the NAT Outbound SSH IP Address  
192.168.190.7
```

3. Type the port number of the NAT outbound SSH interface and press Enter.

The port number must be in the range 0-65535.

```
Please enter the NAT Outbound SSH Port Number  
4545
```

4. Type the IPv4 address of the NAT trap interface and press Enter.

The IP address must be in the range 1.0.0.1 - 223.255.255.254 excluding 127.x.x.x.

```
Configuring IPV4 Trap for NAT:
```

```
Please enter the NAT Trap IP Address  
192.168.27.1
```

5. Type the port number of the NAT trap interface and press Enter.

The port number must be in the range 0-65535.

```
Please enter the NAT Trap Port Number  
4584
```

6. Type the IPv6 address of the NAT outbound SSH interface and press Enter.

```
Configuring IPV6 OutboundSSH for NAT:
```

```
Please enter the NAT Outbound SSH IP Address
2001:db8:85a3::8a2e:130:0:2
```

7. Type the port number of the NAT outbound SSH interface and press Enter.

The port number must be in the range 0-65535.

```
Please enter the NAT Outbound SSH Port Number
7075
```

8. Type the IPv6 address of the NAT trap interface and press Enter.

The IP address must be in the range 1.0.0.1 - 223.255.255.254 excluding 127.x.x.x.

```
Configuring IPV6 Trap for NAT:

Please enter the NAT Trap IP Address
2001:db8:85a3::8a2e:130:0:2
```

9. Type the port number of the NAT trap interface and press Enter.

```
Please enter the NAT Trap Port Number
7076
```

- If you do not want to configure NAT, type N and press Enter.

If you are configuring a standalone node, you are prompted to configure the NTP server. Go to Step ["10.d" on page 107](#).

If you are configuring a node to be added to an existing cluster, the Settings Summary is displayed, as shown in the following example:

```
Settings Summary

> IPv4 Change: eth0 is 192.168.26.151 / 255.255.254.0
> Default IPv4 Gateway = 192.168.27.10 on eth0
> IPV6 Change: eth0 is 2001:db8:30:0:0:26:0:97 / 120
> Default IPv6 Gateway = 2001:db8:30:0:0:26:0:95 on eth0
> IPv4 DNS add: 192.168.27.2
```



```

> DNS add: 2001:db8:30:0:0:26:0:97
> IPv4 Change: eth3 is 192.168.130.2 / 255.255.254.0
> eth3 IPv4 Gateway: 192.168.130.5
> IPV6 Change: eth3 is 2001:db8:35:0:0:130:0:97 / 120
> eth3 IPv6 Gateway: 2001:db8:35:0:0:130:0:95
> NAT IPv4 Outbound SSH IP: 192.168.26.213
> NAT IPv4 Outbound SSH Port: 5051
> NAT IPv6 Outbound SSH IP: 2001:db8:85a3::8a2e:130:0:2
> NAT IPv6 Outbound SSH Port: 5053
> Node to be added to existing cluster

```

```

A> Apply settings
C> Change settings
Q> Quit and set up later
R> Redraw Menu

```

Choice [ACQR]:

- To apply the settings, type **A**.

The settings that you configured are applied and a series of messages is displayed on the console, and then the Junos Space Settings Menu is displayed as shown in the following example:

```

Junos Space Settings Menu

1> Change Password
2> Change Network Settings
3> Change Time Options
4> Retrieve Logs
5> Security
6> (Debug) run shell

A> Apply Settings
Q> Quit
R> Redraw Menu

Choice [1-6,QR]:

```

- To change the settings, type **C**.

You are prompted to reenter all the basic configuration information that you have configured up to this point.

- To quit the configuration without applying the settings, type **Q**.

The Junos Space Settings Menu is displayed.



**CAUTION:** If you quit the configuration without applying the settings, then all the settings are discarded.

## Configuring the eth1 Interface

From Junos Space Network Management Platform Release 14.1R1 onward, you can configure the eth1 Ethernet interface as an administrative interface. Configure the eth1 interface when the Junos Space node reboots after the basic configuration is complete.

### NOTE:

- The eth1 interface must be configured separately for each node in a multinode fabric.
- If you configure the eth1 interface, SSH is disabled on the eth0 and the eth3 interfaces. You can then access the CLI of the Junos Space appliance only through the eth1 interface.

To configure the eth1 interface:

1. On the Junos Space Settings Menu, type **6** to access the shell.  
You are prompted to enter your password.
2. Type your password and press Enter.  
The shell prompt appears.
3. At the shell prompt, type `jmp_config` and press Enter.  
You are prompted to enter the IP address of the eth1 interface.
4. Type the IP address of the eth1 interface in dotted decimal notation and press Enter.  
The IP address can be in the same subnet as the virtual IP (VIP) address or in a different subnet. If the IP address is not in the same subnet as the VIP address, you are prompted to enter the subnet mask and then the default gateway for the eth1 interface.
5. (Optional) Type the subnet mask for the eth1 interface in dotted decimal notation and press Enter.
6. (Optional) Type the default gateway in dotted decimal notation and press Enter.  
The eth1 interface is configured.
7. To verify that the eth1 address is configured, run the `ifconfig eth1` command and check that the IP address displayed for eth1 is the same as the one that you configured.

You can now access the Junos Space node through the eth1 interface to perform administrative tasks.

To troubleshoot issues in configuring the eth1 interface, refer to the `/var/log/changeEth1.log` file.

## RELATED DOCUMENTATION

[Junos Space Ethernet Interfaces Overview | 4](#)

[Changing Network and System Settings for a Junos Space Appliance | 151](#)

[Configuring a Junos Space Appliance as a Standalone or Primary FMPM Node | 123](#)

[Installing a Junos Space Image on a Junos Space Appliance by Using a USB Drive | 142](#)

## Configuring a Junos Space Appliance as a Standalone or Primary FMPM Node

### IN THIS SECTION

- [Configuring a Junos Space Appliance as the Primary FMPM Node | 125](#)
- [Configuring the eth1 Interface | 133](#)

You can configure a Junos Space Appliance as a Junos Space node or as a specialized network monitoring node used for fault monitoring and performance monitoring (FMPM). An FMPM node can be configured as a standalone or primary FMPM node, or as a secondary or backup FMPM node. The first FMPM node that you configure is always the standalone or primary node; this node performs fault and performance monitoring of the devices and nodes, and any events or alarms are stored in a PostgreSQL database on this node. This topic explains how you can configure an appliance as a primary FMPM node.

**NOTE:** You must have at least one appliance already configured as a Junos Space node to configure a different appliance as an FMPM node.

To configure a Junos Space Appliance as a standalone or primary FMPM node, you must configure basic network and system settings to make the appliance accessible on the network.

**NOTE:**

- From Junos Space Network Management Platform Release 14.1R2 onward, you can configure Junos Space Ethernet interfaces with only IPv4 addresses, or both IPv4 and IPv6 addresses.
- From Junos Space Network Management Platform Release 16.1R1 onward, you can configure access to Junos Space through a Network Address Translation (NAT) gateway.

Before you begin, do the following:

- Ensure that the Junos Space Appliance is connected to a management console and that the management device is powered on.
- Ensure that the appliance is booted and displays the login prompt at the console.
- Ensure that 100 GB free disk space is available before configuring a node as an FMPM node.
- Ensure that you have the following information available:
  - IPv4 address and subnet mask for the eth0 Ethernet interface
  - (Optional) IPv6 address and prefix for the eth0 Ethernet interface
  - IPv4 address of the default gateway
  - (Optional) IPv6 address of the default gateway
  - IPv4 address of the name server
  - (Optional) IPv6 address of the name server
  - Virtual IP (VIP) address of the FMPM nodes in IPv4 and IPv6 formats

The VIP address is used for communications between Junos Space nodes and FMPM nodes. This IP address must be in the same subnet as the IP address assigned to the eth0 Ethernet interface, and the VIP address must be different from the VIP address used to access the Web GUI.

- IPv4 address or URI of NTP source to synchronize time
- (Optional) IPv4 address for the NAT trap
- (Optional) IPv6 address for the NAT trap
- (Optional) IPv4 port number for the NAT trap
- (Optional) IPv6 port number for the NAT trap

This topic discusses the following tasks:

## Configuring a Junos Space Appliance as the Primary FMPM Node

You can configure a Junos Space Appliance as an FMPM node.

To configure the appliance as a standalone or primary FMPM node:

1. At the serial console login prompt, type the default username (`admin`) and press Enter.
2. Type the default password (`abc123`) and press Enter.  
You are prompted to change your password.
3. To change the default password, do the following:
  - a. Type the default password and press Enter.
  - b. Type your new password and press Enter.
  - c. Retype your new password and press Enter.

If the password has is changed successfully, the message `passwd: all authentication tokens updated successfully` is displayed.

### NOTE:

- All passwords are case-sensitive.
- You can choose a password that is at least eight characters long, and that contains characters from at least three of the following four character classes: uppercase letters, lowercase letters, numbers (0 through 9), and special characters.

However, if a password satisfies the preceding criteria but contains only a single uppercase letter at the beginning or only a single number at the end, then that password is considered invalid. In order to be counted as a valid character class, a single uppercase letter must not be at the beginning of the password, and a single number must not be at the end. For example, `Abcdwip9`, `Qc9rdiwt`, and `bRfjvin9` are invalid passwords, but `AAbcdwip99`, `Qc9rdiwtQ`, and `bRfjvin99` are valid passwords.

- Alternatively, instead of using a string of characters, you can choose a passphrase that is between 16 and 40 characters long, and contains at least three dictionary words separated by at least one special character. For example, `big#three;fork` (14 characters long) and `circlefaceglass` (no special characters) are invalid passphrases, but `@big#three;fork&` and `circle;face;glass` are valid passphrases.

4. Type the new password to log in to the appliance and press Enter.
5. Type `F` to proceed with the configuration of the appliance as an FMPM node.

6. Configure the IP address of the eth0 Ethernet interface.

This IP address will be used as the IP address of the FMPM node.

```
Configuring Eth0 :

1> Configure IPv4
2> Configure Both IPv4 and IPv6

R> Redraw Menu

Choice [1-2,R]:
```

- To configure the IPv4 address of the eth0 interface:
  - a. Type 1.
  - b. Type the IPv4 address for the eth0 interface in dotted-decimal notation and press Enter.

```
Please enter new IPv4 address for interface eth0:
192.0.2.25
```

**NOTE:** All nodes that you configure in a cluster (fabric) must be in the same subnet.

- c. Type the new subnet mask for the IPv4 address and press Enter.

```
Please enter new IPv4 subnet mask for interface eth0:
255.255.0.0
```

- d. Type the IP address of the default gateway for the eth0 Ethernet interface in dotted-decimal notation and press Enter.

```
Enter the default IPv4 gateway as a dotted-decimal IP address:
192.0.2.155
```

- To configure both IPv4 and IPv6 addresses:
  - a. Type 2.

- b. Type the IPv4 address for the eth0 interface in dotted-decimal notation and press Enter.

```
Please enter new IPv4 address for interface eth0
192.0.2.25
```

- c. Type a subnet mask for the eth0 interface in dotted-decimal notation and press Enter.

```
Please enter new IPv4 subnet mask for interface eth0:
255.255.0.0
```

- d. Type the IPv4 address of the default gateway for the eth0 interface in dotted-decimal notation and press Enter.

```
Enter the default IPv4 gateway as a dotted-decimal IP address:
192.0.2.155
```

- e. Type the IPv6 address and prefix for the eth0 interface and press Enter.

```
Please enter new IPv6 address with prefix (IPv6 Address/prefix) for interface eth0:
2001:db8:10:1:192:10:2:50/64
```

- f. Type the IPv6 address of the default gateway for the eth0 interface and press Enter.

```
Enter the IPv6 gateway:
2001:db8:0:1:192:0:2:155
```

7. Type the IPv4 address of the name server and press Enter.

```
Please type the IPv4 nameserver address in dotted decimal notation:
192.0.2.15
```

8. Type the IPv6 address of the name server and press Enter.

```
Please type the IPv6 nameserver address:
2001:db8:0:1:192:10:2:10
```

9. Type **P** when prompted Choose the role for this FMPM specialized node [P/B].

The FMPM node can be configured as follows:

- (P)rimary - Standalone or first FMPM node in an FMPM high availability pair
- (B)ackup - Backup FMPM node in an FMPM high availability pair

Choosing P installs the node as a standalone FMPM node or the primary node in an FMPM HA setup. This node performs fault and performance monitoring of the devices and nodes, and any events or alarms is stored in a PostgreSQL database on this node.

**10.** Configure the IP address for the FMPM service.

This IP address is the VIP address of the FMPM nodes and is used for communication between the Junos Space nodes and the FMPM nodes.

**NOTE:** The FMPM service IP address and the FMPM node IP address should be in the same subnet.

Configuring IP address for FMPM service:

```
1> Configure Both IPv4 and IPv6
```

```
R> Redraw Menu
```

```
Choice [1,R]:
```

**NOTE:** If you configure only an IPv4 address for the eth0 interface, you are provided with an option to configure only the IPv4 address for the FMPM service.

- Type **1** to configure the IPv4 and IPv6 addresses for the FMPM service.
- Type the IPv4 address for the FMPM service and press Enter.

Please enter IPv4 address for FMPM service:

```
192.0.2.75
```



- c. Type the IPv6 address for the FMPM service and press Enter.

```
Please enter new IPv6 address for FMPM service
2001:db8:0:1:192:10:3:50
```

You are prompted to specify whether you want to configure NAT.

- 11.** Specify whether you want to configure access to Junos Space using NAT.

```
Do you want to enable NAT service ? [Y/N]
```

- To configure NAT, type **Y**.

**NOTE:** If you choose to configure NAT, the options that are displayed depend on the IP address or addresses that you have configured for the eth0 interface. If the eth0 interface is assigned an IPv4 address, you are prompted to enter the IPv4 address for the NAT trap interface. If the eth0 interface is assigned an IPv4 address and an IPv6 address, you are prompted to configure either an IPv4 address, an IPv6 address, or both IPv4 and IPv6 addresses for the NAT trap interface.

You are prompted to configure NAT IP addresses.

```
1> Configure IPv4
2> Configure IPv6
3> Configure IPv4 and IPv6

R> Redraw Menu
Choice [1-2, R]:
```

- To configure the IPv4 address:
  - a. Type **1** and press Enter.
  - b. Type the IPv4 address of the NAT trap interface and press Enter.

The IP address must be in the range 1.0.0.1 - 223.255.255.254 excluding 127.x.x.x.

```
Configuring IPV4 Trap for NAT:
```

```
Please enter the NAT Trap IP Address
192.168.27.1
```

- c. Type the port number of the NAT trap interface and press Enter.

The port number must be in the range 0-65535.

```
Please enter the NAT Trap Port Number
4584
```

- To configure the IPv6 address:
  - a. Type **2** and press Enter.
  - b. Type the IPv6 address of the NAT trap interface and press Enter.

```
Configuring IPV6 Trap for NAT:

Please enter the NAT Trap IP Address
2001:db8:85a3::8a2e:130:0:5
```

- c. Type the port number of the NAT trap interface and press Enter.

The port number must be in the range 0-65535.

```
Please enter the NAT Trap Port Number
5055
```

- To configure IPv4 and IPv6:
  - a. Type **3** and press Enter.
  - b. Type the IPv4 address of the NAT trap interface and press Enter.

The IP address must be in the range 1.0.0.1 - 223.255.255.254 excluding 127.x.x.x.

```
Configuring IPV4 Trap for NAT:

Please enter the NAT Trap IP Address
192.168.27.1
```

- c. Type the port number of the NAT trap interface and press Enter.

The port number must be in the range 0-65535.

```
Please enter the NAT Trap Port Number
4584
```

- d. Type the IPv6 address of the NAT trap interface and press Enter.

```
Configuring IPV6 Trap for NAT:

Please enter the NAT Trap IP Address
2001:db8:85a3::8a2e:130:0:5
```

- e. Type the port number of the NAT trap interface and press Enter.

The port number must be in the range 0-65535.

```
Please enter the NAT Trap Port Number
5055
```

- If you do not want to configure NAT, type **N** and press Enter.

You are prompted to specify whether you want to add an NTP server.

12. You must add an NTP server or specify the current time for the node. Do one of the following:

- To add an NTP server, type **y**, enter the hostname of the NTP server when prompted, and press Enter.
- To specify the current time (UTC), type **n**, enter the time, and press Enter.

The settings summary is displayed, as shown in the following example:

```
Settings Summary:

> IPv4 Change: eth0 is 192.168.26.151 / 255.255.254.0
> Default IPv4 Gateway = 192.168.27.10 on eth0
> IPv6 Change: eth0 is 2001:db8:85a3:0:0:8a2e:c0a9:1b37 / 64
> Default IPv6 Gateway = 2001:db8:85a3:0:0:8a2e:c0a9:1bbd on eth0
> IPv4 DNS add: 192.168.27.2
```

```

> DNS add: 2001:db8:85a3:0:0:8a2e:c0a9:1bbd
> Create as first node or standalone
> FMPM service IPv4 address is 192.68.26.153
> Web IPv6 address is 2001:db8:85a3:0:0:8a2e:c0a9:1b38/64
> NTP add: device1.example.com
> NAT IPv4 Trap IP: 192.168.26.213
> NAT IPv4 Trap Port: 5056
> NAT IPv6 Trap IP: 2001:db8:85a3::8a2e:130:0:5
> NAT IPv6 Trap Port: 5058
> Node display name will be set when it is added.
> This node will be the primary FMPM specialized node.

A> Apply settings
C> Change settings
Q> Quit and set up later
R> Redraw Menu

Choice [ACQR]:

```

**13.** Review the settings that you configured.

**14.** You can change the settings, quit without applying the settings, or apply the settings. Do one of the following:

- To apply the settings, type A. The settings that you configured are applied and a series of messages is displayed on the console, and then the Junos Space Settings Menu is displayed, as follows:

```

Junos Space Settings Menu

1> Change Password
2> Change Network Settings
3> Change Time Options
4> Retrieve Logs
5> Security
6> (Debug) run shell

Q> Quit
R> Redraw Menu

Choice [1-6,QR]:

```

- To change the settings, type C, and follow the prompts on the CLI.

- To quit the configuration without applying the settings, type Q.



**CAUTION:** If you quit the configuration without applying the settings, then all the settings are discarded.

15. (Optional) If you have applied the settings, then type Q to quit.

You are taken to the console login prompt.

The configuration of the appliance as a standalone or primary FMPM node is now complete.

**NOTE:** After you configure an FMPM node, you must add it to the Junos Space fabric using the Junos Space Network Management Platform. For more information, see the *Adding a Node to an Existing Junos Space Fabric* topic in the *Junos Space Network Management Platform Workspaces Feature Guide* (available at [http://www.juniper.net/techpubs/en\\_US/release-independent/junos-space/index.html](http://www.juniper.net/techpubs/en_US/release-independent/junos-space/index.html)).

You can specify the name of the FMPM node when you add the node to the Junos Space fabric.

## Configuring the eth1 Interface

From Junos Space Network Management Platform Release 14.1R1 onward, you can configure the eth1 Ethernet interface as an administrative interface. For the FMPM node, configure the eth1 interface when the node reboots after the basic configuration is complete.

### NOTE:

- The eth1 interface must be configured separately for each node in a multinode fabric.
- If you configure the eth1 interface, SSH is disabled on the eth0 interface. You can then access the CLI of the Junos Space appliance only through the eth1 interface.

To configure the eth1 interface:

1. On the Junos Space Settings Menu, type **6** to access the shell.  
You are prompted to enter your password.
2. Type your password and press Enter.  
The shell prompt appears.
3. At the shell prompt, type `jmp_config` and press Enter.  
You are prompted to enter the IP address of the eth1 interface.
4. Type the IP address of the eth1 interface in dotted decimal notation and press Enter.

The IP address can be in the same subnet as the virtual IP (VIP) address or in a different subnet. If the IP address is not in the same subnet as the VIP address, you are prompted to enter the subnet mask and then the default gateway for the eth1 interface.

5. (Optional) Type the subnet mask for the eth1 interface in dotted decimal notation and press Enter.
6. (Optional) Type the default gateway in dotted decimal notation and press Enter.

The eth1 interface is configured.

7. To verify that the eth1 address is configured, run the `ifconfig eth1` command and check that the IP address displayed for eth1 is the same as the one that you configured.

You can now access the FMPM node through the eth1 interface to perform administrative tasks.

To troubleshoot issues in configuring the eth1 interface, refer to the `/var/log/changeEth1.log` file.

## RELATED DOCUMENTATION

[Junos Space Ethernet Interfaces Overview | 4](#)

[Configuring a Junos Space Appliance as a Backup or Secondary FMPM Node for High Availability | 134](#)

[Changing Network and System Settings for a Junos Space Appliance | 151](#)

[Configuring a Junos Space Appliance as a Junos Space Node | 97](#)

[Installing a Junos Space Image on a Junos Space Appliance by Using a USB Drive | 142](#)

## Configuring a Junos Space Appliance as a Backup or Secondary FMPM Node for High Availability

### IN THIS SECTION

- [Configuring a Junos Space Appliance as the Secondary FMPM Node | 136](#)
- [Configuring the eth1 Interface | 141](#)

You can configure a Junos Space Appliance as a Junos Space node or as a specialized network monitoring node used for fault monitoring and performance monitoring (FMPM).

An FMPM node can be configured as a standalone or primary FMPM node, or as a secondary or backup FMPM node. The first FMPM node that you configure is always the standalone or primary node; this

node performs fault and performance monitoring of the devices and nodes, and any events or alarms are stored in a PostgreSQL database on this node. The second FMPM node that you configure is the backup or secondary FMPM node. The PostgreSQL database containing the fault and performance monitoring data is replicated from the primary FMPM node to the secondary FMPM node. When the primary node is down or being rebooted, the secondary node automatically assumes charge.

A primary and a secondary FMPM node are referred to as a cluster or a team; therefore, an FMPM team can consist of a maximum of two nodes.

**NOTE:** You must have at least one appliance already configured as a Junos Space node, and an appliance configured as a primary FMPM node, before you configure a different appliance as a secondary FMPM node.

To configure a Junos Space Appliance as a backup or secondary FMPM node, you must configure basic network and system settings to make the appliance accessible on the network.

**NOTE:** From Junos Space Network Management Platform Release 14.1R2 onward, you can configure Junos Space Ethernet interfaces with only IPv4 addresses, or both IPv4 and IPv6 addresses.

Before you begin, do the following:

- Ensure that the Junos Space Appliance is connected to a management console and that the management device is powered on.
- Ensure that the appliance is booted and displays the login prompt at the console.
- Ensure that 100 GB free disk space is available before configuring a node as an FMPM node.
- Ensure that you have the following information available:
  - IPv4 address and subnet mask for the eth0 Ethernet interface
  - (Optional) IPv6 address and prefix for the eth0 Ethernet interface
  - IPv4 address of the default gateway
  - (Optional) IPv6 address of the default gateway
  - IPv4 address of the name server
  - (Optional) IPv6 address of the name server
  - Virtual IP (VIP) address of the FMPM nodes in IPv4 and IPv6 formats

The VIP address is used for communications between Junos Space nodes and FMPM nodes. This IP address must be in the same subnet as the IP address assigned to the eth0 Ethernet interface, and the VIP address must be different from the VIP address used to access the Web GUI.

- (Optional) IPv4 address of the eth1 Ethernet interface

If the IP address of the eth1 interface is not in the same subnet as the VIP address, ensure that you have the subnet mask and the default gateway for the eth1 interface.

This topic discusses the following tasks:

## Configuring a Junos Space Appliance as the Secondary FMPM Node

You can configure the Junos Space Appliance as the backup or secondary FMPM node.

To configure an appliance as a backup or secondary FMPM node:

1. At the serial console login prompt, type the default username (`admin`) and press Enter.
2. Type the default password (`abc123`) and press Enter.  
You are prompted to change your password.
3. To change the default password, do the following:
  - a. Type the default password and press Enter.
  - b. Type your new password and press Enter.
  - c. Retype your new password and press Enter.

If the password is changed successfully, the message `passwd: all authentication tokens updated successfully` is displayed.

### NOTE:

- All passwords are case-sensitive.
- You can choose a password that is at least eight characters long, and that contains characters from at least three of the following four character classes: uppercase letters, lowercase letters, numbers (0 through 9), and special characters.

However, if a password satisfies the preceding criteria but contains only a single uppercase letter at the beginning or only a single number at the end, then that password is considered invalid. In order to be counted as a valid character class, a single uppercase letter must not be at the beginning of the password, and a single number must not be at



the end. For example, Abcdwip9, Qc9rdiwt, and bRfjvin9 are invalid passwords, but AAbcdwip99, Qc9rdiwtQ, and bRfjvin99 are valid passwords.

- Alternatively, instead of using a string of characters, you can choose a passphrase that is between 16 and 40 characters long, and contains at least three dictionary words separated by at least one special character. For example, big#three;fork (14 characters long) and circlefaceglass (no special characters) are invalid passphrases, but @big#three;fork& and circle;face;glass are valid passphrases.

4. Type the new password to log in to the appliance and press Enter.
5. Type F to proceed with the configuration of the appliance as an FMPM node.
6. Configure the IP address of the eth0 Ethernet interface.

This IP address is used as the IP address of the FMPM node.

Configuring Eth0 :

1> Configure IPv4

2> Configure Both IPv4 and IPv6

R> Redraw Menu

Choice [1-2,R]:

- To configure the IPv4 address of the eth0 interface:
  - a. Type 1.
  - b. Type the IPv4 address for the eth0 interface in dotted-decimal notation and press Enter.

Please enter new IPv4 address for interface eth0:  
192.0.2.51

**NOTE:** All nodes that you configure in a cluster (fabric) must be in the same subnet.

- c. Type the new subnet mask for the IPv4 address and press Enter.

Please enter new IPv4 subnet mask for interface eth0:  
255.255.0.0

- d. Type the IP address of the default gateway for the eth0 Ethernet interface in dotted-decimal notation and press Enter.

```
Enter the default IPv4 gateway as a dotted-decimal IP address:  
192.0.2.155
```

- To configure both IPv4 and IPv6 addresses:

- a. Type 2.

- b. Type the IPv4 address for the eth0 interface in dotted-decimal notation and press Enter.

```
Please enter new IPv4 address for interface eth0  
192.0.2.52
```

- c. Type a subnet mask for the eth0 interface in dotted-decimal notation and press Enter.

```
Please enter new IPv4 subnet mask for interface eth0:  
255.255.0.0
```

- d. Type the IPv4 address of the default gateway for the eth0 interface in dotted-decimal notation and press Enter.

```
Enter the default IPv4 gateway as a dotted-decimal IP address:  
192.0.2.155
```

- e. Type the IPv6 address and prefix for the eth0 interface and press Enter.

```
Please enter new IPv6 address with prefix (IPv6 Address/prefix) for interface eth0:  
2001:db8:0:1:192:0:2:51/64
```

- f. Type the IPv6 address of the default gateway for the eth0 interface and press Enter.

```
Enter the IPv6 gateway:  
2001:db8:0:1:192:0:2:155
```

7. Type the IPv4 address of the name server and press Enter.

```
Please type the IPv4 nameserver address in dotted decimal notation:
192.0.2.15
```

8. Type the IPv6 address of the name server and press Enter.

```
Please type the IPv6 nameserver address:
2001:db8:0:1:192:0:2:15
```

9. Type B to configure the node as the backup or secondary FMPM node.

The settings summary is displayed as follows:

```
1> IP Change: eth0 is 10.205.56.136 / 255.255.0.0
2> Default Gateway = 10.205.255.254 on eth0
3> DNS add: 10.209.194.14
4> This node will be the backup FMPM specialized node.

1> IPv4 Change: eth0 is 192.0.2.51 / 255.255.0.0
2> Default IPv4 Gateway = 192.0.2.155 on eth0
3> IPV6 Change: eth0 is 2001:db8:0:1:192:0:2:51 / 64
4> Default IPv6 Gateway = 2001:db8:0:1:192:0:2:155 on eth0
5> IPv4 DNS add: 192.0.2.15
6> DNS add: 2001:db8:0:1:192:0:2:15
8> This node will be the backup FMPM specialized node.

A> Apply settings
C> Change settings
Q> Quit and set up later
R> Redraw Menu

Choice [ACQR]:
```

10. Review the settings that you configured.
11. You can change the settings, quit without applying the settings, or apply the settings. Do one of the following:

- To apply the settings, type A. The settings that you configured are applied and a series of messages is displayed on the console, and then the Junos Space Settings Menu is displayed, as follows:

```

Junos Space Settings Menu

1> Change Password
2> Change Network Settings
3> Change Time Options
4> Retrieve Logs
5> Security
6> (Debug) run shell

Q> Quit
R> Redraw Menu

Choice [1-6,QR]:

```

- To change the settings, type C, and follow the prompts on the CLI.
- To quit the configuration without applying the settings, type Q.



**CAUTION:** If you quit the configuration without applying the settings, then all the settings are discarded.

**12.** (Optional) If you have applied the settings, then type Q to quit.

You are taken to the console login prompt.

The configuration of the appliance as a backup or secondary FMPM node is now complete.

**NOTE:** After you configure an FMPM node, you must add it to the Junos Space fabric using the Junos Space Network Management Platform. For more information, see the *Adding a Node to an Existing Junos Space Fabric* topic in the *Junos Space Network Management Platform Workspaces Feature Guide* (available at [http://www.juniper.net/techpubs/en\\_US/release-independent/junos-space/index.html](http://www.juniper.net/techpubs/en_US/release-independent/junos-space/index.html)).

You can specify the name of the FMPM node when you add the node to the Junos Space fabric.

## Configuring the eth1 Interface

From Junos Space Network Management Platform Release 14.1R1 onward, you can configure the eth1 Ethernet interface as an administrative interface. For the FMPM node, configure the eth1 interface when the node reboots after the basic configuration is complete.

### NOTE:

- The eth1 interface must be configured separately for each node in a multinode fabric.
- If you configure the eth1 interface, SSH is disabled on the eth0 interface. You can access the CLI of the Junos Space appliance only through the eth1 interface.

To configure the eth1 interface:

1. On the Junos Space Settings Menu, type **6** to access the shell.  
You are prompted to enter your password.
2. Type your password and press Enter.  
The shell prompt appears.
3. At the shell prompt, type `jmp_config` and press Enter.  
You are prompted to enter the IP address of the eth1 interface.
4. Type the IP address of the eth1 interface in dotted decimal notation and press Enter.  
The IP address can be in the same subnet as the virtual IP (VIP) address or in a different subnet. If the IP address is not in the same subnet as the VIP address, you are prompted to enter the subnet mask and then the default gateway for the eth1 interface.
5. (Optional) Type the subnet mask for the eth1 interface in dotted decimal notation and press Enter.
6. (Optional) Type the default gateway in dotted decimal notation and press Enter.  
The eth1 interface is configured.
7. To verify that the eth1 address is configured, run the `ifconfig eth1` command and check that the IP address displayed for eth1 is the same as the one that you configured.  
You can now access the FMPM node through the eth1 interface to perform administrative tasks.

To troubleshoot issues in configuring the eth1 interface, refer to the `/var/log/changeEth1.log` file.

## RELATED DOCUMENTATION

[Junos Space Ethernet Interfaces Overview | 4](#)

[Configuring a Junos Space Appliance as a Standalone or Primary FMPM Node | 123](#)

[Changing Network and System Settings for a Junos Space Appliance | 151](#)

## Installing a Junos Space Image on a Junos Space Appliance by Using a USB Drive

Before you begin, ensure that:

- You have a laptop or PC (running Windows or Linux) that is connected to the Internet.
- If you are using a Windows laptop or PC, you must install the Win32 Disk Imager software on your computer to enable the software image to be written on the USB drive. You can download this software for free from <https://sourceforge.net/projects/win32diskimager/>.
- You have a USB drive with at least 4 GB of free space for Junos Space Platform Release 11.4 or later.
- You can connect to the appliance by using the management console.
- You have configured a console terminal or terminal emulation utility to use the following serial connection parameters:
  - Baud rate: 9600 bits per second
  - Data: 8 bits
  - Flow control: None
  - Parity: None
  - Stop bits: 1

**NOTE:** The console terminal or terminal emulation utility maps every key on the keyboard to a code that it then sends through the management console. In some cases, the Delete key on a PC keyboard does not send a DEL or Control-? character. You must ensure that the terminal utility that you are using to connect to the appliance maps a key to the DEL or Control-? character. Typically, this is accomplished by configuring the terminal utility to send a DEL or Control-? character when the Backspace key on the keyboard is pressed.

**NOTE:**

- A Junos Space Appliance is shipped with a version of Junos Space Network Management Platform already installed on it.
- You can install only Junos Space Network Management Platform Release 13.3 (or later) on the JA2500 Junos Space Appliance.
- For information about how to upgrade Junos Space Network Management Platform, refer to the *Upgrading Junos Space Software Overview* and *Upgrading Junos Space Network Management Platform* topics in the *Junos Space Network Management Platform Workspaces Feature Guide* (available at [https://www.juniper.net/documentation/en\\_US/release-independent/junos-space/index.html](https://www.juniper.net/documentation/en_US/release-independent/junos-space/index.html)).
- For information about upgrading to Junos Space Network Management Platform Release 16.1R1, see [Upgrading to Junos Space Network Management Platform Release 16.1R1](#).

You can install a Junos Space Network Management Platform software image on an appliance by using a standard USB drive; both USB 2.0 and USB 3.0 are supported. You can use this procedure to restore the factory settings on an appliance or if you want to install a different version of the software.

This installation procedure has three main steps:

1. Creating a bootable USB drive
2. Ensuring that the appliance's BIOS boots from the USB drive instead of the appliance's hard disk
3. Installing the software image on the appliance

To install a software image on a Junos Space Appliance by using a USB drive:

1. Plug the USB drive into the USB port of a laptop or PC that is connected to the Internet.
2. Using a Web browser, navigate to the Juniper Networks software download site (<https://www.juniper.net/support/downloads/>), then click **Junos Space Network Management Platform**.
3. On the subsequent page, click the **Software** tab and then click **Image for hardware Appliance** to download the Junos Space software image.

For Junos Space Platform Release 16.1R1 and later, the filename of the downloaded image is in the **space-*version*.*spin-number*-usb.iso** format, where *version* refers to the major version number and *spin-number* refers to the spin number within that release; for example, **space-16.1R1.1-usb.iso**.

**NOTE:** For Junos Space Platform versions earlier than Release 16.1, the filename of the downloaded image is in the **space-*version*.*spin-number*.img** format, where *version* refers to

the major version number and *spin-number* refers to the spin number within that release; for example, **space-15.1R1.1.img**.



**CAUTION:** Do not modify the filename of the software image that you download from the Juniper Networks support site. If you modify the filename, the installation fails.

**NOTE:** By default, the image for the latest version of the software is displayed on this page. To download previous versions of the software, select a release number from the **Release** list.

4. Create a bootable USB drive by using one of the following procedures:

**NOTE:**

- If the USB drive has files that you would like to keep, save the files to your PC or laptop *before* you begin this procedure.
  - The bootable USB drive that you create using these procedures will not be usable as a normal USB drive. If you want to use the USB drive for storing files, you must reformat the drive.
- 
- If you are using a computer with Windows as the operating system:
    - a. Open the Win32 Disk Imager software, which was installed on your computer.
    - b. In the Win32 Disk Imager window, click the Open or Browse icon, and in the subsequent dialog box, select the image file that you want to copy to the USB drive.
    - c. In the Win32 Disk Imager window, verify that the drive letter displayed in the **Device** drop-down box matches the chosen USB drive. If a different drive letter is displayed, select the drive letter that matches the USB device from the **Device** list.
    - d. Click **Write**, and in the confirmation dialog box that appears, click **Yes**.

A progress bar in the Win32 Disk Image window displays the status; if the write operation is successful, a message is displayed.
    - e. Click **Exit** to exit the Win32 Disk Imager window.
    - f. Eject the USB drive and unplug it from the computer.



- If you are using a computer with Mac OS as the operating system:
  - a. Open a shell (CLI).
  - b. Use the `cd` command to go to the directory containing the software image file.
  - c. Run the `diskutil list` command to determine the disk to which the USB is assigned.

```
[user@host ~]$ diskutil list
```

- d. Run `diskutil unmountDisk /dev/diskN` to unmount the disk.

```
[user@host ~] diskutil unmountDisk /dev/diskN
```

where `/dev/diskN` is the disk to which the USB is assigned.

- e. For Junos Space Platform Release 16.1R1 and later, type the following command and press Enter:

```
[user@host ~]$ sudo dd if=space-version.spinnumber-usb.iso of=/dev/usb-drive
```

where `space-version.spin-number-usb.iso` is the name of the downloaded Junos Space image file, and `/dev/usb-drive` is the name of the device drive to which your USB drive is mapped.

**NOTE:** For releases prior to Junos Space Platform Release 16.1R1, type the following command to copy the image file to the USB drive and press Enter.

```
[user@host ~]$ sudo dd if=space-version.spinnumber.img of=/dev/usb-drive
```

where `space-version.spin-number.img` is the name of the downloaded Junos Space image file, and `/dev/usb-drive` is the name of the device drive to which your USB drive is mapped.

The image file is copied to the USB drive and you are taken to the command prompt.

- f. Unplug the USB drive from the computer.
- If you are using a computer with Linux as the operating system:

**NOTE:** Although you can use any of the available tools, we recommend that you use the `dd` command in Linux to create a bootable USB drive.

- a. Open a shell (CLI).
- b. Use the `cd` command to go to the directory containing the software image file.
- c. Run the `fdisk -l` command to determine the disk to which the USB is assigned; for example, *disk/sdb*.

```
[user@host ~]$ disk -l
```

- d. For Junos Space Platform Release 16.1R1, type the following command and press Enter:

```
[user@host ~]$ dd if=space-version.spinnumber-usb.iso of=/dev/sdb
```

where *space-version.spin-number-usb.iso* is the name of the downloaded Junos Space image file, and */dev/sdb* is the name of the device drive to which your USB drive is mapped.

**NOTE:** For releases prior to Junos Space Platform Release 16.1R1, type the following command to copy the image file to the USB drive and press Enter.

```
[user@host ~]$ dd if=space-version.spinnumber.img of=/dev/sdb
```

where *space-version.spin-number.img* is the name of the downloaded Junos Space image file, and */dev/sdb* is the name of the device drive to which your USB drive is mapped.

The image file is copied to the USB drive and you are taken to the command prompt.

- e. Eject and unplug the USB drive from the computer.
5. Plug the USB drive into the USB port of the Junos Space Appliance on which you want to install the software image.

**NOTE:** To install the software image from the USB drive, the boot priority order in the appliance must have USB boot at the top. By default, the appliance first attempts to boot from the USB drive first and then from the RAID volume or hard drive. However, if you have

changed the boot order in the BIOS of the appliance, you must access the boot menu and change the boot order. You do this by sending the DEL or Control-? character three times as soon as you power on the appliance.

6. To access the appliance boot menu:
  - a. Power on the appliance.
  - b. As soon as the appliance starts powering on, press the key that you have mapped to send the DEL character in the terminal emulation utility. In most cases, this would be the Backspace key.

**NOTE:** If the hard disk LEDs begin to flash at this point for more than a few seconds, the appliance is booting from the hard disk instead of the USB drive, and the BIOS menu will not be loaded. In this case, you need to power down the appliance and repeat this step.

If you are successful in accessing the BIOS setup, the boot menu appears after about one minute.

7. Ensure that the USB boot is at the top of the appliance boot priority order. If USB KEY:CBM USB 2.0- (USB 2.0) is not at the top of the list, do the following:
  - a. Use the down arrow to select USB KEY:CBM USB 2.0- (USB 2.0) and use the + key to move the entry to the top of the list.
  - b. Press the F10 key to save your changes and exit the BIOS setup.

The appliance restarts and uses the new boot order, thereby booting from the USB drive. The boot prompt displays a menu, as follows:

- reinstall
- rescue-kvm
- rescue-serial
- local

You can use the up and down arrows to move between the options. Press Enter to make your selection.



**WARNING:** The `reinstall` command explained in the next step overwrites your hard disk drive with a new factory default Junos Space installation and erases the previous installation and configuration. If you do not want to proceed, power off the appliance immediately.

- At the boot prompt, type `reinstall` and press Enter.

**NOTE:** If no input is provided for 30 seconds, the appliance boots from the local disk by default.

The reinstallation process takes approximately 2 hours and 30 minutes. When the installation is complete, the appliance powers down.

- After the appliance has powered down, remove the USB drive from the appliance.

**NOTE:** Because the appliance boot order was changed earlier in this procedure, the appliance will try to boot from the USB drive before choosing the next option. You can change the boot order of the appliance at any time using the method explained previously in this procedure.

- (Optional) Power on the appliance by toggling the power switch located at the rear panel of the appliance.

The appliance boots with the version of the Junos Space Network Management Platform that you installed.

You must configure the basic settings for your appliance before you can use it to manage devices. Refer to "[Configuring a Junos Space Appliance as a Junos Space Node](#)" on page 97 and "[Configuring a Junos Space Appliance as a Standalone or Primary FMPPM Node](#)" on page 123 for details.

## RELATED DOCUMENTATION

[Booting the Junos Space Appliance](#) | 96

[Changing Network and System Settings for a Junos Space Appliance](#) | 151

[Powering Off the Junos Space Appliance](#) | 148

## Powering Off the Junos Space Appliance

### IN THIS SECTION

- [Powering Off Using the Management Console](#) | 149

## ● Powering Off Using the Appliance Power Switch | 150

There are three ways to power off or power down a Junos Space Appliance:

- Using the management console
- Using the appliance power switch
- Using the Junos Space Network Management Platform. Refer to the *Shutting Down or Rebooting Nodes in the Junos Space Fabric* topic in the *Junos Space Network Management Platform Workspaces Feature Guide* (available at [http://www.juniper.net/techpubs/en\\_US/release-independent/junos-space/index.html](http://www.juniper.net/techpubs/en_US/release-independent/junos-space/index.html)) for details.

This topic includes the following sections:

### Powering Off Using the Management Console

Before you begin, do the following:

- Connect the Junos Space Appliance to a management console. Refer to "[Connecting a Junos Space Appliance to a Management Console](#)" on page 94 for more information.
- Configure a console terminal or terminal emulation utility to use the following serial connection parameters:
  - Baud rate: 9600 bits per second
  - Data: 8 bits
  - Flow control: None
  - Parity: None
  - Stop bits: 1
- Ensure that the appliance is booted and the console displays the login prompt.

You can power off the Junos Space Appliance from the Junos Space CLI by using the management console.

To power off the appliance using the management console, do the following:

1. At the console login prompt, log in to the appliance as the admin user.  
The Junos Space Settings Menu appears.
2. Type 6, which is the (Debug) `run shell` option.

You are prompted to enter your password.

3. Type the password for the admin user and press Enter.

You are taken to the shell.

4. To power down the appliance, execute the following command:

```
[root@host ~]# poweroff
```

The appliance displays output messages on the management console and then powers off. When the appliance is powered off, the green Power LED on the front panel of the appliance goes out; in addition, the Power Supply Module LED turns amber.

## Powering Off Using the Appliance Power Switch

To power off the Junos Space Appliance using the appliance power switch, do the following:

1. Locate the appliance power switch on the back panel of the appliance chassis.
2. Press the power switch and release it.

The appliance displays output messages on the management console and then powers off.

**NOTE:** If a Junos Space Appliance hangs or is not responding, then you can *hard* power off the appliance by pressing down the appliance power switch and holding it down for 10 seconds. After the appliance powers off, release the power switch.

When the appliance is powered off, the green Power LED on the front panel of the appliance goes out; in addition, the Power Supply Module LED turns amber.

## RELATED DOCUMENTATION

[General Electrical Safety Guidelines and Warnings | 65](#)

[General Safety Guidelines and Warnings | 39](#)

[Installing and Removing JA2500 Junos Space Appliance Hardware Components | 161](#)

# Changing Network and System Settings

## IN THIS CHAPTER

- [Changing Network and System Settings for a Junos Space Appliance | 151](#)

## Changing Network and System Settings for a Junos Space Appliance

### IN THIS SECTION

- [Changing the Password for the Default User | 153](#)
- [Changing Network Settings | 153](#)
- [Modifying the IP Address of the eth1 Interface | 156](#)
- [Changing the Time Zone and NTP Servers | 157](#)
- [Retrieving and Transferring System Log Files | 157](#)
- [Changing Firewall and SSH Settings | 158](#)
- [Accessing the Shell | 158](#)
- [Applying or Cancelling Changes to Settings | 159](#)

You can use the Junos Space CLI to change the network and system settings for a Junos Space Appliance configured as a Junos Space node or a fault monitoring and performance monitoring (FMPPM) node. You can perform the following tasks using the Junos Space CLI:

- Change the default user (admin) password.
- Change network settings such as DNS, virtual IP (VIP) address, and so on.
- Change the time zone and NTP time server.
- Retrieve and transfer system log files.

- Change SSH and firewall settings.
- Run shell commands.

**NOTE:** An openNMS user does not have permission to modify the Junos Space Settings.

Before you begin:

- Ensure that you have connected a management device (PC or laptop) to the appliance using the management console, and that both the appliance and the management device are powered on. Alternatively, you can connect to the appliance via telnet or SSH if the appliance is accessible via the network.
- Ensure that you have logged in to the appliance using the administrator username (admin) and password.

When you log in to the appliance, the Junos Space Settings Menu appears as follows:

```
Junos Space Settings Menu
```

```
1> Change Password
2> Change Network Settings
3> Change Time Options
4> Retrieve Logs
5> Security
6> (Debug) run shell
```

```
A> Apply changes
Q> Quit
R> Redraw Menu
```

```
Choice [1-6,QR]:
```

**NOTE:** Password changes take effect immediately. Any other changes that you make to the settings do not take effect until you apply the changes. You can apply the changes from the Junos Space Settings Menu or any sub-menu by typing **A** at the prompt. Irrespective of the menu or sub-menu that you are in when you apply changes, *all changes* to the appliance settings are applied.

This topic includes the following sections:



## Changing the Password for the Default User

You can change the password for the default user (admin) for the Junos Space Appliance. To change the password, do the following:

1. On the Junos Space Settings Menu, type 1 at the prompt.
2. Type y when you are prompted to change the password for the admin user.
3. Type the current password and press Enter.

### NOTE:

- All passwords are case-sensitive.
- You can choose a password that is at least eight characters long, and that contains characters from at least three of the following four character classes: uppercase letters, lowercase letters, numbers (0 through 9), and special characters.

However, if a password satisfies the preceding criteria but contains only a single uppercase letter at the beginning or only a single number at the end, then that password is considered invalid. In order to be counted as a valid character class, a single uppercase letter must not be at the beginning of the password, and a single number must not be at the end. For example, Abcdwip9, Qc9rdiwt, and bRfvin9 are invalid passwords, but AAbcdwip99, Qc9rdiwtQ, and bRfvin99 are valid passwords.

- Alternatively, instead of using a string of characters, you can choose a passphrase that is between 16 and 40 characters long, and contains at least three dictionary words separated by at least one special character. For example, big#three;fork (14 characters long) and circlefaceglass (no special characters) are invalid passphrases, but @big#three;fork& and circle;face;glass are valid passphrases.

4. Type the new password and press Enter.
5. Retype the new password and press Enter.

If the password change is successful, a message is displayed and you are taken to the Junos Space Settings Menu.

## Changing Network Settings

You can change the following network settings for your Junos Space Appliance:

- *DNS* servers
- Virtual *IP* address of the Junos Space node or FMPM node, Ethernet interface parameters, and NAT configuration
- Static routes

**NOTE:**

- From Junos Space Network Management Platform Release 14.1R2 onward, you can configure Junos Space Ethernet interfaces with only IPv4 addresses, or both IPv4 and IPv6 addresses.
- On a multinode fabric, we recommend that you modify the network settings by using the Junos Space Network Management Platform GUI.
- From Junos Space Network Management Platform Release 16.1R1 onward, you can configure access to Junos Space through a Network Address Translation (NAT) gateway.

To change the network settings, do the following:

1. On the Junos Space Settings Menu, type 2 at the prompt.  
The Change Network Settings menu is displayed.
2. (Optional) To add or delete DNS servers, type 1 at the prompt on the Change Network Settings menu.  
The DNS name server options menu is displayed. You can do the following:

- Type **1** to add the DNS server by entering the IP address in IPv4 format or type **2** to add the DNS server by entering the IP address in IPv6 format and follow the prompts on the CLI.

After the DNS server is added, a message is displayed indicating that the change has been queued. Changes must be applied before you quit the CLI.

**NOTE:** You can add up to three DNS servers.

- To delete an existing DNS server, type the number corresponding to the DNS server that you want to delete, and follow the prompts on the CLI.
3. (Optional) To change the virtual IP address, Ethernet interface parameters, and NAT configuration, type 2 in the Change Network Settings menu.

**NOTE:** If the node is configured to be part of a Junos Space cluster, but is not yet added to the cluster from the Junos Space Platform UI, you can modify only the NAT configuration. The NAT configuration option is displayed even if NAT settings are not specified during the initial configuration of the node.

You can do the following:

- To modify the virtual IP (VIP) address, type 1 and follow the prompts on the CLI.

**NOTE:** For nodes in a Junos Space fabric, you can modify a VIP address from any node in the fabric.

- To modify the settings of the Ethernet interface eth0, type 2 and follow the prompts on the CLI. You can change the IP address of the node, the subnet mask, and the default gateway.
- To modify the settings of the Ethernet interface eth3, type 3 and follow the prompts on the CLI. You can change the IP address of the node, the subnet mask, and the default gateway.

**NOTE:**

- The Change Device Management Interface option is available only if a device management interface (eth3) was specified during the initial configuration of the appliance.
- When you configure the eth3 interface as the device management interface, the IP addresses of the eth0 and eth3 Ethernet interfaces must be in different subnets.

- To modify the NAT configuration, type 4 or 1, depending on the menu options displayed, and follow the prompts on the CLI.

**NOTE:**

- The NAT configuration must not be modified in combination with the other changes that require a reboot of the node. If the node is rebooted, the NAT configuration is discarded. In such cases, modify the settings that require a reboot, reboot the node and then modify the NAT configuration.
- If you modify only the NAT IPv4 or IPv6 address of a virtual appliance configured to be part of a Junos Space cluster, but yet to be added to the cluster from the Junos Space Platform UI, the last specified IP address overwrites the IP address configured during initial configuration. For example, if the virtual appliance was initially configured with a NAT IPv4 address and while modifying the network settings, you specify an IPv6 address, then the IPv4 address is discarded and the IPv6 address is used for the NAT gateway. If both IPv4 and IPv6 are configured initially, then only the IP address that is modified is updated.

4. (Optional) To add or delete a static route, type 3 at the prompt on the Change Network Settings menu.

On the subsequent menu, you can do the following:

- To add a static route, type 1 and follow the prompts on the CLI.

**NOTE:** We recommend that you ensure that the access to the gateway is available before adding a static route.

- To delete an existing static route, type the number corresponding to the static route that you want to delete, and follow the prompts on the CLI.
5. Type **A** to apply all the changes that you made, or type **M** to return to the Junos Space Settings Menu without applying the changes.

## Modifying the IP Address of the eth1 Interface

You may need to modify the IP address of the eth1 interface of a Junos Space Appliance when you move the Junos Space Appliance from one network to another.

**NOTE:** If you configure the eth1 interface, SSH is disabled on the eth0 and the eth3 interfaces. You can then access the CLI of the Junos Space appliance only through the eth1 interface.

To modify the eth1 interface settings:

1. On the Junos Space Settings Menu, type **6** to access the shell.  
You are prompted to enter your password.
2. Type your password and press Enter.  
The shell prompt appears.
3. At the shell prompt, type `jmp_config` and press Enter.  
You are prompted to enter the IP address of the eth1 interface.
4. Type the IP address of the eth1 interface in dotted decimal notation and press Enter.  
The IP address can be in the same subnet as virtual IP (VIP) address or in a different subnet. If the IP address is not in the same subnet as the VIP address, you are prompted to enter the subnet mask and then the default gateway for the eth1 interface.
5. (Optional) Type the subnet mask for the eth1 interface in dotted decimal notation and press Enter.
6. (Optional) Type the default gateway in dotted decimal notation and press Enter.  
The eth1 interface is configured.
7. To verify the modified IP address of the eth1 interface, run the `ifconfig eth1` command and check that the IP address displayed for eth1 is the same as that you modified.

To troubleshoot issues in configuring the eth1 interface, refer to the `/var/log/changeEth1.log` file.

## Changing the Time Zone and NTP Servers

You can change the time zone, add or delete an NTP server, and enable or disable an NTP server. When you configure each Junos Space Appliance with an NTP server, you ensure that if the first node, which is used to synchronize time for all nodes in the fabric, goes down, all other nodes in the fabric remain synchronized. To ensure this behavior, all nodes in a fabric should be configured with the same external NTP server that you configured for the first appliance.

To change the time zone and NTP servers for your Junos Space Appliance, do the following:

1. On the Junos Space Settings Menu, type 3 at the prompt.

The Change Time Options menu is displayed.

2. (Optional) To change the time zone, type 1 and follow the prompts on the CLI.
3. (Optional) To modify NTP servers, type 2.

You are taken to the NTP options menu. You can do the following:

- Type 1 to disable or enable an NTP server, depending on whether the NTP server is enabled or disabled, and follow the prompts on the CLI.
- Type 2 to add an NTP server, and follow the prompts on the CLI.
- Type 3 to delete an NTP server, and follow the prompts on the CLI.

The option to delete an NTP server is available only if the appliance has two or more NTP servers already configured.

4. Type A to apply all the changes that you made, or type M to return to the Junos Space Settings Menu without applying the changes.

## Retrieving and Transferring System Log Files

You can retrieve system log files using Secure Copy Protocol (SCP) if the network is functional, or a USB device if the network is down.

**NOTE:** To save the system log files to a USB device, the device must be connected to the Junos Space Appliance.

To retrieve system log files, do the following:

1. On the Junos Space Settings Menu, type 4 at the prompt.
2. On the subsequent menu, you can do the following:
  - To save the log files to a USB device, type 1 and follow the prompts on the CLI.

Junos Space Network Management Platform retrieves the log files on all cluster (fabric) nodes and combines the log files into a tar file. After the file is created, you can copy the file onto a USB device.

- Alternatively, to transfer the log files using SCP, type 2 and follow the prompts on the CLI.

Junos Space Network Management Platform retrieves the log files on all cluster (fabric) nodes and combines the log files into a tar file. After the file is created, you can transfer the file to a remote server.

3. Type **A** to apply all the changes that you made, or type **M** to return to the Junos Space Settings Menu without applying the changes.

## Changing Firewall and SSH Settings

By default, the *firewall* and SSH are enabled on the Junos Space Appliance.

To change the firewall and SSH settings, do the following:

1. On the Junos Space Settings Menu, type 5 at the prompt.
2. (Optional) To change the firewall setting:
  - If the firewall is currently enabled, type 1 to disable the firewall.
  - If the firewall is currently disabled, type 1 to enable the firewall.
3. (Optional) To change the SSH setting:
  - If SSH is currently enabled, type 2 to disable SSH.
  - If SSH is currently disabled, type 2 to enable SSH.
4. Type **A** to apply all the changes that you made, or type **M** to return to the Junos Space Settings Menu without applying the changes.

## Accessing the Shell

You can access a shell and run shell commands that can help during debugging. Do the following:

1. On the Junos Space Settings Menu, type 6 at the prompt.  
You are prompted to enter a password.
2. Type the password for the administrator (admin user).  
You are taken to a shell where you can run commands. When you are in shell mode, the prompt is of the format `[root@identifier ~]#` format, where *identifier* is a unique identifier for the node.
3. To exit the shell, type `exit` and press Enter.  
You are taken to the Junos Space Settings Menu.

## Applying or Cancelling Changes to Settings

Changes to the appliance settings are not applied immediately but are queued in the order that you made the changes. You must explicitly apply the changes before quitting the Junos Space CLI so that the changes to the appliance settings are made. Alternatively, you can choose to cancel some or all changes that you made.

To apply all changes or cancel one or more changes, do one of the following:

- To apply all changes, type A.

The changes are applied and you are taken to the Junos Space Settings Menu.

**NOTE:** For some changes, you may be asked to enter your administrator password before the change is applied.

- To cancel a change, type the number corresponding to that change, and follow the prompts on the CLI.
- To cancel all changes and quit the console session, type C.

### RELATED DOCUMENTATION

---

[Configuring a Junos Space Appliance as a Junos Space Node | 97](#)

---

[Configuring a Junos Space Appliance as a Standalone or Primary FMPM Node | 123](#)

---

[Configuring a Junos Space Appliance as a Backup or Secondary FMPM Node for High Availability | 134](#)

---

[Booting the Junos Space Appliance | 96](#)

---

[Junos Space Ethernet Interfaces Overview | 4](#)

---

[NTP Time Source for a Junos Space Appliance | 8](#)

# 5

PART

## Maintenance and Replacing Components

---

Replacing Components | 161

Maintenance | 178

---



# Replacing Components

## IN THIS CHAPTER

- [Installing and Removing JA2500 Junos Space Appliance Hardware Components | 161](#)
- [Replacing the AC Power Supply Cord on a Junos Space Appliance | 162](#)
- [Replacing the AC Power Supply Module on a Junos Space Appliance | 164](#)
- [Replacing the DC Power Supply Cable on a Junos Space Appliance | 167](#)
- [Replacing the DC Power Supply Module on a Junos Space Appliance | 169](#)
- [Replacing the Fan on a Junos Space Appliance | 171](#)
- [Replacing the Hard Disk on a JA2500 Junos Space Appliance | 174](#)

## Installing and Removing JA2500 Junos Space Appliance Hardware Components

The JA2500 Junos Space Appliance chassis is a rigid sheet-metal structure that houses the hardware components. The field-replaceable units (FRUs) in the JA2500 appliance are as follows:

- AC power supply
- Cooling fan
- DC power supply
- Hard disk

**NOTE:** Remove the fan module only when you need to replace a non functioning fan.

Refer to the following topics for instructions on how to install and remove hardware components:

- ["Replacing the AC Power Supply Module on a Junos Space Appliance" on page 164](#)
- ["Replacing the AC Power Supply Cord on a Junos Space Appliance" on page 162](#)

- ["Replacing the DC Power Supply Module on a Junos Space Appliance" on page 169](#)
- ["Replacing the DC Power Supply Cable on a Junos Space Appliance" on page 167](#)
- ["Replacing the Fan on a Junos Space Appliance" on page 171](#)
- ["Replacing the Hard Disk on a JA2500 Junos Space Appliance" on page 174](#)

## RELATED DOCUMENTATION

[AC Power Supply in Junos Space Appliances | 25](#)

[DC Power Supply in Junos Space Appliances | 27](#)

[Field-Replaceable Units on the JA2500 Junos Space Appliance | 3](#)

## Replacing the AC Power Supply Cord on a Junos Space Appliance

### IN THIS SECTION

- [Disconnecting the AC Power Supply Cord | 162](#)
- [Connecting the AC Power Supply Cord | 163](#)

**NOTE:** If only one power supply module is installed in your Junos Space Appliance, you must power off the appliance before replacing the power supply cord.

This topic contains the following sections:

### Disconnecting the AC Power Supply Cord

To disconnect an AC power supply cord from a Junos Space Appliance, do the following:

1. (Optional) Attach an electrostatic discharge (ESD) grounding strap to your bare wrist, and connect the strap to an external ESD point.
2. If the AC power source outlet has a power switch, set it to the OFF position. If the AC power source outlet does not have a power switch, gently pull out the plug end of the power cord connected to the power source outlet.

3. If the power cord has the retainer clip and adjustment nut installed, turn the adjustment nut so that the power cord can be removed from the slot in the adjustment nut.
4. Unplug the power cord from the power supply module.

### Connecting the AC Power Supply Cord

To connect an AC power supply cord to a Junos Space Appliance, do the following:

1. (Optional) Attach an electrostatic discharge (ESD) grounding strap to your bare wrist, and connect the strap to an external ESD point.
2. If the power cord retainer clip is not installed on the power supply module, squeeze the two sides of the power cord retainer clip and insert the L-shaped ends of the wire clip into the holes in the bracket on each side of the AC power cord inlet on the power supply module, as shown in [Figure 15 on page 163](#).

**Figure 15: AC Power Supply Cord with Retainer**

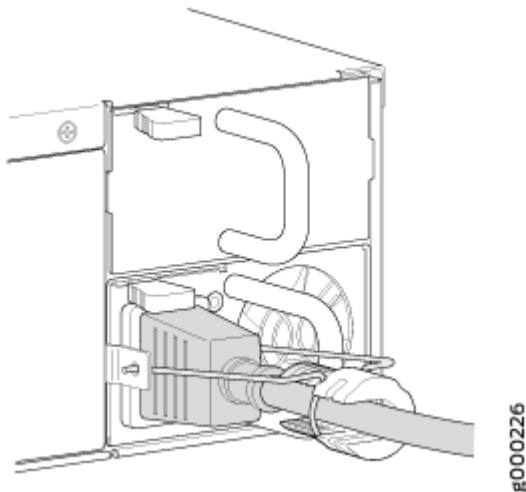

3. Locate a replacement power cord with the type of plug appropriate for your geographical location.
4. If the AC power source outlet has a power switch, set it to the OFF position.
5. Insert the power cord plug into an external AC power source outlet.
6. If the AC power source outlet has a power switch, set it to the ON position.
7. Push the power cord into the slot in the adjustment nut of the power cord retainer clip. Turn the nut until it is tight against the base of the coupler and the slot in the nut is turned 90° from the top of the appliance, as shown in [Figure 15 on page 163](#).
8. Connect the power cord to the power supply module.
9. Verify that the power cord does not block the air exhaust and access to device components, or drape where people could trip on it.

The Junos Space Appliance starts powering on when you supply power to the power supply module. If the power supply cord is correctly installed, the LED on the power supply module displays green when the power supply module is powering the appliance, and amber when the power supply module is in standby mode (not powering the appliance).

## RELATED DOCUMENTATION

[AC Power Cord Specifications for Junos Space Appliances | 23](#)

[AC Power Supply in Junos Space Appliances | 25](#)

[Field-Replaceable Units on the JA2500 Junos Space Appliance | 3](#)

[Replacing the AC Power Supply Module on a Junos Space Appliance | 164](#)

## Replacing the AC Power Supply Module on a Junos Space Appliance

### IN THIS SECTION

- [Removing the AC Power Supply Module | 164](#)
- [Installing the AC Power Supply Module | 165](#)

Ensure that you have the following parts and tools available to remove the power supply module from the appliance chassis:

- (Optional) Electrostatic discharge (ESD) grounding strap
- An antistatic bag or an antistatic mat

**NOTE:** If only one power supply module is installed in your Junos Space Appliance, you must power off the appliance before removing the power supply module.

This topic has the following sections:

### Removing the AC Power Supply Module

To remove the AC power supply module, do the following:

1. Place an antistatic bag or an antistatic mat on a flat, stable surface.
2. (Optional) Attach an electrostatic discharge (ESD) grounding strap to your bare wrist, and connect the strap to an external ESD point.
3. If the AC power source outlet has a power switch, set it to the OFF position.
4. Gently pull out the plug end of the power cord connected to the power source outlet.
5. Remove the power cord from the power supply faceplate by detaching the power cord retainer and gently pulling out the socket end of the power cord connected to the power supply faceplate.
6. Slide the locking ejector lever to the right, as shown in [Figure 16 on page 165](#), until it is in its furthest position.

**Figure 16: Removing the AC Power Supply Module**

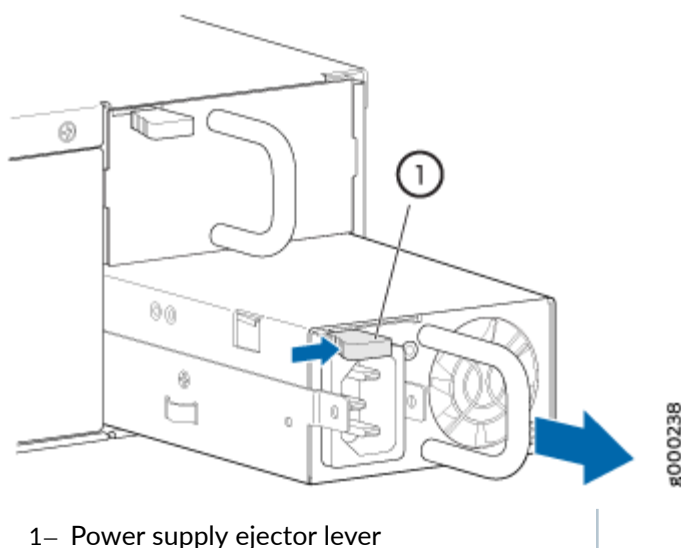

7. Grasp the power supply handle and pull firmly to slide the power supply module halfway out of the appliance.
8. Place one hand under the power supply module to support it and slide it completely out of the appliance. Take care not to touch power supply components, pins, leads, or solder connections.
9. Place the power supply module in the antistatic bag or on the antistatic mat on a flat, stable surface.

### Installing the AC Power Supply Module

To install the AC power supply module, do the following:

1. Remove the replacement power supply module from its antistatic bag, taking care not to touch power supply pins, leads, or solder connections.
2. (Optional) Attach an electrostatic discharge (ESD) grounding strap to your bare wrist, and connect the strap to an external ESD point.

3. If the power supply slot has a cover panel on it, slide the ejector lever (on the cover panel) to the right and then take out the cover. Save the cover panel for later use.
4. Insert and push the new power supply module into the slot, as shown in [Figure 17 on page 166](#), until the ejector lever locks.

**Figure 17: Installing the AC Power Supply Module**

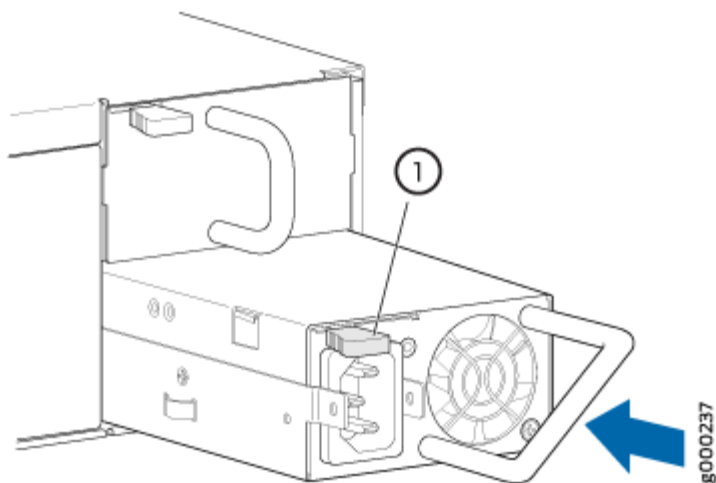

1– Power supply ejector lever

5. Connect the AC power cord to the power supply module. For more information, see the ["Connecting AC Power to the Junos Space Appliance" on page 88](#) topic.
6. If the appliance is not powered on, power on the appliance by pressing the switch on the rear panel, next to the power supply module.

The Junos Space Appliance starts powering on when you supply power to the power supply module. If the power supply module is correctly installed and functioning normally, the LED on the power supply module displays green when the power supply module is powering the appliance, and amber when the power supply module is in standby mode (not powering the appliance).

## RELATED DOCUMENTATION

[AC Power Cord Specifications for Junos Space Appliances | 23](#)

[AC Power Supply in Junos Space Appliances | 25](#)

[Field-Replaceable Units on the JA2500 Junos Space Appliance | 3](#)

## Replacing the DC Power Supply Cable on a Junos Space Appliance

### IN THIS SECTION

- [Removing the DC Power Supply Cable | 167](#)
- [Connecting the DC Power Supply Cable | 168](#)

Ensure that you have the following parts and tools available to remove the power supply cable from the appliance chassis:

- (Optional) ESD grounding strap
- Phillips (+) screwdriver, number 2
- An antistatic bag or an antistatic mat

**NOTE:** If only one power supply module is installed in your appliance, you must power off the appliance before removing the power supply cable.

This topic has the following sections:

### Removing the DC Power Supply Cable

To remove a DC power supply cable from a Junos Space appliance, do the following:

1. (Optional) Attach an electrostatic discharge (ESD) grounding strap to your bare wrist, and connect the strap to an external ESD point.
2. Switch off the external circuit breakers, if they are present, for all the cables attached to the power supply module. Make sure that the voltage across the DC power source cable leads is 0 V and that there is no chance that the cables might become active during the removal process.
3. Remove the clear plastic cover over the terminal studs on the faceplate.
4. Remove the screws from the terminals, using a Phillips screwdriver, number 2 to loosen and remove the screws. Save the screws.
5. Remove the cable lugs from the terminals.
6. Remove the screw from the grounding terminal using a Phillips screwdriver, number 2 to loosen and remove the screw. Save the screw.
7. Remove the grounding lug from the terminal.
8. Carefully remove the power cable from the DC power source.

**NOTE:** Ensure that the cable is not touching or in the way of any components, and that it does not drape where people could trip on it.

## Connecting the DC Power Supply Cable

To connect a DC power supply cable to a Junos Space appliance, do the following:

1. (Optional) Attach an electrostatic discharge (ESD) grounding strap to your bare wrist, and connect the strap to an external ESD point.
2. Switch off the external circuit breakers, if they are present, for all the cables attached to the power supply. Make sure that the voltage across the DC power source cable leads is 0 V and that there is no chance that the cables might become active during the removal process.
3. Remove the clear plastic cover over the terminal studs on the faceplate.
4. Attach the power cable to the DC power source. For more information on how to connect the DC power cables to the appliance, see the "[Connecting DC Power to the Junos Space Appliance](#)" on [page 90](#) topic.
5. Replace the clear plastic cover over the terminal studs on the faceplate.
6. Connect the grounding lug to the grounding terminal.
7. Switch on the external circuit breakers, if they are present, for all the cables attached to the power supply.

The Junos Space Appliance starts powering on when you supply power to the power supply module. If the power supply module is correctly installed and functioning normally, the LED on the power supply module displays green when the power supply module is powering the appliance, and amber when the power supply module is in standby mode (not powering the appliance).

### RELATED DOCUMENTATION

---

[DC Power Supply in Junos Space Appliances | 27](#)

---

[Field-Replaceable Units on the JA2500 Junos Space Appliance | 3](#)

---

[Replacing the DC Power Supply Module on a Junos Space Appliance | 169](#)



## Replacing the DC Power Supply Module on a Junos Space Appliance

### IN THIS SECTION

- [Removing the DC Power Supply Module | 169](#)
- [Installing a DC Power Supply Module | 170](#)

Ensure that you have the following parts and tools available to replace the power supply module from the appliance chassis:

- (Optional) ESD grounding strap
- Phillips (+) screwdriver, number 2
- An antistatic bag or an antistatic mat

**NOTE:** If only one power supply module is installed in your appliance, you must power off the appliance before replacing the power supply module.

This topic has the following sections:

### Removing the DC Power Supply Module

To remove the DC power supply module from a Junos Space Appliance, do the following:

1. Switch off the dedicated facility circuit breaker for the power supply module being removed.
2. (Optional) Attach an electrostatic discharge (ESD) grounding strap to your bare wrist, and connect the strap to an external ESD point.
3. Make sure that the voltage across the DC power source cable leads is 0 V and that there is no chance that the cables might become active during the removal process.
4. Remove the clear plastic cover protecting the terminal studs on the faceplate.
5. Remove the screws from the terminals, using a Phillips screwdriver, number 2 to loosen and remove the screws. Save the screws.
6. Remove the cable lugs from the terminals.
7. Remove the screw on the grounding terminal by using the screwdriver. Save the screw.
8. Remove the grounding lug from the grounding terminal.
9. Carefully move the power cables out of the way.

- Slide the ejector lever to the right, as shown in [Figure 18 on page 170](#), until it is in its furthest position.

**Figure 18: Removing a DC Power Supply Module**

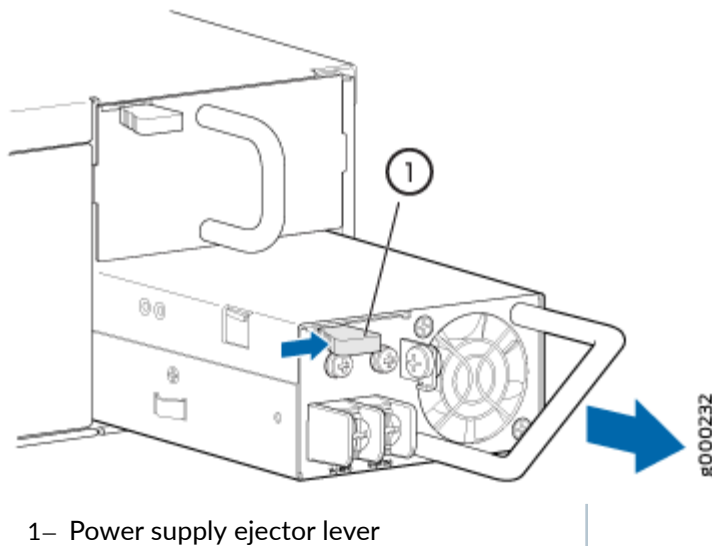

- Grasp the handle of the power supply module and pull firmly to slide the power supply module halfway out of the chassis.
- Place one hand under the power supply module to support it and slide it completely out of the appliance. Take care not to touch power supply components, pins, leads, or solder connections.
- Place the power supply module in the antistatic bag or on the antistatic mat placed on a flat, stable surface.

### Installing a DC Power Supply Module

To install a DC power supply module, do the following:

- (Optional) Attach an electrostatic discharge (ESD) grounding strap to your bare wrist, and connect the strap to an external ESD point.
- Taking care not to touch power supply pins, leads, or solder connections, remove the replacement power supply module from the bag.
- Using both hands, slide the replacement power supply module straight into the chassis, as shown in [Figure 19 on page 171](#), until the power supply is fully seated in the chassis slot and the ejector lever locks.

Figure 19: Installing a DC Power Supply Module

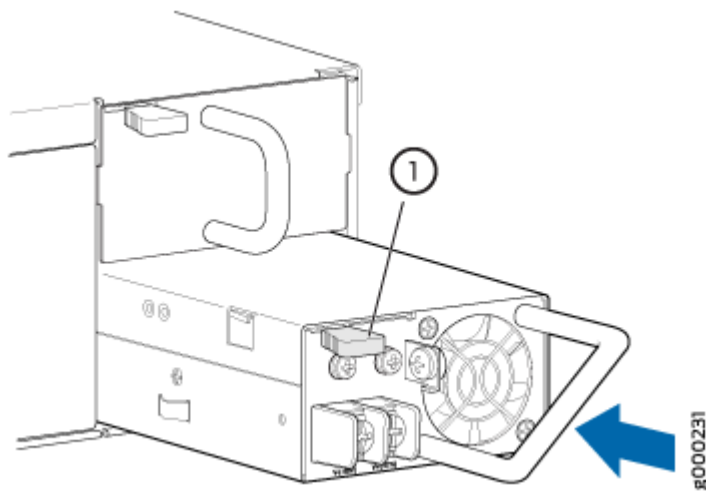

1– Power supply ejector lever

4. Connect the DC source power to the appliance. For more information, see the ["Connecting DC Power to the Junos Space Appliance" on page 90](#) topic.

## RELATED DOCUMENTATION

[DC Power Supply in Junos Space Appliances | 27](#)

[Field-Replaceable Units on the JA2500 Junos Space Appliance | 3](#)

[Replacing the DC Power Supply Cable on a Junos Space Appliance | 167](#)

## Replacing the Fan on a Junos Space Appliance

### IN THIS SECTION

- [Removing the Fan | 172](#)
- [Installing the Fan | 173](#)

The Junos Space appliance ships with two field-replaceable fans that are hot-swappable. You can remove and replace a fan without powering off the appliance or disrupting any functions.

When a fan fails, the full cooling load switches to the remaining fan and the red Hardware Fault LED on the front panel of the appliance blinks and an alarm sounds.

**NOTE:** The LEDs on the front panel of the JA2500 are arranged vertically, as shown in [Figure 20](#) on page 172.

**Figure 20: JA2500 Appliance Front Panel Status LEDs**

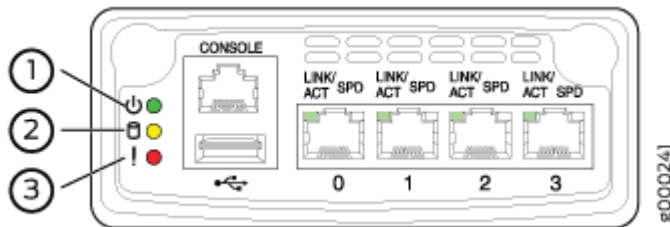

1– Power LED

2– Hard Disk Activity LED

3– Hardware Fault LED



**CAUTION:** The Junos Space appliance should not run on one fan for an extended period of time. Failed fans should be replaced as soon as possible.

Ensure that you have the following parts and tools available to remove the fan from the appliance chassis:

- (Optional) Electrostatic discharge (ESD) grounding strap
- (Optional) An antistatic bag or an antistatic mat

## Removing the Fan

To remove a fan from a Junos Space appliance, do the following:

1. (Optional) Place the antistatic bag or antistatic mat on a flat, stable surface.
2. (Optional) Attach an ESD grounding strap to your bare wrist, and connect the strap to an external ESD point.
3. Press the latch at the side of the fan, as shown [Figure 21](#) on page 173 to release the fan.

Figure 21: Removing a Fan

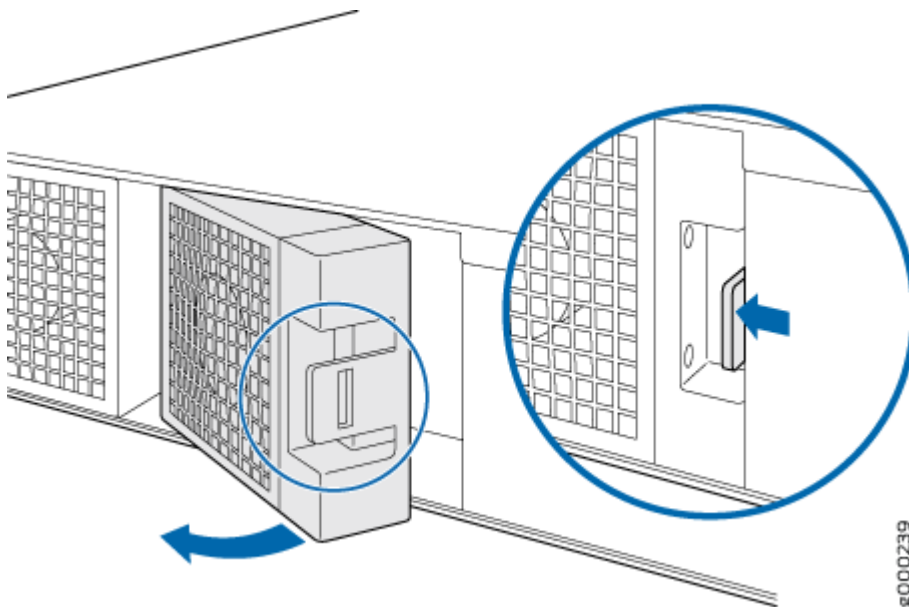

4. Pull the fan module out of the chassis.
5. (Optional) Place the fan module in the antistatic bag or on the antistatic mat placed on a flat, stable surface.

### Installing the Fan

To install a fan in a Junos Space appliance, do the following:

1. (Optional) Attach an electrostatic discharge (ESD) grounding strap to your bare wrist, and connect the strap to an external ESD point.
2. Remove the replacement fan module from its antistatic bag.
3. Insert the replacement fan into the slot for the fan module, as shown in [Figure 22 on page 174](#), until the latch locks and you hear a clicking sound.

Figure 22: Installing a Fan

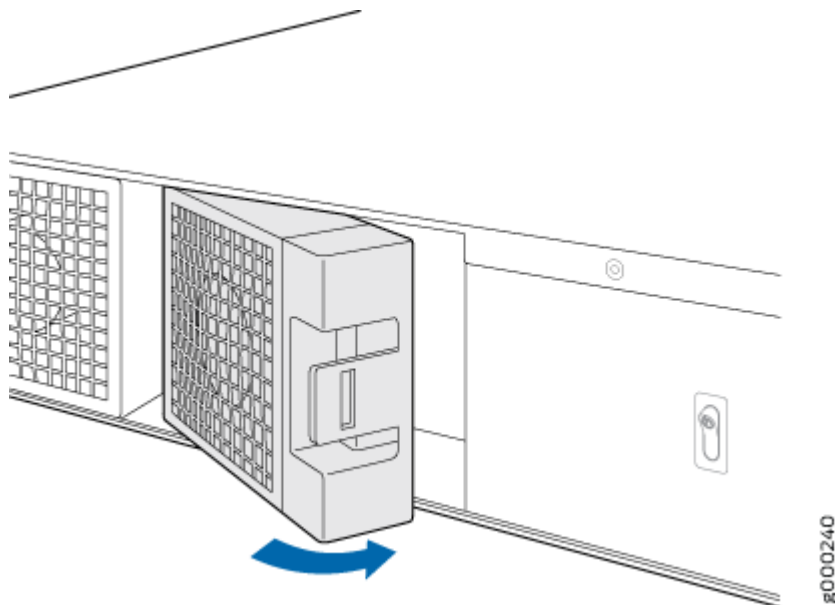

When you install a replacement fan, the cooling load is distributed back evenly across both the fans, and the Hardware Fault LED stops blinking and the alarm turns off.

#### RELATED DOCUMENTATION

[Field-Replaceable Units on the JA2500 Junos Space Appliance | 3](#)

[Installing and Removing JA2500 Junos Space Appliance Hardware Components | 161](#)

## Replacing the Hard Disk on a JA2500 Junos Space Appliance

#### IN THIS SECTION

- [Removing the Hard Disk | 175](#)
- [Installing the Hard Disk | 176](#)

The Junos Space JA2500 appliance ships with six hard disk drives in RAID 10 array configuration. The hot-swappable drives are externally accessible in field-replaceable trays. You can remove and replace a

hard disk without powering off the appliance or disrupting any functions performed by the appliance. If a hard drive fails, the Hard Disk Fault LED on the hard disk turns on and an alarm sounds.

**Figure 23: JA2500 Appliance Hard Disk Status LEDs**

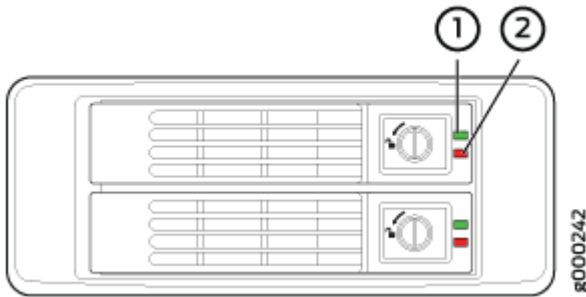

1– Hard Disk Activity LED

2– Hard Disk Fault LED

Ensure that you have the following parts and tools available to remove the hard disk from the appliance chassis:

- (Optional) Electrostatic discharge (ESD) grounding strap
- Flat screwdriver
- An antistatic bag or an antistatic mat

## Removing the Hard Disk

To remove a hard disk from the JA2500 appliance, do the following:

1. Place the antistatic bag or antistatic mat on a flat, stable surface.
2. (Optional) Attach an ESD grounding strap to your bare wrist, and connect the strap to an external ESD point.
3. Turn the hard disk locking screw counterclockwise to the unlock position, as shown in [Figure 24 on page 176](#), to unlock the hard disk lever.
4. Push the screw knob (button) in so that the hard disk lever is released.
5. Gently pull the hard disk lever outwards, and slide the hard disk out of the slot. Keep one hand underneath the hard disk to support it while removing it from the chassis.
6. Place the hard drive in the antistatic bag or on the antistatic mat placed on a flat, stable surface.

Figure 24: Removing a Hard Disk

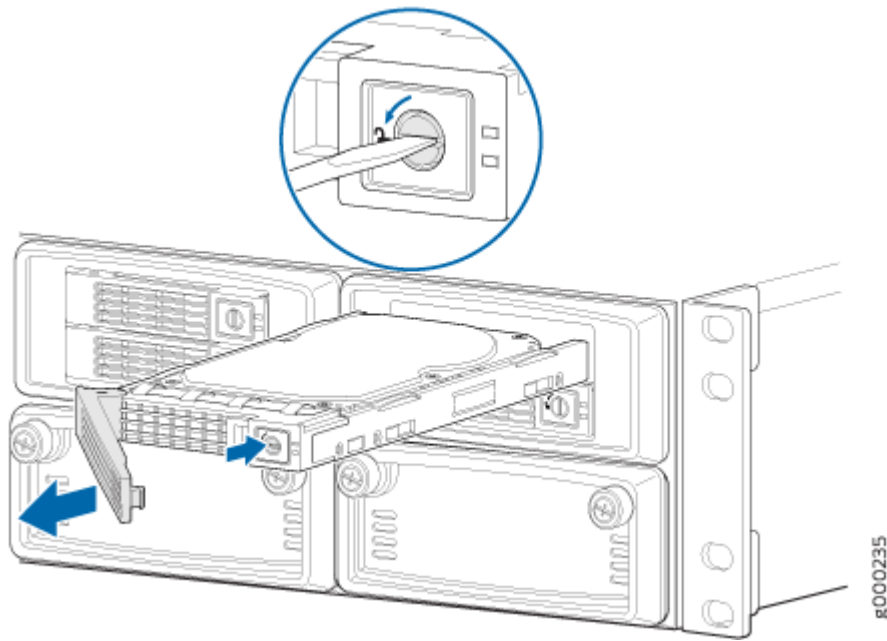

## Installing the Hard Disk

To install a hard disk in the JA2500 appliance, do the following:

1. (Optional) Attach an ESD grounding strap to your bare wrist, and connect the strap to an external ESD point.
2. Remove the replacement hard disk from its antistatic bag.
3. Slide the hard disk into the hard disk slot.
4. Push the hard disk lever, as shown in [Figure 25 on page 177](#), until it closes with a click to ensure that the hard disk is secured firmly in the slot.
5. Using a flat screwdriver, turn the screw clockwise to the locked position so that the notch in the screw is oriented vertically.



Figure 25: Installing a Hard Disk

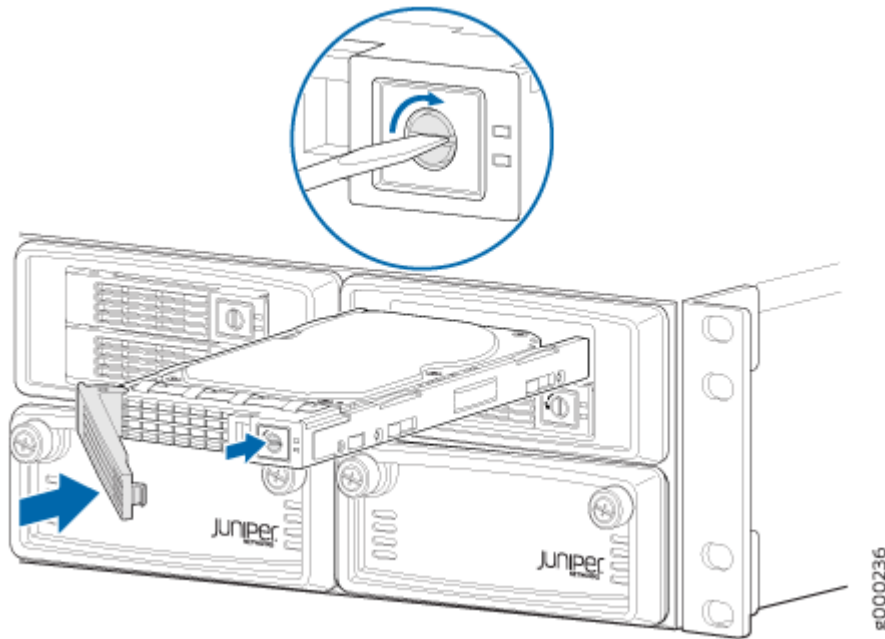

When you install a replacement hard disk, the alarm shuts off when the new drive is sensed and the red Hard Disk Fault LED on the new hard drive starts blinking, which indicates that the drive is being rebuilt. When the drive is rebuilt, the red LED goes out.

#### RELATED DOCUMENTATION

[Field-Replaceable Units on the JA2500 Junos Space Appliance | 3](#)

[Installing and Removing JA2500 Junos Space Appliance Hardware Components | 161](#)

# Maintenance

## IN THIS CHAPTER

- [Maintaining the Junos Space Appliance | 178](#)

## Maintaining the Junos Space Appliance

### IN THIS SECTION

- [Purpose | 178](#)
- [Action | 178](#)

### Purpose

For optimum performance of the Junos Space appliance, perform preventive maintenance procedures.

### Action

On a regular basis, ensure that you do the following:

- Keep the site as dust-free as possible; dust can clog air intake vents and filters, reducing the efficiency of the appliance cooling system.
- Inspect the site to ensure that the grounding and power cables connected to the Junos Space appliance are securely in place and that there is no moisture accumulating near the appliance.
- Ensure that the power and grounding cables are arranged so that they do not obstruct access to other components.
- Keep the area around the chassis free from dust and conductive material, such as metal flakes.

- Maintain ambient airflow for normal appliance operation. If the airflow is blocked or restricted, or if the intake air is too warm, the appliance might overheat.

## RELATED DOCUMENTATION

[Monitoring the Cooling Fans in a Junos Space Appliance | 183](#)

---

[Monitoring the Power Supply in a Junos Space Appliance | 186](#)

---

[Monitoring the RAID Array for the JA2500 Junos Space Appliance | 188](#)



# Troubleshooting

---

[Troubleshooting Procedures | 181](#)

[Monitoring the Appliance | 183](#)

[Returning Hardware | 194](#)

---

# Troubleshooting Procedures

## IN THIS CHAPTER

- [Troubleshooting Junos Space Ethernet Interface eth3 Connectivity | 181](#)

## Troubleshooting Junos Space Ethernet Interface eth3 Connectivity

### IN THIS SECTION

- [Problem | 181](#)
- [Solution | 181](#)

### Problem

#### Description

If you have connectivity issues with the Junos Space Ethernet interface eth3, you can use this procedure to troubleshoot the connectivity issues.

#### Solution

Before you begin, do the following:

- Connect a management device (PC or laptop) to the appliance using the management console and power on both the appliance and the management device. Alternatively, you can connect to the appliance via telnet or SSH if the appliance is accessible via the network.
- Log in to the appliance using the administrator username (**admin**) and password.

- Ensure that you have accessed the shell. Refer to the *Accessing the Shell* section in the "[Changing Network and System Settings for a Junos Space Appliance](#)" on page 151 topic for details.

To troubleshoot connectivity issues from the eth3 interface, do the following:

1. Force traffic to use the Ethernet interface eth3 interface by executing one of the following commands from the shell:

- `ping -I eth3 destination ip address`
- `ping -I eth3 interface ip address destination ip address`

2. If no packets are received, do the following:

- Verify the gateway IP address in the devint routing table by executing the following command from the shell:

```
ip route show table devint
```

The gateway IP address should be the one configured for routing device management traffic. Refer to the *Changing Network Settings* section in the "[Changing Network and System Settings for a Junos Space Appliance](#)" on page 151 for information about changing the default gateway for device management traffic.

- Check the physical connectivity of Ethernet interface eth3.

## RELATED DOCUMENTATION

| [Junos Space Ethernet Interfaces Overview](#) | 4

# Monitoring the Appliance

## IN THIS CHAPTER

- [Monitoring the Cooling Fans in a Junos Space Appliance | 183](#)
- [Monitoring the Power Supply in a Junos Space Appliance | 186](#)
- [Monitoring the RAID Array for the JA2500 Junos Space Appliance | 188](#)

## Monitoring the Cooling Fans in a Junos Space Appliance

### IN THIS SECTION

- [Purpose | 183](#)
- [Action | 183](#)
- [Meaning | 185](#)

### Purpose

For optimal cooling of the Junos Space appliance, verify the condition of the fans.

### Action

Monitor the status of the fans. The cooling fans work in unison to cool the appliance components. An alarm is triggered when a fan fails and the Hardware Fault LED on the appliance front panel starts blinking. When one fan fails, the remaining fan begins to run at full speed.

To monitor the fans, do the following:

1. Log in to the appliance as the admin user.

The Junos Space Settings Menu appears.

2. Type 6, which is the (Debug) run shell option.

You are prompted to enter your password.

3. Type the password for the admin user and press Enter.

You are taken to the shell.

4. To view the status of the cooling fans, execute the following command:

```
[root@host ~]# sensors
```

**NOTE:** The Junos Space installer automatically sets up the Linux-monitoring sensors (lm\_sensors) and configures lm\_sensors to run at startup.

## Sample Output

### command-name

```
nct6776-isa-0a30
Adapter: ISA adapter
Vcore:      +0.66 V (min = +0.00 V, max = +1.74 V)
in1:        +1.51 V (min = +0.00 V, max = +0.00 V)  ALARM
AVCC:       +3.41 V (min = +2.98 V, max = +3.63 V)
VCC:        +3.39 V (min = +2.98 V, max = +3.63 V)
in4:        +1.13 V (min = +0.00 V, max = +0.00 V)  ALARM
in5:        +1.01 V (min = +0.00 V, max = +0.00 V)  ALARM
3VSB:       +3.42 V (min = +2.98 V, max = +3.63 V)
Vbat:       +3.38 V (min = +2.70 V, max = +3.30 V)  ALARM
fan1:        0 RPM (min = 0 RPM)  ALARM
fan2:        0 RPM (min = 0 RPM)  ALARM
SYSTIN:     +27.0Â°C (high = +0.0Â°C, hyst = +0.0Â°C)  ALARM  sensor = thermistor
CPUTIN:     +97.5Â°C (high = +80.0Â°C, hyst = +75.0Â°C)  ALARM  sensor = diode
AUXTIN:     +25.5Â°C (high = +80.0Â°C, hyst = +75.0Â°C)  sensor = thermistor
cpu0_vid:   +2.050 V

w83793-i2c-0-2f
Adapter: SMBus I801 adapter at f040
VcoreA:     +0.22 V (min = +0.60 V, max = +1.21 V)  ALARM
VcoreB:     +0.65 V (min = +0.60 V, max = +1.21 V)
```



```

in2:      +1.05 V (min = +0.99 V, max = +1.33 V)
in3:      +1.49 V (min = +0.40 V, max = +0.67 V)  ALARM
in4:      +0.53 V (min = +1.34 V, max = +1.65 V)  ALARM
in5:      +1.04 V (min = +2.96 V, max = +3.63 V)  ALARM
in6:      +0.23 V (min = +0.90 V, max = +1.10 V)  ALARM
+5V:      +5.07 V (min = +4.52 V, max = +5.50 V)
5VSB:     +5.07 V (min = +4.52 V, max = +5.50 V)
Vbat:     +0.00 V (min = +2.70 V, max = +3.30 V)
fan1:     0 RPM (min = 329 RPM)  ALARM
fan2:     0 RPM (min = 329 RPM)  ALARM
fan3:     3206 RPM (min = 329 RPM)
fan4:     3461 RPM (min = 329 RPM)
fan5:     0 RPM (min = 329 RPM)  ALARM
fan6:     0 RPM (min = 329 RPM)  ALARM
fan7:     0 RPM (min = 329 RPM)  ALARM
fan8:     0 RPM (min = 329 RPM)  ALARM
fan9:     0 RPM (min = 329 RPM)  ALARM
fan11:    0 RPM (min = 329 RPM)  ALARM
fan12:    0 RPM (min = 329 RPM)  ALARM
temp1:    +33.0Â°C (high = +70.0Â°C, hyst = +65.0Â°C) sensor = Intel PECI
temp2:    -128.0Â°C (high = +60.0Â°C, hyst = +55.0Â°C) sensor = Intel PECI
temp3:    -128.0Â°C (high = +60.0Â°C, hyst = +55.0Â°C) sensor = Intel PECI
temp4:    -128.0Â°C (high = +60.0Â°C, hyst = +55.0Â°C) sensor = Intel PECI
temp5:    +37.0Â°C (high = +70.0Â°C, hyst = +65.0Â°C) sensor = thermistor
temp6:    +34.0Â°C (high = +70.0Â°C, hyst = +65.0Â°C) sensor = thermistor
beep_enable:disabled

```

## Meaning

The output of the `sensors` command provides information about the fan speeds and whether an alarm has been triggered. In the output, fans 3 and 4 represent the two rear chassis fans. The speed of the fans (in revolutions per minute [RPM]) and an indication of an alarm, if any, are displayed.

## RELATED DOCUMENTATION

[Maintaining the Junos Space Appliance | 178](#)

[Monitoring the Power Supply in a Junos Space Appliance | 186](#)

[Monitoring the RAID Array for the JA2500 Junos Space Appliance | 188](#)

## Monitoring the Power Supply in a Junos Space Appliance

### IN THIS SECTION

- Purpose | 186
- Action | 186
- Meaning | 187

### Purpose

For optimal performance of the Junos Space appliance, verify the condition of the power supply module or modules installed in the appliance.

**NOTE:** Routinely check the LED on the power supply module. The Power Supply Module LED is green when the power supply module is powering the appliance, and amber when the power supply module is on but not powering the appliance (standby mode). If there is a problem with the power supply module, the Hardware Fault LED, located on the front panel of the appliance, starts blinking and an alarm sounds.

For information on how to replace an AC power supply module, see ["Replacing the AC Power Supply Module on a Junos Space Appliance" on page 164](#). For information on how to replace a DC power supply module, see ["Replacing the DC Power Supply Module on a Junos Space Appliance" on page 169](#).

### Action

- Monitor the power supply modules. Do the following:
  1. Log in to the appliance as the admin user.  
The Junos Space Settings Menu appears.
  2. Type 6, which is the (Debug) run shell option.  
You are prompted to enter your password.
  3. Type the password for the admin user and press Enter.  
You are taken to the shell.

#### 4. Run the power status monitoring script:

```
[root@host ~]#/usr/local/bin/pwr_status_jnpr_v2.sh
```

**NOTE:** The Junos Space installer automatically installs the i2c-tools package and the power status monitoring script.

A sample output of the power monitoring script is as follows:

### Sample Output

#### command-name

```
Juniper Product: JA2500

System Power Supply Status:
-----

PS1 BTM MODULE: PRESENT
PS1 FAN STATUS: GOOD
PS1 OTP:          GOOD (<55C)
PS1 POWER:        GOOD

PS2 TOP MODULE: NOT DETECTED
```

### Meaning

The output of the `pwr_status_jnpr_v2.sh` script provides status information about the power supply modules installed in the appliance.

### RELATED DOCUMENTATION

[Maintaining the Junos Space Appliance | 178](#)

[Monitoring the Cooling Fans in a Junos Space Appliance | 183](#)

[Monitoring the RAID Array for the JA2500 Junos Space Appliance | 188](#)

## Monitoring the RAID Array for the JA2500 Junos Space Appliance

### IN THIS SECTION

- Purpose | 188
- Action | 188
- Meaning | 193

### Purpose

For optimal performance of the JA2500 appliance, monitor the status of the RAID volume installed in the appliance.

### Action

- Monitor the RAID controller for RAID failure events:

Do the following:

1. Log in to the appliance as the admin user.

The Junos Space Settings Menu appears.

2. Type 6, which is the (Debug) run shell option.

You are prompted to enter your password.

3. Type the password for the admin user and press Enter.

You are taken to the shell.

4. Obtain the current status of the RAID volume by executing the following command:

```
[root@host ~]# sas2ircu 0 status
```

The output of this command provides information about the RAID volume, like volume ID, volume status, volume state, and so on. The following is a sample output.

```
LSI Corporation SAS2 IR Configuration Utility.
Version 16.00.00.00 (2013.03.01)
Copyright (c) 2009-2013 LSI Corporation. All rights reserved.

Background command progress status for controller 0...
IR Volume 1
  Volume ID                : 1314
  Current operation        : None
  Volume status            : Enabled
  Volume state             : Optimal
  Volume wwid              : 0ad030be716b5c70
  Physical disk I/Os      : Not quiesced
SAS2IRCU: Command STATUS Completed Successfully.
SAS2IRCU: Utility Completed Successfully.
```

- (Optional) If the volume state (in the output of the preceding command) displays Degraded, then check the physical drive status using the following command:

```
[root@host ~]# sas2ircu 0 display
```

The following is a sample output.

```
LSI Corporation SAS2 IR Configuration Utility.
Version 16.00.00.00 (2013.03.01)
Copyright (c) 2009-2013 LSI Corporation. All rights reserved.

Read configuration has been initiated for controller 0
-----
Controller information
-----
Controller type           : SAS2308_1
BIOS version              : 7.25.00.00
Firmware version         : 16.00.00.00
Channel description      : 1 Serial Attached SCSI
Initiator ID             : 0
Maximum physical devices : 1007
Concurrent commands supported : 8192
```

```

Slot                : 33
Segment             : 0
Bus                 : 2
Device              : 0
Function            : 0
RAID Support        : Yes

```

---

IR Volume information

---

IR volume 1

```

Volume ID           : 1314
Volume Name         : RAID-10
Status of volume    : Okay (OKY)
Volume wwid         : 0ad030be716b5c70
RAID level          : RAID10
Size (in MB)        : 2858160
Physical hard disks :
PHY[0] Enclosure#/Slot# : 1:4
PHY[1] Enclosure#/Slot# : 1:5
PHY[2] Enclosure#/Slot# : 1:6
PHY[3] Enclosure#/Slot# : 1:0
PHY[4] Enclosure#/Slot# : 1:1
PHY[5] Enclosure#/Slot# : 1:2

```

---

Physical device information

---

Initiator at ID #0

Device is a Hard disk

```

Enclosure #        : 1
Slot #             : 0
SAS Address        : 5000c50-0-33e4-b421
State              : Optimal (OPT)
Size (in MB)/(in sectors) : 953869/1953525167
Manufacturer       : SEAGATE
Model Number       : ST91000640SS
Firmware Revision  : 0003
Serial No          : 9XG05HG600009131MUVA
GUID               : 5000c50033e4b423
Protocol           : SAS
Drive Type         : SAS_HDD

```

Device is a Hard disk

```

Enclosure #           : 1
Slot #               : 1
SAS Address          : 5000c50-0-34d7-4269
State                : Optimal (OPT)
Size (in MB)/(in sectors) : 953869/1953525167
Manufacturer         : SEAGATE
Model Number        : ST91000640SS
Firmware Revision   : 0003
Serial No           : 9XG0N3ZJ00009202M9JV
GUID                : 5000c50034d7426b
Protocol            : SAS
Drive Type          : SAS_HDD

```

Device is a Hard disk

```

Enclosure #           : 1
Slot #               : 2
SAS Address          : 5000c50-0-33e6-0015
State                : Optimal (OPT)
Size (in MB)/(in sectors) : 953869/1953525167
Manufacturer         : SEAGATE
Model Number        : ST91000640SS
Firmware Revision   : 0003
Serial No           : 9XG05PBR00009131LUBB
GUID                : 5000c50033e60017
Protocol            : SAS
Drive Type          : SAS_HDD

```

Device is a Hard disk

```

Enclosure #           : 1
Slot #               : 4
SAS Address          : 5000c50-0-40c6-29d9
State                : Optimal (OPT)
Size (in MB)/(in sectors) : 953869/1953525167
Manufacturer         : SEAGATE
Model Number        : ST91000640SS
Firmware Revision   : 0003
Serial No           : 9XG0WHZB00009208GMC9
GUID                : 5000c50040c629db
Protocol            : SAS
Drive Type          : SAS_HDD

```

Device is a Hard disk

```

Enclosure #           : 1

```

```

Slot #                : 5
SAS Address           : 5000c50-0-34c2-72c5
State                 : Optimal (OPT)
Size (in MB)/(in sectors) : 953869/1953525167
Manufacturer          : SEAGATE
Model Number         : ST91000640SS
Firmware Revision    : 0003
Serial No            : 9XG0LFKM00009201LER8
GUID                 : 5000c50034c272c7
Protocol             : SAS
Drive Type           : SAS_HDD

```

Device is a Hard disk

```

Enclosure #          : 1
Slot #              : 6
SAS Address          : 5000c50-0-33e5-cbf1
State               : Optimal (OPT)
Size (in MB)/(in sectors) : 953869/1953525167
Manufacturer        : SEAGATE
Model Number       : ST91000640SS
Firmware Revision  : 0003
Serial No          : 9XG05KP800009119LZRZ
GUID              : 5000c50033e5cbf3
Protocol          : SAS
Drive Type        : SAS_HDD

```

-----  
Enclosure information  
-----

```

Enclosure#          : 1
Logical ID          : 50010f30:00002de0
Numslots           : 8
StartSlot          : 0

```

-----  
SAS2IRCU: Command DISPLAY Completed Successfully.

SAS2IRCU: Utility Completed Successfully.

- Run RAID consistency checks every month:

**NOTE:** You should run a consistency check on your JA2500 appliance at least once a month to make sure that grown drive defects are mapped out in case of a drive failure.



Do the following:

1. Log in to the appliance as the admin user.

The Junos Space Settings Menu appears.

2. Type 6, which is the (Debug) run shell option.

You are prompted to enter your password.

3. Type the password for the admin user and press Enter.

You are taken to the shell.

4. (Optional) If you do not have the volume ID of the RAID volume, run the following command:

```
[root@host ~]# sas2ircu 0 status
```

5. To start the consistency check, execute the following command, where *volume-id* refers to the ID of the RAID volume:

```
[root@host ~]# sas2ircu 0 constchk volume-id
```

6. Monitor the progress of the consistency check by executing the following command:

```
root@host # sas2ircu 0 status
```

If there is a problem found during the consistency check, the degraded state and the failed drive is displayed.

## Meaning

The outputs of the various commands provide information about the status of the RAID volume.

## RELATED DOCUMENTATION

---

[Maintaining the Junos Space Appliance | 178](#)

---

[Monitoring the Cooling Fans in a Junos Space Appliance | 183](#)

---

[Monitoring the Power Supply in a Junos Space Appliance | 186](#)

# Returning Hardware

## IN THIS CHAPTER

- Returning a JA2500 Junos Space Appliance or Component for Repair or Replacement | 194
- Locating the Serial Number on a JA2500 Junos Space Appliance or Component | 195
- Contacting Customer Support to Obtain Return Materials Authorization for Junos Space Appliances | 197
- Packing a JA2500 Junos Space Appliance or Component for Shipping | 199

## Returning a JA2500 Junos Space Appliance or Component for Repair or Replacement

If you need to return a JA2500 appliance or hardware component (field-replaceable unit [FRU]) to Juniper Networks for repair or replacement, do the following:

1. Determine the serial number of the appliance or component. For instructions, see "[Locating the Serial Number on a JA2500 Junos Space Appliance or Component](#)" on page 195.
2. Obtain a Return Materials Authorization (RMA) number from JTAC as described in "[Contacting Customer Support to Obtain Return Materials Authorization for Junos Space Appliances](#)" on page 197.

**NOTE:** Do not return any component to Juniper Networks unless you have first obtained an RMA number. Juniper Networks reserves the right to refuse shipments that do not have an RMA number. Refused shipments are returned to the customer through collect freight.

3. Pack the appliance or component for shipping as described in "[Packing a JA2500 Junos Space Appliance or Component for Shipping](#)" on page 199.

For more information about return and repair policies, see the customer support page at <http://www.juniper.net/support/guidelines.html>.

## RELATED DOCUMENTATION

[Field-Replaceable Units on the JA2500 Junos Space Appliance](#) | 3

[Unpacking the JA2500 Junos Space Appliance](#) | 82

## Locating the Serial Number on a JA2500 Junos Space Appliance or Component

### IN THIS SECTION

- [Listing the JA2500 Appliance Details using the Junos Space CLI](#) | 195
- [Locating the Chassis Serial Number ID Label on a JA2500 Appliance](#) | 196
- [Locating the Serial Number ID Labels on FRUs in the JA2500 Appliance](#) | 197

If you are returning a JA2500 Junos Space Appliance or hardware component to Juniper Networks for repair or replacement, you need to provide the serial number of the appliance or component to the Juniper Networks Technical Assistance Center (JTAC) when you contact them to obtain Return Materials Authorization (RMA) number. If the JA2500 appliance is operational and you can access the Junos Space CLI, you can list serial number of the appliance using a shell command. If you do not have access to the Junos Space CLI, you can find the serial number on the ID label present on the physical appliance or component.

**NOTE:** To find the serial number on the physical appliance component, you need to remove the component from the appliance chassis, for which you must have the required parts and tools available. See "[Installing and Removing JA2500 Junos Space Appliance Hardware Components](#)" on [page 161](#) for more information.

### Listing the JA2500 Appliance Details using the Junos Space CLI

Before you begin, ensure that you have connected the Junos Space appliance to a management console. For more information, refer to the "[Connecting a Junos Space Appliance to a Management Console](#)" on [page 94](#) topic.

To find the appliance serial number, do the following:

1. Log in to the appliance as the admin user.

The Junos Space Settings Menu appears.

2. Type 6, which is the (Debug) run shell option.

You are prompted to enter your password.

3. Type the password for the admin user and press Enter.

You are taken to the shell.

4. To view the information about the appliance, execute the following command:

```
[root@host ~]# dmidecode -t 1
```

The serial number is displayed in the output of the command, as shown in the following sample output.

```
# dmidecode 2.11
SMBIOS 2.7 present.
Handle 0x0001, DMI type 1, 27 bytes
System Information
    Manufacturer: Juniper Networks
    Product Name: JA2500
    Version: 1.0
    Serial Number: 0319082013000003
    UUID: 191A98D4-5E0D-11E3-AB3E-A82FF3456400
    Wake-up Type: Power Switch
    SKU Number: JA2500
    Family: Juniper Appliance
```

## Locating the Chassis Serial Number ID Label on a JA2500 Appliance

The serial number of a JA2500 appliance is displayed on the appliance chassis. To locate the serial number of the JA2500 appliance, see the label at the rear panel of the chassis, as shown in [Figure 26 on page 197](#).

Figure 26: Chassis Serial Number on the Rear Panel

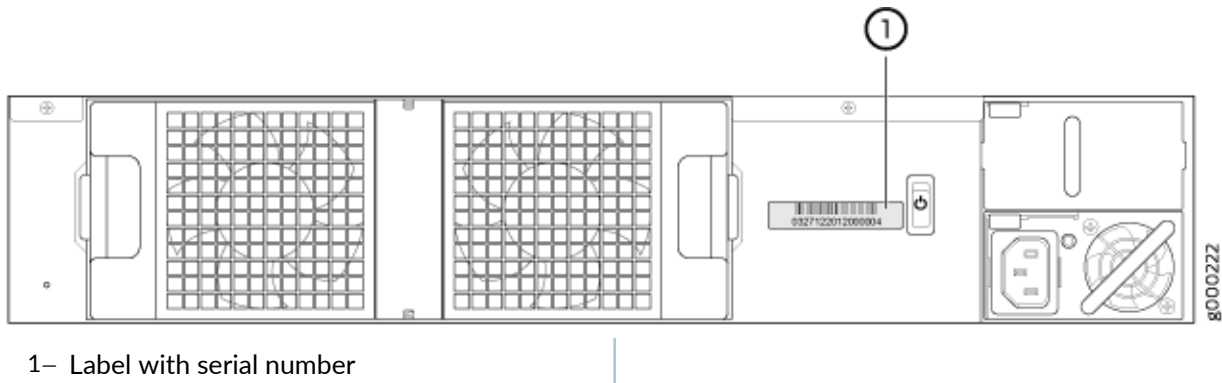

### Locating the Serial Number ID Labels on FRUs in the JA2500 Appliance

The cooling fans, hard disks, and power supply modules installed in the JA2500 appliance are field-replaceable units (FRUs). For each of these FRUs, you must remove the FRU from the appliance chassis to see the serial number ID label of the FRU.

- *AC Power Supply Module*—The serial number ID label is on the top of the AC power supply module.
- *Cooling Fan*—There is no serial number on the cooling fan; use the appliance serial number instead.
- *DC Power Supply Module*—The serial number ID label is on the top of the DC power supply module.
- *Hard Disks*—The serial number ID label is on the top of the hard disk.

### RELATED DOCUMENTATION

[Contacting Customer Support to Obtain Return Materials Authorization for Junos Space Appliances | 197](#)

[Packing a JA2500 Junos Space Appliance or Component for Shipping | 199](#)

## Contacting Customer Support to Obtain Return Materials Authorization for Junos Space Appliances

If you are returning a Junos Space Appliance or hardware component to Juniper Networks for repair or replacement, obtain a Return Materials Authorization (RMA) number from Juniper Networks Technical Assistance Center (JTAC).

After locating the serial number of the appliance or hardware component that you want to return, open a service request with JTAC through the Web or by telephone.

For instructions on locating the serial number of the appliance or hardware component you want to return, see "[Locating the Serial Number on a JA2500 Junos Space Appliance or Component](#)" on page 195.

Before you request an RMA number from JTAC, be prepared to provide the following information:

- Your existing service request number, if you have one
- Serial number of the appliance or component
- Your name, organization name, telephone number, fax number, and shipping address
- Details of the failure or problem
- Type of activity being performed on the appliance when the problem occurred

You can contact JTAC 24 hours a day, seven days a week through the Web or by telephone:

- Service Request Manager: <http://support.juniper.net/support/>
- Telephone: +1-888-314-5822, toll free in U.S., Canada, and Mexico

**NOTE:** For international or direct-dial options in countries without toll free numbers, see <https://support.juniper.net/support/>.

If you are contacting JTAC by telephone, enter your 12-digit service request number followed by the pound (#) key for an existing case, or press the star (\*) key to be routed to the next available support engineer.

The support engineer validates your request and issues an RMA number for the return of the component.

## RELATED DOCUMENTATION

[Locating the Serial Number on a JA2500 Junos Space Appliance or Component](#) | 195

[Packing a JA2500 Junos Space Appliance or Component for Shipping](#) | 199

## Packing a JA2500 Junos Space Appliance or Component for Shipping

### IN THIS SECTION

- [Packing a JA2500 Appliance for Shipping | 199](#)
- [Packing Components of the JA2500 Appliance for Shipping | 200](#)

If you are returning a JA2500 Junos Space Appliance or component (field-replaceable unit [FRU]) to Juniper Networks for repair or replacement, pack the item as described in this topic.

Before you begin packing the appliance or component, do the following:

- Obtain a Return Materials Authorization (RMA) number for the appliance or the component. For more information, see ["Contacting Customer Support to Obtain Return Materials Authorization for Junos Space Appliances" on page 197](#).
- Retrieve the original shipping carton and packing materials. Contact your JTAC representative if you do not have these materials, to learn about approved packing materials.
- Ensure that you understand how to prevent electrostatic discharge (ESD) damage. See ["Preventing Electrostatic Discharge Damage" on page 67](#).

### Packing a JA2500 Appliance for Shipping

Before you pack the JA2500 appliance, do the following:

1. Power off the appliance. Refer to the ["Powering Off the Junos Space Appliance" on page 148](#) topic for details.
2. Disconnect power from the appliance.
3. Remove the cables that connect the appliance to all external devices.

If you need to transport the JA2500 appliance to another location or return the appliance to Juniper Networks, you need to pack the appliance securely in its original packaging to prevent damage during transportation.

Ensure that you have the following parts and tools available to pack the appliance:

- Phillips (+) screwdriver, number 2
- ESD grounding strap

- Antistatic bag

To pack the JA2500 appliance, do the following:

1. If the appliance is installed in a rack, have one person support the weight of the appliance while another person unscrews and removes the mounting screws.
2. Remove the appliance from the rack and place the appliance on a flat, stable surface.
3. Use the screwdriver to remove the rack-mounting brackets from the appliance chassis.
4. Place the appliance in an antistatic bag.
5. Place the appliance inside the shipping carton.
6. Place packaging foam or a cardboard tray on top of and around the appliance to ensure adequate padding.
7. If you are returning accessories or field-replaceable units (FRUs) with the appliance, pack them as instructed in "[Packing Components of the JA2500 Appliance for Shipping](#)" on page 200.
8. Close the top of the cardboard carton and seal it with packing tape.
9. Write the RMA number on the exterior of the shipping carton to ensure proper tracking.

## Packing Components of the JA2500 Appliance for Shipping

Ensure that you have the following parts and tools available:

- Antistatic bags, one for each component
- ESD grounding strap

To pack the components (FRUs) of the JA2500 appliance, follow the instructions here.



**CAUTION:** Do not stack the components of the JA2500 appliance. Return individual components in separate boxes if you cannot pack them side by side in the shipping box.

To pack the components of the JA2500 appliance, do the following:

- Place individual components in antistatic bags.
- Use the original packing materials if they are available. If the original packing materials are not available, ensure that the component is adequately packed to prevent damage during transit. The packing material that you use must be able to support the weight of the component.
- Ensure that the components are adequately protected by wrapping them well with packing materials. Pack the component in an oversized box (if the original box is not available) with extra packing material around the unit so that the component is prevented from moving around inside the box.
- Securely tape the box closed.



- Write the RMA number on the exterior of the box to ensure proper tracking.

## RELATED DOCUMENTATION

[Contacting Customer Support to Obtain Return Materials Authorization for Junos Space Appliances | 197](#)

---

[Locating the Serial Number on a JA2500 Junos Space Appliance or Component | 195](#)