

JRR200 Route Reflector Hardware Guide

Published
2022-11-29

Juniper Networks, Inc.
1133 Innovation Way
Sunnyvale, California 94089
USA
408-745-2000
www.juniper.net

Juniper Networks, the Juniper Networks logo, Juniper, and Junos are registered trademarks of Juniper Networks, Inc. in the United States and other countries. All other trademarks, service marks, registered marks, or registered service marks are the property of their respective owners.

Juniper Networks assumes no responsibility for any inaccuracies in this document. Juniper Networks reserves the right to change, modify, transfer, or otherwise revise this publication without notice.

JRR200 Route Reflector Hardware Guide

Copyright © 2022 Juniper Networks, Inc. All rights reserved.

The information in this document is current as of the date on the title page.

YEAR 2000 NOTICE

Juniper Networks hardware and software products are Year 2000 compliant. Junos OS has no known time-related limitations through the year 2038. However, the NTP application is known to have some difficulty in the year 2036.

END USER LICENSE AGREEMENT

The Juniper Networks product that is the subject of this technical documentation consists of (or is intended for use with) Juniper Networks software. Use of such software is subject to the terms and conditions of the End User License Agreement ("EULA") posted at <https://support.juniper.net/support/eula/>. By downloading, installing or using such software, you agree to the terms and conditions of that EULA.

Table of Contents

About This Guide | viii

1

Overview

JRR200 Route Reflector Overview | 2

JRR200 Route Reflector System Overview | 2

JRR200 Route Reflector Field-Replaceable Units | 2

JRR200 Chassis | 3

JRR200 Route Reflector Chassis Front Panel | 3

JRR200 Route Reflector Chassis Rear Panel | 7

JRR200 Route Reflector Physical Specifications | 8

JRR200 Route Reflector Cooling System | 9

JRR200 Route Reflector Air Flow and Cooling System | 9

JRR200 Power System | 10

JRR200 Route Reflector AC Power Supply | 11

JRR200 Route Reflector AC Power Supply Specifications | 12

JRR200 Route Reflector AC Power Cord Specifications | 13

JRR200 Route Reflector DC Power Supply | 15

JRR200 Route Reflector DC Power Supply Specifications | 16

2

Site Planning, Preparation, and Specifications

Site Preparation Checklist for the JRR200 Route Reflector | 19

JRR200 Site Guidelines and Requirements | 20

JRR200 Route Reflector Environmental Specifications | 21

General Site Guidelines | 21

Site Electrical Wiring Guidelines | 22

Clearance Requirements for JRR200 Route Reflector Airflow and Hardware Maintenance | 23

JRR200 Rack and Cabinet Requirements | 24

JRR200 Route Reflector Rack Requirements | 24

JRR200 Route Reflector Cabinet Requirements | 25

JRR200 Network Cable and Transceiver Planning | 26

Pluggable Transceivers Supported on JRR200 Route Reflector | 27

SFP+ Direct Attach Copper Cables for JRR200 Route Reflector | 27

JRR200 Management and Console Port Connector Pinout Specifications | 28

Management Port Connector Pinout Information for the JRR200 Route Reflector | 28

Console Port Connector Pinout Information for the JRR200 Route Reflector | 29

3

Initial Installation and Configuration

JRR200 Route Reflector Installation Overview | 32

Installing and Connecting an JRR200 Route Reflector Installation Overview | 32

Unpacking the JRR200 | 33

Unpacking the JRR200 Route Reflector | 33

Verifying Parts Received with the JRR200 Route Reflector | 33

Installing the JRR200 Route Reflector in a Rack | 35

Connecting the JRR200 to Power | 38

Connect the Grounding Cable | 38

Connecting Power to an AC-Powered JRR200 Route Reflector | 39

Connecting Power to a DC-Powered JRR200 Route Reflector | 41

Connecting JRR200 Route Reflector to External Devices | 43

Connecting JRR200 Route Reflector to Management Devices | 43

Performing the Initial Configuration for JRR200 | 44

JRR200 Route Reflector Initial Configuration Using the CLI | 44

JRR200 Route Reflector Factory-Default Settings | 46

Viewing Factory-Default Settings of JRR200 Route Reflector | 48

4

Maintaining Components

Maintaining the JRR200 Chassis | 51

- Routine Maintenance Procedures for the JRR200 Route Reflector | 51

Maintaining the JRR200 Cooling System | 51

- Maintaining the Fan Trays on the JRR200 Route Reflector | 52

- Replacing the JRR200 Route Reflector Fan Tray | 53

Maintaining the JRR200 Power System | 54

- Maintaining the JRR200 Route Reflector Power Supplies | 54

- Replacing the JRR200 Route Reflector AC Power Supply | 55

 - Removing a JRR200 Route Reflector AC Power Supply | 56

 - Installing a JRR200 Route Reflector AC Power Supply | 57

- Replacing the JRR200 Route Reflector DC Power Supply | 58

 - Removing a JRR200 Route Reflector DC Power Supply | 58

 - Installing a JRR200 Route Reflector DC Power Supply | 59

Maintaining the JRR200 Cables and Connectors | 60

- Maintaining JRR200 Route Reflector Network Cables | 60

- Replacing an SFP+ Transceiver on JRR200 Route Reflector | 62

 - Removing an SFP+ Transceiver | 62

 - Installing an SFP+ Transceiver | 63

5

Troubleshooting Hardware

Troubleshooting the JRR200 | 66

- Troubleshooting Resources for JRR200 Route Reflector | 66

- Chassis Component Alarm Conditions on JRR200 Route Reflector | 66

6

Contacting Customer Support and Returning the Chassis or Components

Returning the JRR200 Chassis or Components | 72

- Returning a JRR200 Route Reflector or Hardware Component to Juniper Networks | 72

- Listing the JRR200 Route Reflector Component Details with the CLI | 73

- Locating the Serial Number on the JRR200 Route Reflector or Component | 74

 - Locating the Chassis Serial Number ID Label | 74

 - Locating the Serial Number ID Labels on FRUs | 74

Contacting Customer Support | 74

Packing a JRR200 Route Reflector or its Components for Shipping | 75

 Packing the JRR200 Route Reflector for Shipment | 76

 Packing the JRR200 Route Reflector Components for Shipment | 76

7

Safety and Compliance Information

General Safety Guidelines and Warnings | 80

Definitions of Safety Warning Levels | 81

Restricted Access Warning | 83

Fire Safety Requirements | 84

Qualified Personnel Warning | 85

Warning Statement for Norway and Sweden | 86

Installation Instructions Warning | 86

Chassis and Component Lifting Guidelines | 87

Ramp Warning | 88

Rack-Mounting and Cabinet-Mounting Warnings | 88

Grounded Equipment Warning | 92

Laser and LED Safety Guidelines and Warnings | 93

Radiation from Open Port Apertures Warning | 96

Maintenance and Operational Safety Guidelines and Warnings | 97

General Electrical Safety Guidelines and Warnings | 103

Prevention of Electrostatic Discharge Damage | 104

AC Power Electrical Safety Guidelines | 106

AC Power Disconnection Warning | 107

DC Power Disconnection Warning | 108

DC Power Grounding Requirements and Warning | 109

DC Power Wiring Sequence Warning | 110

DC Power Wiring Terminations Warning | 112

Multiple Power Supplies Disconnection Warning | 113

TN Power Warning | 114

Action to Take After an Electrical Accident | 114

JRR200 Agency Approvals and Regulatory Compliance Information | 115

Agency Approvals | 115

Acoustic Noise Compliance Statements | 117

EMC Requirements | 117

About This Guide

Use this guide to install hardware and perform initial software configuration, routine maintenance, and troubleshooting for the JRR200 Route Reflector.

After completing the installation and basic configuration procedures covered in this guide, refer to the Junos OS documentation for information about further software configuration.

RELATED DOCUMENTATION

| [JRR200 Route Reflector Quick Start](#)

1

CHAPTER

Overview

JRR200 Route Reflector Overview | 2

JRR200 Chassis | 3

JRR200 Route Reflector Cooling System | 9

JRR200 Power System | 10

JRR200 Route Reflector Overview

IN THIS SECTION

- [JRR200 Route Reflector System Overview | 2](#)
- [JRR200 Route Reflector Field-Replaceable Units | 2](#)

JRR200 Route Reflector System Overview

The Juniper Networks JRR200 Route Reflector is a 1U form factor appliance with a multicore x86 CPU and preinstalled vRR software that can host one route reflector instance. The JRR200 route reflector is suitable for large enterprises, data centers and service providers for hosting vRR software to scale up to 30 million routing information base (RIB) entries.

The JRR200 route reflector comes with eight 1/10 Gigabit Ethernet SFP+ ports, 64 GB of DDR4 memory, and two 240-GB solid-state drives (SSDs) in a RAID1 configuration. The JRR200 route reflector is available in both AC and DC models which support Zero Touch Provisioning mode (ZTP) to ensure seamless insertion into the network and provide operational simplicity.

- JRR200 Route Reflector (AC) – JRR200 Route Reflector with dual redundant AC power supplies
- JRR200 Route Reflector (DC) – JRR200 Route Reflector with dual redundant DC power supplies

JRR200 Route Reflector Field-Replaceable Units

Field-replaceable units (FRUs) are components that you can replace at your site. The FRUs on the JRR200 route reflector can be removed and replaced without powering off the route reflector. The JRR200 route reflector supports the following FRUs:

- AC power supply units
- DC power supply units
- Fan trays

JRR200 Chassis

IN THIS SECTION

- [JRR200 Route Reflector Chassis Front Panel | 3](#)
- [JRR200 Route Reflector Chassis Rear Panel | 7](#)
- [JRR200 Route Reflector Physical Specifications | 8](#)

JRR200 Route Reflector Chassis Front Panel

IN THIS SECTION

- [JRR200 Route Reflector Chassis Status LEDs | 4](#)
- [Management Port LEDs | 5](#)
- [Network Port LEDs | 6](#)

[Figure 1 on page 3](#) shows the front panel of the JRR200 route reflector.

Figure 1: JRR200 Route Reflector Front Panel

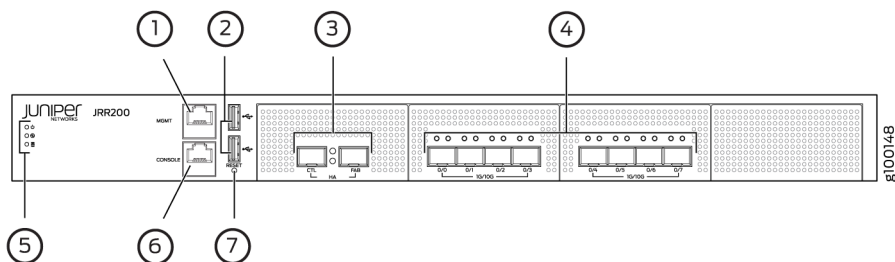

[Table 1 on page 4](#) lists the components on the front panel of the JRR200 route reflector.

Table 1: JRR200 Route Reflector Components on the Front Panel

Number	Component	Description
1	Management port	Gigabit Ethernet port to connect to the device over the network.
2	USB ports	Two USB 2.0 ports that accept a USB storage device.
3	HA ports	The two HA ports are not supported on the JRR200 route reflector.
4	SFP+ ports	Eight 1-Gigabit Ethernet/10-Gigabit Ethernet SFP+ ports for network traffic.
5	LEDs	Indicate component and system status at a glance.
6	Console port	Connects a laptop to the JRR200 route reflector for CLI management. The port uses an RJ-45 serial connection, is configured as DTE, and supports the RS-232 (EIA-232) standard.
7	RESET button	Returns the JRR200 route reflector to the factory-default configuration.

JRR200 Route Reflector Chassis Status LEDs

Figure 2 on page 4 shows the chassis status LEDs that are located on the front panel of the JRR200 route reflector. Table 2 on page 5 describes the LEDs.

Figure 2: JRR200 Route Reflector Chassis Status LEDs

Table 2: JRR200 Route Reflector Chassis Status LEDs

LED	Description
Power	<ul style="list-style-type: none"> • Solid green—receiving power
Status	<ul style="list-style-type: none"> • Solid green—operating normally • Solid red—critical alarm <ul style="list-style-type: none"> • Hardware component failure • Software module failure • Fan failure (atleast one) • Blinking red—noncritical alarm • Off—the system is not receiving power
SSD	<ul style="list-style-type: none"> • Blinking green—indicates hard disk drive (SSD) activity

Management Port LEDs

The management port has two LEDs that indicate link activity and status of the management port.

[Table 3 on page 5](#) describes the LEDs.

Table 3: Management Port LEDs

LED	Description
Link/Activity (LED on the left)	<ul style="list-style-type: none"> • Solid amber—A link is established, but there is no activity on the link. • Blinking amber—There is link activity. • Off—There is no link established.

Table 3: Management Port LEDs (Continued)

LED	Description
Speed (LED on the right)	<ul style="list-style-type: none"> • Solid green—100-Mbps link is established. • Solid amber—1000-Mbps link is established. • Off—There is no link established.

Network Port LEDs

Each SFP+ port has two status LEDs located above the port. [Table 4 on page 6](#) describes the LEDs. [Figure 3 on page 6](#) shows the LEDs.

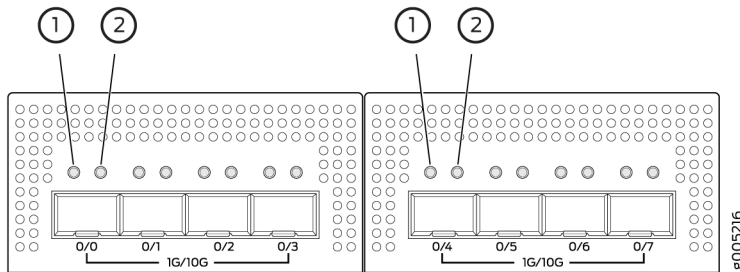
Figure 3: Network Port LEDs**Table 4: Network Port LEDs**

Callout	LED	Description
1	Link (LED on the left)	<ul style="list-style-type: none"> • Solid green—There is link activity. • Off—There is no link established.
2	Speed/Activity (LED on the right)	<ul style="list-style-type: none"> • Solid amber—10G/1G link is established. • Blinking amber—There is activity on the 10G/1G link. • Off—There is no link established.

JRR200 Route Reflector Chassis Rear Panel

Figure 4 on page 7 shows the rear panel of the JRR200 Route Reflector. Table 5 on page 7 lists and describes the rear panel components.

Figure 4: JRR200 Route Reflector Rear Panel

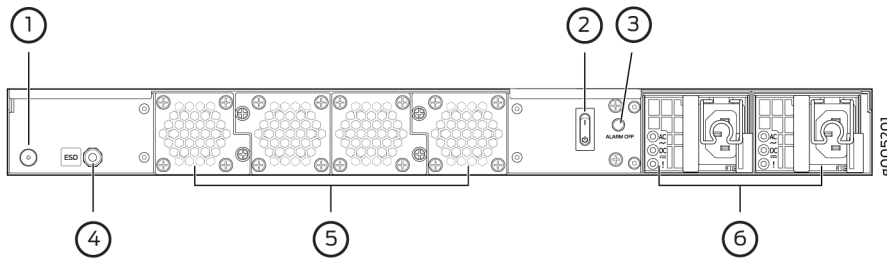

Table 5: JRR200 Route Reflector Rear Panel Components

Number	Component	Description
1	Grounding point	Connects the JRR200 route reflector chassis to earth ground.
2	Power switch	Use the Power switch to power on or power off the JRR200 route reflector.
3	Alarm Off button	Use this button to turn off an alarm triggered because of an abnormal DC output voltage caused by any of the following: <ul style="list-style-type: none"> • Only one power supply unit is plugged in. • The AC power cord is not plugged in. • The power supply unit is not functional and there is no DC output.
4	ESD point	For personal safety, while working on the JRR200 route reflector, use the ESD outlet to plug in an ESD grounding strap to prevent your body from sending static charges to the route reflector.

Table 5: JRR200 Route Reflector Rear Panel Components (Continued)

Number	Component	Description
5	Fan trays	Four fan trays for cooling the JRR200 route reflector and its components. Each fan tray contains two fans. Three fan trays are required for proper air flow across the chassis internal components. The fourth fan tray provides redundancy.
6	Power supply	Two power supply slots. Each power supply contains a power cord outlet. Two 650-W DC or AC power supplies are provided with the JRR200 route reflector.

JRR200 Route Reflector Physical Specifications

The JRR200 Route Reflector chassis is a rigid sheet metal structure that houses all the components. [Table 6 on page 8](#) lists the physical specifications of the chassis.

Table 6: Physical Specifications of the JRR200 Route Reflector Chassis

Description	Value
Chassis height	1.75 in. (4.45 cm)
Chassis width	17.48 in. (44.40 cm)
Chassis depth	25 in. (63.50 cm)
Weight	<ul style="list-style-type: none"> JRR200 route reflector with 2 AC power supplies: 29 lb (13.16 kg) JRR200 route reflector with 2 DC power supplies: 28.8 lb (13.06 kg)

You can mount the JRR200 route reflector on a standard 19-in. four-post rack or in a standard 19-in. enclosed cabinet.

JRR200 Route Reflector Cooling System

IN THIS SECTION

- [JRR200 Route Reflector Air Flow and Cooling System | 9](#)

JRR200 Route Reflector Air Flow and Cooling System

The cooling system for the JRR200 Route Reflector consists of four fan trays located at the rear of the chassis. Each fan tray contains two fans, so there are a total of eight fans. The fans draw cool air through vents on the front of the chassis and exhaust the air through the back of the chassis. See [Figure 5 on page 10](#). The airflow produced by the fans keeps device components within the acceptable temperature range.

If any one of the four fan trays fails, the JRR200 route reflector generates a warning but keeps the system running. If the temperature keeps rising, the JRR200 route reflector lowers the power consumption by reducing the performance or shutting down some of the chassis components. However, if the ambient maximum temperature exceeds the warning level and the system cannot be adequately cooled, then the JRR200 route reflector shuts down the system and hardware components completely.

The fan tray is a field-replaceable unit (FRU) and you can install it without powering off the JRR200 route reflector or disrupting the route reflector function.

Figure 5: Airflow Through the Chassis

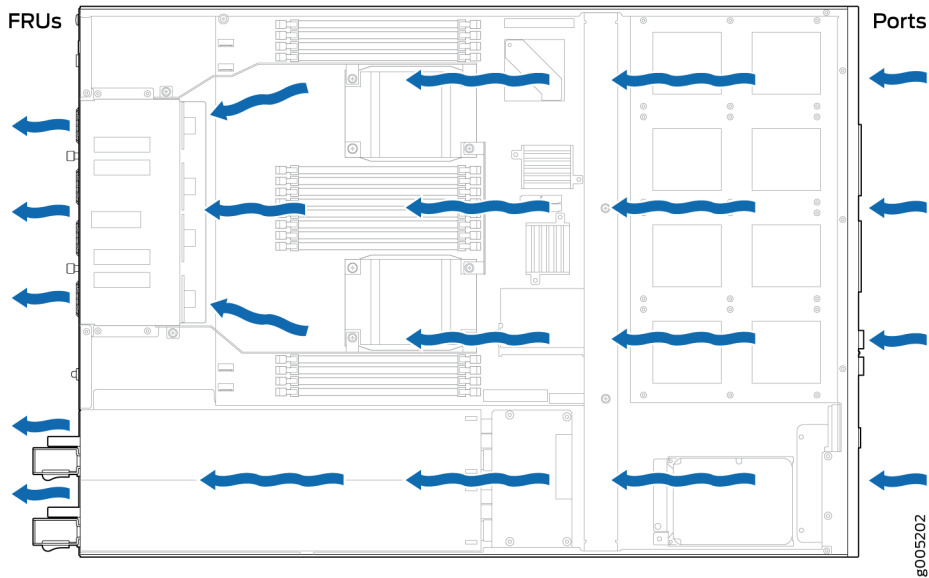

JRR200 Power System

IN THIS SECTION

- [JRR200 Route Reflector AC Power Supply | 11](#)
- [JRR200 Route Reflector AC Power Supply Specifications | 12](#)
- [JRR200 Route Reflector AC Power Cord Specifications | 13](#)
- [JRR200 Route Reflector DC Power Supply | 15](#)
- [JRR200 Route Reflector DC Power Supply Specifications | 16](#)

JRR200 Route Reflector AC Power Supply

The JRR200 Route Reflector is shipped with two redundant AC power supply units pre-installed in the rear panel of the chassis. The AC power supply unit is a field-replaceable unit (FRU) and you can install it without powering off the JRR200 route reflector or disrupting the route reflector function. If one power supply unit fails or is removed, the other power supply unit redistributes the electrical load without interruption. Each power supply unit is cooled by its own internal cooling system.

Each AC power supply unit weighs approximately 2.3 lb and consists of one AC appliance inlet, a fan, and LEDs for monitoring the status of the power supply unit. It gives an output of 650 W and supports both low line voltage (100–127 VAC) and high line voltage (200–240 VAC). [Figure 6 on page 11](#) shows the AC power supply unit.

Figure 6: AC Power Supply Unit

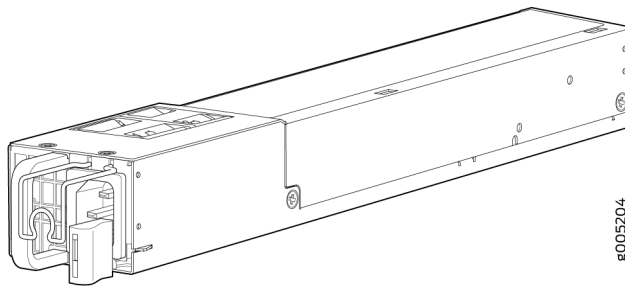

Each AC power supply unit faceplate contains three LEDs that indicate the status of the power supply. [Figure 7 on page 11](#) shows the location of the LEDs on an AC power supply unit.

Figure 7: AC Power Supply Unit LEDs

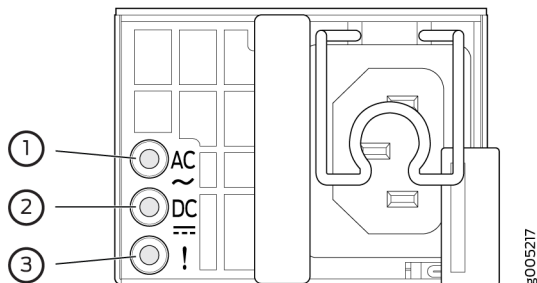

[Table 7 on page 12](#) describes the AC power supply unit LEDs.

Table 7: AC Power Supply Unit LEDs

LED	Color	State	Description
AC	Unlit	Off	Indicates one of the following: <ul style="list-style-type: none"> Power input voltage is not within the normal operating range. No power input.
	Green	Steady	Input power present and is within the normal operating range.
DC	Unlit	Off	No DC power output or abnormal DC output.
	Green	On steadily	DC power output is within the normal operating range.
! (Fault)	Amber	On steadily	Power supply unit failure.
		Blinking	Invalid power supply unit.
	Unlit	Off	Power supply unit is functioning normally.

NOTE:

- If both the AC LED and the DC LED are unlit, either the AC power cord is not installed properly or the power supply unit fuse has failed.
- If the AC LED is lit and the DC LED is unlit, the AC power supply unit is installed properly, but the power supply unit has an internal failure.

JRR200 Route Reflector AC Power Supply Specifications

Table 8 on page 13 lists the specifications for an AC power supply.

Table 8: AC Power Supply Specifications

Item	Specification
AC input voltage	Operating range: <ul style="list-style-type: none"> • Low-voltage line—100–127 VAC • High-voltage line—200–240 VAC
AC input line frequency	50–60 Hz
AC input current rating	<ul style="list-style-type: none"> • Low-voltage line—4 A • High-voltage line—2 A
AC output power	<ul style="list-style-type: none"> • Low-voltage line—650 W • High-voltage line—650 W
Maximum System Power Requirement	440 W
System Thermal Output = (Maximum System Power Requirement) * 3.41 Note: 1 W = 3.41 BTU/Hour	1500 BTU/Hour

JRR200 Route Reflector AC Power Cord Specifications

A detachable AC power cord is supplied with the AC power supplies. The coupler is type C13 as described by International Electrotechnical Commission (IEC) standard 60320.

NOTE: In North America, AC power cords must not exceed 4.5 m (approximately 14.75 ft) in length, to comply with National Electrical code (NEC) Section 400-8 (NFPA 75, 5-2.2) and 210-52, and Canadian Electrical Code (CEC) Section 4-010(3).

Table 9 on page 14 provides power cord specifications, and Figure 8 on page 14 depicts the plug on the AC power cord provided for each country or region.

Table 9: AC Power Cord Specifications

Country	Electrical Specification	Plug Standards
Australia	250 VAC, 10 A, 50 Hz	AS/NZ 3112-1993
China	250 VAC, 10 A, 50 Hz	GB2099.1 1996 and GB 1002 1996 (CH1-10P)
Europe (except Italy and United Kingdom)	250 VAC, 10 A, 50 Hz	CEE (7) VII
Italy	250 VAC, 10 A, 50 Hz	CEI 23-16/VII
Japan	125 VAC, 12 A, 50 or 60 Hz	JIS 8303
North America	125 VAC, 10 A, 60 Hz	NEMA 5-15
United Kingdom	250 VAC, 10 A, 50 Hz	BS 1363A

Figure 8: AC Plug Types



NOTE: Power cords and cables must not block access to the JRR200 route reflector components or drape where people might trip on them.



CAUTION: The AC power cord for the JRR200 route reflector is intended for use with the route reflector only and not for any other use.

JRR200 Route Reflector DC Power Supply

The JRR200 Route Reflector is shipped with two redundant DC power supply units pre-installed in the rear panel of the chassis. The DC power supply unit is a field-replaceable unit (FRU) and you can install it without powering off the JRR200 route reflector or disrupting the route reflector function. If one power supply unit fails or is removed, the other power supply unit redistributes the electrical load without interruption. Each power supply unit is cooled by its own internal cooling system.

Each DC power supply unit weighs approximately 2.2 lb and has two independent pairs of DC input lugs, a fan, and LEDs for monitoring the status of the power supply. It gives an output of 650 W. [Figure 9 on page 15](#) shows the DC power supply unit.

Figure 9: DC Power Supply Unit

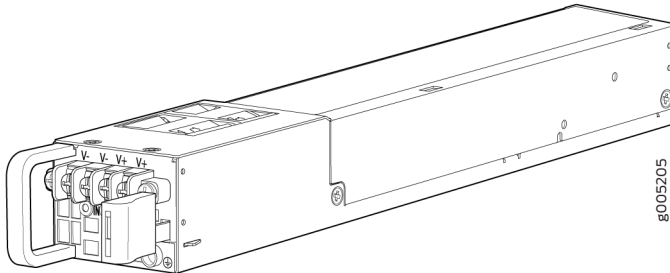

Each DC power supply unit faceplate contains three LEDs that indicate the status of the power supplies. [Figure 10 on page 15](#) shows the location of the LEDs on a DC power supply unit.

Figure 10: DC Power Supply LEDs

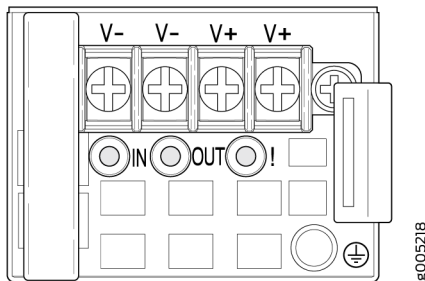

[Table 10 on page 16](#) describes the DC power supply unit LEDs.

Table 10: DC Power Supply unit LEDs

LED	Color	State	Description
IN	Unlit	Off	Indicates one of the following: <ul style="list-style-type: none"> • Power input voltage is not within the normal operating range. • No power input.
	Green	On steadily	Input power present and is within the normal operating range.
OUT	Unlit	Off	No DC power output or abnormal DC output.
	Green	On steadily	DC power output is within the normal operating range.
! (Fault)	Amber	On steadily	Power supply unit failure.
		Blinking	Invalid power supply unit.
	Unlit	Off	Power supply unit is functioning normally.

JRR200 Route Reflector DC Power Supply Specifications

[Table 11 on page 17](#) lists the power supply specifications for a DC power supply.

Table 11: DC Power Supply Specifications

Item	Specifications
DC input voltage	<ul style="list-style-type: none">• Minimum operating voltage: -40 VDC• Nominal operating voltage: -48 VDC• Operating voltage range: -40 VDC through -72 VDC
DC input current rating	9 A maximum at nominal operating voltage
Output power	650 W

2

CHAPTER

Site Planning, Preparation, and Specifications

Site Preparation Checklist for the JRR200 Route Reflector | 19

JRR200 Site Guidelines and Requirements | 20

JRR200 Rack and Cabinet Requirements | 24

JRR200 Network Cable and Transceiver Planning | 26

JRR200 Management and Console Port Connector Pinout Specifications | 28

Site Preparation Checklist for the JRR200 Route Reflector

Table 12 on page 19 provides a checklist of tasks you need to perform when preparing a site for installing the JRR200 Route Reflector.

Table 12: Site Preparation Checklist for JRR200 Route Reflector

Item or Task	Additional Information	Performed By	Date	Notes
<i>Power</i>				
Measure distance between external power sources and device installation site.				
Locate sites for connection of system grounding.				
Calculate the power consumption and requirements.	"JRR200 Power System" on page 10			
<i>Environment</i>				
Verify that environmental factors such as temperature and humidity do not exceed device tolerances.	"JRR200 Route Reflector Environmental Specifications" on page 21			
<i>Rack or Cabinet</i>				
Verify that your rack or cabinet meets the minimum requirements for the installation of the device.	"JRR200 Rack and Cabinet Requirements" on page 24			
Plan rack location, including required space clearances.				

Table 12: Site Preparation Checklist for JRR200 Route Reflector (Continued)

Item or Task	Additional Information	Performed By	Date	Notes
Secure the rack or cabinet to the floor and building structure.				
<i>Cables</i>				
Acquire cables and connectors: <ul style="list-style-type: none"> • Determine the number of cables needed based on your planned configuration. • Review the maximum distance allowed for each cable. Choose the length of cable based on the distance between the hardware components being connected. 				
Plan the cable routing and management.				

JRR200 Site Guidelines and Requirements

IN THIS SECTION

- [JRR200 Route Reflector Environmental Specifications | 21](#)
- [General Site Guidelines | 21](#)
- [Site Electrical Wiring Guidelines | 22](#)
- [Clearance Requirements for JRR200 Route Reflector Airflow and Hardware Maintenance | 23](#)

JRR200 Route Reflector Environmental Specifications

Table 13 on page 21 provides the required environmental conditions for normal JRR200 Route Reflector operations. In addition, the site must be as dust-free as possible because dust can clog air intake vents, reducing the efficiency of the cooling system.

Table 13: Environmental Specifications

Description	Value
Altitude	No performance degradation up to 6,562 feet (2000 meters).
Relative humidity	Normal operation ensured in relative humidity range of 5% through 90%, non-condensing.
Temperature	<ul style="list-style-type: none"> • Normal operation ensured in temperature range of 32° F through 104° F (0° C through 40° C). • Non-operating storage temperature in shipping container: -40° F through 158° F (-40° C through 70° C).

General Site Guidelines

Efficient device operation requires proper site planning and maintenance. It also requires proper layout of the equipment, rack or cabinet, and wiring closet.

To plan and create an acceptable operating environment for your device and prevent environmentally caused equipment failures:

- Keep the area around the chassis free from dust and conductive material, such as metal flakes.
- Follow prescribed airflow guidelines to ensure that the cooling system functions properly. Ensure that exhaust from other equipment does not blow into the intake vents of the device.
- Follow the prescribed electrostatic discharge (ESD) prevention procedures to prevent damaging the equipment. Static discharge can cause components to fail completely or intermittently over time.
- Install the device in a secure area, so that only authorized personnel can access the device.

Site Electrical Wiring Guidelines

Table 14 on page 22 describes the factors you must consider while planning the electrical wiring at your site.



WARNING: You must provide a properly grounded and shielded environment and use electrical surge-suppression devices.

Avertissement Vous devez établir un environnement protégé et convenablement mis à la terre et utiliser des dispositifs de parasurtension.

Table 14: Site Electrical Wiring Guidelines

Site Wiring Factor	Guidelines
Signaling limitations	<p>If your site experiences any of the following problems, consult experts in electrical surge suppression and shielding:</p> <ul style="list-style-type: none"> • Improperly installed wires cause radio frequency interference (RFI). • Damage from lightning strikes occurs when wires exceed recommended distances or pass between buildings. • Electromagnetic pulses (EMPs) caused by lightning damage unshielded conductors and electronic devices.
Radio frequency interference	<p>To reduce or eliminate RFI from your site wiring, do the following:</p> <ul style="list-style-type: none"> • Use a twisted-pair cable with a good distribution of grounding conductors. • If you must exceed the recommended distances, use a high-quality twisted-pair cable with one ground conductor for each data signal, when applicable.
Electromagnetic compatibility	<p>If your site is susceptible to problems with electromagnetic compatibility (EMC), particularly from lightning or radio transmitters, seek expert advice.</p> <p>Strong sources of electromagnetic interference (EMI) can cause:</p> <ul style="list-style-type: none"> • Destruction of the signal drivers and receivers in the device, • Electrical hazards as a result of power surges conducted over the lines into the equipment.

Clearance Requirements for JRR200 Route Reflector Airflow and Hardware Maintenance

When planning the installation site, you need to allow sufficient clearance around the JRR200 Route Reflector. Consider the following:

- For the cooling system to function properly, the airflow around the chassis must be unrestricted. See [Figure 11 on page 23](#).

Figure 11: Airflow Through the Chassis

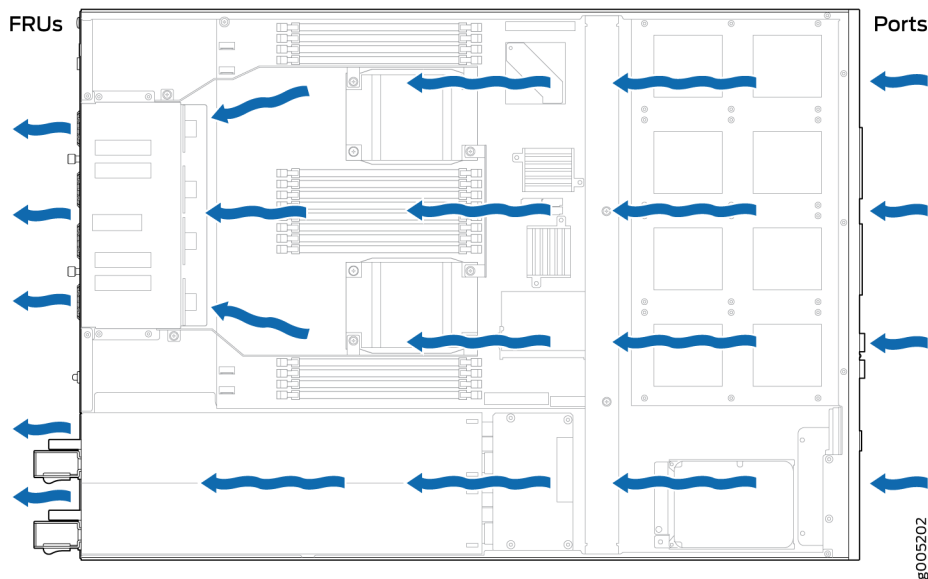

- If you are mounting the JRR200 route reflector on a rack or cabinet along with other equipment, ensure that the exhaust from other equipment does not blow into the intake vents of the chassis.
- For service personnel to remove and install hardware components, there must be adequate space at the front and back of the JRR200 route reflector as indicated in [Table 15 on page 24](#).

[Table 15 on page 24](#) provides information about the clearance requirements for maintaining optimum airflow and the distances necessary to facilitate easy maintenance of the JRR200 route reflector.

Table 15: Clearance Requirements for the JRR200 Route Reflector

Location	Recommended Clearance	Requirement for Clearance
Front of the chassis	34.25 in. (87 cm)	Space for service personnel to remove and install hardware components
Rear of the chassis	17.4 in. (44.2 cm)	Space for service personnel to remove and install hardware components
Between front-mounting flange and rack or cabinet edge	2.5 in. (6.35 cm)	Space for cable management and organization
Between both sides of the chassis and any non-heat-producing surface such as a wall or cabinet side	6.0 in. (15.24 cm)	Space for the cooling system to function properly and to maintain unrestricted airflow around the chassis

JRR200 Rack and Cabinet Requirements

IN THIS SECTION

- [JRR200 Route Reflector Rack Requirements | 24](#)
- [JRR200 Route Reflector Cabinet Requirements | 25](#)

JRR200 Route Reflector Rack Requirements

The JRR200 Route Reflector is designed to be installed on four-post racks. [Table 16 on page 25](#) provides the rack requirements and specifications for the route reflector.

Table 16: Rack Requirements

Rack Requirement	Guidelines
Rack type	<p>Use a four-post rack that provides bracket holes or hole patterns spaced at 1 U (1.75 in. or 4.45 cm) increments and that meets the size and strength requirements to support the weight.</p> <p>A U is the standard rack unit defined in Cabinets, Racks, Panels, and Associated Equipment (document number EIA-310-D) published by the Electronics Industry Association (http://www.eia.org).</p>
Mounting bracket hole spacing	<p>The holes in the mounting brackets are spaced at 1 U (1.75 in. or 4.45 cm), so that the device can be mounted in any rack that provides holes spaced at that distance.</p>
Rack size and strength	<ul style="list-style-type: none"> • Ensure that the rack complies with the size and strength standards of a 19-in. rack as defined in Cabinets, Racks, Panels, and Associated Equipment (document number EIA-310-D) published by the Electronics Industry Association (http://www.eia.org). • The rack must be strong enough to support the weight of the JRR200 route reflector. • Ensure that the spacing of rails and adjacent racks provides for proper clearance around the JRR200 route reflector and rack.
Rack connection to building structure	<ul style="list-style-type: none"> • Secure the rack to the building structure. • If earthquakes are a possibility in your geographical area, secure the rack to the floor. • Secure the rack to the ceiling brackets as well for maximum stability.

JRR200 Route Reflector Cabinet Requirements

You can install the JRR200 Route Reflector in a 19 in. (48.7 cm) cabinet. [Table 17 on page 26](#) provides the cabinet requirements and specifications.

Table 17: Cabinet Requirements and Specifications

Cabinet Requirement	Guideline
Cabinet size	You can mount the JRR200 route reflector in a cabinet that contains a 19-in. rack as defined in Cabinets, Racks, Panels, and Associated Equipment (document number EIA-310-D) published by the Electronics Industry Association (http://www.ecianow.org/standards-practices/standards/).
Cabinet clearance	<ul style="list-style-type: none"> • The outer edges of the mounting brackets extend the width of the chassis to 19 in. (48.2 cm). • The minimum total clearance inside the cabinet is 30 in. (76.2 cm) between the inside of the front door and the inside of the rear door.
Cabinet airflow requirements	<p>When you mount JRR200 route reflector in a cabinet, you must ensure that ventilation through the cabinet is sufficient to prevent overheating.</p> <ul style="list-style-type: none"> • Install the JRR200 route reflector as close as possible to the front of the cabinet so that the cable management system clears the inside of the front door. Installing the chassis close to the front of the cabinet maximizes the clearance in the rear of the cabinet for critical airflow. • Ensure adequate cool air supply to dissipate the thermal output of the JRR200 route reflector. • Route and dress all cables to minimize the blockage of airflow to and from the chassis. • A cabinet larger than the minimum required provides better airflow and reduces the chance of overheating.

JRR200 Network Cable and Transceiver Planning

IN THIS SECTION

- [Pluggable Transceivers Supported on JRR200 Route Reflector | 27](#)

- SFP+ Direct Attach Copper Cables for JRR200 Route Reflector | 27

Pluggable Transceivers Supported on JRR200 Route Reflector

The ports on the JRR200 Route Reflector supports SFP+ transceivers. You can find the list of transceivers supported on JRR200 route reflector and information about those transceivers at the [The Hardware Compatibility Tool](#).

NOTE: We recommend that you use only optical transceivers and optical connectors purchased from Juniper Networks with your Juniper Networks device.



CAUTION: The Juniper Networks Technical Assistance Center (JTAC) provides complete support for Juniper-supplied optical modules and cables. However, JTAC does not provide support for third-party optical modules and cables that are not qualified or supplied by Juniper Networks. If you face a problem running a Juniper device that uses third-party optical modules or cables, JTAC may help you diagnose host-related issues if the observed issue is not, in the opinion of JTAC, related to the use of the third-party optical modules or cables. Your JTAC engineer will likely request that you check the third-party optical module or cable and, if required, replace it with an equivalent Juniper-qualified component.

Use of third-party optical modules with high-power consumption (for example, coherent ZR or ZR+) can potentially cause thermal damage to or reduce the lifespan of the host equipment. Any damage to the host equipment due to the use of third-party optical modules or cables is the users' responsibility. Juniper Networks will accept no liability for any damage caused due to such use.

SFP+ Direct Attach Copper Cables for JRR200 Route Reflector

Small form-factor pluggable plus transceiver (SFP+) direct attach copper (DAC) cables are suitable for short distances of up to 23 ft (7 m), making them ideal for highly cost-effective networking connectivity within a rack and between adjacent racks. The JRR200 Route Reflector supports the following 1 m and 3 m long DAC cables:

- SRX-SFP-10GE-DAC-1M

- SRX-SFP-10GE-DAC-3M

For the full specifications of these transceivers, see [The Hardware Compatibility Tool](#).

JRR200 Management and Console Port Connector Pinout Specifications

IN THIS SECTION

- [Management Port Connector Pinout Information for the JRR200 Route Reflector | 28](#)
- [Console Port Connector Pinout Information for the JRR200 Route Reflector | 29](#)

Management Port Connector Pinout Information for the JRR200 Route Reflector

The port on the front panel labeled **MGMT** is an autosensing 10/100/1000-Mbps Ethernet RJ-45 receptacle that accepts an Ethernet cable for connecting the JRR200 Route Reflector to a management LAN (or other device that supports out-of-band management). Two LEDs on the port indicate link activity on the port and the administrative status of the port.

[Table 18 on page 28](#) provides the pinout information for the RJ-45 connector for the management port. An RJ-45 cable, with a connector attached, is supplied with the JRR200 route reflector.

Table 18: Management Port Connector Pinout Information

Pin	Signal
1	TX+
2	TX-
3	RX+

Table 18: Management Port Connector Pinout Information (Continued)

Pin	Signal
4	Termination network
5	Termination network
6	RX-
7	Termination network
8	Termination network

Console Port Connector Pinout Information for the JRR200 Route Reflector

The console port is an RS-232 serial interface that uses an RJ-45 connector to connect to a console management device. The default baud rate for the console port is 9600 baud.

[Table 19 on page 29](#) provides the pinout information for the RJ-45 console connector. An Ethernet cable that has an RJ-45 connector at either end and an RJ-45 to DB-9 serial port adapter are supplied with the route reflector.

Table 19: Console Port Connector Pinout Information

Pin	Signal	Description
1	RTS	Request to Send
2	DTR	Data Terminal Ready
3	TXD	Transmit Data

Table 19: Console Port Connector Pinout Information (Continued)

Pin	Signal	Description
4	Ground	Signal Ground
5	Ground	Signal Ground
6	RXD	Receive Data
7	DSR/DCD	Data Set Ready
8	CTS	Clear to Send

3

CHAPTER

Initial Installation and Configuration

[JRR200 Route Reflector Installation Overview | 32](#)

[Unpacking the JRR200 | 33](#)

[Installing the JRR200 Route Reflector in a Rack | 35](#)

[Connecting the JRR200 to Power | 38](#)

[Connecting JRR200 Route Reflector to External Devices | 43](#)

[Performing the Initial Configuration for JRR200 | 44](#)

JRR200 Route Reflector Installation Overview

IN THIS SECTION

- [Installing and Connecting an JRR200 Route Reflector Installation Overview](#) | 32

Installing and Connecting an JRR200 Route Reflector Installation Overview

To install and connect a JRR200 Route Reflector:

1. Follow instructions in ["Unpacking the JRR200"](#) on page 33.
2. Install power supplies if they are not pre-installed. See:
 - ["Installing a JRR200 Route Reflector AC Power Supply"](#) on page 55
 - ["Installing a JRR200 Route Reflector DC Power Supply"](#) on page 58
3. Mount the JRR200 Route Reflector as described in ["Installing the JRR200 Route Reflector in a Rack"](#) on page 35.
4. Connect the grounding cable as described in ["Connect the Grounding Cable"](#) on page 38.
5. Follow instructions for connecting power as appropriate for your site. See:
 - ["Connecting Power to an AC-Powered JRR200 Route Reflector"](#) on page 39
 - ["Connecting Power to a DC-Powered JRR200 Route Reflector"](#) on page 41
6. Connect the JRR200 route reflector to external devices as described in ["Connecting JRR200 Route Reflector to External Devices"](#) on page 43.
7. Perform initial configuration by following the instructions in ["Performing the Initial Configuration for JRR200"](#) on page 44.

Unpacking the JRR200

IN THIS SECTION

- [Unpacking the JRR200 Route Reflector | 33](#)
- [Verifying Parts Received with the JRR200 Route Reflector | 33](#)

Unpacking the JRR200 Route Reflector

The JRR200 Route Reflector is shipped in a cardboard carton, secured with foam packing material. The carton also contains an accessory box and quick-start instructions.



CAUTION: The JRR200 route reflector is maximally protected inside the cardboard carton. Do not unpack it until you are ready to begin installation.

To unpack the JRR200 route reflector:

1. Move the cardboard carton to a staging area as close to the installation site as possible, where you have enough room to remove the components from the chassis.
2. Open the carton.
3. Pull out the packing material holding the JRR200 route reflector in place.
4. Verify the parts received against the inventory (packing list). The packing list specifies the part numbers and carries a brief description of each part in your order.
5. Save the shipping carton and packing materials in case you need to move or ship the JRR200 route reflector at a later time.

Verifying Parts Received with the JRR200 Route Reflector

A packing list is included in each shipment. Check the parts in the shipment against the items on the packing list. The packing list specifies the part numbers and descriptions of each part in your order.

If any part on the packing list is missing, contact your customer service representative or contact Juniper customer care from within the U.S. or Canada by telephone at 1-888-314-5822. For international-dial or

direct-dial options in countries without toll-free numbers, see <https://www.juniper.net/support/requesting-support.html> .

NOTE: The parts shipped with your JRR200 route reflector can vary depending on the configuration you ordered.

Table 20 on page 34 lists the parts and their quantities in the packing list.

Table 20: Parts List for a Fully Configured JRR200 Route Reflector

Component	Quantity
Route reflector	1
Power supply (pre-installed)	2 AC or DC
AC power cord appropriate for your geographical location (only for AC models)	2
Rack mount kit	1
Quick Start installation instructions	1
Juniper Product ROHS and Warranty Document	1
End User License Agreement	1
Safety Guide	1
RJ-45 to DB-9 serial port adapter	1
RJ-45 cables	2

Installing the JRR200 Route Reflector in a Rack

You can mount the route reflector on four posts in a 19-in. rack or cabinet by using the rack-mount kit shipped with the device. (The remainder of this topic uses rack to mean rack or cabinet.)

Before mounting the JRR200 route reflector on four posts in a rack:

1. Verify that the site meets the requirements described in "[Site Preparation Checklist for the JRR200 Route Reflector](#)" on page 19.
2. Place the rack or cabinet in its permanent location, allowing adequate clearance for airflow and maintenance, and secure it to the building structure.
3. Verify that the rack or cabinet meets the specific requirements described in "[JRR200 Rack and Cabinet Requirements](#)" on page 24.
4. Remove the JRR200 route reflector from the shipping carton (see "[Unpacking the JRR200](#)" on page 33).

Ensure that you have the following parts and tools available:

- Electrostatic discharge (ESD) grounding strap
- Screws to secure the mounting brackets to the chassis
- Rack-mounting screws to secure the chassis to the four rack posts—not provided
- Phillips (+) screwdriver, number 2
- Two persons are required for mounting the JRR200 route reflector.

NOTE:

- Ensure that the rack is in its permanent location, allowing adequate clearance for airflow and maintenance, and secured to the building structure.
- If you are mounting multiple units in the rack, mount the heaviest unit at the bottom and mount the others from bottom to top in order of decreasing weight.



CAUTION: Wrap and fasten one end of the ESD grounding strap around your wrist and connect the other end to a site ESD point.

NOTE: Ensure that the rear of the JRR200 route reflector is supported throughout the process of mounting the route reflector into the rack.

To mount the JRR200 route reflector on a four-post rack:

1. Attach the front-mounting brackets and the side mounting rails to the chassis by using the flat-head screws.

Figure 12: Attaching the Mounting Ears and Fixed Brackets

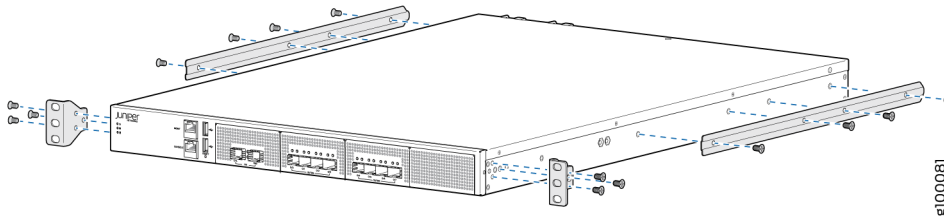

NOTE: Ensure that the rear of the device is supported throughout the process of mounting the device into the rack.

2. Have one person grasp both sides of the JRR200 route reflector, lift it, and position it in the rack so that the front mounting bracket holes align with the threaded holes in the rack rail and the second

person secure the front of the JRR200 route reflector to the rack by using rack-mounting screws (and cage nuts and washers if your rack requires them).

Figure 13: Securing the Mounting Ears to the Rack

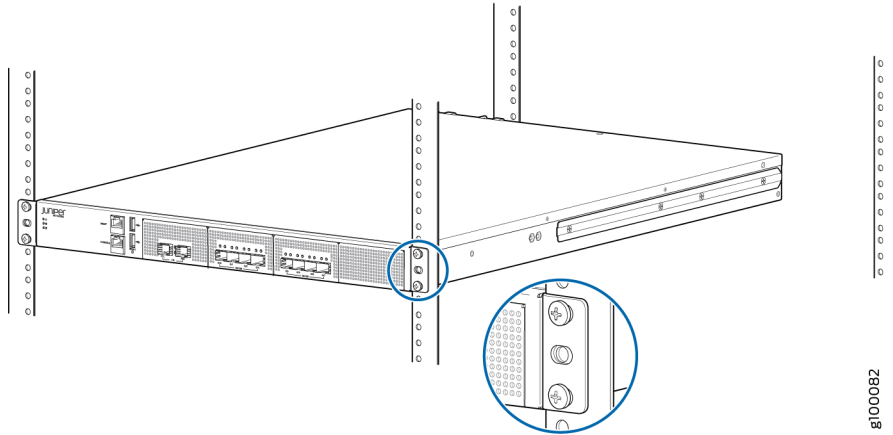

3. Continue to support the JRR200 route reflector, and have the second person slide the rear mounting blades into the channels of the side mounting rails and secure the blades to the rack. Use rack-mounting screws (and cage nuts and washers if your rack requires them) to attach the sliding blades to the rack.

Figure 14: Attaching the Adjustable Brackets

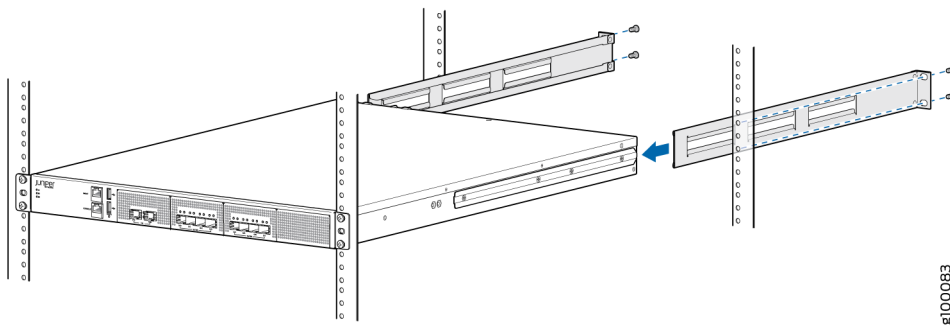

Connecting the JRR200 to Power

IN THIS SECTION

- [Connect the Grounding Cable | 38](#)
- [Connecting Power to an AC-Powered JRR200 Route Reflector | 39](#)
- [Connecting Power to a DC-Powered JRR200 Route Reflector | 41](#)

Connect the Grounding Cable

Ensure that you have the following parts and tools available:

- Electrostatic discharge (ESD) grounding wrist strap
- Phillips (+) screwdriver, number 2
- 16 AWG single-strand wire grounding cable (green and yellow wire)
- Grounding lug (ring-type, vinyl-insulated TV14-6R lug, or equivalent)
- One metric M5 x 10 mm grounding screw

To meet safety and electromagnetic interference (EMI) requirements and to ensure proper operation, the JRR200 Route Reflector must be adequately grounded before power is connected. You must provide a grounding lug to connect the route reflector to earth ground.

You ground the route reflector by connecting a grounding cable to earth ground and then attaching it to the chassis grounding point located on the back panel of the device using an M5 x 10 mm grounding screw.



CAUTION: Before you connect power to the route reflector, a licensed electrician must attach a cable lug to the grounding cable that you supply. A cable with an incorrectly attached lug can damage the route reflector (for example, by causing a short circuit).

To connect the route reflector to earth ground:

1. Attach an electrostatic discharge (ESD) grounding strap to your bare wrist, and connect the strap to an approved site ESD grounding point. See the instructions for your site.

2. Connect one end of the grounding cable to a proper earth ground, such as the rack in which the JRR200 route reflector is mounted.
3. Place the grounding cable lug over the grounding point on the rear of the chassis.

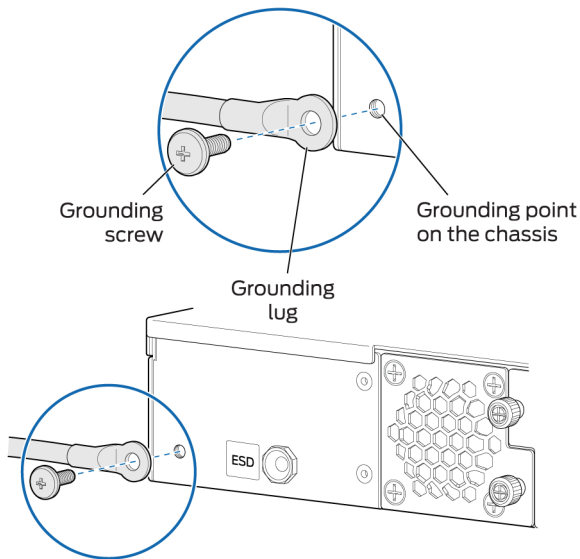

NOTE: The JRR200 route reflector should be permanently connected to ground during normal operation. A licensed electrician must attach a cable lug to the grounding cable. A cable with an incorrectly attached lug can damage the JRR200 route reflector.

4. Secure the grounding cable lug to the grounding point with the screw.
5. Dress the grounding cable and ensure that it does not touch or block access to other device components and that it does not drape where people could trip over it.

NOTE: When removing the chassis, turn off the power, and disconnect the grounding cable.

Connecting Power to an AC-Powered JRR200 Route Reflector

Ensure that you have a power cord appropriate for your geographical location available to connect AC power to the JRR200 Route Reflector. Before you begin connecting AC power:

- Ensure that you have taken the necessary precautions to prevent electrostatic discharge (ESD) damage.
- Ensure that you have connected the device chassis to earth ground.



CAUTION: Before you connect power to the JRR200 route reflector, a licensed electrician must attach a cable lug to the grounding cable that you supply. A cable with an incorrectly attached lug can damage the device (for example, by causing a short circuit).

To meet safety and electromagnetic interference (EMI) requirements and to ensure proper operation, you must properly ground the JRR200 route reflector chassis before connecting power.

- Check that the power supplies are fully inserted into the chassis.

To connect AC power:

1. Attach an electrostatic discharge (ESD) grounding strap to your bare wrist, and connect the strap to the ESD point on the rear of the chassis.
2. Locate the power cords shipped with the JRR200 route reflector; the cords have plugs appropriate for your geographical location.
3. Set the power switch on the JRR200 route reflector to the off (O) position.
4. Insert the coupler end of the power cord into the AC power cord inlet on the AC power supply faceplate. Push the power cord retainer onto the power cord.

NOTE: An AC-powered device gets additional grounding when you connect the power supply in the device to a grounded AC power outlet by using the power cord.

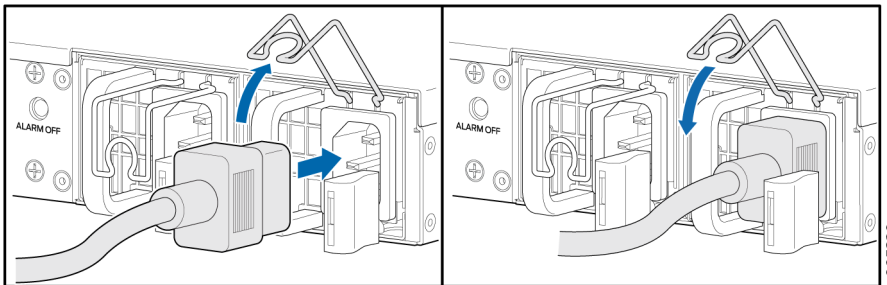

5. Insert the power cord plug into an AC power source outlet.
6. Repeat steps 4 and 5 for the second AC power supply.
7. Dress the power cord appropriately. Verify that the power cord does not block the air exhaust and access to JRR200 route reflector components or drape where people could trip on it.
8.
 - If the AC power source outlet has a power switch, set it to on (I) position. Set the power switch on the JRR200 route reflector to the on (I) position and it will power on.

- If there is no power switch on the AC power source outlet, set the power switch on the JRR200 route reflector to the on (I) position and it will power on.

9. Verify that the **AC** and **DC** LEDs on each power supply are lit green.

Connecting Power to a DC-Powered JRR200 Route Reflector

Before you begin connecting DC power to a JRR200 Route Reflector:

- Ensure that you have taken the necessary precautions to prevent electrostatic discharge (ESD) damage.
- Ensure that you have connected the chassis to earth ground.



CAUTION: Before you connect power to the JRR200 route reflector, a licensed electrician must attach a cable lug to the grounding cable that you supply. A cable with an incorrectly attached lug can damage the device (for example, by causing a short circuit).

To meet safety and electromagnetic interference (EMI) requirements and to ensure proper operation, you must properly ground the JRR200 route reflector chassis before connecting power.

- Check that the power supplies are fully inserted into the chassis.

Ensure that you have the following parts and tools available:

- DC power source cables (14–16 AWG) with ring lug
- Phillips (+) screwdriver, number 2
- Multimeter

To connect DC power:



WARNING: Before performing the following procedure, ensure that there is no power in the DC circuit. To ensure that all power is cut off, locate the circuit breaker on the panel board that services the DC circuit, switch the circuit breaker to the off (O) position, and tape the switch handle of the circuit breaker in the off position.

1. Attach an electrostatic discharge (ESD) grounding strap to your bare wrist, and connect the strap to the ESD point on the rear of the chassis.

2. Ensure that the voltage across the DC power source cable leads is 0 V and that the cable leads do not become active while you are connecting DC power.
3. Verify that the DC power cables are correctly labeled before making connections to the power supply. In a typical power distribution scheme where the return is connected to chassis ground at the battery plant, you can use a multimeter to verify the resistance of the -48V and RTN DC cables to chassis ground.
 - The cable with very high resistance (indicating an open circuit) to chassis ground is negative (-) and will be installed on the **V-** (input) DC power input terminal.
 - The cable with very low resistance (indicating a closed circuit) to chassis ground is positive (+) and will be installed on the **V+** (return) DC power input terminal.



CAUTION: You must ensure that power connections maintain the proper polarity. The power source cables might be labeled (+) and (-) to indicate their polarity. There is no standard color coding for DC power cables. The color coding used by the external DC power source at your site determines the color coding for the leads on the power cables that attach to the terminal studs on each power supply.

4. Remove the protective cover from the terminal studs on the faceplate. Save this cover for future use.
5. Remove the screws on the terminals by using a number 2 Phillips (+) screwdriver.
6. Secure each positive (+) DC source power cable lug to a RTN (return) terminal. Secure each negative (-) DC source power cable lug to a -48 V (input) terminal.
7. Tighten the screws on the power supply terminals until snug using the screwdriver. Do not overtighten.

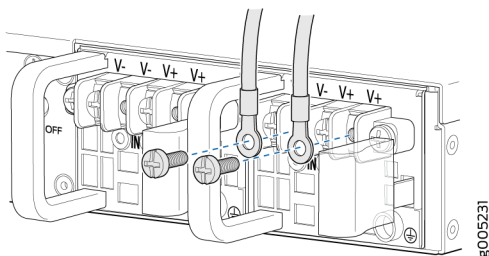

8. Replace the protective cover over the terminal studs on the faceplate.
9. Switch the circuit breaker to the ON (I) position.
10. Verify that the **IN** and **OUT** LEDs on the power supply are lit green and are on steadily.

Connecting JRR200 Route Reflector to External Devices

IN THIS SECTION

- [Connecting JRR200 Route Reflector to Management Devices | 43](#)

Connecting JRR200 Route Reflector to Management Devices

To configure the JRR200 route reflector, you must connect a management device to the **CONSOLE** port located on the front panel of the JRR200 route reflector, using the provided RJ-45-to-DB-9 adapter and the RJ45 cable.

1. Attach an electrostatic discharge (ESD) grounding strap to your bare wrist, and connect the strap to the ESD point on the chassis.
2. Plug one end of the RJ-45 cable into the **CONSOLE** port of the JRR200 route reflector and the other end into the DB-9 serial port adapter.

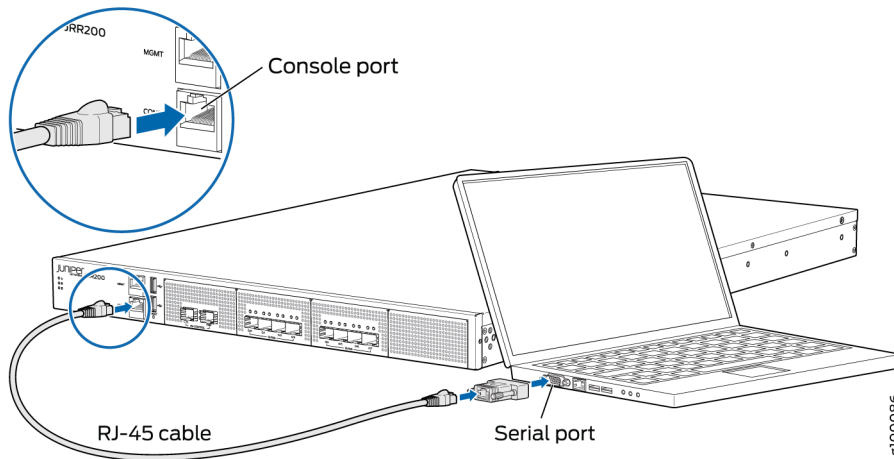

3. Connect the DB-9 serial port adapter end of the RJ-45 cable to the serial port of your management device. Use the following values to configure the serial port:
 - Baud rate—9600
 - Parity—N

- Data bits—8
- Stop bits—1
- Flow control—None

Performing the Initial Configuration for JRR200

IN THIS SECTION

- [JRR200 Route Reflector Initial Configuration Using the CLI | 44](#)
- [JRR200 Route Reflector Factory-Default Settings | 46](#)
- [Viewing Factory-Default Settings of JRR200 Route Reflector | 48](#)

JRR200 Route Reflector Initial Configuration Using the CLI

Access the CLI to perform the initial configuration.

1. Log in to the device as root. When the device is powered on with the factory-default configuration, you do not need to enter a password.
2. At the (%) prompt, type `cli` to start the CLI and press Enter. The prompt changes to an angle bracket (>) when you enter the CLI operational mode.

```
root% cli
root>
```

3. At the (>) prompt, type `configure` and press Enter. The prompt changes from > to # when you enter configuration mode.

```
root>configure
Entering configuration mode
[edit]
root#
```

4. Set the root authentication password by entering a cleartext password, an encrypted password, or an SSH public key string (DSA or RSA).

```
root# set system root-authentication plain-text-  
password  
New password: password  
Retype new password: password
```

5. Configure the route for the management interface (optional, required only if you do not connect the **MGMT** port directly to the management device).

```
root# set routing-options static route destination prefix next-hop gateway
```

6. Commit the configuration changes.

```
root# commit
```

7. Connect the **MGMT** port on the device to the Ethernet port on the management device using an RJ-45 cable.
8. The JRR200 route reflector **MGMT** port is internally mapped to the `em0` interface in Junos. By default, the management network interface (`em0`) is configured with DHCP enabled. If there is a DHCP server on the management network, then the JRR200 management network interface is automatically assigned an IP address. If there is no DHCP server on the management network then you need to configure the management network interface IP address by performing the following steps:
 - a. Delete the default management interface configuration.

```
root# delete interfaces em0
```

- b. Configure a new IP address for the management interface.

```
root# set interfaces em0 unit 0 family inet  
address address/prefix-length
```

- c. Commit the configuration changes.

```
root# commit
```

- d. Configure an IP address for the management device. Ensure that the IP address is on the same subnetwork as the management interface (em0).
9. When you have finished configuring the device, exit configuration mode:

```
[edit]
root# exit
```

JRR200 Route Reflector Factory-Default Settings

Your JRR200 route reflector comes configured with a factory-default configuration which has the ZTP configurations enabled when the JRR200 route reflector is shipped.

The below is the factory default configuration file of JRR200 route reflector.

```
interfaces {
  em0 {
    unit 0 {
      family inet {
        dhcp;
      }
    }
  }
}
interfaces {
  em2 {
    unit 0 {
      family inet {
        dhcp;
      }
    }
  }
}
interfaces {
  em3 {
    unit 0 {
      family inet {
        dhcp;
      }
    }
  }
}
```

```
    }  
  }  
  interfaces {  
    em4 {  
      unit 0 {  
        family inet {  
          dhcp;  
        }  
      }  
    }  
  }  
  interfaces {  
    em5 {  
      unit 0 {  
        family inet {  
          dhcp;  
        }  
      }  
    }  
  }  
  interfaces {  
    em6 {  
      unit 0 {  
        family inet {  
          dhcp;  
        }  
      }  
    }  
  }  
  interfaces {  
    em7 {  
      unit 0 {  
        family inet {  
          dhcp;  
        }  
      }  
    }  
  }  
  interfaces {  
    em8 {  
      unit 0 {  
        family inet {  
          dhcp;  
        }  
      }  
    }  
  }  
}
```

```
        }  
    }  
}  
}  
}  
}  
interfaces {  
    em9 {  
        unit 0 {  
            family inet {  
                dhcp;  
            }  
        }  
    }  
}  
}  
chassis {  
    auto-image-upgrade;  
}  
system {  
    processes {  
        dhcp-service {  
            traceoptions {  
                file dhcp_logfile size 10m;  
                level all;  
                flag all;  
            }  
        }  
    }  
}  
}
```

Viewing Factory-Default Settings of JRR200 Route Reflector

To view the factory-default settings on your JRR200 route reflector:

1. Log in as the root user and provide your credentials.
2. View the list of default config files:

```
user@host>file list /etc/config
```

3. View the required default config file.

```
user@host> file show /etc/config/<config file name>
```

When you commit changes to the configuration, a new configuration file is created, which becomes the active configuration. If the current active configuration fails, you can use the `load factory-default` command to revert to the factory-default configuration.

4

CHAPTER

Maintaining Components

Maintaining the JRR200 Chassis | 51

Maintaining the JRR200 Cooling System | 51

Maintaining the JRR200 Power System | 54

Maintaining the JRR200 Cables and Connectors | 60

Maintaining the JRR200 Chassis

IN THIS SECTION

- [Routine Maintenance Procedures for the JRR200 Route Reflector | 51](#)

Routine Maintenance Procedures for the JRR200 Route Reflector

For optimum performance of the JRR200 route reflector, perform the following preventive maintenance procedures regularly:

- Inspect the installation site for moisture, loose wires or cables, and excessive dust.
- Make sure that airflow is unobstructed around the JRR200 route reflector and into the air intake vents. Make sure that all power and grounding cables are arranged so that they do not obstruct access to other device components.
- Check the status LEDs on the front panel of the JRR200 route reflector.
- Periodically inspect the site to ensure that the grounding and power cables connected to the JRR200 route reflector are securely in place and that there is no moisture accumulating near the JRR200 route reflector.

Maintaining the JRR200 Cooling System

IN THIS SECTION

- [Maintaining the Fan Trays on the JRR200 Route Reflector | 52](#)
- [Replacing the JRR200 Route Reflector Fan Tray | 53](#)

Fan Tray 3 Fan 1

OK

Replacing the JRR200 Route Reflector Fan Tray

Each fan tray is a field-replaceable unit (FRU) installed in the rear panel of JRR200 route reflector. You can remove and replace the fan trays without powering off JRR200 route reflector or disrupting route reflector functions.

NOTE: All the fan trays must be installed and operational for optimal functioning of JRR200 route reflector.

To replace the fan tray:

1. Identify the physical location of the faulty fan tray on the rear panel of the chassis. [Figure 15 on page 53](#) shows how the fan trays are numbered.

Figure 15: JRR200 Route Reflector Fan Tray Numbering

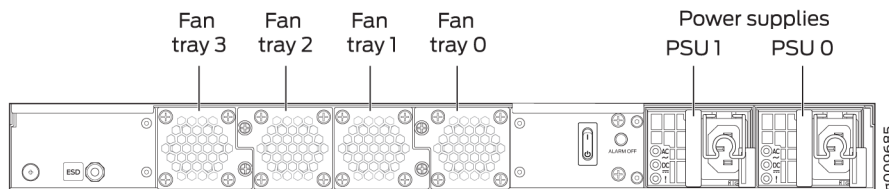

2. Attach an electrostatic discharge (ESD) grounding strap to your bare wrist, and connect the strap to the ESD point on the chassis.
3. Loosen the captive screws on the fan tray faceplate.
4. Grasp the captive screw and pull out the fan tray completely out of the chassis.
5. Insert the replacement fan tray straight into the chassis.
6. Tighten the captive screw on the fan tray faceplate to secure it in the chassis.

Maintaining the JRR200 Power System

IN THIS SECTION

- [Maintaining the JRR200 Route Reflector Power Supplies | 54](#)
- [Replacing the JRR200 Route Reflector AC Power Supply | 55](#)
- [Replacing the JRR200 Route Reflector DC Power Supply | 58](#)

Maintaining the JRR200 Route Reflector Power Supplies

IN THIS SECTION

- [Purpose | 54](#)
- [Action | 54](#)

Purpose

For optimum performance, verify the condition of the power supplies.

Action

On a regular basis:

- To check the status of the power supplies, issue the `show chassis environment pem` command. The output shown below is an example.

```
user@host> show chassis environment pem
PEM 0 status:
State                Online
Airflow              Front to Back
Temperature           OK
DC Output            Voltage(V) Current(A) Power(W) Load(%)
```

	12	10	120	18
PEM 1 status:				
State	Online			
Airflow	Front to Back			
Temperature	OK			
DC Output	Voltage(V)	Current(A)	Power(W)	Load(%)
	12	10	120	18

- Make sure that the power and grounding cables are arranged so that they do not obstruct access to other JRR200 route reflector components.
- Routinely check the status LEDs on the power supply faceplates to determine whether the power supplies are functioning normally. Each power supply faceplate displays three LEDs to indicate the status of the power supply.
- Check the power LED on the front panel of the device. Power supply failure or removal triggers an alarm that causes LEDs to light. You can display the associated error messages by issuing the following command:

```
user@host> show chassis alarms
```

- Periodically inspect the site to ensure that the grounding and power cables connected to the device are securely in place and that there is no moisture accumulating near the device.

Replacing the JRR200 Route Reflector AC Power Supply

IN THIS SECTION

- [Removing a JRR200 Route Reflector AC Power Supply | 56](#)
- [Installing a JRR200 Route Reflector AC Power Supply | 57](#)

Each AC power supply is a field-replaceable unit (FRU) installed in the rear panel of JRR200 route reflector. You can remove and replace the power supplies without powering off JRR200 route reflector or disrupting route reflector functions.

NOTE: All the power supplies must be installed and operational for optimal functioning of JRR200 route reflector.

Removing a JRR200 Route Reflector AC Power Supply

Ensure that you have the following parts and tools available:

- ESD grounding strap
- Antistatic bag or an antistatic mat
- Replacement power supply

To remove a power supply from JRR200 route reflector (see Figure 1):

1. Place the antistatic bag or the antistatic mat on a flat, stable surface.
2. Attach an electrostatic discharge (ESD) grounding strap to your bare wrist and connect the strap to the ESD point on the chassis.
3. If the AC power source outlet has a power switch, set it to the off (0) position and pull out the power cord connected to the power source outlet.
4. Remove the power cord from the power supply faceplate.
5. Slide the ejector lever toward the left until the power supply is unseated.
6. Grasp the power supply handle and pull firmly to slide the power supply halfway out of the chassis.
7. Place one hand under the power supply to support it and slide it completely out of the chassis. Take care not to touch power supply components, pins, leads, or solder connections.

Figure 16: Removing an AC Power Supply

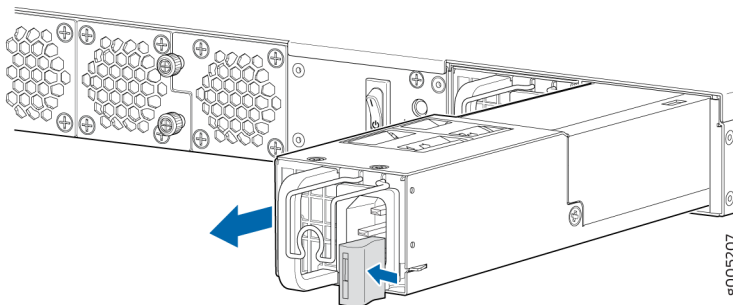

8. Place the power supply in the antistatic bag or on the antistatic mat placed on a flat, stable surface.

Installing a JRR200 Route Reflector AC Power Supply

Ensure that you have the following parts and tools available:

- ESD grounding strap



CAUTION: Do not mix AC and DC power supplies in the same chassis.

To install an AC power supply (see Figure 2):

1. Attach the ESD grounding strap to your bare wrist, and connect the strap to the ESD point on the chassis.
2. If the power supply slot has a cover panel on it, with one hand slide the ejector lever toward the left until it stops and using the other hand pull the handle of the cover panel outward to remove it. Save the cover panel for later use.
3. Taking care not to touch power supply pins, leads, or solder connections, remove the power supply from the bag.
4. Using both hands, place the power supply in the power supply slot on the rear panel of the JRR200 route reflector and slide it in until it is fully seated and the ejector lever fits into place. You will hear a distinct click when the power supply is fully seated in the chassis.

Figure 17: Installing an AC Power Supply

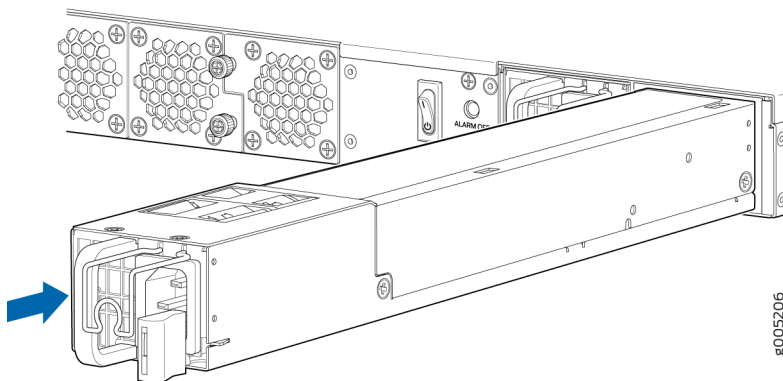

Replacing the JRR200 Route Reflector DC Power Supply

IN THIS SECTION

- [Removing a JRR200 Route Reflector DC Power Supply | 58](#)
- [Installing a JRR200 Route Reflector DC Power Supply | 59](#)

Each DC power supply is a field-replaceable unit (FRU) installed in the rear panel of the JRR200 device. You can remove and replace the power supplies without powering off the JRR200 device or disrupting route reflector functions.

NOTE: All the power supplies must be installed and operational for optimal functioning of the JRR200 device.

Removing a JRR200 Route Reflector DC Power Supply

Ensure that you have the following parts and tools available:

- ESD grounding strap
- Phillips (+) screwdriver, number 2
- Antistatic bag or an antistatic mat
- Replacement power supply

To remove a DC power supply (see Figure 3):

1. Place the antistatic bag or the antistatic mat on a flat, stable surface.
2. Attach the ESD grounding strap to your bare wrist, and connect the strap to the ESD point on the chassis.
3. Make sure that the voltage across the DC power source cables leads is 0 V and that there is no chance that the cables might become active during the removal process.
4. Remove the plastic cover from the input terminals by sliding the cover either to the left or right.
5. Unscrew the locking screws counterclockwise by using the screwdriver.
6. Remove the cable lugs from the input DC terminals.
7. Slide the ejector lever toward the left until the power supply is unseated.
8. Grasp the power supply handle and pull firmly to slide the power supply halfway out of the chassis.

9. Taking care not to touch power supply pins, leads, or solder connections, place one hand under the power supply to support it. Grasp the power supply handle with your other hand and pull the power supply completely out of the chassis.

Figure 18: Removing a DC Power Supply

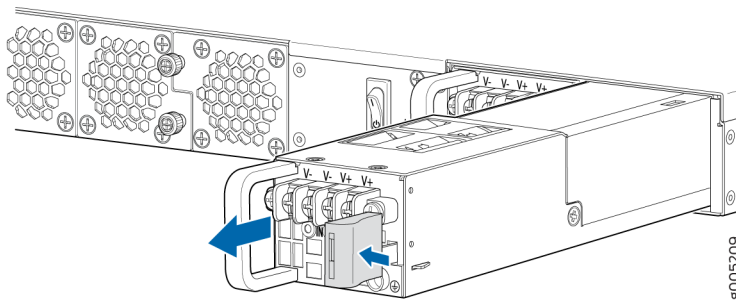

10. Place the power supply in the antistatic bag or on the antistatic mat placed on a flat, stable surface.

Installing a JRR200 Route Reflector DC Power Supply

Ensure that you have the following parts and tools available:

- ESD grounding strap



CAUTION: Do not mix AC and DC power supplies in the same chassis.

To install a DC power supply (see Figure 4):

1. Attach the ESD grounding strap to your bare wrist, and connect the strap to the ESD point on the chassis.
2. Taking care not to touch power supply pins, leads, or solder connections, remove the power supply from the bag.

- Using both hands, place the power supply in the power supply slot on the rear panel of the chassis and slide it in until it is fully seated and the ejector lever fits into place. You will hear a distinct click when the power supply is fully seated in the chassis.

Figure 19: Installing a DC Power Supply

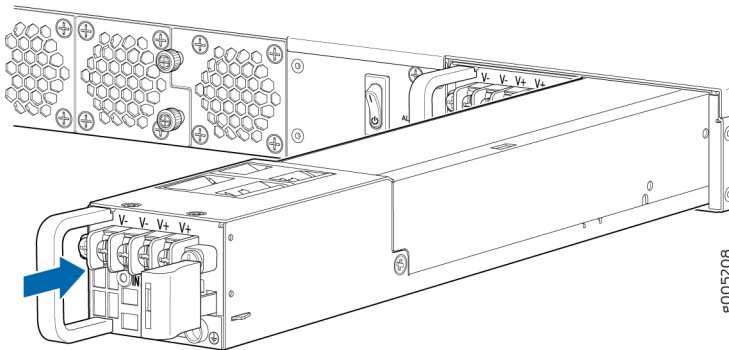

Maintaining the JRR200 Cables and Connectors

IN THIS SECTION

- [Maintaining JRR200 Route Reflector Network Cables | 60](#)
- [Replacing an SFP+ Transceiver on JRR200 Route Reflector | 62](#)

Maintaining JRR200 Route Reflector Network Cables

IN THIS SECTION

- [Purpose | 61](#)
- [Action | 61](#)

Purpose

For optimum performance, verify the condition of the network cables.

Action

On a regular basis:

- Secure excess cable in tidy loops that do not obstruct access to the device. Do not allow fastened loops of cable to dangle from the connector, because this stresses the cable at the fastening point. Putting fasteners on the loops helps maintain their shape.
- Keep the cable connections clean and free of dust and other particles, which can cause drops in the received power level. Always inspect cables and clean them if necessary before connecting an interface.
- Label both ends of the cables to identify them.

The following guidelines apply specifically to fiber-optic cables that connect to optical transceivers that are installed in Juniper Networks devices:

- When you unplug a fiber-optic cable, always cover the cable connector with the rubber safety cap.
- Anchor fiber-optic cables to avoid stress on the connectors. Be sure to secure fiber-optic cables so that they do not support their own weight as they hang to the floor. Never let fiber-optic cable hang free from the connector.
- Avoid bending fiber-optic cable beyond its bend radius. An arc smaller than a few inches can damage the cable and cause problems that are difficult to diagnose.
- Frequent plugging and unplugging of fiber-optic cable into and out of optical instruments can cause damage to the instruments that is expensive to repair. Instead, attach a short fiber extension to the optical equipment. Any wear and tear due to frequent plugging and unplugging is then absorbed by the short fiber extension, which is easy and inexpensive to replace.
- Keep fiber-optic cable connections clean. Small microdeposits of oil and dust in the canal of the transceiver or cable connector could cause loss of light, reducing signal power and possibly causing intermittent problems with the optical connection.
 - To clean the transceivers, use an appropriate fiber-cleaning device, such as RIFOCS Fiber Optic Adaptor Cleaning Wands (part number 946). Follow the directions for the cleaning kit you use.
 - After you clean an optical transceiver, make sure that the connector tip of the fiber-optic cable is clean. Use only an approved alcohol-free fiber-optic cable cleaning kit, such as the Opptex Cletop-S Fiber Cleaner. Follow the directions for the cleaning kit you use.

Replacing an SFP+ Transceiver on JRR200 Route Reflector

IN THIS SECTION

- Removing an SFP+ Transceiver | 62
- Installing an SFP+ Transceiver | 63

Small form-factor pluggable plus transceivers (SFP+) are enhanced SFP transceivers that provides support for data rates of up to 10 Gbps for fiber-optic or copper interfaces. You can remove and replace the SFP+ transceivers without powering off the device or disrupting device functions.

Figure 20: Small Form-Factor Pluggable (SFP) Transceiver

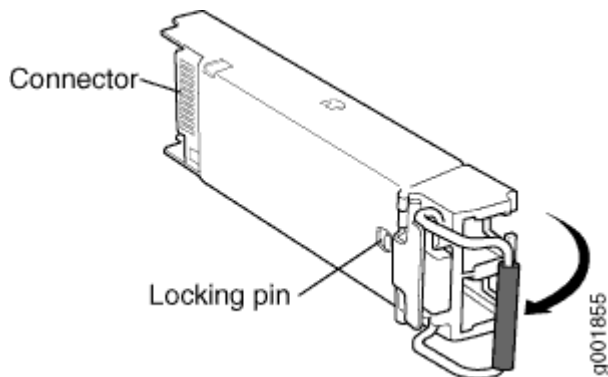

Removing an SFP+ Transceiver

To remove an SFP+ transceiver:

1. Have ready a replacement transceiver or a transceiver slot plug, an antistatic mat, and a rubber safety cap for the transceiver.
2. Attach an ESD grounding strap to your bare wrist, and connect the other end of the strap to an ESD grounding point.
3. Label the cables connected to the transceiver so that you can reconnect them correctly later.
4. Remove the cable connector from the transceiver. Immediately cover the transceiver and the end of the cable with a rubber safety cap.



LASER WARNING: Do not look directly into a fiber-optic transceiver or into the ends of fiber-optic cables. Fiber-optic transceivers and fiber-optic cables connected to a transceiver emit laser light that can damage your eyes.

5. Pull the ejector handle out from the transceiver to unlock the transceiver.



CAUTION: Make sure that you open the ejector handle completely until you hear it click. This prevents damage to the transceiver.

Use needlenose pliers to pull the ejector handle out from the transceiver.

6. Grasp the transceiver ejector handle, and pull the transceiver approximately 0.5 in. (1.3 cm) out of the interface port.
7. Using your fingers, grasp the body of the transceiver, and pull it the rest of the way out of the interface port.
8. Place a rubber safety cap over the transceiver.
9. Place the removed transceiver on an antistatic mat or in an electrostatic bag.



CAUTION: After removing a transceiver from the chassis, wait at least 30 seconds before reinserting it or inserting a transceiver into a different slot.

SEE ALSO

| [Installing an SFP+ Transceiver](#)

Installing an SFP+ Transceiver

To install an SFP+ transceiver:

1. Attach an ESD grounding strap to your bare wrist, and connect the other end of the strap to an ESD grounding point.
2. Take each transceiver to be installed out of its electrostatic bag, and identify the slot on the component where it will be installed.
3. Verify that each transceiver is covered by a rubber safety cap. If it is not, cover the transceiver with a safety cap.
4. Carefully align the transceiver with the slots in the component. The connectors should face the component.

5. Slide the transceiver until the connector is seated in the component slot. If you are unable to fully insert the transceiver, make sure the connector is facing the right way.
6. Close the ejector handle of the transceiver.
7. Remove the rubber safety cap from the transceiver and the end of the cable. Insert the cable into the transceiver.



LASER WARNING: Do not look directly into a fiber-optic transceiver or into the ends of fiber-optic cables. Fiber-optic transceivers and fiber-optic cables connected to a transceiver emit laser light that can damage your eyes.

SEE ALSO

Removing an SFP+ Transceiver

5

CHAPTER

Troubleshooting Hardware

Troubleshooting the JRR200 | 66

Troubleshooting the JRR200

IN THIS SECTION

- [Troubleshooting Resources for JRR200 Route Reflector | 66](#)
- [Chassis Component Alarm Conditions on JRR200 Route Reflector | 66](#)

Troubleshooting Resources for JRR200 Route Reflector

To troubleshoot JRR200 route reflector, use the command-line interface (CLI) and LEDs on the chassis:

- LEDs—When the JRR200 route reflector detects an alarm condition, the status LED on the front panel glows red.
- CLI—The CLI is the primary tool for controlling and troubleshooting hardware and network connectivity. Use the CLI to display more information about alarms. CLI commands display information about network connectivity derived from the ping and traceroute utilities.
- JTAC—If you need assistance during troubleshooting, you can contact the Juniper Networks Technical Assistance Center (JTAC) by using the Web or by telephone. If you encounter software problems, or problems with hardware components not discussed here, contact JTAC.

Chassis Component Alarm Conditions on JRR200 Route Reflector

You can monitor chassis alarms through the Status LED. When the JRR200 route reflector detects an alarm condition, the Status LED on the front panel glows red. The level of severity can be either major (steady red) or minor (blinking red). To view a more detailed description of the alarm cause, issue the `show chassis alarms` and `show system alarm` commands.

[Table 21 on page 67](#) describes alarms that can occur for the JRR200 route reflector chassis component.

Table 21: Alarms for JRR200 Route Reflector Chassis Components

Component	Alarm Conditions	Action	Alarm Severity
Fan	At least one of the fans have failed.	<ul style="list-style-type: none"> • Check and adjust the room temperature, if possible. • Check the air flow and ensure that the airflow through JRR200 route reflector is unobstructed. • Replace the failed fan tray to avoid failure of the other fan trays. • Open a support case using the Case Manager link at https://www.juniper.net/support/ or call 1-888-314-5822 (toll-free within the United States and Canada) or 1-408-745-9500 (from outside the United States). 	Steady red (major)
	The JRR200 route reflector chassis temperature is too warm.	<ul style="list-style-type: none"> • Check the room temperature. • Check the air flow. • Run all the Fans at full speed. • Open a support case using the Case Manager link at https://www.juniper.net/support/ or call 1-888-314-5822 (toll-free within the United States and Canada) or 1-408-745-9500 (from outside the United States). 	Yellow (minor)/Red (major)

Table 21: Alarms for JRR200 Route Reflector Chassis Components (Continued)

Component	Alarm Conditions	Action	Alarm Severity
	Missing fan tray	Install the missing fan tray.	Red (major)
	Fan over-speeding	<ul style="list-style-type: none"> • Check if the fan is spinning more than the configured speed. • Replace the fan tray as it is likely to fail. 	Yellow (minor)
	Fan spinning below its speed	<ul style="list-style-type: none"> • Check if the fan is spinning below the configured speed. • Replace the fan tray as it is likely to fail. 	Yellow (minor)
	Impeding fan failure	Replace the fan tray.	Yellow (minor)
Power supply	A power supply has failed.	Replace the power supply.	Steady red (major)
	A power supply unit is not present.	Install a power supply unit in the empty slot. JRR200 route reflector requires two power supply units to be installed.	
	Power cord is not connected.	Verify and ensure that the power cord is connected properly.	
	Power supply fan failure.	As it is a non-recoverable fault, replace the power supply.	Yellow (minor)

Table 21: Alarms for JRR200 Route Reflector Chassis Components (Continued)

Component	Alarm Conditions	Action	Alarm Severity
	Input failure to the power supply	<ul style="list-style-type: none"> • Check the voltage of the power source if it is in the operating range. • Open a support case using the Case Manager link at https://www.juniper.net/support/ or call 1-888-314-5822 (toll-free within the United States and Canada) or 1-408-745-9500 (from outside the United States). 	Red (major)
	Power supply drawing more current than it should.	Open a support case using the Case Manager link at https://www.juniper.net/support/ or call 1-888-314-5822 (toll-free within the United States and Canada) or 1-408-745-9500 (from outside the United States).	Yellow (minor)
	Unrecognized power supply	Open a support case using the Case Manager link at https://www.juniper.net/support/ or call 1-888-314-5822 (toll-free within the United States and Canada) or 1-408-745-9500 (from outside the United States).	Red (major)
	Power supply not powered on.	Connect the power supply to the power source.	Red (major)

Table 21: Alarms for JRR200 Route Reflector Chassis Components (Continued)

Component	Alarm Conditions	Action	Alarm Severity
	Power supply internal devices failure.	<ul style="list-style-type: none"> • Replace the power supply. • Open a support case using the Case Manager link at https://www.juniper.net/support/ or call 1-888-314-5822 (toll-free within the United States and Canada) or 1-408-745-9500 (from outside the United States). 	Red (major)
	Mix of AC and DC power supplies installed.	Check if all the power supplies installed are of the same type.	Yellow (minor)
USB	USB Device not detected	<ul style="list-style-type: none"> • Check if there is any power supply issue to the USB slot. • Check for the port level failures. • Check for USB link to port from PCH failures. • Check if the USB is faulty, and replace the faulty USB. 	Yellow (minor)



CHAPTER

Contacting Customer Support and Returning the Chassis or Components

[Returning the JRR200 Chassis or Components | 72](#)

Returning the JRR200 Chassis or Components

IN THIS SECTION

- [Returning a JRR200 Route Reflector or Hardware Component to Juniper Networks | 72](#)
- [Listing the JRR200 Route Reflector Component Details with the CLI | 73](#)
- [Locating the Serial Number on the JRR200 Route Reflector or Component | 74](#)
- [Contacting Customer Support | 74](#)
- [Packing a JRR200 Route Reflector or its Components for Shipping | 75](#)

Returning a JRR200 Route Reflector or Hardware Component to Juniper Networks

To return a JRR200 route reflector or hardware component to Juniper Networks for repair or replacement, follow this procedure:

1. Determine the part number and serial number of the JRR200 route reflector or component. See ["Locating the Serial Number on the JRR200 Route Reflector or Component" on page 74](#).
2. Obtain a Return Materials Authorization (RMA) number from JTAC. See ["Contacting Customer Support" on page 74](#).

NOTE: Do not return the JRR200 route reflector or any component to Juniper Networks unless you have first obtained an RMA number. Juniper Networks reserves the right to refuse shipments that do not have an RMA. Refused shipments are returned to the customer via collect freight.

3. Pack the JRR200 route reflector or component for shipping.

For more information about return and repair policies, see the customer support webpage at <https://www.juniper.net/support/guidelines.html>.

For product problems or technical support issues, open a support case using the Case Manager link at <https://support.juniper.net/support/> or call 1-888-314-JTAC (within the United States) or 1-408-745-9500 (outside the United States).

Listing the JRR200 Route Reflector Component Details with the CLI

Before contacting Juniper Networks to request a Return Materials Authorization (RMA), you must find the serial number on the JRR200 route reflector or component. To list all the JRR200 route reflector components and their serial numbers, enter the following CLI command:

```
user@host> show chassis hardware
Hardware inventory:
Item            Version  Part number  Serial number  Description
Chassis                EN2716AR0001  JRR200
Midplane              REV 01   650-087064   16071005283   JRR200
Pseudo CB 0
Routing Engine 0      BUILTIN    BUILTIN      RE-JRR200
Power Supply 0       REV 04    740-041741   1GA26270637   JPSU-650W-AC-AFO
Power Supply 1       REV 04    740-041741   1GA26270636   JPSU-650W-AC-AFO
Fan Tray 0                                JRR200 0, Front to Back Airflow - AFO
Fan Tray 1                                JRR200 1, Front to Back Airflow - AFO
Fan Tray 2                                JRR200 2, Front to Back Airflow - AFO
Fan Tray 3                                JRR200 3, Front to Back Airflow - AFO
```

In the above output SFP+ or the PIC information is not displayed. To view the SFP+ or the PIC information you need to enter into the host OS and use `ethtool -m <interface-name>` to get the details.

```
user@:~ # rsh -JU __juniper_private4__ 192.168.1.1
user@local-node:~# ethtool -m eth3 |grep Vendor
Vendor name           : FINISAR CORP.
Vendor OUI            : 00:90:65
Vendor PN             : FTLX8571D3BNL-J1
Vendor rev            : A
```

Locating the Serial Number on the JRR200 Route Reflector or Component

IN THIS SECTION

- Locating the Chassis Serial Number ID Label | 74
- Locating the Serial Number ID Labels on FRUs | 74

If you are returning a device or hardware component to Juniper Networks for repair or replacement, you must locate the serial number of the device or component. You must provide the serial number to the Juniper Networks Technical Assistance Center (JTAC) when you contact them to obtain Return Materials Authorization (RMA).

If the device is operational and you can access the CLI, you can list serial numbers for the device and for some components with a CLI command. If you do not have access to the CLI or if the serial number for the component does not appear in the command output, you can locate the serial number ID label on the physical device or component.

Locating the Chassis Serial Number ID Label

The serial number ID label is located on the rear panel of the JRR200 route reflector.

Locating the Serial Number ID Labels on FRUs

The power supplies and fan trays installed in the JRR200 route reflector are field-replaceable units (FRUs). The serial number ID label is on the top of the FRUs.

Contacting Customer Support

Once you have located the serial numbers of the device or component, you can return the device or component for repair or replacement. For this, you need to contact Juniper Networks Technical Assistance Center (JTAC).

You can contact JTAC 24 hours a day, 7 days a week, using any of the following methods:

- On the Web: Using the Service Request Manager link at <https://support.juniper.net/support/>
- By telephone:

- From the US and Canada: 1-888-314-JTAC
- From all other locations: 1-408-745-9500

NOTE: If contacting JTAC by telephone, enter your 12-digit service request number followed by the pound (#) key if this is an existing case, or press the star (*) key to be routed to the next available support engineer.

When requesting support from JTAC by telephone, be prepared to provide the following information:

- Your existing service request number, if you have one
- Details of the failure or problem
- Type of activity being performed on the JRR200 route reflector when the problem occurred
- Configuration data displayed by one or more `show` commands
- Your name, organization name, telephone number, fax number, and shipping address

The support representative validates your request and issues an RMA number for return of the component.

Packing a JRR200 Route Reflector or its Components for Shipping

IN THIS SECTION

- [Packing the JRR200 Route Reflector for Shipment | 76](#)
- [Packing the JRR200 Route Reflector Components for Shipment | 76](#)

Before you pack a JRR200 route reflector or component:

- Ensure that you have taken the necessary precautions to prevent electrostatic discharge (ESD) damage.
- Retrieve the original shipping carton and packing materials. Contact your JTAC representative if you do not have these materials, to learn about approved packing materials. See "[Contacting Customer Support](#)" on page 74.

Ensure that you have the following parts and tools available:

- ESD grounding strap
- Antistatic bag, one for each component
- Phillips (+) screwdriver, number 2

Packing the JRR200 Route Reflector for Shipment

To pack the JRR200 route reflector for shipment:

1. Attach an electrostatic discharge (ESD) grounding strap to your bare wrist and connect the strap to the ESD point on the chassis or to an outside ESD point if the device is disconnected from earth ground.
2. On the console or other management device connected to the JRR200 route reflector, enter CLI operational mode and issue the following command to shut down the JRR200 route reflector software:

```
user@host> request system power-off
```
3. Wait until a message appears on the console confirming that the services have stopped, and then physically turn off power by pressing the power switch that is on the rear of the route reflector.
4. Disconnect power cables from the JRR200 route reflector.
5. Remove the cables that connect to all external devices.
6. If the JRR200 route reflector is installed in a rack, have one person support the weight of the route reflector while another person unscrews and removes the mounting screws.
7. Place the JRR200 route reflector in the shipping carton.
8. Cover the JRR200 route reflector with an ESD bag, and place the packing foam on top of and around the device.
9. Replace the accessory box on top of the packing foam.
10. Securely tape the box closed.
11. Write the Return Materials Authorization (RMA) number on the exterior of the box to ensure proper tracking.

Packing the JRR200 Route Reflector Components for Shipment

Follow these guidelines for packing and shipping individual components of the JRR200 route reflector:

- When you return a component, make sure that it is adequately protected with packing materials and packed so that the pieces are prevented from moving around inside the carton.
- Use the original shipping materials if they are available.
- Place the individual component in an electrostatic bag.

- Write the Return Materials Authorization (RMA) number on the exterior of the box to ensure proper tracking.



CAUTION: Do not stack any of the JRR200 route reflector components during packing.

7

CHAPTER

Safety and Compliance Information

- General Safety Guidelines and Warnings | 80
- Definitions of Safety Warning Levels | 81
- Restricted Access Warning | 83
- Fire Safety Requirements | 84
- Qualified Personnel Warning | 85
- Warning Statement for Norway and Sweden | 86
- Installation Instructions Warning | 86
- Chassis and Component Lifting Guidelines | 87
- Ramp Warning | 88
- Rack-Mounting and Cabinet-Mounting Warnings | 88
- Grounded Equipment Warning | 92
- Laser and LED Safety Guidelines and Warnings | 93
- Radiation from Open Port Apertures Warning | 96
- Maintenance and Operational Safety Guidelines and Warnings | 97
- General Electrical Safety Guidelines and Warnings | 103
- Prevention of Electrostatic Discharge Damage | 104
- AC Power Electrical Safety Guidelines | 106
- AC Power Disconnection Warning | 107
- DC Power Disconnection Warning | 108
- DC Power Grounding Requirements and Warning | 109

[DC Power Wiring Sequence Warning | 110](#)

[DC Power Wiring Terminations Warning | 112](#)

[Multiple Power Supplies Disconnection Warning | 113](#)

[TN Power Warning | 114](#)

[Action to Take After an Electrical Accident | 114](#)

[JRR200 Agency Approvals and Regulatory Compliance Information | 115](#)

General Safety Guidelines and Warnings

The following guidelines help ensure your safety and protect the device from damage. The list of guidelines might not address all potentially hazardous situations in your working environment, so be alert and exercise good judgment at all times.

- Perform only the procedures explicitly described in the hardware documentation for this device. Make sure that only authorized service personnel perform other system services.
- Keep the area around the device clear and free from dust before, during, and after installation.
- Keep tools away from areas where people could trip over them while walking.
- Do not wear loose clothing or jewelry, such as rings, bracelets, or chains, which could become caught in the device.
- Wear safety glasses if you are working under any conditions that could be hazardous to your eyes.
- Do not perform any actions that create a potential hazard to people or make the equipment unsafe.
- Never attempt to lift an object that is too heavy for one person to handle.
- Never install or manipulate wiring during electrical storms.
- Never install electrical jacks in wet locations unless the jacks are specifically designed for wet environments.
- Operate the device only when it is properly grounded.
- Follow the instructions in this guide to properly ground the device to earth.
- Replace fuses only with fuses of the same type and rating.
- Do not open or remove chassis covers or sheet-metal parts unless instructions are provided in the hardware documentation for this device. Such an action could cause severe electrical shock.
- Do not push or force any objects through any opening in the chassis frame. Such an action could result in electrical shock or fire.
- Avoid spilling liquid onto the chassis or onto any device component. Such an action could cause electrical shock or damage the device.
- Avoid touching uninsulated electrical wires or terminals that have not been disconnected from their power source. Such an action could cause electrical shock.

- Some parts of the chassis, including AC and DC power supply surfaces, power supply unit handles, SFB card handles, and fan tray handles might become hot. The following label provides the warning for hot surfaces on the chassis:



- Always ensure that all modules, power supplies, and cover panels are fully inserted and that the installation screws are fully tightened.

Definitions of Safety Warning Levels

The documentation uses the following levels of safety warnings (there are two *Warning* formats):

NOTE: You might find this information helpful in a particular situation, or you might overlook this important information if it was not highlighted in a Note.



CAUTION: You need to observe the specified guidelines to prevent minor injury or discomfort to you or severe damage to the device.

Attention Veillez à respecter les consignes indiquées pour éviter toute incommodité ou blessure légère, voire des dégâts graves pour l'appareil.



LASER WARNING: This symbol alerts you to the risk of personal injury from a laser.

Avertissement Ce symbole signale un risque de blessure provoquée par rayon laser.



WARNING: This symbol means danger. You are in a situation that could cause bodily injury. Before you work on any equipment, be aware of the hazards involved with electrical circuitry, and familiarize yourself with standard practices for preventing accidents.

Waarschuwing Dit waarschuwingssymbool betekent gevaar. U verkeert in een situatie die lichamelijk letsel kan veroorzaken. Voordat u aan enige apparatuur gaat werken, dient u zich bewust te zijn van de bij elektrische schakelingen betrokken risico's en dient u op de hoogte te zijn van standaard maatregelen om ongelukken te voorkomen.

Varoitus Tämä varoitusmerkki merkitsee vaaraa. Olet tilanteessa, joka voi johtaa ruumiinvammaan. Ennen kuin työskentelet minkään laitteiston parissa, ota selvää sähkökytkentöihin liittyvistä vaaroista ja tavanomaisista onnettomuuksien ehkäisykeinoista.

Avertissement Ce symbole d'avertissement indique un danger. Vous vous trouvez dans une situation pouvant causer des blessures ou des dommages corporels. Avant de travailler sur un équipement, soyez conscient des dangers posés par les circuits électriques et familiarisez-vous avec les procédures couramment utilisées pour éviter les accidents.

Warnung Dieses Warnsymbol bedeutet Gefahr. Sie befinden sich in einer Situation, die zu einer Körperverletzung führen könnte. Bevor Sie mit der Arbeit an irgendeinem Gerät beginnen, seien Sie sich der mit elektrischen Stromkreisen verbundenen Gefahren und der Standardpraktiken zur Vermeidung von Unfällen bewußt.

Avvertenza Questo simbolo di avvertenza indica un pericolo. La situazione potrebbe causare infortuni alle persone. Prima di lavorare su qualsiasi apparecchiatura, occorre conoscere i pericoli relativi ai circuiti elettrici ed essere al corrente delle pratiche standard per la prevenzione di incidenti.

Advarsel Dette varselsymbolet betyr fare. Du befinner deg i en situasjon som kan føre til personskade. Før du utfører arbeid på utstyr, må du være oppmerksom på de faremomentene som elektriske kretser innebærer, samt gjøre deg kjent med vanlig praksis når det gjelder å unngå ulykker.

Aviso Este símbolo de aviso indica perigo. Encontra-se numa situação que lhe poderá causar danos físicos. Antes de começar a trabalhar com qualquer equipamento, familiarize-se com os perigos relacionados com circuitos eléctricos, e com quaisquer práticas comuns que possam prevenir possíveis acidentes.

¡Atención! Este símbolo de aviso significa peligro. Existe riesgo para su integridad física. Antes de manipular cualquier equipo, considerar los riesgos que entraña la corriente eléctrica y familiarizarse con los procedimientos estándar de prevención de accidentes.

Varning! Denna varningssymbol signalerar fara. Du befinner dig i en situation som kan leda till personskada. Innan du utför arbete på någon utrustning måste du vara medveten om farorna med elkretsar och känna till vanligt förfarande för att förebygga skador.

Restricted Access Warning



WARNING: This unit is intended for installation in restricted access areas. A restricted access area is an area to which access can be gained only by service personnel through the use of a special tool, lock and key, or other means of security, and which is controlled by the authority responsible for the location.

Waarschuwing Dit toestel is bedoeld voor installatie op plaatsen met beperkte toegang. Een plaats met beperkte toegang is een plaats waar toegang slechts door servicepersoneel verkregen kan worden door middel van een speciaal instrument, een slot en sleutel, of een ander veiligheidsmiddel, en welke beheerd wordt door de overheidsinstantie die verantwoordelijk is voor de locatie.

Varoitus Tämä laite on tarkoitettu asennettavaksi paikkaan, johon pääsy on rajoitettua. Paikka, johon pääsy on rajoitettua, tarkoittaa paikkaa, johon vain huoltohenkilöstö pääsee jonkin erikoistyökalun, lukkoon sopivan avaimen tai jonkin muun turvalaitteen avulla ja joka on paikasta vastuussa olevien toimivaltaisten henkilöiden valvoma.

Avertissement Cet appareil est à installer dans des zones d'accès réservé. Ces dernières sont des zones auxquelles seul le personnel de service peut accéder en utilisant un outil spécial, un mécanisme de verrouillage et une clé, ou tout autre moyen de sécurité. L'accès aux zones de sécurité est sous le contrôle de l'autorité responsable de l'emplacement.

Warnung Diese Einheit ist zur Installation in Bereichen mit beschränktem Zutritt vorgesehen. Ein Bereich mit beschränktem Zutritt ist ein Bereich, zu dem nur Wartungspersonal mit einem Spezialwerkzeugs, Schloß und Schlüssel oder anderer Sicherheitsvorkehrungen Zugang hat, und der von dem für die Anlage zuständigen Gremium kontrolliert wird.

Avvertenza Questa unità deve essere installata in un'area ad accesso limitato. Un'area ad accesso limitato è un'area accessibile solo a personale di assistenza tramite un'attrezzo speciale, lucchetto, o altri dispositivi di sicurezza, ed è controllata dall'autorità responsabile della zona.

Advarsel Denne enheten er laget for installasjon i områder med begrenset adgang. Et område med begrenset adgang gir kun adgang til servicepersonale som bruker et spesielt verktøy, lås og nøkkel, eller en annen sikkerhetsanordning, og det kontrolleres av den autoriteten som er ansvarlig for området.

Aviso Esta unidade foi concebida para instalação em áreas de acesso restrito. Uma área de acesso restrito é uma área à qual apenas tem acesso o pessoal de serviço autorizado,

que possua uma ferramenta, chave e fechadura especial, ou qualquer outra forma de segurança. Esta área é controlada pela autoridade responsável pelo local.

¡Atención! Esta unidad ha sido diseñada para instalarse en áreas de acceso restringido. Área de acceso restringido significa un área a la que solamente tiene acceso el personal de servicio mediante la utilización de una herramienta especial, cerradura con llave, o algún otro medio de seguridad, y que está bajo el control de la autoridad responsable del local.

Warning! Denna enhet är avsedd för installation i områden med begränsat tillträde. Ett område med begränsat tillträde får endast tillträdas av servicepersonal med ett speciellt verktyg, lås och nyckel, eller annan säkerhetsanordning, och kontrolleras av den auktoritet som ansvarar för området.

Fire Safety Requirements

IN THIS SECTION

- [Fire Suppression | 85](#)
- [Fire Suppression Equipment | 85](#)

In the event of a fire emergency, the safety of people is the primary concern. You should establish procedures for protecting people in the event of a fire emergency, provide safety training, and properly provision fire-control equipment and fire extinguishers.

In addition, you should establish procedures to protect your equipment in the event of a fire emergency. Juniper Networks products should be installed in an environment suitable for electronic equipment. We recommend that fire suppression equipment be available in the event of a fire in the vicinity of the equipment and that all local fire, safety, and electrical codes and ordinances be observed when you install and operate your equipment.

Fire Suppression

In the event of an electrical hazard or an electrical fire, you should first turn power off to the equipment at the source. Then use a Type C fire extinguisher, which uses noncorrosive fire retardants, to extinguish the fire.

Fire Suppression Equipment

Type C fire extinguishers, which use noncorrosive fire retardants such as carbon dioxide and Halotron™, are most effective for suppressing electrical fires. Type C fire extinguishers displace oxygen from the point of combustion to eliminate the fire. For extinguishing fire on or around equipment that draws air from the environment for cooling, you should use this type of inert oxygen displacement extinguisher instead of an extinguisher that leaves residues on equipment.

Do not use multipurpose Type ABC chemical fire extinguishers (dry chemical fire extinguishers). The primary ingredient in these fire extinguishers is monoammonium phosphate, which is very sticky and difficult to clean. In addition, in the presence of minute amounts of moisture, monoammonium phosphate can become highly corrosive and corrodes most metals.

Any equipment in a room in which a chemical fire extinguisher has been discharged is subject to premature failure and unreliable operation. The equipment is considered to be irreparably damaged.

NOTE: To keep warranties effective, do not use a dry chemical fire extinguisher to control a fire at or near a Juniper Networks device. If a dry chemical fire extinguisher is used, the unit is no longer eligible for coverage under a service agreement.

We recommend that you dispose of any irreparably damaged equipment in an environmentally responsible manner.

Qualified Personnel Warning



WARNING: Only trained and qualified personnel should install or replace the device.
Waarschuwing Installatie en reparaties mogen uitsluitend door getraind en bevoegd personeel uitgevoerd worden.

Varoitus Ainoastaan koulutettu ja pätevä henkilökunta saa asentaa tai vaihtaa tämän laitteen.

Avertissement Tout installation ou remplacement de l'appareil doit être réalisé par du personnel qualifié et compétent.

Warnung Gerät nur von geschultem, qualifiziertem Personal installieren oder auswechseln lassen.

Avvertenza Solo personale addestrato e qualificato deve essere autorizzato ad installare o sostituire questo apparecchio.

Advarsel Kun kvalifisert personell med riktig opplæring bør montere eller bytte ut dette utstyret.

Aviso Este equipamento deverá ser instalado ou substituído apenas por pessoal devidamente treinado e qualificado.

¡Atención! Estos equipos deben ser instalados y reemplazados exclusivamente por personal técnico adecuadamente preparado y capacitado.

Warning! Denna utrustning ska endast installeras och bytas ut av utbildad och kvalificerad personal.

Warning Statement for Norway and Sweden



WARNING: The equipment must be connected to an earthed mains socket-outlet.

Advarsel Apparatet skal kobles til en jordet stikkontakt.

Warning! Apparaten skall anslutas till jordat nätuttag.

Installation Instructions Warning



WARNING: Read the installation instructions before you connect the device to a power source.

Waarschuwing Raadpleeg de installatie-aanwijzingen voordat u het systeem met de voeding verbindt.

Varoitus Lue asennusohjeet ennen järjestelmän yhdistämistä virtalähteeseen.

Avertissement Avant de brancher le système sur la source d'alimentation, consulter les directives d'installation.

Warnung Lesen Sie die Installationsanweisungen, bevor Sie das System an die Stromquelle anschließen.

Avvertenza Consultare le istruzioni di installazione prima di collegare il sistema all'alimentatore.

Advarsel Les installasjonsinstruksjonene før systemet kobles til strømkilden.

Aviso Leia as instruções de instalação antes de ligar o sistema à sua fonte de energia.

¡Atención! Ver las instrucciones de instalación antes de conectar el sistema a la red de alimentación.

Varning! Läs installationsanvisningarna innan du kopplar systemet till dess strömförsörjningsenhet.

Chassis and Component Lifting Guidelines

- Before moving the device to a site, ensure that the site meets the power, environmental, and clearance requirements.
- Before lifting or moving the device, disconnect all external cables and wires.
- As when lifting any heavy object, ensure that your legs bear most of the weight rather than your back. Keep your knees bent and your back relatively straight. Do not twist your body as you lift. Balance the load evenly and be sure that your footing is firm.
- Use the following lifting guidelines to lift devices and components:
 - Up to 39.7 lb (18 kg): One person.
 - From 39.7 lb (18 kg) to 70.5 lb (32 kg): Two or more people.
 - From 70.5 lb (32 kg) to 121.2 lb (55 kg): Three or more people.

- Above 121.2 lb (55 kg): Use material handling systems (such as levers, slings, lifts, and so on). When this is not practical, engage specially trained persons or systems (such as riggers or movers).

Ramp Warning



WARNING: When installing the device, do not use a ramp inclined at more than 10 degrees.

Waarschuwing Gebruik een oprijplaat niet onder een hoek van meer dan 10 graden.

Varoitus Älä käytä sellaista kaltevaa pintaa, jonka kaltevuus ylittää 10 astetta.

Avertissement Ne pas utiliser une rampe dont l'inclinaison est supérieure à 10 degrés.

Warnung Keine Rampen mit einer Neigung von mehr als 10 Grad verwenden.

Avvertenza Non usare una rampa con pendenza superiore a 10 gradi.

Advarsel Bruk aldri en rampe som heller mer enn 10 grader.

Aviso Não utilize uma rampa com uma inclinação superior a 10 graus.

¡Atención! No usar una rampa inclinada más de 10 grados.

Warning! Använd inte ramp med en lutning på mer än 10 grader.

Rack-Mounting and Cabinet-Mounting Warnings

Ensure that the rack or cabinet in which the device is installed is evenly and securely supported. Uneven mechanical loading could lead to a hazardous condition.



WARNING: To prevent bodily injury when mounting or servicing the device in a rack, take the following precautions to ensure that the system remains stable. The following directives help maintain your safety:

- Install the device in a rack that is secured to the building structure.

- Mount the device at the bottom of the rack if it is the only unit in the rack.
- When mounting the device on a partially filled rack, load the rack from the bottom to the top, with the heaviest component at the bottom of the rack.
- If the rack is provided with stabilizing equipment, install the stabilizers before mounting or servicing the device in the rack.

Waarschuwing Om lichamelijk letsel te voorkomen wanneer u dit toestel in een rek monteert of het daar een servicebeurt geeft, moet u speciale voorzorgsmaatregelen nemen om ervoor te zorgen dat het toestel stabiel blijft. De onderstaande richtlijnen worden verstrekt om uw veiligheid te verzekeren:

- De Juniper Networks switch moet in een stellage worden geïnstalleerd die aan een bouwsel is verankerd.
- Dit toestel dient onderaan in het rek gemonteerd te worden als het toestel het enige in het rek is.
- Wanneer u dit toestel in een gedeeltelijk gevuld rek monteert, dient u het rek van onderen naar boven te laden met het zwaarste onderdeel onderaan in het rek.
- Als het rek voorzien is van stabiliseringshulpmiddelen, dient u de stabilisatoren te monteren voordat u het toestel in het rek monteert of het daar een servicebeurt geeft.

Varoitus Kun laite asetetaan telineeseen tai huolletaan sen ollessa telineessä, on noudatettava erityisiä varotoimia järjestelmän vakavuuden säilyttämiseksi, jotta vältytään loukkaantumiselta. Noudata seuraavia turvallisuusohjeita:

- Juniper Networks switch on asennettava telineeseen, joka on kiinnitetty rakennukseen.
- Jos telineessä ei ole muita laitteita, aseta laite telineen alaosaan.
- Jos laite asetetaan osaksi täytettyyn telineeseen, aloita kuormittaminen sen alaosasta kaikkein raskaimmalla esineellä ja siirry sitten sen yläosaan.
- Jos telinettä varten on vakaimet, asenna ne ennen laitteen asettamista telineeseen tai sen huoltamista siinä.

Avertissement Pour éviter toute blessure corporelle pendant les opérations de montage ou de réparation de cette unité en casier, il convient de prendre des précautions spéciales afin de maintenir la stabilité du système. Les directives ci-dessous sont destinées à assurer la protection du personnel:

- Le rack sur lequel est monté le Juniper Networks switch doit être fixé à la structure du bâtiment.
- Si cette unité constitue la seule unité montée en casier, elle doit être placée dans le bas.
- Si cette unité est montée dans un casier partiellement rempli, charger le casier de bas en haut en plaçant l'élément le plus lourd dans le bas.
- Si le casier est équipé de dispositifs stabilisateurs, installer les stabilisateurs avant de monter ou de réparer l'unité en casier.

Warnung Zur Vermeidung von Körperverletzung beim Anbringen oder Warten dieser Einheit in einem Gestell müssen Sie besondere Vorkehrungen treffen, um sicherzustellen, daß das System stabil bleibt. Die folgenden Richtlinien sollen zur Gewährleistung Ihrer Sicherheit dienen:

- Der Juniper Networks switch muß in einem Gestell installiert werden, das in der Gebäudestruktur verankert ist.
- Wenn diese Einheit die einzige im Gestell ist, sollte sie unten im Gestell angebracht werden.
- Bei Anbringung dieser Einheit in einem zum Teil gefüllten Gestell ist das Gestell von unten nach oben zu laden, wobei das schwerste Bauteil unten im Gestell anzubringen ist.
- Wird das Gestell mit Stabilisierungszubehör geliefert, sind zuerst die Stabilisatoren zu installieren, bevor Sie die Einheit im Gestell anbringen oder sie warten.

Avvertenza Per evitare infortuni fisici durante il montaggio o la manutenzione di questa unità in un supporto, occorre osservare speciali precauzioni per garantire che il sistema rimanga stabile. Le seguenti direttive vengono fornite per garantire la sicurezza personale:

- Il Juniper Networks switch deve essere installato in un telaio, il quale deve essere fissato alla struttura dell'edificio.
- Questa unità deve venire montata sul fondo del supporto, se si tratta dell'unica unità da montare nel supporto.
- Quando questa unità viene montata in un supporto parzialmente pieno, caricare il supporto dal basso all'alto, con il componente più pesante sistemato sul fondo del supporto.

- Se il supporto è dotato di dispositivi stabilizzanti, installare tali dispositivi prima di montare o di procedere alla manutenzione dell'unità nel supporto.

Advarsel Unngå fysiske skader under montering eller reparasjonsarbeid på denne enheten når den befinner seg i et kabinett. Vær nøye med at systemet er stabilt. Følgende retningslinjer er gitt for å verne om sikkerheten:

- Juniper Networks switch må installeres i et stativ som er forankret til bygningsstrukturen.
- Denne enheten bør monteres nederst i kabinettet hvis dette er den eneste enheten i kabinettet.
- Ved montering av denne enheten i et kabinett som er delvis fylt, skal kabinettet lastes fra bunnen og opp med den tyngste komponenten nederst i kabinettet.
- Hvis kabinettet er utstyrt med stabiliseringsutstyr, skal stabilisatorene installeres før montering eller utføring av reparasjonsarbeid på enheten i kabinettet.

Aviso Para se prevenir contra danos corporais ao montar ou reparar esta unidade numa estante, deverá tomar precauções especiais para se certificar de que o sistema possui um suporte estável. As seguintes directrizes ajudá-lo-ão a efectuar o seu trabalho com segurança:

- O Juniper Networks switch deverá ser instalado numa prateleira fixa à estrutura do edifício.
- Esta unidade deverá ser montada na parte inferior da estante, caso seja esta a única unidade a ser montada.
- Ao montar esta unidade numa estante parcialmente ocupada, coloque os itens mais pesados na parte inferior da estante, arrumando-os de baixo para cima.
- Se a estante possuir um dispositivo de estabilização, instale-o antes de montar ou reparar a unidade.

¡Atención! Para evitar lesiones durante el montaje de este equipo sobre un bastidor, oerriormente durante su mantenimiento, se debe poner mucho cuidado en que el sistema quede bien estable. Para garantizar su seguridad, proceda según las siguientes instrucciones:

- El Juniper Networks switch debe instalarse en un bastidor fijado a la estructura del edificio.

- Colocar el equipo en la parte inferior del bastidor, cuando sea la única unidad en el mismo.
- Cuando este equipo se vaya a instalar en un bastidor parcialmente ocupado, comenzar la instalación desde la parte inferior hacia la superior colocando el equipo más pesado en la parte inferior.
- Si el bastidor dispone de dispositivos estabilizadores, instalar éstos antes de montar o proceder al mantenimiento del equipo instalado en el bastidor.

Warning! För att undvika kroppsskada när du installerar eller utför underhållsarbete på denna enhet på en ställning måste du vidta särskilda försiktighetsåtgärder för att försäkra dig om att systemet står stadigt. Följande riktlinjer ges för att trygga din säkerhet:

- Juniper Networks switch måste installeras i en ställning som är förankrad i byggnadens struktur.
- Om denna enhet är den enda enheten på ställningen skall den installeras längst ned på ställningen.
- Om denna enhet installeras på en delvis fylld ställning skall ställningen fyllas nedifrån och upp, med de tyngsta enheterna längst ned på ställningen.
- Om ställningen är försedd med stabiliseringsdon skall dessa monteras fast innan enheten installeras eller underhålls på ställningen.

Grounded Equipment Warning



WARNING: This device must be properly grounded at all times. Follow the instructions in this guide to properly ground the device to earth.

Waarschuwing Dit apparaat moet altijd goed geaard zijn. Volg de instructies in deze gids om het apparaat goed te aarden.

Varoitus Laitteen on oltava pysyvästi maadoitettu. Maadoita laite asianmukaisesti noudattamalla tämän oppaan ohjeita.

Avertissement L'appareil doit être correctement mis à la terre à tout moment. Suivez les instructions de ce guide pour correctement mettre l'appareil à la terre.

Warnung Das Gerät muss immer ordnungsgemäß geerdet sein. Befolgen Sie die Anweisungen in dieser Anleitung, um das Gerät ordnungsgemäß zu erden.

Avvertenza Questo dispositivo deve sempre disporre di una connessione a massa. Seguire le istruzioni indicate in questa guida per connettere correttamente il dispositivo a massa.

Advarsel Denne enheten på jordes skikkelig hele tiden. Følg instruksjonene i denne veiledningen for å jorde enheten.

Aviso Este equipamento deverá estar ligado à terra. Siga las instrucciones en esta guía para conectar correctamente este dispositivo a tierra.

¡Atención! Este dispositivo debe estar correctamente conectado a tierra en todo momento. Siga las instrucciones en esta guía para conectar correctamente este dispositivo a tierra.

Varning! Den här enheten måste vara ordentligt jordad. Följ instruktionerna i den här guiden för att jorda enheten ordentligt.

Laser and LED Safety Guidelines and Warnings

IN THIS SECTION

- [General Laser Safety Guidelines | 94](#)
- [Class 1 Laser Product Warning | 94](#)
- [Class 1 LED Product Warning | 95](#)
- [Laser Beam Warning | 95](#)

Juniper Networks devices are equipped with laser transmitters, which are considered a Class 1 Laser Product by the U.S. Food and Drug Administration and are evaluated as a Class 1 Laser Product per IEC/EN 60825-1 requirements.

Observe the following guidelines and warnings:

General Laser Safety Guidelines

When working around ports that support optical transceivers, observe the following safety guidelines to prevent eye injury:

- Do not look into unterminated ports or at fibers that connect to unknown sources.
- Do not examine unterminated optical ports with optical instruments.
- Avoid direct exposure to the beam.



LASER WARNING: Unterminated optical connectors can emit invisible laser radiation. The lens in the human eye focuses all the laser power on the retina, so focusing the eye directly on a laser source—even a low-power laser—could permanently damage the eye.

Avertissement Les connecteurs à fibre optique sans terminaison peuvent émettre un rayonnement laser invisible. Le cristallin de l'œil humain faisant converger toute la puissance du laser sur la rétine, toute focalisation directe de l'œil sur une source laser, —même de faible puissance—, peut entraîner des lésions oculaires irréversibles.

Class 1 Laser Product Warning



LASER WARNING: Class 1 laser product.

Waarschuwing Klasse-1 laser produkt.

Varoitus Luokan 1 lasertuote.

Avertissement Produit laser de classe I.

Warnung Laserprodukt der Klasse 1.

Avvertenza Prodotto laser di Classe 1.

Advarsel Laserprodukt av klasse 1.

Aviso Produto laser de classe 1.

¡Atención! Producto láser Clase I.

Varning! Laserprodukt av klass 1.

Class 1 LED Product Warning



LASER WARNING: Class 1 LED product.

Waarschuwing Klasse 1 LED-product.

Varoitus Luokan 1 valodiodituote.

Avertissement Alarme de produit LED Class I.

Warnung Class 1 LED-Produktwarnung.

Avvertenza Avvertenza prodotto LED di Classe 1.

Advarel LED-produkt i klasse 1.

Aviso Produto de classe 1 com LED.

¡Atención! Aviso sobre producto LED de Clase 1.

Varning! Lysdiodprodukt av klass 1.

Laser Beam Warning



LASER WARNING: Do not stare into the laser beam or view it directly with optical instruments.

Waarschuwing Niet in de straal staren of hem rechtstreeks bekijken met optische instrumenten.

Varoitus Älä katso säteeseen äläkä tarkastele sitä suoraan optisen laitteen avulla.

Avertissement Ne pas fixer le faisceau des yeux, ni l'observer directement à l'aide d'instruments optiques.

Warnung Nicht direkt in den Strahl blicken und ihn nicht direkt mit optischen Geräten prüfen.

Avvertenza Non fissare il raggio con gli occhi né usare strumenti ottici per osservarlo direttamente.

Advarel Stirr eller se ikke direkte p strlen med optiske instrumenter.

Aviso Não olhe fixamente para o raio, nem olhe para ele directamente com instrumentos ópticos.

¡Atención! No mirar fijamente el haz ni observarlo directamente con instrumentos ópticos.

Warning! Rikta inte blicken in mot strålen och titta inte direkt på den genom optiska instrument.

Radiation from Open Port Apertures Warning



LASER WARNING: Because invisible radiation might be emitted from the aperture of the port when no fiber cable is connected, avoid exposure to radiation and do not stare into open apertures.

Waarschuwing Aangezien onzichtbare straling vanuit de opening van de poort kan komen als er geen fiberkabel aangesloten is, dient blootstelling aan straling en het kijken in open openingen vermeden te worden.

Varoitus Koska portin aukosta voi emittoitua näkymätöntä säteilyä, kun kuitukaapelia ei ole kytkettyä, vältä säteilylle altistumista äläkä katso avoimiin aukkoihin.

Avertissement Des radiations invisibles à l'il nu pouvant traverser l'ouverture du port lorsqu'aucun câble en fibre optique n'y est connecté, il est recommandé de ne pas regarder fixement l'intérieur de ces ouvertures.

Warnung Aus der Port-Öffnung können unsichtbare Strahlen emittieren, wenn kein Glasfaserkabel angeschlossen ist. Vermeiden Sie es, sich den Strahlungen auszusetzen, und starren Sie nicht in die Öffnungen!

Avvertenza Quando i cavi in fibra non sono inseriti, radiazioni invisibili possono essere emesse attraverso l'apertura della porta. Evitate di esporvi alle radiazioni e non guardate direttamente nelle aperture.

Advarsel Unngå utsettelse for stråling, og stirr ikke inn i åpninger som er åpne, fordi usynlig stråling kan emitteres fra portens åpning når det ikke er tilkoblet en fiberkabel.

Aviso Dada a possibilidade de emissão de radiação invisível através do orifício da via de acesso, quando esta não tiver nenhum cabo de fibra conectado, deverá evitar an

EXposição à radiação e não deverá olhar fixamente para orifícios que se encontrarem a descoberto.

¡Atención! Debido a que la apertura del puerto puede emitir radiación invisible cuando no existe un cable de fibra conectado, evite mirar directamente a las aperturas para no exponerse a la radiación.

Varning! Osynlig strålning kan avges från en portöppning utan ansluten fiberkabel och du bör därför undvika att bli utsatt för strålning genom att inte stirra in i oskyddade öppningar.

Maintenance and Operational Safety Guidelines and Warnings

IN THIS SECTION

- [Battery Handling Warning | 97](#)
- [Jewelry Removal Warning | 99](#)
- [Lightning Activity Warning | 100](#)
- [Operating Temperature Warning | 101](#)
- [Product Disposal Warning | 102](#)

While performing the maintenance activities for devices, observe the following guidelines and warnings:

Battery Handling Warning



WARNING: Replacing a battery incorrectly might result in an explosion. Replace a battery only with the same or equivalent type recommended by the manufacturer. Dispose of used batteries according to the manufacturer's instructions.

Waarschuwing Er is ontploffingsgevaar als de batterij verkeerd vervangen wordt. Vervang de batterij slechts met hetzelfde of een equivalent type dat door de fabrikant aanbevolen is. Gebruikte batterijen dienen overeenkomstig fabrieksvoorschriften weggeworpen te worden.

Varoitus Räjähdyksen vaara, jos akku on vaihdettu väärään akkuun. Käytä vaihtamiseen ainoastaan saman- tai vastaavantyyppistä akkua, joka on valmistajan suosittama. Hävitä käytetyt akut valmistajan ohjeiden mukaan.

Avertissement Danger d'explosion si la pile n'est pas remplacée correctement. Ne la remplacer que par une pile de type semblable ou équivalent, recommandée par le fabricant. Jeter les piles usagées conformément aux instructions du fabricant.

Warnung Bei Einsetzen einer falschen Batterie besteht Explosionsgefahr. Ersetzen Sie die Batterie nur durch den gleichen oder vom Hersteller empfohlenen Batterietyp. Entsorgen Sie die benutzten Batterien nach den Anweisungen des Herstellers.

Advarsel Det kan være fare for eksplosjon hvis batteriet skiftes på feil måte. Skift kun med samme eller tilsvarende type som er anbefalt av produsenten. Kasser brukte batterier i henhold til produsentens instruksjoner.

Avvertenza Pericolo di esplosione se la batteria non è installata correttamente. Sostituire solo con una di tipo uguale o equivalente, consigliata dal produttore. Eliminare le batterie usate secondo le istruzioni del produttore.

Aviso Existe perigo de explosão se a bateria for substituída incorrectamente. Substitua a bateria por uma bateria igual ou de um tipo equivalente recomendado pelo fabricante. Destrua as baterias usadas conforme as instruções do fabricante.

¡Atención! Existe peligro de explosión si la batería se reemplaza de manera incorrecta. Reemplazar la batería EXclusivamente con el mismo tipo o el equivalente recomendado por el fabricante. Desechar las baterías gastadas según las instrucciones del fabricante.

Varning! Explosionsfara vid felaktigt batteribyte. Ersätt endast batteriet med samma batterityp som rekommenderas av tillverkaren eller motsvarande. Följ tillverkarens anvisningar vid kassering av använda batterier.

Jewelry Removal Warning



WARNING: Before working on equipment that is connected to power lines, remove jewelry, including rings, necklaces, and watches. Metal objects heat up when connected to power and ground and can cause serious burns or can be welded to the terminals.

Waarschuwing Alvorens aan apparatuur te werken die met elektrische leidingen is verbonden, sieraden (inclusief ringen, kettingen en horloges) verwijderen. Metalen voorwerpen worden warm wanneer ze met stroom en aarde zijn verbonden, en kunnen ernstige brandwonden veroorzaken of het metalen voorwerp aan de aansluitklemmen lassen.

Varoitus Ennen kuin työskentelet voimavirtajohtoihin kytkettyjen laitteiden parissa, ota pois kaikki korut (sormukset, kaulakorut ja kellot mukaan lukien). Metalliesineet kuumenevat, kun ne ovat yhteydessä sähkövirran ja maan kanssa, ja ne voivat aiheuttaa vakavia palovammoja tai hitsata metalliesineet kiinni liitäntänapoihin.

Avertissement Avant d'accéder à cet équipement connecté aux lignes électriques, ôter tout bijou (anneaux, colliers et montres compris). Lorsqu'ils sont branchés à l'alimentation et reliés à la terre, les objets métalliques chauffent, ce qui peut provoquer des blessures graves ou souder l'objet métallique aux bornes.

Warnung Vor der Arbeit an Geräten, die an das Netz angeschlossen sind, jeglichen Schmuck (einschließlich Ringe, Ketten und Uhren) abnehmen. Metallgegenstände erhitzen sich, wenn sie an das Netz und die Erde angeschlossen werden, und können schwere Verbrennungen verursachen oder an die Anschlußklemmen angeschweißt werden.

Avvertenza Prima di intervenire su apparecchiature collegate alle linee di alimentazione, togliersi qualsiasi monile (inclusi anelli, collane, braccialetti ed orologi). Gli oggetti metallici si riscaldano quando sono collegati tra punti di alimentazione e massa: possono causare ustioni gravi oppure il metallo può saldarsi ai terminali.

Advarsel Fjern alle smykker (inkludert ringe, halskjeder og klokke) før du skal arbeide på utstyr som er koblet til kraftledninger. Metallgjenstander som er koblet til kraftledninger og jord blir svært varme og kan forårsake alvorlige brannskader eller smelte fast til polene.

Aviso Antes de trabalhar em equipamento que esteja ligado a linhas de corrente, retire todas as jóias que estiver a usar (incluindo anéis, fios e relógios). Os objectos metálicos aquecerão em contacto com a corrente e em contacto com a ligação à terra, podendo causar queimaduras graves ou ficarem soldados aos terminais.

¡Atención! Antes de operar sobre equipos conectados a líneas de alimentación, quitarse las joyas (incluidos anillos, collares y relojes). Los objetos de metal se calientan cuando se conectan a la alimentación y a tierra, lo que puede ocasionar quemaduras graves o que los objetos metálicos queden soldados a los bornes.

Varning! Tag av alla smycken (inklusive ringar, halsband och armbandsur) innan du arbetar på utrustning som är kopplad till kraftledningar. Metallobjekt hettas upp när de kopplas ihop med ström och jord och kan förorsaka allvarliga brännskador; metallobjekt kan också sammansvetsas med kontakterna.

Lightning Activity Warning



WARNING: Do not work on the system or connect or disconnect cables during periods of lightning activity.

Waarschuwing Tijdens onweer dat gepaard gaat met bliksem, dient u niet aan het systeem te werken of kabels aan te sluiten of te ontkoppelen.

Varoitus Älä työskentele järjestelmän parissa äläkä yhdistä tai irrota kaapeleita ukkosilmalla.

Avertissement Ne pas travailler sur le système ni brancher ou débrancher les câbles pendant un orage.

Warnung Arbeiten Sie nicht am System und schließen Sie keine Kabel an bzw. trennen Sie keine ab, wenn es gewittert.

Avvertenza Non lavorare sul sistema o collegare oppure scollegare i cavi durante un temporale con fulmini.

Advarsel Utfør aldri arbeid på systemet, eller koble kabler til eller fra systemet når det tordner eller lyner.

Aviso Não trabalhe no sistema ou ligue e desligue cabos durante períodos de mau tempo (trovoada).

¡Atención! No operar el sistema ni conectar o desconectar cables durante el transcurso de descargas eléctricas en la atmósfera.

Varning! Vid åska skall du aldrig utföra arbete på systemet eller ansluta eller koppla loss kablar.

Operating Temperature Warning



WARNING: To prevent the device from overheating, do not operate it in an area that exceeds the maximum recommended ambient temperature. To prevent airflow restriction, allow at least 6 in. (15.2 cm) of clearance around the ventilation openings.

Waarschuwing Om te voorkomen dat welke switch van de Juniper Networks router dan ook oververhit raakt, dient u deze niet te bedienen op een plaats waar de maximale aanbevolen omgevingstemperatuur van 40° C wordt overschreden. Om te voorkomen dat de luchtstroom wordt beperkt, dient er minstens 15,2 cm speling rond de ventilatie-openingen te zijn.

Varoitus Ettei Juniper Networks switch-sarjan reititin ylikuumentuisi, sitä ei saa käyttää tilassa, jonka lämpötila ylittää korkeimman suositellun ympäristölämpötilan 40° C. Ettei ilmanvaihto estyisi, tuuletusaukkojen ympärille on jätettävä ainakin 15,2 cm tilaa.

Avertissement Pour éviter toute surchauffe des routeurs de la gamme Juniper Networks switch, ne l'utilisez pas dans une zone où la température ambiante est supérieure à 40° C. Pour permettre un flot d'air constant, dégagez un espace d'au moins 15,2 cm autour des ouvertures de ventilations.

Warnung Um einen Router der switch vor Überhitzung zu schützen, darf dieser nicht in einer Gegend betrieben werden, in der die Umgebungstemperatur das empfohlene Maximum von 40° C überschreitet. Um Lüftungsverschluß zu verhindern, achten Sie darauf, daß mindestens 15,2 cm lichter Raum um die Lüftungsöffnungen herum frei bleibt.

Avvertenza Per evitare il surriscaldamento dei switch, non adoperateli in un locale che ecceda la temperatura ambientale massima di 40° C. Per evitare che la circolazione dell'aria sia impedita, lasciate uno spazio di almeno 15.2 cm di fronte alle aperture delle ventole.

Advarsel Unngå overoppheting av eventuelle rutere i Juniper Networks switch Disse skal ikke brukes på steder der den anbefalte maksimale omgivelsestemperaturen overstiger 40° C (104° F). Sørg for at klaringen rundt lufteåpningene er minst 15,2 cm (6 tommer) for å forhindre nedsatt luftsirkulasjon.

Aviso Para evitar o sobreaquecimento do encaminhador Juniper Networks switch, não utilize este equipamento numa área que exceda a temperatura máxima recomendada de 40° C. Para evitar a restrição à circulação de ar, deixe pelo menos um espaço de 15,2 cm à volta das aberturas de ventilação.

¡Atención! Para impedir que un encaminador de la serie Juniper Networks switch se recaliente, no lo haga funcionar en un área en la que se supere la temperatura ambiente máxima recomendada de 40° C. Para impedir la restricción de la entrada de aire, deje un espacio mínimo de 15,2 cm alrededor de las aperturas para ventilación.

Varning! Förhindra att en Juniper Networks switch överhettas genom att inte använda den i ett område där den maximalt rekommenderade omgivningstemperaturen på 40° C överskrids. Förhindra att luftcirkulationen inskränks genom att se till att det finns fritt utrymme på minst 15,2 cm omkring ventilationsöppningarna.

Product Disposal Warning



WARNING: Disposal of this device must be handled according to all national laws and regulations.

Waarschuwing Dit produkt dient volgens alle landelijke wetten en voorschriften te worden afgedankt.

Varoitus Tämän tuotteen lopullisesta hävittämisestä tulee huolehtia kaikkia valtakunnallisia lakeja ja säännöksiä noudattaen.

Avertissement La mise au rebut définitive de ce produit doit être effectuée conformément à toutes les lois et réglementations en vigueur.

Warnung Dieses Produkt muß den geltenden Gesetzen und Vorschriften entsprechend entsorgt werden.

Avvertenza L'eliminazione finale di questo prodotto deve essere eseguita osservando le normative italiane vigenti in materia

Advarsel Endelig disponering av dette produktet må skje i henhold til nasjonale lover og forskrifter.

Aviso A descartagem final deste produto deverá ser efectuada de acordo com os regulamentos e a legislação nacional.

¡Atención! El desecho final de este producto debe realizarse según todas las leyes y regulaciones nacionales

Varning! Slutlig kassering av denna produkt bör skötas i enlighet med landets alla lagar och föreskrifter.

General Electrical Safety Guidelines and Warnings



WARNING: Certain ports on the device are designed for use as intrabuilding (within-the-building) interfaces only (Type 2 or Type 4 ports as described in *GR-1089-CORE*) and require isolation from the exposed outside plant (OSP) cabling. To comply with NEBS (Network Equipment-Building System) requirements and protect against lightning surges and commercial power disturbances, the intrabuilding ports *must not* be metallicly connected to interfaces that connect to the OSP or its wiring. The intrabuilding ports on the device are suitable for connection to intrabuilding or unexposed wiring or cabling only. The addition of primary protectors is not sufficient protection for connecting these interfaces metallicly to OSP wiring.

Avertissement Certains ports de l'appareil sont destinés à un usage en intérieur uniquement (ports Type 2 ou Type 4 tels que décrits dans le document *GR-1089-CORE*) et doivent être isolés du câblage de l'installation extérieure exposée. Pour respecter les exigences NEBS et assurer une protection contre la foudre et les perturbations de tension secteur, les ports pour intérieur *ne doivent pas* être raccordés physiquement aux interfaces prévues pour la connexion à l'installation extérieure ou à son câblage. Les ports pour intérieur de l'appareil sont réservés au raccordement de câbles pour intérieur ou non exposés uniquement. L'ajout de protections ne constitue pas une précaution suffisante pour raccorder physiquement ces interfaces au câblage de l'installation extérieure.



CAUTION: Before removing or installing components of a device, connect an electrostatic discharge (ESD) grounding strap to an ESD point and wrap and fasten the other end of the strap around your bare wrist. Failure to use an ESD grounding strap could result in damage to the device.

Attention Avant de retirer ou d'installer des composants d'un appareil, raccordez un bracelet antistatique à un point de décharge électrostatique et fixez le bracelet à votre poignet nu. L'absence de port d'un bracelet antistatique pourrait provoquer des dégâts sur l'appareil.

- Install the device in compliance with the following local, national, and international electrical codes:
 - United States—National Fire Protection Association (NFPA 70), United States National Electrical Code.
 - Other countries—International Electromechanical Commission (IEC) 60364, Part 1 through Part 7.
 - Evaluated to the TN power system.

- Canada—Canadian Electrical Code, Part 1, CSA C22.1.
- Suitable for installation in Information Technology Rooms in accordance with Article 645 of the National Electrical Code and NFPA 75.

Peut être installé dans des salles de matériel de traitement de l'information conformément à l'article 645 du National Electrical Code et à la NFPA 75.

- Locate the emergency power-off switch for the room in which you are working so that if an electrical accident occurs, you can quickly turn off the power.
- Make sure that you clean grounding surface and give them a bright finish before making grounding connections.
- Do not work alone if potentially hazardous conditions exist anywhere in your workspace.
- Never assume that power is disconnected from a circuit. Always check the circuit before starting to work.
- Carefully look for possible hazards in your work area, such as moist floors, ungrounded power extension cords, and missing safety grounds.
- Operate the device within marked electrical ratings and product usage instructions.
- To ensure that the device and peripheral equipment function safely and correctly, use the cables and connectors specified for the attached peripheral equipment, and make certain they are in good condition.

You can remove and replace many device components without powering off or disconnecting power to the device, as detailed elsewhere in the hardware documentation for this device. Never install equipment that appears to be damaged.

Prevention of Electrostatic Discharge Damage

Device components that are shipped in antistatic bags are sensitive to damage from static electricity. Some components can be impaired by voltages as low as 30 V. You can easily generate potentially damaging static voltages whenever you handle plastic or foam packing material or if you move components across plastic or carpets. Observe the following guidelines to minimize the potential for electrostatic discharge (ESD) damage, which can cause intermittent or complete component failures:

- Always use an ESD wrist strap when you are handling components that are subject to ESD damage, and make sure that it is in direct contact with your skin.

If a grounding strap is not available, hold the component in its antistatic bag (see [Figure 21 on page 105](#)) in one hand and touch the exposed, bare metal of the device with the other hand immediately before inserting the component into the device.



WARNING: For safety, periodically check the resistance value of the ESD grounding strap. The measurement must be in the range 1 through 10 Mohms.

Avertissement Par mesure de sécurité, vérifiez régulièrement la résistance du bracelet antistatique. Cette valeur doit être comprise entre 1 et 10 mégohms (Mohms).

- When handling any component that is subject to ESD damage and that is removed from the device, make sure the equipment end of your ESD wrist strap is attached to the ESD point on the chassis.

If no grounding strap is available, touch the exposed, bare metal of the device to ground yourself before handling the component.

- Avoid contact between the component that is subject to ESD damage and your clothing. ESD voltages emitted from clothing can damage components.
- When removing or installing a component that is subject to ESD damage, always place it component-side up on an antistatic surface, in an antistatic card rack, or in an antistatic bag (see [Figure 21 on page 105](#)). If you are returning a component, place it in an antistatic bag before packing it.

Figure 21: Placing a Component into an Antistatic Bag

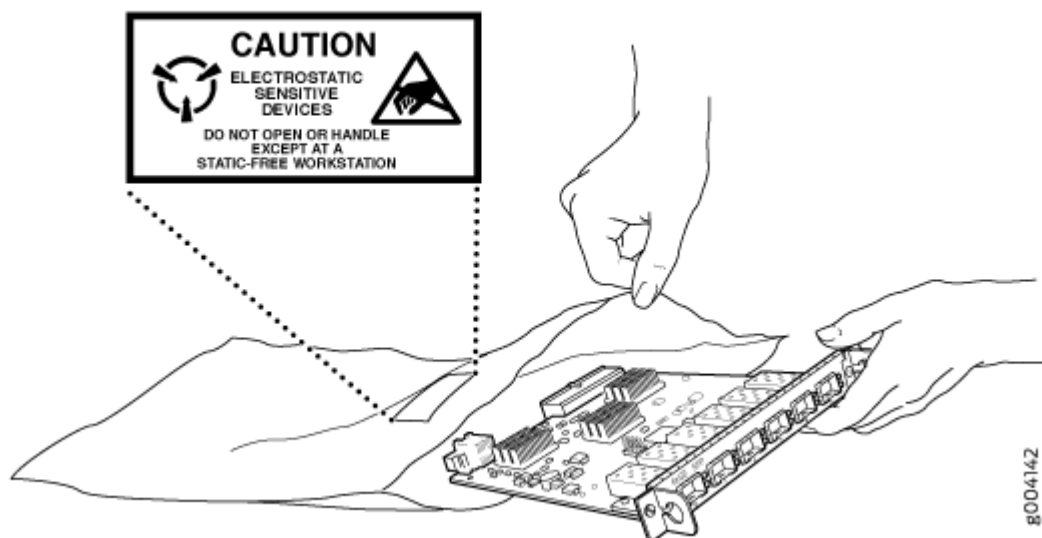



CAUTION: ANSI/TIA/EIA-568 cables such as Category 5e and Category 6 can get electrostatically charged. To dissipate this charge, always ground the cables to a suitable and safe earth ground before connecting them to the system.

Attention Les câbles ANSI/TIA/EIA-568, par exemple Cat 5e et Cat 6, peuvent emmagasiner des charges électrostatiques. Pour évacuer ces charges, reliez toujours les câbles à une prise de terre adaptée avant de les raccorder au système.

AC Power Electrical Safety Guidelines

The following electrical safety guidelines apply to AC-powered devices:

- Note the following warnings printed on the device:

“CAUTION: THIS UNIT HAS MORE THAN ONE POWER SUPPLY CORD. DISCONNECT ALL POWER SUPPLY CORDS BEFORE SERVICING TO AVOID ELECTRIC SHOCK.”

“ATTENTION: CET APPAREIL COMPORTE PLUS D'UN CORDON D'ALIMENTATION. AFIN DE PRÉVENIR LES CHOCS ÉLECTRIQUES, DÉBRANCHER TOUT CORDON D'ALIMENTATION AVANT DE FAIRE LE DÉPANNAGE.”

- AC-powered devices are shipped with a three-wire electrical cord with a grounding-type plug that fits only a grounding-type power outlet. Do not circumvent this safety feature. Equipment grounding must comply with local and national electrical codes.
- You must provide an external certified circuit breaker (2-pole circuit breaker or 4-pole circuit breaker based on your device) rated minimum 20 A in the building installation.
- The power cord serves as the main disconnecting device for the AC-powered device. The socket outlet must be near the AC-powered device and be easily accessible.
- For devices that have more than one power supply connection, you must ensure that all power connections are fully disconnected so that power to the device is completely removed to prevent electric shock. To disconnect power, unplug all power cords (one for each power supply).

Power Cable Warning (Japanese)

WARNING: The attached power cable is only for this product. Do not use the cable for another product.

注意

附属の電源コードセットはこの製品専用です。
他の電気機器には使用しないでください。

0477083

AC Power Disconnection Warning



WARNING: Before working on the device or near power supplies, unplug all the power cords from an AC-powered device.

Waarschuwing Voordat u aan een frame of in de nabijheid van voedingen werkt, dient u bij wisselstroom toestellen de stekker van het netsnoer uit het stopcontact te halen.

Varoitus Kytke irti vaihtovirtalaitteiden virtajohto, ennen kuin teet mitään asennuspohjalle tai työskentelet virtalähteiden läheisyydessä.

Avertissement Avant de travailler sur un châssis ou à proximité d'une alimentation électrique, débrancher le cordon d'alimentation des unités en courant alternatif.

Warnung Bevor Sie an einem Chassis oder in der Nähe von Netzgeräten arbeiten, ziehen Sie bei Wechselstromeinheiten das Netzkabel ab bzw.

Avvertenza Prima di lavorare su un telaio o intorno ad alimentatori, scollegare il cavo di alimentazione sulle unità CA.

Advarsel Før det utføres arbeid på kabinettet eller det arbeides i nærheten av strømforsyningsenheter, skal strømledningen trekkes ut på vekselstrømsenheter.

Aviso Antes de trabalhar num chassis, ou antes de trabalhar perto de unidades de fornecimento de energia, desligue o cabo de alimentação nas unidades de corrente alternada.

¡Atención! Antes de manipular el chasis de un equipo o trabajar cerca de una fuente de alimentación, desenchufar el cable de alimentación en los equipos de corriente alterna (CA).

Warning! Innan du arbetar med ett chassi eller nära strömförsörjningsenheter skall du för växelströmsenheter dra ur nätsladden.

DC Power Disconnection Warning



WARNING: Before performing any of the DC power procedures, ensure that power is removed from the DC circuit. To ensure that all power is off, locate the circuit breaker on the panel board that services the DC circuit, switch the circuit breaker to the OFF position, and tape the device handle of the circuit breaker in the OFF position.

Waarschuwing Voordat u een van de onderstaande procedures uitvoert, dient u te controleren of de stroom naar het gelijkstroom circuit uitgeschakeld is. Om u ervan te verzekeren dat alle stroom UIT is geschakeld, kiest u op het schakelbord de stroomverbreker die het gelijkstroom circuit bedient, draait de stroomverbreker naar de UIT positie en plakt de schakelaarhendel van de stroomverbreker met plakband in de UIT positie vast.

Varoitus Varmista, että tasavirtapiirissä ei ole virtaa ennen seuraavien toimenpiteiden suorittamista. Varmistaaksesi, että virta on KATKAISTU täysin, paikanna tasavirrasta huolehtivassa kojetaulussa sijaitseva suojakytkin, käännä suojakytkin KATKAISTU-asentoon ja teippaa suojakytkimen varsi niin, että se pysyy KATKAISTU-asennossa.

Avertissement Avant de pratiquer l'une quelconque des procédures ci-dessous, vérifier que le circuit en courant continu n'est plus sous tension. Pour en être sûr, localiser le disjoncteur situé sur le panneau de service du circuit en courant continu, placer le disjoncteur en position fermée (OFF) et, à l'aide d'un ruban adhésif, bloquer la poignée du disjoncteur en position OFF.

Warnung Vor Ausführung der folgenden Vorgänge ist sicherzustellen, daß die Gleichstromschaltung keinen Strom erhält. Um sicherzustellen, daß sämtlicher Strom abgestellt ist, machen Sie auf der Schalttafel den Unterbrecher für die Gleichstromschaltung ausfindig, stellen Sie den Unterbrecher auf AUS, und kleben Sie den Schaltergriff des Unterbrechers mit Klebeband in der AUS-Stellung fest.

Avvertenza Prima di svolgere una qualsiasi delle procedure seguenti, verificare che il circuito CC non sia alimentato. Per verificare che tutta l'alimentazione sia scollegata (OFF), individuare l'interruttore automatico sul quadro strumenti che alimenta il circuito CC, mettere l'interruttore in posizione OFF e fissarlo con nastro adesivo in tale posizione.

Advarsel Før noen av disse prosedyrene utføres, kontroller at strømmen er frakoblet likestrømkretsen. Sørg for at all strøm er slått AV. Dette gjøres ved å lokalisere strømbryteren på brytertavlen som betjener likestrømkretsen, slå strømbryteren AV og teipe bryterhåndtaket på strømbryteren i AV-stilling.

Aviso Antes de executar um dos seguintes procedimentos, certifique-se que desligou a fonte de alimentação de energia do circuito de corrente contínua. Para se assegurar que toda a corrente foi DESLIGADA, localize o disjuntor no painel que serve o circuito de corrente contínua e coloque-o na posição OFF (Desligado), segurando nessa posição a manivela do interruptor do disjuntor com fita isoladora.

¡Atención! Antes de proceder con los siguientes pasos, comprobar que la alimentación del circuito de corriente continua (CC) esté cortada (OFF). Para asegurarse de que toda la alimentación esté cortada (OFF), localizar el interruptor automático en el panel que alimenta al circuito de corriente continua, cambiar el interruptor automático a la posición de Apagado (OFF), y sujetar con cinta la palanca del interruptor automático en posición de Apagado (OFF).

Varning! Innan du utför någon av följande procedurer måste du kontrollera att strömförsörjningen till likströmskretsen är bruten. Kontrollera att all strömförsörjning är BRUTEN genom att slå AV det överspänningsskydd som skyddar likströmskretsen och tejpa fast överspänningsskyddets omkopplare i FRÅN-läget.

DC Power Grounding Requirements and Warning

An insulated grounding conductor that is identical in size to the grounded and ungrounded branch circuit supply conductors but is identifiable by green and yellow stripes is installed as part of the branch circuit that supplies the device. The grounding conductor is a separately derived system at the supply transformer or motor generator set.



WARNING: When you install the device, the ground connection must always be made first and disconnected last.

Waarschuwing Bij de installatie van het toestel moet de aardverbinding altijd het eerste worden gemaakt en het laatste worden losgemaakt.

Varoitus Laitetta asennettaessa on maahan yhdistäminen aina tehtävä ensiksi ja maadoituksen irti kytkeminen viimeiseksi.

Avertissement Lors de l'installation de l'appareil, la mise à la terre doit toujours être connectée en premier et déconnectée en dernier.

Warnung Der Erdanschluß muß bei der Installation der Einheit immer zuerst hergestellt und zuletzt abgetrennt werden.

Avvertenza In fase di installazione dell'unità, eseguire sempre per primo il collegamento a massa e disconnetterlo per ultimo.

Advarsel Når enheten installeres, må jordledningen alltid tilkobles først og frakobles sist.

Aviso Ao instalar a unidade, a ligação à terra deverá ser sempre a primeira a ser ligada, e a última a ser desligada.

¡Atención! Al instalar el equipo, conectar la tierra la primera y desconectarla la última.

Varning! Vid installation av enheten måste jordledningen alltid anslutas först och kopplas bort sist.

DC Power Wiring Sequence Warning



WARNING: Wire the DC power supply using the appropriate lugs. When connecting power, the proper wiring sequence is ground to ground, +RTN to +RTN, then -48 V to -48 V. When disconnecting power, the proper wiring sequence is -48 V to -48 V, +RTN to +RTN, then ground to ground. Note that the ground wire must always be connected first and disconnected last.

Waarschuwing De juiste bedradingsvolgorde verbonden is aarde naar aarde, +RTN naar +RTN, en -48 V naar -48 V. De juiste bedradingsvolgorde losgemaakt is en -48 naar -48 V, +RTN naar +RTN, aarde naar aarde.

Varoitus Oikea yhdistettävä kytkentäjärjestys on maajohto maajohtoon, +RTN varten +RTN, -48 V varten -48 V. Oikea irrotettava kytkentäjärjestys on -48 V varten -48 V, +RTN varten +RTN, maajohto maajohtoon.

Avertissement Câblez l'alimentation d'alimentation CC En utilisant les crochets appropriés à l'extrémité de câblage. En reliant la puissance, l'ordre approprié de câblage est rectifié pour rectifier, +RTN à +RTN, puis -48 V à -48 V. En débranchant la puissance, l'ordre approprié de câblage est -48 V à -48 V, +RTN à +RTN, a alors rectifié pour rectifier. Notez que le fil de masse devrait toujours être relié d'abord et débranché pour la dernière fois. Notez que le fil de masse devrait toujours être relié d'abord et débranché pour la dernière fois.

Warnung Die Stromzufuhr ist nur mit geeigneten Ringösen an das DC Netzteil anzuschliessen. Die richtige Anschlusssequenz ist: Erdanschluss zu Erdanschluss, +RTN zu +RTN und dann -48V zu -48V. Die richtige Sequenz zum Abtrennen der Stromversorgung ist -48V zu -48V, +RTN zu +RTN und dann Erdanschluss zu Erdanschluss. Es ist zu beachten dass der Erdanschluss immer zuerst angeschlossen und als letztes abgetrennt wird.

Avvertenza Mostra la morsettiera dell alimentatore CC. Cablare l'alimentatore CC usando i connettori adatti all'estremità del cablaggio, come illustrato. La corretta sequenza di cablaggio è da massa a massa, da positivo a positivo (da linea ad L) e da negativo a negativo (da neutro a N). Tenere presente che il filo di massa deve sempre venire collegato per primo e scollegato per ultimo.

Advarsel Riktig tilkoples tilkoplingssekvens er jord til jord, +RTN til +RTN, -48 V til -48 V. Riktig frakoples tilkoplingssekvens er -48 V til -48 V, +RTN til +RTN, jord til jord.

Aviso Ate con alambre la fuente de potencia cc Usando los terminales apropiados en el extremo del cableado. Al conectar potencia, la secuencia apropiada del cableado se muele para moler, +RTN a +RTN, entonces -48 V a -48 V. Al desconectar potencia, la secuencia apropiada del cableado es -48 V a -48 V, +RTN a +RTN, entonces molíó para moler. Observe que el alambre de tierra se debe conectar siempre primero y desconectar por último. Observe que el alambre de tierra se debe conectar siempre primero y desconectar por último.

¡Atención! Wire a fonte de alimentação de DC Usando os talões apropriados nan Extremidade da fiação. Ao conectar a potência, a seqüência apropriada da fiação é moída para moer, +RTN a +RTN, então -48 V a -48 V. Ao desconectar a potência, a seqüência apropriada da fiação é -48 V a -48 V, +RTN a +RTN, moeu então para moer. Anote que o fio à terra deve sempre ser conectado primeiramente e desconectado por último. Anote que o fio à terra deve sempre ser conectado primeiramente e desconectado por último.

Varning! Korrekt kopplingssekvens ar jord till jord, +RTN till +RTN, -48 V till -48 V. Korrekt kopplas kopplingssekvens ar -48 V till -48 V, +RTN till +RTN, jord till jord.

DC Power Wiring Terminations Warning



WARNING: When stranded wiring is required, use approved wiring terminations, such as closed-loop or spade-type with upturned lugs. These terminations must be the appropriate size for the wires and must clamp both the insulation and conductor.

Waarschuwing Wanneer geslagen bedrading vereist is, dient u bedrading te gebruiken die voorzien is van goedgekeurde aansluitingspunten, zoals het gesloten-lus type of het grijperschop type waarbij de aansluitpunten omhoog wijzen. Deze aansluitpunten dienen de juiste maat voor de draden te hebben en dienen zowel de isolatie als de geleider vast te klemmen.

Varoitus Jos säikeellinen johdin on tarpeen, käytä hyväksyttyä johdinliitääntä, esimerkiksi suljettua silmukkaa tai kourumaista liitääntä, jossa on ylöspäin käännetty kiinnityskorvat. Tällaisten liitääntöjen tulee olla kooltaan johtimiin sopivia ja niiden tulee puristaa yhteen sekä eristeen että johdinosan.

Avertissement Quand des fils torsadés sont nécessaires, utiliser des douilles terminales homologuées telles que celles à circuit fermé ou du type à plage ouverte avec cosses rebroussées. Ces douilles terminales doivent être de la taille qui convient aux fils et doivent être refermées sur la gaine isolante et sur le conducteur.

Warnung Wenn Litzenverdrahtung erforderlich ist, sind zugelassene Verdrahtungsabschlüsse, z.B. für einen geschlossenen Regelkreis oder gabelförmig, mit nach oben gerichteten Kabelschuhen zu verwenden. Diese Abschlüsse sollten die angemessene Größe für die Drähte haben und sowohl die Isolierung als auch den Leiter festklemmen.

Avvertenza Quando occorre usare trecce, usare connettori omologati, come quelli a occhiello o a forcilla con linguette rivolte verso l'alto. I connettori devono avere la misura adatta per il cablaggio e devono serrare sia l'isolante che il conduttore.

Advarsel Hvis det er nødvendig med flertrådede ledninger, brukes godkjente ledningsavslutninger, som for eksempel lukket sløyfe eller spadetype med oppoverbøyde kabelsko. Disse avslutningene skal ha riktig størrelse i forhold til ledningene, og skal klemme sammen både isolasjonen og ledere.

Aviso Quando forem requeridas montagens de instalação eléctrica de cabo torcido, use terminações de cabo aprovadas, tais como, terminações de cabo em circuito fechado e planas com terminais de orelha voltados para cima. Estas terminações de cabo deverão ser do tamanho apropriado para os respectivos cabos, e deverão prender simultaneamente o isolamento e o fio condutor.

¡Atención! Cuando se necesite hilo trenzado, utilizar terminales para cables homologados, tales como las de tipo "bucle cerrado" o "espada", con las lengüetas de conexión vueltas hacia arriba. Estos terminales deberán ser del tamaño apropiado para los cables que se utilicen, y tendrán que sujetar tanto el aislante como el conductor.

Warning! När flertrådiga ledningar krävs måste godkända ledningskontakter användas, t.ex. kabelsko av slutet eller öppen typ med uppåtvänd tapp. Storleken på dessa kontakter måste vara avpassad till ledningarna och måste kunna hålla både isoleringen och ledaren fastklämda.

Multiple Power Supplies Disconnection Warning



WARNING: The network device has more than one power supply connection. All connections must be removed completely to remove power from the unit completely.

Waarschuwing Deze eenheid heeft meer dan één stroomtoevoerverbinding; alle verbindingen moeten volledig worden verwijderd om de stroom van deze eenheid volledig te verwijderen.

Varoitus Tässä laitteessa on useampia virtalähdekytkentöjä. Kaikki kytkennät on irrotettava kokonaan, jotta virta poistettaisiin täysin laitteesta.

Avertissement Cette unité est équipée de plusieurs raccordements d'alimentation. Pour supprimer tout courant électrique de l'unité, tous les cordons d'alimentation doivent être débranchés.

Warnung Diese Einheit verfügt über mehr als einen Stromanschluß; um Strom gänzlich von der Einheit fernzuhalten, müssen alle Stromzufuhren abgetrennt sein.

Avvertenza Questa unità ha più di una connessione per alimentatore elettrico; tutte le connessioni devono essere completamente rimosse per togliere l'elettricità dall'unità.

Advarsel Denne enheten har mer enn én strømtilkobling. Alle tilkoblinger må kobles helt fra for å eliminere strøm fra enheten.

Aviso Este dispositivo possui mais do que uma conexão de fonte de alimentação de energia; para poder remover a fonte de alimentação de energia, deverão ser desconectadas todas as conexões existentes.

¡Atención! Esta unidad tiene más de una conexión de suministros de alimentación; para eliminar la alimentación por completo, deben desconectarse completamente todas las conexiones.

Varning! Denna enhet har mer än en strömförsörjningsanslutning; alla anslutningar måste vara helt avlägsnade innan strömtillförseln till enheten är fullständigt bruten.

TN Power Warning



WARNING: The device is designed to work with a TN power system.

Waarschuwing Het apparaat is ontworpen om te functioneren met TN energiesystemen.

Varoitus Koje on suunniteltu toimimaan TN-sähkövoimajärjestelmien yhteydessä.

Avertissement Ce dispositif a été conçu pour fonctionner avec des systèmes d'alimentation TN.

Warnung Das Gerät ist für die Verwendung mit TN-Stromsystemen ausgelegt.

Avvertenza Il dispositivo è stato progettato per l'uso con sistemi di alimentazione TN.

Advarsel Utstyret er utfomet til bruk med TN-strømsystemer.

Aviso O dispositivo foi criado para operar com sistemas de corrente TN.

¡Atención! El equipo está diseñado para trabajar con sistemas de alimentación tipo TN.

Varning! Enheten är konstruerad för användning tillsammans med elkraftssystem av TN-typ.

Action to Take After an Electrical Accident

If an electrical accident results in an injury, take the following actions in this order:

1. Use caution. Be aware of potentially hazardous conditions that could cause further injury.
2. Disconnect power from the device.

3. If possible, send another person to get medical aid. Otherwise, assess the condition of the victim, and then call for help.

JRR200 Agency Approvals and Regulatory Compliance Information

IN THIS SECTION

- [Agency Approvals | 115](#)
- [Acoustic Noise Compliance Statements | 117](#)
- [EMC Requirements | 117](#)

Agency Approvals

IN THIS SECTION

- [Compliance Statement for Argentina | 117](#)

The JRR200 Route Reflector complies with the following standards:

- Safety
 - CAN/CSA C22.2 No. 60950-1-07, 2nd Edition, 2014-10
 - EN 60950-1:2006 + A11:2009 + A1:2010 + A12:2011 + A2:2013
 - EN 60825-1 Safety of Laser Products - Part 1: Equipment Classification, Requirements and User's Guide
 - EN 60825-2 Safety of Laser Products - Part 2: Safety of Optical Fiber Communication Systems
 - UL 60950-1, 2nd Edition, 2014-10-14

- CAN/CSA C22.2 No. 62368-1-14
- EN 62368-1: 2014+A11: 2017
- UL 62368-1: 2014
- IEC 62368-1:2014 (Second Edition)
- IEC 60950-1:2005 (Second Edition); Am1:2009 + Am2:2013
- CE
- EMC
 - FCC Part 15 Class A (2007) USA Radiated Emissions
 - EN 55022 Class A (2006) European Radiated Emissions
 - VCCI Class A (2007) Japanese Radiated Emissions
 - FCC 47CFR , Part 15 Class A (2009) USA Radiated Emissions
 - BSMI Class A (Taiwan)
 - EN 300 386 V1.3.3 (2005) Telecom Network Equipment— EMC requirements
 - ICES-003 Class A
 - AS/NZS CISPR 22 Class A
 - CISPR 22 Class A
- Immunity
 - EN-61000-3-2 Power Line Harmonics
 - EN-61000-3-3 Voltage Fluctuations and Flicker
 - EN-61000-4-2 ESD
 - EN-61000-4-3 Radiated Immunity
 - EN-61000-4-4 EFT
 - EN-61000-4-5 Surge
 - EN-61000-4-6 Conducted Immunity
 - EN-61000-4-11 Voltage Dips and Sags
 - EN 55024 +A1+A2 (1998) Information Technology

- 1KV / 2KV surge required (no 4KV / DT)
- ROHS
 - Reduction of Hazardous Substances (ROHS) 6
- Telco
 - Common Language Equipment Identifier (CLEI) code
- NEBS
 - Not compliant

Compliance Statement for Argentina

EQUIPO DE USO IDÓNEO.

Acoustic Noise Compliance Statements

The maximum emitted sound pressure level is 70 dB(A) or less per EN ISO 7779.

German Translation:

Maschinenlärminformations-Verordnung - 3. GPSGV, der höchste Schalldruckpegel beträgt 70 dB(A) oder weniger gemäss EN ISO 7779.

EMC Requirements

IN THIS SECTION

- [Canada | 118](#)
- [European Community | 118](#)
- [Israel | 118](#)
- [Japan | 118](#)
- [United States | 118](#)

Canada

This Class A digital apparatus complies with Canadian ICES-003.

Cet appareil numérique de la classe A est conforme à la norme NMB-003 du Canada.

European Community

This is a Class A product. In a domestic environment this product may cause radio interference in which case the user may be required to take adequate measures.

Israel

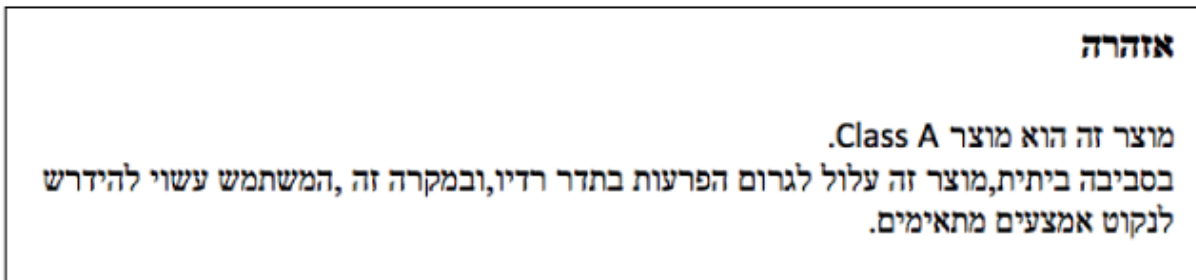

The preceding translates as follows:

This product is Class A. In residential environments, the product may cause radio interference, and in such a situation, the user may be required to take adequate measures.

Japan

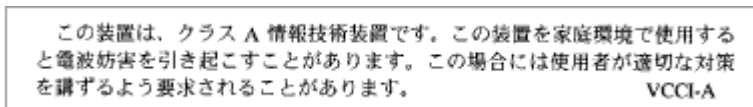

The preceding translates as follows:

This is a Class A product. In a domestic environment this product may cause radio interference in which case the user may be required to take adequate measures.

VCCI-A

United States

The JRR200 Route Reflector has been tested and found to comply with the limits for a Class A digital device of the FCC Rules. These limits are designed to provide reasonable protection against harmful

interference when the equipment is operated in a commercial environment. This equipment generates, uses, and can radiate radio frequency energy and, if not installed and used in accordance with the instruction manual, may cause harmful interference to radio communications. Operation of this equipment in a residential area is likely to cause harmful interference in which case the user will be required to correct the interference at his own expense.