

MX10003 Universal Routing Platform Hardware Guide

Published
2024-09-19

Juniper Networks, Inc.
1133 Innovation Way
Sunnyvale, California 94089
USA
408-745-2000
www.juniper.net

Juniper Networks, the Juniper Networks logo, Juniper, and Junos are registered trademarks of Juniper Networks, Inc. in the United States and other countries. All other trademarks, service marks, registered marks, or registered service marks are the property of their respective owners.

Juniper Networks assumes no responsibility for any inaccuracies in this document. Juniper Networks reserves the right to change, modify, transfer, or otherwise revise this publication without notice.

MX10003 Universal Routing Platform Hardware Guide
Copyright © 2024 Juniper Networks, Inc. All rights reserved.

The information in this document is current as of the date on the title page.

YEAR 2000 NOTICE

Juniper Networks hardware and software products are Year 2000 compliant. Junos OS has no known time-related limitations through the year 2038. However, the NTP application is known to have some difficulty in the year 2036.

END USER LICENSE AGREEMENT

The Juniper Networks product that is the subject of this technical documentation consists of (or is intended for use with) Juniper Networks software. Use of such software is subject to the terms and conditions of the End User License Agreement ("EULA") posted at <https://support.juniper.net/support/eula/>. By downloading, installing or using such software, you agree to the terms and conditions of that EULA.

Table of Contents

[About This Guide | x](#)

1

Overview

MX10003 System Overview | 2

- [Benefits of the MX10003 Router | 2](#)
- [MX10003 Router Hardware Overview | 3](#)
- [MX10003 Hardware Components and CLI Terminology | 4](#)
- [MX10003 Component Redundancy | 7](#)
- [MX10003 Field-Replaceable Units | 8](#)

MX10003 Chassis | 9

- [MX10003 Chassis Description | 10](#)
- [MX10003 Front and Rear Panel Components | 12](#)
- [MX10003 Cable Management Bracket Description | 13](#)
- [Alarm LEDs on the MX10003 Front Panel | 14](#)

MX10003 Cooling System | 16

- [MX10003 Cooling System Description | 16](#)
- [MX10003 Fan Module LED | 19](#)

MX10003 AC Power System | 20

- [MX10003 AC Power System Description | 21](#)
- [MX10003 AC Power Supply Module LEDs | 22](#)
- [MX10003 Router AC Power Specifications | 23](#)
- [AC Power Circuit Breaker Requirements for the MX10003 Router | 24](#)
- [AC Power Cord Specifications for MX10003 Routers | 24](#)

MX10003 DC Power System | 27

- [MX10003 DC Power System Description | 27](#)

- MX10003 DC Power Supply Module LEDs | 28
- MX10003 Router DC Power Specifications | 29
- DC Power Circuit Breaker Requirements for the MX10003 Router | 29
- DC Power Source Cabling for MX10003 Router | 30
- DC Power Cable Specifications for MX10003 Router | 31

MX10003 Routing and Control Board | 32

- MX10003 Routing and Control Board (RCB) Description | 32
- MX10003 RCB LEDs | 37

MX10003 Interface Modules | 38

- MX10003 MPC (Multi-Rate) | 39
- MX10003 MPC (Multi-Rate) | 42
- MX10003 Port and Interface Numbering | 44
- MX10003 MPC (Multi-Rate) LEDs | 45
- Multi-Rate Ethernet MIC LEDs | 45

2

Site Planning, Preparation, and Specifications

MX10003 Site Preparation Checklist | 48

MX10003 Site Guidelines and Requirements | 49

- MX10003 Router Environmental Specifications | 50
- MX10003 Router Grounding Specifications | 51
- MX10003 Router Clearance Requirements for Airflow and Hardware Maintenance | 53
- MX10003 Router Physical Specifications | 54
- MX10003 Router Rack Requirements | 56

MX10003 Power Planning | 58

- Calculating Power Requirements for MX10003 Router | 58

MX10003 Network Cable and Transceiver Planning | 63

- Calculating Power Budget and Power Margin for Fiber-Optic Cables | 63
 - Calculate Power Budget for Fiber-Optic Cables | 64

| How to Calculate Power Margin for Fiber-Optic Cables | 64

CB-RE and RCB Interface Cable and Wire Specifications for MX Series Routers | 66

Fiber-Optic Cable Signal Loss, Attenuation, and Dispersion | 67

MX10003 Management and Console Port Specifications and Pinouts | 68

| RJ-45 Connector Pinouts for MX Series CB-RE or RCB Auxillary and Console Ports | 69

| RJ-45 Connector Pinouts for an MX Series CB-RE or RCB Management Port | 70

3

Initial Installation and Configuration

MX10003 Installation Overview | 73

Tools and Parts Required to Unpack the MX10003 Router | 74

Unpacking the MX10003 Router | 74

Verifying the MX10003 Router Parts Received | 75

Installing the MX10003 | 78

| Tools Required to the Install MX10003 Router in a Rack | 78

| Installing the MX10003 Router in a Rack | 78

Connecting the MX10003 to Power | 81

| Tools and Parts Required for MX10003 Router Grounding and Power Connections | 82

| Grounding the MX10003 Router | 82

| Connecting Power to an AC-Powered MX10003 Router | 84

| Connecting Power to a DC-Powered MX10003 Router | 86

Connecting the MX10003 to the Network | 89

| Tools and Parts Required to Connect the MX10003 Router to External Devices | 89

| Connecting the MX10003 Router to External Devices and Cables | 90

| Connecting the Router to a Network for Out-of-Band Management | 90

| Connecting the Router to a Console Device | 91

| Connecting the Router to External Clocking and Timing Devices | 93

Powering On and Off the MX10003 | 96

| Powering On an AC-Powered MX10003 Router | 96

Powering On a DC-Powered MX10003 Router | 97

Powering Off the MX10003 Router | 99

Initially Configuring the MX10003 Router | 99

Maintaining Components

Routine Maintenance Procedures for MX10003 Routers | 105

Maintaining MX10003 Cooling System Components | 106

Maintaining the MX10003 Air Filter | 106

Replacing the MX10003 Air Filter Unit | 107

Removing the MX10003 Air Filter Unit | 107

Installing the MX10003 Air Filter Unit | 108

Replacing the MX10003 Air Filter | 109

Removing the MX10003 Air Filter | 110

Installing the MX10003 Air Filter | 111

Maintaining the MX10003 Fan Module | 112

Replacing an MX10003 Fan Module | 114

Removing an MX10003 Fan Module | 114

Installing an MX10003 Fan Module | 115

Maintaining MX10003 Power System Components | 116

Maintaining the Power Supplies | 117

Replacing an MX10003 AC Power Supply | 118

Removing an MX10003 AC Power Supply | 118

Installing an MX10003 AC Power Supply | 119

Replacing an MX10003 DC Power Supply | 121

Removing an MX10003 DC Power Supply | 121

Installing an MX10003 DC Power Supply | 123

Maintaining MX10003 Routing and Control Board | 125

Maintaining the Routing and Control Board (RCB) | 125

Replacing an MX10003 RCB | 127

Removing an MX10003 RCB | 127

| Installing an MX10003 RCB | 128

Maintaining MX10003 Interface Modules | 131

Maintaining MICs | 131

Replacing an MX10003 MIC | 132

| Removing an MX10003 MIC | 132

| Installing an MX10003 MIC | 134

Maintaining MPCs | 136

Replacing an MX10003 MPC | 138

| Removing an MX10003 MPC | 138

| Installing an MX10003 MPC | 140

Maintaining Cables That Connect to MPCs or MICs | 143

Replacing a Cable on an MX10003 MPC or MIC | 144

| Removing a Cable on an MPC or MIC | 144

| Installing a Cable on an MPC or MIC | 145

Replace an SFP, SFP+, or QSFP+ Transceiver | 147

| Remove a Transceiver | 147

| Install a Transceiver | 149

Replace a QSFP28 Transceiver | 151

| Remove a QSFP28 Transceiver | 152

| Install a QSFP28 Transceiver | 154

5

Contacting Customer Support and Returning the Chassis or Components

Contacting Customer Support and Returning the Chassis or Components | 158

Contact Customer Support to Obtain a Return Material Authorization | 158

Locating the Serial Number on a MX10003 Router or Component | 159

| Listing the Chassis and Component Details Using the CLI | 160

| Locating the Chassis Serial Number ID Label on a MX10003 | 161

| Locating the Serial Number ID Labels on MX10003 Power Supplies | 161

| Locating the Serial Number ID Label on MX10003 Fan Module | 162

| Locating the Serial Number ID Labels on MX10003 Line Cards | 162

| Locating the Serial Number ID Labels on MX10003 Routing and Control Board (RCB) | 163

| Locating the Serial Number ID Label on a MX10003 SATA SSD | 164

Guidelines for Packing Hardware Components for Shipment | 164

6

Safety and Compliance Information

Definitions of Safety Warning Levels | 168

General Safety Guidelines and Warnings | 169

General Safety Warnings for Juniper Networks Devices | 171

Prevention of Electrostatic Discharge Damage | 173

Fire Safety Requirements | 175

Installation Instructions Warning | 176

Chassis and Component Lifting Guidelines | 177

Ramp Warning | 178

Rack-Mounting and Cabinet-Mounting Warnings | 178

Laser and LED Safety Guidelines and Warnings | 182

Radiation from Open Port Apertures Warning | 185

Maintenance and Operational Safety Guidelines and Warnings | 186

General Electrical Safety Guidelines and Warnings | 192

Prevention of Electrostatic Discharge Damage | 193

Site Electrical Wiring Guidelines | 195

AC Power Electrical Safety Guidelines | 196

AC Power Disconnection Warning | 197

DC Power Disconnection Warning | 198

DC Power Grounding Requirements and Warning | 199

DC Power Wiring Sequence Warning | 200

DC Power Wiring Terminations Warning | 202

Multiple Power Supplies Disconnection Warning | 203

TN Power Warning | 204

Action to Take After an Electrical Accident | 204

Agency Approvals for MX10003 Router | 205

Compliance Statements for Data Center | 207

Compliance Statements for EMC Requirements | 207

Compliance Statements for Environmental Requirements | 209

Compliance Statements for Acoustic Noise for MX10003 Router | 209

Statements of Volatility for Juniper Network Devices | 209

About This Guide

Use this guide to install hardware and perform initial software configuration, routine maintenance, and troubleshooting for the MX10003 Universal Routing Platform. After completing the installation and basic configuration procedures covered in this guide, refer to the Junos OS documentation for information about further software configuration.

RELATED DOCUMENTATION

[MX10003 Quick Start](#)

[Junos OS for MX Series 5G Universal Routing Platforms](#)

1

CHAPTER

Overview

[MX10003 System Overview | 2](#)

[MX10003 Chassis | 9](#)

[MX10003 Cooling System | 16](#)

[MX10003 AC Power System | 20](#)

[MX10003 DC Power System | 27](#)

[MX10003 Routing and Control Board | 32](#)

[MX10003 Interface Modules | 38](#)

MX10003 System Overview

IN THIS SECTION

- [Benefits of the MX10003 Router | 2](#)
- [MX10003 Router Hardware Overview | 3](#)
- [MX10003 Hardware Components and CLI Terminology | 4](#)
- [MX10003 Component Redundancy | 7](#)
- [MX10003 Field-Replaceable Units | 8](#)

The Juniper Networks MX10003 Universal Routing Platform is an Ethernet-optimized edge router with 2.4Tb capacity that provide both switching and carrier-class Ethernet routing. The MX10003 router runs Junos operating system (Junos OS), enabling a wide range of business and residential applications and services, including high-speed transport and virtual private network (VPN) services, next-generation broadband multiplay services, and high-volume Internet data center internetworking. Each router provides full duplex, *high-density Ethernet* interfaces and high- capacity switching throughput and uses the Junos Trio chipset for increased scalability of Layer 2/Layer 3 packet forwarding, buffering, and queuing.

Benefits of the MX10003 Router

- **Space-optimized, power-efficient cloud-era routing platform**—The MX10003 caters to the edge and Metro Ethernet needs of service providers, mobile operators, multiple-service operators in space- and power-constrained environments. Delivering 2.4 Tbps of throughput in just three rack units (3 U), the MX10003 delivers industry-leading port density and performance while consuming just 0.9 watts per gigabit of throughput.
- **Integrated high-precision timing**—The MX10003 router eliminates the need for external clocks by supporting highly scalable and reliable hardware-based timing including Synchronous Ethernet for frequency, and Precision Time Protocol (PTP) for frequency and phase synchronization. The router uses a hybrid mode, combining Synchronous Ethernet and PTP, to achieve a high level of frequency (10 ppb) and phase (<1.5 uS) accuracy.

- **Simplified management through Junos Fusion**—You can use the MX10003 as aggregation devices in a Junos Fusion Provider Edge deployment, where EX Series and QFX Series switches function as satellite devices.

MX10003 Router Hardware Overview

The MX10003 router contains modular Routing Engines and multiple Packet Forwarding Engines. The Packet Forwarding Engine has two “pseudo” Flexible PIC Concentrators (FPC 0 and FPC1). The single Packet Forwarding Engine takes care of both ingress and egress packet forwarding.

The MX10003 is a compact router, three rack units (3U) tall. Several routers can be stacked in a single floor-to-ceiling rack for increased port density per unit of floor space.

The router provides two dedicated line card slots for Modular Port Concentrators (MPCs). MPCs install into the line-card slots. The router supports two redundant Routing and Control Board (RCB). The RCB houses the Routing Engine and Control Board. The router is powered by six dedicated AC/DC power supply modules. Cooling is handled by four fan modules.

See [Table 1 on page 3](#) for components supported on the router.

Table 1: MX10003 Router Components

Component	Description
MPC	2
Routing and Control Board (RCB)	2
Power supply module	6
Fan module	4

Starting in Junos OS Release 18.3R1, you can use the Mellanox 10-Gbps pluggable adapter (QSFP+ to SFP+ adapter or QSA; model number: MAM1Q00A-QSA) to convert four lane-based ports to a single lane-based SFP+ port. The QSA adapter has the QSFP+ form factor with a receptacle for the SFP+ module. Use the QSA adapter to convert a 40-Gbps port to a 10-Gbps or a 1-Gbps port. You can configure the 4x10 Gbps ports on the fixed pic (6XQSFPP) and the QSFP28 ports on the non-MACSEC MIC (JNP-MIC1) in the 1-Gbps mode, when the SFP is plugged in through the QSA adapter.

NOTE:

- The interface name prefix must be xe.
- Rate selectability at PIC level and port level does not support 1-Gbps speed.
- For the link to come up, you must configure the no-auto-neg statement on the egress interface.

NOTE: For a complete list of supported optics on MX10003, see [MX10003 Transceivers](#).

SEE ALSO

[MX10003 Cooling System Description | 16](#)

[MX10003 AC Power System Description | 21](#)

[MX10003 Router Physical SpecificationsTo be reviewed for Vertex. | 54](#)

MX10003 Hardware Components and CLI Terminology

The MX10003 router support the components in [Table 2 on page 4](#), listed in alphabetic order.

Table 2: MX10003 Router Hardware Components and CLI Terminology

Component	Hardware Model Number	CLI Name	Description
Chassis	MX10003-Base	JNP10003 [MX10003]	"MX10003 Chassis Description" on page 10
Cooling system, including fan modules and air filters			"MX10003 Cooling System Description" on page 16
Air filter kit	JNP-AIRFLTR-3RU	N/A	
Fan module	JNP-FAN-3RU	Fan Tray	

Table 2: MX10003 Router Hardware Components and CLI Terminology (Continued)

Component	Hardware Model Number	CLI Name	Description
Power system components			"MX10003 AC Power System Description" on page 21
Power supply module	<ul style="list-style-type: none"> JNP-PWR1600-AC JNP-PWR1100-DC 	<ul style="list-style-type: none"> JNP-PWR1600-AC JNP-PWR1100-DC 	
MIC	<ul style="list-style-type: none"> Without MACsec support: JNP-MIC1 With MACsec support: JNP-MIC1-MACSEC 	<ul style="list-style-type: none"> MIC1 MIC1-MACSEC 	<i>Multi-Rate Ethernet MIC</i>
MPC	MX10003-LC2103.	LC2103	"MX10003 MPC (Multi-Rate)" on page 39
MPC	MX10003-LC2103-V2.	LC2103	"MX10003 MPC (Multi-Rate)" on page 39
Routing and Control Board (RCB)	<ul style="list-style-type: none"> JNP10003-RE1 JNP10003-RE1-LT 	<ul style="list-style-type: none"> RE: RE-S-1600x8 CB: Control Board 	"MX10003 Routing and Control Board (RCB) Description" on page 32
Transceiver	See MX Series Interface Module Reference .	Xcvr	Hardware Compatibility Tool

[Table 3 on page 5](#) lists the spare parts and blank panels available for the router.

Table 3: MX10003 Spare Parts and Blank Panels

Model Number	Description
JNP10003-CHAS	MX10003 chassis, spare

Table 3: MX10003 Spare Parts and Blank Panels (Continued)

Model Number	Description
JNP-FAN-3RU	MX10003 fan module, spare
JNP10003-RE1	MX10003 RE, spare
JNP10003-RE1-R	JNP10003 RE, redundant
JNP10003-LC2103	MX10003 MPC, 6 quad small form-factor pluggable plus transceivers (QSFP+), 1 MIC slot
JNP-PWR1600-AC	MX10003 AC power supply module
JNP-PWR1600-AC-R	MX10003 AC power supply, 1600 W, redundant
JNP-PWR1100-DC	MX10003 DC power supply, 1100 W
JNP-PWR1100-DC-R	MX10003 DC power supply, 1100 W, redundant
JNP-FLTRDR-3RU	MX10003 air filter assembly
JNP-AIRFLTR-3RU	MX10003 air filter
JNP-RE-BLNK-3	MX10003 RE blank cover panel
JNP-PWR-BLNK-3	MX10003 power blank cover panel
JNP-LC-BLNK-3	MX10003 LC2103 blank cover panel
JNP-MIC-BLNK-3	MX10003 MIC1 blank cover panel

MX10003 Component Redundancy

A fully configured router is designed so that no single point of failure can cause the entire system to fail. Only a fully configured router provides complete redundancy. All other configurations provide partial redundancy. The following major hardware components are redundant:

- **Host subsystem**—The host subsystem consists of two Routing and Control Boards (RCBs). The RCB is an integrated board and a single FRU that provides Routing Engine and Control Board functionality. The router can have one or two host subsystems. If two host subsystems are installed, one functions as the primary and the other functions as the backup. If the primary host subsystem (or either of its components) fails, the backup can take over as the primary. The RCB installed in slot **0** functions as the default primary.
- **Power supplies**—The router supports six power supplies. [Table 4 on page 7](#) shows the power redundancy supported on the AC and DC powered router for minimum operation. Minimum power supplies required for non-redundant operation is 2 for AC (high), 3 for DC, and 4 for AC (low). With additional power supplies, it provides $N+1$ and $N+N$ redundancy for the system. Both AC and DC systems can withstand the failure of a single power supply without system interruption in $N+1$ redundancy mode. If one power supply fails in a fully redundant system, the other power supply can provide full power to the router indefinitely.

Table 4: Power Supply Redundancy

Power Supply	PSM Redundancy	Feed Redundancy
AC (250 V; high)	2+1	2+2
AC (110 V; low)	4+1	Not allowed
DC	3+1	3+3

- **Cooling system**—The cooling system has a total of four fan modules, which are controlled and monitored by the host subsystem. A fully configured router needs all the four fan modules to operate normal. The fan modules are at the rear and are used to cool the router. If a fan fails or the temperature rises above the temperature threshold, the speed of the remaining fans is automatically adjusted to keep the temperature within the acceptable range.



CAUTION: For a fully configured router, all the four fan modules must be operational, and in the event of any fan module failure the failed fan module must be replaced immediately.

SEE ALSO

[Locating the Serial Number on a MX10003 Router or Component | 159](#)

[Guidelines for Packing Hardware Components for Shipment | 164](#)

How to Return a Hardware Component to Juniper Networks, Inc.

MX10003 Field-Replaceable Units

Field-replaceable units (FRUs) are router components that can be replaced at the customer site (see [Table 5 on page 9](#)). Replacing most FRUs requires minimal router downtime. The router uses the following types of FRUs:

- Hot-removable and hot-insertable FRUs—You can remove and replace these components without powering off the router or disrupting the routing functions.
- Hot-pluggable FRUs—You can remove and replace these components without powering off the router, but the routing functions of the system are interrupted when the component is removed.

[Table 5 on page 9](#) lists the FRUs for the router.

Table 5: Field-Replaceable Units

Hot-Removable and Hot-Insertable FRUs	Hot-Pluggable FRUs
<ul style="list-style-type: none"> • Backup RCB (if redundant) • Primary RCB (if <i>nonstop active routing</i> is configured) • Modular Port Concentrators (MPCs) • Modular Interface Cards (MICs) <p style="margin-left: 20px;">NOTE: MIC installed in MPC slot 1.</p> <ul style="list-style-type: none"> • Power supply modules (if redundant) • Fan modules (if redundant) • Air filter unit 	<ul style="list-style-type: none"> • Routing and Control Boards (RCB) (nonredundant) • Primary RCB (if <i>nonstop active routing</i> is not configured)

SEE ALSO

[Replacing an MX10003 DC Power Supply | 121](#)

[Replacing an MX10003 AC Power Supply | 118](#)

[Replacing the MX10003 Air Filter Unit | 107](#)

[Replacing an MX10003 Fan Module | 114](#)

[Replacing an MX10003 MIC | 132](#)

[Replacing an MX10003 MPC | 138](#)

MX10003 Chassis

IN THIS SECTION

● [MX10003 Chassis Description | 10](#)

● [MX10003 Front and Rear Panel Components | 12](#)

- [MX10003 Cable Management Bracket Description | 13](#)
- [Alarm LEDs on the MX10003 Front Panel | 14](#)

MX10003 Chassis Description

The router chassis is a rigid sheet metal structure that houses all the other router components. [Figure 1 on page 10](#) shows the front of the fully configured chassis. The chassis measures 5.21 in. (13.23 cm) high, 17.6 in. (44.7 cm) wide, and 30 in. (76.2 cm) deep. The chassis installs in standard 800-mm or 900-mm deep open rack, 19-in. equipment racks, or telco open-frame racks. The total weight of a fully loaded router: up to 157.4 lb (71.4 kg) for an AC-powered chassis, and up to 163.4 lb (74.1 kg) for a DC-powered chassis. For more information, see "[MX10003 Router Physical Specifications To be reviewed for Vertex.](#)" on page 54.

Figure 1: Front View of the MX10003 Router

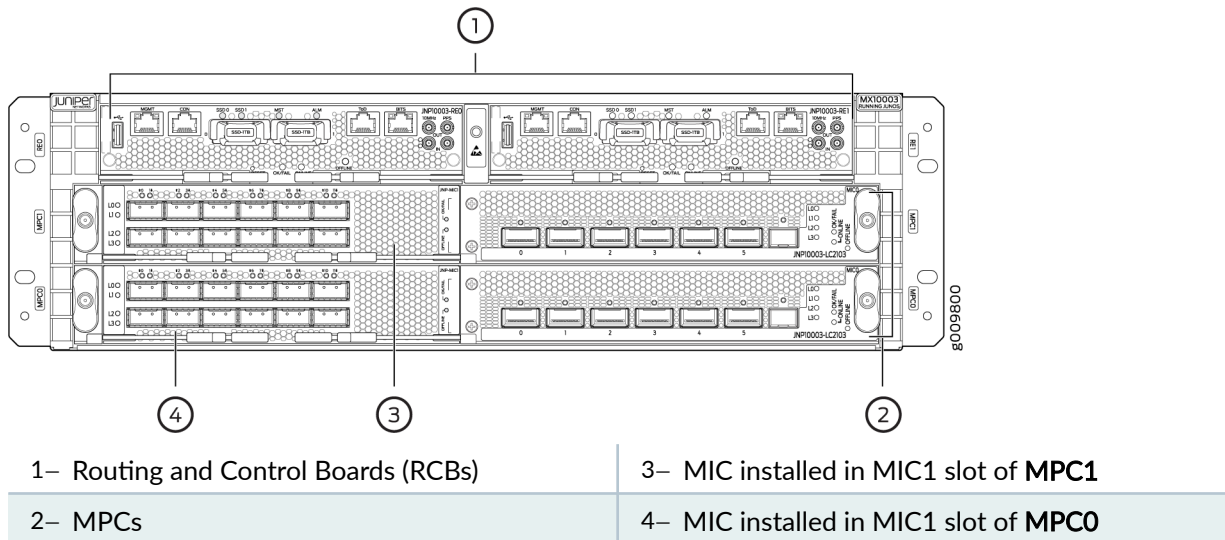

The router comes in two variants—AC-powered and DC-powered. [Figure 2 on page 11](#) and [Figure 3 on page 11](#) shows the rear of the fully configured chassis.

Figure 2: Rear View of the AC-Powered MX10003 Router

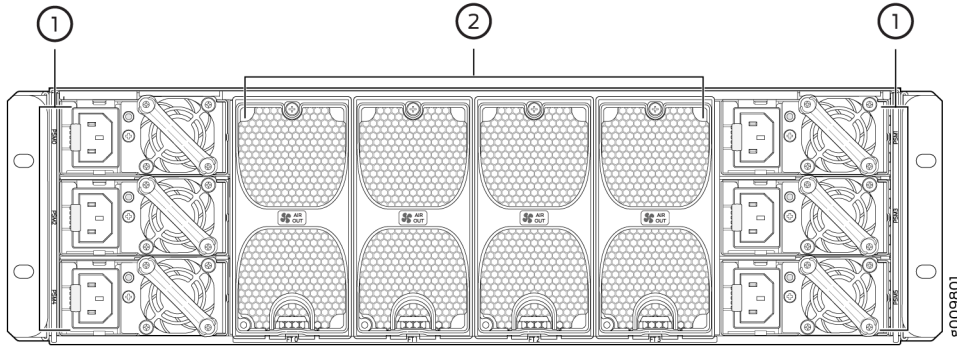

1- Power supply modules (AC)

2- Fan modules

Figure 3: Rear View of the DC-Powered MX10003 Router

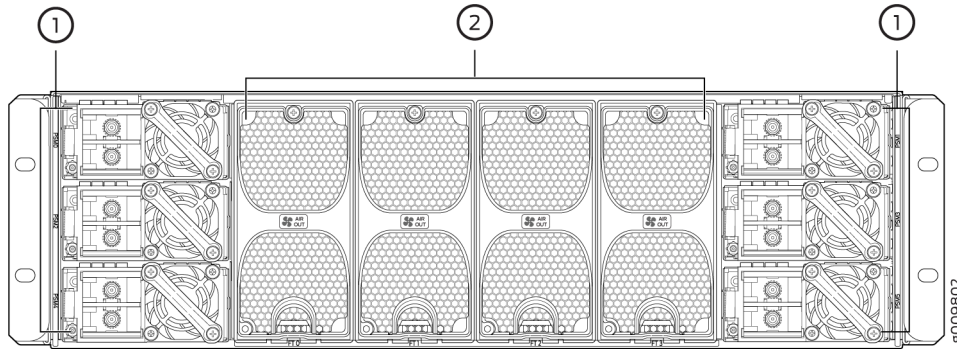

1- Power supply modules (DC)

2- Fan modules

Figure 4 on page 12 shows the electrostatic discharge (ESD) point on the router.



CAUTION: Before removing or installing components, attach an ESD strap to an ESD point, and place the other end of the strap around your bare wrist. Failure to use an ESD strap could result in damage to the hardware components.

Figure 4: ESD Point on the MX10003 Router

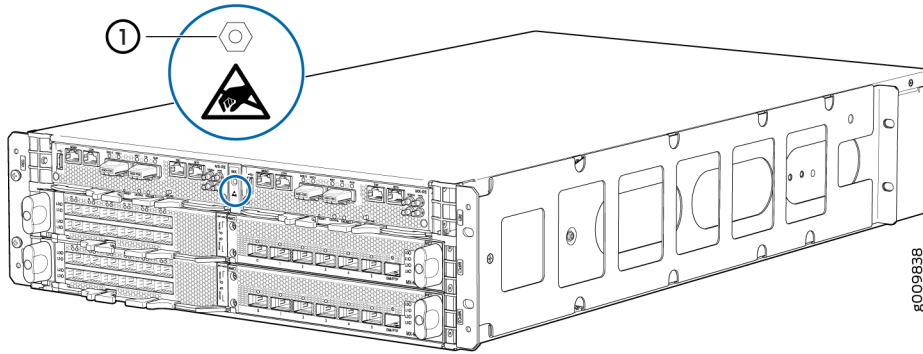

1– ESD point

MX10003 Front and Rear Panel Components

IN THIS SECTION

- [Front Panel Components | 12](#)
- [Rear Panel Components | 13](#)

The front panel on the front of the router enables you to view status and troubleshooting information at a glance. The front panel contains LEDs for the router components, online/offline and reset buttons, auxiliary and console ports, clocking ports, and ports for the 10-Gigabit Ethernet MIC.

Front Panel Components

[Table 6 on page 12](#) lists the components on the front panel of the MX10003 router.

Table 6: Front Panel Components in a Fully Configured MX10003 Router

Component	Slots	Number of FRUs
RCB	0 and 1	2

Table 6: Front Panel Components in a Fully Configured MX10003 Router (Continued)

Component	Slots	Number of FRUs
MPC	0 and 1	2
MIC (installed in MPC)	1 per MPC NOTE: MIC installs in slot 1 of the MPC.	1
Cable management brackets	-	2
Air filter unit	-	1

Rear Panel Components

[Table 7 on page 13](#) lists the components on the rear panel of the MX10003 router.

Table 7: Rear Panel Components in a Fully Configured MX10003 Router

Component	Slots	Number of FRUs
Power supply module	0 through 5	6
Fan module	0 through 3	4

MX10003 Cable Management Bracket Description

The cable management bracket (see [Figure 5 on page 14](#)) consists of dividers and installs on the front of the chassis. The cable management bracket enables you to route the cables outside the router and away from the RCBs, MICs, and MPCs.

Figure 5: Cable Management Bracket

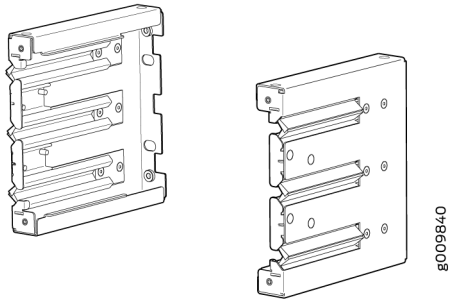

The air filter unit is installed on the cable management brackets. Before installing the air filter unit, ensure that the cable management brackets are already installed on the front of the router. [Figure 6 on page 14](#) shows the air filter unit along with the cable management brackets installed on the router.

Figure 6: Cable Management Brackets and Air Filter Unit Installed on the Router

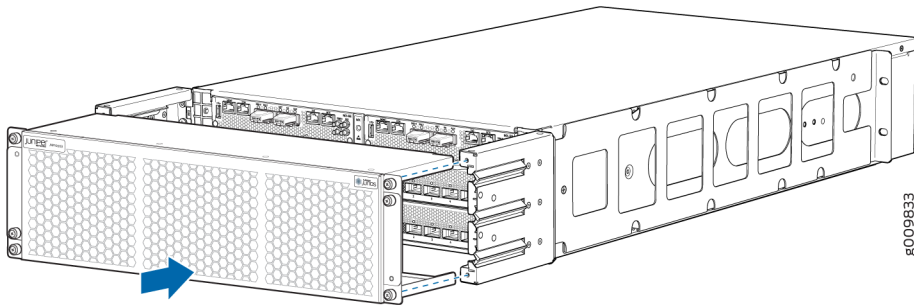

SEE ALSO

[Replacing the MX10003 Air Filter Unit | 107](#)

[Installing the MX10003 Router in a Rack | 78](#)

Alarm LEDs on the MX10003 Front Panel

One alarm LED located on the front panel of the RCB. A red light indicates a critical condition that can result in a system shutdown, and a yellow light indicates a less severe condition that requires monitoring or maintenance.

Table 8 on page 15 describes the alarm LED in more detail.

NOTE: Only the primary RCB drives the LED to show the status of the chassis.

Table 8: Alarm LEDs on the MX10003 Front Panel

Shape	Color	Status Description
○	Red	Major alarm—Indicates a critical condition that can cause the router to stop functioning. Possible causes include component removal, failure, or overheating.
	Yellow	Minor alarm—Indicates a serious but nonfatal error condition, such as a maintenance alert or a significant increase in component temperature.
	Red	Both major and minor alarms—Indicates that both major and minor alarm conditions are present.

Table 8: Alarm LEDs on the MX10003 Front Panel *(Continued)*

Shape	Color	State Description
	-	No alarms are present.

SEE ALSO

[Routine Maintenance Procedures for MX10003 Routers](#) | 105

MX10003 Cooling System

IN THIS SECTION

- [MX10003 Cooling System Description](#) | 16
- [MX10003 Fan Module LED](#) | 19

MX10003 Cooling System Description

IN THIS SECTION

- [Fan Modules](#) | 17
- [Airflow](#) | 18
- [Air Filter Unit](#) | 19
- [Power Supply Cooling System](#) | 19

The cooling system components work together to keep all router components within the acceptable temperature range.

The cooling system consists of the following components:

Fan Modules

The chassis monitors the temperature of the router components. When the router is operating normally, the fans function at lower than full speed. If a fan fails or the ambient temperature rises above a threshold, the speed of the remaining fans is automatically adjusted to keep the temperature within the acceptable range. If the ambient maximum temperature specification is exceeded and the system cannot be adequately cooled, the Routing Engine shuts down the router by disabling output power from each power supply.

The router has four fan modules that install vertically at the rear of the router. Each fan module contains two counter-rotating fans. The fan modules are hot-insertable and hot-removable field-replaceable units (FRUs) (see [Figure 7 on page 17](#)).

Figure 7: Fan Module

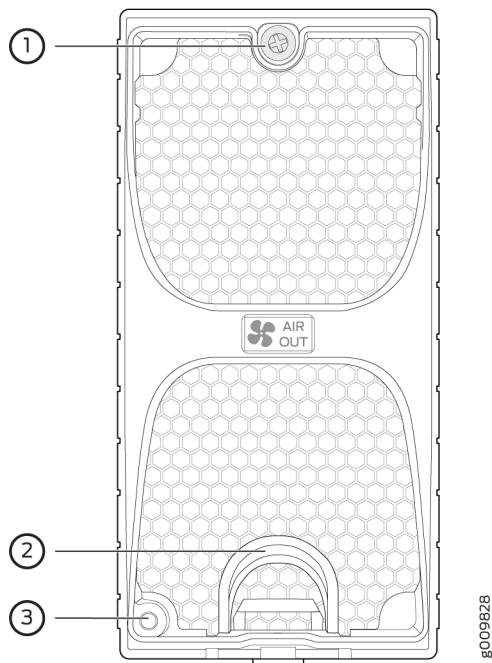

1– Captive screw

2– Latch

3– Status LED

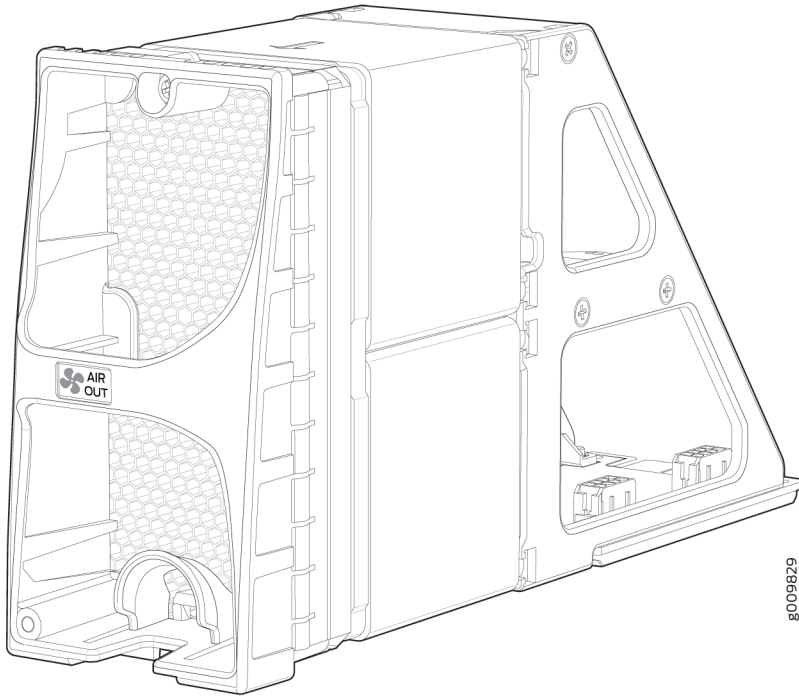

Airflow

The router has front-to-back (**AIR OUT**) cooling system (see [Figure 8 on page 18](#)). Air is pulled through the front the chassis toward the fan module, which exhausts the air out of the router.

Figure 8: Airflow Through the Router

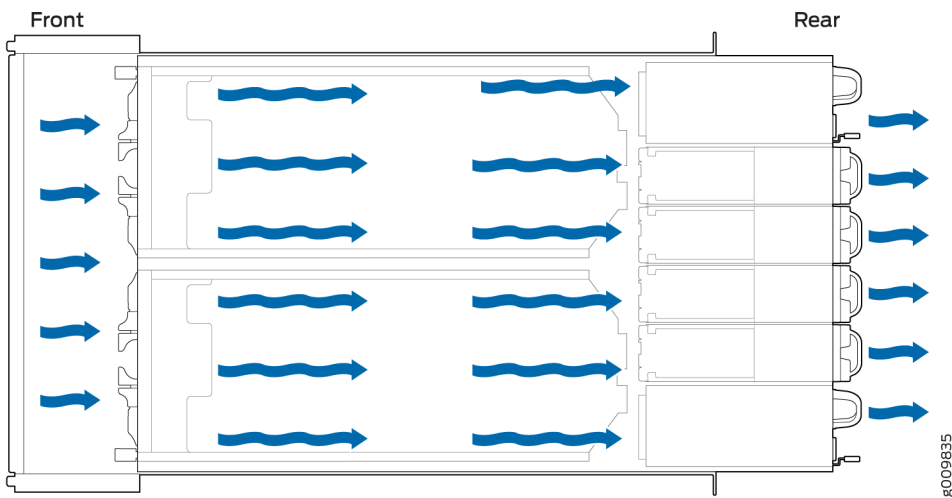

Air Filter Unit

The air filter unit consists of three parts—the outer filter cover, the air filter, and the inner cage that form the body, and the air filter (see [Figure 9 on page 19](#)). The air filter sits right inside the outer filter cover and the inner cage. The air filter unit is installed into the cable management brackets, and are held tightly by captive screws.

Figure 9: Air Filter Unit

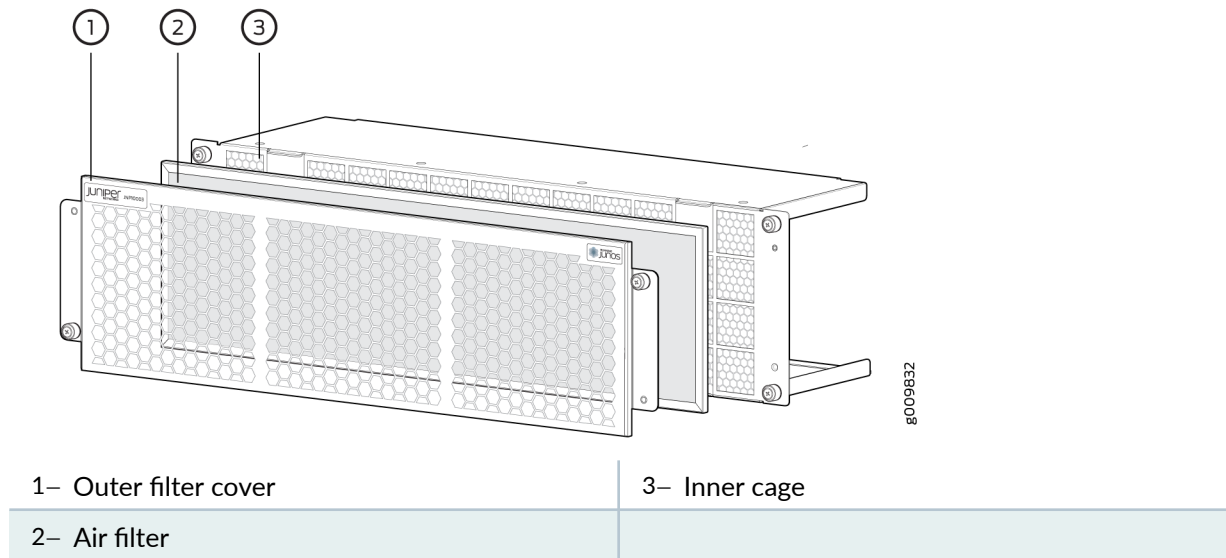

Power Supply Cooling System

The power supplies are self-cooling and are located in the rear of the router (to the left and the right of the rear of the chassis). The exhaust for the power supplies are also located on the rear of the chassis.

SEE ALSO

[Replacing the MX10003 Air Filter Unit | 107](#)

[Replacing the MX10003 Air Filter | 109](#)

MX10003 Fan Module LED

Each fan module contains one bicolor LED. "[MX10003 Cooling System Description](#)" on [page 16](#) shows the fan module LED.

Table 9 on page 20 describes the behavior of the fan module LEDs.

Table 9: Fan Module LEDs

Label	Color	State	Description
STATUS	Green	Blinking	Fan module hardware initialization complete and software initialization pending.
		On steadily	Software initialization complete and the fan is functioning normally.
	Red	On steadily	Faulty and not functioning normally

SEE ALSO

| [Replacing an MX10003 Fan Module | 114](#)

MX10003 AC Power System

IN THIS SECTION

- [MX10003 AC Power System Description | 21](#)
- [MX10003 AC Power Supply Module LEDs | 22](#)
- [MX10003 Router AC Power Specifications | 23](#)
- [AC Power Circuit Breaker Requirements for the MX10003 Router | 24](#)
- [AC Power Cord Specifications for MX10003 Routers | 24](#)

MX10003 AC Power System Description

The MX10003 uses either AC or DC power supply modules (see [Figure 10 on page 22](#)). The router contain six power supplies located at the rear of the chassis in slots **PSM0** through **PSM5**. The AC or DC power supplies directly plug into the midplane and are placed symmetrically on both sides of the chassis for better thermal management. Each power supply has a handle, an ejection lever, and a status LED. The power supplies connect to the baseboard, which distributes the different output voltages produced by the power supplies to the router components, depending on their voltage requirements. A minimum of 3 power supplies are required for non-redundant operation. If one power supply in a redundant configuration fails or is removed, the remaining power supplies assume the entire electrical load without interruption. See "[MX10003 Component Redundancy](#)" on [page 7](#) for more information on power redundancy supported on the AC and DC powered router. Each power supply is cooled by its own internal cooling system. The chassis is designed to support $N+N$ mode with feed redundancy, and $N+1$ mode without feed redundancy.

Redundant power supplies are hot-removable and hot-insertable.



CAUTION: Do not mix AC and DC power supplies in the same chassis.

NOTE: Routers configured with only one power supply are shipped with a blank panel installed over the power supply slot that is not populated.

Each AC power supply weighs approximately 3.4 lb (1.54 kg) and consists of a handle, an ejector lever, an AC appliance inlet, a fan, and an LED to monitor the status of the power supply. [Figure 10 on page 22](#) shows the power supply.

Each inlet requires a dedicated AC power feed and a dedicated customer-site circuit breaker. We recommend that you use a minimum 15-A (110 VAC) customer-site circuit breaker, or as required by local code.



WARNING: The router is a pluggable type A equipment installed in a restricted-access location. It has a separate protective earthing terminal (sized for M4 hex screws) provided on the chassis in addition to the grounding pin of the power supply cord. This separate protective earthing terminal must be permanently connected to earth.

Figure 10: AC Power Supply

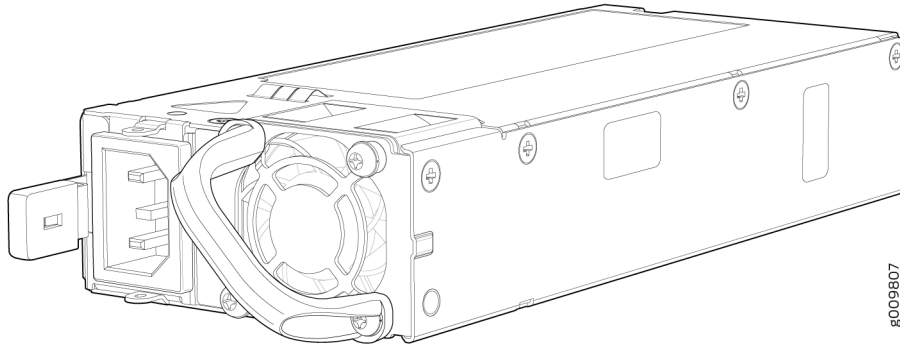

MX10003 AC Power Supply Module LEDs

Figure 11 on page 22 shows the AC power supplies components along with the status LED.

Figure 11: AC Power Supplies Components

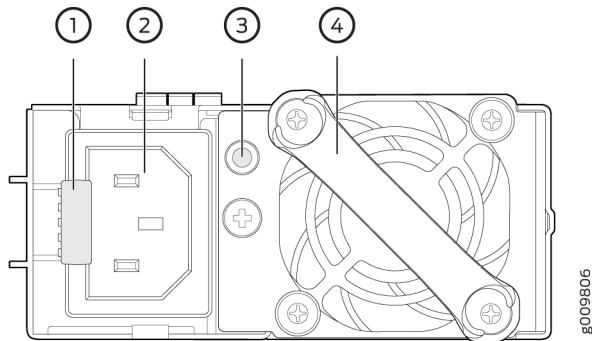

1– Ejector lever

2– AC inlet plug

3– Status LED

4– Handle

SEE ALSO

[Routine Maintenance Procedures for MX10003 Routers](#) | 105

MX10003 Router AC Power Specifications

Table 10 on page 23 lists the AC power system electrical specifications.

Table 10: AC Power System Electrical Specifications

Item	Specification
AC input voltage	Operating range: AC low: 90 through 140 VAC AC high: 180 through 264 VAC
AC input line frequency	50 through 60 Hz (nominal)
AC system current rating	25 A
AC system input power	2500 W

Table 11 on page 23 lists the AC power supply electrical specifications.

Table 11: AC Power Supply Electrical Specifications

Item	Specification
Maximum output power	AC high: 1600 W AC low: 800 W
AC input voltage	Operating range: 90 through 140 VAC: 800 W 180 through 264 VAC: 1600 W
AC input line frequency	50 through 60 Hz (nominal)
AC input current rating	10 A @ 100 VAC through 240 VAC

SEE ALSO

[Routine Maintenance Procedures for MX10003 Routers | 105](#)

[Replacing an MX10003 AC Power Supply | 118](#)

[General Safety Guidelines and Warnings | 169](#)

[General Electrical Safety Guidelines and Warnings | 192](#)

[Prevention of Electrostatic Discharge Damage | 173](#)

AC Power Circuit Breaker Requirements for the MX10003 Router

We recommend that you use a dedicated customer-site circuit breaker rated for 15 A (110 VAC) minimum or 10 A (220 VAC) minimum for each AC power feed, or as required by local code. Doing so enables you to operate the router in any configuration without upgrading the power infrastructure.

SEE ALSO

[Routine Maintenance Procedures for MX10003 Routers | 105](#)

[Replacing an MX10003 AC Power Supply | 118](#)

[Calculating Power Requirements for MX10003 Router | 58](#)

[General Safety Guidelines and Warnings | 169](#)

[General Electrical Safety Guidelines and Warnings | 192](#)

[Prevention of Electrostatic Discharge Damage | 173](#)

AC Power Cord Specifications for MX10003 Routers

A detachable AC power cord is supplied with the AC power supplies. The coupler is type C13 as described by International Electrotechnical Commission (IEC) standard 60320. The plug end of the power cord fits into the power source outlet that is standard for your geographical location.



CAUTION: The AC power cord provided with each power supply is intended for use with that power supply only and not for any other use.

NOTE: In North America, AC power cords must not exceed 4.5 meters in length, to comply with National Electrical Code (NEC) Sections 400-8 (NFPA 75, 5-2.2) and 210-52 and Canadian Electrical Code (CEC) Section 4-010(3). The cords supplied with the switch are in compliance.

Table 12 on page 25 gives the AC power cord specifications for the countries and regions listed in the table.

Table 12: AC Power Cord Specifications

Country/Region	Electrical Specifications	Plug Standards	Juniper Model Number
Argentina	250 VAC, 10 A, 50 Hz	IRAM 2073 Type RA/3	CBL-EX-PWR-C13-AR
Australia	250 VAC, 10 A, 50 Hz	AS/NZZS 3112 Type SAA/3	CBL-EX-PWR-C13-AU
Brazil	250 VAC, 10 A, 50 Hz	NBR 14136 Type BR/3	CBL-EX-PWR-C13-BR
China	250 VAC, 10 A, 50 Hz	GB 1002-1996 Type PRC/3	CBL-EX-PWR-C13-CH
Europe (except Italy, Switzerland, and United Kingdom)	250 VAC, 10 A, 50 Hz	CEE (7) VII Type VIIG	CBL-EX-PWR-C13-EU
India	250 VAC, 10 A, 50 Hz	IS 1293 Type IND/3	CBL-EX-PWR-C13-IN
Israel	250 VAC, 10 A, 50 Hz	SI 32/1971 Type IL/3G	CBL-EX-PWR-C13-IL
Italy	250 VAC, 10 A, 50 Hz	CEI 23-16 Type I/3G	CBL-EX-PWR-C13-IT
Japan	125 VAC, 12 A, 50 Hz or 60 Hz	JIS 8303	CBL-EX-PWR-C13-JP
Korea	250 VAC, 10 A, 50 Hz or 60 Hz	CEE (7) VII Type VIIGK	CBL-EX-PWR-C13-KR

Table 12: AC Power Cord Specifications (Continued)

Country/Region	Electrical Specifications	Plug Standards	Juniper Model Number
North America	125 VAC, 13 A, 60 Hz	NEMA 5-15 Type N5-15	CBL-EX-PWR-C13-US
South Africa	250 VAC, 10 A, 50 Hz	SABS 164/1:1992 Type ZA/13	CBL-EX-PWR-C13-SA
Switzerland	250 VAC, 10 A, 50 Hz	SEV 6534-2 Type 12G	CBL-EX-PWR-C13-SZ
Taiwan	125 VAC, 11 A and 15 A, 50 Hz	NEMA 5-15P Type N5-15P	CBL-EX-PWR-C13-TW
United Kingdom	250 VAC, 10 A, 50 Hz	BS 1363/A Type BS89/13	CBL-EX-PWR-C13-UK

Figure 12 on page 26 illustrates the plug on the power cord for some of the countries or regions listed in Table 12 on page 25.

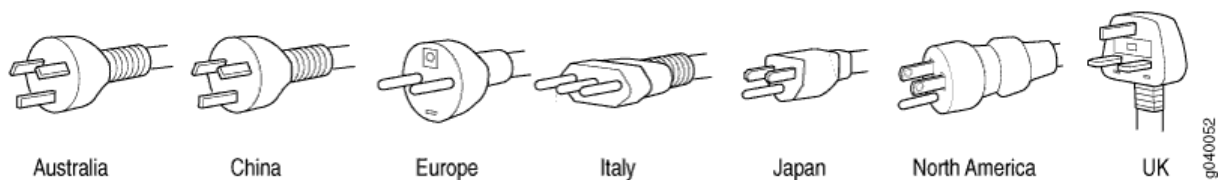
Figure 12: AC Plug Types**SEE ALSO**

[General Safety Guidelines and Warnings | 169](#)

[General Electrical Safety Guidelines and Warnings | 192](#)

[Prevention of Electrostatic Discharge Damage | 173](#)

MX10003 DC Power System

IN THIS SECTION

- [MX10003 DC Power System Description | 27](#)
- [MX10003 DC Power Supply Module LEDs | 28](#)
- [MX10003 Router DC Power Specifications | 29](#)
- [DC Power Circuit Breaker Requirements for the MX10003 Router | 29](#)
- [DC Power Source Cabling for MX10003 Router | 30](#)
- [DC Power Cable Specifications for MX10003 Router | 31](#)

MX10003 DC Power System Description

The MX10003 uses either AC or DC power supply modules (see [Figure 13 on page 28](#)). The router contain six power supplies located at the rear of the chassis in slots **PSM0** through **PSM5**. The AC or DC power supplies directly plug into the midplane and are placed symmetrically on both sides of the chassis for better thermal management. Each power supply has a handle, an ejection lever, and a status LED. The power supplies connect to the baseboard, which distributes the different output voltages produced by the power supplies to the router components, depending on their voltage requirements. A minimum of 3 power supplies are required for non-redundant operation. If one power supply in a redundant configuration fails or is removed, the remaining power supplies assume the entire electrical load without interruption. See "[MX10003 Component Redundancy](#)" on [page 7](#) for more information on power redundancy supported on the AC and DC powered router. Each power supply is cooled by its own internal cooling system. The chassis is designed to support $N+N$ mode with feed redundancy, and $N+1$ mode without feed redundancy.

Redundant power supplies are hot-removable and hot-insertable.



CAUTION: Do not mix AC and DC power supplies in the same chassis.

NOTE: Routers configured with only one power supply are shipped with a blank panel installed over the power supply slot that is not populated.

Each DC power supply weighs approximately 4.4 lb (1.99 kg) and consists of a handle, an ejector lever, a status LED, and a terminal block that provides a single DC input (-48 VDC and return) that requires a dedicated customer-site circuit breaker. We recommend that you use a dedicated customer-site circuit breaker rated for 40 A (-48 VDC) minimum, or as required by local code.

Figure 13 on page 28 shows the power supply.

Figure 13: DC Power Supply

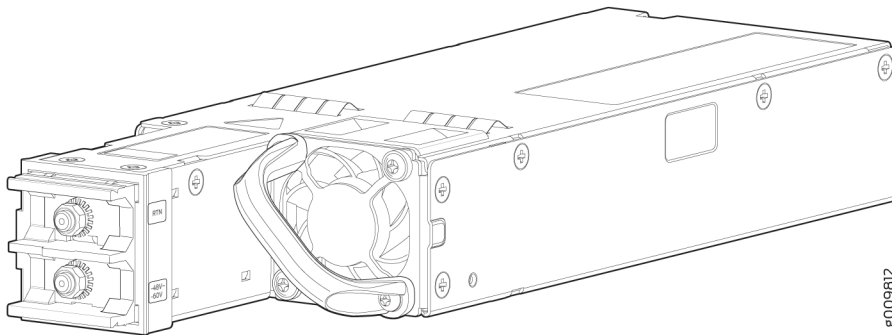

MX10003 DC Power Supply Module LEDs

Figure 14 on page 28 shows the DC power supplies components along with the status LED.

Figure 14: DC Power Supplies Components

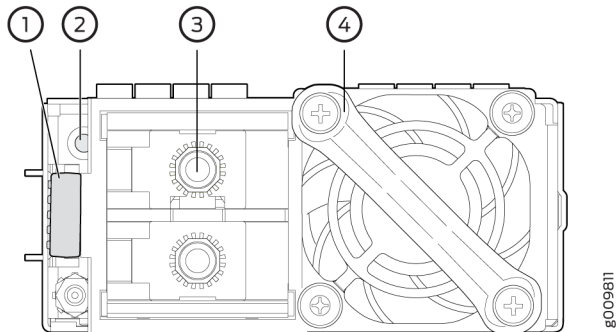

1- Ejector lever

2- Status LED

3- DC inlet cable lug point

4- Handle

MX10003 Router DC Power Specifications

Table 13 on page 29 lists the DC power supply electrical specifications.

Table 13: DC Power Supply Electrical Specifications

Item	Specification
Maximum output power	1100 W
DC output voltage	Nominal: 12VDC
DC input voltage	Minimum: -40 VDC Nominal: -48 VDC, -60 VDC Operating range: -40 through -72 VDC

SEE ALSO

[Routine Maintenance Procedures for MX10003 Routers | 105](#)

[Replacing an MX10003 DC Power Supply | 121](#)

[MX10003 Power Planning | 58](#)

[General Safety Guidelines and Warnings | 169](#)

[General Electrical Safety Guidelines and Warnings | 192](#)

[Prevention of Electrostatic Discharge Damage | 173](#)

DC Power Circuit Breaker Requirements for the MX10003 Router

Each DC power supply has a single DC input (-48 VDC and return) that requires a dedicated circuit breaker. We recommend that you use a dedicated customer-site circuit breaker rated for 40 A (-48 VDC) minimum, or as required by local code. Doing so enables you to operate the router in any configuration without upgrading the power infrastructure.

If you plan to operate a DC-powered router at less than the maximum configuration and do not provision a 40 A (-48 VDC) circuit breaker, we recommend that you provision a dedicated customer-site

circuit breaker for each DC power supply rated for at least 125 percent of the continuous current that the system draws at -48 VDC.

SEE ALSO

[Routine Maintenance Procedures for MX10003 Routers | 105](#)

[Replacing an MX10003 DC Power Supply | 121](#)

[MX10003 Power Planning | 58](#)

[General Safety Guidelines and Warnings | 169](#)

[General Electrical Safety Guidelines and Warnings | 192](#)

[Prevention of Electrostatic Discharge Damage | 173](#)

DC Power Source Cabling for MX10003 Router

The DC power supply in **PS0** must be powered by a dedicated power feed derived from feed **A**, and the DC power supply in **PS1** must be powered by a dedicated power feed derived from feed **B**. This configuration provides the commonly deployed **A/B** feed redundancy for the system.



CAUTION: You must ensure that power connections maintain the proper polarity. The power source cables might be labeled (+) and (-) to indicate their polarity. There is no standard color coding for DC power cables. The color coding used by the external DC power source at your site determines the color coding for the leads on the power cables that attach to the terminal studs on each power supply.



WARNING: For field-wiring connections, use copper conductors only.



CAUTION: Power cords and cables must not block access to device components or drape where people could trip on them.

SEE ALSO

[Routine Maintenance Procedures for MX10003 Routers | 105](#)

[Replacing an MX10003 DC Power Supply | 121](#)

[MX10003 Power Planning | 58](#)

[General Safety Guidelines and Warnings | 169](#)

[General Electrical Safety Guidelines and Warnings | 192](#)

[Prevention of Electrostatic Discharge Damage | 173](#)

DC Power Cable Specifications for MX10003 Router

IN THIS SECTION

- [DC Power Cable Lug Specifications | 31](#)
- [DC Power Cable Specifications | 32](#)

DC Power Cable Lug Specifications

The accessory box shipped with the router includes the cable lugs that attach to the terminal of each power supply.

Figure 15: DC Power Cable Lug

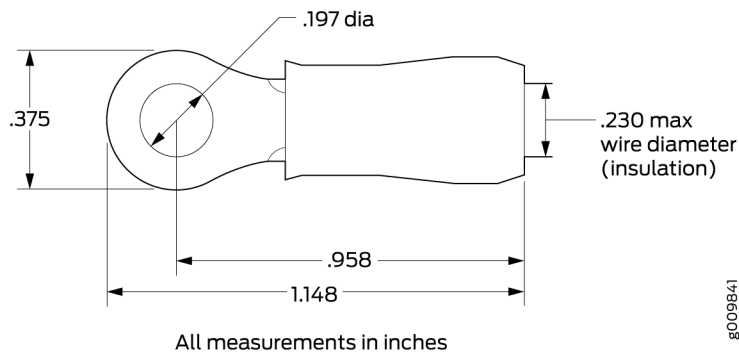

CAUTION: Before you install the router, a licensed electrician must attach a cable lug to the grounding and power cables that you supply. A cable with an incorrectly attached lug can damage the router.

DC Power Cable Specifications

You must supply four DC power cables that meet the following specifications: 10-AWG (1.3 mm²), minimum 60° C wire, or as required by the local code.

SEE ALSO

[Routine Maintenance Procedures for MX10003 Routers | 105](#)

[Replacing an MX10003 DC Power Supply | 121](#)

[MX10003 Power Planning | 58](#)

[General Safety Guidelines and Warnings | 169](#)

[General Electrical Safety Guidelines and Warnings | 192](#)

[Prevention of Electrostatic Discharge Damage | 173](#)

MX10003 Routing and Control Board

IN THIS SECTION

- [MX10003 Routing and Control Board \(RCB\) Description | 32](#)
- [MX10003 RCB LEDs | 37](#)

MX10003 Routing and Control Board (RCB) Description

IN THIS SECTION

- [Routing and Control Board Functions | 33](#)
- [Routing and Control Board Components | 33](#)
- [RCB Front Panel | 34](#)
- [RCB Interface Ports | 35](#)

The host subsystem provides routing protocol processes, as well as software processes that control the router's interface, the chassis components, system management, and user access to the router. These routing processes run on top of a kernel that interacts with the Packet Forwarding Engine. The MX10003 host subsystem consists of two Routing and Control Boards, or RCBs. The RCB is an integrated board and a single FRU that provides Routing Engine (RE) and Control Board (CB) functionality. The RE performs all route-processing functions, whereas the CB performs chassis control and management plane functionality. The RCB provides control plane functions. You can install one or two RCBs on the router. Each RCB functions as a unit.

NOTE: Install two RCBs for redundant protection. If you install only one RCB, you can install it in slot **0** or slot **1**. By default, slot **0** functions as the primary.



CAUTION: If one of the RCBs fails, do not remove the failed RCB until you have a replacement or blank panel to install.

The MX10003 router supports the following RCBs:

- JNP10003-RE1
- JNP10003-RE1-LT

This topic covers:

Routing and Control Board Functions

The Routing and Control Board integrates the Routing Engine and Control Board functions into a single management unit. Each RCB provides all the functions needed to manage the operation of the modular chassis:

- System control functions such as environmental monitoring
- Routing Layer 2 and Layer 3 protocols
- Communication to all components such as line cards, power, and cooling
- Transparent clocking
- Alarm and logging functions

Routing and Control Board Components

Each RCB consists of the following internal components:

- High-performance 1.6-GHz Intel 8 Core X86 CPU
- 64-GB DDR4 RAM
- 100-GB SATA SSD

RCB Front Panel

Figure 16 on page 34 shows the front panel of the MX10003 RCB (model number: JNP10003-RE1).

Figure 16: JNP10003-RE1 RCB Ports

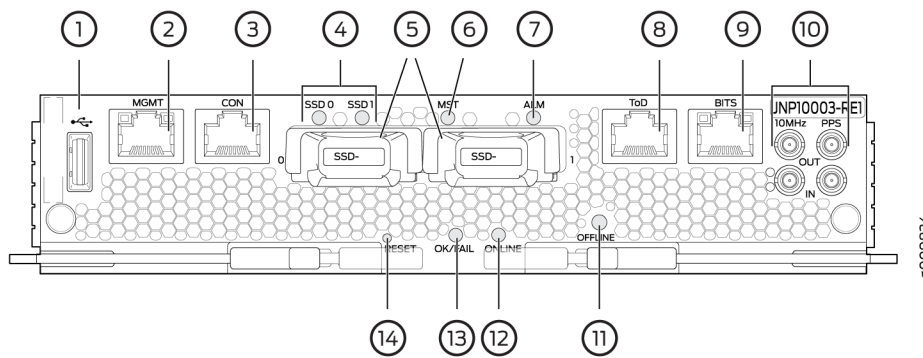

1– USB port	8– Time of day (ToD) port with LEDs (This port is reserved for future use)
2– Management (MGMT) port	9– BITS port with LEDs
3– Console (CON) port	10– Clocking ports
4– SSD LEDs	11– OFFLINE button
5– SSD slots (0 and 1)	12– ONLINE LED
6– Primary (MST) LED	13– OK/FAIL LED
7– Alarm (ALM) LED	14– RESET button

Figure 17 on page 35 shows the front panel of the MX10003 RCB with limited encryption support (model number: JNP10003-RE1-LT).

Figure 17: JNP10003-RE1-LT RCB Ports

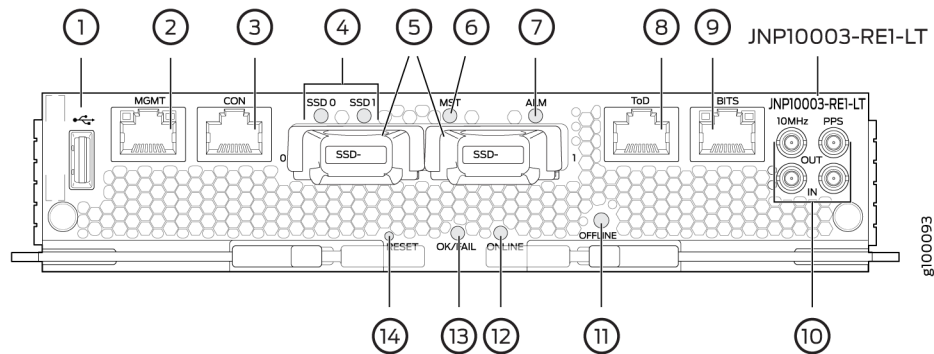

1– USB port	8– Time of day (ToD) port with LEDs (This port is reserved for future use)
2– Management (MGMT) port	9– BITS port with LEDs
3– Console (CON) port	10– Clocking ports
4– SSD LEDs	11– OFFLINE button
5– SSD slots (0 and 1)	12– ONLINE LED
6– Primary (MST) LED	13– OK/FAIL LED
7– Alarm (ALM) LED	14– RESET button

The MX10003 router with JNP10003-RE1-LT RCB supports only Junos Limited image. The Junos Limited image does not have data-plane encryption and is intended only for countries in the Eurasian Customs Union because these countries have import restrictions on software containing data-plane encryption. Unlike the Junos Worldwide image, the Junos Limited image supports control plane encryption through Secure Shell (SSH) and Secure Sockets Layer (SSL), thus allowing secure management of the system. The Limited Restriction RCB boots only the encryption free Junos software and fails to boot if the fully encrypted Junos software is used for booting. The Junos upgrade and VMHost upgrade using non-limited version of Junos software fails on the JNP10003-RE1-LT RCB.

The command `show chassis hardware [models | clei-models | extensive]` displays the model number and helps identifying the different SKUs. An alarm, Mixed Master and Backup RE types is displayed when dissimilar Routing Engines are present on the chassis (see *Chassis Alarms*).

RCB Interface Ports

The ports located on the RCB, connect the RCB to one or more external devices on which system administrators can issue Junos OS CLI commands to manage the router. In addition, ports to connect external clock interfaces for BITS and GPS function are also available on the RCB.

The RCB interface ports with the indicated labels function are as follows (see [Figure 16 on page 34](#)):

- **CON**—Connects the RCB to a system console through a serial cable with an RJ-45 connector.
- **MGMT**—Connects the RCB through an Ethernet connection to a management LAN (or any other device that plugs into an Ethernet connection) for out-of-band management. The port uses an autosensing RJ-45 connector to support 10-Mbps, 100-Mbps, or 1000-Mbps connections. Two small LEDs (an activity LED and a link LED) on the port indicate the connection in use.

The link LED is:

- lit amber (steady) when the 1000-Mbps link is up.
- lit green (steady) when the 100-Mbps link is up.
- off when the 10-Mbps link is up.

The activity LED is:

- lit green (blinking) when traffic is passing through the port.
- lit green (steady) when traffic is not passing through the port.

Both activity and link LEDs are off when the link is down.

- **BITS**—Building-integrated timing supply (BITS) external clocking interface for connection to external clocking devices.
- **ToD**—Time-of-day (TOD) port on the front panel of the router allows you to connect external timing signal sources.

NOTE: This port is reserved for future use.

- **10MHZ** (one input and one output)—The 10-MHz timing connectors on the front panel of the router connect to external clock signal sources. The clocking ports provide the synchronized output clocks from any one of the reference clock inputs based on the clock's priority.
- **PPS** (one input and one output)—1-pulse-per-second (PPS) connectors on the front panel of the router connect to external clock signal sources. The clocking ports provide the synchronized output clocks from any one of the reference clock inputs based on the clock's priority.
- **USB**—Provides a removable media interface through which you can install Junos OS manually. Junos OS supports USB version 1.0 and later.

SEE ALSO

[RJ-45 Connector Pinouts for an MX Series CB-RE or RCB Management Port | 70](#)

MX10003 RCB LEDs

The Routing and Control Board (RCB) is an integrated board and a single FRU that provides Routing Engine and Control Board functionality.

The LEDs—labeled **ONLINE**, **MST**, **OK/FAIL**, **LINK**, **GPS**, **BITS**—are located directly on the faceplate of the RCB. [Table 14 on page 37](#) describes the functions of the Routing Engine interface of the RCB.

NOTE: The functioning of the MX10003 router is controlled by the RCB, and the LEDs present on the RCBs displays the status and functioning of the MX10003 chassis.

Table 14: MX10003 RCB LEDs

Label	Color	State	Description
ONLINE	Green	Blinking	RCB is starting Junos OS.
	Yellow	Blinking	RCB is starting Linux.
		On steadily	Both Junos OS and Linux are successfully loaded on the RCB.
		Off	RCB is offline.
MST	Blue	On steadily	RCB is the primary.
	-	Off	RCB is the backup.
OK/FAIL	Yellow	On steadily	RCB has failed.
	Green	On steadily	RCB is functioning normally.

Table 14: MX10003 RCB LEDs (*Continued*)

Label	Color	State	Description
SSD0	Green	Blinking	SSD0 is active.
SSD1	Green	Blinking	SSD1 is active.
BITS	Green	On steadily	Building-integrated timing supply (BITS) external clocking interface is active.
	Red	On steadily	BITS external clocking interface has failed.
	-	Off	BITS external clocking interface is offline.

SEE ALSO

[Replacing an MX10003 RCB | 127](#)

RELATED DOCUMENTATION

Routing Engine Specifications

Supported Routing Engines by Router

MX10003 Interface Modules

IN THIS SECTION

- [MX10003 MPC \(Multi-Rate\) | 39](#)
- [MX10003 MPC \(Multi-Rate\) | 42](#)
- [MX10003 Port and Interface Numbering | 44](#)

- MX10003 MPC (Multi-Rate) LEDs | 45
- Multi-Rate Ethernet MIC LEDs | 45

MX10003 MPC (Multi-Rate)

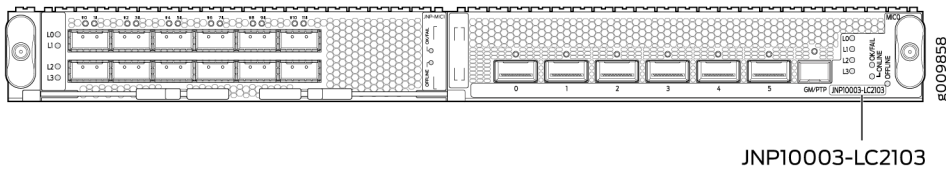

Software release

- Junos OS release 17.3R1 and later

Description

- Weight: 30 lb (13.61 kg) (net weight without blank panel and without any MIC in slot 1)
- Model number: MX10003-LC2103
- Power requirement:
 - 715 W at 55° C
 - 660 W at 25° C
- Name in the CLI: LC2103

Hardware features

- The MX10003 MPC is a 1.2-Terabit capable MPC with three Packet Forwarding Engine complexes (that is, EA ASICs). The EA ASIC operates in 400G mode.
- The Packet Forwarding Engine is based on the third generation of the Trio chipset architecture---namely, (Eagle) ASIC. The Packet Forwarding Engine offers 400 Gbps of WAN and fabric bandwidth each.
- MX10003 MPC has six built-in QSFP+ optics ports, and one MIC slot.
- Supports Multi-Rate Ethernet Modular Interface Card (MIC) (model numbers: JNP-MIC1 and JNP-MIC1-MACSEC), and the fixed-port PIC (6xQSFP). For information about which MICs are supported on this MPC, see *MIC/MPC Compatibility*.
- Supports maximum transmission units (MTUs) from 256 bytes through 16,000 bytes for transit traffic, and 256 bytes through 9,500 bytes for host bound packets.

Software features

- *Dynamic Power Management* for effective utilization of available power.
- *Inline Active Flow Monitoring* for higher scalability and performance.
- *Flexible Queuing Mode* to support 32,000 queues per line card, including queues on both ingress and egress interfaces. Supports up to 512,000 queues per slot or 768,000 queues per slot.
- *Hyper Mode* to speed up packet processing.
- Optical diagnostics and related alarms.

For more information about features supported on MX10003 MPC, see *Protocols and Applications Supported on the MX10003 MPC (Multi-Rate) on the MX10003 Router*.

Cables and connectors

TIP: You can use the [Hardware Compatibility Tool](#) to find information about the pluggable transceivers supported on your Juniper Networks device.

The list of supported transceivers for the MX Series is located at <https://pathfinder.juniper.net/hct/category/#catKey=100001&modelType;=All&pf;=MX+Series>.

Power requirements

(without MICs)

- At different temperatures:
 - 55° C: 715 W
 - 25° C: 660 W

LEDs

OK/FAIL LED, one bicolor:

- Steady green—MPC is functioning normally and the link is up.
- Off—MPC is plugged-in but not powered on.
- Red—MPC has failed.

For information on the lane LEDs (**L0**, **L1**, **L2**, and **L3**), see *MPC and MIC Lane LED Scheme Overview*.

[Table 15 on page 41](#) summarize the port speed capability of MX10003 MPCs.

Table 15: MX10003 MPC (Multi-Rate) Port Speed

MIC	Port Number	Port Speed Supported
PIC 0	0-5	40 Gigabit Ethernet 4X10-Gigabit Ethernet
PIC 1	0-11	100 Gigabit Ethernet 40 Gigabit Ethernet 4X10-Gigabit Ethernet

SEE ALSO

MPC and MIC Lane LED Scheme Overview

MX Series MPC Overview

MPCs Supported by MX Series Routers

MX10003 MPC (Multi-Rate)

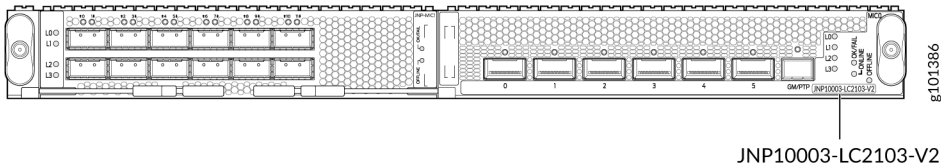

Software release

- Junos OS release 21.3R1 and later

Description

- Weight: 30 lb (13.61 kg) (net weight without blank panel and without any MIC in slot 1)
- Model number: MX10003-LC2103-V2
- Power requirement:
 - 725 W at 55° C
 - 665 W at 25° C
- Name in the CLI: LC2103

Hardware features

- The MX10003 MPC is a 1.2-Terabit capable MPC with three Packet Forwarding Engine complexes (that is, three EA ASICs). The EA ASIC operates in 400G mode.
- The Packet Forwarding Engine is based on the third generation of the Trio chipset architecture---namely, the Eagle ASIC. The Packet Forwarding Engine offers 400 Gbps of WAN and fabric bandwidth each.
- MX10003 MPC has six built-in QSFP+ optics ports, and one MIC slot.
- Supports Multi-Rate Ethernet Modular Interface Card (MIC) (model numbers: JNP-MIC1 and JNP-MIC1-MACSEC), and the fixed-port PIC (6xQSFP). For information about which MICs are supported on this MPC, see *MIC/MPC Compatibility*.
- Supports maximum transmission units (MTUs) from 256 bytes through 16,000 bytes for transit traffic, and 256 bytes through 9,500 bytes for host bound packets.

- Software features
- *Dynamic Power Management* for effective utilization of available power.
 - *Inline Active Flow Monitoring* for higher scalability and performance.
 - *Flexible Queuing Mode* to support 32,000 queues per line card, including queues on both ingress and egress interfaces. Supports up to 512,000 queues per slot or 768,000 queues per slot.
 - *Hyper Mode* to speed up packet processing.
 - Optical diagnostics and related alarms.

For more information about features supported on MX10003 MPC, see *Protocols and Applications Supported on the MX10003 MPC (Multi-Rate) on the MX10003 Router*.

Cables and connectors

TIP: You can use the [Hardware Compatibility Tool](#) to find information about the pluggable transceivers supported on your Juniper Networks device.

The list of supported transceivers for the MX Series is located at <https://pathfinder.juniper.net/hct/category/#catKey=100001&modelType;=All&pf;=MX+Series>.

-
- Power requirements
(without MICs)
- At different temperatures:
 - 55° C: 725 W
 - 25° C: 665 W

-
- LEDs
- OK/FAIL LED**, one bicolor:
- Steady green—MPC is functioning normally and the link is up.
 - Off—MPC is plugged-in but not powered on.
 - Red—MPC has failed.

For information on the lane LEDs (**L0**, **L1**, **L2**, and **L3**), see *MPC and MIC Lane LED Scheme Overview*.

[Table 16 on page 44](#) summarize the port speed capability of MX10003 MPCs.

Table 16: MX10003 MPC (Multi-Rate) Port Speed

MIC	Port Number	Port Speed Supported
PIC 0	0-5	40 Gigabit Ethernet 4X10-Gigabit Ethernet
PIC 1	0-11	100 Gigabit Ethernet 40 Gigabit Ethernet 4X10-Gigabit Ethernet

SEE ALSO

MPC and MIC Lane LED Scheme Overview

MX Series MPC Overview

MPCs Supported by MX Series Routers

MX10003 Port and Interface Numbering

In the physical part of the interface name, a hyphen (-) separates the media type from the *MPC* number (represented as an *FPC* in the CLI), and a slash (/) separates the logical PIC and port numbers:

type-fpc/pic/port

- *type*—Media type, which identifies the network device. For example:
 - xe—10-Gigabit Ethernet interface
 - et—100-Gigabit Ethernet interfaces (40 and 100-Gigabit Ethernet interface)

For a complete list of media types, see *Interface Naming Overview* in the [MX Series 5G Universal Routing Platform Interface Module Reference](#) guide.

- *fpc*—Slot in which the MPC is installed, and are represented in the CLI as either *FPC 0* or *FPC 1*.
- *pic*—Logical PIC on the *MIC*. The number of logical PICs varies depending on the type of *MIC*.

- *port*—Port number.

MX10003 MPC (Multi-Rate) LEDs

The MX10003 MPC (Multi-Rate) has LEDs located on the front panel.

[Table 17 on page 45](#) describes the link LEDs in more detail.

Table 17: MX10003 MPC (Multi-Rate) LEDs

LED Status	Color	State	Description
OK/FAIL	Green	On steadily	MPC is functioning normally and the link is up.
		Off	MPC is plugged-in but not powered on.
	Red	-	MPC has failed.
ONLINE	Green	-	MPC is online.

For information on the lane LEDs (**Lo**, **L1**, **L2**, and **L3**), see *MPC and MIC Lane LED Scheme Overview*.

SEE ALSO

MPC and MIC Lane LED Scheme Overview

MICs Supported by MX Series Routers

Multi-Rate Ethernet MIC LEDs

For the Multi-Rate MICs supported by MX series routers, see *Multi-Rate Ethernet MIC*.

The Multi-Rate Ethernet Modular Interface Card (MIC) has link LEDs located on the front panel.

[Table 18 on page 46](#) describes the link LEDs in more detail.

Table 18: Multi-Rate Ethernet MIC LEDs

Color	State	Description
Green	On steadily	Link is up.
	Off	No link.

Like port status LED, each individual lane LED support four states: OFF, AMBER, GREEN, RED. See *MPC and MIC Lane LED Scheme Overview* for more details.

SEE ALSO

MPC and MIC Lane LED Scheme Overview

MICs Supported by MX Series Routers

2

CHAPTER

Site Planning, Preparation, and Specifications

MX10003 Site Preparation Checklist | 48

MX10003 Site Guidelines and Requirements | 49

MX10003 Power Planning | 58

MX10003 Network Cable and Transceiver Planning | 63

MX10003 Management and Console Port Specifications and Pinouts | 68

MX10003 Site Preparation Checklist

The checklist in [Table 19 on page 48](#) summarizes the tasks you must perform when preparing a site for router installation.

Table 19: MX10003 Site Preparation Checklist

Item or Task	For More Information
Environment	
Verify that environmental factors such as temperature and humidity do not exceed router tolerances.	"MX10003 Router Environmental Specifications" on page 50
Power	
Locate sites for connection of system grounding.	"MX10003 Router Grounding Specifications" on page 51
Measure distance between external power sources and router installation site.	"MX10003 Router DC Power Specifications" on page 29 "MX10003 Router AC Power Specifications" on page 23
Calculate the power consumption and requirements.	"Calculating Power Requirements for MX10003 Router" on page 58
Rack	
Plan rack location, including required space clearances.	"MX10003 Router Clearance Requirements for Airflow and Hardware Maintenance" on page 54
Secure rack to floor and building structure.	"MX10003 Router Rack Requirements" on page 56
Cables	

Table 19: MX10003 Site Preparation Checklist (Continued)

Item or Task	For More Information
<p>Acquire cables and connectors:</p> <ul style="list-style-type: none"> • Determine the number of cables needed based on your planned configuration. • Review the maximum distance allowed for each cable. Choose the length of cable based on the distance between the hardware components being connected. 	<p>"Calculating Power Budget and Power Margin for Fiber-Optic Cables" on page 63</p>

RELATED DOCUMENTATION

[MX10003 Installation Overview | 73](#)

[Tools Required to the Install MX10003 Router in a Rack | 78](#)

[Installing the MX10003 Router in a Rack | 78](#)

MX10003 Site Guidelines and Requirements

IN THIS SECTION

- [MX10003 Router Environmental Specifications | 50](#)
- [MX10003 Router Grounding Specifications | 51](#)
- [MX10003 Router Clearance Requirements for Airflow and Hardware Maintenance | 53](#)
- [MX10003 Router Physical Specifications | 54](#)
- [MX10003 Router Rack Requirements | 56](#)

MX10003 Router Environmental Specifications

Table 20 on page 50 specifies the environmental specifications required for normal router operation. In addition, the site should be as dust-free as possible.

Table 20: Router Environmental Specifications

Description	Value
Altitude	No performance degradation up to 10,000 ft (3048 m)
Relative humidity	Normal operation ensured in relative humidity range of 5% through 90%, noncondensing
Temperature	Normal operation ensured in temperature range of 32°F (0°C) through 104°F (40°C) Nonoperating storage temperature in shipping container: -40°F (-40°C) through 158°F (70°C)
Seismic	Designed to meet Telcordia Technologies Zone 4 earthquake requirements
Maximum thermal output (500 W)	1705 BTU/hour

NOTE: Install the router only in restricted areas, such as dedicated equipment rooms and equipment closets, in accordance with Articles 110-16, 110-17, and 110-18 of the National Electrical Code, ANSI/NFPA 70.

SEE ALSO

[Routine Maintenance Procedures for MX10003 Routers | 105](#)

General Safety Guidelines for Juniper Networks Devices

[General Safety Warnings for Juniper Networks Devices | 171](#)

MX10003 Router Grounding Specifications

IN THIS SECTION

- [Grounding Points Specifications | 51](#)
- [Grounding Cable Lug Specifications | 52](#)
- [Grounding Cable Specifications | 52](#)

Grounding Points Specifications

To meet safety and electromagnetic interference (EMI) requirements and to ensure proper operation, the router must be adequately grounded before power is connected. To ground AC-powered and DC-powered routers, you must connect a grounding cable to earth ground and then attach it to the chassis grounding points by using the two screws provided.

[Figure 18 on page 52](#) shows the grounding point location on the router.

A protective earthing terminal bracket is required for connecting the chassis to earth ground. This two-holed bracket attaches on the side of the chassis through the mounting rail and provides a protective earthing terminal for the switch. The grounding points are studs sized for M4 hex screws. M4 hex screws with integrated washers are provided in the accessory kit. The grounding points are spaced at 0.75-in. (19.1-mm) centers.

Two threaded holes are provided on the front right side of the chassis for connecting the router to earth ground. The grounding points fit M5 pan head screws.

NOTE: Additional grounding is provided to an AC-powered router when you plug its power supplies into grounded AC power receptacles.

You must install the MX10003 router in a restricted-access location and ensure that the chassis is always properly grounded. The MX10003 router has a two-hole protective grounding terminal provided on the chassis. See [Figure 18 on page 52](#). We recommend that you use this protective grounding terminal as the preferred method for grounding the chassis regardless of the power supply configuration. However, if additional grounding methods are available, you can also use those methods. For example, you can use the grounding wire in the AC power cord or use the grounding terminal or lug on a DC power supply. This tested system meets or exceeds all applicable EMC regulatory requirements with the two-hole protective grounding terminal.

Figure 18: Grounding Points on the Router

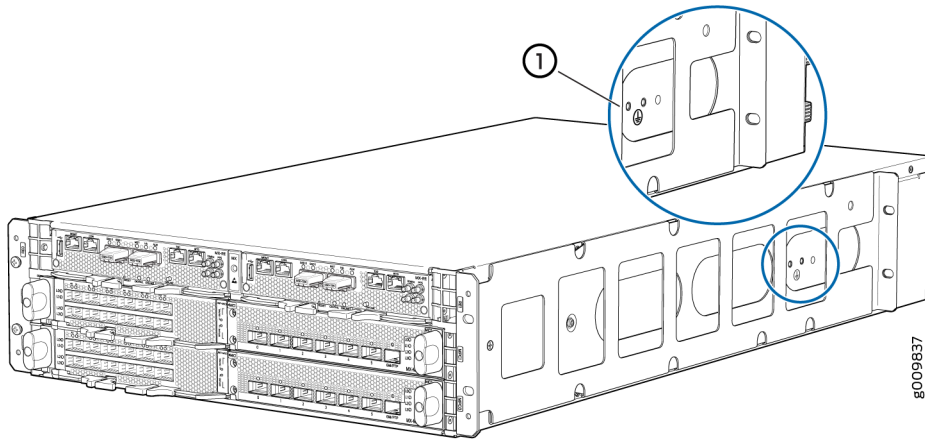

1– Grounding point

Grounding Cable Lug Specifications

The accessory box shipped with the router includes one cable lug that attaches to the grounding cable and M4 hex screws used to secure the grounding cable to the grounding points .



CAUTION: Before you install the router, a licensed electrician must attach a cable lug to the grounding and power cables that you supply. A cable with an incorrectly attached lug can damage the router.

Grounding Cable Specifications

The grounding lug required is a Panduit LCD10-14B-L or equivalent (not provided). The grounding lug accommodates 14–10 AWG (2–5.3 mm²) stranded wire. The grounding cable that you provide for the chassis must be the same size or heavier than the input wire of each power supply. Minimum recommendations are 14–10 AWG (2–5.3 mm²) stranded wire, 60° C wire, or as permitted by local code.

SEE ALSO

[Tools and Parts Required for MX10003 Router Grounding and Power Connections](#) | 82

[MX10003 Router AC Power Specifications](#) | 23

[MX10003 Router DC Power Specifications](#) | 29

MX10003 Router Clearance Requirements for Airflow and Hardware Maintenance

When planning the installation site, allow sufficient clearance around the rack (see [Figure 19 on page 53](#)):

- For the cooling system to function properly, the airflow around the chassis must be unrestricted. Allow at least 6 in. (15.2 cm) of clearance between side-cooled routers. Allow 2.8 in. (7 cm) between the side of the chassis and any non-heat-producing surface such as a wall.
- For service personnel to remove and install hardware components, there must be adequate space at the front and back of the router. At least 24 in. (61 cm) are required both in front of and behind the router. NEBS GR-63 recommends that you allow at least 30 in. (76.2 cm) in front of the rack and 24 in. (61 cm) behind the router.
- To accommodate power cable bend radius at the rear of the chassis and the interface cable bend radius at the front of the chassis, provide at least 2.75 in. (7 cm) at the rear and 3.5 in. (8.9 cm) at the front.

Figure 19: MX10003 Chassis Dimensions and Clearance Requirements

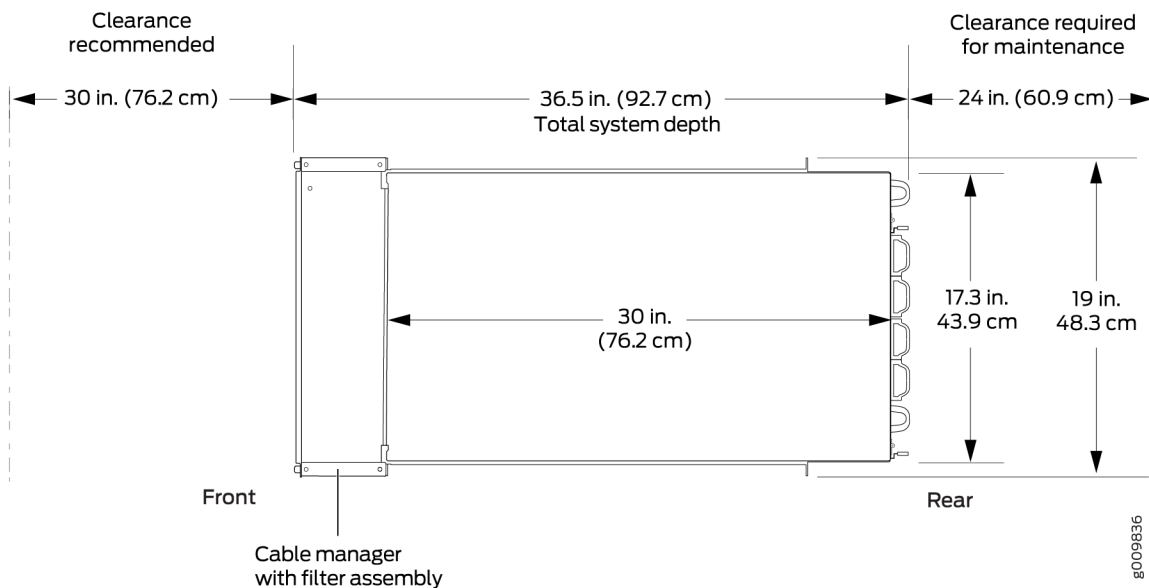

MX10003 Router Physical Specifications

Table 21 on page 54 summarizes the physical specifications for the router.

Table 21: Router Physical Specifications

Description	Weight	Width	Depth	Height
Chassis fully loaded with all FRUs	AC-powered chassis: 157.4 lb (71.4 kg)	19 in. (48.26 cm)	36.5 in. (92.7 cm) with the cable management brackets, air filter unit, and handles for fans and power supplies	5.21 in. (13.23 cm; 3 U)
	DC-powered chassis: 163.4 lb (74.11 kg)	19 in. (48.26 cm)	38.5 in. (97.79 cm) with the cable management brackets, air filter unit, and handles for fans and power supplies	5.21 in. (13.23 cm; 3 U)
Chassis without any FRUs	50 lb (22.68 kg)	19 in. (48.26 cm)	30 in. (76.2 cm) without the cable management brackets, air filter unit, and handles for fans and power supplies	5.21 in. (13.23 cm; 3 U)
Air filter unit along with cable management brackets	5.51 lb (2.5 kg)	19 in. (48.26 cm)	5.43 in. (13.79 cm)	5.19 in. (13.18 cm)
MPC (model number: JNP10003-LC2103; without any MIC in MIC1 slot)	30 lb (13.61 kg)	16.5 in. (41.91 cm)	22.37 in. (56.82 cm)	1.65 in. (4.19 cm)

Table 21: Router Physical Specifications (Continued)

Description	Weight	Width	Depth	Height
MPC (model number: JNP10003-LC2103-V2; without any MIC in MIC1 slot)	30 lb (13.61 kg)	16.5 in. (41.91 cm)	22.37 in. (56.82 cm)	1.65 in. (4.19 cm)
MIC (model number: JNP-MIC1)	3 lb (1.36 kg)	7.77 in. (19.73 cm)	8.97 in (22.78 cm)	1.65 in. (4.19 cm)
Routing and Control Board (RCB)	7.5 lb (3.4 kg)	7.98 in. (20.27 cm)	22.12 in. (56.18 cm)	1.66 in. (4.21 cm)
fan module	1.5 lb (0.68 kg)	2.46 in. (6.25 cm)	9.27 in. (23.54 cm)	4.99 in. (12.67 cm)
AC power supply	3.4 lb (1.54 kg)	3.53 in. (8.67 cm)	9.26 in. (23.52 cm)	1.63 in. (4.14 cm)
DC power supply	4.4 lb (1.99 kg)	3.53 in. (8.67 cm)	10.8 in. (27.43 cm)	1.63 in. (4.14 cm)

NOTE: For router maintenance and to accommodate power cable bend radius, allow at least 30 in. (76.2 cm) in front of the rack and 24 in. (61 cm) behind the router (see "[MX10003 Router Clearance Requirements for Airflow and Hardware Maintenance](#)" on page 53).

SEE ALSO

[MX10003 Router Hardware Overview](#) | 3

[MX10003 Chassis Description](#) | 10

MX10003 Router Rack Requirements

The router can be installed in a standard 19-in. rack. Many types of racks are acceptable, including four-post (telco) racks and open-frame racks. [Table 22 on page 56](#) summarizes rack requirements and specifications for the router.

Table 22: Router Rack Requirements and Specifications

Rack Requirement	Guidelines
Rack type and mounting bracket hole spacing	<p>Use a four-post rack. You can mount the router on any four-post rack that provides bracket holes or hole patterns spaced at 1 U (1.75-in./4.44-cm) increments and that meets the size and strength requirements specified in this table.</p> <p>A U is the standard rack unit defined in <i>Cabinets, Racks, Panels, and Associated Equipment</i> (document number EIA-310-D) published by the Electronics Components Industry Association (http://www.ecianow.org/).</p>

Table 22: Router Rack Requirements and Specifications (*Continued*)

Rack Requirement	Guidelines
Rack size and strength	<ul style="list-style-type: none"> • Ensure that the rack is a 19-in. wide as defined in <i>Cabinets, Racks, Panels, and Associated Equipment</i> (document number EIA-310-D) published by the Electronics Components Industry Association (http://www.ecianow.org/). • Ensure that the rack is of one of the following standard depths: <ul style="list-style-type: none"> • 30.0 in. (762 mm) • 31.5 in. (800 mm) • The rack rails must be spaced widely enough to accommodate the router chassis's external dimensions (see "MX10003 Router Physical Specifications To be reviewed for Vertex." on page 54). The outer edges of the mounting brackets extend the width to 19 in. (48.3 cm). The spacing of rails and adjacent racks must also allow for the clearances around the router and rack that are specified in "MX10003 Router Clearance Requirements for Airflow and Hardware Maintenance" on page 53. • The router ships with the front-mounting brackets fixed in the front-mount position on the chassis. You can move the rear-mounting brackets based on the depth of the rack. • The chassis height of 5.21 in. (13.23 cm) is approximately 3 U (rack unit). • The rack must be strong enough to support the weight of the fully configured router, up to 164 lb (74.2 kg). • Either end of the router must be mounted flush with the rack and still be adjustable for racks with different depths. The front and rear rack rails must be spaced between 28 in. (71.1 cm) and 36 in. (91.4 cm) front to back. • Ensure that the spacing of rails and adjacent racks allows for the proper clearance around the router and rack as specified in "MX10003 Router Clearance Requirements for Airflow and Hardware Maintenance" on page 53.

Table 22: Router Rack Requirements and Specifications *(Continued)*

Rack Requirement	Guidelines
Rack connection to the building structure	<ul style="list-style-type: none"> • Secure the rack to the building structure. • If earthquakes are a possibility in your geographic area, secure the rack to the floor. • Secure the rack to the ceiling brackets as well as wall or floor brackets for maximum stability.

SEE ALSO

[MX10003 Installation Overview | 73](#)

[Installing the MX10003 Router in a Rack | 78](#)

MX10003 Power Planning

IN THIS SECTION

- [Calculating Power Requirements for MX10003 Router | 58](#)

Calculating Power Requirements for MX10003 Router

IN THIS SECTION

- [Power Requirements for MX10003 Components | 59](#)
- [Calculating Power Consumption for Your Configuration | 59](#)
- [Calculating System Thermal Output | 62](#)

Use the information in this topic to determine the power consumption for your router and plan the amount of power you need to provide to the router.

- ["Power Requirements for MX10003 Components" on page 59](#)
- ["Calculating Power Consumption for Your Configuration" on page 59](#)
- ["Calculating System Thermal Output" on page 62](#)

Power Requirements for MX10003 Components

[Table 23 on page 59](#) lists the power requirements for various hardware components when the router is operating under typical and maximum voltage conditions.

Table 23: Power Requirements for MX10003 Components

Component	Power Requirement at 25° C (Watts; Typical)	Power Requirement at 55° C (Watts; Maximum)
JNP-MIC1 (MIC)	80 W	85 W
JNP-MIC1-MACSEC (MIC)	110 W	120 W
JNP10003-LC2103 (MPC)	660 W	715 W
JNP10003-LC2103-V2 (MPC)	665 W	725 W
JNP10003-RE1 (RCB)	58 W	65 W
JNP-FAN-3RU (Fan module)	20 W	95 W

Calculating Power Consumption for Your Configuration

These examples use generalized values per MIC. For exact MIC power requirements, see the [MX Series Interface Module Reference](#).

The following calculations show the typical power consumption (at 25° C) for modular routers :

- Fully loaded AC-powered router with four fan modules, two MPCs, two JNP-MIC1 MICs, and two RCBs :

Router (idle at 25° C, with QSFP28 optics) with 4 fans (running at normal speed) + 2 MPC +
2 MIC + 2 RCBs=
80 W + 1320 W + 160 W + 116 W = 1676 W

Output power in watts / power supply efficiency @90% = power consumption in watts
1676 W / 0.9 = 1862 W

- Fully loaded AC-powered router with four fan modules, two MPCs, two JNP-MIC1-MACSEC MICs, and two RCBs:

Router (idle at 25° C, with QSFP28 optics) with 4 fans (running at normal speed) + 2 MPC +
2 MIC + 2 RCBs=
90 W + 1320 W + 220 W + 116 W = 1736 W

Output power in watts / power supply efficiency @90% = power consumption in watts
1736 W / 0.9 = 1929 W

The following calculations show the maximum power consumption (at 55° C) for modular routers :

- Fully loaded AC-powered router with four fan modules, two MPCs, two JNP-MIC1 MICs, and two RCBs:

Router (idle at 55° C, with QSFP28 optics) with 4 fans (running at normal speed) + 2 MPC +
2 MIC + 2 RCBs=
380 W + 1430 W + 170 W + 130 W = 2110 W

Output power in watts / power supply efficiency @90% = power consumption in watts
2110 W / 0.9 = 2345 W

- Fully loaded AC-powered router with four fan modules, two MPC, two JNP-MIC1-MACSEC MICs, and two RCBs:

Router (idle at 55° C, with QSFP28 optics) with 4 fans (running at normal speed) + 2 MPC + 2 MIC + 2 RCBs=
 $380\text{ W} + 1430\text{ W} + 240\text{ W} + 130\text{ W} = 2180\text{ W}$

Output power in watts / power supply efficiency @90% = power consumption in watts
 $2180\text{ W} / 0.9 = 2422\text{ W}$

[Table 24 on page 61](#) lists the power requirements for the fully configured routers operating under typical voltage conditions.

Table 24: MX10003 Router Power Requirements at Typical Temperature (25° C)

Fixed Chassis Configuration	Power Requirement at 25° C (Watts)	Power Requirement (Watts) with 90% Efficiency
Fully configured chassis running at high activity, with QSFP28 optics and JNP-MIC1	1676 W	1862 W
Fully configured chassis running at high activity, with QSFP28 optics and JNP-MIC1-MACSEC	1736 W	1929 W

[Table 25 on page 61](#) lists the power requirements for the fully configured routers operating under maximum voltage conditions.

Table 25: MX10003 Router Power Requirements at Maximum Temperature (55° C)

Fixed Chassis Configuration	Power Requirement at 55° C (Watts)	Power Requirement (Watts) with 90% Efficiency
Fully configured chassis running at high activity, with QSFP28 optics and JNP-MIC1	2110 W	2344 W
Fully configured chassis running at high activity, with QSFP28 optics and JNP-MIC1-MACSEC	2180 W	2422 W

[Table 26 on page 62](#) shows how much power is available with AC and DC power supplies.

Table 26: Total Power

Number of Power Supplies	AC	DC
1	1600 W	1100 W
2	3200 W	2200 W
3	4800 W	3300 W
4	6400 W	4400 W
5	8000 W	5500 W
6	9600 W	6600 W

Calculating System Thermal Output

After you have calculated the power consumption for your configuration, you can use that information to determine the system thermal output (BTUs per hour). To do so, multiply the power consumption in watts by 3.41.

For example, in [Table 24 on page 61](#) we calculated the power consumption for a fully configured chassis running at high activity, with QSFP28 optics, and JNP-MIC1 at 25° C typical temperature to be 1676 W. Using that information we can calculate the system thermal output for the configuration:

Power consumption in watts * 3.41 = system thermal output in BTU/hr
 1,676 W * 3.41 = 5,715.16 BTU/hr

SEE ALSO

[MX10003 AC Power System Description | 21](#)

[Routine Maintenance Procedures for MX10003 Routers | 105](#)

[Replacing an MX10003 AC Power Supply | 118](#)

[AC Power Cord Specifications for MX10003 Routers | 24](#)

[AC Power Circuit Breaker Requirements for the MX10003 Router | 24](#)

[General Safety Guidelines and Warnings | 169](#)

[General Electrical Safety Guidelines and Warnings | 192](#)

[Prevention of Electrostatic Discharge Damage | 173](#)

MX10003 Network Cable and Transceiver Planning

IN THIS SECTION

- [Calculating Power Budget and Power Margin for Fiber-Optic Cables | 63](#)
- [CB-RE and RCB Interface Cable and Wire Specifications for MX Series Routers | 66](#)
- [Fiber-Optic Cable Signal Loss, Attenuation, and Dispersion | 67](#)

Calculating Power Budget and Power Margin for Fiber-Optic Cables

IN THIS SECTION

- [Calculate Power Budget for Fiber-Optic Cables | 64](#)
- [How to Calculate Power Margin for Fiber-Optic Cables | 64](#)

Use the information in this topic and the specifications for your optical interface to calculate the power budget and power margin for fiber-optic cables.

TIP: You can use the [Hardware Compatibility Tool](#) to find information about the pluggable transceivers supported on your Juniper Networks device.

To calculate the power budget and power margin, perform the following tasks:

Calculate Power Budget for Fiber-Optic Cables

To ensure that fiber-optic connections have sufficient power for correct operation, you need to calculate the link's power budget (P_B), which is the maximum amount of power it can transmit. When you calculate the power budget, you use a worst-case analysis to provide a margin of error, even though all the parts of an actual system do not operate at the worst-case levels. To calculate the worst-case estimate of P_B , you assume minimum transmitter power (P_T) and minimum receiver sensitivity (P_R):

$$P_B = P_T - P_R$$

The following hypothetical power budget equation uses values measured in decibels (dB) and decibels referred to one milliwatt (dBm):

$$P_B = P_T - P_R$$

$$P_B = -15 \text{ dBm} - (-28 \text{ dBm})$$

$$P_B = 13 \text{ dB}$$

How to Calculate Power Margin for Fiber-Optic Cables

After calculating a link's P_B , you can calculate the power margin (P_M), which represents the amount of power available after subtracting attenuation or link loss (LL) from the P_B . A worst-case estimate of P_M assumes maximum LL:

$$P_M = P_B - LL$$

P_M greater than zero indicates that the power budget is sufficient to operate the receiver.

Factors that can cause link loss include higher-order mode losses, modal and chromatic dispersion, connectors, splices, and fiber attenuation. [Table 27 on page 64](#) lists an estimated amount of loss for the factors used in the following sample calculations. For information about the actual amount of signal loss caused by equipment and other factors, refer to vendor documentation.

Table 27: Estimated Values for Factors Causing Link Loss

Link-Loss Factor	Estimated Link-Loss Value
Higher-order mode losses	Single mode—None
	Multimode—0.5 dB

Table 27: Estimated Values for Factors Causing Link Loss (Continued)

Link-Loss Factor	Estimated Link-Loss Value
Modal and chromatic dispersion	Single mode—None Multimode—None, if product of bandwidth and distance is less than 500 MHz-km
Faulty connector	0.5 dB
Splice	0.5 dB
Fiber attenuation	Single mode—0.5 dB/km Multimode—1 dB/km

The following sample calculation for a 2-km-long multimode link with a P_B of 13 dB uses the estimated values from [Table 27 on page 64](#). This example calculates LL as the sum of fiber attenuation (2 km @ 1 dB/km, or 2 dB) and loss for five connectors (0.5 dB per connector, or 2.5 dB) and two splices (0.5 dB per splice, or 1 dB) as well as higher-order mode losses (0.5 dB). The P_M is calculated as follows:

$$P_M = P_B - LL$$

$$P_M = 13 \text{ dB} - 2 \text{ km (1 dB/km)} - 5 (0.5 \text{ dB}) - 2 (0.5 \text{ dB}) - 0.5 \text{ dB}$$

$$P_M = 13 \text{ dB} - 2 \text{ dB} - 2.5 \text{ dB} - 1 \text{ dB} - 0.5 \text{ dB}$$

$$P_M = 7 \text{ dB}$$

The following sample calculation for an 8-km-long single-mode link with a P_B of 13 dB uses the estimated values from [Table 27 on page 64](#). This example calculates LL as the sum of fiber attenuation (8 km @ 0.5 dB/km, or 4 dB) and loss for seven connectors (0.5 dB per connector, or 3.5 dB). The pP_M is calculated as follows:

$$P_M = P_B - LL$$

$$P_M = 13 \text{ dB} - 8 \text{ km (0.5 dB/km)} - 7(0.5 \text{ dB})$$

$$P_M = 13 \text{ dB} - 4 \text{ dB} - 3.5 \text{ dB}$$

$$P_M = 5.5 \text{ dB}$$

In both the examples, the calculated P_M is greater than zero, indicating that the link has sufficient power for transmission and does not exceed the maximum receiver input power.

CB-RE and RCB Interface Cable and Wire Specifications for MX Series Routers

Table 28 on page 66 lists the specifications for the cables that connect to management ports and the wires that connect to the alarm relay contacts.

NOTE: In routers where the Routing Engine (RE) and Control Board (CB) are integrated into a single board, a CB-RE is known as Routing and Control Board (RCB). The RCB is a single FRU that provides RE and CB functionality.

Table 28: Cable and Wire Specifications for Routing Engine and RCB Management and Alarm Interfaces

Port	Cable Specification	Maximum Length	Router Receptacle
Routing Engine console or auxiliary interface	RS-232 (EIA-232) serial cable	1.83 m	RJ-45 socket
Routing Engine Ethernet interface	Category 5 cable or equivalent suitable for 100Base-T operation	100 m	RJ-45 autosensing
Alarm relay contacts	Wire with gauge between 28-AWG and 14-AWG (0.08 and 2.08 mm ²)	None	—

NOTE: We no longer include the RJ-45 console cable with the DB-9 adapter as part of the device package. If the console cable and adapter are not included in your device package, or if you need a different type of adapter, you can order the following separately:

- RJ-45 to DB-9 adapter (JNP-CBL-RJ45-DB9)

- RJ-45 to USB-A adapter (JNP-CBL-RJ45-USBA)
- RJ-45 to USB-C adapter (JNP-CBL-RJ45-USBC)

If you want to use RJ-45 to USB-A or RJ-45 to USB-C adapter you must have X64 (64-Bit) Virtual COM port (VCP) driver installed on your PC. See, <https://ftdichip.com/drivers/vcp-drivers/> to download the driver.

Fiber-Optic Cable Signal Loss, Attenuation, and Dispersion

IN THIS SECTION

- [Signal Loss in Multimode and Single-Mode Fiber-Optic Cable | 67](#)
- [Attenuation and Dispersion in Fiber-Optic Cable | 68](#)

Signal Loss in Multimode and Single-Mode Fiber-Optic Cable

Multimode fiber is large enough in diameter to allow rays of light to reflect internally (bounce off the walls of the fiber). Interfaces with multimode optics typically use LEDs as light sources. However, LEDs are not coherent sources. They spray varying wavelengths of light into the multimode fiber, which reflects the light at different angles. Light rays travel in jagged lines through a multimode fiber, causing signal dispersion. When light traveling in the fiber core radiates into the fiber cladding, higher-order mode loss results. Together these factors limit the transmission distance of multimode fiber compared with single-mode fiber.

Single-mode fiber is so small in diameter that rays of light can reflect internally through one layer only. Interfaces with single-mode optics use lasers as light sources. Lasers generate a single wavelength of light, which travels in a straight line through the single-mode fiber. Compared with multimode fiber, single-mode fiber has a higher bandwidth and can carry signals for longer distances.

Exceeding the maximum transmission distances can result in significant signal loss, which causes unreliable transmission.

Attenuation and Dispersion in Fiber-Optic Cable

Correct functioning of an optical data link depends on modulated light reaching the receiver with enough power to be demodulated correctly. *Attenuation* is the reduction in power of the light signal as it is transmitted. Attenuation is caused by passive media components such as cables, cable splices, and connectors. Although attenuation is significantly lower for optical fiber than for other media, it still occurs in both multimode and single-mode transmission. An efficient optical data link must have enough light available to overcome attenuation.

Dispersion is the spreading of the signal over time. The following two types of dispersion can affect an optical data link:

- Chromatic dispersion—Spreading of the signal over time, resulting from the different speeds of light rays.
- Modal dispersion—Spreading of the signal over time, resulting from the different propagation modes in the fiber.

For multimode transmission, modal dispersion—rather than chromatic dispersion or attenuation—usually limits the maximum bit rate and link length. For single-mode transmission, modal dispersion is not a factor. However, at higher bit rates and over longer distances, chromatic dispersion rather than modal dispersion limits maximum link length.

An efficient optical data link must have enough light to exceed the minimum power that the receiver requires to operate within its specifications. In addition, the total dispersion must be less than the limits specified for the type of link in Telcordia Technologies document GR-253-CORE (Section 4.3) and International Telecommunications Union (ITU) document G.957.

When chromatic dispersion is at the maximum allowed, its effect can be considered as a power penalty in the power budget. The optical power budget must allow for the sum of component attenuation, power penalties (including those from dispersion), and a safety margin for unexpected losses.

MX10003 Management and Console Port Specifications and Pinouts

IN THIS SECTION

- [RJ-45 Connector Pinouts for MX Series CB-RE or RCB Auxillary and Console Ports | 69](#)

RJ-45 Connector Pinouts for MX Series CB-RE or RCB Auxiliary and Console Ports

The ports—labeled—**AUX** and **CONSOLE**—on the Control Board and Routing Engine (CB-RE) or the Routing and Control Board (RCB) are asynchronous serial interfaces that accept an RJ-45 connector. The ports connect the Routing Engine to an auxiliary or console management device. [Table 29 on page 69](#) describes the RJ-45 connector pinout.

NOTE: In routers where the Routing Engine and Control Board (CB) are integrated into a single board, a CB-RE is known as Routing and Control Board (RCB). The RCB is a single FRU that provides Routing Engine and CB functionality.

Table 29: RJ-45 Connector Pinout for the AUX and CONSOLE Ports

Pin	Signal	Description
1	RTS	Request to Send
2	DTR	Data Terminal Ready
3	TXD	Transmit Data
4	Ground	Signal Ground
5	Ground	Signal Ground
6	RXD	Receive Data
7	DSR/DCD	Data Set Ready

Table 29: RJ-45 Connector Pinout for the AUX and CONSOLE Ports (*Continued*)

Pin	Signal	Description
8	CTS	Clear to Send

RJ-45 Connector Pinouts for an MX Series CB-RE or RCB Management Port

The port on the Control Board and Routing Engine (CB-RE; Routing and Control Board (RCB)) labeled **MGMT** is an autosensing 10/100/1000-Mbps Ethernet RJ-45 receptacle that accepts an Ethernet cable for connecting the Routing Engine to a management LAN (or other device that supports out-of-band management).

NOTE: In routers where the Routing Engine and Control Board (CB) are integrated into a single board, a CB-RE is known as Routing and Control Board (RCB). The RCB is a single FRU that provides Routing Engine and CB functionality.

Table 30 on page 70 describes the RJ-45 connector pinout.

Table 30: RJ-45 Management Port Connector Pinouts for the CB-RE or RCB MGMT Port

Pin	Signal	Description
1	TRP1+	Transmit/receive data pair 1
2	TRP1-	Transmit/receive data pair 1
3	TRP2+	Transmit/receive data pair 2
4	TRP3+	Transmit/receive data pair 3
5	TRP3-	Transmit/receive data pair 3

Table 30: RJ-45 Management Port Connector Pinouts for the CB-RE or RCB MGMT Port (Continued)

Pin	Signal	Description
6	TRP2-	Transmit/receive data pair 2
7	TRP4+	Transmit/receive data pair 4
8	TRP4-	Transmit/receive data pair 4

3

CHAPTER

Initial Installation and Configuration

[MX10003 Installation Overview | 73](#)

[Tools and Parts Required to Unpack the MX10003 Router | 74](#)

[Unpacking the MX10003 Router | 74](#)

[Verifying the MX10003 Router Parts Received | 75](#)

[Installing the MX10003 | 78](#)

[Connecting the MX10003 to Power | 81](#)

[Connecting the MX10003 to the Network | 89](#)

[Powering On and Off the MX10003 | 96](#)

[Initially Configuring the MX10003 Router | 99](#)

MX10003 Installation Overview

To install the router:

1. Prepare your installation site.
See ["MX10003 Site Preparation Checklist"](#) on page 48.
2. Review the safety guidelines and warnings:
 - See ["General Safety Guidelines and Warnings"](#) on page 169.
 - See ["General Safety Warnings for Juniper Networks Devices"](#) on page 171.
3. Unpack the router and verify the parts:
 - a. See ["Unpacking the MX10003 Router"](#) on page 74.
 - b. See ["Verifying the MX10003 Router Parts Received"](#) on page 75.
4. (*Optional*) Remove components from the MX10003 router chassis before installing it in a rack.
See individual topics listed in *Removing, Installing, and Upgrading Components* for removing components.
5. Install the router onto the rack.
See ["Installing the MX10003 Router in a Rack"](#) on page 78.
6. (*Optional*; Required only if you have removed the components from the router in step 4) Reinstall components in the MX10003 router after installing the chassis in a rack.
See individual topics listed in *Removing, Installing, and Upgrading Components* for installing components.
7. Connect cables to the network and external devices.
See ["Connecting the MX10003 Router to External Devices and Cables"](#) on page 90.
8. Connect the grounding cable.
See ["Grounding the MX10003 Router"](#) on page 82.
9. Connect the AC power cord or DC power cables:
 - See ["Connecting Power to an AC-Powered MX10003 Router"](#) on page 84.
 - See ["Connecting Power to a DC-Powered MX10003 Router"](#) on page 86.
10. Power on the router:
 - See ["Powering On an AC-Powered MX10003 Router"](#) on page 96.
 - See ["Powering On a DC-Powered MX10003 Router"](#) on page 97.
11. Install the air filter unit.
See ["Replacing the MX10003 Air Filter Unit"](#) on page 107.
12. Perform the initial system configuration.

See "Initially Configuring the MX10003 Router" on page 99.

RELATED DOCUMENTATION

[MX10003 Router Rack Requirements | 56](#)

[MX10003 Router Clearance Requirements for Airflow and Hardware Maintenance | 53](#)

Tools and Parts Required to Unpack the MX10003 Router

To unpack the router and prepare for installation, you need the following tools:

- Phillips (+) screwdriver, number 1, 2, and 3
- 1/2-in. or 13-mm open-end or socket wrench to remove bracket bolts from the shipping pallet
- Blank panels to cover any slots not occupied by a component

RELATED DOCUMENTATION

[Verifying the MX10003 Router Parts Received | 75](#)

[MX10003 Field-Replaceable Units | 8](#)

[Unpacking the MX10003 Router | 74](#)

Unpacking the MX10003 Router

The router is shipped in a cardboard carton and secured with foam packing material. The carton also contains an accessory box and quick start instructions.

NOTE: The router is maximally protected inside the shipping carton. Do not unpack it until you are ready to begin installation.

To unpack the router:

1. Move the shipping carton to a staging area as close to the installation site as possible, but where you have enough room to remove the router.
2. Position the carton so that the arrows are pointing up.
3. Open the top flaps on the shipping carton.
4. Remove the accessory box, and verify the contents against the parts inventory on the label attached to the carton.
5. Pull out the packing material holding the router in place.
6. Verify the contents of the carton against the packing list included with the router.
7. Save the shipping carton and packing materials in case you later need to move or ship the router.

RELATED DOCUMENTATION

[MX10003 Site Preparation Checklist | 48](#)

[Tools and Parts Required to Unpack the MX10003 Router | 74](#)

[Verifying the MX10003 Router Parts Received | 75](#)

Verifying the MX10003 Router Parts Received

A packing list is included in each shipment. Check the parts in the shipment against the items on the packing list. The packing list specifies the part numbers and descriptions of each part in your order.

If any part is missing, contact a customer service representative.

A fully configured router contains the router chassis with installed components, listed in [Table 31 on page 75](#), and an accessory box, which contains the parts listed in [Table 32 on page 76](#). The parts shipped with your router can vary depending on the configuration you ordered.

Table 31: Parts List for a Fully Configured Router

Component	Quantity
Chassis	1
RCB	2

Table 31: Parts List for a Fully Configured Router (Continued)

Component	Quantity
MPC	2
MIC	2
AC or DC power supply	6
Fan module	4
Air filter	1
Quick start installation instructions	1
Blank panel for slots without components installed	One blank panel for each slot not occupied by a component

Table 32: Accessory Box Parts List

Part	Quantity
Screws to secure the ground cable lug	2
DC power fork terminal lugs, 16-14 AWG, sized for #6 screw	12
USB flash drive with Junos OS	1
Juniper Networks Product Warranty	1
End User License Agreement	1
3 in. x 5 in. pink bag	2

Table 32: Accessory Box Parts List (Continued)

Part	Quantity
9 in. x 12 in. pink bag, ESD	2
Accessory box, 19 in. x 12 in. x 3 in.	1
Ethernet cable, RJ-45 to DB-9	1
ESD wrist strap with cable	1
SFP transceiver dust cover	1
QSFP transceiver dust cover	1
Screws to assemble the cable manager with the rack mounting kit	4
Cable management bracket	2

RELATED DOCUMENTATION

[MX10003 Site Preparation Checklist | 48](#)

[MX10003 Installation Overview | 73](#)

[Tools and Parts Required to Unpack the MX10003 Router | 74](#)

[Unpacking the MX10003 Router | 74](#)

Installing the MX10003

IN THIS SECTION

- [Tools Required to the Install MX10003 Router in a Rack | 78](#)
- [Installing the MX10003 Router in a Rack | 78](#)

Tools Required to the Install MX10003 Router in a Rack

To install the router, you need the following tools and parts:

- Phillips (+) screwdriver, number 2
- ESD grounding wrist strap

SEE ALSO

| [MX10003 Site Preparation Checklist | 48](#)

Installing the MX10003 Router in a Rack

To install the router in a four-post rack:



CAUTION: If you are installing more than one router in a rack, install the lowest one first. Installing a router in an upper position in a rack requires a lift.



CAUTION: Before front-mounting the router in a rack, have a qualified technician verify that the rack is strong enough to support the router's weight and is adequately supported at the installation site.



CAUTION: Lifting the chassis and mounting it in a rack requires two people (one person to guide the router in place and a second person to install the screws). A fully loaded AC-powered router weighs up to 157.4 lb (71.4 kg), while a fully loaded DC-powered router weighs up to 163.4 lb (74.1 kg).

Material handling systems (such as levers, slings, lifts, and so on) must be used to lift any equipment weighs above 121.2 lb (55 kg). When this is not practical, specially trained persons or systems must be used (riggers or movers).

1. Position the router in front of the four-post rack.
2. Attach an electrostatic discharge (ESD) grounding strap to your bare wrist and to a site ESD point.
3. Using a Phillips (+) number 2 screwdriver, remove the screw on each side of the chassis that holds the rear-mounting brackets, and slide the brackets out of the chassis (see [Figure 20 on page 79](#)). Keep the brackets safely to be used in later stage.

The rear-mounting brackets on each side of the chassis are movable. You can adjust the brackets according to the depth of the rack. However, the front-mounting brackets on each side of the chassis are fixed to the chassis.

Figure 20: Removing the Rear-Mounting Brackets

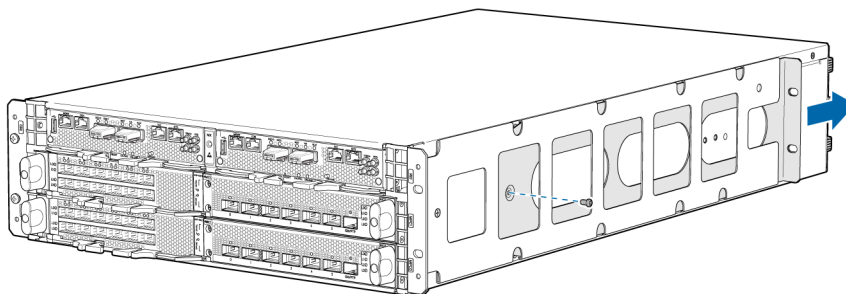

800964Z

4. Install the cable management brackets on each side of the front of the chassis, and secure each bracket with screws at the bottom and top of the bracket (see [Figure 21 on page 80](#)).

Figure 21: Installing the Cable Management Brackets

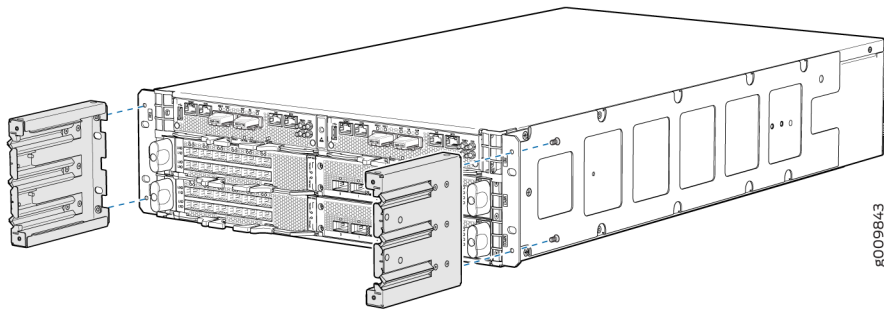

5. With one person on each side, hold on to the bottom of the chassis and carefully lift it so that the mounting brackets contact the rack rails.
6. Carefully slide the router onto the mounting brackets until the front-mounting brackets attached to the chassis contact the rack rails (see [Figure 22 on page 80](#)). The mounting brackets ensure that the holes in the front-mounting brackets attached to the chassis align with the holes in the rack rails.

Figure 22: Installing the Router in a Four-Post Rack

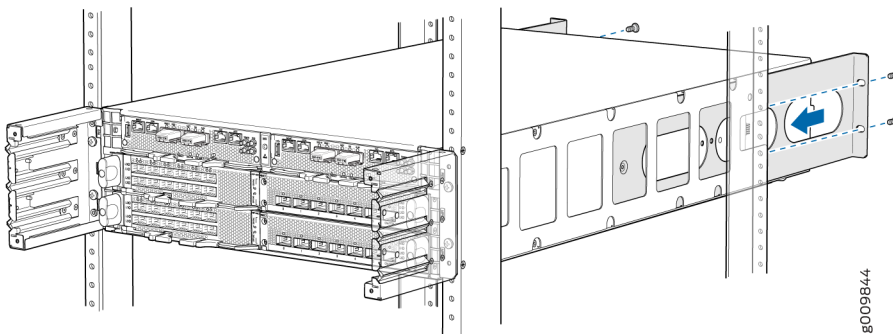

7. Install mounting screws into each of the open front-mounting holes aligned with the rack, starting from the bottom, and secure them tightly.
8. On the rear of the chassis, slide the rear-mounting brackets on either side of the chassis until the rear-mounting brackets contact the rack rails.
9. Install mounting screws into each of the open rear-mounting holes aligned with the rack, starting from the bottom, and secure them tightly.
10. Visually inspect the alignment of the chassis. If the chassis is installed properly in the rack, all the mounting screws on one side of the rack are aligned with the mounting screws on the opposite side and the router is level. [Figure 23 on page 81](#) shows the router fully secured and installed in a four-post rack.

Figure 23: Router Installed in the Rack

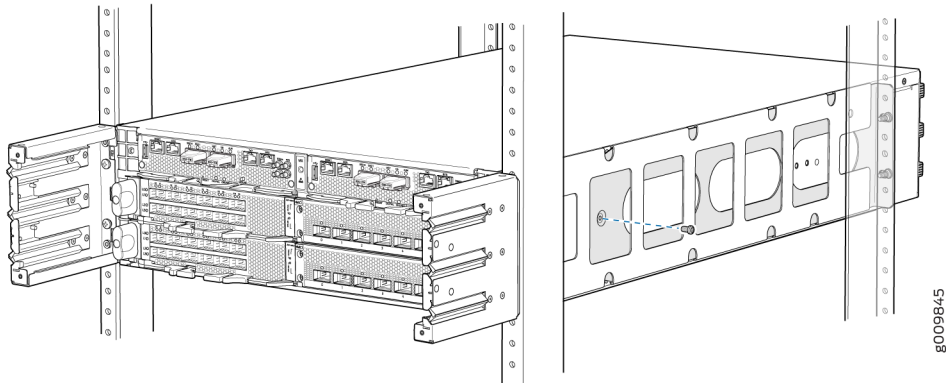

11. Install the air filter unit. See ["Replacing the MX10003 Air Filter Unit" on page 107.](#)

SEE ALSO

[MX10003 Site Preparation Checklist | 48](#)

[General Safety Guidelines and Warnings | 169](#)

[General Electrical Safety Guidelines and Warnings | 192](#)

[Prevention of Electrostatic Discharge Damage | 173](#)

Connecting the MX10003 to Power

IN THIS SECTION

- [Tools and Parts Required for MX10003 Router Grounding and Power Connections | 82](#)
- [Grounding the MX10003 Router | 82](#)
- [Connecting Power to an AC-Powered MX10003 Router | 84](#)
- [Connecting Power to a DC-Powered MX10003 Router | 86](#)

Tools and Parts Required for MX10003 Router Grounding and Power Connections

To ground and provide power to the router, you need the following tools and parts:

- Phillips (+) screwdrivers, numbers 1 and 2
- Socket nutdriver
- 2.5-mm flat-blade (-) screwdriver
- Torque-controlled driver, with a maximum torque capacity of 6 lb-in. (0.68 Nm), for tightening screws to terminals on each power supply on a DC-powered router



CAUTION: The maximum torque rating of the terminal screws on the DC power supply is 6 lb-in. (0.7 Nm). The terminal screws might be damaged if excessive torque is applied. Use only a torque-controlled driver to tighten screws on the DC power supply terminals. Use an appropriately sized driver, with a maximum torque capacity of 6 lb-in. or less. Ensure that the driver is undamaged and properly calibrated and that you have been trained in its use. You may want to use a driver that is designed to prevent overtorque when the preset torque level is achieved.

- Wire cutters
- Electrostatic discharge (ESD) grounding wrist strap

SEE ALSO

[MX10003 Router Grounding Specifications | 51](#)

[General Safety Guidelines and Warnings | 169](#)

[General Electrical Safety Guidelines and Warnings | 192](#)

[Prevention of Electrostatic Discharge Damage | 173](#)

Grounding the MX10003 Router

You ground the router by connecting a grounding cable to earth ground and then attaching it to the chassis grounding points by using two M5 pan head screws. [Figure 24 on page 83](#) shows the grounding point location on the chassis. You must provide the grounding cables (the cable lugs are supplied with

the router). For grounding cable specifications, see ["MX10003 Router Grounding Specifications"](#) on page 51.

Figure 24: Grounding Points on the MX10003 Router

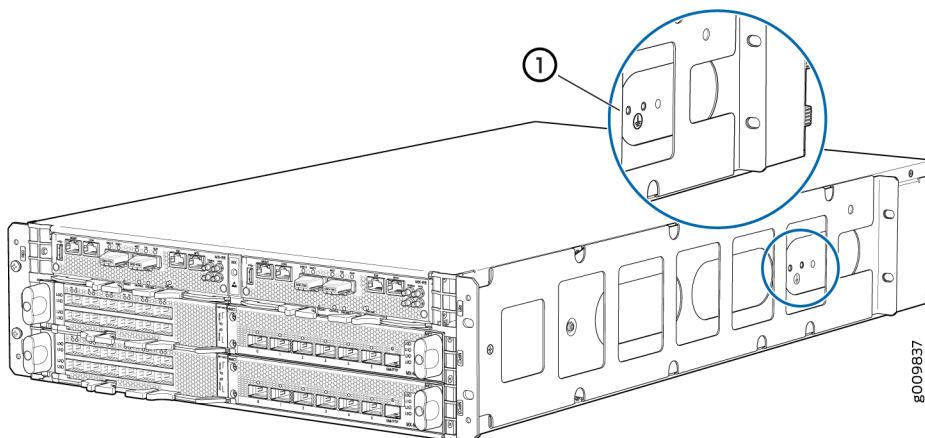

1– Grounding point

To ground the router:

1. Verify that a licensed electrician has attached the cable lug provided with the router to the grounding cable.
2. Attach an electrostatic discharge (ESD) grounding strap to your bare wrist, and connect the strap to an approved site ESD grounding point. See the instructions for your site.
3. Ensure that all grounding surfaces are clean and brought to a bright finish before grounding connections are made.
4. Connect the grounding cable to a proper earth ground.
5. Detach the ESD grounding strap from the site ESD grounding point.
6. Attach an ESD grounding strap to your bare wrist and connect the strap to one of the ESD points on the chassis.
7. Place the grounding cable lug over the grounding points on the chassis.
8. Secure the grounding cable lug with the screws. The holes are sized for M5 pan head screws (see [Figure 25 on page 84](#)).
9. Dress the grounding cable, and verify that it does not touch or block access to router components, and that it does not drape where people could trip on it.

Figure 25: Connecting Grounding lugs to the MX10003 Router

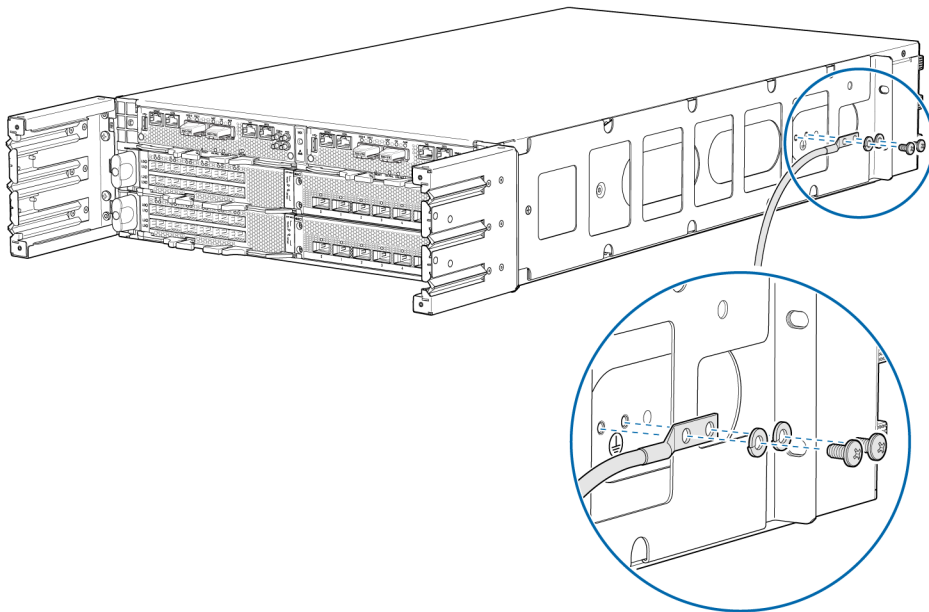

8009839

SEE ALSO

[General Safety Guidelines and Warnings | 169](#)

[General Electrical Safety Guidelines and Warnings | 192](#)

[Prevention of Electrostatic Discharge Damage | 173](#)

Connecting Power to an AC-Powered MX10003 Router



CAUTION: Do not mix AC and DC power supplies within the same router. Damage to the router might occur.

You connect AC power to the router by attaching power cords from the AC power sources to the AC appliance inlets located on the power supplies.

To connect the AC power cords to the router for each power supply:

1. Locate power cords that have a plug appropriate for your geographic location. For more information, see "[AC Power Cord Specifications for MX10003 Routers](#)" on page 24.

2. Attach an ESD grounding strap to your bare wrist and connect the strap to one of the ESD points on the chassis.
3. Power off the AC input appliance inlet on the power supply.
4. Connect the power cord to the power supply.
5. Insert the power cord plug into an external AC power source receptacle (see [Figure 26 on page 85](#)).

NOTE: Each power supply must be connected to a dedicated AC power feed and a dedicated customer-site circuit breaker. We recommend that you use a dedicated customer-site circuit breaker rated for 15 A (110 VAC) minimum, or as required by local code.

6. Route the power cord appropriately. Verify that the power cord does not block the air exhaust and access to router components, or drape where people could trip on it.
7. Power on the power supply at source.
8. Repeat Step 1 through Step 7 for the installing the remaining power supply.

Figure 26: Connecting AC Power to the Router

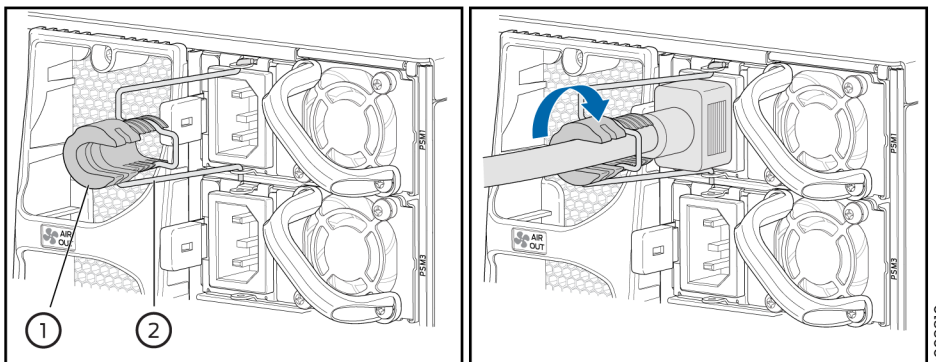

SEE ALSO

[MX10003 Router Grounding Specifications | 51](#)

[General Safety Guidelines and Warnings | 169](#)

[General Electrical Safety Guidelines and Warnings | 192](#)

[Prevention of Electrostatic Discharge Damage | 173](#)

Connecting Power to a DC-Powered MX10003 Router



CAUTION: Do not mix AC and DC power supply modules within the same device. Mixing currents can damage the device.



WARNING: Before you perform DC power procedures, ensure there is no power to the DC circuit. To ensure that all power is off, locate the circuit breaker on the panel board that services the DC circuit, switch the circuit breaker to the off position, and tape the switch handle of the circuit breaker in the off position.

You connect DC power to the router by attaching power cables from the external DC power sources to the terminal on the power supply faceplate. You must provide the power cables (the cable lugs are supplied with the router). For power cable specifications, see ["DC Power Cable Specifications for MX10003 Router" on page 31](#).

To connect the DC source power cables to the router for each power supply:

1. Switch off the dedicated customer-site circuit breakers. Ensure that the voltage across the DC power source cable leads is 0 V and that there is no chance that the cable leads might become active during installation.
2. Attach an ESD grounding strap to your bare wrist, and connect the other end of the strap to an ESD grounding point.
3. Verify that the DC power cables are correctly labeled before making connections to the power supply. In a typical power distribution scheme where the return is connected to chassis ground at the battery plant, you can use a multimeter to verify the resistance of the **-48V** and **RTN** DC cables to chassis ground:
 - The cable with very large resistance (indicating an open circuit) to chassis ground is **-48V**.
 - The cable with very low resistance (indicating a closed circuit) to chassis ground is **RTN**.



CAUTION: You must ensure that power connections maintain the proper polarity. The power source cables might be labeled **(+)** and **(-)** to indicate their polarity. There is no standard color coding for DC power cables. The color coding used by the external DC power source at your site determines the color coding for the leads on the power cables that attach to the terminal studs on each power supply.

4. Install heat-shrink tubing insulation around the power cables.

To install heat-shrink tubing:

- a. Slide the tubing over the portion of the cable where it is attached to the lug barrel. Ensure that tubing covers the end of the wire and the barrel of the lug attached to it.
- b. Shrink the tubing with a heat gun. Ensure that you heat all sides of the tubing evenly so that it shrinks around the cable tightly.

Figure 27 on page 87 shows the steps to install heat-shrink tubing.

NOTE: Do not overheat the tubing.

Figure 27: How to Install Heat-Shrink Tubing

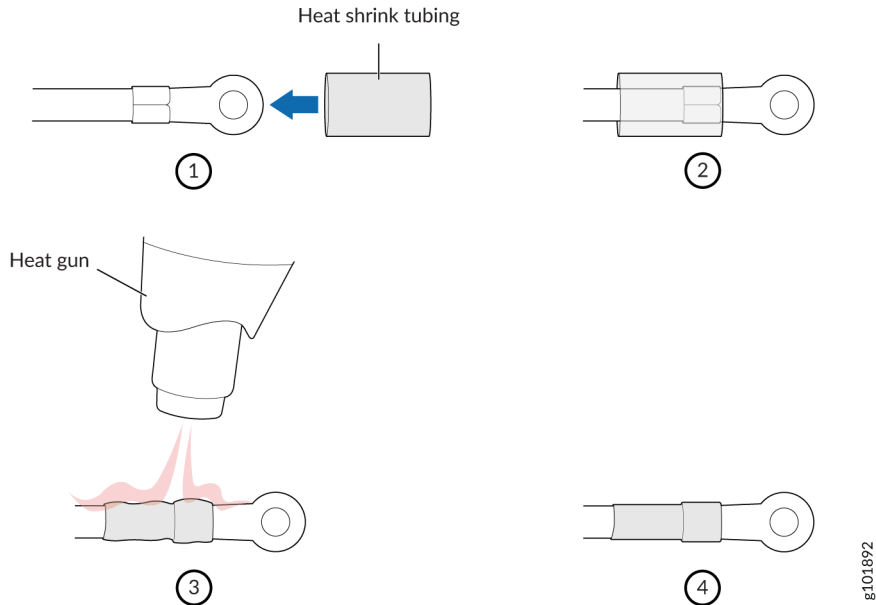

5. Remove the nuts from the terminals.
6. Secure each power cable lug to the terminal with the nuts (see [Figure 28 on page 88](#)). Apply between 5 lb-in. (0.6 Nm) and 6 lb-in. (0.7 Nm) of torque to the nuts. Do not overtighten the nuts. (Use a socket nutdriver.)
 - a. Secure the positive (+) DC source power cable lug to the **RTN** (return) terminal.
 - b. Secure the negative (-) DC source power cable lug to the **-48V** (input) terminal.



CAUTION: Ensure that each power cable lug seats flush against the surface of the terminal block as you are tightening the nuts. Ensure that each nut is properly threaded into the terminal. Applying installation torque to the nuts when improperly threaded can result in damage to the terminal.



CAUTION: You must ensure that power connections maintain the proper polarity. The power source cables might be labeled (+) and (-) to indicate their polarity. There is no standard color coding for DC power cables. The color coding used by the external DC power source at your site determines the color coding for the leads on the power cables that attach to the terminal studs on each power supply.

NOTE: For information about connecting to DC power sources, see "[MX10003 Router DC Power Specifications](#)" on page 29.

7. Verify that the power cables are connected correctly, that they are not touching or blocking access to router components, and that they do not drape where people could trip on them.
8. Repeat Step 1 through Step 6 for installing the other power supplies.

Figure 28: Connecting DC Power to the Router

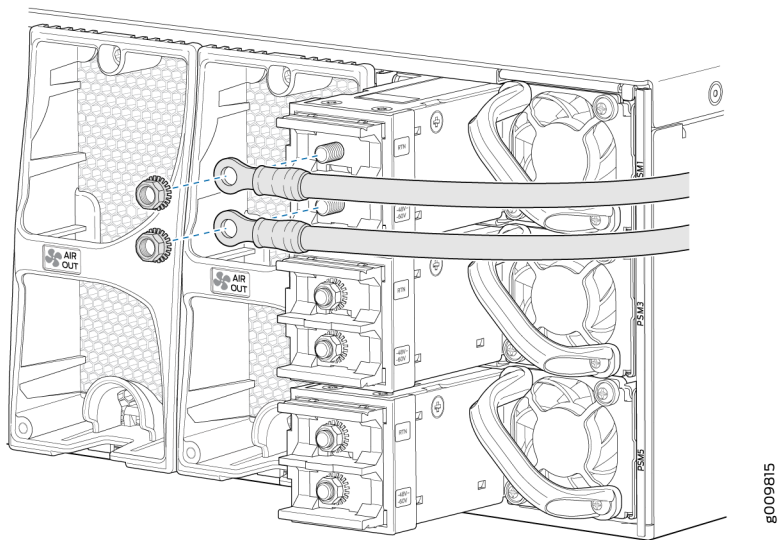

SEE ALSO

[MX10003 Router Grounding Specifications | 51](#)

[General Safety Guidelines and Warnings | 169](#)

[General Electrical Safety Guidelines and Warnings | 192](#)

[Prevention of Electrostatic Discharge Damage | 173](#)

Connecting the MX10003 to the Network

IN THIS SECTION

- [Tools and Parts Required to Connect the MX10003 Router to External Devices | 89](#)
- [Connecting the MX10003 Router to External Devices and Cables | 90](#)

Tools and Parts Required to Connect the MX10003 Router to External Devices

To connect the router to external devices, you need the following tools and parts:

- 2.5-mm flat-blade (-) screwdriver for the alarm relay contacts
- Electrostatic discharge (ESD) grounding wrist strap (provided in the accessory kit)

SEE ALSO

[Verifying the MX10003 Router Parts Received | 75](#)

[Prevention of Electrostatic Discharge Damage | 173](#)

Connecting the MX10003 Router to External Devices and Cables

IN THIS SECTION

- Connecting the Router to a Network for Out-of-Band Management | 90
- Connecting the Router to a Console Device | 91
- Connecting the Router to External Clocking and Timing Devices | 93

Figure 29 on page 90 shows the front panel of the MX10003 RCB. All the connections to the router are made through the RCBs. The external devices are connected through the RCBs.

Figure 29: Routing and Control Board (RCB) Ports

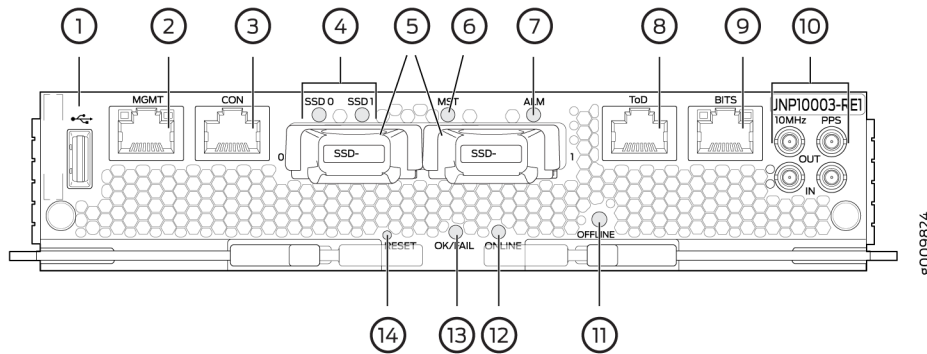

1– USB port	8– Time of day (ToD) port with LEDs
2– Management (MGMT) port	9– BITS port with LEDs
3– Console (CON) port	10– Clocking ports
4– SSD LEDs	11– OFFLINE button
5– SSD slots (0 and 1)	12– ONLINE LED
6– Primary (MST) LED	13– OK/FAIL LED
7– Alarm (ALM) LED	14– RESET button

Connecting the Router to a Network for Out-of-Band Management

To connect the RCB to a network for out-of-band management, connect an Ethernet cable with RJ-45 connectors to the **MGMT** port on the RCB interface. One Ethernet cable is provided with the router. To connect to the **MGMT** port on the RCB interface:

NOTE: Use shielded CAT5e cable for connecting the **CON** and **MGMT** ports in RCB for INDIA only.

1. Turn off power to the management device.
2. Plug one end of the Ethernet cable (Figure 2 shows the connector) into the **MGMT** port on the RCB interface.
3. Plug the other end of the cable into the network device.

Figure 30: Out-of-Band Management Cable Connector

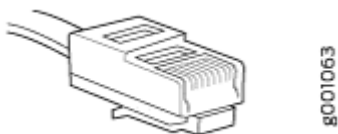

Table 33: Out-of-Band Management Port on the RCB

Callout (see Figure 29 on page 90)	Label	Description
2	MGMT	Dedicated management channel for device maintenance. It is also used by system administrators to monitor and manage the router remotely.

Connecting the Router to a Console Device

To use a system console to configure and manage the Routing Engine, connect it to the appropriate **CON** port on the RCB interface. The console port is used to connect a laptop or console terminal to configure the router (see [Figure 32 on page 92](#) and [Figure 33 on page 93](#)). The console port accepts a cable with an RJ-45 connector. One serial cable with an RJ-45 connector and a DB-9 connector is provided with the router.

NOTE: Use shielded CAT5e cable for connecting the **CON** and **MGMT** ports in RCB for INDIA only.

To connect a management console:

1. Turn off power to the console device.
2. Plug the RJ-45 end of the serial cable (see [Figure 31 on page 92](#)) into the **CON** port on the RCB interface.
3. Plug the socket DB-9 end into the device's serial port.

NOTE: For console devices, configure the serial port to the following values:

- Baud rate—9600
- Parity—N
- Data bits—8
- Stop bits—1
- Flow control—none

Figure 31: Console and Auxiliary Cable Connector

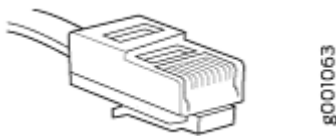

Figure 32: Connecting a router to a Management Console Through a Console Server

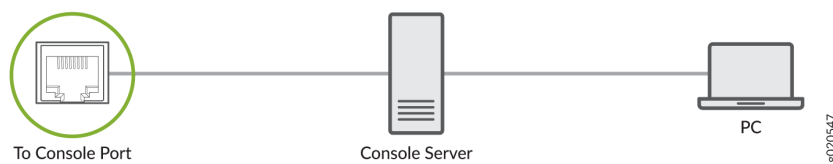

Figure 33: Connecting a router Directly to a Management Console



Table 34: Console Port on the RCB

Callout (see Figure 29 on page 90)	Label	Description
3	CON	Connect a laptop or console terminal to configure the router.

Connecting the Router to External Clocking and Timing Devices

IN THIS SECTION

- [Connecting 1-PPS and 10-MHz Timing Devices to the Router | 93](#)
- [Connecting a Time-of-Day Device to the Router | 94](#)
- [Connecting a BITS External Clocking Device to the Router | 95](#)

The router supports external clock synchronization for Synchronous Ethernet, and external inputs.

Connecting 1-PPS and 10-MHz Timing Devices to the Router

The router has two 2x1 DIN 1.0/2.3 right angle connectors that support 1-PPS-IN, 1-PPS-OUT, 10-MHz-IN, and 10-MHz-OUT timing ports.

NOTE: MX10003 can be configured as a timing primary or a client device. If the MX10003 is configured as a timing primary device, the router gets 1-PPS-IN and 10-MHz-IN input (connected to the ports marked **IN**) from the timing source and sends 1-PPS-OUT and 10-MHz-OUT to a

client device. If the MX10003 is configured as a timing client device, it receives 1-PPS-IN and 10-MHz-IN (connected to ports marked **IN**) as input from the timing source.

NOTE: Ensure a cable of 3 m or less in length is used for the 10-MHz and 1-PPS connectors.

To connect the DIN cable to the external clocking input port:

1. Connect one end of the DIN cable connectors to the 1-PPS-IN and the 10-MHz-IN ports marked **IN** on the router.

If the MX10003 is a timing primary device, use the 1-PPS-OUT and the 10-MHz-OUT ports marked **OUT** to connect to a client router or device.

2. Connect the other end of the DIN cable to the 10-MHz or 1-PPS source network equipment.

NOTE: Ensure that the 10-MHz or 1-PPS source network equipment contains a low voltage complementary metal oxide semiconductor (LVCMOS) of 50 ohms or is compatible with low-voltage transistor-transistor logic (LVTTTL) (3.3v).

Table 35: Clocking Port on the RCB

Callout (see Figure 29 on page 90)	Label	Description
10	10MHz- IN	1 PPS input port
	1PPS-IN	10 MHz input port
	10MHz-OUT	1 PPS output port
	1PPS-OUT	10 MHz output port

Connecting a Time-of-Day Device to the Router

A time-of-day port labeled **ToD** on the front panel of the RCB enables you to connect external timing devices.

To connect the router to a ToD external timing device:

1. Attach an electrostatic discharge (ESD) grounding strap on your bare wrist, and connect the strap to one of the ESD points on the chassis.
2. Plug one end of the RJ-45 cable into the **ToD** port on the front panel of the RCB.
3. Plug the other end of the RJ-45 cable into the ToD timing device.
4. Verify that the LEDs for the **ToD** port on the router are lit steadily green.
5. Configure the port. See *Configuring Clock Synchronization Interface on MX Series Routers*.

Table 36: Time-of-Day Port on the RCB

Callout (see Figure 29 on page 90)	Label	Description
8	ToD	ToD RJ-45 port.

Connecting a BITS External Clocking Device to the Router

The router has an external building-integrated timing supply (BITS) port labeled **BITS** on the front panel of the RCB.

To connect the router to a BITS external clocking device:

1. Attach an electrostatic discharge (ESD) grounding strap on your bare wrist, and connect the strap to one of the ESD points on the chassis.
2. Plug one end of the RJ-45 cable into the internal clock port on the RCB.
3. Plug the other end of the RJ-45 cable into the BITS external clocking device.
4. Verify that the LEDs for the **BITS** port are lit steadily green.
5. Configure the port. See *Configuring Clock Synchronization Interface on MX Series Routers*.

Table 37: BITS Port on the RCB

Callout (see Figure 29 on page 90)	Label	Description
9	BITS	Building-Integrated Timing Supply (BITS) clock interface port.

RELATED DOCUMENTATION

[MX10003 Routing and Control Board \(RCB\) Description | 32](#)

[Prevention of Electrostatic Discharge Damage | 173](#)

Powering On and Off the MX10003

IN THIS SECTION

- [Powering On an AC-Powered MX10003 Router | 96](#)
- [Powering On a DC-Powered MX10003 Router | 97](#)
- [Powering Off the MX10003 Router | 99](#)

Powering On an AC-Powered MX10003 Router

To power on an AC-powered router:

1. Verify that the power supplies are fully inserted in the chassis.
2. Verify that each AC power cord is securely inserted into its appliance inlet.
3. Verify that an external management device is connected to one of the RCB ports (**CON**).
4. Turn on power to the external management device.
5. Switch on the dedicated customer-site circuit breakers for the power supplies. Follow the instructions for your site.
6. Attach an ESD grounding strap to your bare wrist and connect the strap to one of the ESD points on the chassis.
7. Observe the status LED on each power supply faceplate. If an AC power supply is correctly installed and functioning normally, the status LED above each AC input switch lights steadily green.

If the status LED on the power supply is lit red, the power supply is not functioning normally. Repeat the installation and cabling procedures.

NOTE: After you power off a power supply, wait at least 60 seconds before you turn it back on. Likewise, after you power on a power supply, wait at least 60 seconds before you turn it off.

If the system is completely powered off when you power on the power supply, the Routing Engine (or RCB) boots as the power supply completes its startup sequence. If the Routing Engine finishes booting and you need to power off the system again, first issue the CLI `request system halt` command.

After a power supply is powered on, it can take up to 60 seconds for status indicators—such as the status LEDs on the power supply and the `show chassis` command display—to indicate that the power supply is functioning normally. Ignore error indicators that appear during the first 60 seconds.

8. On the external management device connected to the Routing Engine, monitor the startup process to verify that the system has booted properly.

SEE ALSO

[MX10003 Router Grounding Specifications | 51](#)

`request system halt`

`show chassis power`

[General Safety Guidelines and Warnings | 169](#)

[General Electrical Safety Guidelines and Warnings | 192](#)

[Prevention of Electrostatic Discharge Damage | 173](#)

Powering On a DC-Powered MX10003 Router

To power on a DC-powered router:

1. Verify that an external management device is connected to one of the RCB ports (**CON**).
2. Turn on power to the external management device.
3. Verify that the power supplies are fully inserted in the chassis.
4. Verify that the source power cables are connected to the appropriate terminal: the positive (+) source cable to the return terminal (labeled **RTN**) and the negative (-) source cable to the input terminal (labeled **-48V**).
5. Switch on the dedicated customer-site circuit breakers to provide power to the DC power cables.

6. Check that the status LED on the power supply faceplate is lit steadily blue to verify that power is present.
7. If power is not present:
 - Verify that the fuse is installed correctly, and turn on the breaker at the battery distribution fuse board or fuse bay.
 - Check the voltage with a meter at the terminals of the power supply for correct voltage level and polarity.
8. Attach an ESD grounding strap to your bare wrist, and connect the other end of the strap to an ESD grounding point.
9. Observe the status LED on each power supply faceplate. If a DC power supply is correctly installed and functioning normally, the status LED lights blue steadily.

If the status LED on the power supply is blinking red, the power supply is not functioning normally. Repeat the installation and cabling procedures.

NOTE: After you power off a power supply, wait at least 60 seconds before you turn it back on. Likewise, after you power on a power supply, wait at least 60 seconds before you turn it off.

If the system is completely powered off when you power on the power supply, the Routing Engine (or RCB) boots as the power supply completes its startup sequence. If the Routing Engine finishes booting and you need to power off the system again, first issue the CLI `request system halt` command.

After a power supply is powered on, it can take up to 60 seconds for status indicators—such as the status LEDs on the power supply and the `show chassis` command display—to indicate that the power supply is functioning normally. Ignore error indicators that appear during the first 60 seconds.

10. On the external management device connected to the RCB, monitor the startup process to verify that the system has booted properly.

SEE ALSO

[MX10003 Router Grounding Specifications | 51](#)

`request system halt`

`show chassis power`

[General Safety Guidelines and Warnings | 169](#)

[General Electrical Safety Guidelines and Warnings | 192](#)

[Prevention of Electrostatic Discharge Damage | 173](#)

Powering Off the MX10003 Router

NOTE: After powering off a power supply, wait at least 60 seconds before turning it back on.

To power off the router:

1. On the external management device connected to the RCB, issue the `request system halt` command.

```
user@host> request vmhost halt
```

2. Wait until a message appears on the console confirming that the operating system has halted. For more information about the command, see the [CLI Explorer](#).
3. Attach an ESD grounding strap to your bare wrist, and connect the other end of the strap to an ESD grounding point.
4. Switch off the power supply source.

SEE ALSO

| `request vmhost halt`

Initially Configuring the MX10003 Router

The router is shipped with the Junos operating system (OS) preinstalled and ready to be configured when the router is powered on. Two 16-MB internal NAND Flash memory devices are located on the baseboard for BIOS storage. The USB storage device can be inserted into the slot in the RCB panel faceplate. The system also supports two M.2-based solid-state drive (SSD) slots. These two SSD devices act as the primary boot devices (`sda` and `sdb`). When the router boots, it first attempts to start the Junos OS image on the USB Flash memory drive if it detects one. If a USB flash drive is not inserted into the router, or the attempt otherwise fails, the router next tries the primary boot device, and then tries the secondary boot device.

You configure the router by issuing Junos OS command-line interface (CLI) commands, either on a console device attached to the RCB **CON** port on the front panel.

Gather the following information before configuring the router:

- Name the router will use on the network

- Domain name the router will use
- IP address and prefix length information for the Ethernet interface
- IP address of a default router
- IP address of a DNS server
- Password for the root user

This procedure connects the router to the network but does not enable it to forward traffic. For complete information about enabling the router to forward traffic, including examples, see the Junos OS configuration guides.

To configure the software:

1. Verify that the router is powered on.
2. Log in as the “root” user. There is no password.
3. Start the CLI.

```
root# cli
root@>
```

4. Enter configuration mode.

```
cli> configure
[edit]
root@#
```

5. Configure the name of the router. If the name includes spaces, enclose the name in quotation marks (“ ”).

```
[edit]
root@# set system host-name host-name
```

6. Create a management console user account.

```
[edit]
root@# set system login user user-name authentication plain-text-password
New password: password
Retype new password: password
```

7. Set the user account class to **super-user**.

```
[edit]
root@# set system login user user-name class super-user
```

8. Configure the router's domain name.

```
[edit]
root@# set system domain-name domain-name
```

9. Configure the IP address and prefix length for the router's Ethernet interface.

```
[edit]
root@# set interfaces fxp0 unit 0 family inet address address/prefix-length
```

10. Configure the IP address of a backup router, which is used only while the routing protocol is not running.

```
[edit]
root@# set system backup-router address
```

11. Configure the IP address of a DNS server.

```
[edit]
root@# set system name-server address
```

12. Set the root authentication password by entering either a cleartext password, an encrypted password, or an SSH public key string (DSA or RSA).

```
[edit]
root@# set system root-authentication plain-text-password
New password: password
Retype new password: password
```

or

```
[edit]
root@# set system root-authentication encrypted-password encrypted-password
```

or

```
[edit]
root@# set system root-authentication ssh-dsa public-key
```

or

```
[edit]
root@# set system root-authentication ssh-rsa public-key
```

13. (Optional) Configure the static routes to remote subnets with access to the management port. Access to the management port is limited to the local subnet. To access the management port from a remote subnet, you need to add a static route to that subnet within the routing table. For more information about static routes, see the [Junos OS Administration Library for Routing Devices](#).

```
[edit]
root@# set routing-options static route remote-subnet next-hop destination-IP retain no-
readvertise
```

14. Configure the Telnet service at the [edit system services] hierarchy level.

```
[edit]
root@# set system services telnet
```

15. (Optional) Display the configuration to verify that it is correct.

```
[edit]
root@# show
system {
  host-name host-name;
  domain-name domain-name;
  backup-router address;
  root-authentication {
    authentication-method (password | public-key);
  }
  name-server {
    address;
  }
}
interfaces {
```



```
fxp0 {  
    unit 0 {  
        family inet {  
            address address/prefix-length;  
        }  
    }  
}
```

16. Commit the configuration to activate it on the router.

```
[edit]  
root@# commit
```

17. (Optional) Configure additional properties by adding the necessary configuration statements. Then commit the changes to activate them on the router.

```
[edit]  
root@host# commit
```

18. When you have finished configuring the router, exit configuration mode.

```
[edit]  
root@host# exit  
root@host>
```

RELATED DOCUMENTATION

| [Prevention of Electrostatic Discharge Damage](#) | 173

4

CHAPTER

Maintaining Components

Routine Maintenance Procedures for MX10003 Routers | 105

Maintaining MX10003 Cooling System Components | 106

Maintaining MX10003 Power System Components | 116

Maintaining MX10003 Routing and Control Board | 125

Maintaining MX10003 Interface Modules | 131

Routine Maintenance Procedures for MX10003 Routers

IN THIS SECTION

- [Purpose | 105](#)
- [Action | 105](#)

Purpose

For optimum router performance, perform preventive maintenance procedures.

Action

- Inspect the installation site for moisture, loose wires or cables, and excessive dust. Make sure that airflow is unobstructed around the router and into the air intake vents.
- Check the status-reporting devices on the front panel—system alarms and LEDs.

RELATED DOCUMENTATION

| [Alarm LEDs on the MX10003 Front Panel | 14](#)

Maintaining MX10003 Cooling System Components

IN THIS SECTION

- [Maintaining the MX10003 Air Filter | 106](#)
- [Replacing the MX10003 Air Filter Unit | 107](#)
- [Replacing the MX10003 Air Filter | 109](#)
- [Maintaining the MX10003 Fan Module | 112](#)
- [Replacing an MX10003 Fan Module | 114](#)

Maintaining the MX10003 Air Filter

IN THIS SECTION

- [Purpose | 106](#)
- [Action | 106](#)

Purpose

For optimum cooling, verify the condition of the air filter.

Action

- Regularly inspect the air filter. A dirty air filter restricts airflow in the unit, producing a negative effect on the ventilation of the device. The filter degrades over time. You must replace the filter every 6 months.



CAUTION: Always keep the air filter in place while the device is operating, except during replacement. The fans are very powerful and can pull small bits of wire or other

materials into the device if the air filter isn't in place. These materials can damage device components.

- The shelf life of polyurethane filter varies from two years to five years depending on the storage conditions. Store in a cool, dry, and dark environment. Wrap the media in plastic and store in an environment with relative humidity between 40%- 80% and temperature between 40° F (4° C) to 90° F (32° C). Note that if the material flakes, or becomes brittle when rubbed or deformed, it is no longer usable.

SEE ALSO

[MX10003 Cooling System Description | 16](#)

Replacing the MX10003 Air Filter Unit

IN THIS SECTION

- [Removing the MX10003 Air Filter Unit | 107](#)
- [Installing the MX10003 Air Filter Unit | 108](#)

The air filter unit consists of three parts—the outer filter cover, the air filter, and the inner cage which forms the body, and the air filter. The air filter sits right inside the outer filter cover and the inner cage. The air filter unit is installed into the cable management brackets, and are held tightly by captive screws.

Removing the MX10003 Air Filter Unit

NOTE: Air filter assembly is designed to prevent dust from being drawn into the chassis. This filter assembly must be installed for the product to be NEBS GR 63 compliant.

To remove the air filter unit:

1. Attach an electrostatic discharge (ESD) grounding strap to your bare wrist, and connect the strap to one of the ESD points on the chassis.
2. Loosen the captive screws located on either side of the air filter unit attached at the front of the router.

NOTE: Removing the cables from the cable manager is not necessary to access the air filter.

3. Grasp the air filter unit and gently pull the air filter unit out of the cable management brackets. See Figure 1.

Figure 34: Removing the Air Filter from the Chassis

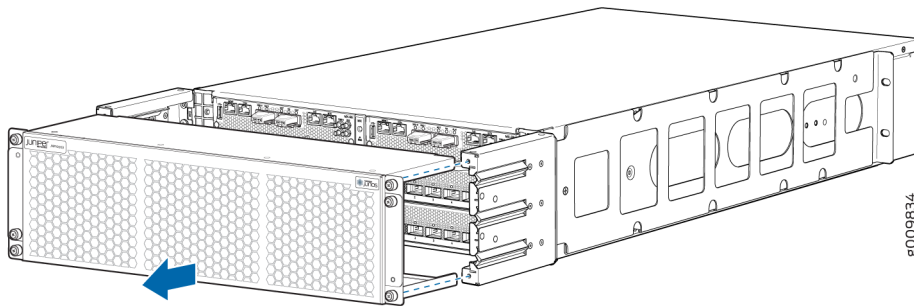

Installing the MX10003 Air Filter Unit

NOTE: The air filter unit is installed on the cable management brackets. Before installing the air filter unit, ensure that the cable management brackets are already installed on the front of the router.

To install the air filter unit:

1. Attach an electrostatic discharge (ESD) grounding strap to your bare wrist, and connect the strap to one of the ESD points on the chassis.
2. Ensure that the air filter unit is right side up.
3. Grasp the air filter unit and slide into the rails on the cable management brackets until it stops (see [Figure 35 on page 109](#)). The air filter unit fits snugly on the cable management brackets.

Figure 35: Installing the Air Filter

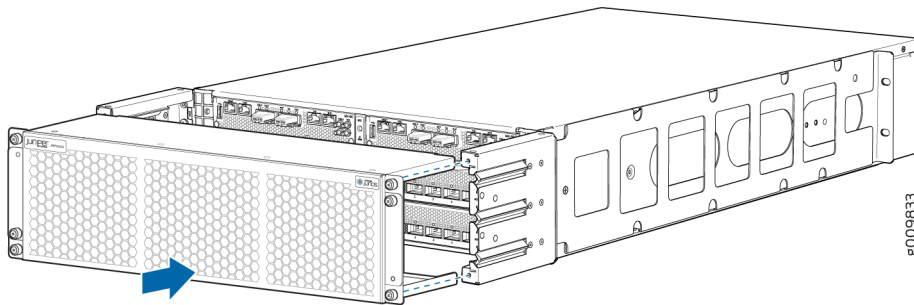

4. Tighten the captive screws to secure the air filter unit.

RELATED DOCUMENTATION

[MX10003 Cooling System Description | 16](#)

[Prevention of Electrostatic Discharge Damage | 173](#)

Replacing the MX10003 Air Filter

IN THIS SECTION

- [Removing the MX10003 Air Filter | 110](#)
- [Installing the MX10003 Air Filter | 111](#)

The air filter unit consists of three parts—the outer and inner metal cage unit which forms the body, and the air filter. The air filter sits right inside the outer and inner cage unit. The air filter unit is installed into the cable management brackets, and are held tightly by captive screws.

Regularly inspect the air filter. A dirty air filter restricts airflow in the unit, producing a negative effect on the ventilation of the chassis.

Removing the MX10003 Air Filter



CAUTION: Do not run the router for more than a few minutes without the air filter in place.



CAUTION: Always keep the air filter unit in place while the router is operating, except during replacement. Because the fans are very powerful, they could pull small bits of wire or other materials into the router through the unfiltered air intake. This could damage the router components.

To remove the air filter:

1. Attach an electrostatic discharge (ESD) grounding strap to your bare wrist, and connect the strap to one of the ESD points on the chassis.
2. Loosen the captive screws located on either side of the air filter unit attached on the front of the router.

NOTE: Removing the cables from the cable manager is not necessary to access the air filter.



CAUTION: Do not run the router for more than 2 minutes without the air filter unit in place.

3. Grasp the head of the loosened screws, and pull to remove the outer air filter cover.
The air filter is located at the center of the air filter unit, and just behind the outer filter cover. See Figure 3.
4. Grasp the air filter, and pull the air filter straight out from the air filter unit.

Figure 36: Removing the Air Filter from the Air Filter Unit

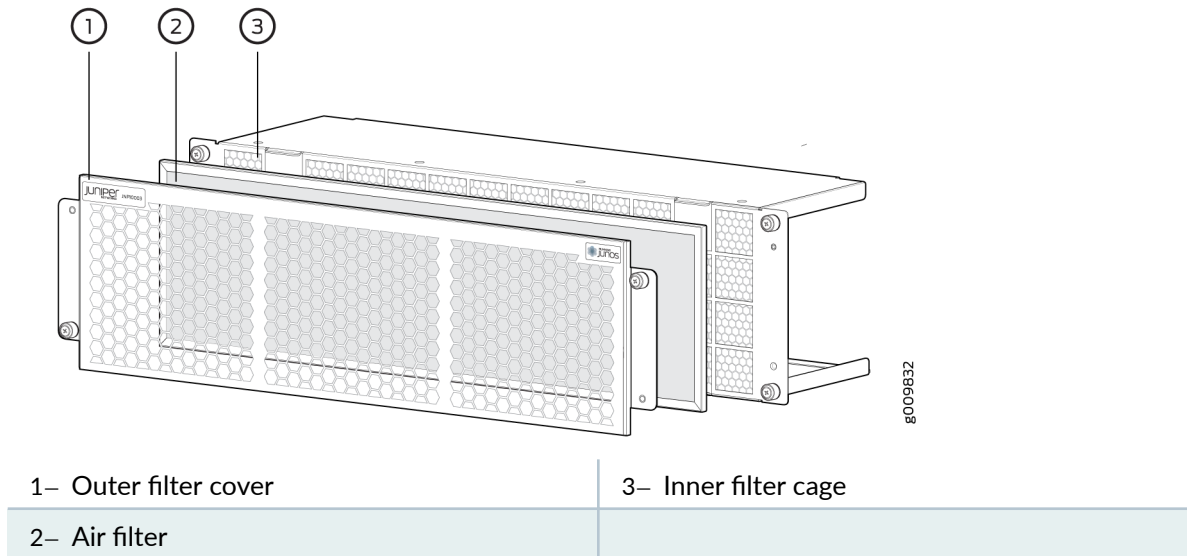

Installing the MX10003 Air Filter

NOTE: The air filter unit is installed on the cable management brackets. Before installing the air filter unit, ensure that the cable management brackets are already installed on the front of the router.

To install the air filter:

1. Attach an electrostatic discharge (ESD) grounding strap to your bare wrist, and connect the strap to one of the ESD points on the chassis.
2. Loosen the captive screws located on either side of the air filter unit attached on the front of the router.

NOTE: Removing the cables from the cable manager is not necessary to access the air filter.



CAUTION: Do not run the router for more than 2 minutes without the air filter unit in place.

3. Grasp the head of the loosened screws, and pull to remove the outer air filter cover.

The air filter is located at the center of the air filter unit, and just behind the outer filter cover. See [Figure 37 on page 112](#).

4. Grasp the air filter, and place the air filter straight onto inner filter cage.

Figure 37: Installing the Air Filter into the Air Filter Unit

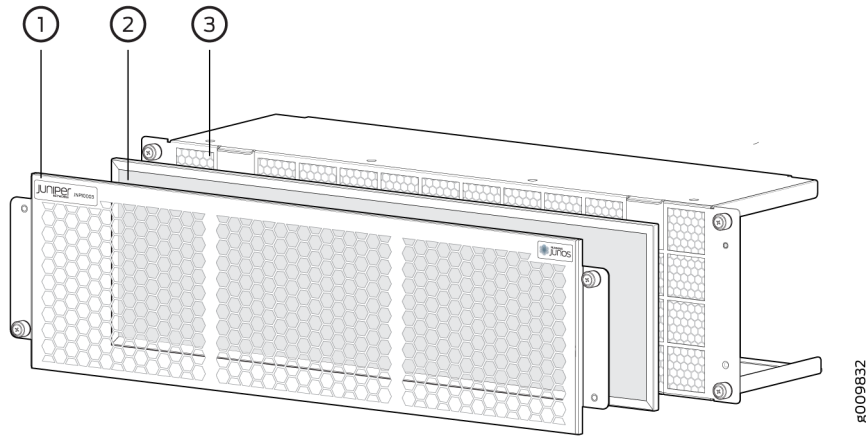

1– Outer filter cover

2– Air filter

3– Inner filter cage

5. Place the outer air filter cover back into its place, and tighten the captive screws to secure the air filter unit.

Maintaining the MX10003 Fan Module

IN THIS SECTION

- Purpose | 112
- Action | 113

Purpose

For optimum cooling, verify the condition of the fans.

Replacing an MX10003 Fan Module

IN THIS SECTION

- [Removing an MX10003 Fan Module | 114](#)
- [Installing an MX10003 Fan Module | 115](#)

Removing an MX10003 Fan Module

NOTE: To prevent overheating, install the replacement fan module immediately after removing the existing fan module.

To remove the fan module (see Figure 5):

1. Attach an ESD grounding strap to your bare wrist and connect the strap to one of the ESD points on the chassis.
2. Loosen the captive screw on the fan module faceplate (use a number-2 Phillips screwdriver).
3. Hold and lift the latch located on the inside of the fan module to release it from the chassis.



WARNING: To prevent injury, keep tools and your fingers away from the fans as you slide the fan module out of the device. The fans might still be spinning.

4. Place one hand under the fan module to support it, and pull the fan module completely out of the chassis.

Figure 38: Removing the Fan Module

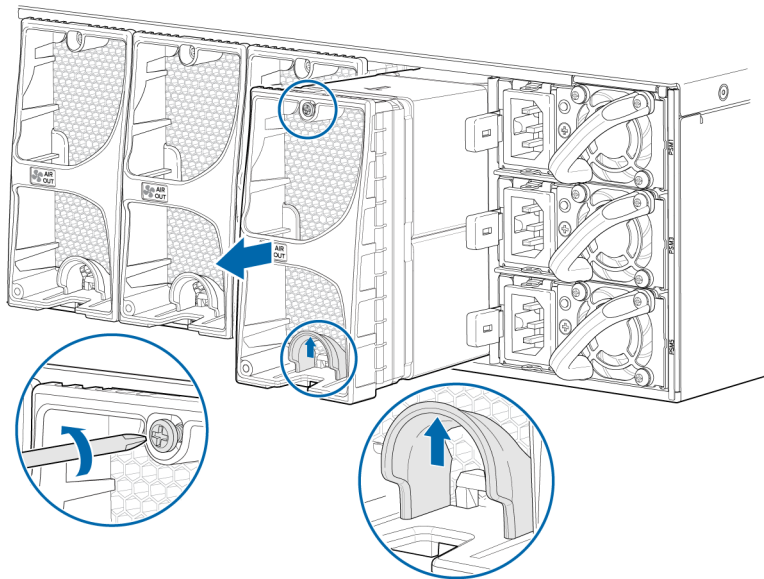

1E96008

Installing an MX10003 Fan Module

To install the fan module (see [Figure 39 on page 116](#)):

1. Attach an ESD grounding strap to your bare wrist and connect the strap to one of the ESD points on the chassis.
2. Grasp the fan module by the handle, and place one hand under the fan module for support.
3. Place the fan module on the respective slot, and carefully push the fan module into the chassis until the socket lock snaps into place and holds it.
4. Using a number-2 Phillips screwdriver, turn the locking screw on the fan module faceplate until it is tight and secured.

Figure 39: Installing the Fan Module

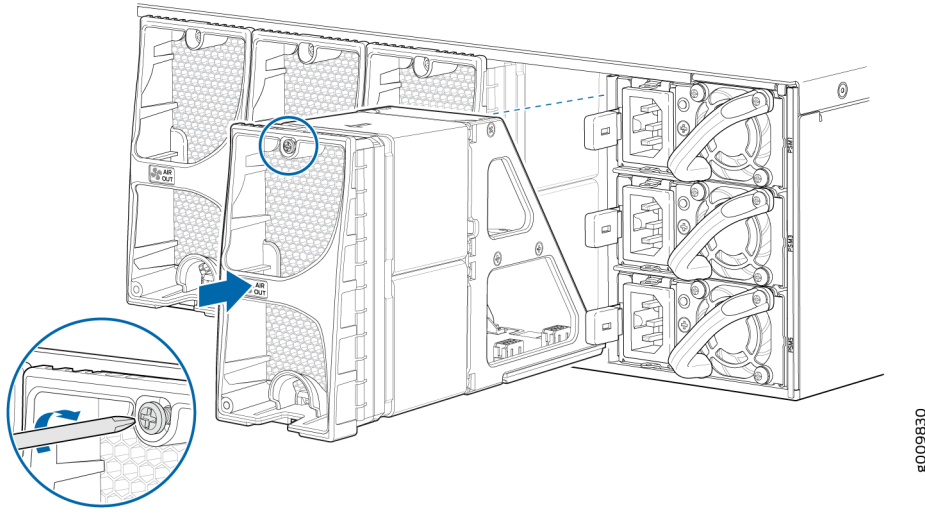

RELATED DOCUMENTATION

[MX10003 Cooling System Description | 16](#)

[Prevention of Electrostatic Discharge Damage | 173](#)

Maintaining MX10003 Power System Components

IN THIS SECTION

- [Maintaining the Power Supplies | 117](#)
- [Replacing an MX10003 AC Power Supply | 118](#)
- [Replacing an MX10003 DC Power Supply | 121](#)

Maintaining the Power Supplies

IN THIS SECTION

- Purpose | 117
- Action | 117

Purpose

For optimum router performance, verify the condition of the power supplies.

Action

On a regular basis check the power supply status:

- To check the power supply status, issue the `show chassis power` CLI command. The output is similar to the following:

```
user@host> show chassis power
PEM 0:
  State:      Online
  Capacity:  1600 W (maximum 1600 W)
  AC input:   OK (1 feed expected, 1 feed connected)
  DC output:  24 W (zone 0, 2 A at 12 V, 1% of capacity)

PEM 1:
  State:      Online
  Capacity:  1600 W (maximum 1600 W)
  AC input:   OK (1 feed expected, 1 feed connected)
  DC output:  300 W (zone 0, 25 A at 12 V, 18% of capacity)
...
```

- Make sure that the power and grounding cables are arranged so that they do not obstruct access to other router components.
- Routinely check the status LEDs on the power supply faceplates and the craft interface to determine if the power supplies are functioning normally.

- Check the red and yellow alarm LEDs on the craft interface. Power supply failure or removal triggers an alarm that causes one or both of the LEDs to light. You can display the associated error messages by issuing the following command:

```
user@host> show chassis alarms
```

- Periodically inspect the site to ensure that the grounding and power cables connected to the router are securely in place and that there is no moisture accumulating near the router.



CAUTION: Do not mix AC and DC power supplies in the same chassis.

SEE ALSO

[MX10003 AC Power System Description | 21](#)

[MX10003 AC Power Supply Module LEDs | 22](#)

Replacing an MX10003 AC Power Supply

IN THIS SECTION

- [Removing an MX10003 AC Power Supply | 118](#)
- [Installing an MX10003 AC Power Supply | 119](#)

Removing an MX10003 AC Power Supply

Before you remove a power supply, be aware of the following:

NOTE: The minimum required number of power supplies must be present in the router at all times.



CAUTION: To maintain proper cooling and prevent thermal shutdown of the operating power supply unit, each power supply slot must contain either a power supply or a blank panel. If you remove a power supply, you must install a replacement power supply or a blank panel shortly after the removal.

NOTE: After powering off a power supply, wait at least 60 seconds before turning it back on.

To remove an AC power supply (see Figure 1):

1. Switch off the dedicated customer-site circuit breaker for the power supply, and remove the power cord from the AC power source. Follow the instructions for your site.
2. Attach an ESD grounding strap to your bare wrist and connect the strap to one of the ESD points on the chassis.
3. Press the release latch on the left side of the AC power supply to disconnect the power supply from the chassis (see Figure 1).
4. Pull the power supply straight out of the chassis.

Figure 40: Removing an AC Power Supply

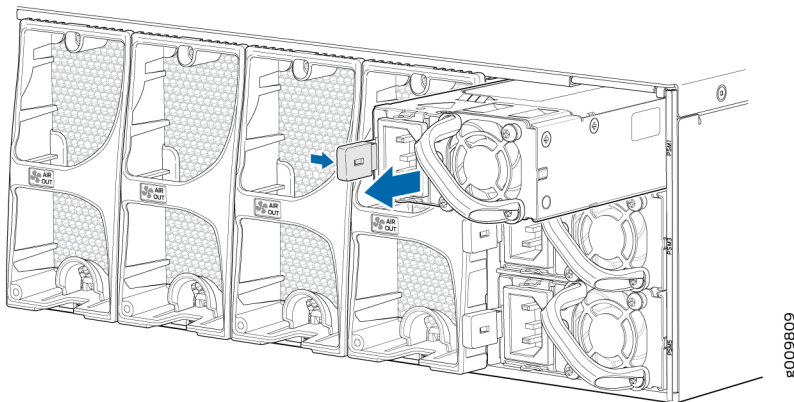

Installing an MX10003 AC Power Supply

To install an AC power supply (see [Figure 41 on page 120](#)):

1. Attach an ESD grounding strap to your bare wrist and connect the strap to one of the ESD points on the chassis.

2. Using both hands, hold and slide the AC power supply straight into the chassis until the power supply is fully seated in the chassis slot. The power supply faceplate must be aligned with any adjacent power supply faceplate or blank installed in the power supply slot.
3. Press the latch located on the left side of the power supply to slide it into the chassis.
4. Attach the power cord to the power supply.
5. Attach the power cord to the AC power source, and switch on the dedicated customer-site circuit breaker. Follow the instructions for your site.
6. Observe the status LED on the power supply faceplate. If the power supply is correctly installed and functioning normally, the status LED lights green steadily.

Figure 41: Installing an AC Power Supply

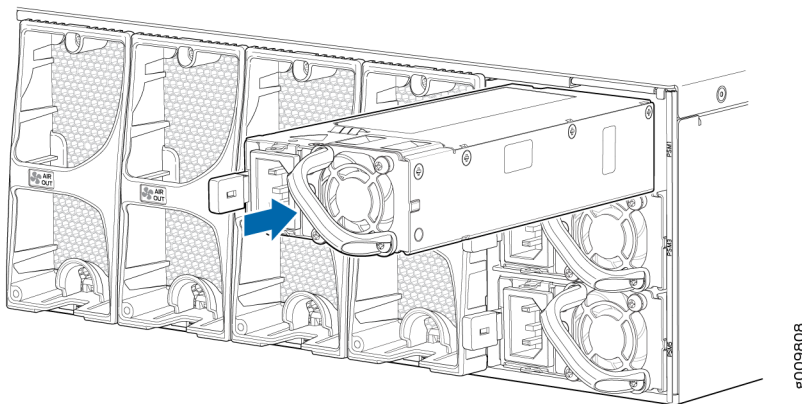

RELATED DOCUMENTATION

[MX10003 AC Power System Description | 21](#)

[MX10003 Router AC Power Specifications | 23](#)

[AC Power Circuit Breaker Requirements for the MX10003 Router | 24](#)

[AC Power Cord Specifications for MX10003 Routers | 24](#)

[Prevention of Electrostatic Discharge Damage | 173](#)

Replacing an MX10003 DC Power Supply

IN THIS SECTION

- [Removing an MX10003 DC Power Supply | 121](#)
- [Installing an MX10003 DC Power Supply | 123](#)

Removing an MX10003 DC Power Supply

Before you remove a power supply, be aware of the following:

NOTE: The minimum required number of power supplies must be present in the router at all times.



WARNING: Before you perform DC power procedures, ensure there is no power to the DC circuit. To ensure that all power is off, locate the circuit breaker on the panel board that services the DC circuit, switch the circuit breaker to the off position, and tape the switch handle of the circuit breaker in the off position.



CAUTION: To maintain proper cooling and prevent thermal shutdown of the operating power supply unit, each power supply slot must contain either a power supply or a blank panel. If you remove a power supply, you must install a replacement power supply or a blank panel shortly after the removal.

NOTE: After powering off a power supply, wait at least 60 seconds before turning it back on.

To remove a DC power supply:

1. Switch off the dedicated customer-site circuit breaker for the power supply being removed. Follow your site's procedures for ESD.
2. Make sure that the voltage across the DC power source cable leads is 0 V and that there is no chance that the cables might become active during the removal process.
3. Verify that the status LED on the power supply is not lit.

4. Attach an ESD grounding strap to your bare wrist and connect the strap to one of the ESD points on the chassis.
5. Using a socket nutdriver, remove the nut from each of the DC power terminals (see Figure 3).
6. Remove the cable lugs from the terminals.
7. Carefully move the power cables out of the way.
8. Press the latch located on the left side of the DC power supply, to release it from the chassis.
9. Pull the power supply straight out of the chassis (see Figure 4).

Figure 42: Disconnecting the DC Power Cables

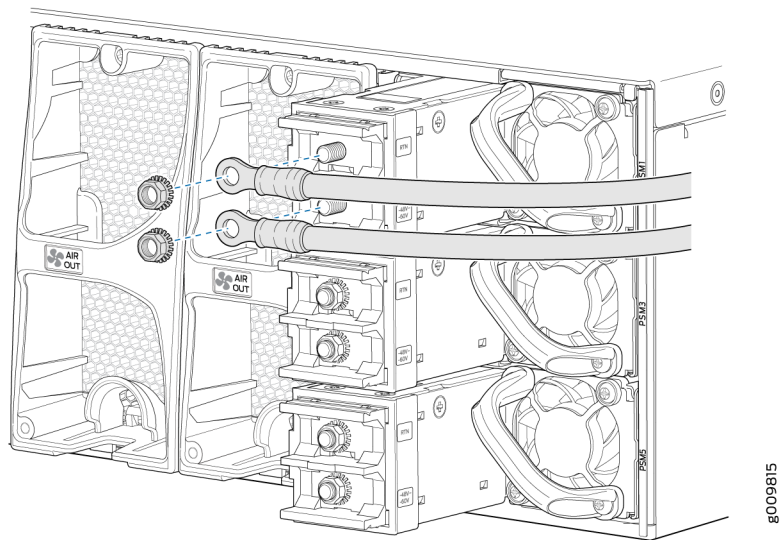
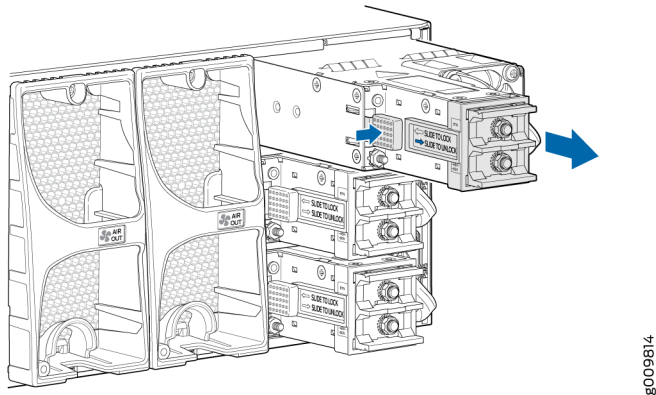

Figure 43: Removing a DC Power Supply



Installing an MX10003 DC Power Supply



WARNING: Before you perform DC power procedures, ensure there is no power to the DC circuit. To ensure that all power is off, locate the circuit breaker on the panel board that services the DC circuit, switch the circuit breaker to the off position, and tape the switch handle of the circuit breaker in the off position.

To install a DC power supply (see [Figure 44 on page 124](#)):

1. Ensure that the voltage across the DC power source cable leads is 0 V and that there is no chance that the cable leads might become active during installation.
2. Attach an ESD grounding strap to your bare wrist and connect the strap to one of the ESD points on the chassis.
3. Using both hands, slide the DC power supply straight into the chassis until the power supply is fully seated in the chassis slot. The power supply faceplate must align with any adjacent power supply faceplate or blank installed in the power supply slot.
4. Remove the nuts from the terminals.
5. Secure each power cable lug to the terminal with the nut (see [Figure 45 on page 124](#)). Apply between 5 lb-in. (0.6 Nm) and 6 lb-in. (0.7 Nm) of torque to the nut. Do not overtighten the nut (use a socket nut driver).
 - a. Secure the positive (+) DC source power cable lug to the **RTN** (return) terminal.
 - b. Secure the negative (-) DC source power cable lug to the **-48V** (input) terminal.



CAUTION: Ensure that each power cable lug seats flush against the surface of the terminal block as you are tightening the screws. Ensure that each screw is properly threaded into the terminal. Applying installation torque to the screw when improperly threaded can result in damage to the terminal.



CAUTION: You must ensure that power connections maintain the proper polarity. The power source cables might be labeled **(+)** and **(-)** to indicate their polarity. There is no standard color coding for DC power cables. The color coding used by the external DC power source at your site determines the color coding for the leads on the power cables that attach to the terminal studs on each power supply.

6. Verify that the power cabling is correct, that the cables are not touching or blocking access to router components, and that they do not drape where people could trip on them.

- Attach the power cable to the DC power source, and switch on the dedicated customer-site circuit breaker. Follow the instructions for your site.

NOTE: If more than one power supply is being installed, turn on all power supplies at the same time.

- Observe the status LED on the power supply faceplate. If the power supply is correctly installed and functioning normally, the status LED lights green steadily.

Figure 44: Installing a DC Power Supply

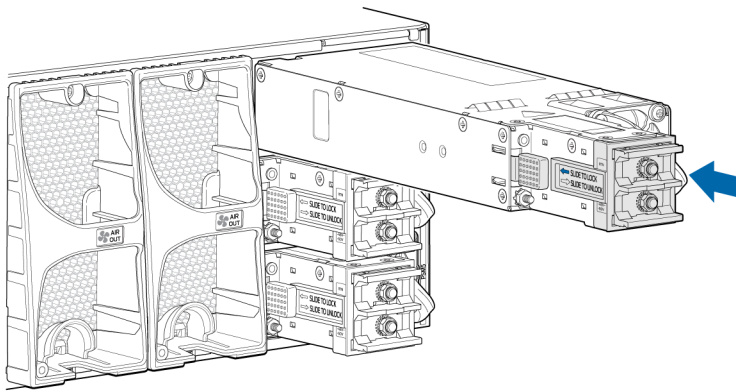

8009813

Figure 45: Connecting the DC Power Cables

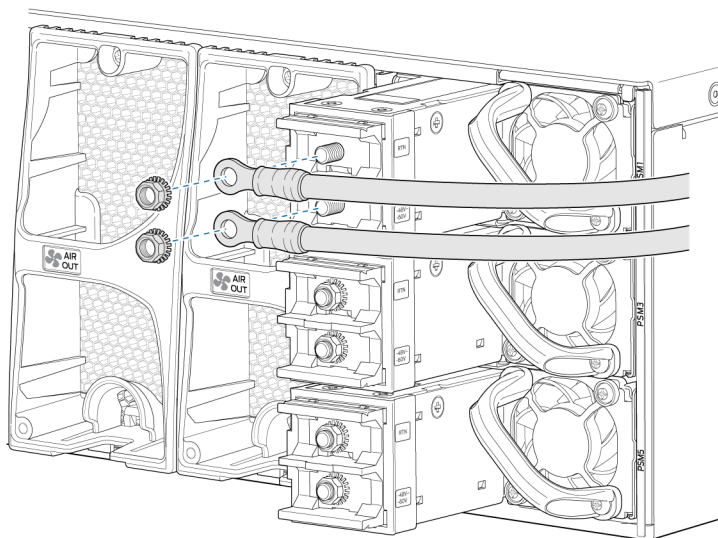

8009815

RELATED DOCUMENTATION

- [MX10003 AC Power System Description | 21](#)
- [MX10003 Router DC Power Specifications | 29](#)
- [DC Power Circuit Breaker Requirements for the MX10003 Router | 29](#)
- [DC Power Source Cabling for MX10003 Router | 30](#)
- [DC Power Cable Specifications for MX10003 Router | 31](#)
- [Prevention of Electrostatic Discharge Damage | 173](#)

Maintaining MX10003 Routing and Control Board

IN THIS SECTION

- [Maintaining the Routing and Control Board \(RCB\) | 125](#)
- [Replacing an MX10003 RCB | 127](#)

Maintaining the Routing and Control Board (RCB)

IN THIS SECTION

- [Purpose | 125](#)
- [Action | 125](#)

Purpose

For optimum router performance, verify the condition of the RCB on regular basis.

Action

On a regular basis:

- Check the LEDs on the front panel to view information about the status of the RCB.
- To check the status of the Routing Engine on the RCB, issue the `show chassis routing-engine` command. The output is similar to the following:

```
user@host> show chassis routing-engine
Routing Engine status:
Slot 0:
  Current state           Master
  Election priority      Master (default)
  Temperature            44 degrees C / 111 degrees F
  CPU temperature        41 degrees C / 105 degrees F
  DRAM                   49110 MB (49152 MB installed)
  Memory utilization     4 percent
  5 sec CPU utilization:
    User                 0 percent
    Background          0 percent
    Kernel               1 percent
    Interrupt           0 percent
    Idle                 99 percent
  1 min CPU utilization:
    User                 0 percent
    Background          0 percent
    Kernel               1 percent
    Interrupt           0 percent
    Idle                 99 percent
  5 min CPU utilization:
    User                 0 percent
    Background          0 percent
    Kernel               1 percent
    Interrupt           0 percent
    Idle                 99 percent
  15 min CPU utilization:
    User                 0 percent
    Background          0 percent
    Kernel               1 percent
    Interrupt           0 percent
    Idle                 99 percent
  Start time            2017-08-19 23:31:33 PDT
  Uptime                7 hours, 33 minutes, 29 seconds
  Last reboot reason    0x2000:hypervisor reboot
  Load averages:       1 minute  5 minute  15 minute
```

	0.09	0.20	0.18
Routing Engine status:			
Slot 1:			
Current state	Present		

SEE ALSO

[MX10003 Routing and Control Board \(RCB\) Description | 32](#)

[MX10003 RCB LEDs | 37](#)

show chassis routing-engine

Replacing an MX10003 RCB

IN THIS SECTION

- [Removing an MX10003 RCB | 127](#)
- [Installing an MX10003 RCB | 128](#)

Removing an MX10003 RCB

The MX10003 host subsystem consists of two Routing and Control Boards (RCBs). The RCB is an integrated board and a single FRU that provides Routing Engine and Control Board functionality and supports virtualization.

To remove an RCB (see Figure 1):

NOTE: You can remove the RCB as a unit.



CAUTION: Before removing an RCB, ensure that you know how to operate the ejector handles properly to avoid damage to the equipment.



CAUTION: Before you replace an RCB, you must take the host subsystem offline. If there is only one host subsystem, taking the host subsystem offline shuts down the router.

1. Take the host subsystem offline.
2. Place an electrostatic bag or antistatic mat on a flat, stable surface.
3. Attach an electrostatic discharge (ESD) grounding strap to your bare wrist, and connect the strap to one of the ESD points on the chassis.
4. Open the ejector handle outward to unseat the RCB.
5. Grasp the ejector handle, and slide the RCB about halfway out of the chassis.
6. Place one hand underneath the RCB to support it, and slide it completely out of the chassis.
7. Place the RCB on the antistatic mat or into an antistatic bag.
8. If you are not replacing the RCB immediately, install a blank panel over the empty slot.

Figure 46: Removing a RCB

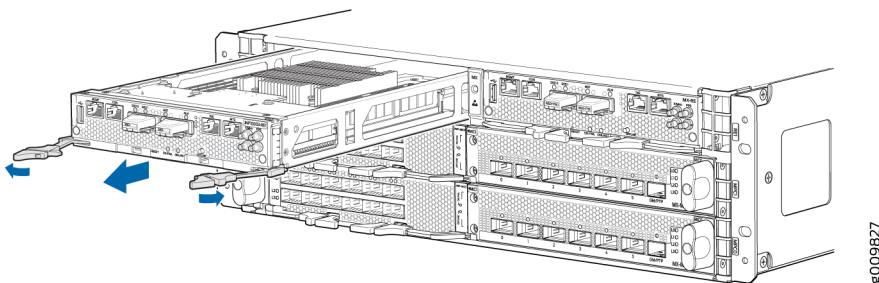

8009827

Installing an MX10003 RCB

To install an MX10003 RCB (see [Figure 47 on page 130](#)):

1. Attach an electrostatic discharge (ESD) grounding strap to your bare wrist, and connect the strap to one of the ESD points on the chassis.
2. Remove the RCB from the electrostatic bag.
3. Carefully align the sides of the RCB with the guides inside the chassis.
4. Slide the RCB into the chassis until you feel resistance, carefully ensuring that it is correctly aligned.
5. Grasp the ejector handle, and gently close it inward simultaneously until the RCB is fully seated.
6. Check the LEDs on the RCB faceplate to verify that it is functioning normally.
 - The green **OK/FAIL** LED should light steadily a few minutes after the RCB is installed.

- If the **OK/FAIL** LED is red, remove and install the RCB again. If the **OK/FAIL** LED still lights steadily, the RCB is not functioning properly. Contact your customer support representative. See *Contact Customer Support*.

7. Check the status of the RCB by using the `show chassis routing-engine` command:

```

user@host> show chassis routing-engine
Routing Engine status:
Slot 0:
  Current state           Master
  Election priority       Master (default)
  Temperature              41 degrees C / 105 degrees F
  CPU temperature          43 degrees C / 109 degrees F
  DRAM                     49112 MB (49152 MB installed)
  Memory utilization       6 percent
  5 sec CPU utilization:
    User                   1 percent
    Background              0 percent
    Kernel                  0 percent
    Interrupt               0 percent
    Idle                    99 percent
  1 min CPU utilization:
    User                   2 percent
    Background              0 percent
    Kernel                  1 percent
    Interrupt               0 percent
    Idle                    97 percent
  5 min CPU utilization:
    User                   1 percent
    Background              0 percent
    Kernel                  1 percent
    Interrupt               0 percent
    Idle                    98 percent
  15 min CPU utilization:
    User                   1 percent
    Background              0 percent
    Kernel                  1 percent
    Interrupt               0 percent
    Idle                    97 percent
  Model                    RE-S-2X00x6
  Start time                2017-11-06 22:55:43 PST
  Uptime                   1 hour, 7 minutes, 19 seconds
  Last reboot reason        0x2000:hypervisor reboot

```

```

Load averages:          1 minute   5 minute  15 minute
                        0.54       0.45     0.42

Routing Engine status:
Slot 1:
  Current state         Backup
  Election priority     Backup (default)
  Temperature           43 degrees C / 109 degrees F
  CPU temperature       42 degrees C / 107 degrees F
  DRAM                  49109 MB (49152 MB installed)
  Memory utilization    4 percent
  5 sec CPU utilization:
    User                0 percent
    Background          0 percent
    Kernel              0 percent
    Interrupt           0 percent
    Idle                100 percent
  Model                 RE-S-2X00x6
  Start time            2017-11-04 02:37:23 PDT
  Uptime                2 days, 22 hours, 25 minutes, 41 seconds
  Last reboot reason    0x1:power cycle/failure
  Load averages:       1 minute   5 minute  15 minute
                        0.16       0.14     0.09

```

Figure 47: Installing an MX10003 RCB

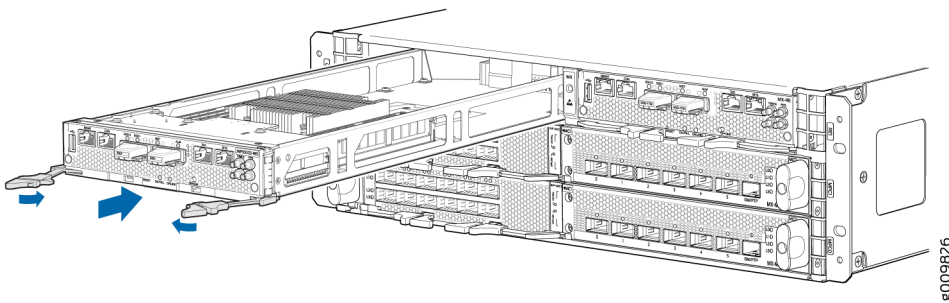

RELATED DOCUMENTATION

[MX10003 Routing and Control Board \(RCB\) Description | 32](#)

[MX10003 RCB LEDs | 37](#)

Maintaining MX10003 Interface Modules

IN THIS SECTION

- Maintaining MICs | 131
- Replacing an MX10003 MIC | 132
- Maintaining MPCs | 136
- Replacing an MX10003 MPC | 138
- Maintaining Cables That Connect to MPCs or MICs | 143
- Replacing a Cable on an MX10003 MPC or MIC | 144
- Replace an SFP, SFP+, or QSFP+ Transceiver | 147
- Replace a QSFP28 Transceiver | 151

Maintaining MICs

IN THIS SECTION

- Purpose | 131
- Action | 131

Purpose

For optimum router performance, verify the condition of the MICs.

Action

On a regular basis:

- Check the LEDs on MIC faceplates. The meaning of the LED states differs for various MICs. For more information, see the [MX Series Interface Module Reference](#). If the MPC that houses the MIC detects a MIC failure, the MPC generates an alarm message to be sent to the Routing Engine.

- Issue the `show chassis fpc pic-status` CLI command. The MIC slots in an MPC are numbered **PIC 0** and **PIC 1**, right to left:

```
user@host> show chassis fpc pic-status
Slot 0  Online      LC2103
  PIC 0  Online      6xQSFP
  PIC 1  Online      MIC1
Slot 1  Online      LC2103
  PIC 0  Online      6xQSFP
  PIC 1  Online      MIC1
```

For further description of the output from the command, see the [CLI Explorer](#).

Replacing an MX10003 MIC

IN THIS SECTION

- [Removing an MX10003 MIC | 132](#)
- [Installing an MX10003 MIC | 134](#)

Removing an MX10003 MIC

MICs are hot-insertable and hot-removable. When you remove a MIC, the router continues to function, although the MIC interfaces being removed no longer function.

NOTE: On the MX10003 MPC (Multi-Rate), only the MIC in slot **1** is removable. The MIC in slot **0** is fixed to the MPC and cannot be removed.

The MICs are located in the MPCs installed at the front of the router. A typical MIC weighs around 3 lb (1.36 kg).

To remove a MIC (see Figure 2):

1. Place an electrostatic bag or antistatic mat on a flat, stable surface to receive the MIC. If the MIC connects to fiber-optic cable, have ready a rubber safety cap for each transceiver and cable.

2. Attach an electrostatic discharge (ESD) grounding strap to your bare wrist, and connect the strap to one of the ESD points on the chassis.
3. Use one of the following methods to take the MIC offline:
 - Press its **OFFLINE** button. Use a narrow-ended tool that fits inside the opening that leads to the button. Press and hold the button (for about 5 seconds) until the MIC's **OK/FAIL** LED goes off. Figure 1 shows the location of the **OFFLINE** button on the MIC.

Figure 48: JNP-MIC

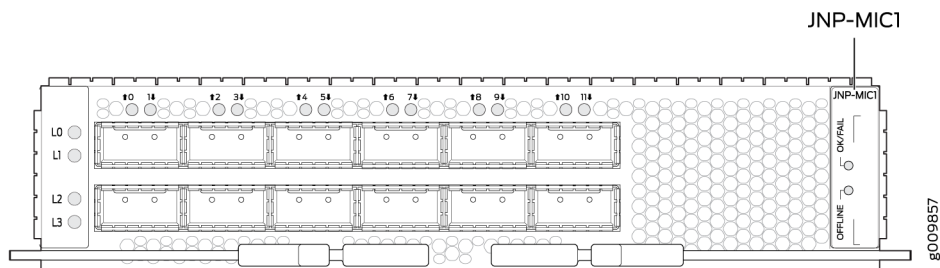

- Issue the following CLI command:

```
user@host> request chassis pic fpc-slot fpc-slot pic-slot pic-slot offline
```

For more information about the command, see the [Junos OS System Basics and Services Command Reference](#).

4. Label the cables connected to the MIC so that you can later reconnect each cable to the correct MIC.
5. Disconnect the cables from the MIC. If the MIC uses fiber-optic cable, immediately cover each transceiver and the end of each cable with a rubber safety cap.



LASER WARNING: Do not look directly into a fiber-optic transceiver or into the ends of fiber-optic cables. Fiber-optic transceivers and fiber-optic cable connected to a transceiver emit laser light that can damage your eyes.



CAUTION: Do not leave a fiber-optic transceiver uncovered except when inserting or removing cable. The safety cap keeps the port clean and prevents accidental exposure to laser light.

6. Arrange the cable to prevent it from dislodging or developing stress points. Secure the cable so that it does not support its own weight as it hangs to the floor. Place excess cable out of the way in a neatly coiled loop.



CAUTION: Avoid bending fiber-optic cable beyond its minimum bend radius. An arc smaller than a few inches in diameter can damage the cable and cause problems that are difficult to diagnose.

7. Pull both the ejector levers of the MIC you are removing away from the MPC faceplate. Doing this disconnects the MIC from the MPC.
8. Grasp the handles on the MIC faceplate, and slide the MIC out of the MPC card carrier. Place it in the electrostatic bag or on the antistatic mat.
9. If you are not reinstalling a MIC into the emptied MIC slot within a short time, install a blank MIC panel over the slot to maintain proper airflow in the MPC card cage.

Figure 49: Removing a MIC

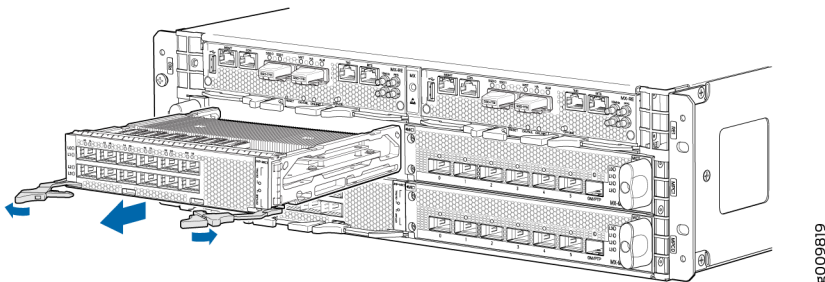

6186008

Installing an MX10003 MIC

To install a MIC (see [Figure 50 on page 136](#)):

1. Attach an electrostatic discharge (ESD) grounding strap to your bare wrist, and connect the strap to one of the ESD points on the chassis.
2. If the MIC uses fiber-optic cable, verify that a rubber safety cap is over each transceiver on the faceplate. Install a cap if necessary.
3. Align the rear of the MIC with the guides located at the corners of the MIC slot.
4. Grasp and press both the MIC ejector handles inward, and slide the MIC until the ejectors latch into the MPC.



CAUTION: Slide the MIC straight into the slot to avoid damaging the components on the MIC.

5. Verify that the ejector lever is engaged properly by pushing it toward the MIC faceplate.
6. If the MIC uses fiber-optic cable, remove the rubber safety cap from each transceiver and the end of each cable.



LASER WARNING: Do not look directly into a fiber-optic transceiver or into the ends of fiber-optic cables. Fiber-optic transceivers and fiber-optic cable connected to a transceiver emit laser light that can damage your eyes.



CAUTION: Do not leave a fiber-optic transceiver uncovered except when inserting or removing cable. The safety cap keeps the port clean and prevents accidental exposure to laser light.

7. Insert the appropriate cables into the cable connectors on the MIC.
8. Arrange each cable to prevent the cable from dislodging or developing stress points. Secure the cable so that it does not support its own weight as it hangs to the floor. Place excess cable out of the way in a neatly coiled loop.



CAUTION: Do not let fiber-optic cable hang free from the connector. Do not allow fastened loops of cable to dangle, which stresses the cable at the fastening point.



CAUTION: Avoid bending fiber-optic cable beyond its minimum bend radius. An arc smaller than a few inches in diameter can damage the cable and cause problems that are difficult to diagnose.

9. To bring the MIC online:
 - Issue the following CLI command:

```
user@host> request chassis pic fpc-slot fpc-slot pic-slot pic-slot online
```

For more information about the command, see the [Junos OS System Basics and Services Command Reference](#).

- For bringing MIC1 online using the button:

Press the **OFFLINE** button on MIC1 until the MIC **OK/FAIL** LED lights green. Figure 1 shows the location of the offline button on the MIC. Use a narrow-ended tool that fits inside the opening that leads to the button.

NOTE: There is no **OFFLINE** button for the built-in MIC (MIC0). You can use the **OFFLINE** button on MIC1 to make the MIC1 offline and online.

The normal functioning **OK/FAIL** LED confirms that the MIC is online. You can also verify correct MIC functioning by issuing the `show chassis fpc pic-status` command.

Figure 50: Installing a MIC

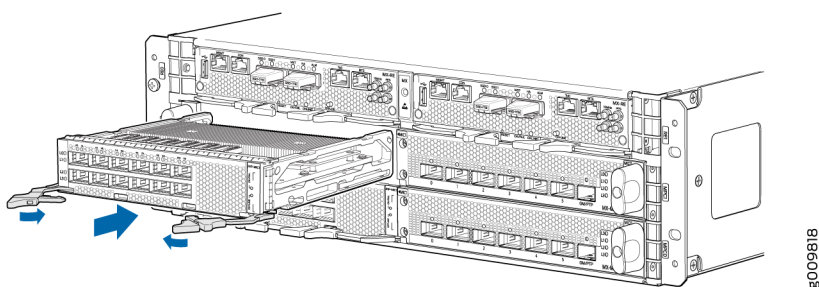

RELATED DOCUMENTATION

[Routine Maintenance Procedures for MX10003 Routers](#) | 105

[Prevention of Electrostatic Discharge Damage](#) | 173

Maintaining MPCs

IN THIS SECTION

● Purpose | 137

● Action | 137

Purpose

The router can have up to two MPCs mounted horizontally in the card cage at the front of the chassis. For optimum router performance, verify the condition of the MPCs.

Action

On a regular basis:

- Check the **OK/FAIL** LED on the MPC. If the MPC detects a failure, the MPC sends an alarm message to the Routing Engine.
- Issue the `show chassis fpc` CLI command to check the status of installed MPCs. As shown in the sample output, the value **Online** in the column labeled **State** indicates that the MPC is functioning normally:

```

user@host> show chassis fpc
          Temp CPU Utilization (%) CPU Utilization (%) Memory Utilization
          (%)
Slot State      (C) Total Interrupt      1min  5min  15min  DRAM (MB) Heap
Buffer
  0 Online       57   24         0     21   23   23   3136   12   11
  1 Online       58   20         0     21   23   23   3136   12   11

```

For more detailed output, add the **detail** option. The following example does not specify a slot number, which is optional:

```

user@host> show chassis fpc detail
Slot 0 information:
  State                               Online
  Total CPU DRAM                       3136 MB
  Total RLDRAM                          771 MB
  Total DDR DRAM                        18432 MB
  Temperature                           57 degrees C / 134 degrees F
  Start time                            2017-08-20 01:40:14 PDT
  Uptime                                 5 hours, 14 minutes, 5 seconds
  Max MPC base power consumption        910 Watts
  Max MIC1 power consumption            0 Watts
  Max MPC total power consumption        910 Watts
Slot 1 information:
  State                               Online
  Total CPU DRAM                       3136 MB
  Total RLDRAM                          771 MB

```

```

Total DDR DRAM          18432 MB
Temperature             58 degrees C / 136 degrees F
Start time              2017-08-20 01:40:14 PDT
Uptime                 5 hours, 14 minutes, 5 seconds
Max MPC base power consumption  910 Watts
Max MIC1 power consumption    0 Watts
Max MPC total power consumption 910 Watts

```

- Issue the `show chassis fpc pic-status` CLI command. The MPC slots are numbered **0** and **1**, bottom to top:

```

user@host> show chassis fpc pic-status
Slot 0  Online      LC2103
  PIC 0  Online      6xQSFP
  PIC 1  Online      MIC1
Slot 1  Online      LC2103
  PIC 0  Online      6xQSFP
  PIC 1  Online      MIC1

```

For further description of the output from the command, see the [CLI Explorer](#).

Replacing an MX10003 MPC

IN THIS SECTION

- [Removing an MX10003 MPC | 138](#)
- [Installing an MX10003 MPC | 140](#)

Removing an MX10003 MPC

When you remove an MPC, the router continues to function, although the MIC interfaces installed on the MPC being removed no longer function.

An MPC installs horizontally in the front of the router. The MPCs are hot-insertable and hot-removable. A fully configured MPC can weigh up to 33 lb (14.96 kg). Be prepared to accept its full weight.

To remove an MPC (see Figure 4):

1. Have ready a replacement MPC blank panel and an antistatic mat for the MPC. Also have ready rubber safety caps for each MIC using an optical interface on the MPC that you are removing.
2. Attach an ESD grounding strap to your bare wrist and connect the strap to one of the ESD points on the chassis.
3. Label the cables connected to each MIC on the MPC so that you can later reconnect the cables to the correct MICs.
4. Use one of the following methods to take the MPC offline:
 - Press and hold the **OFFLINE** button on the MPC. The green **OK/FAIL** LED next to the button begins to blink. Hold the button down until the LED goes off. Use a narrow-ended tool that fits inside the opening that leads to the button.
 - Issue the following CLI command:

```
user@host>request chassis fpc slot slot-number offline
```

For more information about the command, see the [CLI Explorer](#).

5. Disconnect the cables from the MICs installed in the MPC.



LASER WARNING: Do not look directly into a fiber-optic transceiver or into the ends of fiber-optic cables. Fiber-optic transceivers and fiber-optic cables connected to a transceiver emit laser light that can damage your eyes.



CAUTION: Do not leave a fiber-optic transceiver uncovered, except when inserting or removing a cable. The safety cap keeps the port clean and protects your eyes from accidental exposure to laser light.



CAUTION: Do not bend a fiber-optic cable beyond its minimum bend radius. An arc smaller than a few inches in diameter can damage the cable and cause problems that are difficult to diagnose.

6. If a MIC uses fiber-optic cable, immediately cover each transceiver and the end of each cable with a rubber safety cap.
7. Arrange the disconnected cables in the cable management brackets to prevent the cables from developing stress points.
8. Simultaneously turn both the ejector handles counterclockwise to unseat the MPC.
9. Grasp the handles, and slide the MPC straight out of the card cage halfway.

- Place one hand around the front of the MPC and the other hand under it to support it. Slide the MPC completely out of the chassis, and place it on the antistatic mat or in the electrostatic bag.



CAUTION: The weight of the MPC is concentrated in the back end. Be prepared to accept the full weight as you slide the MPC out of the chassis.

When the MPC is out of the chassis, do not hold it by the ejector handles, bus bars, or edge connectors. They cannot support its weight.

Do not stack MPCs on top of one another after removal. Place each one individually in an electrostatic bag or on its own antistatic mat on a flat, stable surface.

- If necessary, remove the installed MIC from the MPC.
- After you remove each MIC, immediately place it on an antistatic mat or in an electrostatic bag.
- If you are not reinstalling an MPC into the emptied line card slots within a short time, install a blank MPC panel over each slot to maintain proper airflow in the card cage.



CAUTION: After removing an MPC from the chassis, wait at least 30 seconds before reinserting it or inserting an MPC into a different slot.

Figure 51: Removing an MPC

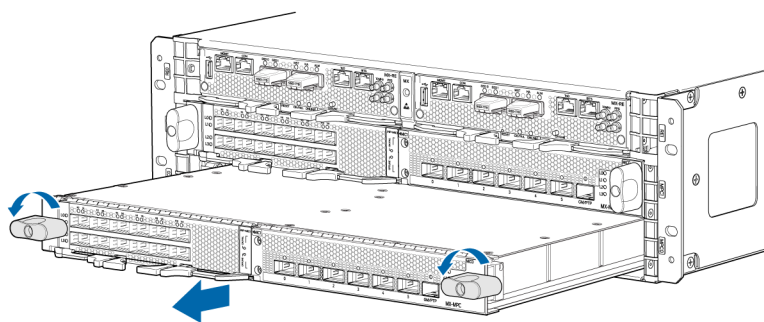

8009823

Installing an MX10003 MPC

An MPC installs horizontally at the front of the router. The MPCs are hot-insertable and hot-removable. A fully configured MPC can weigh up to 18.35 lb (8.3 kg). Be prepared to accept its full weight.

To install an MPC (see [Figure 52 on page 142](#)):

- Attach an ESD grounding strap to your bare wrist and connect the strap to one of the ESD points on the chassis.

2. Place the MPC on an antistatic mat.
3. Take the MIC to be installed in the replacement MPC out of its electrostatic bag.
4. Verify that each fiber-optic MIC has a rubber safety cap covering the MIC transceiver. If it does not, cover the transceiver with a safety cap.
5. Install the MIC into the appropriate slot on the MPC.
6. Locate the slot in the card cage in which you plan to install the MPC.
7. Orient the MPC so that the faceplate faces you.
8. Lift the MPC into place, and carefully align the sides of the MPC with the guides inside the card cage.



CAUTION: When the MPC is out of the chassis, do not hold it by the ejector handles, bus bars, or edge connectors. They cannot support its weight.

9. Slide the MPC all the way into the card cage until you feel resistance.
10. Grasp both ejector handles, and rotate them clockwise simultaneously until the MPC is fully seated.
11. If any of the MICs on the MPC connect to fiber-optic cable, remove the rubber safety cap from each transceiver and cable.



LASER WARNING: Do not look directly into a fiber-optic transceiver or into the ends of fiber-optic cables. Fiber-optic transceivers and fiber-optic cables connected to a transceiver emit laser light that can damage your eyes.

12. Insert the appropriate cable into the cable connector ports on each MIC on the MPC. Secure the cables so that they are not supporting their own weight. Place excess cable out of the way in a neatly coiled loop, using the cable management system. Placing fasteners on a loop helps to maintain its shape.



CAUTION: Do not let fiber-optic cables hang free from the connector. Do not allow the fastened loops of a cable to dangle, which stresses the cable at the fastening point.



CAUTION: Do not bend a fiber-optic cable beyond its minimum bend radius. An arc smaller than a few inches in diameter can damage the cable and cause problems that are difficult to diagnose.

13. To bring the MPC online:

- Issue the following CLI command:

```
user@host>request chassis fpc slot slot-number online
```

For more information about the command, see the [CLI Explorer](#).



CAUTION: After the **OK/FAIL** LED lights steadily, wait at least 30 seconds before removing the MPC again, removing an MPC from a different slot, or inserting an MPC in a different slot.

You can also verify correct MPC and MIC functioning by issuing the `show chassis fpc` and `show chassis fpc pic-status` commands.

Figure 52: Installing an MPC

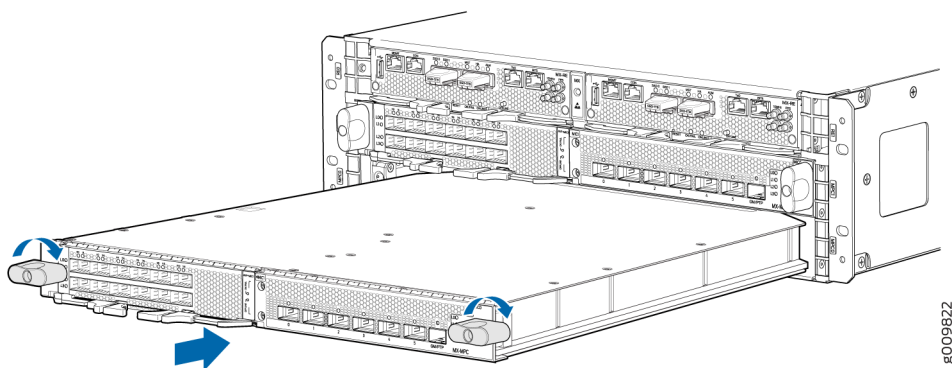

RELATED DOCUMENTATION

[Replacing a Cable on an MX10003 MPC or MIC | 144](#)

[Routine Maintenance Procedures for MX10003 Routers | 105](#)

[Prevention of Electrostatic Discharge Damage | 173](#)

Maintaining Cables That Connect to MPCs or MICs

IN THIS SECTION

- Purpose | 143
- Action | 143

Purpose

For optimum router performance, verify the condition of the cables that connect to the MPCs or MICs.

Action

On a regular basis:

- Use the cable management brackets to support cables and prevent cables from dislodging or developing stress points.
- Place excess cable out of the way in the cable management brackets. Do not allow fastened loops of cable to dangle from the connector or cable management brackets, because this stresses the cable at the fastening point. Putting fasteners on the loops helps to maintain their shape.
- Keep the cable connections clean and free of dust and other particles, which can cause drops in the received power level. Always inspect cables and clean them if necessary before connecting an interface.
- Label both ends of the cables to identify them.

The following guidelines apply specifically to fiber-optic cables:

- When you unplug a fiber-optic cable, always place a rubber safety plug over the transceiver on the faceplate and on the end of the cable.
- Anchor fiber-optic cables to avoid stress on the connectors. Be sure to secure fiber-optic cables so that they do not support their own weight as they hang to the floor. Never let fiber-optic cable hang free from the connector.
- Avoid bending fiber-optic cable beyond its bend radius. An arc smaller than a few inches can damage the cable and cause problems that are difficult to diagnose.

- Frequent plugging and unplugging of fiber-optic cable into and out of optical instruments can cause damage to the instruments that is expensive to repair. Instead, attach a short fiber extension to the optical equipment. Any wear and tear due to frequent plugging and unplugging is then absorbed by the short fiber extension, which is easy and inexpensive to replace.
- Keep fiber-optic cable connections clean. Small microdeposits of oil and dust in the canal of the transceiver or cable connector could cause loss of light, reducing signal power and possibly causing intermittent problems with the optical connection.

To clean the transceivers, use an appropriate fiber-cleaning device, such as RIFOCS Fiber Optic Adaptor Cleaning Wands (part number 946). Follow the directions for the cleaning kit you use.

After you clean an optical transceiver, make sure that the connector tip of the fiber-optic cable is clean. Use only an approved alcohol-free fiber-optic cable cleaning kit, such as the Opptex Cletop-S Fiber Cleaner. Follow the directions for the cleaning kit you use.

Replacing a Cable on an MX10003 MPC or MIC

IN THIS SECTION

- [Removing a Cable on an MPC or MIC | 144](#)
- [Installing a Cable on an MPC or MIC | 145](#)

Removing a Cable on an MPC or MIC

Removing and installing cables on an MPC or MIC does not affect router function.

To remove a cable:

1. Have ready a rubber safety cap for each fiber-optic cable and transceiver.
2. If removing all cables connected to the component, use one of the following methods to take the component offline:
 - To take an MPC offline:
 - Press and hold the corresponding **OFFLINE** button on the MPC. The green **OK/FAIL** LED next to the button begins to blink. Hold the button down until the LED goes off. Use a narrow-ended tool that fits inside the opening that leads to the button.

- Issue the following CLI command:

```
user@host>request chassis fpc slot slot-number offline
```

For more information about the command, see the [CLI Explorer](#).

- To take a MIC offline:
 - Press the **OFFLINE** button on the MIC. Use a narrow-ended tool that fits inside the opening that leads to the button. Press and hold the button until the MIC's **OK/FAIL** LED goes off (about 5 seconds). Use a narrow-ended tool that fits inside the opening that leads to the button.
 - Issue the following CLI command:

```
user@host> request chassis pic fpc-slot fpc-slot pic-slot pic-slot offline
```

For more information about the command, see the [CLI Explorer](#).

3. Disconnect the cable from the cable connector port. If the component uses fiber-optic cable, immediately cover each transceiver and the end of each cable with a rubber safety cap.



LASER WARNING: Do not look directly into a fiber-optic transceiver or into the ends of fiber-optic cables. Fiber-optic transceivers and fiber-optic cables connected to a transceiver emit laser light that can damage your eyes.



CAUTION: Do not leave a fiber-optic transceiver uncovered, except when you are inserting or removing cable. The safety cap keeps the port clean and protects your eyes from accidental exposure to laser light.

4. Remove the cable from the cable management brackets.
5. Disconnect the cable from the destination port.

Installing a Cable on an MPC or MIC

To install a cable:

1. Have ready a length of the type of cable used by the MPC or MIC. For cable specifications, see the [MX Series Interface Module Reference](#).
2. If the cable connector port is covered by a rubber safety plug, remove the plug.



LASER WARNING: Do not look directly into a fiber-optic transceiver or into the ends of fiber-optic cables. Fiber-optic transceivers and fiber-optic cables connected to a transceiver emit laser light that can damage your eyes.



CAUTION: Do not leave a fiber-optic transceiver uncovered, except when you are inserting or removing cable. The safety cap keeps the port clean and protects your eyes from accidental exposure to laser light.

3. Insert the cable connector into the cable connector port on the component faceplate.
4. Arrange the cable in the cable management brackets to prevent it from dislodging or developing stress points. Secure the cable so that it is not supporting its own weight as it hangs to the floor. Place excess cable out of the way in a neatly coiled loop. Placing fasteners on the loop helps to maintain its shape.



CAUTION: Do not let fiber-optic cables hang free from the connector. Do not allow the fastened loops of a cable to dangle, which stresses the cable at the fastening point.



CAUTION: Do not bend a fiber-optic cable beyond its minimum bend radius. An arc smaller than a few inches in diameter can damage the cable and cause problems that are difficult to diagnose.

5. Insert the other end of the cable into the destination port.
6. Repeat the previous steps for any additional cables.
7. If the component is offline (its failure indicator LED is lit), use one of the following methods to bring the it online:
 - To bring an MPC online:
 - Press and hold the **OFFLINE** button on the MPC until the green **OK** LED next to the button lights steadily, in about 5 seconds. Use a narrow-ended tool that fits inside the opening that leads to the button.
 - Issue the following CLI command:

```
user@host>request chassis fpc slot slot-number online
```

For more information about the command, see the [CLI Explorer](#).

- To bring a MIC online:
 - Press the MIC **OFFLINE** button until the **OK/FAIL** LED lights green. Use a narrow-ended tool that fits inside the opening that leads to the button.
 - Issue the following CLI command:

```
user@host>request chassis pic fpc-slot fpc-slot pic-slot pic-slot online
```

For more information about the command, see the [CLI Explorer](#).

The normal functioning indicator LED confirms that the component is online. You can also verify correct DPC or MPC functioning by issuing the `show chassis fpc` command or correct MIC or the PIC functioning by issuing the `show chassis fpc pic-status` command.

RELATED DOCUMENTATION

[Routine Maintenance Procedures for MX10003 Routers | 105](#)

[Prevention of Electrostatic Discharge Damage | 173](#)

Replace an SFP, SFP+, or QSFP+ Transceiver

IN THIS SECTION

● [Remove a Transceiver | 147](#)

● [Install a Transceiver | 149](#)

The transceivers for Juniper Networks devices are hot-removable and hot-insertable field-replaceable units (FRUs). You can remove and replace them without powering off the device or disrupting the device functions.

Remove a Transceiver

Before you begin removing a transceiver from a device, ensure that you have taken the necessary precautions for the safe handling of lasers (see *Laser and LED Safety Guidelines and Warnings*).

Ensure that you have the following parts and tools available:

- An antistatic bag or an antistatic mat
- Rubber safety caps to cover the transceiver and fiber-optic cable connector
- A dust cover to cover the port or a replacement transceiver

NOTE: After you remove a transceiver or when you change the media-type configuration, wait for 6 seconds for the interface to display the operational commands.

To remove a transceiver:

1. Place the antistatic bag or antistatic mat on a flat, stable surface.
2. Wrap and fasten one end of the ESD grounding strap around your bare wrist, and connect the other end of the strap to an ESD point.
3. Label the cables connected to the transceiver so that you can reconnect them correctly later.
4. Remove the cable connected to the transceiver (see *Disconnect a Fiber-Optic Cable*). Cover the transceiver and the end of each fiber-optic cable connector with a rubber safety cap immediately after disconnecting the fiber-optic cables.



LASER WARNING: Do not look directly into a fiber-optic transceiver or into the ends of fiber-optic cables. Fiber-optic transceivers and fiber-optic cables connected to a transceiver emit laser light that can damage your eyes.



LASER WARNING: Do not leave a fiber-optic transceiver uncovered except when inserting or removing a cable. The rubber safety cap keeps the port clean and prevents accidental exposure to laser light.

5. If there is a cable management system, arrange the cable in the cable management system to prevent it from dislodging or developing stress points. Secure the cable so that it does not support its own weight as it hangs to the floor. Place excess cable out of the way in a neatly coiled loop in the cable management system. Placing fasteners on the loop helps to maintain its shape.



CAUTION: Do not bend the fiber-optic cable beyond its minimum bend radius. An arc smaller than a few inches in diameter can damage the cable and cause problems that are difficult to diagnose.

- By using your fingers, pull open the ejector lever on the transceiver to unlock the transceiver.



CAUTION: Ensure that you open the ejector handle completely until you hear it click. Doing this prevents damage to the transceiver.

Figure 6 shows how to remove an SFP transceiver. The procedure is the same for SFP+ and QSFP+ transceivers.

Figure 53: Small Form-Factor Pluggable (SFP) Transceiver

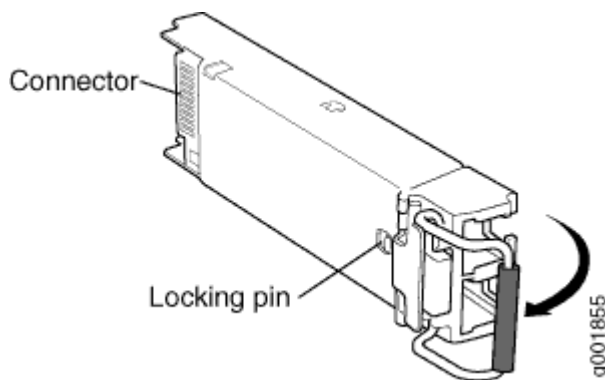

- Grasp the transceiver ejector handle, and pull the transceiver approximately 0.5 in. (1.3 cm) out of the interface port.
- Using your fingers, grasp the body of the transceiver, and pull it the rest of the way out of the interface port.
- Place a rubber safety cap over the transceiver.
- Place the removed transceiver on an antistatic mat or in an electrostatic bag.
- Place the dust cover over the empty port or install the replacement transceiver.



CAUTION: After removing a transceiver from the chassis, wait at least 30 seconds before reinserting it or inserting a transceiver into a different slot.

Install a Transceiver

Before you begin to install a transceiver in a device, ensure that you have taken the necessary precautions for safe handling of lasers (see *Laser and LED Safety Guidelines and Warnings*).

Ensure that you have a rubber safety cap available to cover the transceiver.

NOTE: After you insert a transceiver or after you change the media-type configuration, wait for 6 seconds for the interface to display operational commands.

NOTE: We recommend that you use only optical transceivers and optical connectors purchased from Juniper Networks with your Juniper Networks device.



CAUTION: The Juniper Networks Technical Assistance Center (JTAC) provides complete support for Juniper-supplied optical modules and cables. However, JTAC does not provide support for third-party optical modules and cables that are not qualified or supplied by Juniper Networks. If you face a problem running a Juniper device that uses third-party optical modules or cables, JTAC may help you diagnose host-related issues if the observed issue is not, in the opinion of JTAC, related to the use of the third-party optical modules or cables. Your JTAC engineer will likely request that you check the third-party optical module or cable and, if required, replace it with an equivalent Juniper-qualified component.

Use of third-party optical modules with high-power consumption (for example, coherent ZR or ZR+) can potentially cause thermal damage to or reduce the lifespan of the host equipment. Any damage to the host equipment due to the use of third-party optical modules or cables is the users' responsibility. Juniper Networks will accept no liability for any damage caused due to such use.

To install a transceiver:

1. Attach an ESD grounding strap to your bare wrist, and connect the other end of the strap to an ESD grounding point.
2. Remove the transceiver from its bag.
3. Verify that each transceiver is covered by a rubber safety cap. If it is not, cover the transceiver with a safety cap.



LASER WARNING: Do not leave a fiber-optic transceiver uncovered except when inserting or removing a cable. The rubber safety cap keeps the port clean and prevents accidental exposure to laser light.

4. Using both hands, carefully place the transceiver in the empty port. The connectors must face the chassis.



CAUTION: Before you slide the transceiver into the port, ensure that the transceiver is aligned correctly. Misalignment might cause the pins to bend, making the transceiver unusable.

- Slide in the transceiver until it is fully seated. If you are unable to fully insert the transceiver, ensure that the connector is facing the right way.

Figure 54: Install a Transceiver

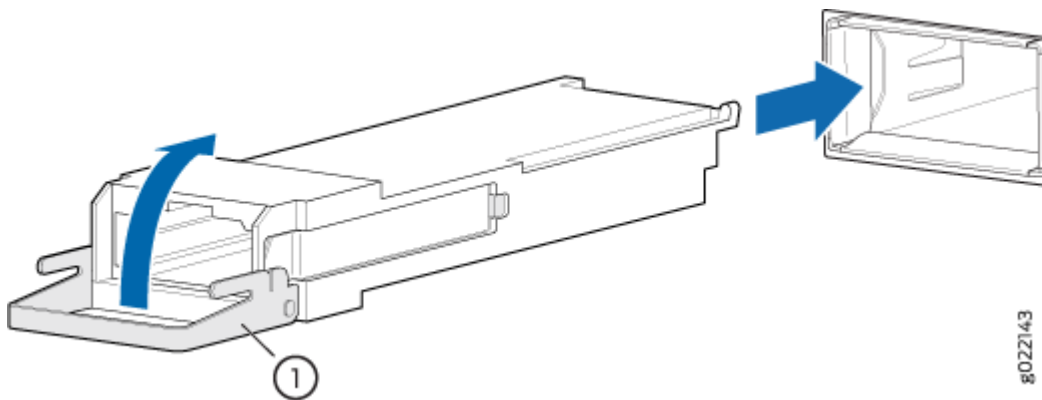

1– Ejector lever

- Close the ejector handle of the transceiver.
- Remove the rubber safety cap from the transceiver and from the end of the cable. Insert the cable into the transceiver.



LASER WARNING: Do not look directly into a fiber-optic transceiver or into the ends of fiber-optic cables. Fiber-optic transceivers and fiber-optic cables connected to a transceiver emit laser light that can damage your eyes.

Replace a QSFP28 Transceiver

IN THIS SECTION

- Remove a QSFP28 Transceiver | 152

28-Gbps quad small form-factor pluggable (QSFP28) transceivers are hot-insertable and hot-removable. Removing a QSFP28 transceiver does not interrupt router functioning, but the removed QSFP28 transceiver no longer receives or transmits data.

Remove a QSFP28 Transceiver

Before you begin to remove a transceiver from a device, ensure that you have taken the necessary precautions for safe handling of lasers (see *Laser and LED Safety Guidelines and Warnings*).

Ensure that you have the following parts and tools available:

- An antistatic bag or an antistatic mat
- Rubber safety caps to cover the transceiver and fiber-optic cable connector
- A dust cover to cover the port or a replacement transceiver

The transceivers for Juniper Networks devices are hot-removable and hot-insertable field-replaceable units (FRUs). You can remove and replace them without powering off the device or disrupting the device functions.

NOTE: After you insert a transceiver or after you change the media-type configuration, wait for 6 seconds for the interface to display operational commands.

NOTE: We recommend that you use only optical transceivers and optical connectors purchased from Juniper Networks with your Juniper Networks device.

To remove a QSFP28 transceiver (see Figure 8):

1. Place an electrostatic bag or antistatic mat on a flat, stable surface to receive the QSFP28 transceiver. Have ready a rubber safety cap for the QSFP28 transceiver and the cable.
2. Wrap and fasten one end of the ESD grounding strap around your bare wrist, and connect the other end of the strap to an ESD point.
3. Label the cable connected to the QSFP28 transceiver so that you can later reconnect the cable to the correct QSFP28 transceiver.

4. Disconnect the cable from the transceiver. Immediately cover the transceiver and the end of the cable with a rubber safety cap.



LASER WARNING: Do not look directly into a fiber-optic transceiver or into the ends of fiber-optic cables. Fiber-optic transceivers and fiber-optic cable connected to a transceiver emit laser light that can damage your eyes.



CAUTION: Do not leave a fiber-optic transceiver uncovered, except when inserting or removing a cable. The safety cap keeps the port clean and protects your eyes from accidental exposure to laser light.

5. If there is a cable management system, arrange the cable in the cable management system to prevent it from dislodging or developing stress points. Secure the cable so that it does not support its own weight as it hangs to the floor. Place excess cable out of the way in a neatly coiled loop in the cable management system. Placing fasteners on the loop helps to maintain its shape.



CAUTION: Avoid bending the fiber-optic cable beyond its minimum bend radius. An arc smaller than a few inches in diameter can damage the cable and cause problems that are difficult to diagnose.

6. Pull the transceiver's rubber handle straight back.
The locking pins on the transceiver automatically releases the transceiver.

Figure 55: 28-Gbps Quad Small Form-Factor Pluggable (QSFP28) Transceiver

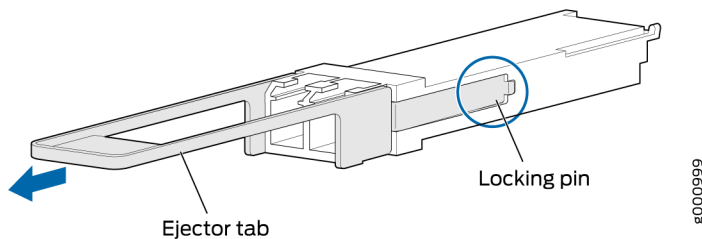

7. Place the transceiver on the antistatic mat or in the electrostatic bag.
8. Place the dust cover over the empty port or install the replacement transceiver.

Install a QSFP28 Transceiver

Before you begin to install a transceiver in a device, ensure that you have taken the necessary precautions for safe handling of lasers (see *Laser and LED Safety Guidelines and Warnings*).

Ensure that you have a rubber safety cap available to cover the transceiver.

The transceivers for Juniper Networks devices are hot-removable and hot-insertable field-replaceable units (FRUs): You can remove and replace them without powering off the device or disrupting the device functions.

NOTE: After you insert a transceiver or after you change the media-type configuration, wait for 6 seconds for the interface to display operational commands.

NOTE: We recommend that you use only optical transceivers and optical connectors purchased from Juniper Networks with your Juniper Networks device.



CAUTION: The Juniper Networks Technical Assistance Center (JTAC) provides complete support for Juniper-supplied optical modules and cables. However, JTAC does not provide support for third-party optical modules and cables that are not qualified or supplied by Juniper Networks. If you face a problem running a Juniper device that uses third-party optical modules or cables, JTAC may help you diagnose host-related issues if the observed issue is not, in the opinion of JTAC, related to the use of the third-party optical modules or cables. Your JTAC engineer will likely request that you check the third-party optical module or cable and, if required, replace it with an equivalent Juniper-qualified component.

Use of third-party optical modules with high-power consumption (for example, coherent ZR or ZR+) can potentially cause thermal damage to or reduce the lifespan of the host equipment. Any damage to the host equipment due to the use of third-party optical modules or cables is the users' responsibility. Juniper Networks will accept no liability for any damage caused due to such use.

To install a replacement QSFP28 transceiver (see [Figure 56 on page 155](#)):

1. Wrap and fasten one end of the ESD grounding strap around your bare wrist, and connect the other end of the strap to an ESD point.
2. Verify that a rubber safety cap covers the QSFP28 transceiver. If it is not, cover the transceiver with a safety cap.
3. Orient the transceiver in front of the port so that the QSFP28 connector faces the appropriate direction.

Figure 56: Install a QSFP28 Transceiver

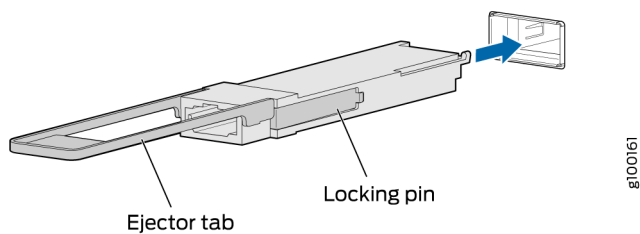

4. Slide the transceiver into the slot until the locking pins lock in place. If there is resistance, remove the transceiver and flip it so that the connector faces the other direction.
5. Remove the rubber safety cap from the transceiver and from the end of the cable, and insert the cable into the transceiver.



LASER WARNING: Do not look directly into a fiber-optic transceiver or into the ends of fiber-optic cables. Fiber-optic transceivers and fiber-optic cable connected to a transceiver emit laser light that can damage your eyes.



CAUTION: Do not leave a fiber-optic transceiver uncovered, except when inserting or removing a cable. The safety cap keeps the port clean and protects your eyes from accidental exposure to laser light.

6. If there is a cable management system, arrange the cable in the cable management system to prevent the cable from dislodging or developing stress points. Secure the cable so that it does not support its own weight as it hangs to the floor. Place excess cable out of the way in a neatly coiled loop in the cable management system. Placing fasteners on the loop helps to maintain its shape.



CAUTION: Do not let the fiber-optic cable hang free from the connector. Do not allow fastened loops of the cable to dangle, which stresses the cable at the fastening point.



CAUTION: Avoid bending the fiber-optic cable beyond its minimum bend radius. An arc smaller than a few inches in diameter can damage the cable and cause problems that are difficult to diagnose.

7. Verify that the status LEDs on the router indicate that the QSFP28 transceiver is functioning correctly. You can also verify that the interface port is functioning by running the `show chassis fpc pic-status` command.

5

CHAPTER

Contacting Customer Support and Returning the Chassis or Components

Contacting Customer Support and Returning the Chassis or Components | 158

Contacting Customer Support and Returning the Chassis or Components

IN THIS SECTION

- [Contact Customer Support to Obtain a Return Material Authorization | 158](#)
- [Locating the Serial Number on a MX10003 Router or Component | 159](#)
- [Guidelines for Packing Hardware Components for Shipment | 164](#)

Contact Customer Support to Obtain a Return Material Authorization

If you need to return a device or hardware component to Juniper Networks for repair or replacement, obtain an RMA number from JTAC. You must obtain an RMA number before you attempt to return the component.

After locating the serial number of the device or hardware component you want to return, open a service request with the JTAC on the Web or by telephone.

Before you request an RMA number from JTAC, be prepared to provide the following information:

- Your existing service request number, if you have one
- Serial number of the component
- Your name, organization name, telephone number, fax number, and shipping address
- Details of the failure or problem
- Type of activity being performed on the device when the problem occurred
- Configuration data displayed by one or more `show` commands

You can contact JTAC 24 hours a day, seven days a week, on the Web or by telephone:

- Service Request Manager: <https://support.juniper.net/support>
- Telephone: +1-888-314-JTAC (+1-888-314-5822), toll free in U.S., Canada, and Mexico

NOTE: For international or direct-dial options in countries without toll free numbers, see <https://support.juniper.net/support>.

If you are contacting JTAC by telephone, enter your 12-digit service request number followed by the pound (#) key for an existing case, or press the star (*) key to be routed to the next available support engineer.

The support representative validates your request and issues an RMA number for return of the component.

Locating the Serial Number on a MX10003 Router or Component

IN THIS SECTION

- [Listing the Chassis and Component Details Using the CLI | 160](#)
- [Locating the Chassis Serial Number ID Label on a MX10003 | 161](#)
- [Locating the Serial Number ID Labels on MX10003 Power Supplies | 161](#)
- [Locating the Serial Number ID Label on MX10003 Fan Module | 162](#)
- [Locating the Serial Number ID Labels on MX10003 Line Cards | 162](#)
- [Locating the Serial Number ID Labels on MX10003 Routing and Control Board \(RCB\) | 163](#)
- [Locating the Serial Number ID Label on a MX10003 SATA SSD | 164](#)

If you are returning a router or component to Juniper Networks for repair or replacement, you must locate the serial number of the router or component. You must provide the serial number to the Juniper Networks Technical Assistance Center (JTAC) when you contact them to obtain a Return Materials Authorization (RMA). See "[Contacting Customer Support and Returning the Chassis or Components](#)" on [page 158](#).

If the router is operational and you can access the command-line interface (CLI), you can list serial numbers for the router and for some components with a CLI command. If you do not have access to the CLI or if the serial number for the component does not appear in the command output, you can locate the serial number ID label on the router or component.

NOTE: If you want to find the serial number ID label on a component, you need to remove the component from the router chassis, for which you must have the required parts and tools available.

Listing the Chassis and Component Details Using the CLI

To list the MX10003 chassis and the components and their serial numbers, use the `show chassis hardware` CLI operational mode command.

```

user@device> show chassis hardware
Hardware inventory:
Item           Version  Part number  Serial number  Description
Chassis                AF209      JNP10003 [MX10003]
Midplane             REV 01   750-066883  CAGZ6546      Midplane 2
Routing Engine 0      BUILTIN  BUILTIN     RE-S-2X00x6
CB 0                 REV 10   750-067071  CAGZ9916      Control Board
  Mezz                REV 06   711-066896  CAGS1711      Control Mezz Board
FPC 0                 REV 05   750-066879  CAGV0280      LC2103
  CPU                  BUILTIN  BUILTIN     SMPC PMB
  PIC 0                BUILTIN  BUILTIN     6xQSFP
    Xcvr 0             REV 01   740-054053  QF310124      QSFP+-4X10G-SR
    Xcvr 1             REV 01   740-032986  QD417082      QSFP+-40G-SR4
  PIC 1               REV 05   750-069305  CAGX1011      MIC1-MACSEC
    Xcvr 4             REV 01   740-067443  XW40EAK       QSFP+-40G-SR4
    Xcvr 10            REV 01   740-046565  XU70N7F       QSFP+-40G-SR4
    Xcvr 11            REV 01   740-046565  XU70N6B       QSFP+-40G-SR4
FPC 1                 REV 05   750-066879  CAGV0284      LC2103
  CPU                  BUILTIN  BUILTIN     SMPC PMB
  PIC 0                BUILTIN  BUILTIN     6xQSFP
    Xcvr 0             REV 01   740-054053  XW30F2L       QSFP+-4X10G-SR
  PIC 1               REV 05   750-069305  CAGX1003      MIC1-MACSEC
PEM 0                 REV 01   740-066937  1HS16500013   JNP-PWR1600-AC
PEM 1                 REV 01   740-066937  1HS16500015   JNP-PWR1600-AC
PEM 2                 REV 01   740-066937  1HS16500014   JNP-PWR1600-AC
PEM 3                 REV 01   740-066937  1HS16500018   JNP-PWR1600-AC
Fan Tray 0            REV 02   760-069329  CAGS7662      JNP FAN 3RU
Fan Tray 1            REV 02   760-069329  CAHA9105      JNP FAN 3RU
Fan Tray 2            REV 02   760-069329  CAHA9144      JNP FAN 3RU
Fan Tray 3            REV 02   760-069329  CAGS7759      JNP FAN 3RU

```

Locating the Chassis Serial Number ID Label on a MX10003

The serial number ID label is located on a label on the top of the chassis. See [Figure 57 on page 161](#) for the location on a MX10003.

Figure 57: MX10003 Serial Number Label

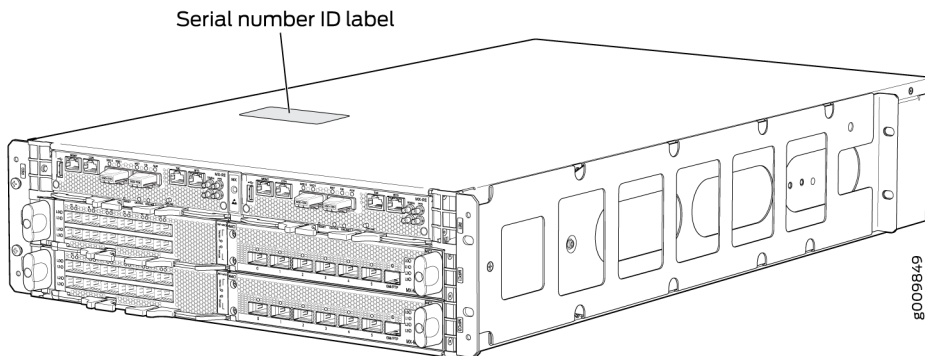

Locating the Serial Number ID Labels on MX10003 Power Supplies

The power supplies installed in a MX10003 are field-replaceable units (FRUs). For each FRU, you must remove the FRU from the router chassis to see the FRU serial number ID label.

- AC power supply—The serial number ID label is on the top of the AC power supply. See [Figure 58 on page 161](#).

Figure 58: MX10003 AC Power Supply Serial Number Location

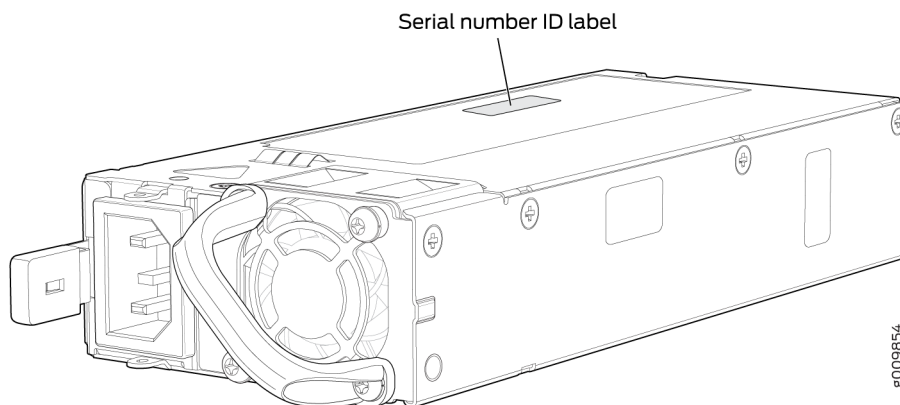

- DC power supply—The serial number ID label is on the top of the DC power supply. See [Figure 59 on page 162](#).

Figure 59: MX10003 DC Power Supply Serial Number Location

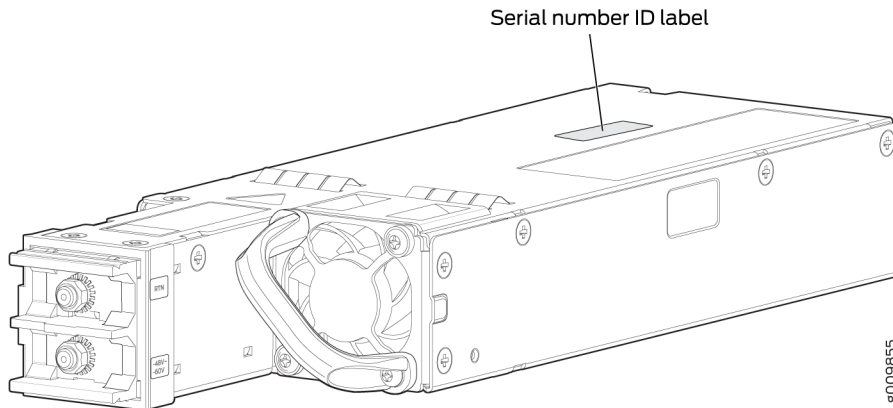

Locating the Serial Number ID Label on MX10003 Fan Module

The four fan modules installed in a MX10003 are field-replaceable units (FRUs). For each FRU, you must remove the FRU from the router chassis to see the FRU serial number ID label.

Fan module—The serial number ID label is located at the base of the fan module. See [Figure 60 on page 162](#).

Figure 60: MX10003 Fan Module Serial Number Location

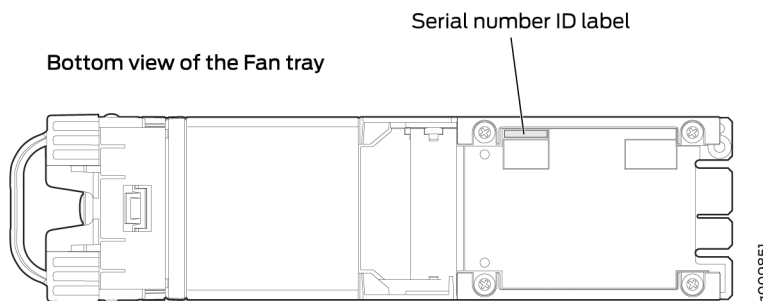

Locating the Serial Number ID Labels on MX10003 Line Cards

The serial number ID label for an MX10003 MPC is located on the connector end of the card. See [Figure 61 on page 163](#).

Figure 61: MX10003 MPC Serial Number Location

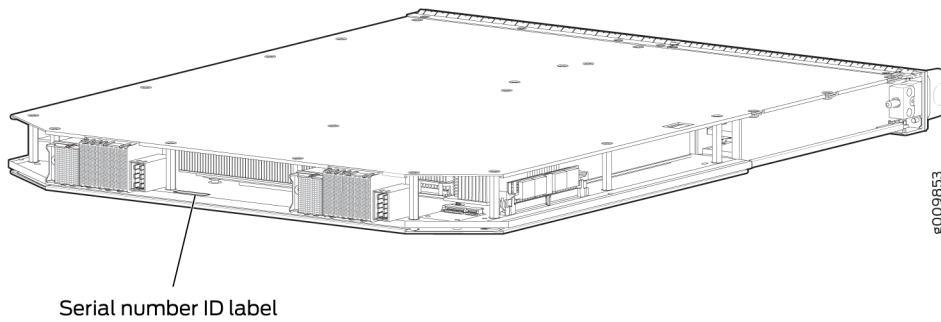

The serial number ID label for an MX10003 MIC is located on the connector end of the card. See [Figure 62 on page 163](#).

Figure 62: MX10003 MIC Serial Number Location

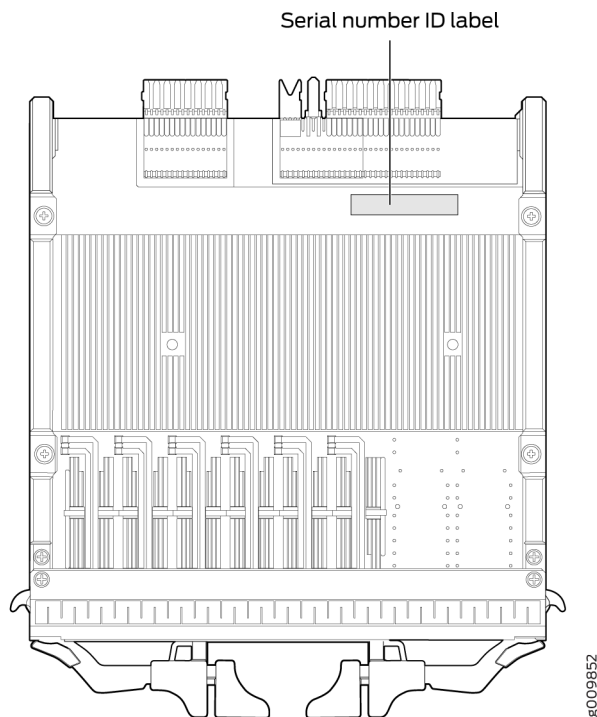

Locating the Serial Number ID Labels on MX10003 Routing and Control Board (RCB)

The serial number ID label for an MX10003 RCB is located on the connector end of the card. See [Figure 63 on page 164](#).

Figure 63: MX10003 RCB Serial Number Location

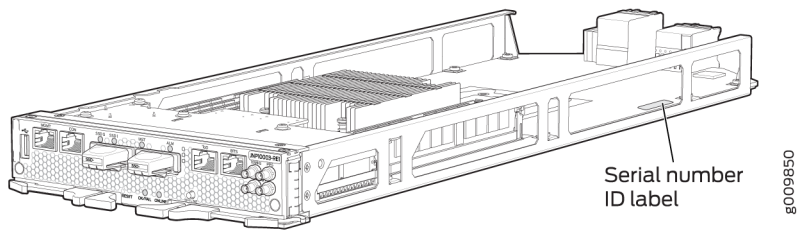

Locating the Serial Number ID Label on a MX10003 SATA SSD

The serial number for a SATA SSD is located on top of the drive. See [Figure 64 on page 164](#).

Figure 64: MX10003 SATA SSD Serial Number Location

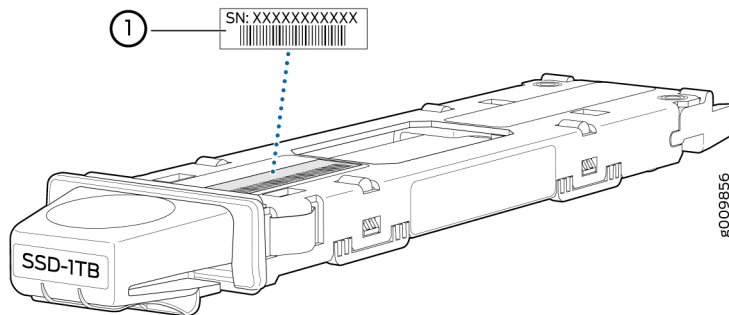

RELATED DOCUMENTATION

[MX10003 Hardware Components and CLI Terminology | 4](#)

Guidelines for Packing Hardware Components for Shipment

To pack and ship individual components:

- When you return components, make sure that they are adequately protected with packing materials and packed so that the pieces are prevented from moving around inside the carton.
- Use the original shipping materials if they are available.

- Place individual components in antistatic bags.
- Write the RMA number on the exterior of the box to ensure proper tracking.



CAUTION: Do not stack any of the hardware components.



Safety and Compliance Information

Definitions of Safety Warning Levels | 168

General Safety Guidelines and Warnings | 169

General Safety Warnings for Juniper Networks Devices | 171

Prevention of Electrostatic Discharge Damage | 173

Fire Safety Requirements | 175

Installation Instructions Warning | 176

Chassis and Component Lifting Guidelines | 177

Ramp Warning | 178

Rack-Mounting and Cabinet-Mounting Warnings | 178

Laser and LED Safety Guidelines and Warnings | 182

Radiation from Open Port Apertures Warning | 185

Maintenance and Operational Safety Guidelines and Warnings | 186

General Electrical Safety Guidelines and Warnings | 192

Prevention of Electrostatic Discharge Damage | 193

Site Electrical Wiring Guidelines | 195

AC Power Electrical Safety Guidelines | 196

AC Power Disconnection Warning | 197

DC Power Disconnection Warning | 198

DC Power Grounding Requirements and Warning | 199

DC Power Wiring Sequence Warning | 200

[DC Power Wiring Terminations Warning | 202](#)

[Multiple Power Supplies Disconnection Warning | 203](#)

[TN Power Warning | 204](#)

[Action to Take After an Electrical Accident | 204](#)

[Agency Approvals for MX10003 Router | 205](#)

[Compliance Statements for Data Center | 207](#)

[Compliance Statements for EMC Requirements | 207](#)

[Compliance Statements for Environmental Requirements | 209](#)

[Compliance Statements for Acoustic Noise for MX10003 Router | 209](#)

[Statements of Volatility for Juniper Network Devices | 209](#)

Definitions of Safety Warning Levels

The documentation uses the following levels of safety warnings (there are two *Warning* formats):

NOTE: You might find this information helpful in a particular situation, or you might overlook this important information if it was not highlighted in a Note.



CAUTION: You need to observe the specified guidelines to prevent minor injury or discomfort to you or severe damage to the device.

Attention Veillez à respecter les consignes indiquées pour éviter toute incommodité ou blessure légère, voire des dégâts graves pour l'appareil.



LASER WARNING: This symbol alerts you to the risk of personal injury from a laser.

Avertissement Ce symbole signale un risque de blessure provoquée par rayon laser.



WARNING: This symbol means danger. You are in a situation that could cause bodily injury. Before you work on any equipment, be aware of the hazards involved with electrical circuitry, and familiarize yourself with standard practices for preventing accidents.

Waarschuwing Dit waarschuwingssymbool betekent gevaar. U verkeert in een situatie die lichamelijk letsel kan veroorzaken. Voordat u aan enige apparatuur gaat werken, dient u zich bewust te zijn van de bij elektrische schakelingen betrokken risico's en dient u op de hoogte te zijn van standaard maatregelen om ongelukken te voorkomen.

Varoitus Tämä varoitusmerkki merkitsee vaaraa. Olet tilanteessa, joka voi johtaa ruumiinvammaan. Ennen kuin työskentelet minkään laitteiston parissa, ota selvää sähkökytkentöihin liittyvistä vaaroista ja tavanomaisista onnettomuuksien ehkäisykeinoista.

Avertissement Ce symbole d'avertissement indique un danger. Vous vous trouvez dans une situation pouvant causer des blessures ou des dommages corporels. Avant de travailler sur un équipement, soyez conscient des dangers posés par les circuits électriques et familiarisez-vous avec les procédures couramment utilisées pour éviter les accidents.

Warnung Dieses Warnsymbol bedeutet Gefahr. Sie befinden sich in einer Situation, die zu einer Körperverletzung führen könnte. Bevor Sie mit der Arbeit an irgendeinem Gerät beginnen, seien Sie sich der mit elektrischen Stromkreisen verbundenen Gefahren und der Standardpraktiken zur Vermeidung von Unfällen bewusst.

Avvertenza Questo simbolo di avvertenza indica un pericolo. La situazione potrebbe causare infortuni alle persone. Prima di lavorare su qualsiasi apparecchiatura, occorre conoscere i pericoli relativi ai circuiti elettrici ed essere al corrente delle pratiche standard per la prevenzione di incidenti.

Advarsel Dette varselsymbolet betyr fare. Du befinner deg i en situasjon som kan føre til personskade. Før du utfører arbeid på utstyr, må du være oppmerksom på de faremomentene som elektriske kretser innebærer, samt gjøre deg kjent med vanlig praksis når det gjelder å unngå ulykker.

Aviso Este símbolo de aviso indica perigo. Encontra-se numa situação que lhe poderá causar danos físicos. Antes de começar a trabalhar com qualquer equipamento, familiarize-se com os perigos relacionados com circuitos eléctricos, e com quaisquer práticas comuns que possam prevenir possíveis acidentes.

¡Atención! Este símbolo de aviso significa peligro. Existe riesgo para su integridad física. Antes de manipular cualquier equipo, considerar los riesgos que entraña la corriente eléctrica y familiarizarse con los procedimientos estándar de prevención de accidentes.

Varning! Denna varningssymbol signalerar fara. Du befinner dig i en situation som kan leda till personskada. Innan du utför arbete på någon utrustning måste du vara medveten om farorna med elkretsar och känna till vanligt förfarande för att förebygga skador.

General Safety Guidelines and Warnings

The following guidelines help ensure your safety and protect the device from damage. The list of guidelines might not address all potentially hazardous situations in your working environment, so be alert and exercise good judgment at all times.

- Perform only the procedures explicitly described in the hardware documentation for this device. Make sure that only authorized service personnel perform other system services.
- Keep the area around the device clear and free from dust before, during, and after installation.
- Keep tools away from areas where people could trip over them while walking.

- Do not wear loose clothing or jewelry, such as rings, bracelets, or chains, which could become caught in the device.
- Wear safety glasses if you are working under any conditions that could be hazardous to your eyes.
- Do not perform any actions that create a potential hazard to people or make the equipment unsafe.
- Never attempt to lift an object that is too heavy for one person to handle.
- Never install or manipulate wiring during electrical storms.
- Never install electrical jacks in wet locations unless the jacks are specifically designed for wet environments.
- Operate the device only when it is properly grounded.
- Follow the instructions in this guide to properly ground the device to earth.
- Replace fuses only with fuses of the same type and rating.
- Do not open or remove chassis covers or sheet-metal parts unless instructions are provided in the hardware documentation for this device. Such an action could cause severe electrical shock.
- Do not push or force any objects through any opening in the chassis frame. Such an action could result in electrical shock or fire.
- Avoid spilling liquid onto the chassis or onto any device component. Such an action could cause electrical shock or damage the device.
- Avoid touching uninsulated electrical wires or terminals that have not been disconnected from their power source. Such an action could cause electrical shock.
- Some parts of the chassis, including AC and DC power supply surfaces, power supply unit handles, SFB card handles, and fan tray handles might become hot. The following label provides the warning for hot surfaces on the chassis:



- Always ensure that all modules, power supplies, and cover panels are fully inserted and that the installation screws are fully tightened.

General Safety Warnings for Juniper Networks Devices

IN THIS SECTION

- [Qualified Personnel Warning | 171](#)
- [Restricted-Access Area Warning | 172](#)

Qualified Personnel Warning



WARNING: Only trained and qualified personnel should install or replace the hardware equipment.

Waarschuwing Installatie en reparaties mogen uitsluitend door getraind en bevoegd personeel uitgevoerd worden.

Varoitus Ainoastaan koulutettu ja pätevä henkilökunta saa asentaa tai vaihtaa tämän laitteen.

Attention Tout installation ou remplacement de l'appareil doit être réalisé par du personnel qualifié et compétent.

Warnung Gerät nur von geschultem, qualifiziertem Personal installieren oder auswechseln lassen.

Avvertenza Solo personale addestrato e qualificato deve essere autorizzato ad installare o sostituire questo apparecchio.

Advarsel Kun kvalifisert personell med riktig opplæring bør montere eller bytte ut dette utstyret.

Aviso Este equipamento deverá ser instalado ou substituído apenas por pessoal devidamente treinado e qualificado.

¡Atención! Estos equipos deben ser instalados y reemplazados exclusivamente por personal técnico adecuadamente preparado y capacitado.

Warning! Denna utrustning ska endast installeras och bytas ut av utbildad och kvalificerad personal.

Restricted-Access Area Warning



WARNING: The hardware equipment is intended for installation in restricted-access areas. A restricted-access area is an area to which access can be gained only by service personnel through the use of a special tool, lock and key, or other means of security, and which is controlled by the authority responsible for the location.

Waarschuwing Dit toestel is bedoeld voor installatie op plaatsen met beperkte toegang. Een plaats met beperkte toegang is een plaats waar toegang slechts door servicepersoneel verkregen kan worden door middel van een speciaal instrument, een slot en sleutel, of een ander veiligheidsmiddel, en welke beheerd wordt door de overheidsinstantie die verantwoordelijk is voor de locatie.

Varoitus Tämä laite on tarkoitettu asennettavaksi paikkaan, johon pääsy on rajoitettua. Paikka, johon pääsy on rajoitettua, tarkoittaa paikkaa, johon vain huoltohenkilöstö pääsee jonkin erikoistyökalun, lukkoon sopivan avaimen tai jonkin muun turvalaitteen avulla ja joka on paikasta vastuussa olevien toimivaltaisten henkilöiden valvoma.

Attention Cet appareil est à installer dans des zones d'accès réservé. Ces dernières sont des zones auxquelles seul le personnel de service peut accéder en utilisant un outil spécial, un mécanisme de verrouillage et une clé, ou tout autre moyen de sécurité. L'accès aux zones de sécurité est sous le contrôle de l'autorité responsable de l'emplacement.

Warnung Diese Einheit ist zur Installation in Bereichen mit beschränktem Zutritt vorgesehen. Ein Bereich mit beschränktem Zutritt ist ein Bereich, zu dem nur Wartungspersonal mit einem Spezialwerkzeugs, Schloß und Schlüssel oder anderer Sicherheitsvorkehrungen Zugang hat, und der von dem für die Anlage zuständigen Gremium kontrolliert wird.

Avvertenza Questa unità deve essere installata in un'area ad accesso limitato. Un'area ad accesso limitato è un'area accessibile solo a personale di assistenza tramite un'attrezzo speciale, lucchetto, o altri dispositivi di sicurezza, ed è controllata dall'autorità responsabile della zona.

Advarsel Denne enheten er laget for installasjon i områder med begrenset adgang. Et område med begrenset adgang gir kun adgang til servicepersonale som bruker et

spesielt verktøy, lås og nøkkel, eller en annen sikkerhetsanordning, og det kontrolleres av den autoriteten som er ansvarlig for området.

Aviso Esta unidade foi concebida para instalação em áreas de acesso restrito. Uma área de acesso restrito é uma área à qual apenas tem acesso o pessoal de serviço autorizado, que possua uma ferramenta, chave e fechadura especial, ou qualquer outra forma de segurança. Esta área é controlada pela autoridade responsável pelo local.

¡Atención! Esta unidad ha sido diseñada para instalarse en áreas de acceso restringido. Área de acceso restringido significa un área a la que solamente tiene acceso el personal de servicio mediante la utilización de una herramienta especial, cerradura con llave, o algún otro medio de seguridad, y que está bajo el control de la autoridad responsable del local.

Varning! Denna enhet är avsedd för installation i områden med begränsat tillträde. Ett område med begränsat tillträde får endast tillträdas av servicepersonal med ett speciellt verktyg, lås och nyckel, eller annan säkerhetsanordning, och kontrolleras av den auktoritet som ansvarar för området.

RELATED DOCUMENTATION

Installation Safety Warnings for Juniper Networks Devices

Maintenance and Operational Safety Warnings for Juniper Networks Devices

General Electrical Safety Warnings for Juniper Networks Devices

DC Power Electrical Safety Warnings for Juniper Networks Devices

Prevention of Electrostatic Discharge Damage

Device components that are shipped in antistatic bags are sensitive to damage from static electricity. Some components can be impaired by voltages as low as 30 V. You can easily generate potentially damaging static voltages whenever you handle plastic or foam packing material or if you move components across plastic or carpets. Observe the following guidelines to minimize the potential for electrostatic discharge (ESD) damage, which can cause intermittent or complete component failures:

- Always use an ESD wrist strap when you are handling components that are subject to ESD damage, and make sure that it is in direct contact with your skin.

If a grounding strap is not available, hold the component in its antistatic bag (see [Figure 65 on page 174](#)) in one hand and touch the exposed, bare metal of the device with the other hand immediately before inserting the component into the device.



WARNING: For safety, periodically check the resistance value of the ESD grounding strap. The measurement must be in the range 1 through 10 Mohms.

Avertissement Par mesure de sécurité, vérifiez régulièrement la résistance du bracelet antistatique. Cette valeur doit être comprise entre 1 et 10 mégohms (Mohms).

- When handling any component that is subject to ESD damage and that is removed from the device, make sure the equipment end of your ESD wrist strap is attached to the ESD point on the chassis.

If no grounding strap is available, touch the exposed, bare metal of the device to ground yourself before handling the component.

- Avoid contact between the component that is subject to ESD damage and your clothing. ESD voltages emitted from clothing can damage components.
- When removing or installing a component that is subject to ESD damage, always place it component-side up on an antistatic surface, in an antistatic card rack, or in an antistatic bag (see [Figure 65 on page 174](#)). If you are returning a component, place it in an antistatic bag before packing it.

Figure 65: Placing a Component into an Antistatic Bag

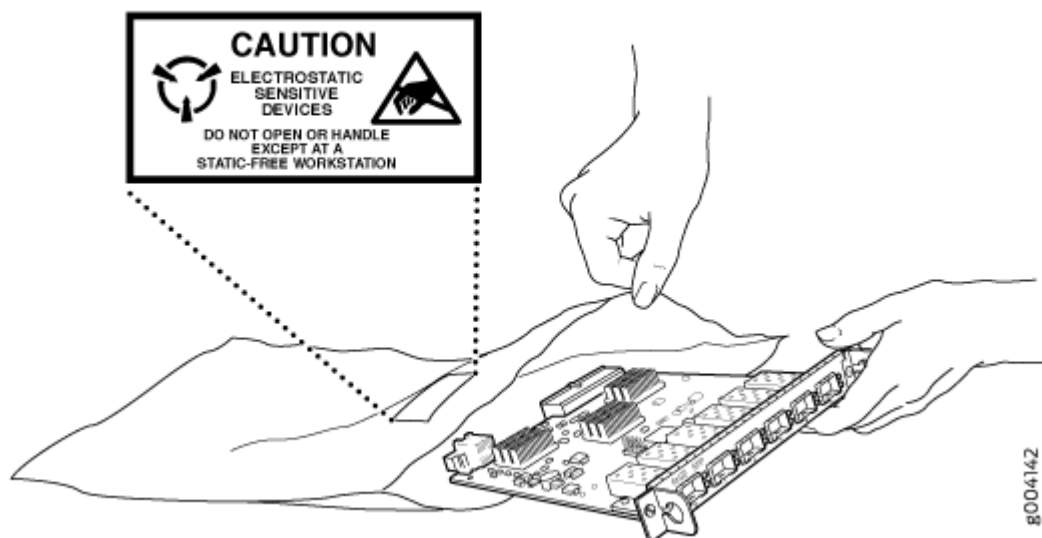

R004142



CAUTION: ANSI/TIA/EIA-568 cables such as Category 5e and Category 6 can get electrostatically charged. To dissipate this charge, always ground the cables to a suitable and safe earth ground before connecting them to the system.

Attention Les câbles ANSI/TIA/EIA-568, par exemple Cat 5e et Cat 6, peuvent emmagasiner des charges électrostatiques. Pour évacuer ces charges, reliez toujours les câbles à une prise de terre adaptée avant de les raccorder au système.

Fire Safety Requirements

IN THIS SECTION

- [Fire Suppression | 175](#)
- [Fire Suppression Equipment | 176](#)

In the event of a fire emergency, the safety of people is the primary concern. You should establish procedures for protecting people in the event of a fire emergency, provide safety training, and properly provision fire-control equipment and fire extinguishers.

In addition, you should establish procedures to protect your equipment in the event of a fire emergency. Juniper Networks products should be installed in an environment suitable for electronic equipment. We recommend that fire suppression equipment be available in the event of a fire in the vicinity of the equipment and that all local fire, safety, and electrical codes and ordinances be observed when you install and operate your equipment.

Fire Suppression

In the event of an electrical hazard or an electrical fire, you should first turn power off to the equipment at the source. Then use a Type C fire extinguisher, which uses noncorrosive fire retardants, to extinguish the fire.

Fire Suppression Equipment

Type C fire extinguishers, which use noncorrosive fire retardants such as carbon dioxide and Halotron™, are most effective for suppressing electrical fires. Type C fire extinguishers displace oxygen from the point of combustion to eliminate the fire. For extinguishing fire on or around equipment that draws air from the environment for cooling, you should use this type of inert oxygen displacement extinguisher instead of an extinguisher that leaves residues on equipment.

Do not use multipurpose Type ABC chemical fire extinguishers (dry chemical fire extinguishers). The primary ingredient in these fire extinguishers is monoammonium phosphate, which is very sticky and difficult to clean. In addition, in the presence of minute amounts of moisture, monoammonium phosphate can become highly corrosive and corrodes most metals.

Any equipment in a room in which a chemical fire extinguisher has been discharged is subject to premature failure and unreliable operation. The equipment is considered to be irreparably damaged.

NOTE: To keep warranties effective, do not use a dry chemical fire extinguisher to control a fire at or near a Juniper Networks device. If a dry chemical fire extinguisher is used, the unit is no longer eligible for coverage under a service agreement.

We recommend that you dispose of any irreparably damaged equipment in an environmentally responsible manner.

Installation Instructions Warning



WARNING: Read the installation instructions before you connect the device to a power source.

Waarschuwing Raadpleeg de installatie-aanwijzingen voordat u het systeem met de voeding verbindt.

Varoitus Lue asennusohjeet ennen järjestelmän yhdistämistä virtalähteeseen.

Avertissement Avant de brancher le système sur la source d'alimentation, consulter les directives d'installation.

Warnung Lesen Sie die Installationsanweisungen, bevor Sie das System an die Stromquelle anschließen.

Avvertenza Consultare le istruzioni di installazione prima di collegare il sistema all'alimentatore.

Advarsel Les installasjonsinstruksjonene før systemet kobles til strømkilden.

Aviso Leia as instruções de instalação antes de ligar o sistema à sua fonte de energia.

¡Atención! Ver las instrucciones de instalación antes de conectar el sistema a la red de alimentación.

Varning! Läs installationsanvisningarna innan du kopplar systemet till dess strömförsörjningsenhet.

Chassis and Component Lifting Guidelines

- Before moving the device to a site, ensure that the site meets the power, environmental, and clearance requirements.
- Before lifting or moving the device, disconnect all external cables and wires.
- As when lifting any heavy object, ensure that your legs bear most of the weight rather than your back. Keep your knees bent and your back relatively straight. Do not twist your body as you lift. Balance the load evenly and be sure that your footing is firm.
- Use the following lifting guidelines to lift devices and components:
 - Up to 39.7 lb (18 kg): One person.
 - From 39.7 lb (18 kg) to 70.5 lb (32 kg): Two or more people.
 - From 70.5 lb (32 kg) to 121.2 lb (55 kg): Three or more people.
 - Above 121.2 lb (55 kg): Use material handling systems (such as levers, slings, lifts, and so on). When this is not practical, engage specially trained persons or systems (such as riggers or movers).

Ramp Warning



WARNING: When installing the device, do not use a ramp inclined at more than 10 degrees.

Waarschuwing Gebruik een oprijplaat niet onder een hoek van meer dan 10 graden.

Varoitus Älä käytä sellaista kaltevaa pintaa, jonka kaltevuus ylittää 10 astetta.

Avertissement Ne pas utiliser une rampe dont l'inclinaison est supérieure à 10 degrés.

Warnung Keine Rampen mit einer Neigung von mehr als 10 Grad verwenden.

Avvertenza Non usare una rampa con pendenza superiore a 10 gradi.

Advarsel Bruk aldri en rampe som heller mer enn 10 grader.

Aviso Não utilize uma rampa com uma inclinação superior a 10 graus.

¡Atención! No usar una rampa inclinada más de 10 grados.

Varning! Använd inte ramp med en lutning på mer än 10 grader.

Rack-Mounting and Cabinet-Mounting Warnings

Ensure that the rack or cabinet in which the device is installed is evenly and securely supported. Uneven mechanical loading could lead to a hazardous condition.



WARNING: To prevent bodily injury when mounting or servicing the device in a rack, take the following precautions to ensure that the system remains stable. The following directives help maintain your safety:

- Install the device in a rack that is secured to the building structure.
- Mount the device at the bottom of the rack if it is the only unit in the rack.
- When mounting the device on a partially filled rack, load the rack from the bottom to the top, with the heaviest component at the bottom of the rack.

- If the rack is provided with stabilizing equipment, install the stabilizers before mounting or servicing the device in the rack.

Waarschuwing Om lichamelijk letsel te voorkomen wanneer u dit toestel in een rek monteert of het daar een servicebeurt geeft, moet u speciale voorzorgsmaatregelen nemen om ervoor te zorgen dat het toestel stabiel blijft. De onderstaande richtlijnen worden verstrekt om uw veiligheid te verzekeren:

- De Juniper Networks switch moet in een stellage worden geïnstalleerd die aan een bouwsel is verankerd.
- Dit toestel dient onderaan in het rek gemonteerd te worden als het toestel het enige in het rek is.
- Wanneer u dit toestel in een gedeeltelijk gevuld rek monteert, dient u het rek van onderen naar boven te laden met het zwaarste onderdeel onderaan in het rek.
- Als het rek voorzien is van stabiliseringshulpmiddelen, dient u de stabilisatoren te monteren voordat u het toestel in het rek monteert of het daar een servicebeurt geeft.

Varoitus Kun laite asetetaan telineeseen tai huolletaan sen ollessa telineessä, on noudatettava erityisiä varotoimia järjestelmän vakavuuden säilyttämiseksi, jotta vältetään loukkaantumiselta. Noudata seuraavia turvallisuusohjeita:

- Juniper Networks switch on asennettava telineeseen, joka on kiinnitetty rakennukseen.
- Jos telineessä ei ole muita laitteita, aseta laite telineen alaosaan.
- Jos laite asetetaan osaksi täytettyyn telineeseen, aloita kuormittaminen sen alaosasta kaikkein raskaimmalla esineellä ja siirry sitten sen yläosaan.
- Jos telinettä varten on vakaimet, asenna ne ennen laitteen asettamista telineeseen tai sen huoltamista siinä.

Avertissement Pour éviter toute blessure corporelle pendant les opérations de montage ou de réparation de cette unité en casier, il convient de prendre des précautions spéciales afin de maintenir la stabilité du système. Les directives ci-dessous sont destinées à assurer la protection du personnel:

- Le rack sur lequel est monté le Juniper Networks switch doit être fixé à la structure du bâtiment.

- Si cette unité constitue la seule unité montée en casier, elle doit être placée dans le bas.
- Si cette unité est montée dans un casier partiellement rempli, charger le casier de bas en haut en plaçant l'élément le plus lourd dans le bas.
- Si le casier est équipé de dispositifs stabilisateurs, installer les stabilisateurs avant de monter ou de réparer l'unité en casier.

Warnung Zur Vermeidung von Körperverletzung beim Anbringen oder Warten dieser Einheit in einem Gestell müssen Sie besondere Vorkehrungen treffen, um sicherzustellen, daß das System stabil bleibt. Die folgenden Richtlinien sollen zur Gewährleistung Ihrer Sicherheit dienen:

- Der Juniper Networks switch muß in einem Gestell installiert werden, das in der Gebäudestruktur verankert ist.
- Wenn diese Einheit die einzige im Gestell ist, sollte sie unten im Gestell angebracht werden.
- Bei Anbringung dieser Einheit in einem zum Teil gefüllten Gestell ist das Gestell von unten nach oben zu laden, wobei das schwerste Bauteil unten im Gestell anzubringen ist.
- Wird das Gestell mit Stabilisierungszubehör geliefert, sind zuerst die Stabilisatoren zu installieren, bevor Sie die Einheit im Gestell anbringen oder sie warten.

Avvertenza Per evitare infortuni fisici durante il montaggio o la manutenzione di questa unità in un supporto, occorre osservare speciali precauzioni per garantire che il sistema rimanga stabile. Le seguenti direttive vengono fornite per garantire la sicurezza personale:

- Il Juniper Networks switch deve essere installato in un telaio, il quale deve essere fissato alla struttura dell'edificio.
- Questa unità deve venire montata sul fondo del supporto, se si tratta dell'unica unità da montare nel supporto.
- Quando questa unità viene montata in un supporto parzialmente pieno, caricare il supporto dal basso all'alto, con il componente più pesante sistemato sul fondo del supporto.
- Se il supporto è dotato di dispositivi stabilizzanti, installare tali dispositivi prima di montare o di procedere alla manutenzione dell'unità nel supporto.

Advarsel Unngå fysiske skader under montering eller reparasjonsarbeid på denne enheten når den befinner seg i et kabinett. Vær nøye med at systemet er stabilt. Følgende retningslinjer er gitt for å verne om sikkerheten:

- Juniper Networks switch må installeres i et stativ som er forankret til bygningsstrukturen.
- Denne enheten bør monteres nederst i kabinettet hvis dette er den eneste enheten i kabinettet.
- Ved montering av denne enheten i et kabinett som er delvis fylt, skal kabinettet lastes fra bunnen og opp med den tyngste komponenten nederst i kabinettet.
- Hvis kabinettet er utstyrt med stabiliseringsutstyr, skal stabilisatorene installeres før montering eller utføring av reparasjonsarbeid på enheten i kabinettet.

Aviso Para se prevenir contra danos corporais ao montar ou reparar esta unidade numa estante, deverá tomar precauções especiais para se certificar de que o sistema possui um suporte estável. As seguintes directrizes ajudá-lo-ão a efectuar o seu trabalho com segurança:

- O Juniper Networks switch deverá ser instalado numa prateleira fixa à estrutura do edifício.
- Esta unidade deverá ser montada na parte inferior da estante, caso seja esta a única unidade a ser montada.
- Ao montar esta unidade numa estante parcialmente ocupada, coloque os itens mais pesados na parte inferior da estante, arrumando-os de baixo para cima.
- Se a estante possuir um dispositivo de estabilização, instale-o antes de montar ou reparar a unidade.

¡Atención! Para evitar lesiones durante el montaje de este equipo sobre un bastidor, oerriormente durante su mantenimiento, se debe poner mucho cuidado en que el sistema quede bien estable. Para garantizar su seguridad, proceda según las siguientes instrucciones:

- El Juniper Networks switch debe instalarse en un bastidor fijado a la estructura del edificio.
- Colocar el equipo en la parte inferior del bastidor, cuando sea la única unidad en el mismo.

- Cuando este equipo se vaya a instalar en un bastidor parcialmente ocupado, comenzar la instalación desde la parte inferior hacia la superior colocando el equipo más pesado en la parte inferior.
- Si el bastidor dispone de dispositivos estabilizadores, instalar éstos antes de montar o proceder al mantenimiento del equipo instalado en el bastidor.

Warning! För att undvika kroppsskada när du installerar eller utför underhållsarbete på denna enhet på en ställning måste du vidta särskilda försiktighetsåtgärder för att försäkra dig om att systemet står stadigt. Följande riktlinjer ges för att trygga din säkerhet:

- Juniper Networks switch måste installeras i en ställning som är förankrad i byggnadens struktur.
- Om denna enhet är den enda enheten på ställningen skall den installeras längst ned på ställningen.
- Om denna enhet installeras på en delvis fylld ställning skall ställningen fyllas nedifrån och upp, med de tyngsta enheterna längst ned på ställningen.
- Om ställningen är försedd med stabiliseringsdon skall dessa monteras fast innan enheten installeras eller underhålls på ställningen.

Laser and LED Safety Guidelines and Warnings

IN THIS SECTION

- [General Laser Safety Guidelines | 183](#)
- [Class 1 Laser Product Warning | 183](#)
- [Class 1 LED Product Warning | 184](#)
- [Laser Beam Warning | 184](#)

Juniper Networks devices are equipped with laser transmitters, which are considered a Class 1 Laser Product by the U.S. Food and Drug Administration and are evaluated as a Class 1 Laser Product per IEC/EN 60825-1 requirements.

Observe the following guidelines and warnings:

General Laser Safety Guidelines

When working around ports that support optical transceivers, observe the following safety guidelines to prevent eye injury:

- Do not look into unterminated ports or at fibers that connect to unknown sources.
- Do not examine unterminated optical ports with optical instruments.
- Avoid direct exposure to the beam.



LASER WARNING: Unterminated optical connectors can emit invisible laser radiation. The lens in the human eye focuses all the laser power on the retina, so focusing the eye directly on a laser source—even a low-power laser—could permanently damage the eye.

Avertissement Les connecteurs à fibre optique sans terminaison peuvent émettre un rayonnement laser invisible. Le cristallin de l'œil humain faisant converger toute la puissance du laser sur la rétine, toute focalisation directe de l'œil sur une source laser, —même de faible puissance—, peut entraîner des lésions oculaires irréversibles.

Class 1 Laser Product Warning



LASER WARNING: Class 1 laser product.

Waarschuwing Klasse-1 laser produkt.

Varoitus Luokan 1 lasertuote.

Avertissement Produit laser de classe I.

Warnung Laserprodukt der Klasse 1.

Avvertenza Prodotto laser di Classe 1.

Advarsel Laserprodukt av klasse 1.

Aviso Produto laser de classe 1.

¡Atención! Producto láser Clase I.

Varning! Laserprodukt av klass 1.

Class 1 LED Product Warning



LASER WARNING: Class 1 LED product.

Waarschuwing Klasse 1 LED-product.

Varoitus Luokan 1 valodiodituote.

Avertissement Alarme de produit LED Class I.

Warnung Class 1 LED-Produktwarnung.

Avvertenza Avvertenza prodotto LED di Classe 1.

Advarsel LED-produkt i klasse 1.

Aviso Produto de classe 1 com LED.

¡Atención! Aviso sobre producto LED de Clase 1.

Varning! Lysdiodprodukt av klass 1.

Laser Beam Warning



LASER WARNING: Do not stare into the laser beam or view it directly with optical instruments.

Waarschuwing Niet in de straal staren of hem rechtstreeks bekijken met optische instrumenten.

Varoitus Älä katso säteeseen äläkä tarkastele sitä suoraan optisen laitteen avulla.

Avertissement Ne pas fixer le faisceau des yeux, ni l'observer directement à l'aide d'instruments optiques.

Warnung Nicht direkt in den Strahl blicken und ihn nicht direkt mit optischen Geräten prüfen.

Avvertenza Non fissare il raggio con gli occhi né usare strumenti ottici per osservarlo direttamente.

Advarsel Stirr eller se ikke direkte p strlen med optiske instrumenter.

Aviso Não olhe fixamente para o raio, nem olhe para ele directamente com instrumentos ópticos.

¡Atención! No mirar fijamente el haz ni observarlo directamente con instrumentos ópticos.

Warning! Rikta inte blicken in mot strålen och titta inte direkt på den genom optiska instrument.

Radiation from Open Port Apertures Warning



LASER WARNING: Because invisible radiation might be emitted from the aperture of the port when no fiber cable is connected, avoid exposure to radiation and do not stare into open apertures.

Waarschuwing Aangezien onzichtbare straling vanuit de opening van de poort kan komen als er geen fiberkabel aangesloten is, dient blootstelling aan straling en het kijken in open openingen vermeden te worden.

Varoitus Koska portin aukosta voi emittoitua näkymätöntä säteilyä, kun kuitukaapelia ei ole kytkettyä, vältä säteilylle altistumista äläkä katso avoimiin aukkoihin.

Avertissement Des radiations invisibles à l'il nu pouvant traverser l'ouverture du port lorsqu'aucun câble en fibre optique n'y est connecté, il est recommandé de ne pas regarder fixement l'intérieur de ces ouvertures.

Warnung Aus der Port-Öffnung können unsichtbare Strahlen emittieren, wenn kein Glasfaserkabel angeschlossen ist. Vermeiden Sie es, sich den Strahlungen auszusetzen, und starren Sie nicht in die Öffnungen!

Avvertenza Quando i cavi in fibra non sono inseriti, radiazioni invisibili possono essere emesse attraverso l'apertura della porta. Evitate di esporvi alle radiazioni e non guardate direttamente nelle aperture.

Advarsel Unngå utsettelse for stråling, og stirr ikke inn i åpninger som er åpne, fordi usynlig stråling kan emitteres fra portens åpning når det ikke er tilkoblet en fiberkabel.

Aviso Dada a possibilidade de emissão de radiação invisível através do orifício da via de acesso, quando esta não tiver nenhum cabo de fibra conectado, deverá evitar a EXposição à radiação e não deverá olhar fixamente para orifícios que se encontrarem a descoberto.

¡Atención! Debido a que la apertura del puerto puede emitir radiación invisible cuando no existe un cable de fibra conectado, evite mirar directamente a las aperturas para no exponerse a la radiación.

Varning! Osynlig strålning kan avges från en portöppning utan ansluten fiberkabel och du bör därför undvika att bli utsatt för strålning genom att inte stirra in i oskyddade öppningar.

Maintenance and Operational Safety Guidelines and Warnings

IN THIS SECTION

- [Battery Handling Warning | 187](#)
- [Jewelry Removal Warning | 188](#)
- [Lightning Activity Warning | 189](#)
- [Operating Temperature Warning | 190](#)
- [Product Disposal Warning | 191](#)

While performing the maintenance activities for devices, observe the following guidelines and warnings:

Battery Handling Warning



WARNING: Replacing a battery incorrectly might result in an explosion. Replace a battery only with the same or equivalent type recommended by the manufacturer. Dispose of used batteries according to the manufacturer's instructions.

Waarschuwing Er is ontploffingsgevaar als de batterij verkeerd vervangen wordt. Vervang de batterij slechts met hetzelfde of een equivalent type dat door de fabrikant aanbevolen is. Gebruikte batterijen dienen overeenkomstig fabrieksvoorschriften weggegooid te worden.

Varoitus Räjähdyksen vaara, jos akku on vaihdettu väärään akkuun. Käytä vaihtamiseen ainoastaan saman- tai vastaavantyyppistä akkua, joka on valmistajan suosittama. Hävitä käytetyt akut valmistajan ohjeiden mukaan.

Avertissement Danger d'explosion si la pile n'est pas remplacée correctement. Ne la remplacer que par une pile de type semblable ou équivalent, recommandée par le fabricant. Jeter les piles usagées conformément aux instructions du fabricant.

Warnung Bei Einsetzen einer falschen Batterie besteht Explosionsgefahr. Ersetzen Sie die Batterie nur durch den gleichen oder vom Hersteller empfohlenen Batterietyp. Entsorgen Sie die benutzten Batterien nach den Anweisungen des Herstellers.

Advarsel Det kan være fare for eksplosjon hvis batteriet skiftes på feil måte. Skift kun med samme eller tilsvarende type som er anbefalt av produsenten. Kasser brukte batterier i henhold til produsentens instruksjoner.

Avvertenza Pericolo di esplosione se la batteria non è installata correttamente. Sostituire solo con una di tipo uguale o equivalente, consigliata dal produttore. Eliminare le batterie usate secondo le istruzioni del produttore.

Aviso Existe perigo de explosão se a bateria for substituída incorrectamente. Substitua a bateria por uma bateria igual ou de um tipo equivalente recomendado pelo fabricante. Destrua as baterias usadas conforme as instruções do fabricante.

¡Atención! Existe peligro de explosión si la batería se reemplaza de manera incorrecta. Reemplazar la batería EXclusivamente con el mismo tipo o el equivalente recomendado por el fabricante. Desechar las baterías gastadas según las instrucciones del fabricante.

Varning! Explosionsfara vid felaktigt batteribyte. Ersätt endast batteriet med samma batterityp som rekommenderas av tillverkaren eller motsvarande. Följ tillverkarens anvisningar vid kassering av använda batterier.

Jewelry Removal Warning



WARNING: Before working on equipment that is connected to power lines, remove jewelry, including rings, necklaces, and watches. Metal objects heat up when connected to power and ground and can cause serious burns or can be welded to the terminals.

Waarschuwing Alvorens aan apparatuur te werken die met elektrische leidingen is verbonden, sieraden (inclusief ringen, kettingen en horloges) verwijderen. Metalen voorwerpen worden warm wanneer ze met stroom en aarde zijn verbonden, en kunnen ernstige brandwonden veroorzaken of het metalen voorwerp aan de aansluitklemmen lassen.

Varoitus Ennen kuin työskentelet voimavirtajohtoihin kytkettyjen laitteiden parissa, ota pois kaikki korut (sormukset, kaulakorut ja kellot mukaan lukien). Metalliesineet kuumenevat, kun ne ovat yhteydessä sähkövirran ja maan kanssa, ja ne voivat aiheuttaa vakavia palovammoja tai hitsata metalliesineet kiinni liitäntänapoihin.

Avertissement Avant d'accéder à cet équipement connecté aux lignes électriques, ôter tout bijou (anneaux, colliers et montres compris). Lorsqu'ils sont branchés à l'alimentation et reliés à la terre, les objets métalliques chauffent, ce qui peut provoquer des blessures graves ou souder l'objet métallique aux bornes.

Warnung Vor der Arbeit an Geräten, die an das Netz angeschlossen sind, jeglichen Schmuck (einschließlich Ringe, Ketten und Uhren) abnehmen. Metallgegenstände erhitzen sich, wenn sie an das Netz und die Erde angeschlossen werden, und können schwere Verbrennungen verursachen oder an die Anschlußklemmen angeschweißt werden.

Avvertenza Prima di intervenire su apparecchiature collegate alle linee di alimentazione, togliersi qualsiasi monile (inclusi anelli, collane, braccialetti ed orologi). Gli oggetti metallici si riscaldano quando sono collegati tra punti di alimentazione e massa: possono causare ustioni gravi oppure il metallo può saldarsi ai terminali.

Advarsel Fjern alle smykker (inkludert ringe, halskjeder og klokker) før du skal arbeide på utstyr som er koblet til kraftledninger. Metallgjenstander som er koblet til kraftledninger og jord blir svært varme og kan forårsake alvorlige brannskader eller smelte fast til polene.

Aviso Antes de trabalhar em equipamento que esteja ligado a linhas de corrente, retire todas as jóias que estiver a usar (incluindo anéis, fios e relógios). Os objectos metálicos aquecerão em contacto com a corrente e em contacto com a ligação à terra, podendo causar queimaduras graves ou ficarem soldados aos terminais.

¡Atención! Antes de operar sobre equipos conectados a líneas de alimentación, quitarse las joyas (incluidos anillos, collares y relojes). Los objetos de metal se calientan cuando se conectan a la alimentación y a tierra, lo que puede ocasionar quemaduras graves o que los objetos metálicos queden soldados a los bornes.

Varning! Tag av alla smycken (inklusive ringar, halsband och armbandsur) innan du arbetar på utrustning som är kopplad till kraftledningar. Metallobjekt hettas upp när de kopplas ihop med ström och jord och kan förorsaka allvarliga brännskador; metallobjekt kan också sammansvetsas med kontakterna.

Lightning Activity Warning



WARNING: Do not work on the system or connect or disconnect cables during periods of lightning activity.

Waarschuwing Tijdens onweer dat gepaard gaat met bliksem, dient u niet aan het systeem te werken of kabels aan te sluiten of te ontkoppelen.

Varoitus Älä työskentele järjestelmän parissa äläkä yhdistä tai irrota kaapeleita ukkosilmalla.

Avertissement Ne pas travailler sur le système ni brancher ou débrancher les câbles pendant un orage.

Warnung Arbeiten Sie nicht am System und schließen Sie keine Kabel an bzw. trennen Sie keine ab, wenn es gewittert.

Avvertenza Non lavorare sul sistema o collegare oppure scollegare i cavi durante un temporale con fulmini.

Advarsel Utfør aldri arbeid på systemet, eller koble kabler til eller fra systemet når det tordner eller lyner.

Aviso Não trabalhe no sistema ou ligue e desligue cabos durante períodos de mau tempo (trovoada).

¡Atención! No operar el sistema ni conectar o desconectar cables durante el transcurso de descargas eléctricas en la atmósfera.

Varning! Vid åska skall du aldrig utföra arbete på systemet eller ansluta eller koppla loss kablar.

Operating Temperature Warning



WARNING: To prevent the device from overheating, do not operate it in an area that exceeds the maximum recommended ambient temperature. To prevent airflow restriction, allow at least 6 in. (15.2 cm) of clearance around the ventilation openings.

Waarschuwing Om te voorkomen dat welke switch van de Juniper Networks router dan ook oververhit raakt, dient u deze niet te bedienen op een plaats waar de maximale aanbevolen omgevingstemperatuur van 40° C wordt overschreden. Om te voorkomen dat de luchtstroom wordt beperkt, dient er minstens 15,2 cm speling rond de ventilatie-openingen te zijn.

Varoitus Ettei Juniper Networks switch-sarjan reititin ylikuumentuisi, sitä ei saa käyttää tilassa, jonka lämpötila ylittää korkeimman suositellun ympäristölämpötilan 40° C. Ettei ilmanvaihto estyisi, tuuletusaukkojen ympärille on jätettävä ainakin 15,2 cm tilaa.

Avertissement Pour éviter toute surchauffe des routeurs de la gamme Juniper Networks switch, ne l'utilisez pas dans une zone où la température ambiante est supérieure à 40° C. Pour permettre un flot d'air constant, dégagez un espace d'au moins 15,2 cm autour des ouvertures de ventilations.

Warnung Um einen Router der switch vor Überhitzung zu schützen, darf dieser nicht in einer Gegend betrieben werden, in der die Umgebungstemperatur das empfohlene Maximum von 40° C überschreitet. Um Lüftungsverschluß zu verhindern, achten Sie darauf, daß mindestens 15,2 cm lichter Raum um die Lüftungsöffnungen herum frei bleibt.

Avvertenza Per evitare il surriscaldamento dei switch, non adoperateli in un locale che ecceda la temperatura ambientale massima di 40° C. Per evitare che la circolazione dell'aria sia impedita, lasciate uno spazio di almeno 15.2 cm di fronte alle aperture delle ventole.

Advarsel Unngå overoppheting av eventuelle rutere i Juniper Networks switch Disse skal ikke brukes på steder der den anbefalte maksimale omgivelsestemperaturen overstiger 40° C (104° F). Sørg for at klaringen rundt lufteåpningene er minst 15,2 cm (6 tommer) for å forhindre nedsatt luftsirkulasjon.

Aviso Para evitar o sobreaquecimento do encaminhador Juniper Networks switch, não utilize este equipamento numa área que exceda a temperatura máxima recomendada de 40° C. Para evitar a restrição à circulação de ar, deixe pelo menos um espaço de 15,2 cm à volta das aberturas de ventilação.

¡Atención! Para impedir que un encaminador de la serie Juniper Networks switch se recaliente, no lo haga funcionar en un área en la que se supere la temperatura ambiente máxima recomendada de 40° C. Para impedir la restricción de la entrada de aire, deje un espacio mínimo de 15,2 cm alrededor de las aperturas para ventilación.

Warning! Förhindra att en Juniper Networks switch överhettas genom att inte använda den i ett område där den maximalt rekommenderade omgivningstemperaturen på 40° C överskrids. Förhindra att luftcirkulationen inskränks genom att se till att det finns fritt utrymme på minst 15,2 cm omkring ventilationsöppningarna.

Product Disposal Warning



WARNING: Disposal of this device must be handled according to all national laws and regulations.

Waarschuwing Dit produkt dient volgens alle landelijke wetten en voorschriften te worden afgedankt.

Varoitus Tämän tuotteen lopullisesta hävittämisestä tulee huolehtia kaikkia valtakunnallisia lakeja ja säännöksiä noudattaen.

Avertissement La mise au rebut définitive de ce produit doit être effectuée conformément à toutes les lois et réglementations en vigueur.

Warnung Dieses Produkt muß den geltenden Gesetzen und Vorschriften entsprechend entsorgt werden.

Avvertenza L'eliminazione finale di questo prodotto deve essere eseguita osservando le normative italiane vigenti in materia

Advarsel Endelig disponering av dette produktet må skje i henhold til nasjonale lover og forskrifter.

Aviso A descartagem final deste produto deverá ser efectuada de acordo com os regulamentos e a legislação nacional.

¡Atención! El desecho final de este producto debe realizarse según todas las leyes y regulaciones nacionales

Warning! Slutlig kassering av denna produkt bör skötas i enlighet med landets alla lagar och föreskrifter.

General Electrical Safety Guidelines and Warnings



WARNING: Certain ports on the device are designed for use as intrabuilding (within-the-building) interfaces only (Type 2 or Type 4 ports as described in *GR-1089-CORE*) and require isolation from the exposed outside plant (OSP) cabling. To comply with NEBS (Network Equipment-Building System) requirements and protect against lightning surges and commercial power disturbances, the intrabuilding ports *must not* be metallicly connected to interfaces that connect to the OSP or its wiring. The intrabuilding ports on the device are suitable for connection to intrabuilding or unexposed wiring or cabling only. The addition of primary protectors is not sufficient protection for connecting these interfaces metallicly to OSP wiring.

Avertissement Certains ports de l'appareil sont destinés à un usage en intérieur uniquement (ports Type 2 ou Type 4 tels que décrits dans le document *GR-1089-CORE*) et doivent être isolés du câblage de l'installation extérieure exposée. Pour respecter les exigences NEBS et assurer une protection contre la foudre et les perturbations de tension secteur, les ports pour intérieur *ne doivent pas* être raccordés physiquement aux interfaces prévues pour la connexion à l'installation extérieure ou à son câblage. Les ports pour intérieur de l'appareil sont réservés au raccordement de câbles pour intérieur ou non exposés uniquement. L'ajout de protections ne constitue pas une précaution suffisante pour raccorder physiquement ces interfaces au câblage de l'installation extérieure.



CAUTION: Before removing or installing components of a device, connect an electrostatic discharge (ESD) grounding strap to an ESD point and wrap and fasten the other end of the strap around your bare wrist. Failure to use an ESD grounding strap could result in damage to the device.

Attention Avant de retirer ou d'installer des composants d'un appareil, raccordez un bracelet antistatique à un point de décharge électrostatique et fixez le bracelet à votre poignet nu. L'absence de port d'un bracelet antistatique pourrait provoquer des dégâts sur l'appareil.

- Install the device in compliance with the following local, national, and international electrical codes:
 - United States—National Fire Protection Association (NFPA 70), United States National Electrical Code.
 - Other countries—International Electromechanical Commission (IEC) 60364, Part 1 through Part 7.
 - Evaluated to the TN power system.

- Canada—Canadian Electrical Code, Part 1, CSA C22.1.
- Suitable for installation in Information Technology Rooms in accordance with Article 645 of the National Electrical Code and NFPA 75.

Peut être installé dans des salles de matériel de traitement de l'information conformément à l'article 645 du National Electrical Code et à la NFPA 75.

- Locate the emergency power-off switch for the room in which you are working so that if an electrical accident occurs, you can quickly turn off the power.
- Make sure that you clean grounding surface and give them a bright finish before making grounding connections.
- Do not work alone if potentially hazardous conditions exist anywhere in your workspace.
- Never assume that power is disconnected from a circuit. Always check the circuit before starting to work.
- Carefully look for possible hazards in your work area, such as moist floors, ungrounded power extension cords, and missing safety grounds.
- Operate the device within marked electrical ratings and product usage instructions.
- To ensure that the device and peripheral equipment function safely and correctly, use the cables and connectors specified for the attached peripheral equipment, and make certain they are in good condition.

You can remove and replace many device components without powering off or disconnecting power to the device, as detailed elsewhere in the hardware documentation for this device. Never install equipment that appears to be damaged.

Prevention of Electrostatic Discharge Damage

Device components that are shipped in antistatic bags are sensitive to damage from static electricity. Some components can be impaired by voltages as low as 30 V. You can easily generate potentially damaging static voltages whenever you handle plastic or foam packing material or if you move components across plastic or carpets. Observe the following guidelines to minimize the potential for electrostatic discharge (ESD) damage, which can cause intermittent or complete component failures:

- Always use an ESD wrist strap when you are handling components that are subject to ESD damage, and make sure that it is in direct contact with your skin.

If a grounding strap is not available, hold the component in its antistatic bag (see [Figure 66 on page 194](#)) in one hand and touch the exposed, bare metal of the device with the other hand immediately before inserting the component into the device.



WARNING: For safety, periodically check the resistance value of the ESD grounding strap. The measurement must be in the range 1 through 10 Mohms.

Avertissement Par mesure de sécurité, vérifiez régulièrement la résistance du bracelet antistatique. Cette valeur doit être comprise entre 1 et 10 mégohms (Mohms).

- When handling any component that is subject to ESD damage and that is removed from the device, make sure the equipment end of your ESD wrist strap is attached to the ESD point on the chassis.

If no grounding strap is available, touch the exposed, bare metal of the device to ground yourself before handling the component.

- Avoid contact between the component that is subject to ESD damage and your clothing. ESD voltages emitted from clothing can damage components.
- When removing or installing a component that is subject to ESD damage, always place it component-side up on an antistatic surface, in an antistatic card rack, or in an antistatic bag (see [Figure 66 on page 194](#)). If you are returning a component, place it in an antistatic bag before packing it.

Figure 66: Placing a Component into an Antistatic Bag

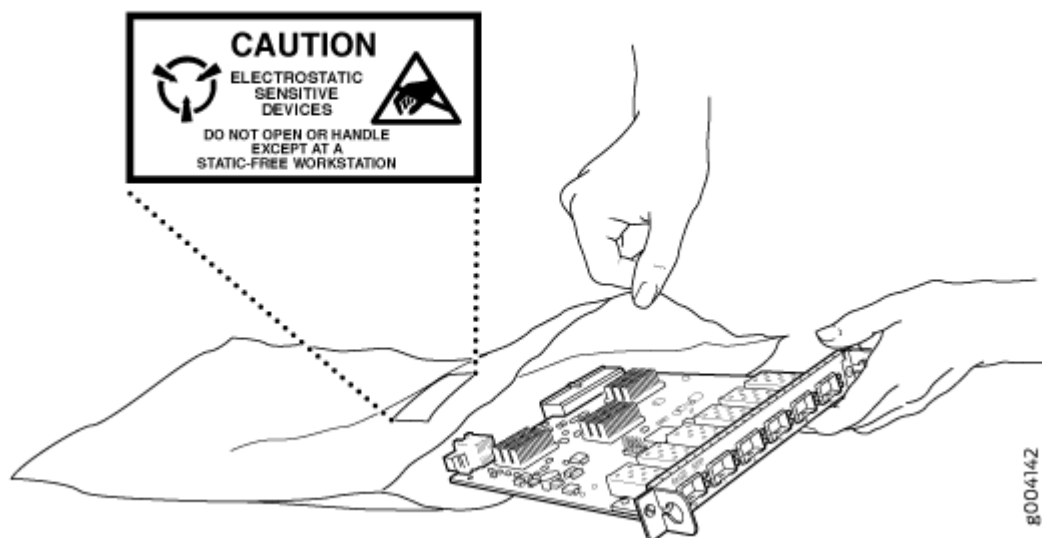



CAUTION: ANSI/TIA/EIA-568 cables such as Category 5e and Category 6 can get electrostatically charged. To dissipate this charge, always ground the cables to a suitable and safe earth ground before connecting them to the system.

Attention Les câbles ANSI/TIA/EIA-568, par exemple Cat 5e et Cat 6, peuvent emmagasiner des charges électrostatiques. Pour évacuer ces charges, reliez toujours les câbles à une prise de terre adaptée avant de les raccorder au système.

Site Electrical Wiring Guidelines

Table 38 on page 195 describes the factors you must consider while planning the electrical wiring at your site.



WARNING: You must provide a properly grounded and shielded environment and use electrical surge-suppression devices.

Avertissement Vous devez établir un environnement protégé et convenablement mis à la terre et utiliser des dispositifs de parasurtension.

Table 38: Site Electrical Wiring Guidelines

Site Wiring Factor	Guidelines
Signaling limitations	<p>If your site experiences any of the following problems, consult experts in electrical surge suppression and shielding:</p> <ul style="list-style-type: none"> • Radio frequency interference (RFI) because of improperly installed wires • Damage from lightning strikes occurring when wires exceed recommended distances or pass between buildings • Electromagnetic pulses (EMPs) caused by lightning damaging unshielded conductors and electronic devices

Table 38: Site Electrical Wiring Guidelines (Continued)

Site Wiring Factor	Guidelines
Radio frequency interference	<p>To reduce or eliminate RFI from your site wiring, do the following:</p> <ul style="list-style-type: none"> • Use a twisted-pair cable with a good distribution of grounding conductors. • To exceed the recommended distances, use a high-quality twisted-pair cable with one ground conductor for each data signal, when applicable.
Electromagnetic compatibility	<p>If your site is susceptible to problems with electromagnetic compatibility (EMC), particularly from lightning or radio transmitters, seek expert advice.</p> <p>Strong sources of electromagnetic interference (EMI) can cause:</p> <ul style="list-style-type: none"> • Destruction of the signal drivers and receivers in the device. • Electrical hazards as a result of power surges conducted over the lines into the equipment.

AC Power Electrical Safety Guidelines

The following electrical safety guidelines apply to AC-powered devices:

- Note the following warnings printed on the device:

“CAUTION: THIS UNIT HAS MORE THAN ONE POWER SUPPLY CORD. DISCONNECT ALL POWER SUPPLY CORDS BEFORE SERVICING TO AVOID ELECTRIC SHOCK.”

“ATTENTION: CET APPAREIL COMPORTE PLUS D'UN CORDON D'ALIMENTATION. AFIN DE PRÉVENIR LES CHOCS ÉLECTRIQUES, DÉBRANCHER TOUT CORDON D'ALIMENTATION AVANT DE FAIRE LE DÉPANNAGE.”

- AC-powered devices are shipped with a three-wire electrical cord with a grounding-type plug that fits only a grounding-type power outlet. Do not circumvent this safety feature. Equipment grounding must comply with local and national electrical codes.
- You must provide an external certified circuit breaker (2-pole circuit breaker or 4-pole circuit breaker based on your device) rated minimum 20 A in the building installation.

- The power cord serves as the main disconnecting device for the AC-powered device. The socket outlet must be near the AC-powered device and be easily accessible.
- For devices that have more than one power supply connection, you must ensure that all power connections are fully disconnected so that power to the device is completely removed to prevent electric shock. To disconnect power, unplug all power cords (one for each power supply).

Power Cable Warning (Japanese)

WARNING: The attached power cable is only for this product. Do not use the cable for another product.

注意

附属の電源コードセットはこの製品専用です。
他の電気機器には使用しないでください。

9477283

AC Power Disconnection Warning



WARNING: Before working on the device or near power supplies, unplug all the power cords from an AC-powered device.

Waarschuwing Voordat u aan een frame of in de nabijheid van voedingen werkt, dient u bij wisselstroom toestellen de stekker van het netsnoer uit het stopcontact te halen.

Varoitus Kytke irti vaihtovirtalaitteiden virtajohto, ennen kuin teet mitään asennuspohjalle tai työskentelet virtalähteiden läheisyydessä.

Avertissement Avant de travailler sur un châssis ou à proximité d'une alimentation électrique, débrancher le cordon d'alimentation des unités en courant alternatif.

Warnung Bevor Sie an einem Chassis oder in der Nähe von Netzgeräten arbeiten, ziehen Sie bei Wechselstromeinheiten das Netzkabel ab bzw.

Avvertenza Prima di lavorare su un telaio o intorno ad alimentatori, scollegare il cavo di alimentazione sulle unità CA.

Advarsel Før det utføres arbeid på kabinettet eller det arbeides i nærheten av strømforsyningsenheter, skal strømledningen trekkes ut på vekselstrømsenheter.

Aviso Antes de trabalhar num chassis, ou antes de trabalhar perto de unidades de fornecimento de energia, desligue o cabo de alimentação nas unidades de corrente alternada.

¡Atención! Antes de manipular el chasis de un equipo o trabajar cerca de una fuente de alimentación, desenchufar el cable de alimentación en los equipos de corriente alterna (CA).

Warning! Innan du arbetar med ett chassi eller nära strömförsörjningsenheter skall du för växelströmsenheter dra ur nätsladden.

DC Power Disconnection Warning



WARNING: Before performing any of the DC power procedures, ensure that power is removed from the DC circuit. To ensure that all power is off, locate the circuit breaker on the panel board that services the DC circuit, switch the circuit breaker to the OFF position, and tape the device handle of the circuit breaker in the OFF position.

Waarschuwing Voordat u een van de onderstaande procedures uitvoert, dient u te controleren of de stroom naar het gelijkstroom circuit uitgeschakeld is. Om u ervan te verzekeren dat alle stroom UIT is geschakeld, kiest u op het schakelbord de stroomverbreker die het gelijkstroom circuit bedient, draait de stroomverbreker naar de UIT positie en plakt de schakelaarhendel van de stroomverbreker met plakband in de UIT positie vast.

Varoitus Varmista, että tasavirtapiirissä ei ole virtaa ennen seuraavien toimenpiteiden suorittamista. Varmistaaksesi, että virta on KATKAISTU täysin, paikanna tasavirrasta huolehtivassa kojetaulussa sijaitseva suojakytkin, käännä suojakytkin KATKAISTU-asentoon ja teippaa suojakytkimen varsi niin, että se pysyy KATKAISTU-asennossa.

Avertissement Avant de pratiquer l'une quelconque des procédures ci-dessous, vérifier que le circuit en courant continu n'est plus sous tension. Pour en être sûr, localiser le disjoncteur situé sur le panneau de service du circuit en courant continu, placer le disjoncteur en position fermée (OFF) et, à l'aide d'un ruban adhésif, bloquer la poignée du disjoncteur en position OFF.

Warnung Vor Ausführung der folgenden Vorgänge ist sicherzustellen, daß die Gleichstromschaltung keinen Strom erhält. Um sicherzustellen, daß sämtlicher Strom abgestellt ist, machen Sie auf der Schalttafel den Unterbrecher für die

Gleichstromschaltung ausfindig, stellen Sie den Unterbrecher auf AUS, und kleben Sie den Schaltergriff des Unterbrechers mit Klebeband in der AUS-Stellung fest.

Avvertenza Prima di svolgere una qualsiasi delle procedure seguenti, verificare che il circuito CC non sia alimentato. Per verificare che tutta l'alimentazione sia scollegata (OFF), individuare l'interruttore automatico sul quadro strumenti che alimenta il circuito CC, mettere l'interruttore in posizione OFF e fissarlo con nastro adesivo in tale posizione.

Advarsel Før noen av disse prosedyrene utføres, kontroller at strømmen er frakoblet likestrømkretsen. Sørg for at all strøm er slått AV. Dette gjøres ved å lokalisere strømbryteren på brytertavlen som betjener likestrømkretsen, slå strømbryteren AV og teipe bryterhåndtaket på strømbryteren i AV-stilling.

Aviso Antes de executar um dos seguintes procedimentos, certifique-se que desligou a fonte de alimentação de energia do circuito de corrente contínua. Para se assegurar que toda a corrente foi DESLIGADA, localize o disjuntor no painel que serve o circuito de corrente contínua e coloque-o na posição OFF (Desligado), segurando nessa posição a manivela do interruptor do disjuntor com fita isoladora.

¡Atención! Antes de proceder con los siguientes pasos, comprobar que la alimentación del circuito de corriente continua (CC) esté cortada (OFF). Para asegurarse de que toda la alimentación esté cortada (OFF), localizar el interruptor automático en el panel que alimenta al circuito de corriente continua, cambiar el interruptor automático a la posición de Apagado (OFF), y sujetar con cinta la palanca del interruptor automático en posición de Apagado (OFF).

Warning! Innan du utför någon av följande procedurer måste du kontrollera att strömförsörjningen till likströmskretsen är bruten. Kontrollera att all strömförsörjning är BRUTEN genom att slå AV det överspänningsskydd som skyddar likströmskretsen och tejpa fast överspänningsskyddets omkopplare i FRÅN-läget.

DC Power Grounding Requirements and Warning

An insulated grounding conductor that is identical in size to the grounded and ungrounded branch circuit supply conductors but is identifiable by green and yellow stripes is installed as part of the branch circuit that supplies the device. The grounding conductor is a separately derived system at the supply transformer or motor generator set.



WARNING: When you install the device, the ground connection must always be made first and disconnected last.

Waarschuwing Bij de installatie van het toestel moet de aardverbinding altijd het eerste worden gemaakt en het laatste worden losgemaakt.

Varoitus Laitetta asennettaessa on maahan yhdistäminen aina tehtävä ensiksi ja maadoituksen irti kytkeminen viimeiseksi.

Avertissement Lors de l'installation de l'appareil, la mise à la terre doit toujours être connectée en premier et déconnectée en dernier.

Warnung Der Erdanschluß muß bei der Installation der Einheit immer zuerst hergestellt und zuletzt abgetrennt werden.

Avvertenza In fase di installazione dell'unità, eseguire sempre per primo il collegamento a massa e disconnetterlo per ultimo.

Advarsel Når enheten installeres, må jordledningen alltid tilkobles først og frakobles sist.

Aviso Ao instalar a unidade, a ligação à terra deverá ser sempre a primeira a ser ligada, e a última a ser desligada.

¡Atención! Al instalar el equipo, conectar la tierra la primera y desconectarla la última.

Warning! Vid installation av enheten måste jordledningen alltid anslutas först och kopplas bort sist.

DC Power Wiring Sequence Warning



WARNING: Wire the DC power supply using the appropriate lugs. When connecting power, the proper wiring sequence is ground to ground, +RTN to +RTN, then -48 V to -48 V. When disconnecting power, the proper wiring sequence is -48 V to -48 V, +RTN to +RTN, then ground to ground. Note that the ground wire must always be connected first and disconnected last.

Waarschuwing De juiste bedradingsvolgorde verbonden is aarde naar aarde, +RTN naar +RTN, en -48 V naar -48 V. De juiste bedradingsvolgorde losgemaakt is en -48 naar -48 V, +RTN naar +RTN, aarde naar aarde.

Varoitus Oikea yhdistettävä kytkentäjärjestys on maajohto maajohtoon, +RTN varten +RTN, -48 V varten - 48 V. Oikea irrotettava kytkentäjärjestys on -48 V varten - 48 V, +RTN varten +RTN, maajohto maajohtoon.

Avertissement Câblez l'alimentation d'alimentation CC En utilisant les crochets appropriés à l'extrémité de câblage. En reliant la puissance, l'ordre approprié de câblage est rectifié pour rectifier, +RTN à +RTN, puis -48 V à -48 V. En débranchant la puissance, l'ordre approprié de câblage est -48 V à -48 V, +RTN à +RTN, a alors rectifié pour rectifier. Notez que le fil de masse devrait toujours être relié d'abord et débranché pour la dernière fois. Notez que le fil de masse devrait toujours être relié d'abord et débranché pour la dernière fois.

Warnung Die Stromzufuhr ist nur mit geeigneten Ringösen an das DC Netzteil anzuschliessen. Die richtige Anschlusssequenz ist: Erdanschluss zu Erdanschluss, +RTN zu +RTN und dann -48V zu -48V. Die richtige Sequenz zum Abtrennen der Stromversorgung ist -48V zu -48V, +RTN zu +RTN und dann Erdanschluss zu Erdanschluss. Es ist zu beachten dass der Erdanschluss immer zuerst angeschlossen und als letztes abgetrennt wird.

Avvertenza Mostra la morsettiera dell'alimentatore CC. Cablare l'alimentatore CC usando i connettori adatti all'estremità del cablaggio, come illustrato. La corretta sequenza di cablaggio è da massa a massa, da positivo a positivo (da linea ad L) e da negativo a negativo (da neutro a N). Tenere presente che il filo di massa deve sempre venire collegato per primo e scollegato per ultimo.

Advarsel Riktig tilkoples tilkoplingssekvens er jord til jord, +RTN til +RTN, -48 V til -48 V. Riktig frakoples tilkoplingssekvens er -48 V til -48 V, +RTN til +RTN, jord til jord.

Aviso Ate con alambre la fuente de potencia cc Usando los terminales apropiados en el extremo del cableado. Al conectar potencia, la secuencia apropiada del cableado se muele para moler, +RTN a +RTN, entonces -48 V a -48 V. Al desconectar potencia, la secuencia apropiada del cableado es -48 V a -48 V, +RTN a +RTN, entonces molió para moler. Observe que el alambre de tierra se debe conectar siempre primero y desconectar por último. Observe que el alambre de tierra se debe conectar siempre primero y desconectar por último.

¡Atención! Wire a fonte de alimentação de DC Usando os talões apropriados nan Extremidade da fiação. Ao conectar a potência, a seqüência apropriada da fiação é moída para moer, +RTN a +RTN, então -48 V a -48 V. Ao desconectar a potência, a seqüência apropriada da fiação é -48 V a -48 V, +RTN a +RTN, moeu então para moer. Anote que o fio à terra deve sempre ser conectado primeiramente e desconectado por último. Anote que o fio à terra deve sempre ser conectado primeiramente e desconectado por último.

Warning! Korrekt kopplingssekvens ar jord till jord, +RTN till +RTN, -48 V till -48 V.
Korrekt kopplas kopplingssekvens ar -48 V till -48 V, +RTN till +RTN, jord till jord.

DC Power Wiring Terminations Warning



WARNING: When stranded wiring is required, use approved wiring terminations, such as closed-loop or spade-type with upturned lugs. These terminations must be the appropriate size for the wires and must clamp both the insulation and conductor.

Waarschuwing Wanneer geslagen bedrading vereist is, dient u bedrading te gebruiken die voorzien is van goedgekeurde aansluitpunten, zoals het gesloten-lus type of het grijperschop type waarbij de aansluitpunten omhoog wijzen. Deze aansluitpunten dienen de juiste maat voor de draden te hebben en dienen zowel de isolatie als de geleider vast te klemmen.

Varoitus Jos säikeellinen johdin on tarpeen, käytä hyväksyttyä johdinliitääntä, esimerkiksi suljettua silmukkaa tai kourumaista liitääntä, jossa on ylöspäin käännetyt kiinnityskorvat. Tällaisten liitääntöjen tulee olla kooltaan johtimiin sopivia ja niiden tulee puristaa yhteen sekä eristeen että johdinosan.

Avertissement Quand des fils torsadés sont nécessaires, utiliser des douilles terminales homologuées telles que celles à circuit fermé ou du type à plage ouverte avec cosses rebroussées. Ces douilles terminales doivent être de la taille qui convient aux fils et doivent être refermées sur la gaine isolante et sur le conducteur.

Warnung Wenn Litzenverdrahtung erforderlich ist, sind zugelassene Verdrahtungsabschlüsse, z.B. für einen geschlossenen Regelkreis oder gabelförmig, mit nach oben gerichteten Kabelschuhen zu verwenden. Diese Abschlüsse sollten die angemessene Größe für die Drähte haben und sowohl die Isolierung als auch den Leiter festklemmen.

Avvertenza Quando occorre usare trecce, usare connettori omologati, come quelli a occhio o a forcella con linguette rivolte verso l'alto. I connettori devono avere la misura adatta per il cablaggio e devono serrare sia l'isolante che il conduttore.

Advarsel Hvis det er nødvendig med flertrådede ledninger, brukes godkjente ledningsavslutninger, som for eksempel lukket sløyfe eller spadetype med oppoverbøyde kabelsko. Disse avslutningene skal ha riktig størrelse i forhold til ledningene, og skal klemme sammen både isolasjonen og ledningen.

Aviso Quando forem requeridas montagens de instalação eléctrica de cabo torcido, use terminações de cabo aprovadas, tais como, terminações de cabo em circuito fechado e planas com terminais de orelha voltados para cima. Estas terminações de cabo deverão ser do tamanho apropriado para os respectivos cabos, e deverão prender simultaneamente o isolamento e o fio condutor.

¡Atención! Cuando se necesite hilo trenzado, utilizar terminales para cables homologados, tales como las de tipo "bucle cerrado" o "espada", con las lengüetas de conexión vueltas hacia arriba. Estos terminales deberán ser del tamaño apropiado para los cables que se utilicen, y tendrán que sujetar tanto el aislante como el conductor.

Warning! När flertrådiga ledningar krävs måste godkända ledningskontakter användas, t.ex. kabelsko av slutet eller öppen typ med uppåtvänd tapp. Storleken på dessa kontakter måste vara avpassad till ledningarna och måste kunna hålla både isoleringen och ledaren fastklämda.

Multiple Power Supplies Disconnection Warning



WARNING: The network device has more than one power supply connection. All connections must be removed completely to remove power from the unit completely.

Waarschuwing Deze eenheid heeft meer dan één stroomtoevoerverbinding; alle verbindingen moeten volledig worden verwijderd om de stroom van deze eenheid volledig te verwijderen.

Varoitus Tässä laitteessa on useampia virtalähdekytkentöjä. Kaikki kytkennät on irrotettava kokonaan, jotta virta poistettaisiin täysin laitteesta.

Avertissement Cette unité est équipée de plusieurs raccordements d'alimentation. Pour supprimer tout courant électrique de l'unité, tous les cordons d'alimentation doivent être débranchés.

Warnung Diese Einheit verfügt über mehr als einen Stromanschluß; um Strom gänzlich von der Einheit fernzuhalten, müssen alle Stromzufuhren abgetrennt sein.

Avvertenza Questa unità ha più di una connessione per alimentatore elettrico; tutte le connessioni devono essere completamente rimosse per togliere l'elettricità dall'unità.

Advarsel Denne enheten har mer enn én strømtilkobling. Alle tilkoblinger må kobles helt fra for å eliminere strøm fra enheten.

Aviso Este dispositivo possui mais do que uma conexão de fonte de alimentação de energia; para poder remover a fonte de alimentação de energia, deverão ser desconectadas todas as conexões existentes.

¡Atención! Esta unidad tiene más de una conexión de suministros de alimentación; para eliminar la alimentación por completo, deben desconectarse completamente todas las conexiones.

Varning! Denna enhet har mer än en strömförsörjningsanslutning; alla anslutningar måste vara helt avlägsnade innan strömtillförseln till enheten är fullständigt bruten.

TN Power Warning



WARNING: The device is designed to work with a TN power system.

Waarschuwing Het apparaat is ontworpen om te functioneren met TN energiesystemen.

Varoitus Koje on suunniteltu toimimaan TN-sähkövoimajärjestelmien yhteydessä.

Avertissement Ce dispositif a été conçu pour fonctionner avec des systèmes d'alimentation TN.

Warnung Das Gerät ist für die Verwendung mit TN-Stromsystemen ausgelegt.

Avvertenza Il dispositivo è stato progettato per l'uso con sistemi di alimentazione TN.

Advarsel Utstyret er utfomet til bruk med TN-strømssystemer.

Aviso O dispositivo foi criado para operar com sistemas de corrente TN.

¡Atención! El equipo está diseñado para trabajar con sistemas de alimentación tipo TN.

Varning! Enheten är konstruerad för användning tillsammans med elkraftssystem av TN-typ.

Action to Take After an Electrical Accident

If an electrical accident results in an injury, take the following actions in this order:

1. Use caution. Be aware of potentially hazardous conditions that could cause further injury.
2. Disconnect power from the device.
3. If possible, send another person to get medical aid. Otherwise, assess the condition of the victim, and then call for help.

Agency Approvals for MX10003 Router

IN THIS SECTION

- [Compliance Statement for Argentina | 207](#)

The router comply with the following standards:

- Safety
 - CAN/CSA-22.2 No. 60950-00/UL 1950 Third Edition, Safety of Information Technology Equipment
 - UL 60950-1 Information Technology Equipment - Safety - Part 1: General Requirements
 - EN 60950-1 European Norm, Safety of Information Technology Equipment
 - IEC 60950-1 Information Technology Equipment - Safety - Part 1: General Requirements (with country deviations)
 - EN 60825-1 Safety of Laser Products - Part 1: Equipment Classification, Requirements and User's Guide
- EMC
 - EN 300 386 V2.1.1 Telecom Network Equipment - EMC Requirements
 - KN35 Korea Immunity Characteristics
 - EN 55024 Information Technology Equipment Immunity Characteristics
 - CISPR 24:2010 IT Equipment Immunity Characteristics
- EMI

- FCC Part 15 Class A USA Radiated Emissions
- EN 55022 Class A European Radiated Emissions
- CISPR 22 Class A European Radiated Emissions
- EN 55032:Electromagnetic compatibility of multimedia equipment - Emission requirements
- CISPR 32 Electromagnetic compatibility of multimedia equipment - Emission requirements
- VCCI Class A Japanese Radiated Emissions
- BSMI CNS 13438 Taiwan Radiated Emissions (at 10 Meter)
- KN32/KN35 Korea Radiated Emission and Immunity Characteristics (at 10 Meter)
- AS/NZS CISPR32 Australia/New Zealand Radiated Emissions
- ICES-003 Canada Radiated Emissions
- Immunity
 - EN-61000-3-2 Power Line Harmonics
 - EN-61000-3-3 Voltage Fluctuations and Flicker
 - EN-61000-4-2 ESD
 - EN-61000-4-3 Radiated Immunity
 - EN-61000-4-4 EFT
 - EN-61000-4-5 Surge
 - EN-61000-4-6 Conducted Disturbances Immunity
 - EN-61000-4-11 Voltage Dips and Sags

The router is designed to comply with the following standards:

- GR-63-Core: NEBS, Physical Protection
- GR-1089-Core:EMC and Electrical Safety for Network Telecommunications Equipment
- SR-3580 NEBS Criteria Levels (Level 3 Compliance)

Compliance Statement for Argentina

EQUIPO DE USO IDÓNEO.

Compliance Statements for Data Center

- The equipment is suitable for installation as part of the Common Bonding Network (CBN).
- The equipment is suitable for installation in locations where the National Electrical Code (NEC) applies.
- The battery return connection is to be treated as an isolated DC return (that is, DC-I), as defined in GR-1089-CORE.
- You must provision a readily accessible device outside of the equipment to disconnect power. The device must also be rated based on local electrical code practice.

Compliance Statements for EMC Requirements

IN THIS SECTION

- [Canada | 207](#)
- [European Community | 208](#)
- [Israel | 208](#)
- [Japan | 208](#)
- [United States | 208](#)

Canada

CAN ICES-3 (A)/NMB-3(A)

European Community

This is a Class A product. In a domestic environment, this product might cause radio interference in which case the user might be required to take adequate measures.

Israel

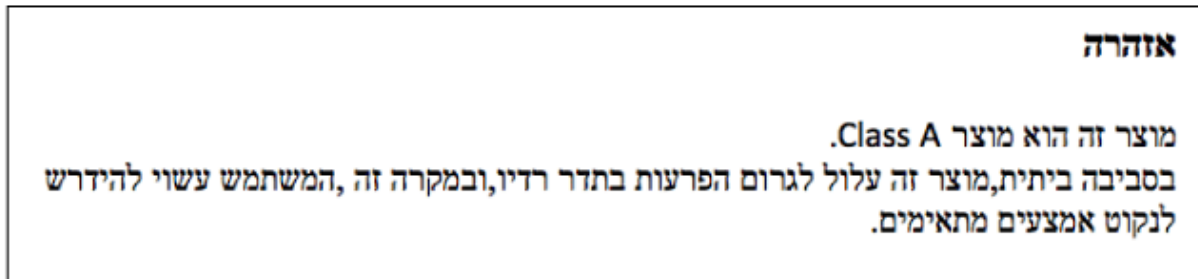

Translation from Hebrew—Warning: This product is Class A. In residential environments, the product might cause radio interference, and in such a situation, the user might be required to take adequate measures.

Japan

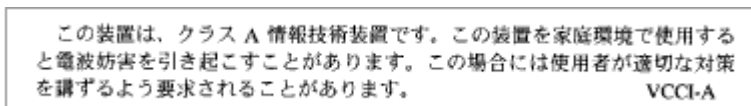

The preceding translates as follows:

This is a Class A product based on the standard of the Voluntary Control Council for Interference by Information Technology Equipment (VCCI). If this product is used near a radio or television receiver in a domestic environment, it might cause radio interference. Install and use the equipment according to the instruction manual. VCCI-A.

United States

The hardware equipment has been tested and found to comply with the limits for a Class A digital device, pursuant to Part 15 of the FCC Rules. These limits are designed to provide reasonable protection

against harmful interference when the equipment is operated in a commercial environment. This equipment generates, uses, and can radiate radio frequency energy and, if not installed and used in accordance with the instruction manual, might cause harmful interference to radio communications. Operation of this equipment in a residential area is likely to cause harmful interference in which case the user will be required to correct the interference at his own expense.

Compliance Statements for Environmental Requirements

Batteries in this product are not based on mercury, lead, or cadmium substances. The batteries used in this product are in compliance with EU Directives 91/157/EEC, 93/86/EEC, and 98/101/EEC. The product documentation includes instructional information about the proper method of reclamation and recycling.

Compliance Statements for Acoustic Noise for MX10003 Router

The router complies with NEBS Level 3 requirements:

- GR-63-CORE: NEBS, Physical Protection
- GR-1089-CORE: EMC and Electrical Safety for Network Telecommunications Equipment

Statements of Volatility for Juniper Network Devices

A *statement of volatility (SoV)*—sometimes known as *letter of volatility (LoV)*—identifies the volatile and non-volatile storage components in Juniper Networks devices, and describes how to remove non-volatile storage components from the device.

NOTE: Individual FRUs do not have separate SoV or LoV documents. They are covered in the SoV or LoV of the Juniper Networks device in which they are installed.

NOTE: Statements of volatility are not available for all Juniper Networks devices.

CTP Series:

- [CTP150](#)
- [CTP2000](#)

EX Series:

- [EX2200](#) and [EX2200-C](#)
- [EX2300-24P](#), [EX2300-24T](#), and [EX2300-24T-DC](#)
- [EX2300-48P](#) and [EX2300-48T](#)
- [EX2300-C](#)
- [EX3300](#)
- [EX3400-24P](#), [EX3400-24T](#), [EX3400-24T-DC](#)
- [EX3400-48P](#), [EX3400-48T](#), [EX3400-48T-AFI](#)
- [EX4200](#)
- [EX4300](#)
- [EX4300-48MP](#)
- [EX4400](#)
 1. [EX4400-24T](#)
 2. [EX4400-24P](#)
 3. [EX4400-24MP](#)
 4. [EX4400-48T](#)
 5. [EX4400-48P](#)

6. EX4400-48MP

7. EX4400-48F

- EX4500
- EX4550
- EX4600
- EX8200
- EX9251
- EX9253
- XRE200 External Routing Engine

LN Series:

- LN1000-CC

MX Series:

- M7i
- M7i Compact Forwarding Engine Board (CFEB)
- M40e and M10i
- M320
- MX5, MX10, MX40, and MX80
- MX104
- MX204
- MX304
- MX240, MX480, and MX960
- MX10003
- RE-A-2000 Route Engine
- RE-S-X6-64G Routing Engine

NFX Series:

- NFX250

QFX Series:

- [QFX3008-I](#)
- [QFX3100](#)
- [QFX3500](#)
- [QFX3600](#)
- [QFX5100-24Q](#)
- [QFX5100-48S](#)
- [QFX5100-48T](#)
- [QFX5110-32Q](#)
- [QFX5110-48S](#)
- [QFX5120](#)
 1. [QFX5120-32C](#)
 2. [QFX5120-48T](#)
 3. [QFX5120-48Y](#)
 4. [QFX5120-48YM](#)
- [QFX5200](#)
- [QFX5200-32C](#)
- [QFX10008](#) and [QFX10016](#)

SRX Series:

- [SRX100](#)
- [SRX110](#)
- [SRX210B](#)
- [SRX210H-POE](#)
- [SRX210H-P-MGW](#)
- [SRX220](#)
- [SRX240H](#)

- [SRX240H-POE](#)
- [SRX300](#)
- [SRX320](#)
- [SRX340 and SRX345](#)
- [SRX380](#)
- [SRX550](#)
- [SRX650](#)
- [SRX1400](#)
- [SRX1500](#)
- [SRX3400 and SRX3600](#)
- [SRX4200](#)
- [SRX4600](#)
- [SRX5400, SRX5600, and SRX5800](#)
- [SRX-MP-1SERIAL](#)
- [SSG-520M](#)

T Series:

- [RE-A-2000 Route Engine](#)