

PTX10008 Packet Transport Router Hardware Guide

Published
2024-08-22

Juniper Networks, Inc.
1133 Innovation Way
Sunnyvale, California 94089
USA
408-745-2000
www.juniper.net

Juniper Networks, the Juniper Networks logo, Juniper, and Junos are registered trademarks of Juniper Networks, Inc. in the United States and other countries. All other trademarks, service marks, registered marks, or registered service marks are the property of their respective owners.

Juniper Networks assumes no responsibility for any inaccuracies in this document. Juniper Networks reserves the right to change, modify, transfer, or otherwise revise this publication without notice.

PTX10008 Packet Transport Router Hardware Guide
Copyright © 2024 Juniper Networks, Inc. All rights reserved.

The information in this document is current as of the date on the title page.

YEAR 2000 NOTICE

Juniper Networks hardware and software products are Year 2000 compliant. Junos OS has no known time-related limitations through the year 2038. However, the NTP application is known to have some difficulty in the year 2036.

END USER LICENSE AGREEMENT

The Juniper Networks product that is the subject of this technical documentation consists of (or is intended for use with) Juniper Networks software. Use of such software is subject to the terms and conditions of the End User License Agreement ("EULA") posted at <https://support.juniper.net/support/eula/>. By downloading, installing or using such software, you agree to the terms and conditions of that EULA.

Table of Contents

About This Guide | xii

1

Fast Track: Initial Installation

Fast Track to Rack Installation and Power | 2

Install the PTX10008 in a Rack | 2

Connect to Power | 7

Onboard, Configure, and Monitor the PTX10008 | 12

2

Overview

PTX10008 System Overview | 15

PTX10008 Hardware Overview | 15

PTX10008 Configurations and Upgrade Options | 31

PTX10008 Component Redundancy | 40

PTX10008 Hardware and CLI Terminology Mapping | 41

PTX10008 Chassis | 44

PTX10008 Chassis Physical Specifications | 45

PTX10008 Field-Replaceable Units | 49

PTX10008 Status Panel | 51

PTX10008 Optional Equipment | 55

PTX10008 Cooling System | 57

PTX10008 Cooling System and Airflow | 58

PTX10008 Fan Tray LEDs and Fan Tray Controller LEDs | 68

PTX10008 Power System | 75

JNP10K-PWR-AC Power Supply | 76

JNP10K-PWR-AC2 Power Supply | 78

JNP10K-PWR-AC3 Power Supply | 81

- JNP10K-PWR-DC Power Supply | 86
- JNP10K-PWR-DC2 Power Supply | 88
- JNP10K-PWR-AC Power Supply LEDs | 90
- JNP10K-PWR-AC2 Power Supply LEDs | 92
- JNP10K-PWR-AC3 Power Supply LEDs | 94
- JNP10K-PWR-DC Power Supply LEDs | 97
- JNP10K-PWR-DC2 Power Supply LEDs | 100

PTX10008 Routing and Control Board Components and Descriptions | 105

- PTX10008 Routing and Control Board Description | 105
- PTX10008 Routing and Control Board LEDs | 109

PTX10008 Switch Fabric | 115

- PTX10008 Switch Interface Board Description | 115
- PTX10008 Switch Interface Board LEDs | 119

PTX10008 Line Card Components and Descriptions | 121

- PTX10K-LC1101 Line Card | 123
- PTX10K-LC1102 Line Card | 126
- PTX10K-LC1104 Line Card | 134
- 1.2-Terabyte Per Second DWDM OTN Module Wavelengths | 144
- PTX10K-LC1105 Line Card | 170
- PTX10K-LC1201-36CD Line Card | 175
- PTX10K-LC1202-36MR Line Card | 181
- QFX10000-60S-6Q Line Card | 187
- PTX10008 Line Card LEDs | 193

Site Planning, Preparation, and Specifications

- PTX10008 Site Preparation Overview | 197**
 - PTX10008 Site Preparation Checklist | 197

PTX10008 Environmental Requirements and Specifications | 199

PTX10008 General Site Guidelines | 200

PTX10008 Site Electrical Wiring Guidelines | 201

PTX10008 Rack Requirements | 202

PTX10008 Clearance Requirements for Airflow and Hardware Maintenance | 205

PTX10008 Power Planning for JNP10008-SF Switch Fabric | 207

Power Requirements for PTX10008 Components in a JNP10008-SF Fabric | 208

Calculate Power Requirements for a PTX10008 | 209

Calculate the Power Consumption of Your PTX10008 Configuration | 210

Calculate the Number of Power Supplies Required for Your PTX10008 Configuration | 212

JNP10K-PWR-AC Power Specifications | 219

JNP10K-PWR-AC2 Power Specifications | 220

JNP10K-PWR-AC3 Power Specifications | 221

PTX10008 Power Cables Specifications | 222

JNP10K-PWR-AC3 Power Cable Specifications | 232

JNP10K-PWR-DC Power Specifications | 242

JNP10K-PWR-DC2 Power Specifications | 243

PTX10008 Power Planning for JNP10008-SF3 Switch Fabric | 244

Power Requirements for PTX10008 Components in a JNP10008-SF3 Fabric | 245

JNP10K-PWR-AC2 Power Specifications | 246

JNP10K-PWR-AC2 Power Cable Specifications | 247

JNP10K-PWR-AC3 Power Specifications | 254

JNP10K-PWR-AC3 Power Cable Specifications | 255

JNP10K-PWR-DC2 Power Specifications | 266

PTX10008 Grounding Cable and Lug Specifications | 267

PTX10008 Transceiver and Cable Specifications | 268

PTX10008 Optical Transceiver and Cable Support | 269

PTX10008 Cable Specifications for Console and Management Connections | 270

PTX10008 Fiber-Optic Cable Signal Loss, Attenuation, and Dispersion | 271

Calculate the Fiber-Optic Cable Power Budget for a QFX Series Router | 272

Calculate the Fiber-Optic Cable Power Margin for a QFX Series Router | 273

PTX10008 Console and Management Cable Specifications and Pinouts | 275

Console Port Connector Pinouts for a PTX10008 | 275

USB Port Specifications for the PTX10008 Router | 277

Management Port Connector Pinouts for the PTX10008 Router | 278

4

Initial Installation and Configuration for New Systems

PTX10008 Installation Overview | 280

Unpack the PTX10008 Router | 281

Unpack the PTX10008 Shipping Pallet | 281

Unpack Line Cards, Routing Control Boards, and Switch Interface Boards for the PTX10008 | 283

Compare the PTX10008 Order to the Packing List | 285

Register Products—Mandatory to Validate SLAs | 291

Mount the PTX10008 by Using the JNP10004-RMK-4POST Rack Mount Kit | 291

Mount the PTX10008 by Using the EX-MOD-RMK-4POST Rack Mount Kit | 298

Install and Maintain the Front Door and its Components on the PTX10008 Router | 304

Install the Front Door on the PTX10008 Router | 305

Install the Air Filter in the JNP10008-FRPNL1 Front Door | 312

Remove the Air Filter from the JNP10008-FRPNL1 Front Door | 314

Remove the Side EMI Deflectors from the Front Door | 318

Remove the Front Door from the PTX10008 Router | 318

Connect the PTX10008 to Power | 320

Connect the PTX10008 Router to Earth Ground | 320

Connect AC Power to a PTX10008 | 322

Connect DC Power to a PTX10008 | 323

Connect the PTX10008 to External Devices | 325

Connect a PTX10008 Router to a Network for Out-of-Band Management | 325

Connect a PTX10008 Router to a Management Console | 326

Connect the Router to External Clocking and Timing Devices | 328

Connect the Router to a 1PPS and 10MHz Timing Device | 328

Connect the Router to a Time-of-Day Device | 329

Connect the Router to a BITS External Clocking Device | 331

Perform the Initial Configuration for the PTX10008 Router | 332

Before You Start | 333

Enter Configuration Mode | 334

Establish a Root Password and Optional Host Name | 335

Configure the Default Gateway and Ethernet Interface | 335

Configure Optional Routes, Services, and Commit the Configuration | 336

5

Hardware Upgrades

PTX10008 Hardware Upgrade Procedures | 339

Before You Begin | 339

Remove PTX10008 Components for Upgrade | 340

Install the PTX10008 Upgrade Components | 340

6

Maintain Components

Install and Remove PTX10008 Routing and Control Boards | 343

Install a PTX10008 Routing and Control Board | 343

Remove a PTX10008 Routing and Control Board | 345

Install and Remove PTX10008 Cooling System Components | 347

Install a PTX10008 Fan Tray | 348

Remove a PTX10008 Fan Tray | 351

Install a PTX10008 Fan Tray Controller | 355

Remove a PTX10008 Fan Tray Controller | 358

Install and Remove PTX10008 Power System Components | 361

- Install a JNP10K-PWR-AC Power Supply | 362
- Troubleshooting an Unsupported Power Supply Unit on Junos OS Evolved | 367
- Remove a JNP10K-PWR-AC Power Supply | 369
- Install a JNP10K-PWR-AC2 Power Supply | 372
- Remove a JNP10K-PWR-AC2 Power Supply | 377
- Install a JNP10K-PWR-AC3 Power Supply | 380
- Remove a JNP10K-PWR-AC3 Power Supply | 388
- Install a JNP10K-PWR-DC Power Supply | 391
- Remove a JNP10K-PWR-DC Power Supply | 401
- Install a JNP10K-PWR-DC2 Power Supply | 405
- Remove a JNP10K-PWR-DC2 Power Supply | 416

Install and Remove PTX10008 Switch Fabric Components | 420

- How to Handle and Store PTX10008 Line Cards, RCBs, and SIBs | 420
 - How to Hold Line Cards and RCBs | 421
 - How to Hold SIBs | 422
 - How to Store Line Cards, RCBs, and SIBs | 424
- Install a PTX10008 Switch Interface Board | 424
- Remove a PTX10008 Switch Interface Board | 429

Install and Remove PTX10008 Line Card Components | 433

- Install a PTX10008 Line Card | 434
- Remove a PTX10008 Line Card | 437
- Install the PTX10008 Cable Management System | 439

PTX10008 Transceiver and Fiber Optic Cable Installation and Removal | 442

- Install a PTX10008 Transceiver | 443
- Remove a Transceiver From a PTX0008 | 444
- Connect a Fiber-Optic Cable from a Transceiver on a PTX10008 Router | 446

Disconnect a Fiber-Optic Cable from a Transceiver on a PTX10008 Router | 447

Fiber-Optic Cable Maintenance for a PTX10008 Router | 448

Remove the PTX10008 Router | 449

Power Off a PTX10008 | 449

Remove a PTX10008 from a Four-Post Rack Using a Mechanical Lift | 452

Remove a PTX10008 Manually from a Four-Post Rack | 454

7

Troubleshoot Hardware

Alarm Messages | 459

Alarms – A Glossary | 459

Interface Alarm Messages | 460

8

Contact Customer Support and Return the Chassis or Components

Contact Customer Support | 463

Return Procedures for the PTX10008 Chassis or Components | 464

Return a PTX10008 Router or Component for Repair or Replacement | 464

Locate the Serial Number on a PTX10008 Router or Component | 465

List the PTX10008 Chassis and Component Details Using the CLI | 466

Locate the Chassis Serial Number ID Label on a PTX10008 | 469

Locate the Serial Number ID Labels on PTX10008 Power Supplies | 470

Locate the Serial Number ID Labels on PTX10008 Fan Trays and Fan Tray Controllers | 473

Locate the Serial Number ID Labels on PTX10008 Routing and Control Boards | 474

Locate the Serial Number ID Labels on a PTX10008 Line Card | 474

Locate the Serial Number ID Labels on a PTX10008 Switch Interface Board (SIB) | 475

Locate the Serial Number ID Label on a PTX10008 SATA SSD | 475

Contact Customer Support to Obtain a Return Materials Authorization for a PTX10008 Router or Component | 476

How to Pack a PTX10008 or Component for Shipping | 477

How to Pack a PTX10008 Chassis for Shipping | 478

How to Pack PTX10008 Components for Shipping | 480

9

Safety and Compliance Information

General Safety Guidelines and Warnings | 484

Definitions of Safety Warning Levels	485
Qualified Personnel Warning	487
Warning Statement for Norway and Sweden	487
Fire Safety Requirements	488
Installation Instructions Warning	489
PTX10008 Chassis Lifting Guidelines	490
Restricted Access Warning	490
Ramp Warning	492
Rack-Mounting and Cabinet-Mounting Warnings	492
Grounded Equipment Warning	496
Radiation from Open Port Apertures Warning	497
Laser and LED Safety Guidelines and Warnings	498
Maintenance and Operational Safety Guidelines and Warnings	501
General Electrical Safety Guidelines and Warnings	507
Action to Take After an Electrical Accident	508
Prevention of Electrostatic Discharge Damage	509
AC Power Electrical Safety Guidelines	510
AC Power Disconnection Warning	511
DC Power Electrical Safety Guidelines for the PTX10008 and PTX10016 Routers	512
DC Power Copper Conductors Warning	513
DC Power Disconnection Warning	514
DC Power Grounding Requirements and Warning	515
DC Power Wiring Sequence Warning	516
DC Power Wiring Terminations Warning	518
Multiple Power Supplies Disconnection Warning	519

TN Power Warning | 520

PTX10008 and PTX10016 Agency Approvals and Compliance Statements | 521

Agency Approvals for the PTX10008 and PTX10016 Routers | 521

Compliance Statements for EMC Requirements for the PTX10008 and PTX10016 Routers | 523

About This Guide

Use this guide to install hardware and perform initial software configuration, routine maintenance, and troubleshooting for the PTX10008 Packet Transport Router.

After completing the installation and basic configuration procedures covered in this guide, refer to the Junos OS and the Junos OS Evolved documentation for information about further software configuration.

If your PTX10008 has JNP10008-SF Switch Interface Boards (SIBs), refer to the [Junos OS documentation](#). If your PTX10008 has JNP10008-SF3 SIBs, refer to the [Junos OS Evolved documentation](#).

1

CHAPTER

Fast Track: Initial Installation

[Fast Track to Rack Installation and Power | 2](#)

[Onboard, Configure, and Monitor the PTX10008 | 12](#)

Fast Track to Rack Installation and Power

SUMMARY

This procedure guides you through the simplest steps for the most common installation to mount your PTX10008 router in a rack and connect it to power. Have more complex installation needs? See ["Mount the PTX10008 by Using the EX-MOD-RMK-4POST Rack Mount Kit" on page 298](#).

IN THIS SECTION

- [Install the PTX10008 in a Rack | 2](#)
- [Connect to Power | 7](#)

Install the PTX10008 in a Rack

IN THIS SECTION

- [Mount the Router | 3](#)

You can install a PTX10008 router in a standard 19-in. (483-mm) equipment rack by using the JNP10004-RMK-4POST rack mount kit or by using the EXMOD-RMK-4POST rack mount kit. We'll walk you through the steps to install a premium redundant configuration PTX10008 router by using the JNP10004-RMK-4POST rack mount kit and connect it to power.

The router chassis weighs approximately 145 lb (66 kg) with only the fan tray controllers installed.

You can mount the router manually or by using a mechanical lift. Because of the router's size and weight, we strongly recommend that you use a mechanical lift to mount the router.

Ensure that you have a mechanical lift rated for 500 lb (226.8 kg).

You must install the router in a restricted-access location and ensure that the chassis is always grounded properly.

Before you install, review the following:

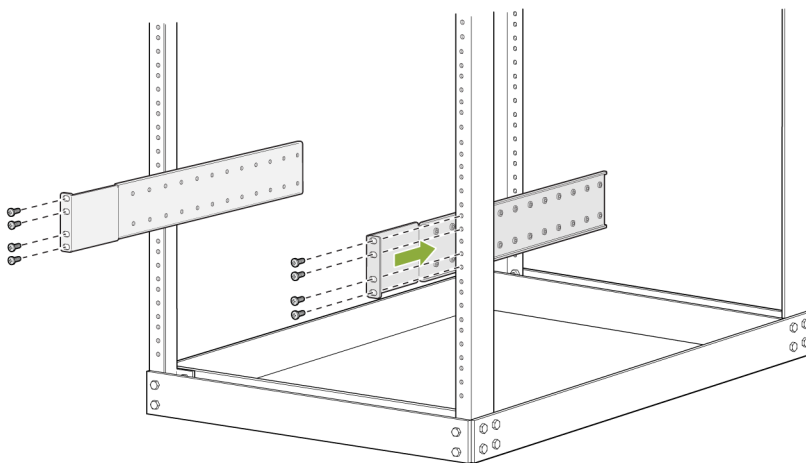
- ["PTX10008 Site Preparation Overview" on page 197](#)

- [General Safety Guidelines and Warnings](#)
- ["Prevention of Electrostatic Discharge Damage" on page 509](#)
- ["Unpack the PTX10008 Router" on page 281](#)
- ["PTX10008 Chassis Lifting Guidelines" on page 490](#)

Mount the Router

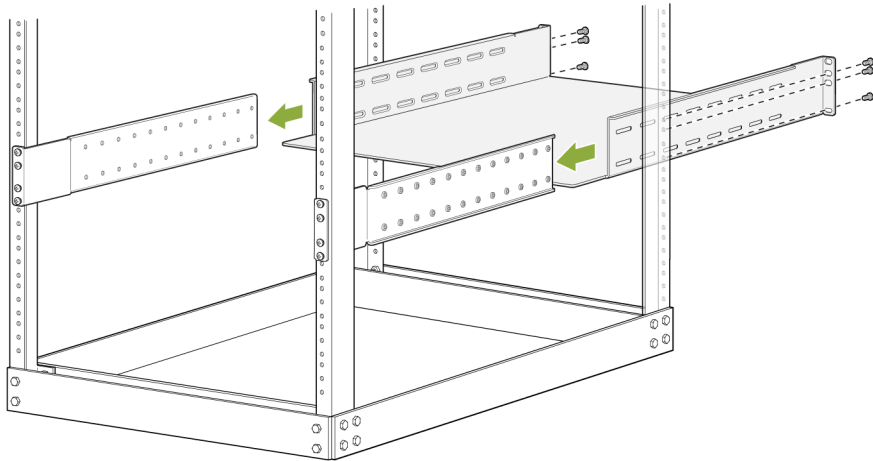
To mount the router:

1. Place the router on a flat, stable surface.
2. Wrap and fasten one end of the ESD grounding strap around your bare wrist, and connect the other end to a site ESD point.
3. Attach the mounting blades to the front rack posts by using eight rack mount screws appropriate for your rack and a screwdriver.



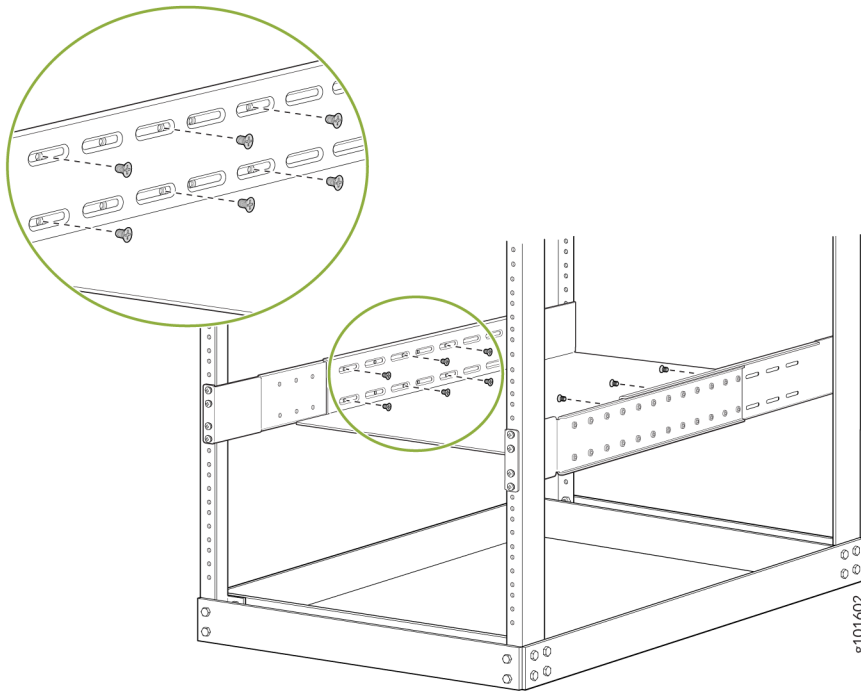
g1101600

4. From the rear of the rack, slide the mounting tray into the rear posts of the rack such that the mounting blades slide into the grooves on the mounting tray. Attach the tray to the rear rack posts by using six rack mount screws appropriate for your rack and a screwdriver.



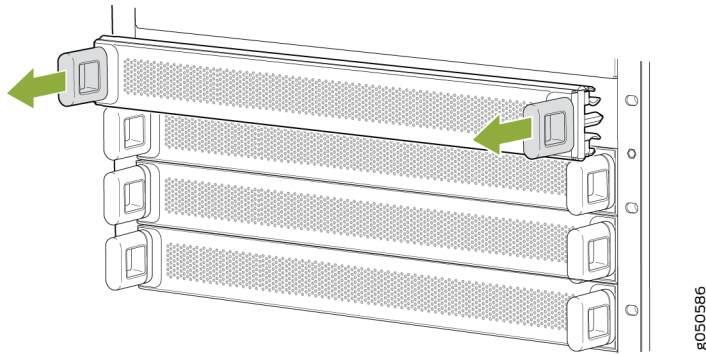
8101601

5. Check that the mounting tray is level.
6. Attach the mounting blades to the tray with the 12 Phillips 8-32 x .375 in. flat-head screws.



8101602

7. Remove the line card slot covers by grasping the handles and pulling the covers straight out.

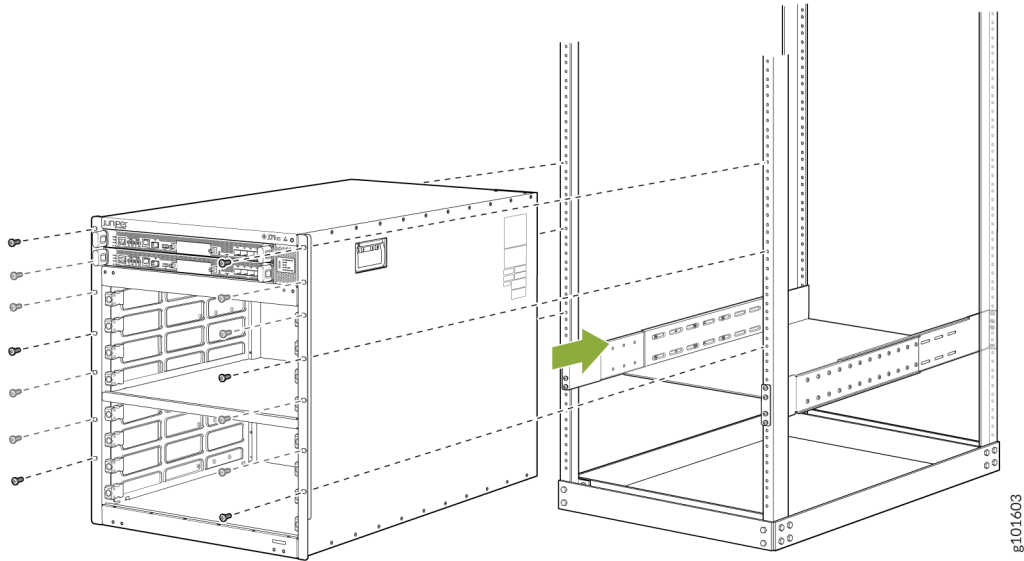


8. Load the router onto the lift, making sure it rests securely on the lift platform.

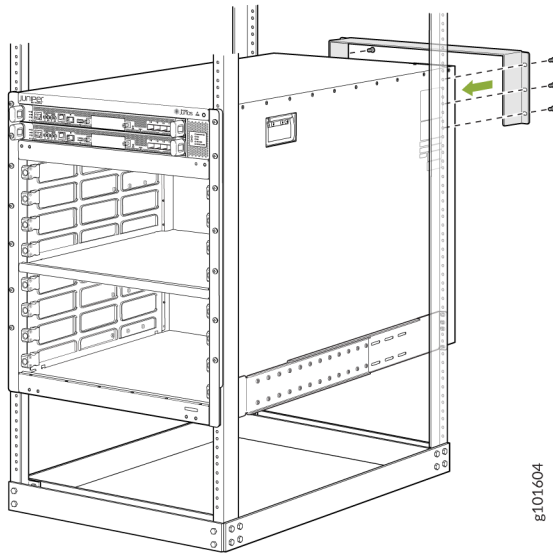


9. By using the lift, align the router in front of the rack, centering it in front of the mounting tray.
10. Lift the chassis approximately 0.75 in. (1.9 cm) above the surface of the mounting tray. Align the chassis as close as possible to the mounting tray.

11. Carefully slide the chassis onto the mounting tray until the chassis flanges contact the rack rails. The mounting blades ensure that the holes in the chassis flanges line up with the holes in the rack rails.
12. Attach the chassis to the rack by installing 14 rack mount screws through each open flange hole and rack hole.



13. Move the lift away from the rack.
14. Check the alignment of the router. The rack mount screws on each side of the rack should line up, and the router should be level. Tighten the screws.
15. Insert the safety restraint between the rear posts of the rack. It should rest on the top of the chassis and align with the holes in the rack.
16. Attach the restraint to the rack by installing six rack mount screws through each open flange hole and rack hole. Tighten the screws.



Connect to Power

IN THIS SECTION

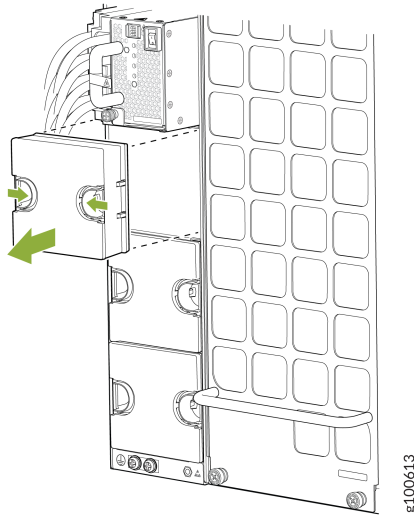
- [Install the Power Supplies | 7](#)
- [Ground the Router | 9](#)
- [Connect the Power Cable and Power On the Router | 10](#)

To connect the router to AC power:

Install the Power Supplies

To install the power supplies:

1. If the power supply slot has a cover on it, insert your thumb and forefinger into the finger holes, squeeze, and pull the cover out of the slot. Save the cover for later use.

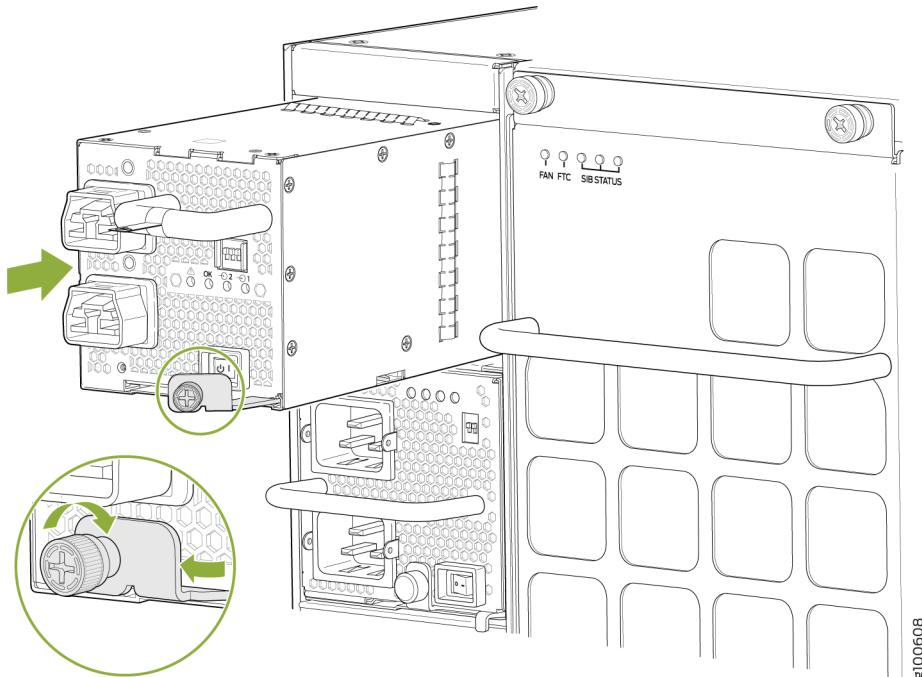


2. Taking care not to touch power supply connections, remove the power supply from its bag.
3. Peel back and remove the protective plastic wrap that covers all four sides of the power supply.
4. Ensure that the power switch is set to the standby (O) position. This switch turns off the output voltage; it does not interrupt input power.
5. Unscrew the captive screw in the counterclockwise direction by using your fingers or by using the Phillips (+) screwdriver, number 1.
6. Rotate the captive screw away from the faceplate of the power supply to release the latch.

NOTE: You can install the power supplies in any slot labeled **PSU 0** through **PSU 5** (top to bottom) on a PTX10008.

7. Using both hands, place the power supply in the power supply slot on the rear of the system. Slide the power supply straight into the chassis until the power supply is fully seated in the slot. Ensure that the power supply faceplate is flush with any adjacent power supply faceplates or power supply

covers.

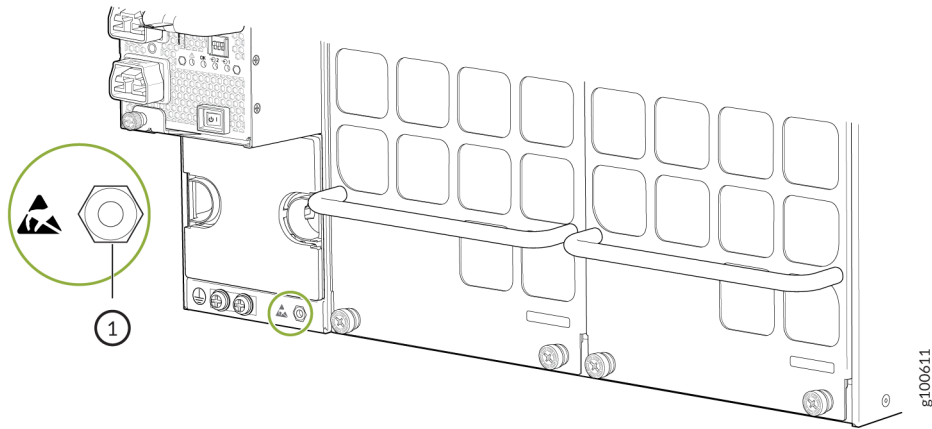


8. Push the captive screw into the power supply faceplate. Ensure that the screw is seated inside the corresponding hole on the faceplate.
9. Tighten the captive screw by turning it clockwise by using your fingers or by using the Phillips (+) screwdriver, number 1. Do not overtighten—do not apply more than 7.3 lb-in (0.82 Nm) of torque to the screws. When the screw is completely tight, the latch locks into the router chassis.

Ground the Router

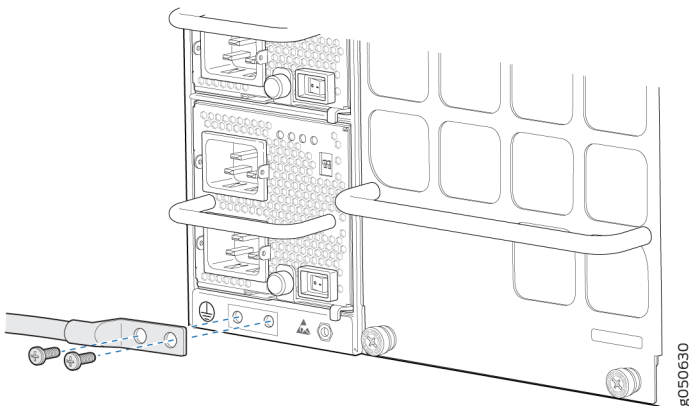
To ground the router:

1. Verify that a licensed electrician has attached the protective earthing terminal lug (provided in the accessory kit) to the grounding cable.
2. Connect the other end of the grounding cable to a proper earth ground, such as the rack in which the router is installed.
3. Wrap and fasten one end of the ESD grounding strap around your bare wrist, and connect the other end of the strap to an ESD point on the chassis. There is an ESD point located next to the protective earthing terminal and below **PSU 5** on the rear of the PTX10008.



1- ESD point

4. Remove the two screws on the earthing terminal adjacent to the ESD point by using a Phillips screwdriver. Save the screws.
5. Place the chassis grounding lug and cable over the screw holes, with the cable connection pointing to the left.



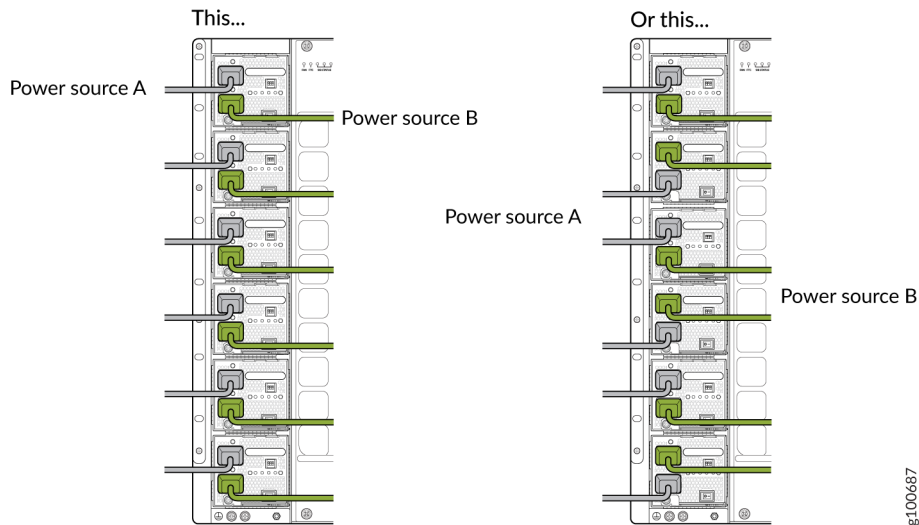
6. Place the two screws over the grounding lug and grounding cable.
7. Tighten the two screws by using a Phillips screwdriver.
8. Dress the grounding cable and ensure that it does not touch or block access to other device components and that it does not drape where people can trip over it.

Connect the Power Cable and Power On the Router

To connect the power cable and power on the router:

1. Attach each power cable to a dedicated power source (A and B). The JNP10K-PWR-AC2 requires that each power supply be connected to a separate source. See [Figure 1 on page 11](#) for a few possible cabling combinations for PTX10008.

Figure 1: Proper Load Balancing for JNP10K-PWR-AC2 Power Cables



2. For each power cable, insert the end of the cable with the Anderson connector into the JNP10K-PWR-AC2 power supply. The connector snaps and locks the cable into position.



WARNING: Ensure that the power cords do not block access to router components or drape where people can trip on them.

3. If the power source outlets have a power switch, set them to the on (I) position.
4. Set the three DIP switches to set the inputs and whether the power supply is running at 3000 W, 5000 W, or 5500 W. See [Table 1 on page 12](#).

Set both enable switches to the **on** position when you are using both the power source inputs. When you are not using source redundancy, set the unused source to the off (O) position. The LED turns red and indicates an error if a source input is not in use and the enable switch is on (I).

Table 1: Set the JNP10K-PWR-AC2 DIP Switches

Switch	State	Description
1	On	INP0 is present.
	Off	INP0 is not present.
2	On	INP1 is present.
	Off	INP1 is not present.
3	On	Enabled for 30-A feed; 5000 W for single feed, 5500 W for dual feeds.
	Off	Enabled for 20-A feed; power supply capacity is 3000 W.

5. Verify that the **INP1** and **INP2** LEDs on the power supply faceplate are lit and are on steadily.
6. Press the power switch to the on (I) position.

Onboard, Configure, and Monitor the PTX10008

IN THIS SECTION

- [Juniper Paragon Automation | 12](#)
- [CLI | 13](#)

Juniper Paragon Automation

You can use Juniper Paragon Automation to onboard, manage, and monitor PTX10008. See the [Juniper Paragon Automation Documentation](#) page for more information.

CLI

To learn more about what you can do with the PTX10008, see [Table 2 on page 13](#).

Table 2: What's Next

If you want to	Then
Customize the basic configuration	See "Perform the Initial Configuration for the PTX10008 Router" on page 332
Explore the software features supported on PTX10008	See Feature Explorer
Configure supported software features on PTX10008	See PTX10008 Documentation

2

CHAPTER

Overview

[PTX10008 System Overview | 15](#)

[PTX10008 Chassis | 44](#)

[PTX10008 Cooling System | 57](#)

[PTX10008 Power System | 75](#)

[PTX10008 Routing and Control Board Components and Descriptions | 105](#)

[PTX10008 Switch Fabric | 115](#)

[PTX10008 Line Card Components and Descriptions | 121](#)

PTX10008 System Overview

IN THIS SECTION

- [PTX10008 Hardware Overview | 15](#)
- [PTX10008 Configurations and Upgrade Options | 31](#)
- [PTX10008 Component Redundancy | 40](#)
- [PTX10008 Hardware and CLI Terminology Mapping | 41](#)

PTX10008 Hardware Overview

IN THIS SECTION

- [System Overview | 16](#)
- [Benefits of the PTX10008 Router | 16](#)
- [Chassis Description | 17](#)
- [Switch Fabric | 19](#)
- [Routing and Control Board | 22](#)
- [Line Cards | 23](#)
- [Cooling System | 25](#)
- [Power Supplies | 26](#)
- [Software | 30](#)

The Juniper Networks PTX10008 Packet Transport Router helps network operators achieve their business goals while effectively handling current and future traffic demands. For more information, read the following topics:

System Overview

The Juniper Networks PTX10008 Packet Transport Router enables cloud and data center operators to smoothly transition from 10-Gigabit and 40-Gigabit Ethernet networks to 100-Gigabit and 400-Gigabit Ethernet high-performance networks. This flexible, 13 rack unit (13-U) modular chassis has eight line card slots.

The switch fabric consists of six Switch Interface Boards (SIBs). There are two models of SIBs that correspond to the two types of switch fabric that support two different types of line cards. The JNP10008-SF SIB supports five standard line cards and operates in standard Junos OS. The JNP10008-SF switch fabric has a 42 Tbps of forwarding capacity. The JNP10008-SF3 SIB supports the 14.4 Tbps line card and operates in Junos OS Evolved systems. In the JNP10008-SF3 switch fabric the forwarding plane can provide 115 Tbps of forwarding capacity.

The PTX10008 (IP core) router is available in both base and redundant configurations for both AC and DC operation. All systems feature front-to-back airflow.

In addition to the device CLI, you can manage and monitor the PTX10008 router by using Juniper Paragon Automation.

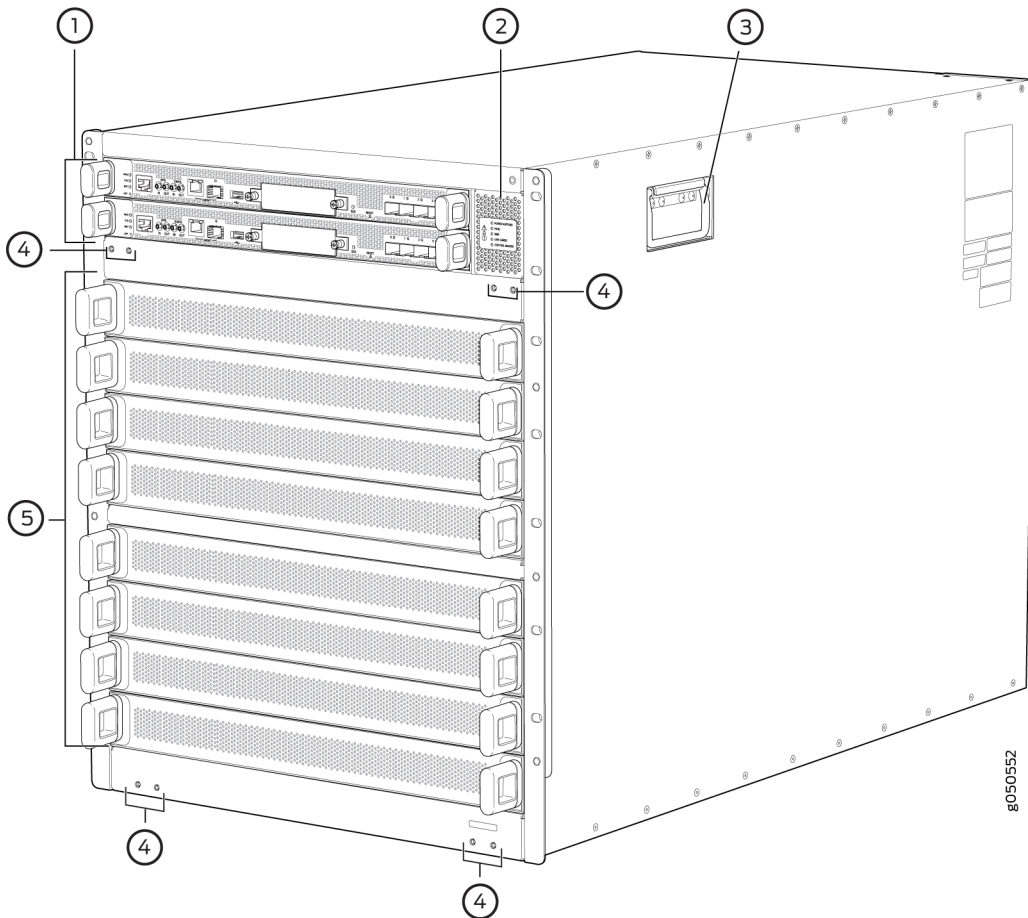
Benefits of the PTX10008 Router

- **System capacity**—The PTX10008 Packet Transport Router has a 13-U form factor and supports 115.2 Tbps per chassis.
- **Full-scale IP and MPLS routing**—PTX10008 software scales to thousands of BGP peers, tens of millions of routes in the routing tables, and supports high forwarding table scale suitable for internet peering deployments.
- **Source Packet Routing in Networking (SPRING)**—SPRING on PTX10008 supports the latest SPRING innovations such as path provisioning via BGP SR-TE, and PCED protocols. It also supports many more features such as Topology independent loop free alternates (TI-LFA) and Operation, Administration, and Maintenance (OAM).
- **Always-on infrastructure base**—The PTX10008 is engineered with full hardware redundancy for cooling, power, switch fabric, and control plane.
- **Nondisruptive software upgrades**—The Junos operating system (Junos OS) on the PTX10008 supports high availability (HA) features such as graceful Routing Engine switchover (GRES), and nonstop active routing (NSR), providing software upgrades and changes without disrupting network traffic.

Chassis Description

The PTX10008 router is 13 U tall. Up to three PTX10008 routers can fit in a standard 42-U rack with adequate cooling and power. All key PTX10008 router components are field-replaceable units (FRUs). [Figure 2 on page 17](#) illustrates the key components visible from the front of the chassis, [Figure 3 on page 18](#) illustrates the components that are visible from the rear of the chassis, and [Figure 4 on page 19](#) illustrates the components that are internal to the chassis.

Figure 2: PTX10008 Chassis Front



1– Routing and Control Boards

4– Installation holes for the front panel

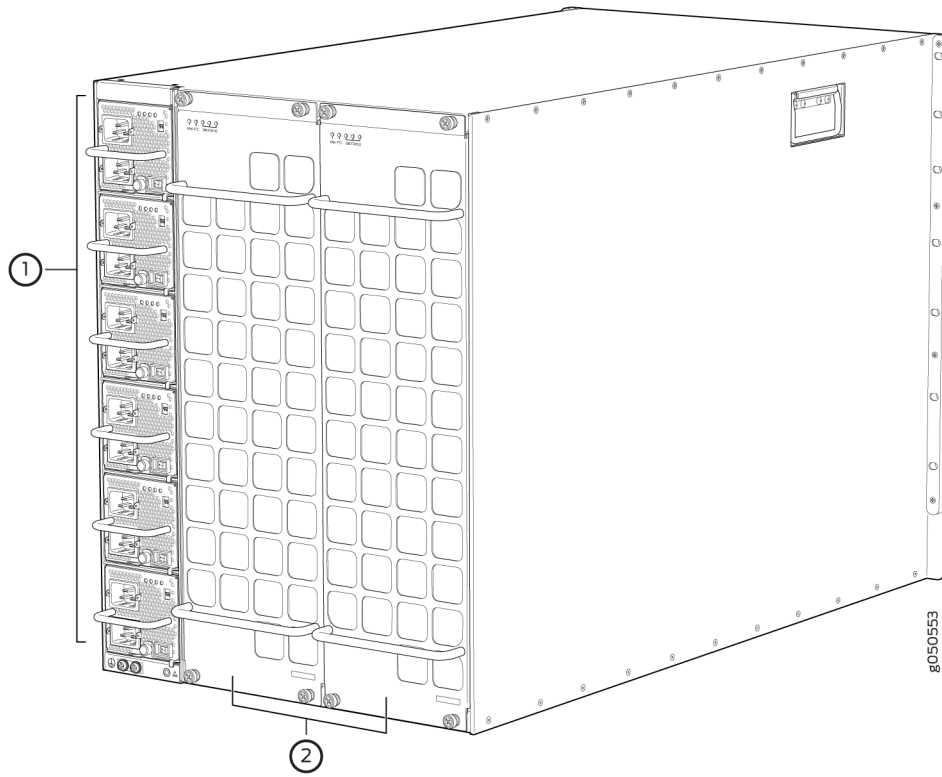
2– Status panel

5– Line card slots 0–7 (numbered top to bottom)

3– Handle

Some chassis ship with an enhanced power bus to future-proof the chassis beyond the current generation of line cards. If you are using any of the JNP10008-SF3 compatible line cards, the standard chassis is sufficient for your operation. You can determine which chassis you have by markings on the status panel (see ["PTX10008 Status Panel"](#) on page 51).

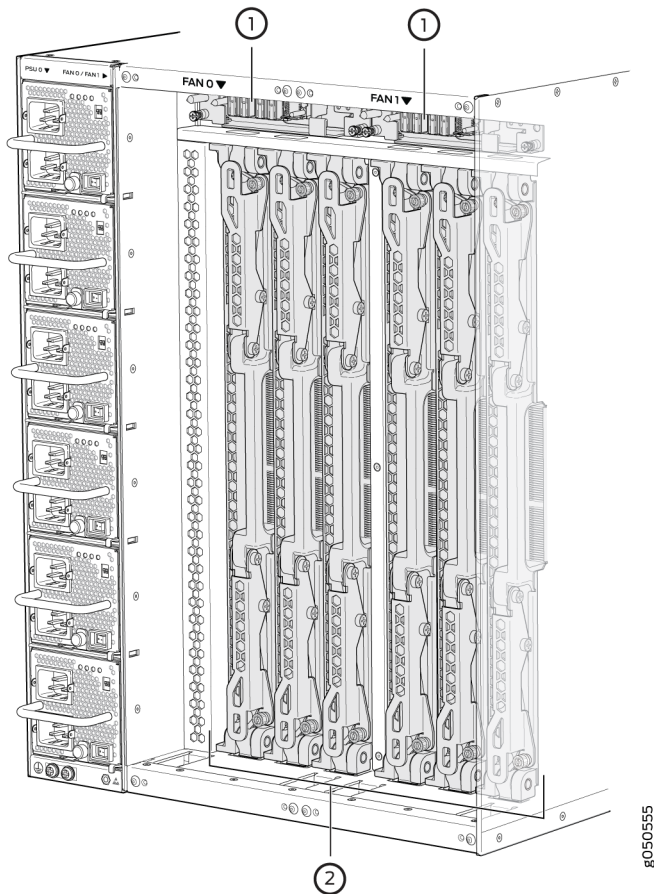
Figure 3: PTX10008 Chassis Rear



1- AC or DC power supplies numbered 0-5 (top to bottom)

2- Fan trays with redundant fans

Figure 4: PTX10008 Chassis Internal Components



1– Fan tray controllers

2– Switch fabric

See ["PTX10008 Chassis Physical Specifications"](#) on page 197 and ["PTX10008 Field-Replaceable Units"](#) on page 49.

Switch Fabric

Switch Interface Boards (SIBs) create the switch fabric for the PTX10008. There are two SIB models: JNP10008-SF and JNP10008-SF3. Each SIB model has a set of unique connectors to mate the line cards and the RCB to the switch fabric. Some system components are also designed to operate with a specific switch fabric. See [Table 3 on page 20](#) for the components that each switch fabric supports. Also see [Figure 5 on page 21](#) for an example of the JNP10008-SF SIB and see [Figure 6 on page 22](#) for an example of JNP10008-SF3.

For the JNP10008-SF switch fabric, five SIBs provide the necessary switching functionality to a PTX10008 router (see [Figure 5 on page 21](#)). Up to six SIBs can be installed to provide $n+1$ redundancy. For the JNP10008-SF3 switch fabric, there are three supported configurations that range from three to

six SIBs. In both switch fabric configurations, SIBs are installed between the line cards and the fan trays inside the chassis. Each PTX10008 SIB has eight connectors that match to a line-card slot, eliminating the need for a backplane. See "[PTX10008 Switch Interface Board Description](#)" on page 115.

Each switch fabric has designated components.

Table 3: Switch Fabric Component Compatibility

Component	JNP10008-SF	JNP10008-SF3
Operating system	Junos OS Release 15.1X53-D30 and later	Junos OS Evolved Release 19.4R1-S1 and later
RCB	<ul style="list-style-type: none"> • JNP10K-RE0 • JNP10K-RE1 • JNP10K-RE1-LT • JNP10K-RE1-128G 	<ul style="list-style-type: none"> • JNP10K-RE1-E • JNP10K-RE1-E128 • JNP10K-RE2-E128 (Junos OS Evolved Release 22.4R1 and later) • JNP10K-RE1-ELT
Fan tray and fan tray controller	JNP10008-FAN with JNP10008-FAN-CTRL or JNP10008-FAN2 with JNP10008-FAN-FTC2	JNP10008-FAN2 with JNP10008-FAN-FTC2
Power supply	<ul style="list-style-type: none"> • JNP10K-PWR-AC • JNP10K-PWR-DC • JNP10K-PWR-AC2 • JNP10K-PWR-DC2 • JNP10K-PWR-AC3 	<ul style="list-style-type: none"> • JNP10K-PWR-AC2 • JNP10K-PWR-DC2 • JNP10K-PWR-AC3

Table 3: Switch Fabric Component Compatibility (Continued)

Component	JNP10008-SF	JNP10008-SF3
Line cards	<ul style="list-style-type: none"> • PTX10K-LC1101 • PTX10K-LC1102 • PTX10K-LC1104 • PTX10K-LC1105 • QFX10000-60S-6Q 	PTX10K-LC1201-36CD PTX10K-LC1202-36MR

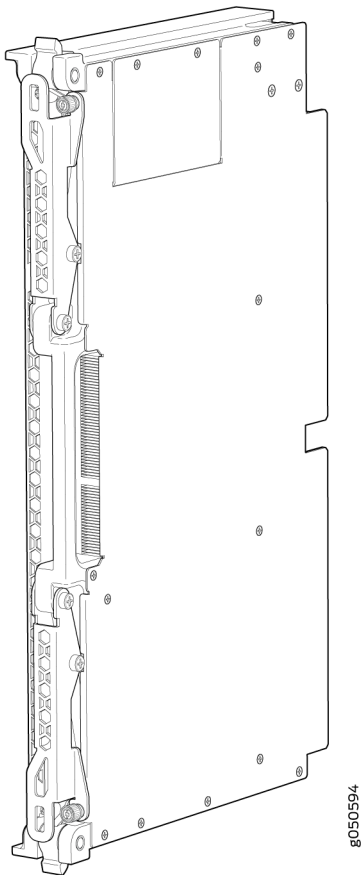
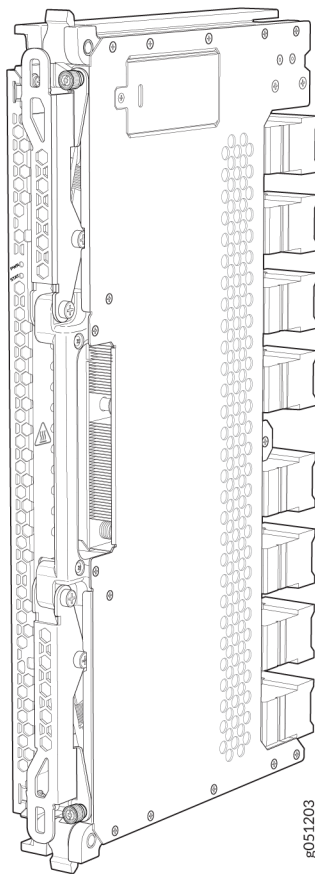
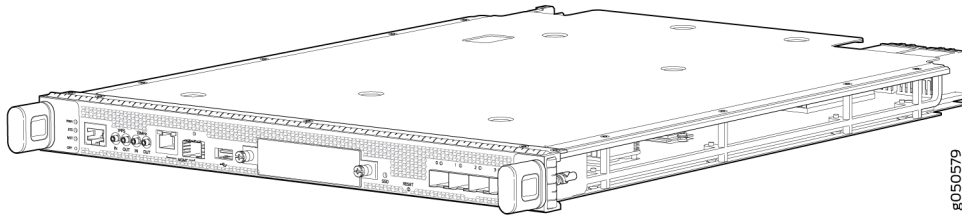
Figure 5: JNP10008-SF SIB

Figure 6: JNP10008-SF3 SIB

Routing and Control Board

The Routing and Control Board (RCB) (see [Figure 7 on page 23](#)) contains a Routing Engine and is responsible for system management and system control in the PTX10008. See "[PTX10008 Routing and Control Board Components and Descriptions](#)" on page 105. RCBs are FRUs that are installed in the front of the chassis in the slots labeled **CB0** and **CB1**. The base configuration has a single RCB. The fully redundant configuration has two RCBs. The RCB also contains Precision Time Protocol (PTP) ports and four Media Access Control Security (MACsec) capable ports. See "[PTX10008 Configurations and Upgrade Options](#)" on page 31.

Figure 7: PTX10008 Routing and Control Board



The supported models of RCB for JNP10008-SF fabric systems are:

- JNP10K-RE0
- JNP10K-RE1
- JNP10K-RE1-LT
- JNP10K-RE1-128G

The supported models of RCB for For JNP10008-SF3 fabric systems are:

- JNP10K-RE1-E
- JNP10K-RE1-ELT (Junos OS Evolved Release 20.3R1 and later)
- JNP10K-RE1-E128
- JNP10K-RE2-E128 (Junos OS Evolved Release 22.4R1 and later).

The RCB comes with Trusted Platform Module (TPM) 2.0 chip that supports DevID.

DevID is an X.509 cryptographic certificate. It is programmed into the TPM 2.0 chip during manufacturing and contains the serial number of the device.

Line Cards

The PTX10008 has eight horizontal line card slots. The line cards combine a Packet Forwarding Engine and Ethernet interfaces enclosed in a single assembly. PTX10008 line card-architecture is based on a number of identical, independent Packet Forwarding Engine slices. Line cards are FRUs that can be installed in the line-card slots labeled **0** through **7** (top to bottom) on the front of the chassis. All line cards are hot-removable and hot-insertable. After the hot insertion, you need to bring the card online (see *Taking a Line Card Online or Offline*).

There are two types of line cards for the PTX10008, those line cards that are compatible with the JNP10008-SF switch fabric and those that are compatible with the JNP10008-SF3 switch fabric. The line cards that operate with the JNP10008-SF switch fabric are:

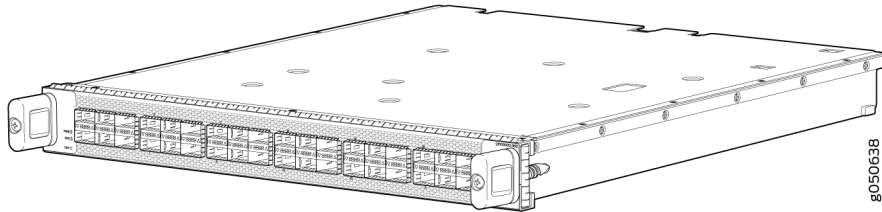
- PTX10K-LC1101, a 30-port 100-Gigabit or 40-Gigabit Ethernet quad small form-factor 28 (QSFP28) line card. By default, the interfaces are created with 100-Gbps port speed. Using the CLI, you can set the speed to 40-Gbps that can be used as either a native 40-gigabit interface or four independent 10-gigabit interfaces using a breakout cable. With breakout cables, the line card supports a maximum of 96 logical 10-Gigabit Ethernet interfaces.
- PTX10K-LC1102, a 36-port 40-Gigabit Ethernet line card that supports quad small form-factor plus (QSFP+) transceivers. Twelve out of the 36 ports on this line card also support the 100-Gigabit Ethernet QSFP28 transceivers. You can configure each of the QSFP+ ports as either a native 40-Gigabit Ethernet interface or channelize the port as four 10-Gigabit Ethernet interfaces by using a breakout cable. When the 40 Gigabit Ethernet port is channelized, the line card supports a maximum of 144 logical 10-Gigabit Ethernet ports.
- PTX10K-LC1104, a 6-port coherent dense wavelength-division multiplexing (DWDM) line card with Media Access Control Security (MACsec). The line card features built-in optics that support flexible rate modulation at 100-Gbps, 150-Gbps, and 200-Gbps speeds.
- PTX10K-LC1105, a 30-port flexible configuration line card that supports QSFP+, QSFP28, QSFP28-DD, QSFP56, and QSFP-DD transceivers. You can configure either as 100-Gigabit Ethernet interfaces or as 40-Gigabit Ethernet interfaces. The PTX10K-LC1105 line card supports MACsec security features.
- QFX10000-60S-6Q, a 66-port multiple speed line card that provides 60 small form-factor pluggable plus (SFP+) ports that support 10-Gbps or 1-Gbps port speeds. The line card also has 2 dual-speed QSFP28 ports that support either 40-Gbps or 100-Gbps port speed, and 4 QSFP+ ports that support 40-Gbps speed.

The line cards that operate with the JNP10008-SF3 switch fabric are:

- PTX10K-LC1201-36CD, a 36-port multiple speed line card that can be configured as 400-Gigabit, 200-Gigabit, 100-Gigabit, 50-Gigabit, 25-Gigabit, or 10-Gigabit Ethernet ports.
- PTX10K-LC1202-36MR, a 36-port line card that has thirty-two QSFP28 ports capable of supporting 100-Gbps speed, and four QSFP56-DD ports capable of supporting 400-Gbps speed.

See [Figure 8 on page 25](#) for an example of a PTX10008 line card.

Figure 8: PTX10K-LC1102 Line Card

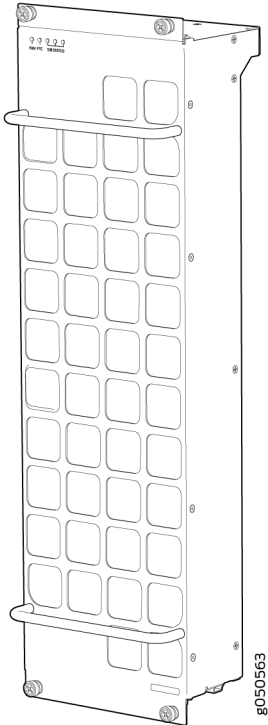


Cooling System

The cooling system in a PTX10008 router consists of two fan trays (see [Figure 9 on page 26](#)) and two fan tray controllers (see [Figure 10 on page 26](#)).

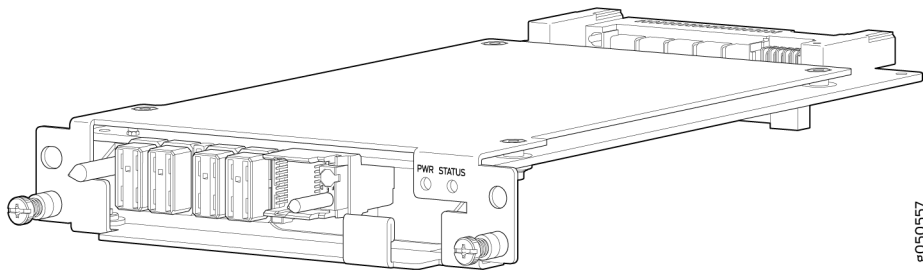
Two fan tray models and their associated fan tray controllers are available. The JNP10008-FAN fan tray contains an array of 11 fans and operates in systems with the JNP10008-SF switch fabric. The JNP10008-FAN2 fan tray contains an array of 22 fans and operates in either the JNP10008-SF switch fabric or in the JNP10008-SF3 switch fabric. These fan arrays operate as a single hot-removable and hot-insertable field-replaceable unit. The fan trays install vertically on the rear of the chassis and provide front-to-back chassis cooling. For model differences, see "[PTX10008 Cooling System and Airflow](#)" on [page 58](#).

Figure 9: Fan Tray JNP10008-FAN



The two fan tray controllers also have two models that correspond to the two fan tray models. JNP10008-FAN-CTRL is the fan controller for the JNP10008-FAN and the JNP10008-FTC2 is the fan tray controller for the JNP10008-FAN2.

Figure 10: Fan Tray Controller JNP10008-FAN-CTRL



Power Supplies

PTX10008 routers support AC, DC, high-voltage alternating current (HVAC) and high-voltage direct current (HVDC), by offering the following power supplies:

- JNP10K-PWR-AC
- JNP10K-PWR-AC2
- JNP10K-PWR-AC3
- JNP10K-PWR-DC
- JNP10K-PWR-DC2

Power supplies for the PTX10008 router are fully redundant, load-sharing, and hot-removable and hot-insertable FRUs. Each PTX10008 router operates with a minimum of three AC power supplies to a maximum of six AC, high-voltage alternating current (HVAC), DC, or high-voltage direct current (HVDC) power supplies. Each power supply has an internal fan for cooling. You can install the power supplies in any slot. See [Figure 11 on page 27](#) through [Figure 15 on page 29](#).



CAUTION: Do not mix power supply models in the same chassis in a running environment. DC and HVDC power supplies can coexist in the same chassis when you hot swap of DC for an HVDC model. The system provides $2n$ source redundancy and $n + 1$ power supply redundancy. If one power source fails, the power supply switches to the alternate source.

Figure 11: JNP10K-PWR AC Power Supply

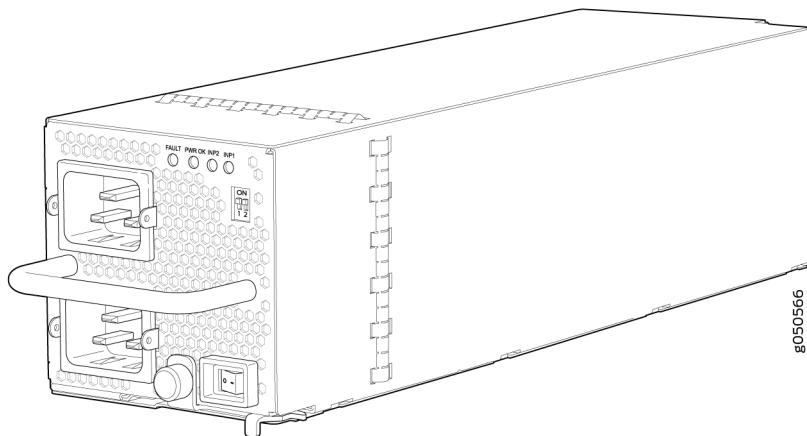
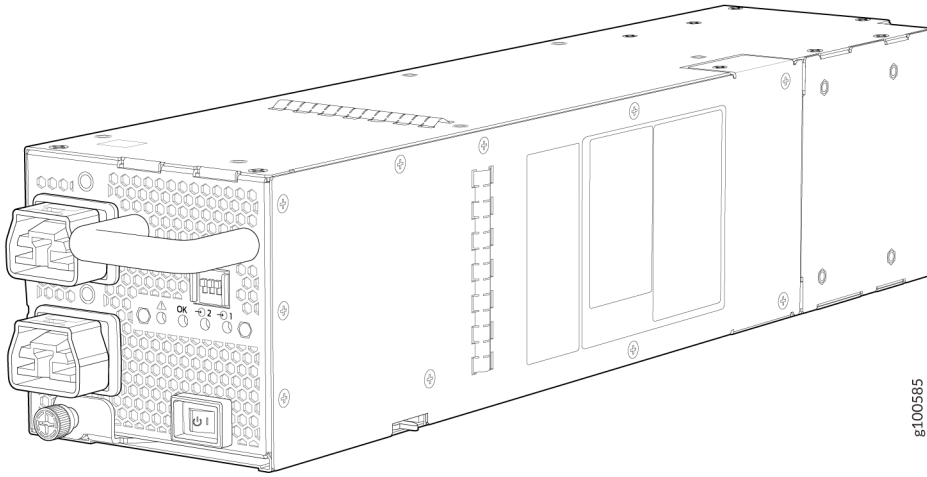
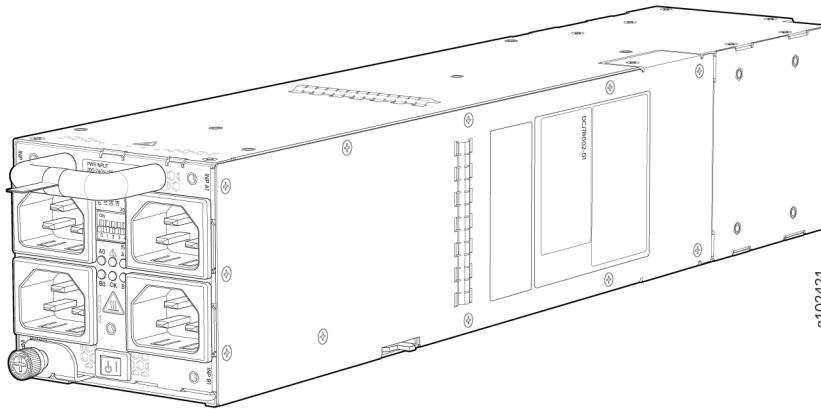


Figure 12: JNP10K-PWR-AC2 Power Supply



g100585

Figure 13: JNP10K-PWR-AC3 Power Supply



g102421

Figure 14: JNP10K-PWR DC Power Supply

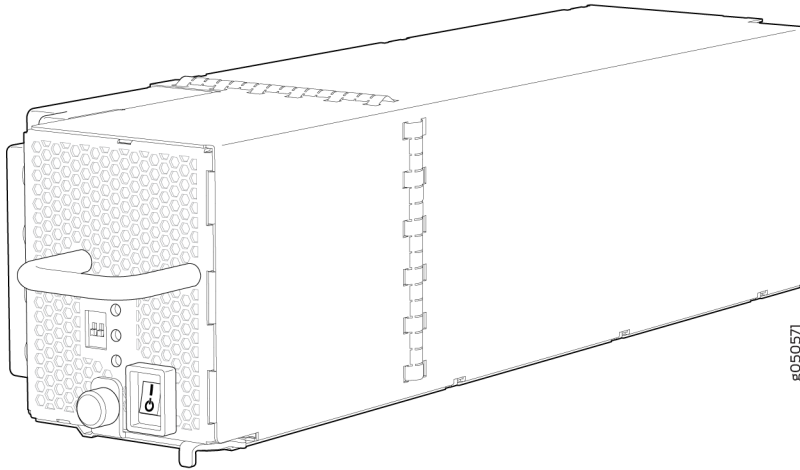


Figure 15: JNP10K-PWR-DC2 Power Supply

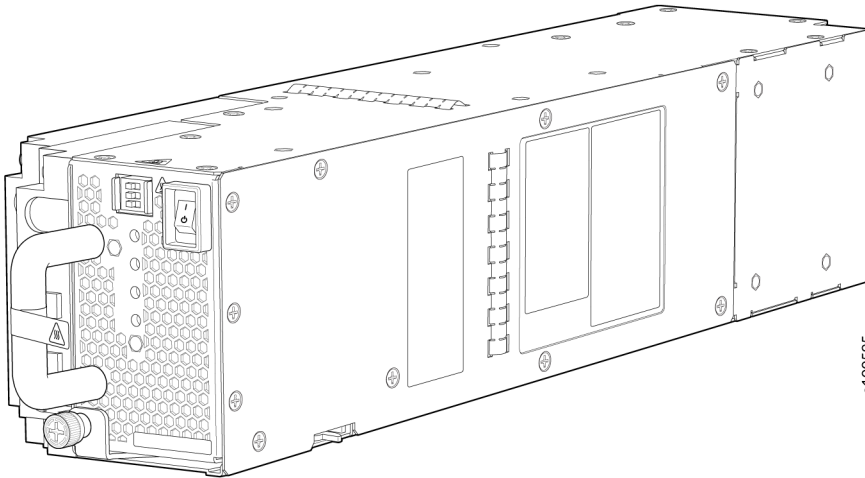


Table 4 on page 29 provides an overview of the differences among the power supplies.

Table 4: Power Supply Overview

Power Supply Model	Input Type	Wattage	Minimum Junos OS Release	Minimum Junos OS Evolved Release
JNP10K-PWR AC	AC only	2700 W	Junos OS 17.2R1	—

Table 4: Power Supply Overview (Continued)

Power Supply Model	Input Type	Wattage	Minimum Junos OS Release	Minimum Junos OS Evolved Release
JNP10K-PWR-AC2	AC, HVAC, or HVDC	5000 W, single feed; 5500 W, dual feed	Junos OS 19.2R1	Junos OS Evolved 19.4R1-S1
JNP10K-PWR-AC3	AC	<ul style="list-style-type: none"> • 7800 W (20-A input) with three or four active feeds • 6000 W (20-A input) with two active feeds • 3000 W (20-A input) with single active feed • 7800 W (15-A input) with four active feeds • 7500 W (15-A input) with three active feeds • 5000 W (15-A input) with two active feeds • 2500 W (15-A input) with single active feed 	—	Junos OS Evolved 23.4R1
JNP10K-PWR-DC	DC only	2500 W	Junos OS 17.2R1	—
JNP10K-PWR-DC2	DC only	2750 W, single feed; 5500 W, dual feed	Junos OS 19.2R1	Junos OS Evolved 19.4R1-S1

Software

The Juniper Networks PTX10008 line of packet transport routers run the Junos operating system (Junos OS), which provides Layer 3 routing services. The same Junos OS code base that runs on the PTX10008 and PTX10016 routers also runs on all Juniper Networks ACX Series Routers, EX Series Ethernet

Switches, QFX Series Switches, M Series Multiservice Edge Routers, MX Series 5G universal Routing Platforms, and SRX Series Firewalls.

SEE ALSO

[PTX10008 Cooling System and Airflow | 58](#)

[PTX10008 Field-Replaceable Units | 49](#)

[PTX10008 Optional Equipment | 55](#)

PTX10008 Configurations and Upgrade Options

IN THIS SECTION

- [PTX10008 Configurations | 31](#)
- [Upgrade Kits | 37](#)

PTX10008 Configurations

[Table 5 on page 32](#) lists the hardware configurations for a PTX10008 modular chassis—base (AC and DC versions), redundant (AC and DC versions), and redundant (HVAC, DC, and HVDC)—and the components included in each configuration.

Table 5: PTX10008 Hardware Configurations

Router Configuration	Configuration Components
Base AC configuration PTX10008-BASE	<ul style="list-style-type: none"> • Chassis • One RCB (JNP10K-RE1, JNP10K-RE1-LT, or JNP10K-RE1-128) • Two fan tray controllers (JNP10008-FAN-CTRL) • Two fan trays (JNP10008-FAN) • Three AC power supplies (JNP10K-PWR-AC) • Three power supply covers • Five SIBs (JNP10008-SF) • One SIB cover (JNP10008-SF-BLNK) • Eight line-card covers • One RCB cover
Base AC configuration with JNP10008-SF3-compatible components PTX10008-BASE3	<ul style="list-style-type: none"> • Chassis • One RCBs (JNP10K-RE1-E, JNP10K-RE1-ELT, JNP10K-RE1-E128, or JNP10K-RE2-E128) • Two fan tray controllers (JNP10008-FTC2) • Two fan trays (JNP10008-FAN2) • Six AC power supplies (JNP10K-PWR-AC2) • Three SIBs (JNP10008-SF3) • Three SIB covers (JNP10008-SF-BLNK2) • Eight line-card covers • One RCB cover

Table 5: PTX10008 Hardware Configurations (Continued)

Router Configuration	Configuration Components
Base DC configuration PTX10008-BASE	<ul style="list-style-type: none"> • Chassis • One RCB (JNP10K-RE1, JNP10K-RE1-LT, or JNP10K-RE1-128) • Two fan tray controllers (JNP10008-FAN-CTRL) • Two fan trays (JNP10008-FAN) • Three DC power supplies (JNP10K-PWR-DC) • Three power supply covers • Five SIBs (JNP10008-SF) • One SIB cover (JNP10008-SF-BLNK) • Eight line-card covers • One RCB cover
Base DC configuration with JNP10008-SF3-compatible components PTX10008-BASE3	<ul style="list-style-type: none"> • Chassis • One RCBs (JNP10K-RE1-E, JNP10K-RE1-ELT, JNP10K-RE1-E128, or JNP10K-RE2-E128) • Two fan tray controllers (JNP10008-FTC2) • Two fan trays (JNP10008-FAN2) • Six DC power supplies (JNP10K-PWR-DC2) • Three SIBs (JNP10008-SF3) • Three SIB covers (JNP10008-SF-BLNK2) • Eight line-card covers • One RCB cover

Table 5: PTX10008 Hardware Configurations (*Continued*)

Router Configuration	Configuration Components
Redundant AC configuration PTX10008-PREMIUM	<ul style="list-style-type: none"> • Chassis • Two RCBs (JNP10K-RE1, JNP10K-RE1-LT, or JNP10K-RE1-128) • Two fan tray controllers (JNP10008-FAN-CTRL) • Two fan trays (JNP10008-FAN) • Six AC power supplies (JNP10K-PWR-AC) • Six SIBs (JNP10008-SF) • Eight line-card covers
Base AC configuration with JNP10008-SF3 compatible components PTX10008-PREM2	<ul style="list-style-type: none"> • Chassis • Two RCBs (JNP10K-RE1-E, JNP10K-RE1-ELT, JNP10K-RE1-E128, or JNP10K-RE2-E128) • Two fan tray controllers (JNP10008-FTC2) • Two fan trays (JNP10008-FAN2) • Six AC power supplies (JNP10K-PWR-AC2) • Four SIBs (JNP10008-SF3) • Two SIB covers (JNP10008-SF-BLNK2) • Eight line-card covers

Table 5: PTX10008 Hardware Configurations (Continued)

Router Configuration	Configuration Components
Redundant AC configuration with JNP10008-SF3 compatible components PTX10008-PREM3	<ul style="list-style-type: none"> • Chassis • Two RCBs (JNP10K-RE1-E, JNP10K-RE1-ELT, JNP10K-RE1-E128, or JNP10K-RE2-E128) • Two fan tray controllers (JNP10008-FTC2) • Two fan trays (JNP10008-FAN2) • Six AC power supplies (JNP10K-PWR-AC2) • Six SIBs (JNP10008-SF3) • Eight line-card covers
Redundant DC configuration PTX10008-PREMIUM	<ul style="list-style-type: none"> • Chassis • Two RCBs (JNP10K-RE1, JNP10K-RE1-LT, or JNP10K-RE1-128) • Two fan tray controllers (JNP10008-FAN-CTRL) • Two fan trays (JNP10008-FAN) • Six DC power supplies (JNP10K-PWR-DC) • Six SIBs (JNP10008-SF3) • Eight line-card covers

Table 5: PTX10008 Hardware Configurations (*Continued*)

Router Configuration	Configuration Components
Base DC configuration with JNP10008-SF3 compatible components PTX10008-PREM2	<ul style="list-style-type: none"> • Chassis • Two RCBs (JNP10K-RE1-E, JNP10K-RE1-ELT, JNP10K-RE1-E128, or JNP10K-RE2-E128) • Two fan tray controllers (JNP10008-FTC2) • Two fan trays (JNP10008-FAN2) • Six AC power supplies (JNP10K-PWR-DC2) • Four SIBs (JNP10008-SF3) • Two SIB covers (JNP10008-SF-BLNK2) • Eight line-card covers
Redundant DC configuration with JNP10008-SF3 compatible components PTX10008-PREM3	<ul style="list-style-type: none"> • Chassis • Two RCBs (JNP10K-RE1-E, JNP10K-RE1-ELT, JNP10K-RE1-E128, or JNP10K-RE2-E128) • Two fan tray controllers (JNP10008-FTC2) • Two fan trays (JNP10008-FAN2) • Six DC power supplies (JNP10K-PWR-DC2) • Six SIBs (JNP10008-SF3) • Eight line-card covers

NOTE: You can install up to eight line cards that support any switch fabric compatible line card in the router.

NOTE: Line cards and the cable management system are not part of the base or redundant configurations. You must order them separately.

NOTE: If you want to purchase additional power supplies (AC, DC, HVAC, or HVDC), SFBs, or RCBs for your router configuration, you must order them separately.

Upgrade Kits

If you would like to be using newer technologies, such as 14.4 Tbps line cards, you can upgrade your existing PTX10008 router, MX10008 router, or QFX10008 switch hardware configurations to become one of the newer PTX10008 hardware offerings. You can convert your existing chassis to a PTX10008 router using an upgrade kit. Upgrading requires JNP10008-FAN2 and 5500 W power supplies. Depending on whether you already have the newer fan trays and power supplies will determine your upgrade kit. You can use [Table 6 on page 37](#) to find the right upgrade kit.

Table 6: Upgrade Kit Matrix

Original Configuration	Upgrading to Configuration	Current Power and Cooling	Order Power Supply Upgrade Kit
PTX10008-BASE	PTX10008-BASE3	JNP10K-PWR-AC and JNP10008-FAN	PTX10008-AC-UPGKIT and PTX10008-B3-UPGKIT
		JNP10K-PWR-AC2 and JNP10008-FAN2	PTX10008-P3-UPGKIT
		JNP10K-PWR-DC and JNP10008-FAN	PTX10008-DC-UPGKIT and PTX10008-B3-UPGKIT
		JNP10K-PWR-DC2 and JNP10008-FAN 2	PTX10008-B3-UPGKIT
PTX10008-BASE	PTX10008-PREM2	JNP10K-PWR-AC and JNP10008-FAN	PTX10008-AC-UPGKIT and PTX10008-P2-UPGKIT

Table 6: Upgrade Kit Matrix (Continued)

Original Configuration	Upgrading to Configuration	Current Power and Cooling	Order Power Supply Upgrade Kit
		JNP10K-PWR-AC2 and JNP10008-FAN2	PTX10008-P2-UPGKIT
		JNP10K-PWR-DC and JNP10008-FAN	PTX10008-DC-UPGKIT and PTX10008-P2-UPGKIT
		JNP10K-PWR-DC2 and JNP10008-FAN 2	PTX10008-P2-UPGKIT
PTX10008-BASE	PTX10008-PREM3	JNP10K-PWR-AC and JNP10008-FAN	PTX10008-AC-UPGKIT and PTX10008-P3-UPGKIT
		JNP10K-PWR-AC2 and JNP10008-FAN2	PTX10008-P2-UPGKIT
		JNP10K-PWR-DC and JNP10008-FAN	PTX10008-DC-UPGKIT and PTX10008-P3-UPGKIT
		JNP10K-PWR-DC2 and JNP10008-FAN 2	PTX10008-P3-UPGKIT
PTX10008-PREMIUM	PTX10008-BASE3	JNP10K-PWR-AC and JNP10008-FAN	PTX10008-AC-UPGKIT and PTX10008-B3-UPGKIT
		JNP10K-PWR-AC2 and JNP10008-FAN2	PTX10008-B3-UPGKIT
		JNP10K-PWR-DC and JNP10008-FAN	PTX10008-DC-UPGKIT and PTX10008-B3-UPGKIT
		JNP10K-PWR-DC2 and JNP10008-FAN 2	PTX10008-B3-UPGKIT

Table 6: Upgrade Kit Matrix (Continued)

Original Configuration	Upgrading to Configuration	Current Power and Cooling	Order Power Supply Upgrade Kit
PTX10008-PREMIUM	PTX10008-PREM2	JNP10K-PWR-AC and JNP10008-FAN	PTX10008-AC-UPGKIT and PTX10008-P2-UPGKIT
		JNP10K-PWR-AC2 and JNP10008-FAN2	PTX10008-P2-UPGKIT
		JNP10K-PWR-DC and JNP10008-FAN	PTX10008-DC-UPGKIT and PTX10008-P2-UPGKIT
		JNP10K-PWR-DC2 and JNP10008-FAN 2	PTX10008-P2-UPGKIT
PTX10008-PREMIUM	PTX10008-PREM3	JNP10K-PWR-AC and JNP10008-FAN	PTX10008-AC-UPGKIT and PTX10008-P3-UPGKIT
		JNP10K-PWR-AC2 and JNP10008-FAN2	PTX10008-P3-UPGKIT
		JNP10K-PWR-DC and JNP10008-FAN	PTX10008-DC-UPGKIT and PTX10008-P3-UPGKIT
		JNP10K-PWR-DC2 and JNP10008-FAN 2	PTX10008-P3-UPGKIT

NOTE: You can install up to eight line cards that support any switch fabric compatible line card in the PTX10008.

NOTE: Line cards and the cable management system are not part of the base or redundant configurations. You must order them separately.

SEE ALSO

[PTX10008 Routing and Control Board Components and Descriptions](#) | 105

[JNP10K-PWR-AC Power Supply](#) | 76

[JNP10K-PWR-DC Power Supply](#) | 86

[PTX10008 Switch Interface Board Description](#) | 115

PTX10008 Component Redundancy

The PTX10008 router is designed so that no single point of failure can cause the entire system to fail. The following major hardware components in the redundant configuration provide redundancy:

- **Routing and Control Board (RCB)**—The RCB consolidates the Routing Engine function with control plane function in a single unit. The PTX10008 router can have one or two RCBs. When two RCBs are installed, one functions as the primary and the other functions as the backup. If the primary RCB (or either of its components) fails, the backup can take over as the primary. See "[PTX10008 Routing and Control Board Components and Descriptions](#)" on page 105.
- **Switch Interface Boards (SIBs)**—The PTX10008 routers have six SIB slots for either the JNP10008-SF or the JNP10008-SF3. You can't mix the two types of SIBs in the same running chassis. For the JNP10008-SF switch fabric, five SIBs provide the necessary switching functionality to a PTX10008 router. Up to six SIBs can be installed to provide $n+1$ redundancy. For the JNP10008-SF3 switch fabric, all six SIBs are required for operation. All six SIBs are active and can sustain full throughput rate. See the "[PTX10008 Switch Interface Board Description](#)" on page 115.
- **Power supplies**—On systems with the JNP10008-SF fabric configuration, the system requires three JNP10K-PWR-AC power supplies for minimum operation (two RCBs, two fan trays, six SIBs, and no line cards). Additional power supplies provide $n+1$ redundancy for the system. DC, HVAC, and HVDC systems require six 5.5KW power supplies and can tolerate a failure of a single power supply without system interruption. If one power supply fails in a fully redundant system, the other power supplies can provide full power to the PTX10008 router indefinitely. In JNP10008-SF3 fabric configurations, six JNP10K-PWR-AC2 or JNP10K-PWR-DC2 power supplies are required for operation.

The PTX10008 router also supports power source redundancy. Two sets of lugs are provided for the JNP10K-PWR-DC cables, four sets of lugs are provided for the JNP10K-PWR-DC2 cables, two AC power cords are provided for each JNP10K-PWR-AC and JNP10K-PWR-AC2 power supply, and four AC power cords are provided for each JNP10K-PWR-AC3 power supply.

- **Cooling system**—The PTX10008 has two fan trays with redundant fans, which are controlled by the fan tray controller. There are two models of fans, JNP10008-FAN and JNP10008-FAN2; each fan model has a corresponding fan tray controller (JNP10008-FAN-CTRL and JNP10008-FAN-FTC2). If one of the fans in a JNP10008-FAN fan tray fails, the host subsystem increases the speed of the

remaining fans to provide sufficient cooling for the router indefinitely. Each fan module itself consists of two independently driven counter-rotating fans. It is an extremely low-probability event that both fans within a fan module will fail. If one of the fans in a JNP10008-FAN2 fan tray fails, under most conditions the fan tray will rebalance the remaining fans to continue. A system receiving half the airflow has adequate time to replace the failing fan tray, even if the temperature rises within the chassis.

Each fan tray controller drives four different fan tray power rails that are isolated from each other. In the event one rail fails, only a quarter of the fans in that fan tray are impacted. The fans driven by each rail are distributed throughout the fan tray in such a manner, that all line cards slots are equally affected. Also, unless the system is already running with all fans at maximum fan speed, other fans can increase their speed to compensate for a rail failure. See ["PTX10008 Cooling System and Airflow" on page 58](#).

SEE ALSO

[PTX10008 Configurations and Upgrade Options | 31](#)

PTX10008 Hardware and CLI Terminology Mapping

This topic describes the hardware terms used in PTX10008 router documentation and the corresponding terms used in the Junos OS CLI. See [Table 7 on page 41](#).

Table 7: CLI Equivalents of Terms Used in Documentation for PTX10008 Routers

Hardware Item (CLI)	Description (CLI)	Value (CLI)	Item In Documentation	Additional Information
Chassis	PTX10008	-	Router chassis	"PTX10008 Chassis Physical Specifications" on page 197

Table 7: CLI Equivalents of Terms Used in Documentation for PTX10008 Routers (*Continued*)

Hardware Item (CLI)	Description (CLI)	Value (CLI)	Item In Documentation	Additional Information
Fan tray	JNP10008-FAN or JNP10008-FAN2	Fan Tray $\theta/1$ Fan n n is a value in the range of 0–10 for the JNP10008-FAN and 0–21 for the JNP10008-FAN2. The value corresponds to the individual fan number in the fan tray.	Fan tray	"PTX10008 Cooling System and Airflow" on page 58
FPC (n)	Abbreviated name of the Flexible PIC Concentrator (FPC) On PTX10008, an FPC is equivalent to a line card.	n is a value in the range of 0–7 for the PTX10008. The value corresponds to the line-card slot number in which the line card is installed.	Line card (The router does not have actual FPCs—the line cards are the FPC equivalents on the router.)	<i>Understanding Interface Naming Conventions</i>
PIC (n)	–	Value of n is always 0.	–	<i>Understanding Interface Naming Conventions</i>

Table 7: CLI Equivalents of Terms Used in Documentation for PTX10008 Routers (*Continued*)

Hardware Item (CLI)	Description (CLI)	Value (CLI)	Item In Documentation	Additional Information
PSM (<i>n</i>)	<p>Abbreviation for power supply module</p> <p>One of the following:</p> <ul style="list-style-type: none"> • JNP10K-PWR-AC • JNP10K-PWR-AC2 • JNP10K-PWR-AC3 • JNP10K-PWR-DC • JNP10K-PWR-DC2 	<p><i>n</i> is a value in the range of 0–5. The value corresponds to the power-supply slot number.</p>	AC, DC, HVAC, or HVDC power supply	<p>One of the following:</p> <ul style="list-style-type: none"> • "JNP10K-PWR-AC Power Supply" on page 76 • "JNP10K-PWR-AC2 Power Supply" on page 78 • "JNP10K-PWR-AC3 Power Supply" on page 81 • "JNP10K-PWR-DC Power Supply" on page 86 • "JNP10K-PWR-DC2 Power Supply" on page 88
Routing Engine	RE (<i>n</i>)	<p><i>n</i> is a value in the range of 0–1.</p> <p>Multiple line items appear in the CLI if more than one RCB is installed in the chassis.</p>	RCB	<p>"PTX10008 Routing and Control Board Components and Descriptions" on page 105</p>

Table 7: CLI Equivalents of Terms Used in Documentation for PTX10008 Routers (*Continued*)

Hardware Item (CLI)	Description (CLI)	Value (CLI)	Item In Documentation	Additional Information
SIB (<i>n</i>)	<p>This field indicates:</p> <ul style="list-style-type: none"> State of the fabric plane: <ul style="list-style-type: none"> Active Spare Check state Status of the Packet Forwarding Engine in each fabric plane: <ul style="list-style-type: none"> Links OK Error 	<i>n</i> is a value in the range of 0–5.	Fabric plane	<i>show chassis fabric sibs</i>
Xcvr (<i>n</i>)	Abbreviated name of the transceiver	<i>n</i> is a value equivalent to the number of the port in which the transceiver is installed.	Optical transceivers	"PTX10008 Optical Transceiver and Cable Support" on page 269

PTX10008 Chassis

IN THIS SECTION

- [PTX10008 Chassis Physical Specifications | 45](#)
- [PTX10008 Field-Replaceable Units | 49](#)

- PTX10008 Status Panel | 51
- PTX10008 Optional Equipment | 55

The PTX10008 chassis houses the hardware components. The chassis components include the fan trays, fan tray controllers, power supplies, Routing and Control Boards (RCBs), line cards, optional cable management system, and the status panel.

PTX10008 Chassis Physical Specifications

The PTX10008 modular chassis is a rigid sheet-metal structure that houses the other router components. You can mount up to three PTX10008 routers in a standard 19-in. 4-post rack (42 U) provided the rack can handle the combined weight and there is adequate power and cooling. [Table 8 on page 45](#) summarizes the physical specifications of the chassis. See [Figure 16 on page 48](#).

Table 8: PTX10008 Router Physical Specifications

Description	Weight	Height	Width	Depth
Chassis, spare	145.2 lb (65.86 kg)	22.6 in. (57.4 cm)	17.4 in. (44.2 cm) NOTE: The outer edges of the chassis flange extend the width to 19 in. (48.3 cm).	32 in. (81.28 cm) chassis only
Chassis base AC configuration	273 lb (123.83 kg)	22.6 in. (57.4 cm)	17.4 in. (44.2 cm) NOTE: The outer edges of the chassis flange extend the width to 19 in. (48.3 cm).	35 in. (88.9 cm) with JNP10K-PWR-AC power supplies 42.4 in. (107.7 cm) with EMI door

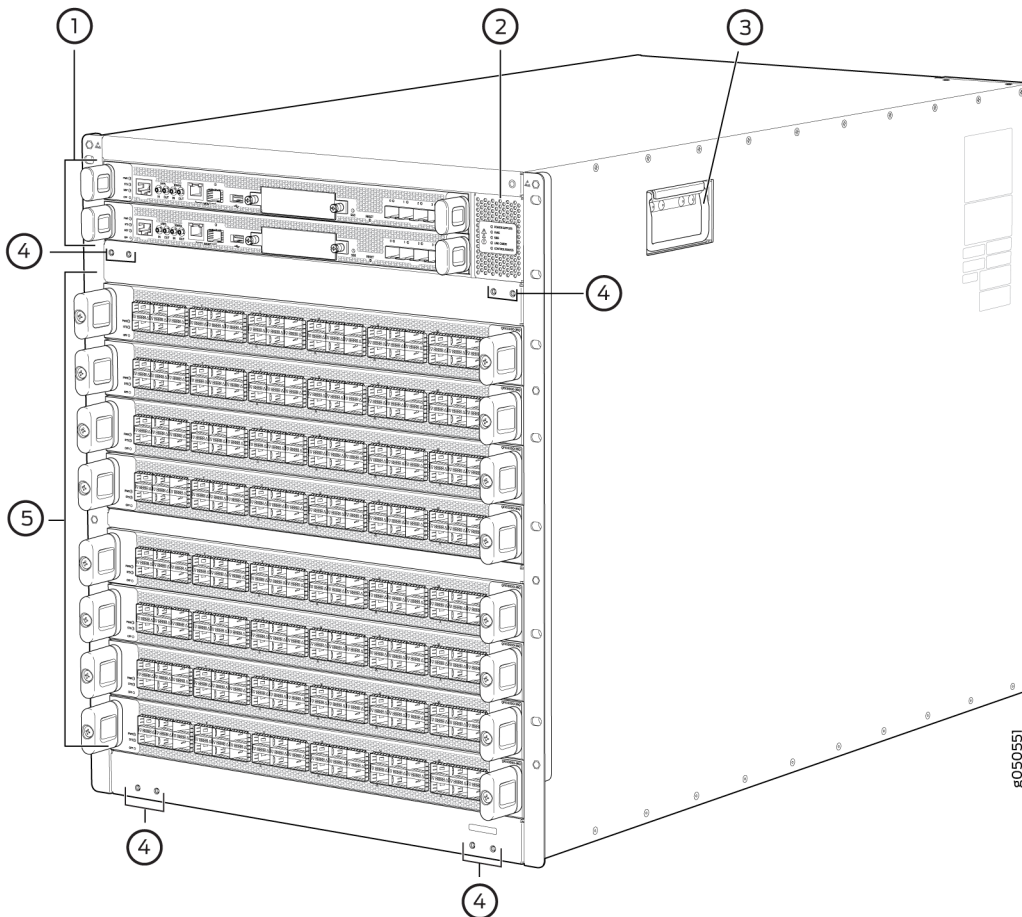
Table 8: PTX10008 Router Physical Specifications (Continued)

Description	Weight	Height	Width	Depth
Chassis base DC configuration	270 lb (122.47 kg)	22.6 in. (57.4 cm)	17.4 in. (44.2 cm) NOTE: The outer edges of the chassis flange extend the width to 19 in. (48.3 cm).	35 in. (88.9 cm) with JNP10K-PWR-DC power supplies 42.4 in. (107.7 cm) with EMI door
Chassis BASE3 AC configuration	394.05 lb (178.74 kg)	22.6 in. (57.4 cm)	17.4 in. (44.2 cm) NOTE: The outer edges of the chassis flange extend the width to 19 in. (48.3 cm).	36.7 in. (93.2 cm) with JNP10K-PWR-AC2 power supplies 44.1 in. (112 cm) with EMI door
Chassis PREM2 AC configuration	390.85 lb (177.29 kg)	22.6 in. (57.4 cm)	17.4 in. (44.2 cm) NOTE: The outer edges of the chassis flange extend the width to 19 in. (48.3 cm).	36.7 in. (93.2 cm) with JNP10K-PWR-AC2 power supplies 44.1 in. (112 cm) with EMI door
Chassis PREM2 DC configuration	375.65 (170.39 kg)	22.6 in. (57.4 cm)	17.4 in. (44.2 cm) NOTE: The outer edges of the chassis flange extend the width to 19 in. (48.3 cm).	36.7 in. (93.2 cm) with JNP10K-PWR-DC2 power supplies 44.1 in. (112 cm) with EMI door
Chassis PREMIUM redundant AC configuration	353 lb (160.12 kg)	22.6 in. (57.4 cm)	17.4 in. (44.2 cm) NOTE: The outer edges of the chassis flange extend the width to 19 in. (48.3 cm).	35 in. (88.9 cm) with JNP10K-PWR-AC power supplies 42.4 in. (107.7 cm) with EMI door

Table 8: PTX10008 Router Physical Specifications (Continued)

Description	Weight	Height	Width	Depth
Chassis PREMIUM redundant DC configuration	350.6 lb (159 kg)	22.6 in. (57.4 cm)	17.4 in. (44.2 cm) NOTE: The outer edges of the chassis flange extend the width to 19 in. (48.3 cm).	35 in. (88.9 cm) with JNP10K-PWR-DC power supplies 42.4 in. (107.7 cm) with EMI door
Chassis redundant AC PTX10008-PREM3 configuration	421.25 lb (191.07 kg)	22.6 in. (57.4 cm)	17.4 in. (44.2 cm) NOTE: The outer edges of the chassis flange extend the width to 19 in. (48.3 cm).	36.7 in. (93.2 cm) with JNP10K-PWR-AC2 power supplies 44.1 in. (112 cm) with EMI door
PTX10K-LC1101 Line Card	27 lb (12.2 kg)	1.89 in. (4.8 cm)	17.2 in. (43.7 cm)	20.54 in. (52.2 cm)
PTX10K-LC1102 Line Card	22.6 lb (10.2 kg)	1.89 in. (4.8 cm)	17.2 in. (43.7 cm)	20.54 in. (52.2 cm)
PTX10K-LC1104 Line Card	32 lb (14.5 kg)	1.89 in. (4.8 cm)	17.2 in. (43.7 cm)	20.54 in.(52.2 cm)
PTX10K-LC1105 Line Card	28.5 lb (12.9 kg)	1.89 in. (4.8 cm)	17.2 in. (43.7 cm)	20.54 in.(52.2 cm)
QFX10000-60S-6Q Line Card	21.4 lb (9.7 kg)	1.89 in. (4.8 cm)	17.2 in. (43.7 cm)	20.54 in.(52.2 cm)
JNP10K-LC1201 Line Card	29.2 lb (13.2 kg)	1.89 in. (4.8 cm)	17.2 in. (43.7 cm)	21.3 in. (54.1 cm)
JNP10K-LC1202 Line Card	21 lb (9.5 kg)	1.9 in. (4.8 cm)	17.2 in. (43.68 cm)	21.3 in. (54.1 cm)

Figure 16: Front View of PTX10008



1– RCBs

2– Status panel

3– Handles

4– Mounting holes for front door

5– Line cards



WARNING: The handles on each side of the chassis facilitate the fine-tune positioning of the chassis on the base brackets. Do not use the handles to lift the chassis, even when the chassis is empty. See ["Mount the PTX10008 by Using the JNP10004-RMK-4POST Rack Mount Kit"](#) on page 291 or ["Mount the PTX10008 by Using the EX-MOD-RMK-4POST Rack Mount Kit"](#) on page 298 for instructions for properly moving a loaded chassis.

SEE ALSO

[PTX10008 Rack Requirements](#) | 202

PTX10008 Field-Replaceable Units

Field-replaceable units (FRUs) are router components that you can replace at your site. The router uses the following types of FRUs:

- Hot-insertable and hot-removable—You can remove and replace these components without powering off the router or disrupting the routing function.
- Hot-pluggable—You can remove and replace these components without powering off the router, but the routing function is interrupted until you replace the component.

[Table 9 on page 49](#) lists the FRUs and their types for the PTX10008 routers.

Table 9: FRUs in an PTX10008 Router

FRU	Type
Power supplies	Hot-insertable and hot-removable.
Fan trays	Hot-insertable and hot-removable.
Fan tray controllers	Hot-insertable and hot-removable.

Table 9: FRUs in an PTX10008 Router (*Continued*)

FRU	Type
Routing and Control Boards (RCBs)	<p>Redundant configuration:</p> <ul style="list-style-type: none"> • Primary RCB is hot-pluggable. • Backup RCB is hot-insertable and hot-removable. <p>Base configuration:</p> <ul style="list-style-type: none"> • Removal of the RCB causes the router to shut down. In order to prevent a disruption in traffic, take the chassis offline. If a temporary disruption is acceptable, you can install a replacement RCB in the second slot. The system restarts to elect a primary RCB and a backup RCB. If necessary, you can switch the primary and backup RCB using the <code>request chassis routing-engine master switch</code> command. <p>See "PTX10008 Configurations and Upgrade Options" on page 31.</p>
Switch Interface Boards (SIBs)	<p>SIBs are hot-insertable and hot-removable. We recommend that you take SIBs offline before removing them to avoid traffic loss while the router fabric is being reconfigured. Use the following command:</p> <pre>user@router> request chassis sib slot <i>slot-number</i> offline</pre>
Line cards	<p>Hot-insertable. We recommend that you take line cards offline before removing them. Use the following command:</p> <pre>user@router> request chassis fpc-slot <i>slot-number</i> offline</pre>
Optical transceivers	<p>Hot-insertable and hot-removable.</p> <p>See "PTX10008 Optical Transceiver and Cable Support" on page 269 for how to find detailed specifications and the Junos OS release in which the transceivers were introduced.</p>

NOTE: Line cards are not part of the base or redundant configuration. You must order them separately.

NOTE: If you have a Juniper Care service contract, register any addition, change, or upgrade of hardware components at <https://www.juniper.net/customers/support/tools/updateinstallbase/>. Failure to do so can result in significant delays if you need replacement parts. This note does not apply if you replace an existing component with the same type of component.

SEE ALSO

[PTX10008 Configurations and Upgrade Options | 31](#)

[PTX10008 Optical Transceiver and Cable Support | 269](#)

PTX10008 Status Panel

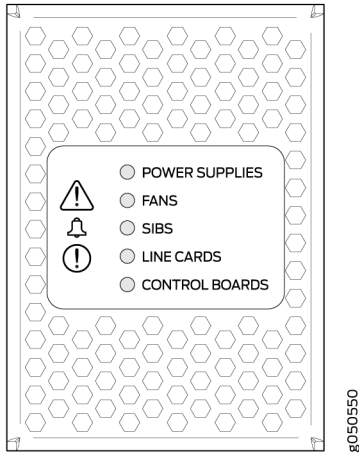
The status panel of the PTX10008 has two purposes:

- Shows the overall status of the chassis
- Indicates the type of power bus internal to the chassis

Some chassis ship with an enhanced power bus to future-proof the chassis for potential power growth.

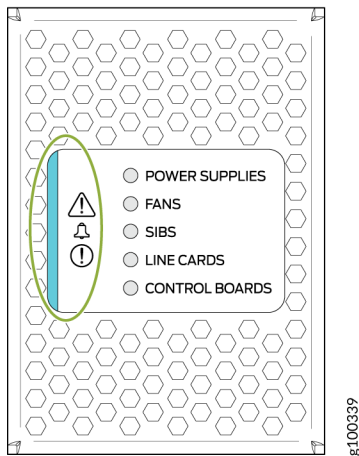
The status panel indicates the chassis status through a set of five bicolor LEDs. See [Figure 17 on page 52](#) for a chassis status panel with the standard power bus.

Figure 17: Status Panel on Chassis with the Standard Power Bus



Other chassis also have the same set of five bicolor LEDs, but also have an azure blue line to indicate the presence of the enhanced power bus (see [Figure 18 on page 52](#)).

Figure 18: Status Panel on Chassis with the Enhanced Power Bus



[Table 10 on page 52](#) describes the status panel LEDs.

Table 10: Status Panel LEDs in a PTX10008

Name	Color	State	Description
! Minor alarm (Triangle warning symbol)	Yellow	Off	No minor alarms are active.

Table 10: Status Panel LEDs in a PTX10008 (Continued)

Name	Color	State	Description
		On steadily	A minor alarm is active.
! Major alarm (Circle warning symbol)	Red	Off	No major alarms are active.
		On steadily	A major alarm is active.
POWER SUPPLIES	Green	On steadily	All of the power supplies are online and operating normally.
	Yellow	On steadily (if Junos OS Evolved is installed in your router)/Blinking (if Junos OS is installed in your router)	One or more of the power supplies has an error.
	None	Off	None of the power supplies is receiving power.
FANS	Green	On steadily	The fans and the fan tray controllers are online and operating normally.
	Yellow	On steadily (if Junos OS Evolved is installed in your router)/Blinking (if Junos OS is installed in your router)	There is an error in a fan or in one of the fan tray controllers.
	None	Off	The fan tray controllers and fan trays are not receiving power.

Table 10: Status Panel LEDs in a PTX10008 (Continued)

Name	Color	State	Description
SIBS	Green	On steadily	At least one installed Switch Interface Board (SIB) is online.
	Yellow	On steadily (if Junos OS Evolved is installed in your router)/Blinking (if Junos OS is installed in your router)	There is a hardware error in one or more SIBs.
	None	Off	All the SIBs are offline.
LINE CARDS	Green	On steadily	At least one installed line card is online.
	Yellow	On steadily (if Junos OS Evolved is installed in your router)/Blinking (if Junos OS is installed in your router)	There is a hardware error in one or more line cards.
	None	Off	All the line cards are offline.
CONTROL BOARDS	Green	On steadily	All installed Routing and Control Boards (RCBs) are online.
	Yellow	On steadily (if Junos OS Evolved is installed in your router)/Blinking (if Junos OS is installed in your router)	One or more RCBs have an error condition.

Table 10: Status Panel LEDs in a PTX10008 (Continued)

Name	Color	State	Description
	None	Off	The installed RCBs are offline.

SEE ALSO

[PTX10008 Line Card Components and Descriptions | 121](#)

[PTX10008 Cooling System and Airflow | 58](#)

[PTX10008 Switch Fabric | 115](#)

[PTX10008 Power System | 75](#)

PTX10008 Optional Equipment

IN THIS SECTION

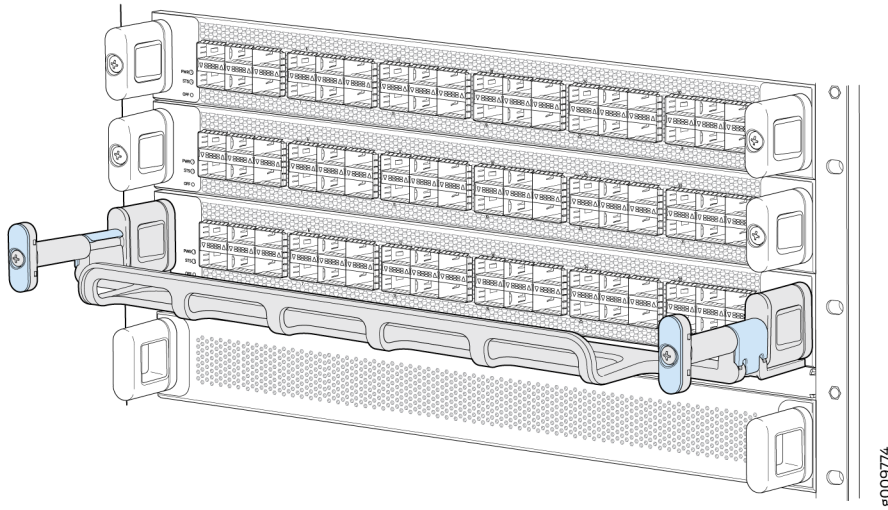
- [PTX10008 Cable Management System | 55](#)

The PTX10008 routers supports the cable management system (JLC-CBL-MGMT-KIT) as an optional equipment:

PTX10008 Cable Management System

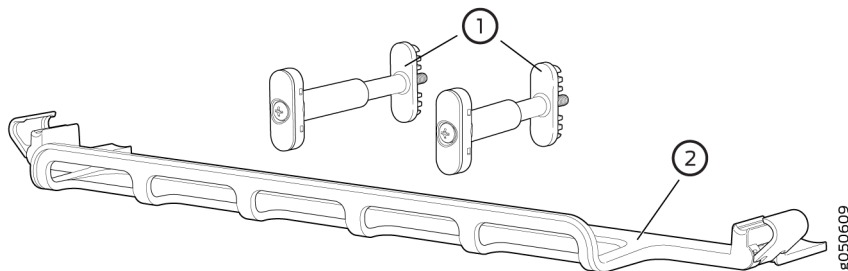
You can use the PTX10008 cable management system (see [Figure 19 on page 56](#)) to route optical cables away from the line-card ports for better airflow through the chassis. Using this optional system also makes it easier to use cable ties or strips to organize the cabling.

Figure 19: PTX10008 Cable Management System



The cable management system comprises a set of handle extensions and a tray that snaps to the extensions (see [Figure 20 on page 56](#)) for an individual line card. You can use the handle extensions with or without the cable tray. You don't need to remove the handle extensions if you want to remove a line card.

Figure 20: Cable Management Parts

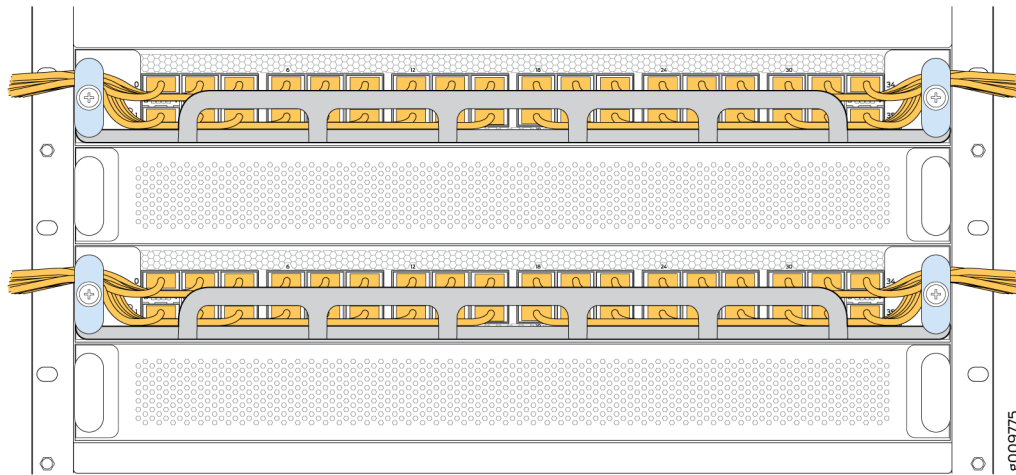


1- Handle extensions

2- Cable tray

Cables are draped across or under the handle extensions and then secured with cable wraps (see [Figure 21 on page 57](#)).

Figure 21: Two Cable Management Systems Installed on PTX10008



SEE ALSO

[Install the PTX10008 Cable Management System | 439](#)

PTX10008 Cooling System

IN THIS SECTION

- [PTX10008 Cooling System and Airflow | 58](#)
- [PTX10008 Fan Tray LEDs and Fan Tray Controller LEDs | 68](#)

The PTX10008 cooling system components work together to keep all components within the acceptable temperature range. If the maximum temperature specification is exceeded and the system cannot be adequately cooled, the Routing and Control Board shuts down some or all of the hardware components.

PTX10008 Cooling System and Airflow

IN THIS SECTION

- Fan Trays | 58
- Fan Tray Controllers | 62
- Airflow Direction in the PTX10008 | 66

The cooling system in a PTX10008 chassis consists of dual fan trays with matching dual fan tray controllers.

Two fan tray models (JNP10008-FAN, JNP10008-FAN2) and their associated fan tray controllers (JNP10008-FAN-CTRL, JNP10008-FTC2) are available and operate in systems with either the JNP10008-SF switch fabric or the JNP10008-SF3 switch fabric. Each fan tray requires a companion fan controller to be installed and operational to be hot-insertable and hot-removable. When upgrading from a JNP10008-FAN and JNP10008-FAN-CTRL system to a JNP10008-FAN2 and JNP10008-FTC2 system, be sure to upgrade the power supplies to JNP10K-PWR-AC2 or JNP10K-PWR-DC2 to ensure adequate airflow.

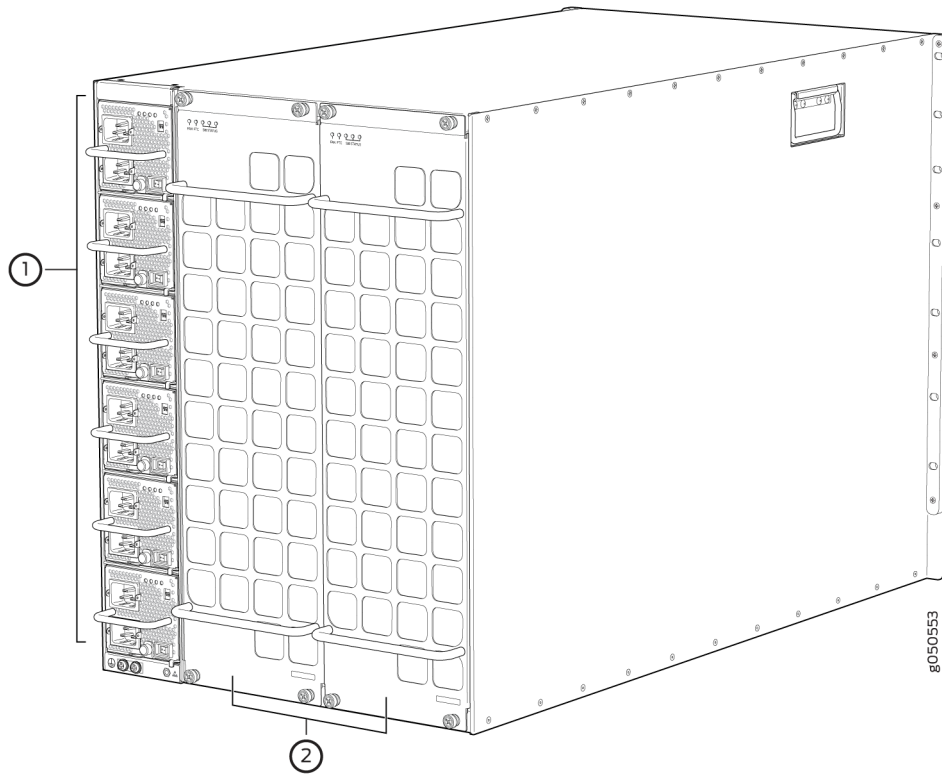
All power supplies installed in the routers have internal fans that contribute to chassis cooling. The JNP10K-PWR-AC3, JNP10K-PWR-AC2, and JNP10K-PWR-DC2 power supplies play a more substantial role in cooling the chassis than the JNP10K-PWR-AC and JNP10K-PWR-DC models. Therefore, all the JNP10K-PWR-AC2 or JNP10K-PWR-DC2 power supplies must be present in a running chassis to have the adequate airflow. While all power supplies are required to be present in the chassis, they do not necessarily be connected to power. If a power supply is installed in a slot but not connected to a power source, it draws power from the chassis to power the internal fans in the power supplies.

Fan Trays

Both fan tray models contain an array of internal fans, a non-removable control board, and LEDs.

The two fan trays install vertically, side by side, next to the power supplies on the FRU side of the chassis. Two handles on each front faceplate facilitate handling of the fan tray. See [Figure 22 on page 59](#) and [Figure 23 on page 60](#).

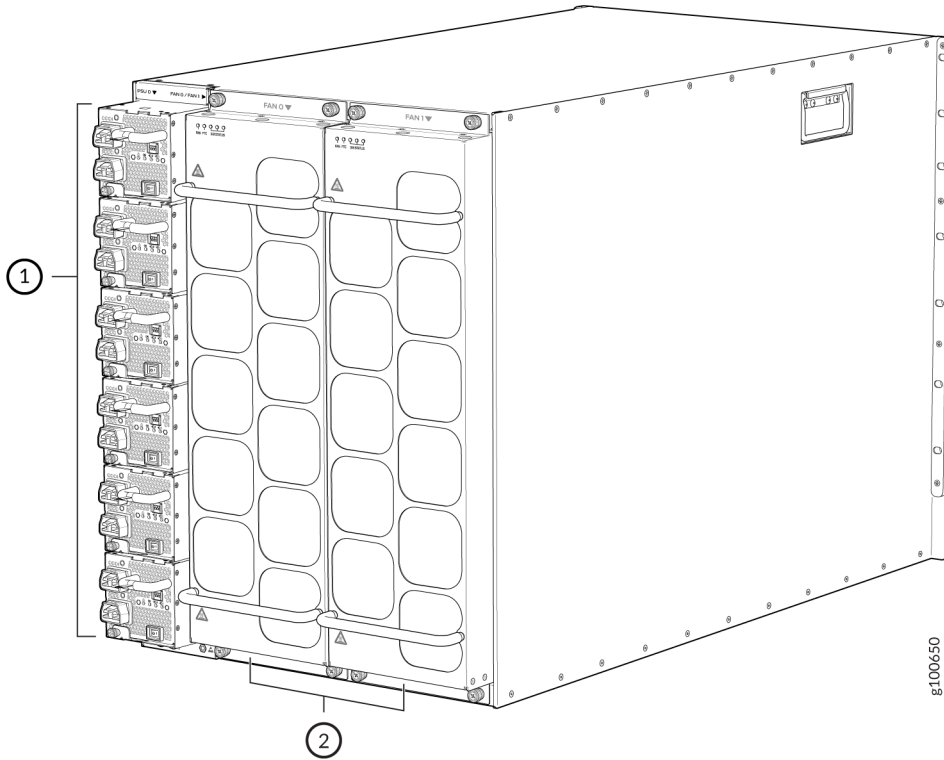
Figure 22: JNP10008-FAN Installed in a PTX10008 Router



1- Power supplies

2- Fan trays

Figure 23: JNP10008-FAN2 Installed in a PTX10008 Router



1– Power supplies

2– Fan trays

See [Table 11 on page 60](#) for the physical specifications for the fan trays.

Table 11: Fan Tray Specifications

Specification	JNP10008-FAN	JNP10008-FAN2
Corresponding fan tray controller model	JNP10008-FAN-CTRL	JNP10008-FTC2
Number of fans per fan tray	11	22
Number of fans per chassis	22	44
Fan numbering	0 through 10	0 through 21
Volume flow per fan tray at 100% at 72° F	720 cubic feet per minute (CFM)	920 CFM

Table 11: Fan Tray Specifications (Continued)

Specification	JNP10008-FAN	JNP10008-FAN2
Volume flow per chassis at 100% at 72° F	1580 CFM	2050 CFM
Switch fabric compatibility	JNP10008-SF	JNP10008-SF or JNP10008-SF3
Introduced in Junos OS Release	15.1X53-D30	19.2R1-S1
Height	22.4 in. (56.9 cm)	22.4 in. (56.9 cm)
Width	6.6 in. (16.8 cm)	6.6 in. (16.8 cm)
Depth	4.0 in. (10.2 cm) without handles, 5.2 in. (13.2 cm) with handles	5.5 in. (13.97 cm) without handles, 6.7 in. (17.01 cm) with handles
Weight	11.8 lb (5.4 kg)	20 lb (9.07 kg)

The array of fans in both models operate as a single unit. If an individual fan in the array fails, the entire fan tray must be replaced.

If you want to replace an existing fan tray while the router is running, remove only one fan tray. The router continues to operate for a limited time with a single operating fan tray without triggering a thermal alarm.



CAUTION: To avoid a thermal alarm, do not remove both fan trays while the router is operating.



CAUTION: The chassis will shut down if a thermal alarm is raised for more than three minutes.

The internal fan control board in each fan tray contains the LEDs for the associated fan tray controllers and the LEDs for the three SIBs directly behind the fan tray.

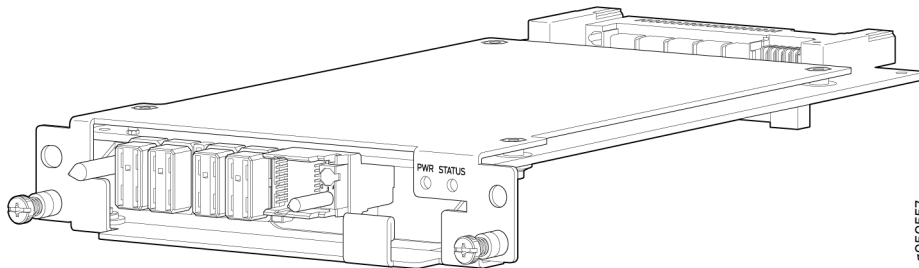
Fan Tray Controllers

The two fan tray controllers provide the control logic and power to hot-insert and hot-remove a fan tray.

There are two fan tray controller models:

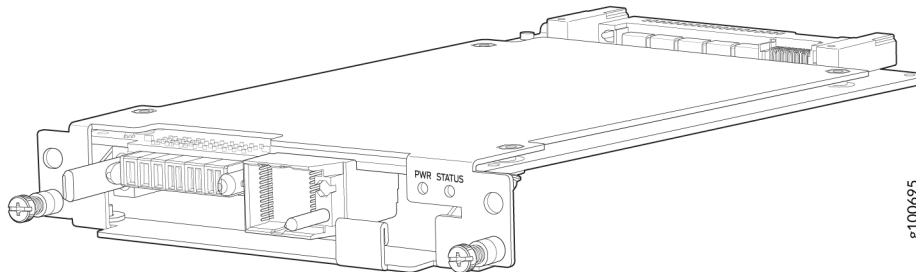
- JNP10008-FAN-CTRL—Supports model JNP10008-FAN; see [Figure 24 on page 62](#).

Figure 24: Fan Tray Controller JNP10008-FAN-CTRL



- JNP10008-FTC2—Supports model JNP10008-FAN2; see [Figure 25 on page 62](#).

Figure 25: Fan Controller JNP10008-FTC2



WARNING: Do not mix the fan tray controller models. Use only the supported fan tray model for each fan tray controller. See [Table 12 on page 63](#).

Table 12: Fan Tray Controller Specifications

Specification	JNP10008-FAN-CTRL	JNP10008-FTC2
Corresponding fan tray model	JNP10008-FAN	JNP10008-FAN2
Switch fabric compatibility	JNP10008-SF	JNP10008-SF or JNP10008-SF3
Introduced in Junos OS Release	15.1X53-D30	19.2R1
Height	1.5 in. (3.81 cm)	1.5 in. (3.81 cm)
Width	6.5 in. (15.24 cm)	6.5 in. (15.24 cm)
Depth	9.3 in. (23.62 cm)	9.4 in. (23.88 cm)
Weight	1.5 lb (0.68 kg)	1.1 lb (0.5 kg)

The system continually monitors the temperature of critical parts across the chassis and adjusts the chassis fan speed according to the temperature.

Junos OS software controls the fan speed. Under normal operating conditions, the fans in the fan tray run at less than full speed. If one fan tray controller fails or appears missing (such as when a SIB is being replaced), the other fan tray controller sets the fans to full speed. This allows the router to continue to operate normally as long as the remaining fans cool the chassis sufficiently. Use the `show chassis fan` command to see the status of individual fans and fan speed. The following examples of the `show chassis fan` command show the fan status for a system running JNP10008-FAN and JNP10008-FAN-CTRL:

1. This example shows the output from a JNP10008-SF fabric system running JNP10008-FAN and JNP10008-FAN-CTRL and standard Junos OS.

```

user@system> show chassis fan
  Item                Status  RPM    Measurement
  Fan Tray 0 Fan 0    OK      6300   Spinning at normal speed
  Fan Tray 0 Fan 1    OK      6150   Spinning at normal speed
  Fan Tray 0 Fan 2    OK      6300   Spinning at normal speed
  Fan Tray 0 Fan 3    OK      6300   Spinning at normal speed
  Fan Tray 0 Fan 4    OK      6150   Spinning at normal speed
  Fan Tray 0 Fan 5    OK      6000   Spinning at normal speed

```

```

Fan Tray 0 Fan 6      OK      6150   Spinning at normal speed
Fan Tray 0 Fan 7      OK      6150   Spinning at normal speed
Fan Tray 0 Fan 8      OK      6150   Spinning at normal speed
Fan Tray 0 Fan 9      OK      6300   Spinning at normal speed
Fan Tray 0 Fan 10     OK      6300   Spinning at normal speed
Fan Tray 1 Fan 0      OK      6300   Spinning at normal speed
Fan Tray 1 Fan 1      OK      6150   Spinning at normal speed
Fan Tray 1 Fan 2      OK      6300   Spinning at normal speed
Fan Tray 1 Fan 3      OK      6150   Spinning at normal speed
Fan Tray 1 Fan 4      OK      6300   Spinning at normal speed
Fan Tray 1 Fan 5      OK      6300   Spinning at normal speed
Fan Tray 1 Fan 6      OK      6150   Spinning at normal speed
Fan Tray 1 Fan 7      OK      6150   Spinning at normal speed
Fan Tray 1 Fan 8      OK      6150   Spinning at normal speed
Fan Tray 1 Fan 9      OK      6150   Spinning at normal speed
Fan Tray 1 Fan 10     OK      6300   Spinning at normal speed

```

2. This example shows the output from a JNP10008-SF3 fabric system running JNP10008-FAN2 and JNP10008-FTC2 and standard Junos OS.

```

user@system> show chassis fan

```

Item	Status	RPM	Measurement
Fan Tray 0 Fan 0	OK	6450	Spinning at normal speed
Fan Tray 0 Fan 1	OK	7950	Spinning at normal speed
Fan Tray 0 Fan 2	OK	6450	Spinning at normal speed
Fan Tray 0 Fan 3	OK	7950	Spinning at normal speed
Fan Tray 0 Fan 4	OK	6450	Spinning at normal speed
Fan Tray 0 Fan 5	OK	7950	Spinning at normal speed
Fan Tray 0 Fan 6	OK	6600	Spinning at normal speed
Fan Tray 0 Fan 7	OK	7950	Spinning at normal speed
Fan Tray 0 Fan 8	OK	6450	Spinning at normal speed
Fan Tray 0 Fan 9	OK	7800	Spinning at normal speed
Fan Tray 0 Fan 10	OK	6450	Spinning at normal speed
Fan Tray 0 Fan 11	OK	7950	Spinning at normal speed
Fan Tray 0 Fan 12	OK	6450	Spinning at normal speed
Fan Tray 0 Fan 13	OK	7800	Spinning at normal speed
Fan Tray 0 Fan 14	OK	6450	Spinning at normal speed
Fan Tray 0 Fan 15	OK	7800	Spinning at normal speed
Fan Tray 0 Fan 16	OK	6450	Spinning at normal speed
Fan Tray 0 Fan 17	OK	7950	Spinning at normal speed
Fan Tray 0 Fan 18	OK	6450	Spinning at normal speed

```

Fan Tray 0 Fan 19      OK      7800   Spinning at normal speed
Fan Tray 0 Fan 20      OK      6300   Spinning at normal speed
Fan Tray 0 Fan 21      OK      7800   Spinning at normal speed
Fan Tray 1 Fan 0       OK      6450   Spinning at normal speed
Fan Tray 1 Fan 1       OK      7950   Spinning at normal speed
Fan Tray 1 Fan 2       OK      6600   Spinning at normal speed
Fan Tray 1 Fan 3       OK      7950   Spinning at normal speed
Fan Tray 1 Fan 4       OK      6600   Spinning at normal speed
Fan Tray 1 Fan 5       OK      7950   Spinning at normal speed
Fan Tray 1 Fan 6       OK      6600   Spinning at normal speed
Fan Tray 1 Fan 7       OK      7950   Spinning at normal speed
Fan Tray 1 Fan 8       OK      6600   Spinning at normal speed
Fan Tray 1 Fan 9       OK      7950   Spinning at normal speed
Fan Tray 1 Fan 10      OK      6450   Spinning at normal speed
Fan Tray 1 Fan 11      OK      7950   Spinning at normal speed
Fan Tray 1 Fan 12      OK      6450   Spinning at normal speed
Fan Tray 1 Fan 13      OK      7800   Spinning at normal speed
Fan Tray 1 Fan 14      OK      6450   Spinning at normal speed
Fan Tray 1 Fan 15      OK      7800   Spinning at normal speed
Fan Tray 1 Fan 16      OK      6450   Spinning at normal speed
Fan Tray 1 Fan 17      OK      7950   Spinning at normal speed
Fan Tray 1 Fan 18      OK      6450   Spinning at normal speed
Fan Tray 1 Fan 19      OK      7800   Spinning at normal speed
Fan Tray 1 Fan 20      OK      6450   Spinning at normal speed
Fan Tray 1 Fan 21      OK      7650   Spinning at normal speed

```

3. This example shows the output from a JNP10008-SF3 fabric system running JNP10008-FAN2 and JNP10008-FTC2 and Junos OS Evolved.

```

user@system> show chassis fan

```

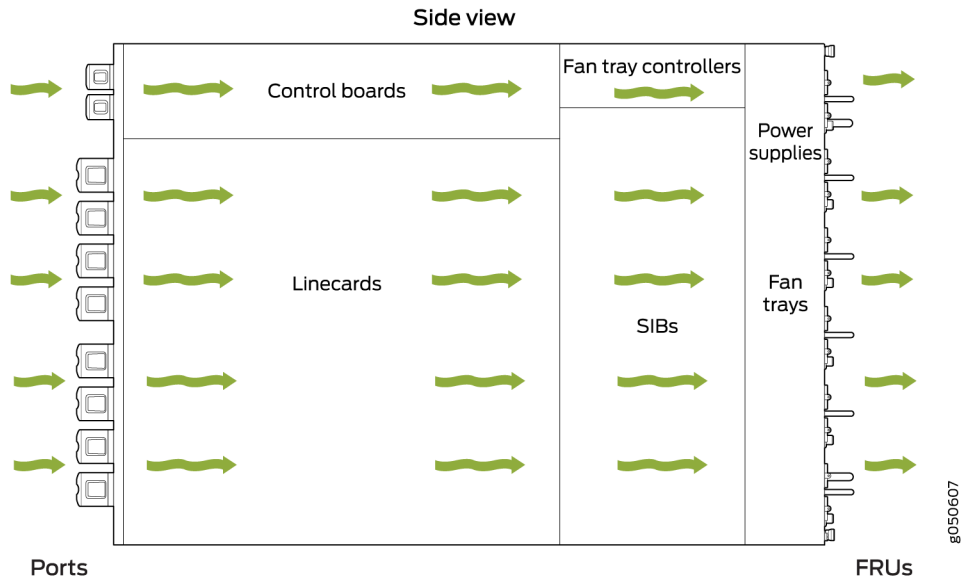
Item	Status	% RPM	Measurement
Fan Tray 0 Fan 0	Ok	83%	8850 RPM
Fan Tray 0 Fan 1	Ok	75%	10200 RPM
Fan Tray 0 Fan 2	Ok	83%	8850 RPM
Fan Tray 0 Fan 3	Ok	76%	10350 RPM
Fan Tray 0 Fan 4	Ok	83%	8850 RPM
Fan Tray 0 Fan 5	Ok	76%	10350 RPM
Fan Tray 0 Fan 6	Ok	83%	8850 RPM
Fan Tray 0 Fan 7	Ok	75%	10200 RPM
Fan Tray 0 Fan 8	Ok	83%	8850 RPM
Fan Tray 0 Fan 9	Ok	76%	10350 RPM
Fan Tray 0 Fan 10	Ok	83%	8850 RPM

Fan Tray 0 Fan 11	Ok	75%	10200 RPM
Fan Tray 0 Fan 12	Ok	84%	9000 RPM
Fan Tray 0 Fan 13	Ok	75%	10200 RPM
Fan Tray 0 Fan 14	Ok	81%	8700 RPM
Fan Tray 0 Fan 15	Ok	75%	10200 RPM
Fan Tray 0 Fan 16	Ok	83%	8850 RPM
Fan Tray 0 Fan 17	Ok	75%	10200 RPM
Fan Tray 0 Fan 18	Ok	83%	8850 RPM
Fan Tray 0 Fan 19	Ok	74%	10050 RPM
Fan Tray 0 Fan 20	Ok	81%	8700 RPM
Fan Tray 0 Fan 21	Ok	75%	10200 RPM
Fan Tray 1 Fan 0	Ok	83%	8850 RPM
Fan Tray 1 Fan 1	Ok	75%	10200 RPM
Fan Tray 1 Fan 2	Ok	83%	8850 RPM
Fan Tray 1 Fan 3	Ok	76%	10350 RPM
Fan Tray 1 Fan 4	Ok	83%	8850 RPM
Fan Tray 1 Fan 5	Ok	76%	10350 RPM
Fan Tray 1 Fan 6	Ok	84%	9000 RPM
Fan Tray 1 Fan 7	Ok	76%	10350 RPM
Fan Tray 1 Fan 8	Ok	83%	8850 RPM
Fan Tray 1 Fan 9	Ok	75%	10200 RPM
Fan Tray 1 Fan 10	Ok	83%	8850 RPM
Fan Tray 1 Fan 11	Ok	75%	10200 RPM
Fan Tray 1 Fan 12	Ok	81%	8700 RPM
Fan Tray 1 Fan 13	Ok	75%	10200 RPM
Fan Tray 1 Fan 14	Ok	83%	8850 RPM
Fan Tray 1 Fan 15	Ok	75%	10200 RPM
Fan Tray 1 Fan 16	Ok	83%	8850 RPM
Fan Tray 1 Fan 17	Ok	75%	10200 RPM
Fan Tray 1 Fan 18	Ok	83%	8850 RPM
Fan Tray 1 Fan 19	Ok	76%	10350 RPM
Fan Tray 1 Fan 20	Ok	81%	8700 RPM
Fan Tray 1 Fan 21	Ok	74%	10050 RPM

Airflow Direction in the PTX10008

The air intake to cool the chassis is located on the port (line card) side of the chassis. Air flows into the chassis from the ports in the RCBs and line cards, through the Switch Interface Boards (SIBs), and exits from the fan trays and the power supplies. See [Figure 26 on page 67](#).

Figure 26: Airflow Through a PTX10008



The fan tray continues to operate indefinitely and provide sufficient cooling even when a single fan fails, provided the room temperature is within the operating range. You can check the status of fans by viewing the LEDs on each fan tray. See ["PTX10008 Fan Tray LEDs and Fan Tray Controller LEDs"](#) on page 68.

You cannot replace a single fan. If one or more fans fail, you must replace the entire fan tray.

In addition to the fans in the fan trays, there is an internal fan in each power supply that also helps to cool components, such as the line cards.

SEE ALSO

[PTX10008 Field-Replaceable Units | 49](#)

[Install a PTX10008 Fan Tray | 348](#)

[Remove a PTX10008 Fan Tray | 351](#)

PTX10008 Fan Tray LEDs and Fan Tray Controller LEDs

IN THIS SECTION

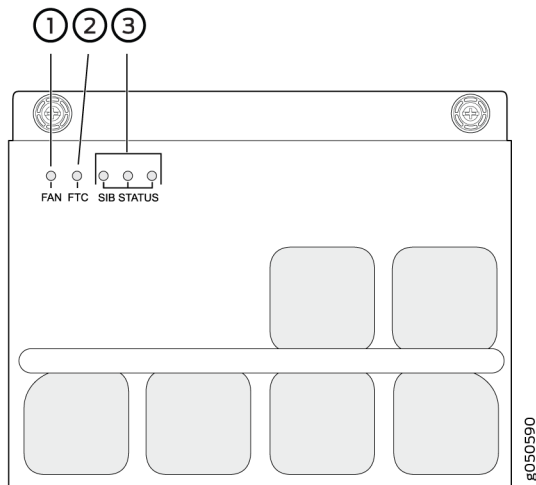
- Fan Tray LEDs | 68
- Fan Tray Controller LEDs | 73

Each fan tray has a set of LEDs, and each corresponding fan tray controller also has a set of LEDs.

Fan Tray LEDs

Each fan tray has a set of LEDs that represent the status of the fans in the fan tray, the fan tray controller, and the three Switch Interface Boards (SIBs). The fan tray LEDs are located in the top left corner of each fan tray. [Figure 27 on page 68](#) shows the location of the LEDs on JNP10008-FAN fan trays. See [Figure 28 on page 69](#) for the location of LEDs on the JNP10008-FAN2 fan trays.

Figure 27: Fan Tray JNP10008-FAN LEDs

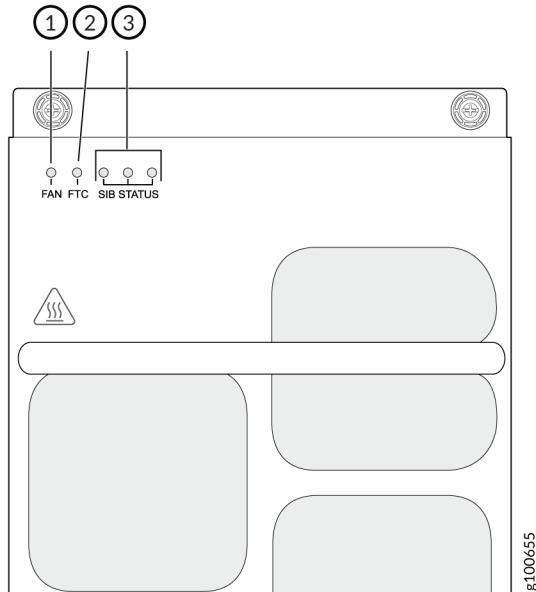


1- Fan status LED

2- Fan tray controller status LED

3- SIB status LEDs (SIB 0 through SIB 2 for the left fan tray and SIB 3 through SIB 5 for the right fan tray)

Figure 28: Fan Tray JNP10008-FAN2 LEDs



1– Fan status LED

3– SIB status LEDs (SIB 0 through SIB 2 for the left fan tray and SIB 3 through SIB 5 for the right fan tray).

2– Fan tray controller status LED

Table 13 on page 69 describes the functions of the fan tray LEDs.

Table 13: Fan Tray LEDs on a PTX10008 Router

Name	Color	State	Description
FAN (fan status)	Green	On steadily	All fans are operating normally. The system has verified that the fan tray is engaged, that the airflow is in the correct direction, and that all fans are operating correctly.

Table 13: Fan Tray LEDs on a PTX10008 Router *(Continued)*

Name	Color	State	Description
	Yellow	Blinking	An error has been detected in one or more fans in the fan tray. Replace the fan tray as soon as possible. Either the fan has failed or it has become disconnected. To maintain proper airflow through the chassis, leave the fan tray installed in the chassis until you are ready to replace it.
	None	Off	The fan is not receiving power from the fan tray controller.
FTC (fan tray controller status)	Green	On steadily	The fan tray controller is online and is operating normally.
	Yellow	Blinking	An error has been detected in the fan tray controller. Replace the fan tray controller as soon as possible. The fan tray controller is located behind the fan tray above the SIBs. To maintain proper airflow through the chassis, leave the fan tray installed in the chassis until you are ready to replace the fan tray controller.
	None	Off	The fan tray controller is not receiving power.
SIB Status (SIB 0 status)	Green	On steadily	The left-most SIB in the chassis is online.

Table 13: Fan Tray LEDs on a PTX10008 Router *(Continued)*

Name	Color	State	Description
	Yellow	Blinking	An error has been detected in SIB 0. Replace the SIB as soon as possible. The SIB is located behind the left fan tray and is the left-most SIB in the chassis. To maintain proper airflow through the chassis, leave the fan tray installed in the chassis until you are ready to replace the SIB.
	None	Off	The SIB is offline.
SIB Status (SIB 1 status)	Green	On steadily	The center SIB behind the left fan tray is online.
	Yellow	Blinking	An error has been detected in SIB 1. Replace the SIB as soon as possible. The SIB is located behind the left fan tray and is the middle SIB in the group of 3. To maintain proper airflow through the chassis, leave the fan tray installed in the chassis until you are ready to replace the SIB.
	None	Off	The SIB is offline.
SIB Status (SIB 2 status)	Green	On steadily	The right-most SIB behind the left fan tray is online.
	Yellow	Blinking	An error has been detected in SIB 2. Replace the SIB as soon as possible. The SIB is located behind the left fan tray and is the right-most SIB in the group of 3. To maintain proper airflow through the chassis, leave the fan tray installed in the chassis until you are ready to replace the SIB.

Table 13: Fan Tray LEDs on a PTX10008 Router (Continued)

Name	Color	State	Description
	None	Off	The SIB is offline.
SIB Status (SIB 3 status)	Green	On steadily	The left-most SIB behind the right fan tray is online.
	Yellow	Blinking	An error has been detected in SIB 3. Replace the SIB as soon as possible. The SIB is located behind the right fan tray and is the left-most SIB in the group of 3. To maintain proper airflow through the chassis, leave the fan tray installed in the chassis until you are ready to replace the SIB.
	None	Off	The SIB is offline.
SIB Status (SIB 4 status)	Green	On steadily	The center SIB behind the right fan tray is online.
	Yellow	Blinking	An error has been detected in SIB 4. Replace the SIB as soon as possible. The SIB is located behind the right fan tray and is the middle SIB in the group of 3. To maintain proper airflow through the chassis, leave the fan tray installed in the chassis until you are ready to replace the SIB.
	None	Off	The SIB is offline.
SIB Status (SIB 5 status)	Green	On steadily	The right-most SIB behind the right fan tray is online.

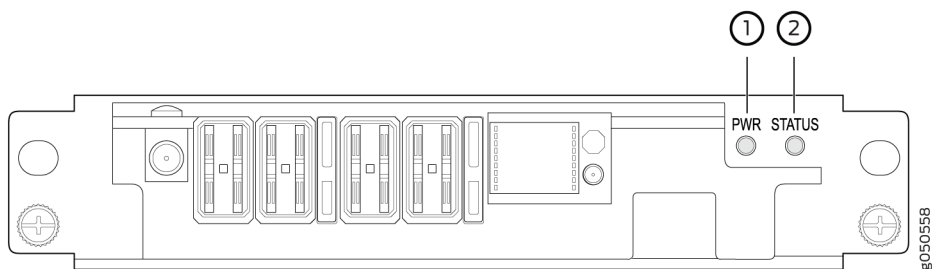
Table 13: Fan Tray LEDs on a PTX10008 Router (Continued)

Name	Color	State	Description
	Yellow	Blinking	An error has been detected in SIB 5. Replace the SIB as soon as possible. The SIB is located behind the right fan tray and is the right-most SIB in the group of 3. To maintain proper airflow through the chassis, leave the fan tray installed in the chassis until you are ready to replace the SIB.
	None	Off	The SIB is offline.

Fan Tray Controller LEDs

All models of fan tray controller have the same LEDs. The fan tray controller LEDs are visible only when the associated fan tray is removed. The fan tray controller LEDs are located on the right of the controller panel. [Figure 29 on page 73](#) shows the location of the LEDs on the JNP10008-FAN-CTRL or the JNP10008-FTC2 fan tray controller faceplate.

Figure 29: Fan Tray Controller LEDs on a PTX10008



1– Fan tray controller power

2– Fan tray controller status

[Table 14 on page 74](#) describes the functions of the fan tray controller LEDs.

Table 14: Fan Tray Controller LEDs on a PTX10008

Name	Color	State	Description
PWR (fan tray controller power)	Green	On steadily	The fan tray controller has power and is operating normally.
	Yellow	Blinking	A power error has been detected in the fan tray controller. Replace the fan tray controller as soon as possible. To maintain proper airflow through the chassis, leave the fan tray installed in the chassis until you are ready to replace the fan tray controller.
	None	Off	The fan tray controller is not powered on or is not receiving power.
STATUS (fan tray controller status)	Green	On steadily	The fan tray controller is online and is operating normally.
	Yellow	Blinking	An error has been detected in the fan tray controller. Replace the fan tray controller as soon as possible. To maintain proper airflow through the chassis, leave the fan tray installed in the chassis until you are ready to replace the fan tray controller.
	None	Off	The fan tray controller is not receiving power.

SEE ALSO

[Install a PTX10008 Fan Tray | 348](#)

[Remove a PTX10008 Fan Tray | 351](#)

[Install a PTX10008 Fan Tray Controller | 355](#)

[Remove a PTX10008 Fan Tray Controller | 358](#)

PTX10008 Power System

IN THIS SECTION

- [JNP10K-PWR-AC Power Supply | 76](#)
- [JNP10K-PWR-AC2 Power Supply | 78](#)
- [JNP10K-PWR-AC3 Power Supply | 81](#)
- [JNP10K-PWR-DC Power Supply | 86](#)
- [JNP10K-PWR-DC2 Power Supply | 88](#)
- [JNP10K-PWR-AC Power Supply LEDs | 90](#)
- [JNP10K-PWR-AC2 Power Supply LEDs | 92](#)
- [JNP10K-PWR-AC3 Power Supply LEDs | 94](#)
- [JNP10K-PWR-DC Power Supply LEDs | 97](#)
- [JNP10K-PWR-DC2 Power Supply LEDs | 100](#)

PTX10008 routers support AC, DC, high-voltage alternating current (HVAC), and high-voltage direct current (HVDC) by offering the following power supplies:

- JNP10K-PWR-AC
- JNP10K-PWR-AC2
- JNP10K-PWR-AC3
- JNP10K-PWR-DC
- JNP10K-PWR-DC2

You can install up to six power supplies in a PTX10008 router in the slots labeled **PEM 0** through **PEM 5** (top to bottom) located in the rear of the chassis. All models of the power supply operate in JNP10008-SF fabric systems. The JNP10008-SF3 switch fabric requires the JNP10K-PWR-AC2 or the JNP10K-PWR-DC2 power supply.

The JNP10K-PWR-AC2 and JNP10K-PWR-DC2 power supplies share power. The JNP10K-PWR-AC and JNP10K-PWR-DC power supplies do not share power.

NOTE: The JNP10K-PWR-AC2 and JNP10K-PWR-AC3 can share power proportionally in a mixed configuration, only when you are upgrading to JNP10K-PWR-AC3.

JNP10K-PWR-AC Power Supply

The JNP10K-PWR-AC power supplies are 2700-W and support 200–240 VAC. The output power is 2700 W.



CAUTION: Do not mix AC and DC power supplies in the same chassis. AC and HVAC can coexist in the same chassis during the hot swap of AC for HVAC. Do not mix AC and HVAC power supplies in a running environment.



WARNING: The router is pluggable type A equipment installed in a restricted-access location. It has a separate protective earthing terminal on the chassis that must be connected to earth ground permanently to ground the chassis adequately and protect the operator from electrical hazards.



CAUTION: Before you begin installing the router, ensure that a licensed electrician has attached an appropriate grounding lug to the grounding cable that you supply. Using a grounding cable with an incorrectly attached lug can damage the router.



CAUTION: You can prevent AC power cables from being exposed to hot air exhaust by always routing the power cables away from the fan trays and power supplies.

Each JNP10K-PWR-AC power supply has two independent 16-A rated AC inlets on the faceplate. Though each inlet provides sufficient input power to provide full output, always connect to a dedicated AC power feed to provide redundancy. Only one power feed is operational at a time.

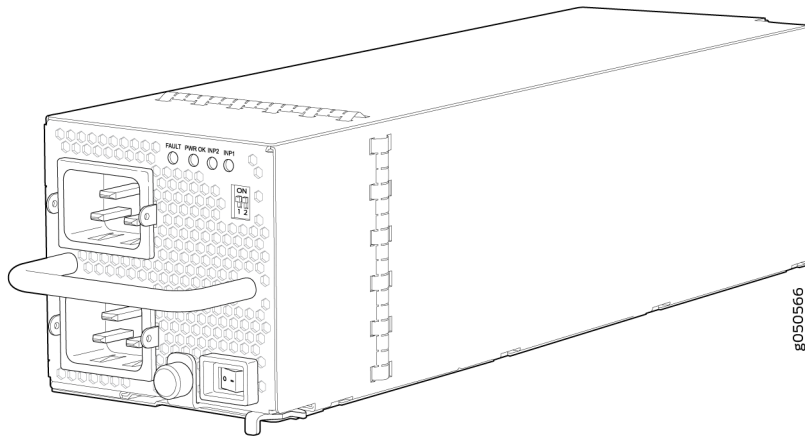
NOTE: For redundancy, always plug the two power cords from each power supply:

- **INP1** into the public electricity supply

- **INP2** into an alternative or independent power source

Each JNP10K-PWR-AC power supply has a power switch with international markings for on (I) and off (O), a fan, and four LEDs on the faceplate that indicate the status of the power supply. It also has a set of dual inline package (DIP) switches that enable the source feeds, **INP1** and **INP2**. See [Figure 30 on page 77](#).

Figure 30: JNP10K-PWR-AC Power Supply

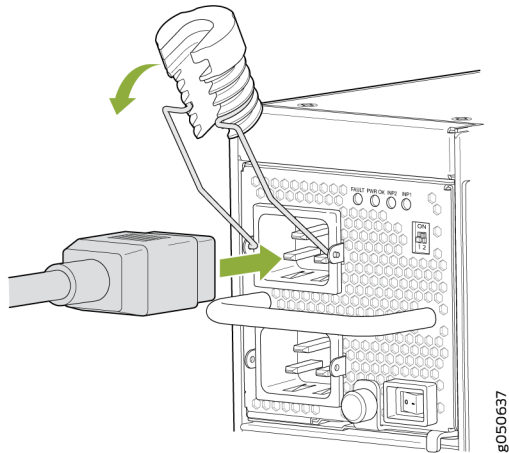


CAUTION: Use a dedicated overcurrent protection device that meets the site's local laws and standard.

Each JNP10K-PWR-AC power supply comes with two power cord retainers that hold the power cords in place. See [Figure 31 on page 78](#). Each power cord retainer has a clip and an adjustment nut. The ends of the clip hook into the bracket holes on each side of the AC appliance inlet on the faceplate. The adjustment nut holds the power cord in the correct position.

NOTE: Route all the AC power supply cords away from the fan trays and power supply vents. Make sure that the power cords do not obstruct the fan trays or power supply vents.

Figure 31: Power Cord Retainer for a JNP10K-PWR-AC Power Supply



Each power supply connects to the power rail in the router. The power rail distributes the output power produced by the power supplies to different router components. Each power supply provides power to all the components in the router.

Each power supply has its own fan and is cooled by its own internal cooling system. Hot air exhausts from the rear of the chassis.

SEE ALSO

[JNP10K-PWR-AC Power Specifications | 219](#)

[Install a JNP10K-PWR-AC Power Supply | 362](#)

[Remove a JNP10K-PWR-AC Power Supply | 369](#)

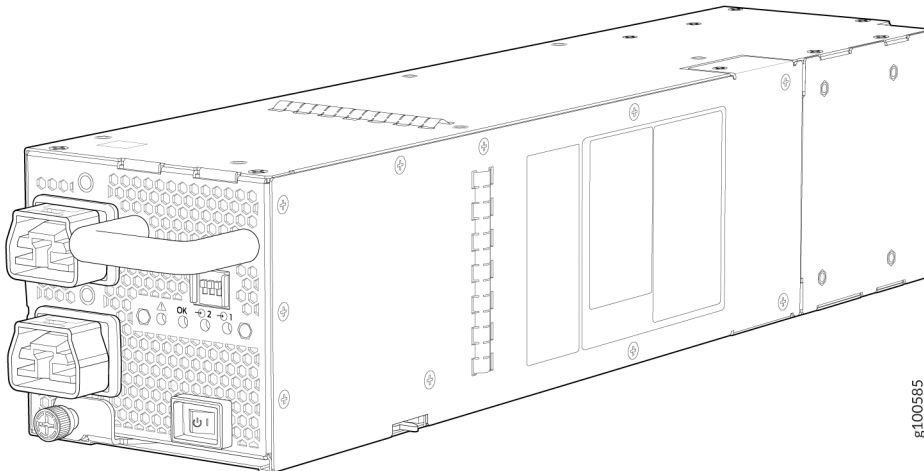
JNP10K-PWR-AC2 Power Supply

The JNP10K-PWR-AC2 power supply is a high-capacity model that is designed to support AC, high-voltage AC (HVAC), or high-voltage DC (HVDC) systems in either a 20-A or a 30-A mode; see [Figure 32 on page 79](#). The power supply feeds AC input and provides DC output of 5000 W with a single feed and 5500 W with a dual feed. The operating input voltage range is 180 to 305 VAC for AC systems and 190 to 410 VDC for DC systems.

The number of power feeds and whether the power supplies provide high-output (30-A) or low-output (20-A) power are configured using a set of dual in line package (DIP) switches on the faceplate of the power supply. If one power supply in the chassis is set to low power, the power budget for the chassis is reduced to low power, regardless of their DIP switch settings or the output results in the CLI. This

design safeguards against accidentally setting the power supply to 30 A in a facility that can provide only 20 A and tripping the facility circuit breaker. We recommend that you don't mix DIP switch settings in your system. See [Table 15 on page 80](#) for information about the input and output voltages when you use the DIP switches.

Figure 32: JNP10K-PWR-AC2 Power Supply



WARNING: Extreme burn danger—Do not handle an HVAC or HVDC power supply running in the chassis without heat protective gloves. The JNP10K-PWR-AC2 can reach temperatures in the range of 158°F to 176°F (70°C to 80°C) under running conditions.



WARNING: The router is pluggable type A equipment installed in a restricted-access location. It has a separate protective earthing terminal on the chassis that must be connected to earth ground permanently to ground the chassis adequately and protect the operator from electrical hazards.



CAUTION: Before you begin installing the router, ensure that a licensed electrician has attached an appropriate grounding lug to the grounding cable that you supply. Using a grounding cable with an incorrectly attached lug can damage the router.



CAUTION: Use a dedicated overcurrent protection device that meets the site's local laws and standard.

Table 15: DIP Switch Settings for JNP10K-PWR-AC2 Power Supplies

INP0—PS 0 (DIP Switch 1)	INP1—PS 1 (DIP Switch 2)	H/L (High Input 30 A/ Low Input 20 A)	Output Power
On	On	On (30 A)	5500 W
On	On	Off (20 A)	3000 W
On	Off	On (30 A)	5000 W
Off	On	On (30 A)	5000 W
On	Off	Off (20 A)	2700 W
Off	On	Off (20 A)	2700 W

NOTE: If one of the DIP switches is in the on position and if the power switch is set to the off position, the system raises an alarm that the input feeds are missing. You can avoid this by setting both the DIP switches to off position.

NOTE:

- IP1
 - INP1 in the CLI output for Junos OS Evolved Release 20.4R2 or later.
 - INP0 in the CLI output for releases earlier than Junos OS Evolved Release 20.4R2.
- IP2
 - INP2 in the CLI output for Junos OS Evolved Release 20.4R2 or later.
 - INP1 in the CLI output for releases earlier than Junos OS Evolved Release 20.4R2.



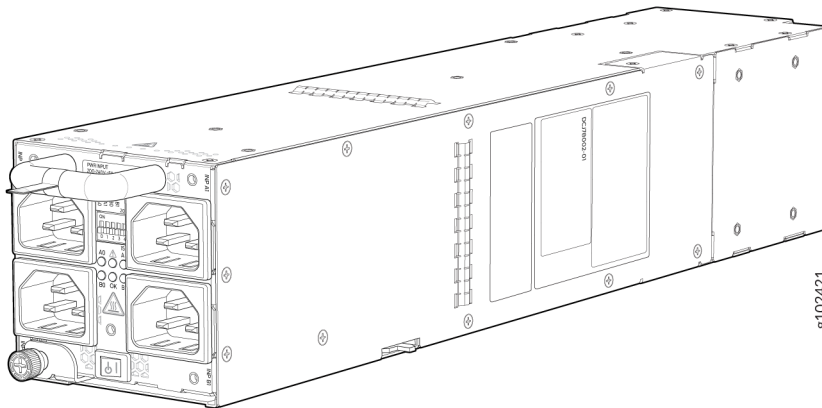
CAUTION: It is important to connect both input feeds of the JNP10K-PWR-AC2 power supply to AC mains before loading the system with power.

The power supplies have internal fans that contribute to chassis cooling. Therefore, all the power supplies must be present in a running chassis to have the adequate airflow. While all power supplies are required to be present in the chassis, they do not necessarily be connected to power. If a power supply is installed in a slot but is not connected to a power source, it draws power from the chassis to power the internal fans in the power supplies.

JNP10K-PWR-AC3 Power Supply

The JNP10K-PWR-AC3 power supply is a high-capacity model that is designed to support AC systems in a 15-A and 20-A mode; see [Figure 33 on page 81](#).

Figure 33: JNP10K-PWR-AC3 Power Supply



Input—The power supply takes four single-phase AC (180-264 VAC) inputs (A0, A1, B0, and B1) at either 20 A or 15 A and provides a DC output of 12.3V. The input receptacle on the AC power supply unit (PSU) is IEC 320-C22. The mating connector on the power cord is IEC 320-C21.

Output—The power supply provides DC output of 12.3V at:

- 7800 W (20-A input) with three or four active feeds, or
- 6000 W (20-A input) with two active feeds (either A0 and A1 or B0 and B1), or
- 3000 W (20-A input) with single active feed.
- 7800 W (15-A input) with four active feeds, or
- 7500 W (15-A input) with three active feeds, or

- 5000 W (15-A input) with two active feeds, or
- 2500 W (15-A input) with single active feed.
- The operating input voltage range is 180 to 264 VAC for AC systems. The DC output is 12.3 VDC.
- The number of power feeds and whether the power supplies provide high-output (20-A) or low-output (15-A) power are configured using a set of dual inline package (DIP) switches on the faceplate of the power supply. If one power supply in the chassis is set to low power, the power budget for the chassis is reduced to low power, regardless of their DIP switch settings or the output results in the CLI. This design safeguards against accidentally setting the power supply to 20 A in a facility that can provide only 15 A and tripping the facility circuit breaker. We recommend that you don't mix DIP switch settings in your system. See [Table 16 on page 84](#) for information about the input and output voltages when you use the DIP switches.
- The JNP10K-PWR-AC3 power supply has an ENABLE switch on the front panel to enable/disable the main 12.3 VDC output and +5.0 V_BIAS standby output as well. If the switch is in DISABLE position, the front-end PFC will be disabled to minimize power consumption. This switch has the highest priority over any other shutdown method.
- The Power Factor Correction (PFC) is PF 0.98 kW minimum at full load. The maximum inrush current is 50 A for the active feed.

JNP10K-PWR-BLN3 or Active Blank

Juniper Networks offers an Active Blank Power Module (ABPM), JNP10K-PWR-BLN3. This helps in airflow and cooling in the chassis.

- **NOTE:** A minimum of one JNP10K-PWR-AC3 power supply unit (PSU) must be present in the router chassis.

The JNP10K-PWR-AC3 power supply has internal fans that contribute to chassis cooling. Three PSUs or two PSUs along with a ABPM must be present in a running chassis to have the adequate airflow. While the minimum power supplies are required to be present in the chassis, they all need not be necessarily connected to power source. If a power supply is installed in a slot but not connected to a power source, it draws power from the chassis to power the internal fans in the power supplies.



WARNING: Extreme burn danger—The JNP10K-PWR-AC3 can reach temperatures in the range of 158° F to 176° F (70° C to 80° C) under running conditions.



WARNING: The router is pluggable type A equipment installed in a restricted-access location. It has a separate protective earthing terminal on the chassis that must be connected to earth ground permanently to ground the chassis adequately and protect the operator from electrical hazards.



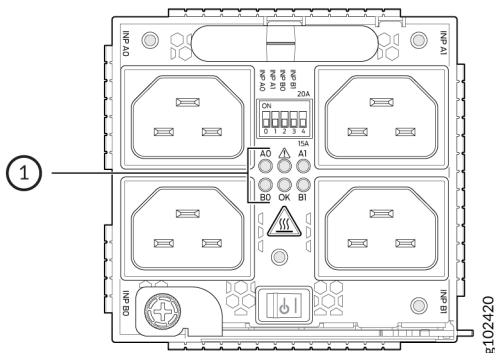
CAUTION: Before you begin installing the router, ensure that a licensed electrician has attached an appropriate grounding lug to the grounding cable that you supply. Using a grounding cable with an incorrectly attached lug can damage the router.



CAUTION: Use a dedicated overcurrent protection device that meets the site's local laws and standard.

The JNP10K-PWR-AC3 Power Supplies have five dual position DIP switches (INP-A0, INP-A1, INP-B0, INP-B1, and DIP4) that are accessible from the front panel. DIP4 is the fifth DIP switch, which is used to indicate whether 20A or 15A input source is connected. See [Figure 34 on page 83](#) and [Table 16 on page 84](#) to know the layout of the DIP switches and the power output when the DIP switches are set in different combinations.

Figure 34: DIP Switches on JNP10K-PWR-AC3 Power Supply



1—LEDs corresponding to the DIP switches above it.

Table 16: DIP Switch Settings for JNP10K-PWR-AC3 Power Supply

INP-A0 (Switch 0)	INP-A1 (Switch 1)	INP-B0 (Switch 2)	INP-B1 (Switch 3)	Switch 4 (High Input 20 A/ Low Input 15 A)	Output Power
15-A					
Off	Off	Off	On	Off (15 A)	2500 W
Off	Off	On	Off	Off (15 A)	2500 W
Off	Off	On	On	Off (15 A)	5000 W
Off	On	Off	Off	Off (15 A)	2500 W
Off	On	Off	On	Off (15 A)	5000 W
Off	On	On	On	Off (15 A)	7500 W
Off	On	On	Off	Off (15 A)	5000 W
On	Off	Off	Off	Off (15 A)	2500 W
On	Off	Off	On	Off (15 A)	5000 W
On	Off	On	Off	Off (15 A)	5000 W
On	Off	On	On	Off (15 A)	7500 W
On	On	Off	Off	Off (15 A)	5000 W
On	On	Off	On	Off (15 A)	7500 W
On	On	On	Off	Off (15 A)	7500 W

Table 16: DIP Switch Settings for JNP10K-PWR-AC3 Power Supply (Continued)

INP-A0 (Switch 0)	INP-A1 (Switch 1)	INP-B0 (Switch 2)	INP-B1 (Switch 3)	Switch 4 (High Input 20 A/ Low Input 15 A)	Output Power
On	On	On	On	Off (15 A)	7800 W
20-A					
Off	Off	Off	On	On (20 A)	3000 W
Off	Off	On	Off	On (20 A)	3000 W
Off	Off	On	On	On (20 A)	6000 W
Off	On	Off	Off	On (20 A)	3000 W
Off	On	Off	On	On (20 A)	6000 W
Off	On	On	Off	On (20 A)	6000 W
Off	On	On	On	On (20 A)	7800 W
On	Off	Off	Off	On (20 A)	3000 W
On	Off	Off	On	On (20 A)	6000 W
On	Off	On	Off	On (20 A)	6000 W
On	Off	On	On	On (20 A)	7800 W
On	On	Off	Off	On (20 A)	6000 W
On	On	Off	On	On (20 A)	7800 W

Table 16: DIP Switch Settings for JNP10K-PWR-AC3 Power Supply (Continued)

INP-A0 (Switch 0)	INP-A1 (Switch 1)	INP-B0 (Switch 2)	INP-B1 (Switch 3)	Switch 4 (High Input 20 A/ Low Input 15 A)	Output Power
On	On	On	Off	On (20 A)	7800 W
On	On	On	On	On (20 A)	7800 W



CAUTION: It is important to connect the input feeds of the JNP10K-PWR-AC3 power supply to AC mains before powering-on the router.

JNP10K-PWR-DC Power Supply

The DC power supply, JNP10K-PWR-DC, is a 2500-W, dual input power supply. The output power is 2500 W.



WARNING: The router is pluggable type A equipment installed in a restricted-access location. It has a separate protective earthing terminal on the chassis that must be connected to earth ground permanently to ground the chassis adequately and protect the operator from electrical hazards.



CAUTION: Before you begin installing the router, ensure that a licensed electrician has attached an appropriate grounding lug to the grounding cable that you supply. Using a grounding cable with an incorrectly attached lug can damage the router.

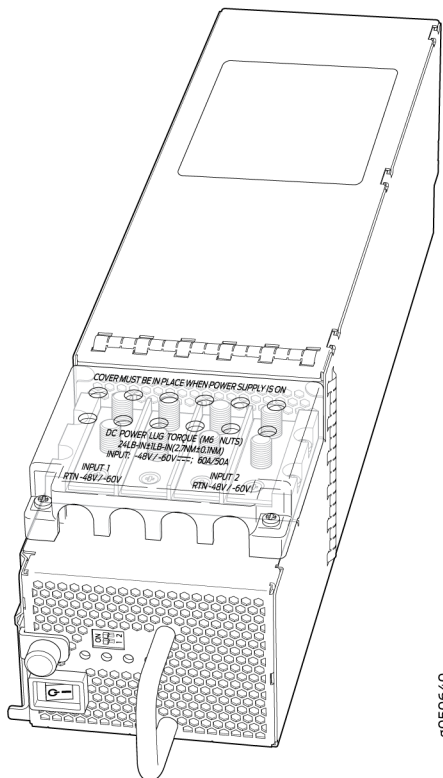
NOTE: DC power supplies are shipped only in the redundant configuration of PTX10008 routers.

Each JNP10K-PWR-DC power supply has two independent pairs of DC input lugs (**Input 1, RTN, -48V/-60V** and **Input 2, RTN, -48V/-60V**) on the faceplate of the power supply. Each inlet requires a dedicated DC power feed. Although each inlet provides sufficient input power to provide full output, always connect the power supply to a dedicated DC power feed to provide redundancy. Only one power feed is operational at a time.

DC power models employ electronic A-B input selection. Should one power source fail, electronic A-B input selection routes the power supply to the alternate source. The power supply internally balances power between source input A and source input B. The default is to balance 50% to each input.

Each JNP10K-PWR-DC power supply has a power switch with international markings for on (I) and off (O), a built-in fan, and four LEDs on the faceplate that indicate the status of the power supply. See [Figure 35 on page 87](#).

Figure 35: JNP10K-PWR-DC Power Supply



8050640

NOTE: The JNP10K-PWR-DC power supply requires a dedicated circuit breaker for each input DC feed. The chosen breaker should be sized to deliver 60 A of input current.

Each power supply connects to the combined power rail in a PTX10008 router. The power rail distributes the output power produced by the power supplies to different router components. Each DC power supply provides power to all the components in the router.

NOTE: Route all the DC power supply cords away from the fan trays and power supply vents. Make sure that the power cords do not obstruct the fan trays or power cords.

A JNP10K-PWR-DC power supply can operate with only one input DC feed connected.

Each JNP10K-PWR-DC power supply has its own fan and is cooled by its own internal cooling system. The airflow is from the front of the power supply to the back. Hot air exhausts from the rear of the chassis.

SEE ALSO

[JNP10K-PWR-DC Power Specifications | 242](#)

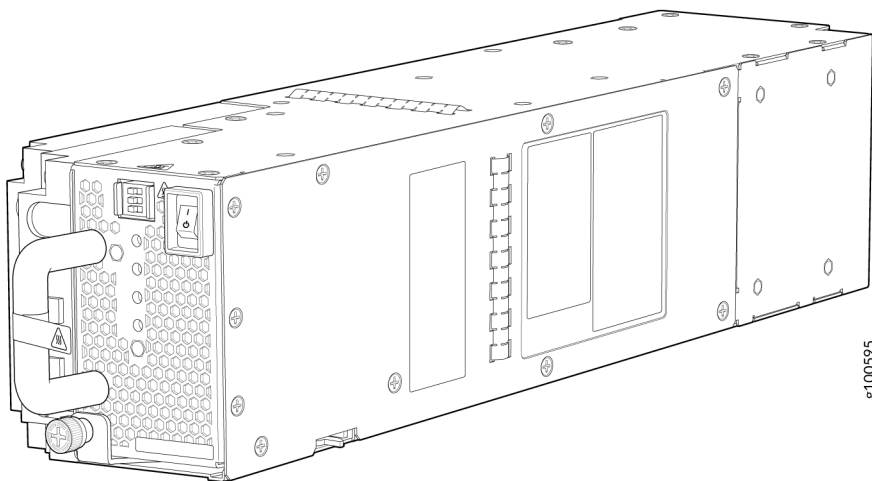
[Install a JNP10K-PWR-DC Power Supply | 391](#)

[Remove a JNP10K-PWR-DC Power Supply | 401](#)

JNP10K-PWR-DC2 Power Supply

The JNP10K-PWR-DC2 power supply provides two power supplies in a single housing that accepts either 60 A or 80 A using four redundant input power feeds. See [Figure 36 on page 88](#).

Figure 36: JNP10K-PWR-DC2 Power Supply



The two internal power supplies (PS 0 and PS 1) each have redundant input feeds: A0 and/or B0 provide power to PS 0 and A1 and/or B1 provide power to PS 1. The input feed A0 or B0 with the highest input voltage provides power to PS 0. Similarly, the input feed A1 or B1 with the highest input voltage provides power to PS 1. A0, B0, A1, and B1 share the power if the input voltage is the same. You configure the input using a set of three DIP switches on the power supply faceplate that sets the combined output power for both internal power supplies. The output depends on the settings of these DIP switches. See [Table 17 on page 89](#). The output of the PS 0 and PS 1 shares the output power.

Table 17: DIP Switch Settings for JNP10K-PWR-DC2 Power Supplies

INP0—PS 0 (DIP Switch 1)	INP1—PS 1 (DIP Switch 2)	H/L (High Input 80 A/ Low Input 60 A)	Output Power
On	On	On (80 A)	5500 W
On	On	Off (60 A)	4400 W
On	Off	On (80 A)	2750 W
Off	On	On (80 A)	2750 W
On	Off	Off (60 A)	2200 W
Off	On	Off (60 A)	2200 W

A combined output of 5500 W with PS 0 and PS 1 active is available at 56 VDC or greater. If the input voltage is less than 56 VDC, the output power decreases linearly, keeping the input current a little below the default 60 A. However, the power supply supports 5500 W at lower input voltage if you provide 80 A and sets the power supply switch to 80 A setting.

A combined output of 2750 W with only PS 0 or PS 1 active is available at 56 VDC or greater. If the input voltage is less than 56 VDC, the output power decreases linearly, keeping the input current a little below the default 60 A. However, the power supply supports 2750 W at lower input voltage if you provide 80 A and sets the power supply switch to 80 A setting.

The JNP10K-PWR-DC2 power supply requires a dedicated circuit breaker for each input DC feed. You must use a circuit breaker that is rated for 80 A DC with medium delay.

The power supplies have internal fans that contribute to chassis cooling. Therefore, all the power supplies must be present in a running chassis to have the adequate airflow. While all power supplies are

required to be present in the chassis, they do not necessarily be connected to power. If a power supply is installed in a slot but is not connected to a power source, it draws power from the chassis to power the internal fans in the power supplies.



WARNING: The router is pluggable type A equipment installed in a restricted-access location. It has a separate protective earthing terminal on the chassis that must be connected to earth ground permanently to ground the chassis adequately and protect the operator from electrical hazards.

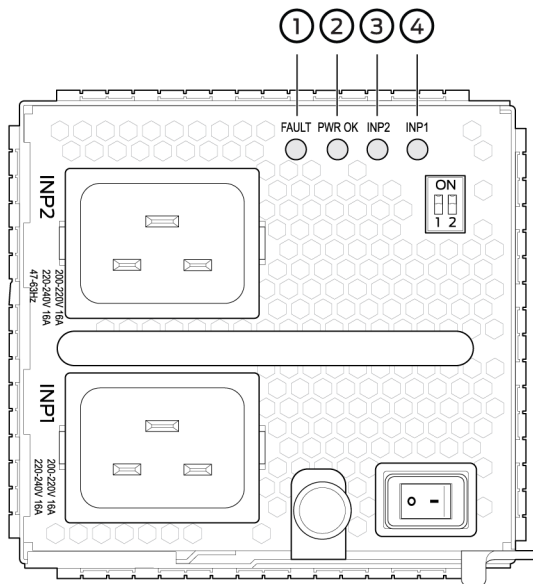


CAUTION: Before you begin installing the router, ensure that a licensed electrician has attached an appropriate grounding lug to the grounding cable that you supply. Using a grounding cable with an incorrectly attached lug can damage the router.

JNP10K-PWR-AC Power Supply LEDs

The JNP10K-PWR-AC power supply has four LEDs on its faceplate: **INP1**, **INP2**, **PWR OK**, and **FAULT**. These LEDs display information about the status of the power supply. See [Figure 37 on page 90](#).

Figure 37: LEDs on the JNP10K-PWR-AC Power Supply



1– **FAULT LED**

2– **PWR OK LED**

3– **INP2 LED**

4– **INP1 LED**

Table 18 on page 91 describes the LEDs on the JNP10K-PWR-AC power supply.

Table 18: LEDs on the JNP10K-PWR-AC Power Supply

LED	Color	State	Description
<ul style="list-style-type: none"> • INP1 <ul style="list-style-type: none"> • INP1 in the CLI output for Junos OS Evolved Release 20.4R2 or later. • INP0 in the CLI output for releases earlier than Junos OS Evolved Release 20.4R2. • INP2 <ul style="list-style-type: none"> • INP2 in the CLI output for Junos OS Evolved Release 20.4R2 or later • INP1 in the CLI output for releases earlier than Junos OS Evolved Release 20.4R2 	Green	Solid	The power supply is functioning properly.
	Yellow	Blinking	The power supply has detected a power input fault.
	None	Unlit	The power supply is switched off.
PWR OK	Green	Solid	The power supply is functioning properly.
	Yellow	Blinking	The power supply has detected a power output fault.
FAULT	None	Unlit	The power supply is functioning properly.

Table 18: LEDs on the JNP10K-PWR-AC Power Supply (*Continued*)

LED	Color	State	Description
	Red	Solid	The power supply has failed and must be replaced. Or, only one input is powered and the enabled router for the input that is not powered is set to ON . See " Install a JNP10K-PWR-AC Power Supply " on page 362 for more information about the enable switches.

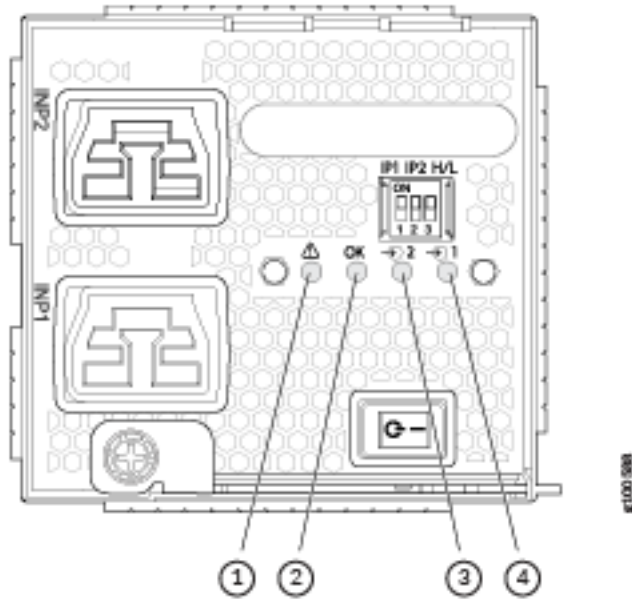
NOTE: If the **INP1** or **INP2** LED and the **PWR OK** LED are unlit, the AC power cable is not installed properly or the power supply has failed.

If the **INP1** or **INP2** LED is lit and the **PWR OK** LED is unlit, the AC power supply is not installed properly or the power supply has an internal failure.

JNP10K-PWR-AC2 Power Supply LEDs

The JNP10K-PWR-AC2 power supply has four LEDs on its faceplate: **!**, **OK**, **2**, and **1**. These LEDs display information about the status of the power supply. See [Figure 38 on page 93](#).

Figure 38: LEDs on a JNP10K-PWR-AC2 Power Supply



1- ! LED	3- 2 LED
2- OK LED	4- 1 LED

Table 19 on page 93 describes the LEDs on a JNP10K-PWR-AC2 power supply.

Table 19: LEDs on the JNP10K-PWR-AC2 Power Supply

LED	Color	State	Description
1	Yellow	Solid	One of the following: <ul style="list-style-type: none"> The power supply is switched off. There is no input voltage. The input voltage is present, but a fault is detected.
	Green	Solid	The power supply is functioning properly.

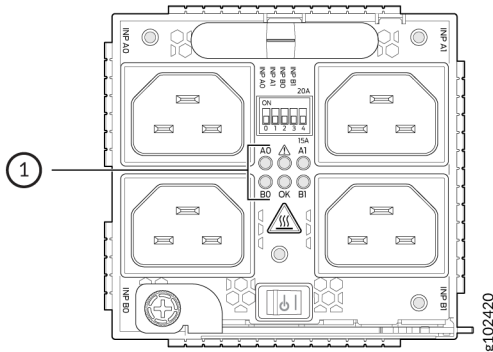
Table 19: LEDs on the JNP10K-PWR-AC2 Power Supply (*Continued*)

LED	Color	State	Description
2 <ul style="list-style-type: none"> INP2 in the CLI output for Junos OS Evolved Release 20.4R2 or later. INP1 in the CLI output for releases earlier than Junos OS Evolved Release 20.4R2. 	Yellow	Solid	One of the following: <ul style="list-style-type: none"> The power supply is switched off. There is no input voltage. The input voltage is present, but a fault is detected.
	Green	Solid	The power supply is functioning properly.
OK (Power OK)	Green	Solid	The power supply is functioning properly.
	Yellow	Blinking	The power supply output has detected a fault.
	Unlit	Off	The power supply is switched off.
! (Fault)	Red	Solid	The power supply has failed and must be replaced.
	Unlit	Off	The power supply is functioning normally.

JNP10K-PWR-AC3 Power Supply LEDs

The JNP10K-PWR-AC3 power supply has six LEDs on its faceplate: **!**, **OK**, **A0**, **A1**, **B0**, and **B1**. The numbered LEDs correspond to the four inputs (INP-A0, INP-A1, INP-B0, and INP-B1). Additionally, there are two more LEDs **OK** (Power OK) and **!**(Fault). These LEDs display information about the status of the power supply. See [Figure 39 on page 95](#).

Figure 39: LEDs on a JNP10K-PWR-AC3 Power Supply



1—LEDs on the JNP10K-PWR-AC3 Power Supply denoting:

NOTE: Physical markings on the power supply are **1, 2, 3, and 4**. These markings correspond to INP-A0, INP-A1, INP-B0, and INP-B1 in the show chassis power output (see [Table 20 on page 95](#)).

Table 20: Physical Markings on AC3 Chassis Versus show chassis power Command

Physical Marking on JNP10K-PWR-AC3	show chassis power Command
INP A0	INP-A0
INP A1	INP-A1
INP B0	INP-B0
INP B1	INP-B1

[Table 21 on page 96](#) describes the LEDs on a JNP10K-PWR-AC3 power supply, color on the LED, state, and its meaning.

Table 21: JNP10K-PWR-AC3 LEDs on a PTX10004

LED	Color	State	Description
1 or (A0 in CLI output)	Yellow	Solid	One of the following: <ul style="list-style-type: none"> • The power supply is switched off. • There is input voltage. • The input voltage is present, but a fault is detected.
	Green	Solid	The power supply is functioning properly.
2 or (A1 in CLI output)	Yellow	Solid	One of the following: <ul style="list-style-type: none"> • The power supply is switched off. • There is input voltage. • The input voltage is present, but a fault is detected.
	Green	Solid	The power supply is functioning properly.
3 or (B0 in CLI output)	Yellow	Solid	One of the following: <ul style="list-style-type: none"> • The power supply is switched off. • There is input voltage. • The input voltage is present, but a fault is detected.
	Green	Solid	The power supply is functioning properly.

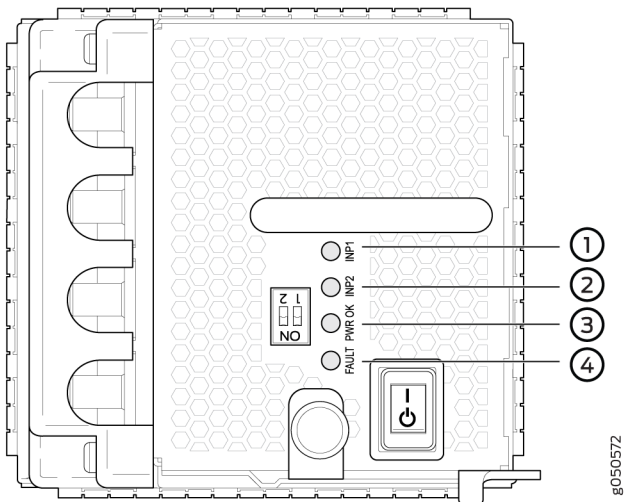
Table 21: JNP10K-PWR-AC3 LEDs on a PTX10004 (Continued)

LED	Color	State	Description
4 or (B1 in CLI output)	Yellow	Solid	One of the following: <ul style="list-style-type: none"> • The power supply is switched off. • There is input voltage. • The input voltage is present, but a fault is detected.
	Green	Solid	The power supply is functioning properly.
OK (Power OK)	Green	Solid	The power supply is functioning properly.
	Yellow	Blinking	The power supply output has detected a fault.
	Unlit	Off	The power supply is switched off.
! (Fault)	Red	Solid	The power supply has failed and must be replaced.
	Unlit	Off	The power supply is functioning normally.

JNP10K-PWR-DC Power Supply LEDs

The JNP10K-PWR-DC power supply has four LEDs on its faceplate: **INP1**, **INP2**, **PWR OK**, and **FAULT**. These LEDs display information about the status of the power supply. See [Figure 40 on page 98](#).

Figure 40: LEDs on a JNP10K-PWR-DC Power Supply



1- INP1 LED	3- PWR OK LED
2- INP2 LED	4- FAULT LED

NOTE: Physical markings on the power supply are **INP1** and **INP2**. These markings correspond to PS0, A0, or B0 and PS1, A1, or B1 in the show chassis power output (see [Table 22 on page 98](#)).

Table 22: Physical Markings on Chassis Versus show chassis power Command

Physical Marking on JNP10K-PWR-DC2	show chassis power Command
INP1	PS0 in the CLI output for releases earlier than Junos OS Release 20.4R2 and Junos OS Evolved Release 20.4R2 A0 or B0 in the CLI output for Junos OS Release 20.4R2 or later and Junos OS Evolved Release 20.4R2 or later
INP2	PS1 in the CLI output for releases earlier than Junos OS Release 20.4R2 and Junos OS Evolved Release 20.4R2 A1 or B1 in the CLI output for Junos OS Release 20.4R2 or later and Junos OS Evolved Release 20.4R2 or later

[Table 23 on page 99](#) describes the LEDs on the JNP10K-PWR-DC power supply.

Table 23: LEDs on a JNP10K-PWR-DC Power Supply

LED	Color	State	Description
<ul style="list-style-type: none"> • INP1 <ul style="list-style-type: none"> • INP1 in the CLI output for Junos OS Evolved Release 20.4R2 or later. • INP0 in the CLI output for releases earlier than Junos OS Evolved Release 20.4R2. • INP2 <ul style="list-style-type: none"> • INP2 in the CLI output for Junos OS Evolved Release 20.4R2 or later. • INP1 in the CLI output for releases earlier than Junos OS Evolved Release 20.4R2. 	Yellow	Blinking	Indicates that the DC power input voltage is not within normal operating range.
	Green	Solid	DC power is within operating range (-40 VDC to -72 VDC).
	Unlit	Off	The power supply is switched off.
PWR OK	Green	Solid	DC power output is within normal operating range.
	Yellow	Blinking	The output is out of the limits.
FAULT	Red	Solid	Power supply has failed and must be replaced.

Table 23: LEDs on a JNP10K-PWR-DC Power Supply (Continued)

LED	Color	State	Description
	Unlit	Off	Power supply is functioning normally. Or, only one input is powered and the enable switch for the input that is not powered is set to ON . See "Install a JNP10K-PWR-DC Power Supply" on page 391 for more information on the enable switches.

NOTE: If the **INP1** or **INP2** and the **PWR OK** LED are unlit, the power cables are not installed properly or the power supply has failed.

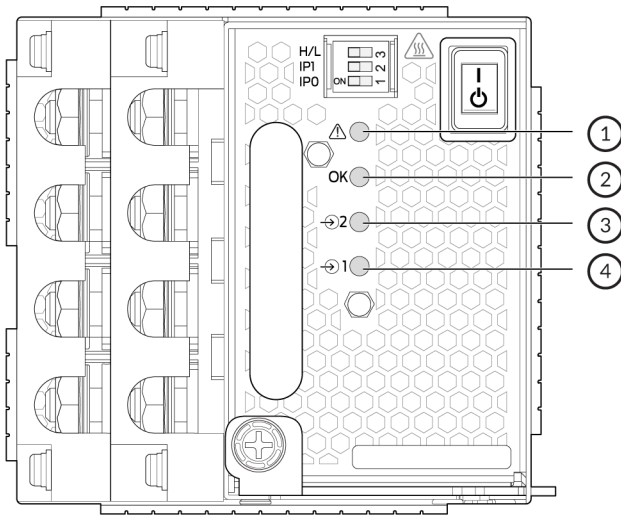
If the **INP1** or **INP2** LED is lit green and the **PWR OK** LED is unlit, the power supply is not installed properly or the power supply has an internal failure.

If the **FAULT** LED is blinking, add a power supply to balance the power demand and supply.

JNP10K-PWR-DC2 Power Supply LEDs

A JNP10K-PWR-DC2 power supply has four LEDs on its faceplate: **!**, **OK**, **2**, and **1**. These LEDs display information about the status of the power supply. See [Figure 41 on page 101](#).

Figure 41: LEDs on a JNP10K-PWR-DC2 Power Supply



1- ! LED	3- 2 LED
2- OK LED	4- 1 LED

You can find out the version of the firmware installed in the power supply from the output of `show system firmware` command. [Table 24 on page 101](#) describes the LEDs on a JNP10K-PWR-DC2 power supply if the firmware installed in the power supply is 300.300.208.208.304 or higher. [Table 25 on page 103](#) describes the LEDs on a JNP10K-PWR-DC2 power supply if the firmware installed in the power supply is lower than 300.300.208.208.304.

Table 24: LEDs on a JNP10K-PWR-DC2 Power Supply (with 300.300.208.208.304 or higher firmware installed in it)

Feed 0	Feed 1	State of the Power Supply Switch	LED 1	LED 2	OK LED	! LED
Off	Off	Off	Orange	Orange	Off	Red
A or B	Off	Off	Green—Blinking	Orange	Off	Red
A and B	Off	Off	Green	Orange	Off	Red

Table 24: LEDs on a JNP10K-PWR-DC2 Power Supply (with 300.300.208.208.304 or higher firmware installed in it) (Continued)

Feed 0	Feed 1	State of the Power Supply Switch	LED 1	LED 2	OK LED	! LED
Off	A or B	Off	Orange	Green—Blinking	Off	Red
A or B	A or B	Off	Green—Blinking	Green—Blinking	Off	Red—Blinking
A and B	A or B	Off	Green	Green—Blinking	Off	Red—Blinking
Off	A and B	Off	Orange	Green	Off	Red
A or B	A and B	Off	Green—Blinking	Green	Off	Red—Blinking
A and B	A and B	Off	Green	Green	Off	Off
Off	Off	On	Orange	Orange	Off	Red
A or B	Off	On	Green—Blinking	Orange	Green	Red
A and B	Off	On	Green	Orange	Green	Red
Off	A or B	On	Orange	Green—Blinking	Green	Red
A or B	A or B	On	Green—Blinking	Green—Blinking	Green	Red—Blinking
A and B	A or B	On	Green	Green—Blinking	Green	Red—Blinking

Table 24: LEDs on a JNP10K-PWR-DC2 Power Supply (with 300.300.208.208.304 or higher firmware installed in it) (Continued)

Feed 0	Feed 1	State of the Power Supply Switch	LED 1	LED 2	OK LED	! LED
Off	A and B	On	Orange	Green	Green	Red
A or B	A and B	On	Green—Blinking	Green	Green	Red—Blinking
A and B	A and B	On	Green	Green	Green	Off

Table 25: LEDs on a JNP10K-PWR-DC2 Power Supply (with firmware lower than 300.300.208.208.304 installed in it)

LED	Color	State	Description
<ul style="list-style-type: none"> • 1 • PS0 in the CLI output for releases earlier than Junos OS Release 20.4R2 and Junos OS Evolved Release 20.4R2 • A0 or B0 in the CLI output for Junos OS Release 20.4R2 or later and Junos OS Evolved Release 20.4R2 or later 	Green	Solid	The DC power is within operating range (-40 VDC to -72 VDC).
	Yellow	Blinking (if the part number of the power supply is 740-073256 Rev 3 or earlier)	The DC power input voltage is not within normal operating range.
	Orange	On steadily (if the part number of the power supply is 740-073256 Rev 4 or later)	
<ul style="list-style-type: none"> • 2 • PS1 in the CLI output for releases 			

Table 25: LEDs on a JNP10K-PWR-DC2 Power Supply (with firmware lower than 300.300.208.208.304 installed in it) (Continued)

LED	Color	State	Description
<p>earlier than Junos OS Release 20.4R2 and Junos OS Evolved Release 20.4R2</p> <ul style="list-style-type: none"> A1 or B1 in the CLI output for Junos OS Release 20.4R2 or later and Junos OS Evolved Release 20.4R2 or later 	Unlit	Off	The power supply is switched off.
OK (Power OK)	Green	Solid	The DC power output is within normal operating range.
	Yellow	Blinking	The power supply output is out of the power limits.
! (Fault)	Red	Solid	The power supply inputs are misconfigured or the power supply has failed and must be replaced.
	Red	Blinking	The power supply feed is missing one of the inputs (A or B).
	Unlit	Off	The power supply is functioning normally. Or, only one input is powered and the enable switch for the input that is not powered is set to ON . See "Connect DC Power to a PTX10008" on page 323 for more information about the enable switches.

NOTE: If the 1 or 2 and the OK LED are unlit, the power cables are not installed properly or the power supply has failed.

If the **1** or **2** LED is lit green and the **OK** LED is unlit, the power supply is not installed properly or the power supply has an internal failure.

If the **!** LED is blinking, add a power supply to balance the power demand and supply.

PTX10008 Routing and Control Board Components and Descriptions

IN THIS SECTION

- [PTX10008 Routing and Control Board Description | 105](#)
- [PTX10008 Routing and Control Board LEDs | 109](#)

The Routing and Control Board (RCB) is an integrated board and a single FRU that provides Routing Engine and Control Board (CB) functionality. The Routing Engine performs all route-processing functions, whereas the CB performs chassis control and management plane functionality. The RCB provides control plane functions. You can install one or two RCBs on the router. Each RCB functions as a unit.

PTX10008 Routing and Control Board Description

IN THIS SECTION

- [Routing and Control Board Functions | 107](#)
- [Routing and Control Board Components | 107](#)
- [Routing and Control Board Physical Specifications | 109](#)

The PTX10008 Routing and Control Board (RCB) is responsible for system management in a PTX10008 (see [Figure 42 on page 106](#)). The chassis can run with one or two RCBs. We ship the base configurations with one RCB; and you can expand the configuration with a second RCB for a fully-redundant system. When two RCBs are installed, one functions as the primary RCB and the second as a backup. If the primary RCB is removed, the backup RCB becomes the primary if GRES is configured.

PTX10008 routers support the following Routing Engines for systems running standard Junos OS:

- JNP10K-RE0
- JNP10K-RE1
- JNP10K-RE1-LT
- JNP10K-RE1-128G

PTX10008 routers that have JNP10008-SF3 installed support the following Routing Engines:

- JNP10K-RE1-E (64 GB, runs Junos OS Evolved Release 19.4R1-S1 and later, spare)
- JNP10K-RE1-ELT (64 GB, runs limited Junos OS Evolved Release 20.3R1 and later, spare)
- JNP10K-RE1-E128 (128 GB, runs Junos OS Evolved Release 19.4R1-S1 and later, spare)
- JNP10K-RE2-E128 (128 GB, runs Junos OS Evolved Release 22.4R1 and later, spare)

Figure 42: JNP10K-RE0

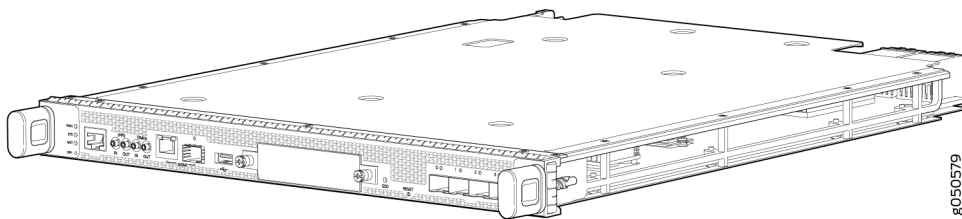
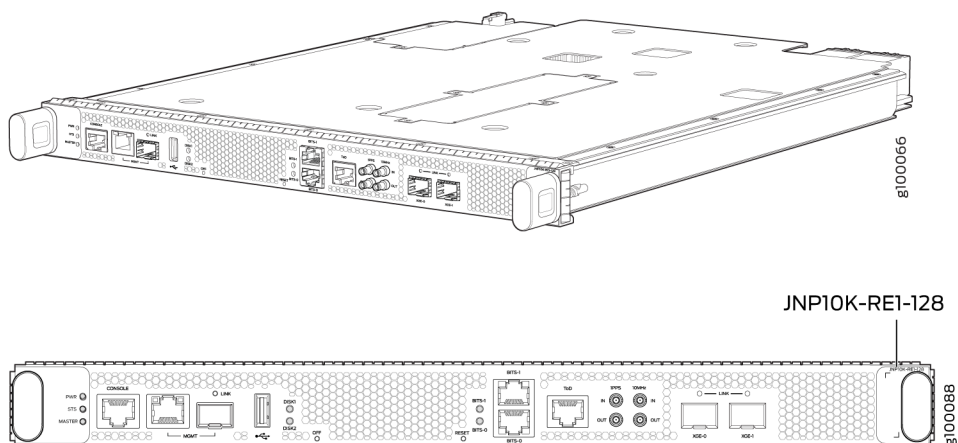


Figure 43: JNP10K-RE1, JNP10K-RE1-E, JNP10K-RE1-128G, JNP10K-RE1-ELT, JNP10K-RE1-E128, and JNP10K-RE2-E128



Routing and Control Board Functions

The Routing and Control Board integrates the control plane and Routing Engine functions into a single management unit. Each RCB provides all the functions needed to manage the operation of the modular chassis:

- System control functions such as environmental monitoring
- Routing Layer 2 and Layer 3 protocols
- Communication to all components such as line cards, Switch Interface Boards (SIBs), and power and cooling
- Transparent clocking
- Alarm and logging functions

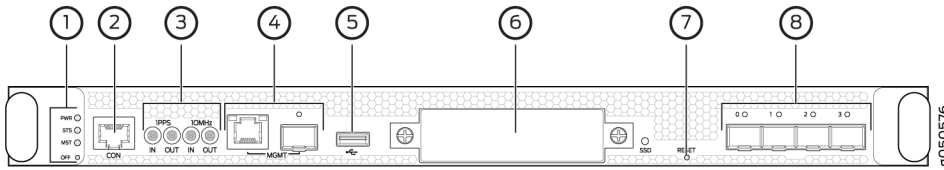
Routing and Control Board Components

Each RCB consists of the following internal components:

- Quad-core 2.5-GHz CPU
- 32 GB SDRAM
- SATA SSD

Other standard features are shown in [Figure 44 on page 108](#).

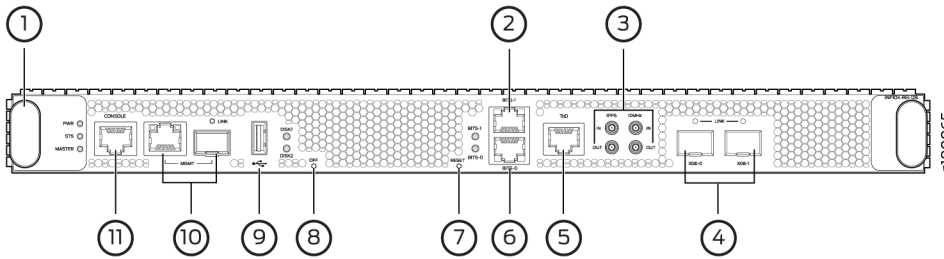
Figure 44: Routing and Control Board Faceplate (JNP10K-RE0)



1– RCB status LEDs	5– USB 2.0 port
2– Console (CON) port	6– Secondary 50-GB SATA SSD slot
3– PTP-capable connections: SMB In, SMB Out, 10 MHz In, 10 MHz Out	7– Reset (RESET) button
4– Ethernet management (MGMT) ports: RJ-45 port for 10/100/1000 BASE-T (em0) and small-form factor pluggable (SFP) for port fiber (em1). If both copper and fiber cables are installed, the RJ-45 is the default.	8– Four SFP+ ports (reserved for future use)

NOTE: You can use either management interface, em0 or em1 when the RCB is running as the primary RE. Use only em1 when the RCB is running as the backup RE.

Figure 45: Routing and Control Board Faceplate (JNP10K-RE1 and JNP10K-RE1-E, JNP10K-RE1-LT and JNP10K-RE1-ELT)



1– Handles	7– Reset button
2– BITS-1 clock port	8– Online/Offline button
3– GPS clock ports (1PPS and 10MHz)	9– USB port
4– XGE-0 and XGE-1 not used (reserved ports)	10– Management (MGMT) ports
5– ToD —Time-of-day (TOD) port	11– Console (CONSOLE) port
6– BITS-0 clock port	

Routing and Control Board Physical Specifications

All the RCBs have the same physical specifications. [Table 26 on page 109](#) shows the physical specifications of the RCBs.

Table 26: RCB Physical Specifications

Height	Width	Depth	Weight
1.3 in. (3.3 cm)	15.05 in. (38.2 cm)	18.96 in. (48.2 cm)	12.2 lb (5.54 kg)

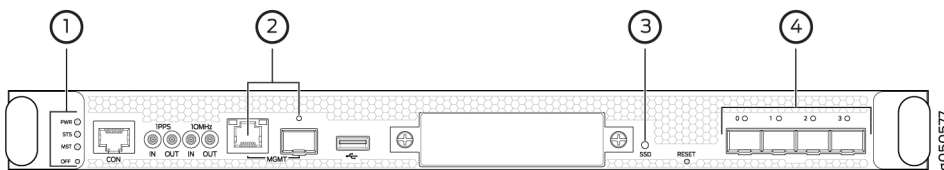
PTX10008 Routing and Control Board LEDs

IN THIS SECTION

- [Routing and Control Board Status Panel LEDs | 110](#)
- [PTX10008 Management Port LEDs | 111](#)
- [SATA SSD LEDs | 113](#)
- [Clock LEDs \(JNP10K-RE1, JNP10K-RE1-LT, and JNP10K-RE1-128\) | 113](#)

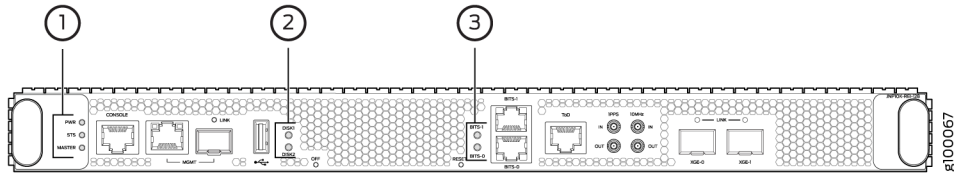
The PTX10008 Routing and Control Boards (RCBs) have various types of LED indicators (see [Figure 46 on page 109](#)).

Figure 46: PTX10008 Routing and Control Board (JNP10K-RE0) LEDs



1– RCB status panel LEDs	3– SATA SSD
2– Management ports and LED	4– Virtual port connection

Figure 47: PTX10008 Routing and Control Board (JNP10K-RE1 and JNP10K-RE1-E) LEDs

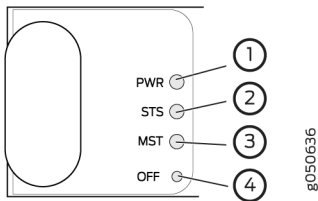


1– RCB status panel LEDs	3– Clock LEDs— BITS-0 and BITS-1
2– SSD LEDs— DISK1 and DISK2	

Routing and Control Board Status Panel LEDs

The RCB status panel LEDs indicate the state of the RCB (see [Figure 48 on page 110](#)).

Figure 48: Routing and Control Board Status Panel LEDs and Button



1– Power (PWR) LED	3– Primary (MST) LED
2– Status (STS) LED	4– Offline (OFF) button

[Table 27 on page 110](#) describes the LEDs on the RCB status panel.

Table 27: Routing and Control Board Status LEDs

LED	Color	State	Description
PWR (Power)	Green	On steadily	The RCB is receiving adequate power.
	Yellow	Blinking	The RCB has detected an error.
	None	Unlit	The RCB is not powered up.

Table 27: Routing and Control Board Status LEDs (Continued)

LED	Color	State	Description
STS (Status)	Green	On steadily	The RCB is online and functioning correctly.
	Green	Blinking	The beacon feature is enabled.
	Yellow	Blinking	The RCB has detected an error.
	None	Unlit	The RCB is not receiving power.
MST (Primary)	Green	On steadily	The RCB is the primary RCB.
	None	Unlit	The RCB is the backup RCB.

PTX10008 Management Port LEDs

The two management ports on the RCB of a PTX10008 router have LEDs that indicate link status and link activity. These two ports, located on the RCB panel between the clocking connections and the USB port, are both labeled **MGMT**. The left management port (RJ-45) is for 10/100/1000 BASE-T connections, and the right port (SFP) is for 10/100/1000 BASE-T and small form-factor pluggable (SFP) 1000 BASE-X connections (see [Figure 49 on page 111](#)). The copper (RJ-45) port has separate LEDs for status and activity. The fiber (SFP) port has a combination link and activity LED.

Figure 49: Management Port LEDs on a PTX10008

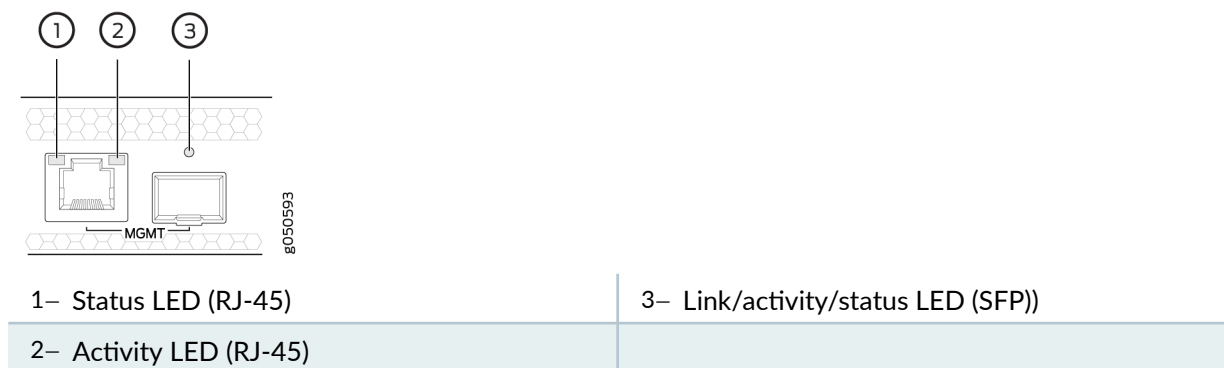


Table 28 on page 112 describes the RJ-45 management port LEDs, and Table 29 on page 112 describes the SFP status LEDs.

Table 28: RJ-45 Management Port LEDs on a PTX10008 Routing and Control Board

LED	Color	State	Description
Port speed	Unlit	Off	The port speed is 10 MB.
	Green	Blinking	The port speed is 100 MB.
	Green	On steadily	The port speed is 1000 MB.
Link/Activity/Status	Unlit	Off	No link is established, there is a fault, or the link is down.
	Green	On steadily	A link is established.
		Blinking	There is link activity.
	Yellow	Blinking or flickering	The beacon feature is enabled.

Table 29: SFP Management Port LEDs on a PTX10008 Routing and Control Board

LED	Color	State	Description
Link/Activity/Status	Unlit	Off	No transceiver is present.
	Green	On steadily	A link is established. The interface is up.
	Green	Blinking or flickering	The beacon feature is enabled.
	Yellow	Blinking	An error has occurred.

XGE0 and **XGE1** are not used.

SATA SSD LEDs

The Serial Advanced Technology Attachment (SATA) solid-state drive (SSD) LEDs indicate the status of the secondary drive.

[Table 30 on page 113](#) describes the LEDs for the secondary SATA drive.

Table 30: Routing and Control Board SSD Status LEDs

LED	Color	State	Description
SSD on JNP10K-RE0	Green	On steadily	A SATA drive is present.
DISK1 and DISK2 on JNP10K-RE1	Green	Blinking	The drive is active.
	Yellow	On steadily	The drive is active.
	Dark	Unlit	A drive is not installed.

Clock LEDs (JNP10K-RE1, JNP10K-RE1-LT, and JNP10K-RE1-128)

The clock LEDs indicate whether clocking is active.

[Table 31 on page 113](#) describes the BITS LEDs starting in Junos Evolved 21.4 R1.

[Table 32 on page 114](#) describes the clock LEDs in releases earlier than Junos Evolved 21.4 R1.

Table 31: Description of BITS LEDs

LEDs	Color/State	Description
Clock LEDs—BITS-0 and BITS-1	Green	The clock synchronization source is configured and qualified, the clock synchronization output is configured, and the output is active.
		The clock synchronization source is not configured but the clock synchronization output is configured and active.

Table 31: Description of BITS LEDs (Continued)

LEDs	Color/State	Description
		The clock synchronization source is configured and qualified but the clock synchronization output is not configured.
	Red	The clock synchronization source is configured and qualified, and the output is active and is in holdover state.
		The clock synchronization source is not configured, but the output is active and is in holdover state.
		The clock synchronization source is configured, but has failed.
		The TX status is in squelched mode.
	Off	Both the clock synchronization source and the clock synchronization output are not configured.

Table 32: Routing and Control Board Clock Status LED

LEDs	Color	State	Description
Clock LEDs—BITS-0 and BITS-1	Red	Off	Clock is active.
		On steadily	Clock is not working.

SEE ALSO

[Install a PTX10008 Routing and Control Board | 343](#)

[Remove a PTX10008 Routing and Control Board | 345](#)

PTX10008 Switch Fabric

IN THIS SECTION

- [PTX10008 Switch Interface Board Description | 115](#)
- [PTX10008 Switch Interface Board LEDs | 119](#)

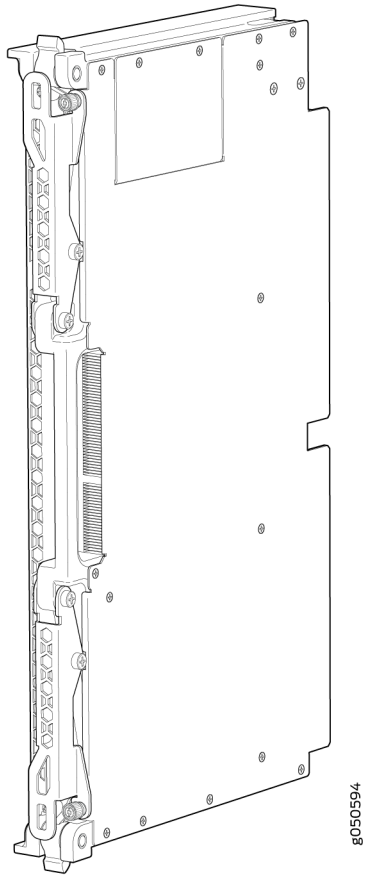
The PTX10008 Switch Interface Boards (SIBs) form the switch fabric for the router.

PTX10008 Switch Interface Board Description

Switch Interface Boards (SIBs) create the switch fabric for the PTX10008. Each PTX10008 contains between five and six SIBs that are installed vertically, mid-chassis, between the line cards and the RCBs in the front and the fan trays in the rear.

The SIBs make up the PTX10008 switching plane. There are two models of SIBs: the JNP10008-SF (see [Figure 50 on page 116](#)) and the JNP10008-SF3 (see [Figure 51 on page 117](#)). SIBs must all be of the same model type in a running chassis. On both models, the SIB has eight connectors that match and connect to a connector on one of the eight line cards. The JNP10008-SF SIB supports five standard line cards and operates in standard Junos OS. The JNP10008-SF3 SIB supports the 14.4 Tbps line card and operates in Junos OS Evolved systems. See [Table 33 on page 117](#) for a comparison of the two models.

Figure 50: JNP10008-SF for Standard Line Cards



8050594

Figure 51: JNP10008-SF3 for 14.4-Terabyte Line Cards

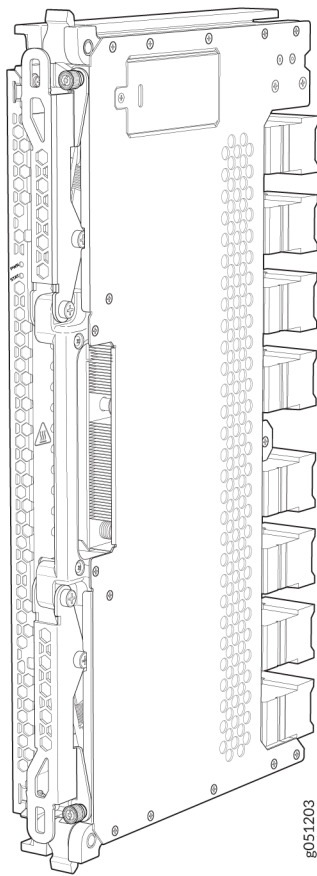


Table 33: SIB Specifications

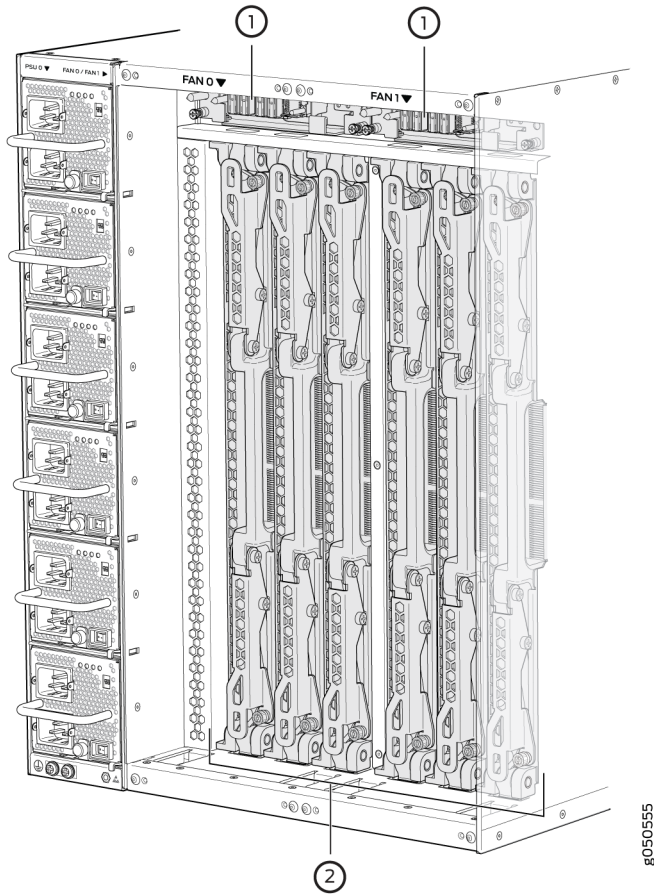
Specification	JNP10008-SF	JNP10008-SF3
Operating system	Junos OS Release 17.2R1 and later	Junos OS Evolved Release 19.4R1S1 and later
Supported line cards	<ol style="list-style-type: none"> 1. PTX10K-LC1101 2. PTX10K-LC1102 3. PTX10K-LC1104 4. PTX10K-LC1105 5. QFX10000-60S-6Q 	PTX10K-LC1201-36CD PTX10K-LC1202-36MR

Table 33: SIB Specifications (Continued)

Specification	JNP10008-SF	JNP10008-SF3
Number of SIBs required for operation	Base systems require five SIBs; redundant systems require six SIBs	Base systems require three SIBs; partial bandwidth PREM2 systems require four SIBs; and full bandwidth redundant systems require six SIBs
Height	19.7 in. (50.04 cm)	19.7 in. (50.04 cm)
Width	1.8 in. (4.57 cm)	1.8 in. (4.57 cm)
Depth	10.4 in. (26.42 cm)	10.29 in. (26.14 cm)
Weight	14.8 lb (6.71 kg)	15.2 lb (6.89 kg)

SIBs are hot-removable and hot-insertable field-replaceable units (FRUs). They are not visible from the outside of the router chassis. If you don't know which switch fabric you have installed, you can use the CLI command `show chassis hardware models`. Otherwise, you must remove one of the fan trays in order to view the SIBs. For instructions on removing the fan trays, see ["Remove a PTX10008 Fan Tray" on page 351](#). The SIBs are numbered **SIB0** to **SIB5** from left to right. See [Figure 52 on page 119](#).

Figure 52: SIBs Installed in a PTX10008



1– Fan tray controllers

2– SIBs

SEE ALSO

[Install a PTX10008 Switch Interface Board | 424](#)

[Remove a PTX10008 Switch Interface Board | 429](#)

PTX10008 Switch Interface Board LEDs

The Switch Interface Board (SIB) has two status LEDs at the top of each board. See [Figure 53 on page 120](#).

Figure 53: SIB LEDs

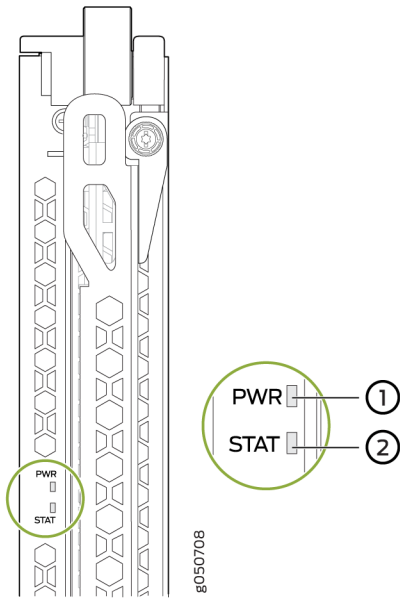


Table 34 on page 120 describes the functions of these LEDs.

Table 34: SIB LEDs

Label	Color	State	Description
PWR (Power)	Green	On steadily	The SIB is receiving power.
	Yellow	Blinking	Power fault.
	Unlit	Off	The SIB is either offline or not receiving power.
STAT (Status)	Green	On steadily	The SIB is online and functioning normally.
	Green	Blinking	The beacon feature is enabled.
	Yellow	On steadily	The SIB has failed.
	Unlit	Off	The SIB is offline.

SEE ALSO

| [How to Handle and Store PTX10008 Line Cards, RCBs, and SIBs](#) | 420

PTX10008 Line Card Components and Descriptions

IN THIS SECTION

- [PTX10K-LC1101 Line Card](#) | 123
- [PTX10K-LC1102 Line Card](#) | 126
- [PTX10K-LC1104 Line Card](#) | 134
- [1.2-Terabyte Per Second DWDM OTN Module Wavelengths](#) | 144
- [PTX10K-LC1105 Line Card](#) | 170
- [PTX10K-LC1201-36CD Line Card](#) | 175
- [PTX10K-LC1202-36MR Line Card](#) | 181
- [QFX10000-60S-6Q Line Card](#) | 187
- [PTX10008 Line Card LEDs](#) | 193

The line cards in PTX10008 routers combine a Packet Forwarding Engine and Ethernet interfaces in a single assembly. Line cards are field-replaceable units (FRUs) that can be installed in the line card slots on the front of the router chassis. The PTX10008 chassis supports up to eight line cards. Line cards are associated to the switch fabric for their system. See [Table 35 on page 122](#) for line cards that operate with the JNP10008-SF switch fabric and [Table 36 on page 123](#) for information about the 14.4 Tbps line card that operates with the JNP10008-SF3 switch fabric. The JNP10008-SF line cards are hot-insertable and hot-removable—you can remove and replace them without powering off the router or disrupting router functions.

Table 35: Compatible Line Cards for the JNP10008-SF Switch Fabric

Line Card	Description	Dimensions	Net Shipping Weight
PTX10K-LC1101	30-port 100-Gigabit or 40-Gigabit Ethernet	17.2 in. x 1.89 in x 20.5 in 43.68 cm x 4.8 cm x 52.07 cm	27 lbs 12.2 kg
PTX10K-LC1102	36-port 40-Gigabit Ethernet; 12 ports support either 100-Gigabit or 40-Gigabit Ethernet	17.2 in. x 1.89 in x 20.5 in 43.68 cm x 4.8 cm x 52.07 cm	22.6 lbs 10.25 kg
PTX10K-LC1104	6-port DWDM with MACsec with flexible modulation at 100-Gbps, 150-Gbps, and 200-Gbps	17.2 in. x 1.89 in x 20.5 in 43.68 cm x 4.8 cm x 52.07 cm	32 lbs 14.5 kg
PTX10K-LC1105	30-port 100-Gigabit or 40-Gigabit Ethernet with MACsec	17.2 in. x 1.89 in x 20.5 in 43.68 cm x 4.8 cm x 52.07 cm	28.5 lbs 12.93 kg
QFX10000-60S-6Q	60-port 10-Gigabit or 1-Gigabit Ethernet; 2-port of 40-Gigabit or 100-Gigabit Ethernet; 4 port of 40-Gigabit	17.2 in. x 1.89 in x 20.5 in 43.68 cm x 4.8 cm x 52.07 cm	9.7 lb 4.39 kg

Table 36: Compatible Line Card for JNP10008-SF3 Switch Fabric Systems

Line Card	Description	Dimensions	Net Shipping Weight
PTX10K-LC1201-36CD	14.4 Tbps—36-port 400-Gigabit, 200-Gigabit, 100-Gigabit, 50-Gigabit, 25-Gigabit, or 10-Gigabit Ethernet This line card is only compatible with the JNP10008-SF3 switch fabric.	17.2 in. x 1.89 in. x 21.3 in. (43.68 cm x 4.8 cm x 54.1 cm)	35 lb (15.88 kg)
PTX10K-LC1202-36MR	4.8 Tbps—32 ports capable of supporting 100-Gbps, 4 ports capable of supporting 400-Gbps speed. This line card is compatible only with the JNP10008-SF3 switch fabric.	17.2 in. x 1.9 in. x 21.3 in. (43.68 cm x 4.8 cm x 54.1 cm)	21 lb (9.5 kg)

PTX10K-LC1101 Line Card

IN THIS SECTION

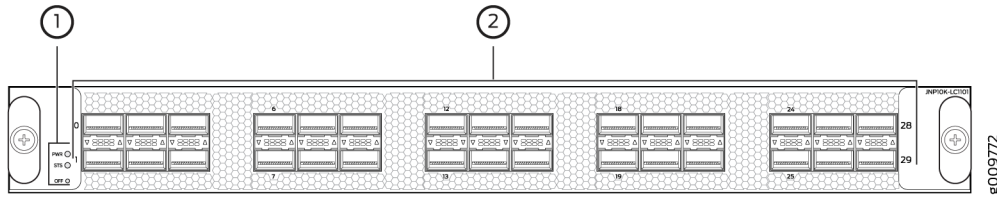
- [Overview | 123](#)
- [Channelizing 40GbE Ports | 124](#)
- [Network Ports | 126](#)

Overview

The PTX10K-LC1101 line card consists of 30 quad small form-factor pluggable (QSFP28) cages that support either 40GbE or 100GbE Ethernet optical transceivers; see [Figure 54 on page 124](#). The line cards also support 10GbE interfaces. For 10GbE, you must configure the port using the channelization-speed command. By default, the interfaces are created with 100-Gbps port speed. If the user plugs in a 40GbE or 4x10GbE transceiver, you must configure the appropriate port speed manually using the CLI.

Juniper Networks® PTX10008 Packet Transport Router and the PTX10016 that run Junos OS Release 17.2R1 and later support the PTX10K-LC1101 line card.

Figure 54: PTX10K-LC1101 Port Panel



1– Power LED (PWR), status :LED (STS), and offline/online button (OFF)

2– Network ports

Each network port can operate as a:

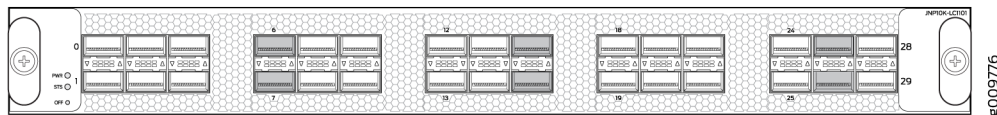
- 100GbE port when you use QSFP28 optical transceivers.
- 40GbE port when you use QSFP+ optical transceivers.

To change from the default mode (100GbE) to 40GbE channelized mode, use the Junos OS operational command `set chassis fpc slot slot-number pic 0 port port number channelization-speed 10g`.

Channelizing 40GbE Ports

You can configure each of the 40GbE ports on the PTX10K-LC1101 line card into four 10GbE channels. When ports are in channelization mode, the fourth port on each Packet Forwarding Engine is disabled, and the remaining four ports that are mapped to the same Packet Forwarding Engine can be used as either 4x10GbE, 40GbE, or 100GbE ports. The channelization mode works independently for each of the Packet Forwarding Engines on the PTX10K-LC1101 line card. See [Figure 55 on page 124](#) to see which ports are disabled and see [Table 37 on page 125](#) for the maximum port configurations.

Figure 55: Disabled Ports in Channelization Mode



Shaded ports are disabled when channelized.

Table 37: Maximum Port Configuration

Port Speed	Nonchannelized Mode (Mode D)	Channelized Mode (Mode A)
100 Gbps	30 or	24 or
40 Gbps	30	24 or
10 Gbps	0	96

Unlike the PTX10K-LC1102 line card, the PTX10K-LC1101 line card does not have port groups; instead, port behavior is tied to the ASIC associated with the port. To channelize a 40GbE port to 4 independent 10GbE ports, you must configure each port individually. For example, ASIC PE0 maps to ports 0, 2, 4, 6, and 8. The fourth port, port 6, is disabled. See [Table 38 on page 125](#) for the list of available ports and the associated ASIC mapping in [Figure 55 on page 124](#) to locate the available and disabled ports.

NOTE: If you change the channelization mode (mode D to mode A or mode A to mode D), the new port speed configuration does not cause an FPC to reboot automatically. Instead, it triggers an FPC `need bounce` alarm. To ensure that the new port speed configuration takes effect, you must manually reboot the FPC. The alarm is cleared when you manually reboot the FPC or delete the new port speed configuration.

NOTE: When you manually change the port speed from one setting to another, or when the you deactivate the interface, the `show interface interface-name` command shows the error `Device interface-name not found` for a brief interval. Ensure that the transceiver is in a working condition. The interface comes up subsequently.

Table 38: Port Mapping for Channelization

ASIC	Available Ports	Disabled Port
PE0	0, 2, 4, 8	6
PE1	1, 3, 5, 9	7

Table 38: Port Mapping for Channelization (Continued)

ASIC	Available Ports	Disabled Port
PE2	10, 12, 14, 18	16
PE3	11, 13, 15, 19	17
PE4	20, 22, 24, 28	26
PE5	21, 23, 25, 29	27

Network Ports

Each of the 30 QSFP28 ports supports:

- 100GbE using QSFP28 optical transceivers.
- 40GbE using QSFP+ optical transceivers.
- 40GbE to 10GbE or 1GbE QSFP-to-SFP adapter (QSA) (Junos OS Release 18.4R1 and later).

PTX10K-LC1102 Line Card

IN THIS SECTION

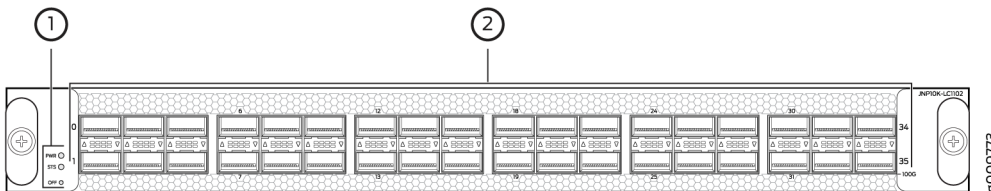
- [Overview | 127](#)
- [Network Ports | 127](#)
- [Channelization | 128](#)
- [Port Status and Activity LEDs | 132](#)

Overview

The PTX10K-LC1102 line card consists of 36 quad small form-factor pluggable plus (QSFP+) ports that support 40GbE optical transceivers. Out of these 36 ports, 12 ports also support 100GbE QSFP28 transceivers. The PTX10K-LC1102 line cards also support 10GbE interfaces. You can channelize 40GbE ports to four independent 10GbE interfaces by configuring the port speed and cabling the port using fiber breakout cables. See [Figure 56 on page 127](#).

PTX10008 and PTX10016 routers that run Junos OS Release 17.2R1 and later support the PTX10K-LC1102 line card.

Figure 56: PTX10K-LC1102 Port Panel



1– Power LED (**PWR**), status LED (**STS**), and offline/online button (**OFF**)

2– Network ports

You can configure each QSFP28 port as a:

- 100GbE port using QSFP28 optical transceivers. Only the ports with a fine black line underneath the port support 100GbE. When a QSFP28 transceiver is inserted into such a port and you configure the port for 100GbE, the two adjacent ports are disabled and the QSFP28 port is enabled for 100GbE.
- 40GbE port using QSFP+ optical transceivers.
- 10GbE port using breakout cabling and attached optical transceivers. When configured for channelization, the system converts the 40GbE port into four independent 10GbE channels.

Network Ports

Each of the 12 QSFP28 ports supports:

- 100GbE QSFP28 transceivers
- 40GbE QSFP+ transceivers
- 40GbE to 10GbE or 1GbE QSA (Junos OS Release 18.4R1 and later)

Each of the 36 QSFP+ ports supports:

- 40GbE QSFP+ transceivers
- 40GbE to 10GbE or 1GbE QSA (Junos OS Release 18.4R1 and later)

Channelization

Every second and sixth port in a 6xQSFP cage on a PTX10K-LC1102 line card supports 100GbE using QSFP28 transceivers. These 100GbE ports operate either as 100GbE ports or as 40GbE, but are recognized as channelized 4x10GbE by default. See [Figure 57 on page 128](#) for a closeup view of a 6xQSFP+ cage. When you insert a 40GbE transceiver into a 100GbE port, the port recognizes the 40 Gbps port speed. When you insert a 100GbE transceiver into the port and enable it in the CLI, the port recognizes the 100-Gbps speed and disables two adjacent 40GbE ports. See [Figure 58 on page 128](#) and [Figure 59 on page 129](#). You can also use a 100GbE transceiver and run it at 40GbE by using the CLI to set the port speed to 40GbE.

[Figure 57 on page 128](#) shows the default configuration of a cage of ports on the PTX10K-LC1102.

Figure 57: All Ports Are Enabled for Channelized 4x10GbE by Default

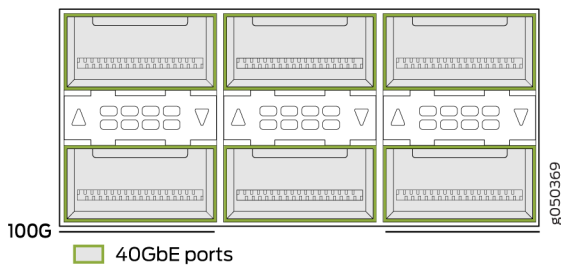


Figure 58: 100GbE Ports Can Operate at Either 100 Gbps or 4x10 Gbps Speed

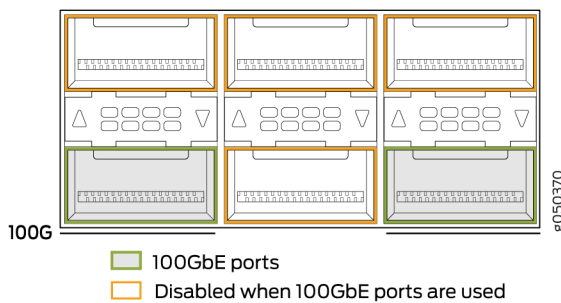
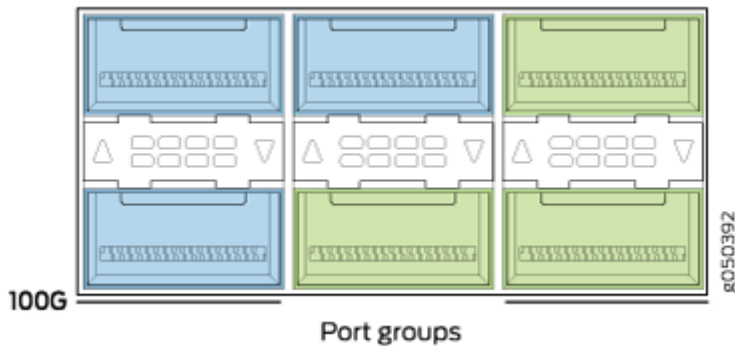
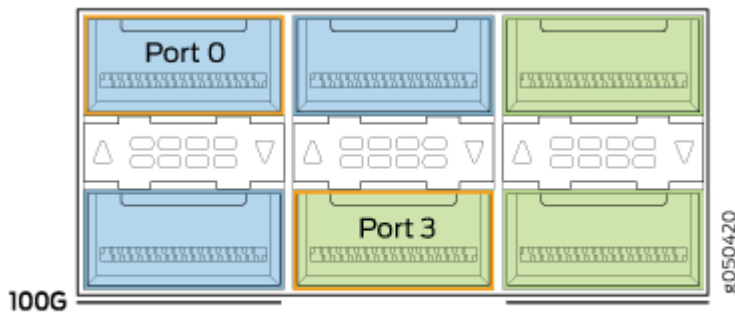


Figure 59: Enabled 100GbE Port Creates a Port Group and Disables the Associated 40GbE Port



The 40GbE ports can operate independently, be channelized into four 10GbE ports, or bundled with the next two consecutive ports and channelized into twelve 10GbE ports as a port range. Only the first and fourth port in each 6xQSFP cage are available to channelize a port range (see [Figure 60 on page 129](#)). You must configure the port speed using the `set chassis fpc slot slot-number pic slot-number port port-number speed speed` command. For example, to set the first router port as 40GbE (not channelized), use the `set chassis fpc slot 0 pic 0 port 0 speed 40g` command.

Figure 60: Use the First and Fourth Ports in Each 6xQSFP Cage to Channelize a Port Range



Use every third port to create a port range for 40-Gigabit Channelization.

[Table 39 on page 130](#) shows the available combinations for the ports. On the PTX10K-LC1102, the ports are enabled by default.

Table 39: PTX10K-LC1102 Port Mapping

Port Number	4x10GbE	4x10GbE Channelized Port Group	40GbE	100GbE	100GbE Disables
0	✓	✓	✓	-	-
1	✓		✓	✓	0, 2
2	✓		✓	-	-
3	✓	✓	✓	-	-
4	✓		✓	-	-
5	✓		✓	✓	3, 4
6	✓	✓	✓	-	-
7	✓		✓	✓	6, 8
8	✓		✓	-	-
9	✓	✓	✓	-	-
10	✓		✓	-	-
11	✓		✓	✓	9, 10
12	✓	✓	✓	-	-
13	✓		✓	✓	12, 14
14	✓		✓	-	-

Table 39: PTX10K-LC1102 Port Mapping (Continued)

Port Number	4x10GbE	4x10GbE Channelized Port Group	40GbE	100GbE	100GbE Disables
15	✓	✓	✓	-	-
16	✓		✓	-	-
17	✓		✓	✓	15, 16
18	✓	✓	✓	-	-
19	✓		✓	✓	18, 20
20	✓		✓	-	-
21	✓	✓	✓	-	-
22	✓		✓	-	-
23	✓		✓	✓	21, 22
24	✓	✓	✓	-	-
25	✓		✓	✓	24, 26
26	✓		✓	-	-
27	✓	✓	✓	-	-
28	✓		✓	-	-
29	✓		✓	✓	27, 28

Table 39: PTX10K-LC1102 Port Mapping (Continued)

Port Number	4x10GbE	4x10GbE Channelized Port Group	40GbE	100GbE	100GbE Disables
30	✓	✓	✓	-	-
31	✓		✓	✓	30, 32
32	✓		✓	-	-
33	✓	✓	✓	-	-
34	✓		✓	-	-
35	✓		✓	✓	33, 34

Port Status and Activity LEDs

Each network port has a bicolored up or down LED indicator that shows port status and link activity based on whether or not the port is configured for channelization. See [Figure 61 on page 132](#), [Table 40 on page 133](#), and [Table 41 on page 133](#).

Figure 61: Link and Activity Indicators for Network Ports on PTX10K-LC1102 Line Cards

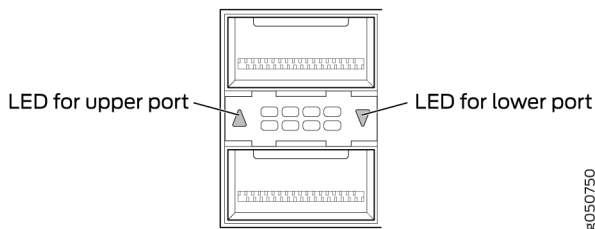


Table 40: Unchannelized Network Port Link and Activity LEDs on a PTX10K-LC1102 Line Card

Color	State	Description
Unlit	Off	The port is administratively disabled, there is no power, the link is down, or a transceiver is not present.
Green	On steadily	A link is established but there is no activity.
	Blinking	A link is up and there is activity.
Yellow or Amber	Slow blink or blip	The beacon function was enabled on the port.
	Blinking	A single LED blinking indicates an interface fault.

Table 41: Channelized Network Port Link and Activity LEDs on a PTX10K-LC1102 Line Card

Color	State	Description
Unlit	Off	The port is administratively disabled, there is no power, the link is down, or a transceiver is not present. All sub-channels are disabled.
Green	On steadily	A link is established. When channelized, all sub-channels are up. When not channelized, it indicates no activity.
	Blinking	A link is up and there is activity. When not channelized, it indicates the port is up and active in either 40GbE or 100GbE mode. When channelized, all four channels are up and active.
Yellow or Amber (channelized)	On steadily	At least one channel link is up, but not all channels are up. There is no activity on the channel link.
	Flashing	At least one channel link is up, but not all channels are up. There is activity on the channel link.
	Slow blink, or blip	The beacon function is enabled on one or more sub-channels.

Table 41: Channelized Network Port Link and Activity LEDs on a PTX10K-LC1102 Line Card
(Continued)

Color	State	Description
	Blinking	One or more sub-channels has a fault condition.
Yellow or Amber	Blinking	A single LED blinking indicates an interface fault. All four LEDs blink to indicate the beacon function was enabled on the port.

PTX10K-LC1104 Line Card

IN THIS SECTION

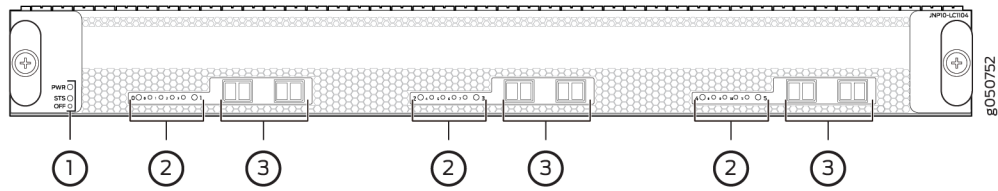
- [Hardware Features | 134](#)
- [Compatibility | 137](#)
- [Optical Transmit Specifications | 137](#)
- [Optical Receive Specifications | 139](#)
- [Status and Activity LEDs | 139](#)
- [Optical and Ethernet Interface Alarms and Defects | 141](#)

Hardware Features

The PTX10K-LC1104 line card provides up to 1.2 Tbps of packet forwarding for cloud providers, service providers, and enterprises that need coherent dense wavelength-division multiplexing (DWDM) with Media Access Control Security (MACsec) features. The 6-port line card, with built-in optics, supports flexible rate modulation at 100-Gbps, 150-Gbps, and 200-Gbps speeds. The PTX10008 and PTX10016 routers support a maximum of four PTX10K-LC1104 coherent line cards. See [Figure 62 on page 135](#).

PTX10008 routers that run Junos OS Release 17.4R1-S1 and later support the PTX10K-LC1104 line card. PTX10016 routers that run Junos OS Release 18.3R1 and later support the PTX10K-LC1104 line card.

Figure 62: PTX10K-LC1104 Port Panel



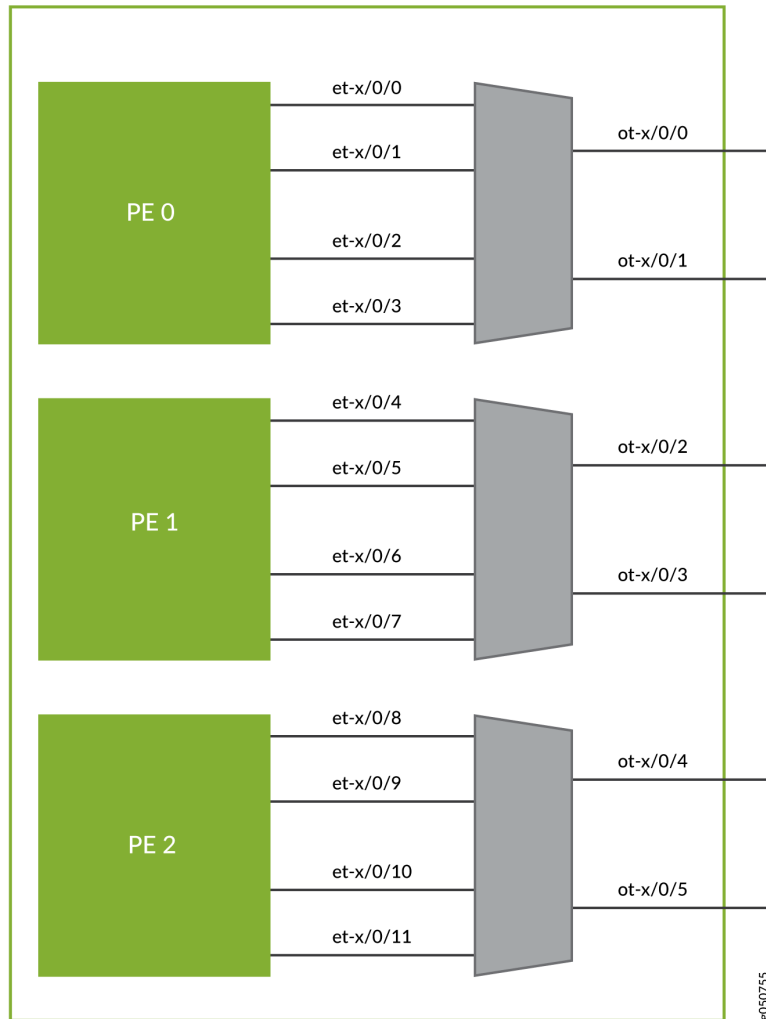
1– Power LED (**PWR**), status LED (**STS**), and offline/online button (**OFF**)

3– Ports with embedded optics

2– Network link and Ethernet link LEDs

Each PTX10K-LC1104 has six physical interfaces (ot- $x/x/x$) that connect to one of three built-in flexible rate optical transponders for a maximum of 24 physical interfaces on a PTX10008 or PTX10016 system. Each transponder connects four 100GbE logical interfaces (et- $x/x/x$) to one of three forwarding ASICs. These forwarding ASICs are responsible for optional MACsec encryption on each 100GbE interface. See [Figure 63 on page 136](#).

Figure 63: PTX10K-LC1104 Interfaces



NOTE: All optical properties are configured under the ot interface. Use the **set interfaces ot-x/x/x optics-options** CLI command to set these options. Perform MACsec configuration on the et interface using the **set security macsec connectivity-association ca-name encryption-algorithm**. Optical transport network (OTN)-related configurations are also done on the et-interface.

Each of the six network ports can operate in one of three modulation formats; see [Table 42 on page 137](#).

Table 42: PTX10K-LC1104 Modulation Formats

Speed (Gbps)	Modulation	Distance
100	DP-QPSK	long haul–4000 km
150	DP-8QAM	regional or metro–2000 km
200	DP-16QAM	metro DCI–1000 km

Compatibility

The Juniper Networks integrated DWDM solution includes integrated 100GbE coherent optics on Juniper Networks QFX Series Switches, MX Series 5G Universal Routing Platforms, PTX Series Packet Transport Routers, and Juniper Networks® BTI Series Packet Optical Platforms optimized for Data Center Interconnect (DCI). As part of the Open Cloud Interconnect (OCI) solution, the PTX10K-LC1104 coherent line card is compatible with many third-party optical products as well as Juniper Networks optical solutions and offerings. The line card is interoperable with the BTI Series Packet Optical Transport UFM6 in 100-Gbps and 200-Gbps modes. It is also compatible with the MX Series MICs and PTX Series PICs in 100-Gbps mode. See [Table 43 on page 137](#).

Table 43: Juniper Networks Compatible Products in 100-Gbps Mode

Platform	Product	Model Information
PTX Series	PTX-5-100-WDM	See the Hardware Compatibility Tool, PTX-5-100-WDM .
MX Series	MIC3-100G-DWDM	See the Hardware Compatibility Tool, MIC3-100G-DWDM .
QFX Series	QFX10K-12C-DWDM	See the Hardware Compatibility Tool, QFX10K-12C-DWDM .

Optical Transmit Specifications

You can connect the line card using single-mode fiber-optic (SMF) and LC connectors. See [Table 44 on page 138](#) and [Table 45 on page 139](#) for the optical transponder specifications.

Table 44: PTX10K-LC1104 Optical Transmit Specifications

Specification	Value
Standards compliance	IEEE 802.3 IEC 60825-1 Class 1
Modulation format	DP-QPSK, DP-8QAM, DP-16QAM
Line rate	DP-QPSK = 136.66 Gbps DP-8QAM = 205 Gbps DP-16QAM= 273.33 Gbps
FEC types	15% or 25% SD-FEC
Channel-plan wavelength range	Extended C-band, 1528.77 nm to 1566.72 nm
Channel-plan frequency range	196.1 THz to 191.35 THz
Channel spacing	37.5 GHz, 50 GHz, and 100 GHz
Channel tunability	12.5 GHz grid. See "1.2-Terabyte Per Second DWDM OTN Module Wavelengths" on page 144.
Optical transmitter output power (on)	-12 to 1.5 dBm, 0.1 dB steps, +/-1 dB accuracy
Optical transmitter output power (off)	≤ -40 dBm
Optical transmitter wavelength accuracy	+/-1.8 GHz
Optical transmitter channel tuning time	≤ 90 seconds across C-band
TX output optical signal-to-noise ratio (OSNR)	≥ 36 dB

Optical Receive Specifications

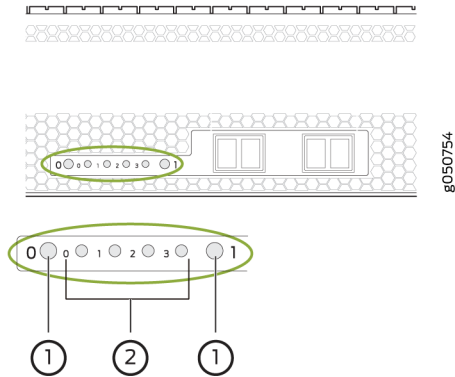
Table 45: PTX10K-LC1104 Optical Receive Specifications

Specification	100G DP-PSK	150G DP-8QAM	200G DP-16QAM
Optical receiver input power range (low Rx OSNR)	−18 dBm to 0 dBm	−18 dBm to 0 dBm	−18 dBm to 0 dBm
Optical receiver input power range (unamplified/dark fiber applications)	−32 dBm to 0 dBm	−27 dBm to 0 dBm	−25 dBm to 0 dBm
Optical receiver damage input power threshold	+17 dBm	+17 dBm	+17 dBm
Optical receiver minimum OSNR (back-to-back), typical	10.3 dB	14.7 dB	17.6 dB
Optical receiver minimum OSNR (back-to-back), worst-case, EOL	11.5 dB	16.0 dB	19.0 dB
Optical receiver chromatic dispersion tolerance	+/− 70,000 ps/nm	+/− 45,000 ps/nm	+/−30,000 ps/nm
Optical receiver PMD tolerance	30 ps mean DGD	20 ps mean DGD	15 ps mean DGD
Optical receiver polarization tracking	100 krad/s	50 krad/s	50 krad/s

Status and Activity LEDs

There are two types of LEDs for the network ports: port LEDs and Ethernet link LEDs. The LEDs for the six physical ports indicate the link state of an ot- interface. There are four LEDs between each port pair that indicate the link state of the associated et- interfaces, (see [Figure 64 on page 140](#)). To determine the link state of the ot- interface, see [Table 46 on page 140](#).

Figure 64: DWDM Port and Ethernet Link State LEDs



1– Port LEDs (ot- interfaces)

2– Ethernet LEDs (et- link interfaces)

Table 46: Network Port Status LEDs (ot Interfaces)

Color	Description
Unlit	The port is not configured.
Solid green	A link is established on the ot interface.
Solid amber	The optical module associated with the port has a fault condition, or the port is configured but the link is down.

You can also determine the configuration of the et interfaces by examining the pattern of the four Ethernet LEDs. See [Table 47 on page 140](#). To determine the link status and of those et interfaces, see [Table 48 on page 141](#).

Table 47: Valid et Interface Link Combinations of Every Two ot Ports

Modulation Format	Aggregate Data Rate	ot Interface Data Rate		et Interface	Configuration
		Ports 0, 2, 4	1, 3, 5		
16-QAM (x2)	4 x 100GbE	200 Gbps	200 Gbps	0, 1, 2, 3	2 independent 200 Gbps 16-QAM

Table 47: Valid et Interface Link Combinations of Every Two of Ports (Continued)

Modulation Format	Aggregate Data Rate	ot Interface Data Rate		et Interface	Configuration
		Ports 0, 2, 4	1, 3, 5		
QPSK and 16-QAM	3 x 100GbE	100 Gbps	200 Gbps	0, 2, 3	Independent QPSK and 16-QAM
16-QAM and QPSK	3 x 100GbE	200 Gbps	100 Gbps	0, 1, 2	Independent QPSK and 16-QAM
8-QAM	3 x 100GbE	150 Gbps	150 Gbps	0, 1, 2	2 Coupled 150 Gbps 8-QAM
QPSK and QPSK	2 x 100GbE	100 Gbps	100 Gbps	0,2	Independent 100 Gbps QPSK

Table 48: Ethernet Link LEDs (et Interfaces)

Color	Description
Unlit	The et- interface is down.
Solid green	The et- interface is up, but there is no activity.
Blinking green	The link is up on the et- interface, and there is activity.

Optical and Ethernet Interface Alarms and Defects

Table 49 on page 142 and Table 50 on page 143 describe the ot and et interface alarms and defects that can occur on the line card and the link status when the alarm or defect occurs.

TIP: You can view optical and Ethernet alarms and defects by using the `show interfaces interface-name extensive` operational-mode CLI command.

Table 49: OT Interface Alarms and Defects

Category	Alarm	Description	Link Status
OTN	Network lane LOS	Loss of signal	Link down
	Network lane LOF	Loss of frame	Link down
	Network lane LOM	Loss of multiframe	Link down
	Network lane OTU-BDI	Backward defect identification	Link down
OTN FEC	FEC degrade (OTU-FEC-DEG)	Forward error correction degraded	Link down if signal degrade or backward FRR thresholds are met
	FEC excessive (OTU-FEC-EXE)	There are uncorrected words and there are errors in the frame header.	Possible link down
Optics and Optical Channel	Module fault	Module fault state	Link down
	Rx modem synch fault	Modem sync detect fault	Link down
	Rx modem loss of lock OTU-BDI	Modem lock fault	Link down
	Rx loss of alignment	Loss of alignment fault	Link down
	Network lane LOS	Lane Rx loss of signal	Alarm
	Modulator bias control loop fail	Modulator bias control loop failed to converge.	Alarm
	ITLA fault	ITLA operation failure	Alarm

Table 49: OT Interface Alarms and Defects (Continued)

Category	Alarm	Description	Link Status
	DAC calibration fault	DAC calibration fault	Alarm
	ADC calibration fault	ACD calibration fault	Alarm

Table 50: et Interface Alarms and Defects

Category	Alarm	Description	Link Status
OTN	LOS	Loss of signal	Alarm
	LOF	Loss of frame	Alarm
	LOM	Loss of multiframe	Alarm
OTN OTU	OTU-AIS	Alarm indication signal or all ones signal	Alarm
	OTU-BDI	Backward defect identification	Alarm
	OTU-IAE	Incoming alignment error	Warning
	OTU-TTIM	Destination access point identifier (DAPI), source access point identifier (SAPI), or both mismatch from expected to received	Warning
	OTU-BIAE	Backward incoming alignment error	Warning
	OTU-TSF	OTU trail signal fail	Warning
	OTU-SSF	OTU server signal fail	Warning
OTN ODU	ODU-AIS	Alarm indication signal or all one signal	Alarm

Table 50: et Interface Alarms and Defects (Continued)

Category	Alarm	Description	Link Status
	ODU-OCI	Open connection error	Alarm
	ODU-LCK	ODU lock triggers for path monitoring and TCM levels 1 through 6	Alarm
	ODU-BDI	Backward defect indication	Alarm
	ODU-TTIM	DAPI or SAPI mismatch from expected to received	Warning
	ODU-IAE	Incoming alignment error	Warning
	ODU-LTC	Loss of tandem connection	Warning
	ODU-CSF	Client signal failure	Warning
	ODU-TSF	Trail signal failure	Warning
	ODU-SSF	Server signal failure	Warning
	ODU-PTIM	Payload type mismatch	Alarm

SEE ALSO

 No Link Title

Understanding the PTX10K-LC1104 Line Card

1.2-Terabyte Per Second DWDM OTN Module Wavelengths

The PTX10K-LC1104 coherent line card and the QFX10000-12C-DWDM line card provide six 200-Gbps coherent MACsec ports with built-in long-reach optics. DWDM channel frequency offsets are 0.02 THz. The QFX10000-12C-DWDM line card is available for the QFX10008 and QFX10016 switch

chassis running Junos OS Release 17.3R1 and later. The PTX10K-LC1104 coherent line card is available for the PTX10008 and PTX10016 routers. See [Table 51 on page 145](#) for the available channel frequencies and wavelengths.

Table 51: DWDM Module Wavelengths

Frequency (THz)	Wavelength (nm)	Offset (GHz)
191.35	1566.72	12.5/50
191.36	1566.62	12.5
191.38	1566.52	12.5
191.39	1566.42	12.5
191.4	1566.31	12.5/50/100
191.41	1566.21	12.5
191.43	1566.11	12.5
191.44	1566.01	12.5
191.45	1565.91	12.5/50
191.46	1565.8	12.5
191.48	1565.7	12.5
191.49	1565.6	12.5
191.5	1565.5	12.5/50/100
191.51	1565.39	12.5

Table 51: DWDM Module Wavelengths (Continued)

Frequency (THz)	Wavelength (nm)	Offset (GHz)
191.53	1565.29	12.5
191.54	1565.19	12.5
191.55	1565.09	12.5/50
191.56	1564.99	12.5
191.58	1564.88	12.5
191.59	1564.78	12.5
191.6	1564.68	12.5/50/100
191.61	1564.58	12.5
191.63	1564.48	12.5
191.64	1564.37	12.5
191.65	1564.27	12.5/50
191.66	1564.17	12.5
191.68	1564.07	12.5
191.69	1563.97	12.5
191.7	1563.86	12.5/50/100

Table 51: DWDM Module Wavelengths (Continued)

Frequency (THz)	Wavelength (nm)	Offset (GHz)
191.71	1563.76	12.5
191.73	1563.66	12.5
191.74	1563.56	12.5
191.75	1563.46	12.5/50
191.76	1563.35	12.5
191.78	1563.25	12.5
191.79	1563.15	12.5
191.8	1563.05	12.5/50/100
191.81	1562.95	12.5
191.83	1562.84	12.5
191.84	1562.74	12.5
191.85	1562.64	12.5/50
191.86	1562.54	12.5
191.88	1562.44	12.5
191.89	1562.33	12.5

Table 51: DWDM Module Wavelengths (Continued)

Frequency (THz)	Wavelength (nm)	Offset (GHz)
191.9	1562.23	12.5/50/100
191.91	1562.13	12.5
191.93	1562.03	12.5
191.94	1561.93	12.5
191.95	1561.83	12.5/50
191.96	1561.72	12.5
191.98	1561.62	12.5
191.99	1561.52	12.5
192	1561.42	12.5/50/100
192.01	1561.32	12.5
192.03	1561.22	12.5
192.04	1561.11	12.5
192.05	1561.01	12.5/50
192.06	1560.91	12.5
192.08	1560.81	12.5

Table 51: DWDM Module Wavelengths (Continued)

Frequency (THz)	Wavelength (nm)	Offset (GHz)
192.09	1560.71	12.5
192.1	1560.61	12.5/50/100
192.11	1560.51	12.5
192.13	1560.4	12.5
192.14	1560.3	12.5
192.15	1560.2	12.5/50
192.16	1560.1	12.5
192.18	1560	12.5
192.188	1559.9	12.5
192.2	1559.79	12.5/50/100
192.21	1559.69	12.5
192.23	1559.59	12.5
192.24	1559.49	12.5
192.25	1559.39	12.5/50
192.26	1559.29	12.5

Table 51: DWDM Module Wavelengths (Continued)

Frequency (THz)	Wavelength (nm)	Offset (GHz)
192.28	1559.19	12.5
192.29	1559.08	12.5
192.3	1558.98	12.5/50/100
192.31	1558.88	12.5
192.33	1558.78	12.5
192.34	1558.68	12.5
192.35	1558.58	12.5/50
192.36	1558.48	12.5
192.38	1558.38	12.5
192.39	1558.27	12.5
192.4	1558.17	12.5/50/100
192.41	1558.07	12.5
192.43	1557.97	12.5
192.44	1557.87	12.5
192.45	1557.77	12.5/50

Table 51: DWDM Module Wavelengths (Continued)

Frequency (THz)	Wavelength (nm)	Offset (GHz)
192.46	1557.67	12.5
192.48	1557.57	12.5
192.49	1557.47	12.5
192.5	1557.36	12.5/50/100
192.51	1557.26	12.5
192.53	1557.16	12.5
192.54	1557.06	12.5
192.55	1556.96	12.5/50
192.56	1556.86	12.5
192.58	1556.76	12.5
192.59	1556.66	12.5
192.6	1556.56	12.5/50/100
192.61	1556.45	12.5
192.63	1556.35	12.5
192.64	1556.25	12.5

Table 51: DWDM Module Wavelengths (Continued)

Frequency (THz)	Wavelength (nm)	Offset (GHz)
192.65	1556.15	12.5/50
192.66	1556.05	12.5
192.68	1555.95	12.5
192.69	1555.85	12.5
192.7	1555.75	12.5/50/100
192.71	1555.65	12.5
192.73	1555.55	12.5
192.74	1555.44	12.5
192.75	1555.34	12.5/50
192.76	1555.24	12.5
192.78	1555.14	12.5
192.79	1555.04	12.5
192.8	1554.94	12.5/50/100
192.81	1554.84	12.5
192.83	1554.74	12.5

Table 51: DWDM Module Wavelengths (Continued)

Frequency (THz)	Wavelength (nm)	Offset (GHz)
192.84	1554.64	12.5
192.85	1554.54	12.5/50
192.86	1554.44	12.5
192.88	1554.34	12.5
192.89	1554.24	12.5
192.9	1554.13	1554.134
192.91	1554.03	12.5
192.93	1553.93	12.5
192.94	1553.83	12.5
192.95	1553.73	12.5/50
192.96	1553.63	12.5
192.98	1553.53	12.5
192.99	1553.43	12.5
193	1553.33	12.5/50/100
193.01	1553.23	12.5

Table 51: DWDM Module Wavelengths (Continued)

Frequency (THz)	Wavelength (nm)	Offset (GHz)
193.03	1553.13	12.5
193.04	1553.03	12.5
193.05	1552.93	12.5/50
193.06	1552.83	12.5
193.08	1552.73	12.5
193.09	1552.63	12.5
193.1	1552.52	12.5/50/100
193.11	1552.42	12.5
193.13	1552.32	12.5
193.14	1552.22	12.5
193.15	1552.12	12.5/50
193.16	1552.02	12.5
193.18	1551.92	12.5
193.19	1551.82	12.5
193.2	1551.72	12.5/50/100

Table 51: DWDM Module Wavelengths (Continued)

Frequency (THz)	Wavelength (nm)	Offset (GHz)
193.21	1551.62	12.5
193.23	1551.52	12.5
193.24	1551.42	12.5
193.25	1551.32	12.5/50
193.26	1551.22	12.5
193.28	1551.12	12.5
193.29	1551.02	12.5
193.3	1550.92	12.5/50/100
193.31	1550.82	12.5
193.33	1550.72	12.5
193.34	1550.62	12.5
193.35	1550.52	12.5/50
193.36	1550.42	12.5
193.38	1550.32	12.5
193.39	1550.22	12.5

Table 51: DWDM Module Wavelengths (Continued)

Frequency (THz)	Wavelength (nm)	Offset (GHz)
193.4	1550.12	12.5/50/100
193.41	1550.02	12.5
193.43	1549.92	12.5
193.44	1549.82	12.5
193.45	1549.72	12.5/50
193.46	1549.62	12.5
193.48	1549.52	12.5
193.49	1549.42	12.5
193.5	1549.32	12.5/50/100
193.51	1549.22	12.5
193.53	1549.12	12.5
193.54	1549.02	12.5
193.55	1548.92	12.5/50
193.56	1548.82	12.5
193.58	1548.72	12.5

Table 51: DWDM Module Wavelengths (Continued)

Frequency (THz)	Wavelength (nm)	Offset (GHz)
193.59	1548.62	12.5
193.6	1548.52	12.5/50/100
193.61	1548.42	12.5
193.63	1548.32	12.5
193.64	1548.22	12.5
193.65	1548.12	12.5/50
193.66	1548.02	12.5
193.68	1547.92	12.5
193.69	1547.82	12.5
193.7	1547.72	12.5/50/100
193.71	1547.62	12.5
193.73	1547.52	12.5
193.74	1547.42	12.5
193.75	1547.32	12.5/50
193.76	1547.22	12.5

Table 51: DWDM Module Wavelengths (Continued)

Frequency (THz)	Wavelength (nm)	Offset (GHz)
193.78	1547.12	12.5
193.79	1547.02	12.5
193.8	1546.92	12.5/50/100
193.81	1546.82	12.5
193.83	1546.72	12.5
193.84	1546.62	12.5
193.85	1546.52	12.5/50
193.86	1546.42	12.5
193.88	1546.32	12.5
193.89	1546.22	12.5
193.9	1546.12	12.5/50/100
193.91	1546.02	12.5
193.93	1545.92	12.5
193.94	1545.82	12.5
193.95	1545.72	12.5/50

Table 51: DWDM Module Wavelengths (Continued)

Frequency (THz)	Wavelength (nm)	Offset (GHz)
193.96	1545.62	12.5
193.98	1545.52	12.5
193.99	1545.42	12.5
194	1545.32	12.5/50/100
194.01	1545.22	12.5
194.03	1545.12	12.5
194.04	1545.02	12.5
194.05	1544.92	12.5/50
194.06	1544.82	12.5
194.08	1544.73	12.5
194.09	1544.63	12.5
194.1	1544.53	12.5/50/100
194.11	1544.43	12.5
194.13	1544.33	12.5
194.14	1544.23	12.5

Table 51: DWDM Module Wavelengths (Continued)

Frequency (THz)	Wavelength (nm)	Offset (GHz)
194.15	1544.13	12.5/50
194.16	1544.03	12.5
194.18	1543.93	12.5
194.19	1543.83	12.5
194.2	1543.73	12.5/50/100
194.21	1543.63	12.5
194.23	1543.53	12.5
194.24	1543.43	12.5
194.25	1543.33	12.5/50
194.26	1543.23	12.5
194.28	1543.14	12.5
194.29	1543.04	12.5
194.3	1542.94	12.5/50/100
194.31	1542.84	12.5
194.33	1542.74	12.5

Table 51: DWDM Module Wavelengths (Continued)

Frequency (THz)	Wavelength (nm)	Offset (GHz)
194.34	1542.64	12.5
194.35	1542.54	12.5/50
194.36	1542.44	12.5
194.38	1542.34	12.5
194.39	1542.24	12.5
194.4	1542.14	12.5/50/100
194.41	1542.04	12.5
194.43	1541.94	12.5
194.44	1541.85	12.5
194.45	1541.75	12.5/50
194.46	1541.65	12.5
194.48	1541.55	12.5
194.49	1541.45	12.5
194.5	1541.35	12.5/50/100
194.51	1541.25	12.5

Table 51: DWDM Module Wavelengths (Continued)

Frequency (THz)	Wavelength (nm)	Offset (GHz)
194.53	1541.15	12.5
194.54	1541.05	12.5
194.55	1540.95	12.5/50
194.56	1540.85	12.5
194.58	1540.76	12.5
194.59	1540.66	12.5
194.6	1540.56	12.5/50/100
194.61	1540.46	12.5
194.63	1540.36	12.5
194.64	1540.26	12.5
194.65	1540.16	12.5/50
194.66	1540.06	12.5
194.68	1539.96	12.5
194.69	1539.87	12.5
194.7	1539.77	12.5/50/100

Table 51: DWDM Module Wavelengths (Continued)

Frequency (THz)	Wavelength (nm)	Offset (GHz)
194.71	1539.67	12.5
194.73	1539.57	12.5
194.74	1539.47	12.5
194.75	1539.37	12.5/50
194.76	1539.27	12.5
194.78	1539.17	12.5
194.79	1539.07	12.5
194.8	1538.98	12.5/50/100
194.81	1538.88	12.5
194.83	1538.78	12.5
194.84	1538.68	12.5
194.85	1538.58	12.5/50
194.86	1538.48	12.5
194.88	1538.38	12.5
194.89	1538.29	12.5

Table 51: DWDM Module Wavelengths (Continued)

Frequency (THz)	Wavelength (nm)	Offset (GHz)
194.9	1538.19	12.5/50/100
194.91	1538.09	12.5
194.93	1537.99	12.5
194.94	1537.89	12.5
194.95	1537.79	12.5/50
194.96	1537.69	12.5
194.98	1537.59	12.5
194.99	1537.5	12.5
195	1537.4	12.5/50/100
195.01	1537.3	12.5
195.03	1537.2	12.5
195.04	1537.1	12.5
195.05	1537	12.5/50
195.06	1536.9	12.5
195.08	1536.8	12.5

Table 51: DWDM Module Wavelengths (Continued)

Frequency (THz)	Wavelength (nm)	Offset (GHz)
195.09	1536.7	12.5
195.1	1536.6	12.5/50/100
195.11	1536.51	12.5
195.13	1536.41	12.5
195.14	1536.31	12.5
195.15	1536.22	12.5/50
195.16	1536.12	12.5
195.18	1536.02	12.5
195.19	1535.92	12.5
195.2	1535.82	12.5/50/100
195.21	1535.72	12.5
195.23	1535.63	12.5
195.24	1535.53	12.5
195.25	1535.43	12.5/50
195.26	1535.33	12.5

Table 51: DWDM Module Wavelengths (Continued)

Frequency (THz)	Wavelength (nm)	Offset (GHz)
195.28	1535.23	12.5
195.29	1535.13	12.5
195.3	1535.03	12.5/50/100
195.31	1534.94	12.5
195.33	1534.84	12.5
195.34	1534.74	12.5
195.35	1564.64	12.5/50
195.36	1534.55	12.5
195.38	1534.45	12.5
195.39	1534.35	12.5
195.4	1534.25	12.5/50/100
195.41	1534.15	12.5
195.43	1534.05	12.5
195.44	1533.96	12.5
195.45	1533.86	12.5/50

Table 51: DWDM Module Wavelengths (Continued)

Frequency (THz)	Wavelength (nm)	Offset (GHz)
195.46	1533.76	12.5
195.48	1533.66	12.5
195.49	1533.56	12.5
195.5	1533.47	12.5/50/100
195.51	1533.37	12.5
195.53	1533.27	12.5
195.54	1533.17	12.5
195.55	1533.07	12.5/50
195.56	1532.98	12.5
195.58	1532.88	12.5
195.59	1532.78	12.5
195.6	1532.68	12.5/50/100
195.61	1532.58	12.5
195.63	1532.49	12.5
195.64	1532.39	12.5

Table 51: DWDM Module Wavelengths (Continued)

Frequency (THz)	Wavelength (nm)	Offset (GHz)
195.65	1532.29	12.5/50
195.66	1532.19	12.5
195.68	1532.09	12.5
195.69	1532	12.5
195.7	1531.9	12.5/50/100
195.71	1531.8	12.5
195.73	1531.7	12.5
195.74	1531.61	12.5
185.75	1531.51	12.5/50
185.76	1531.41	12.5
195.78	1531.31	12.5
195.79	1531.21	12.5
195.8	1531.12	12.5/50/100
195.81	1531.02	12.5
195.83	1530.92	12.5

Table 51: DWDM Module Wavelengths (Continued)

Frequency (THz)	Wavelength (nm)	Offset (GHz)
195.84	1530.82	12.5
195.85	1530.73	12.5/50
195.86	1530.63	12.5
195.88	1530.53	12.5
195.89	1530.43	12.5
195.9	1530.33	12.5/50/100
195.91	1530.34	12.5
195.93	1530.24	12.5
195.94	1530.04	12.5
195.95	1529.94	12.5/50
195.96	1529.85	12.5
195.98	1529.75	12.5
195.99	1529.65	12.5
196	1529.55	12.5/50/100
196.01	1529.46	12.5

Table 51: DWDM Module Wavelengths (Continued)

Frequency (THz)	Wavelength (nm)	Offset (GHz)
196.03	1529.36	12.5
196.04	1529.26	12.5
196.05	1529.16	12.5/50
196.06	1529.07	12.5
196.08	1528.97	12.5
196.09	1528.87	12.5
196.1	1528.77	12.5/50/100

PTX10K-LC1105 Line Card

IN THIS SECTION

- [Overview | 170](#)
- [Network Ports | 171](#)
- [Channelizing 40-Gigabit Ethernet Ports | 171](#)
- [Power and Status LEDs | 173](#)
- [Port Status and Activity LEDs | 174](#)

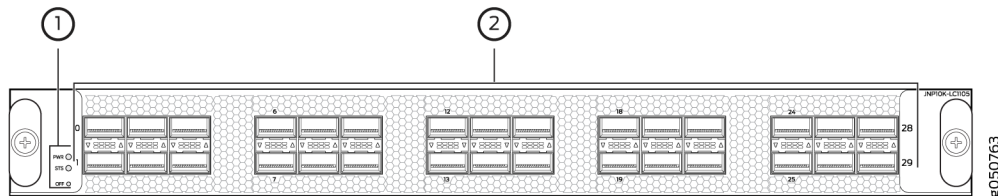
Overview

The PTX10K-LC1105 line card is designed to provide secure Ethernet communication across high-speed links. The card consists of thirty 28-Gbps QSFP+ Pluggable Solution (QSFP28) ports that are MACsec

capable. The ports support speeds of 100 Gbps or 40 Gbps and you can configure the port speed through the CLI. See [Figure 65 on page 171](#).

The PTX10008 and PTX10016 routers that run Junos OS Release 17.4R1-S1 and later support the PTX10K-LC1105 line card.

Figure 65: PTX10K-LC1105 Port Panel



1– Power LED (**PWR**), status LED (**STS**), and offline/online (**OFF**) button

2– Network ports

Network Ports

Each of the 30 QSFP28 ports can operate as:

- 100GbE ports when you use QSFP28 optical transceivers.
- 40GbE ports when you use QSFP+ optical transceivers.

On the PTX10K-LC1105, the ports are enabled by default.

To change the mode, use the Junos OS operational command `set chassis fpc slot-number pic 0 port port number channelization-speed speed`.

Channelizing 40-Gigabit Ethernet Ports

Each of the 40-Gigabit Ethernet ports on the PTX10K-LC1105 line card can be channelized into four 10-Gigabit Ethernet, or channels. When ports are in channelization mode, the fourth port on each Packet Forwarding Engine is disabled, and the remaining four ports that are mapped to the same Packet Forwarding Engine can be used as either 4x10-Gigabit Ethernet, 40-Gigabit Ethernet, or 100-Gigabit Ethernet ports. The channelization mode works independently for each of the Packet Forwarding Engines on the PTX10K-LC1105 line card. See [Table 52 on page 172](#) for the maximum port configurations.

Table 52: Maximum Port Configuration

Port Speed	Nonchannelized Mode (Mode D)	Channelized Mode (Mode A)
100 Gbps	30 or	24 or
40 Gbps	30	24 or
10 Gbps	0	96

The port behavior in the PTX10K-LC1105 line card is tied to the ASIC associated with the port. You must configure each port individually, in order to channelize a 40-Gigabit Ethernet port to four independent 10-Gigabit Ethernet ports. For example, ASIC PE0 maps to ports 0, 2, 4, 6, and 8. The fourth port, port 6, is disabled. See [Table 53 on page 172](#) for the list of available ports and the associated ASIC mapping in [Figure 65 on page 171](#) to locate the available and disabled ports.

NOTE: If you change the channelization mode (mode D to mode A or mode A to mode D), the new port speed configuration does not cause an FPC to reboot automatically, but it triggers an FPC need bounce alarm. To ensure that the new port speed configuration takes effect, you must manually reboot the FPC. The alarm is cleared when you manually reboot the FPC or delete the new port speed configuration.

NOTE: When port speeds are changed manually from one setting to another, or when the interface is deactivated, the `show interface interface-name` command shows the error `Device interface-name not found` for a brief interval. Ensure that the transceiver is in a working condition. The interface comes up subsequently.

Table 53: Port Mapping for Channelization

ASIC	Available Ports	Disabled Port
PE0	0, 2, 4, 8	6
PE1	1, 3, 5, 9	7

Table 53: Port Mapping for Channelization (Continued)

ASIC	Available Ports	Disabled Port
PE2	10, 12, 14, 18	16
PE3	11, 13, 15, 19	17
PE4	20, 22, 24, 28	26
PE5	21, 23, 25, 29	27

Power and Status LEDs

The two LEDs to the left of the network ports indicate the power (**PWR**) and status (**STS**) for the line card. See [Table 54 on page 173](#) and [Table 55 on page 173](#).

Table 54: Power LED

Color	State	Description
Unlit	Off	There is no power to the line card.
Green	On steadily	The line card has power.
Yellow or amber	Blinking	The line card has a power fault.

Table 55: Status LED

Color	State	Description
Unlit	Off	The line card is offline or disabled.
Green	On steadily	The line card is online.

Table 55: Status LED (Continued)

Color	State	Description
Yellow or amber	On steadily	The line card is booting.
	Blinking	The line card has a fault condition or alarm.
	Slow blink or blip	The beacon function is enabled.

Port Status and Activity LEDs

Each QSFP28 port has a bicolored up or down LED indicator that shows port status and link activity. See [Figure 66 on page 174](#) and [Table 56 on page 174](#).

Figure 66: Indicators for QSFP28 Ports on PTX10K-LC1105 Line Cards

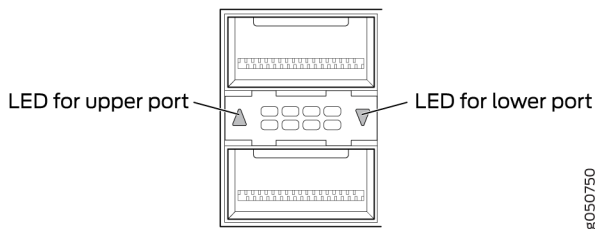


Table 56: Network Port Status and Activity LEDs on a PTX10K-LC1105 Line Card

Color	State	Description
Unlit	Off	The port is administratively disabled, there is no power, the link is down, or a transceiver is not present.
Green	On steadily	A link is established but there is no activity.
	Blinking	A link is up and there is activity.

Table 56: Network Port Status and Activity LEDs on a PTX10K-LC1105 Line Card (Continued)

Color	State	Description
Yellow or amber	Slow blink or blip	The beacon function is enabled on the port.
	Blinking	A single LED blinking indicates an interface fault.

PTX10K-LC1201-36CD Line Card

IN THIS SECTION

- [Overview | 175](#)
- [Network Ports | 177](#)
- [Channelization | 177](#)
- [Bandwidth Support | 179](#)
- [Network LEDs | 179](#)
- [Line Card Status LEDs | 180](#)

The PTX10K-LC1201-36CD line card (Model Number: JNP10K-LC1201) is a 36-port line card that provides a line rate throughput of 14.4 Tbps. The line card has 36 QSFP56-DD ports capable of supporting 400-Gbps speed (see [Figure 67 on page 176](#)). You can channelize the ports to operate at 200-Gbps, 100-Gbps, 50-Gbps, 25-Gbps, or 10-Gbps speed by using breakout cables.

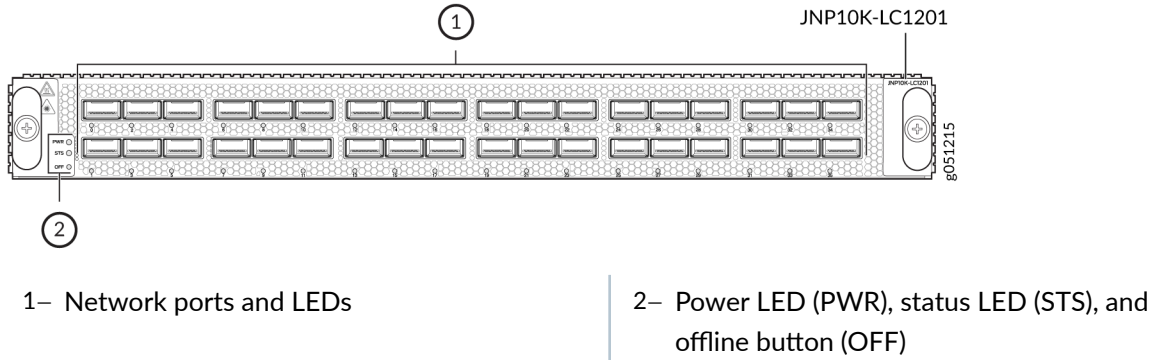
The line card is designed to operate using the newer Routing Engines, the JNP10004-SF3 switch fabric, the JNP10008-SF3 switch fabric, or the JNP10016-SF3 switch fabric; the JNP10K-PWR-AC2, JNP10K-PWR-AC3, or JNP10K-PWR-DC2 power supply; the JNP10004-FAN2, the JNP10008-FAN2, or the JNP10016-FAN fan tray; and the JNP10004-FTC2, the JNP10008-FTC2, or the JNP10016-FTC2 fan tray controller. These components require Junos OS Evolved.

Overview

The PTX10K-LC1201-36CD line card houses Packet Forwarding Engine based on Juniper Networks' custom ASICs to deliver a 400GbE solution for data centers.

You can install the PTX10K-LC1201-36CD line card in the PTX10004, PTX10008, and PTX10016 chassis horizontally at the front of the chassis.

Figure 67: PTX10K-LC1201-36CD Port Panel



PTX10004 routers running Junos OS Evolved Release 20.3R1 with Junos Continuity and later support the PTX10K-LC1201-36CD line card. PTX10008 routers running Junos OS Evolved Release 19.4R1-S1 and later support the PTX10K-LC1201-36CD line card. PTX10016 routers running Junos OS Evolved Release 21.2R2 and later support the PTX10K-LC1201-36CD line card. The PTX10K-LC1201-36CD line card interoperates with the PTX10K-LC1202-36MR line card on a PTX10004, PTX10008, or PTX10016 router (see [Table 57 on page 176](#)).

Table 57: Components Required for the PTX10K-LC1201-36CD Line Cards

Component (Field Replaceable Unit)	Part Number for the PTX10004	Part Number for the PTX10008	Part Number for the PTX10016
Switch fabric	JNP10004-SF3	JNP10008-SF3	JNP10016-SF3
RCB	JNP10K-RE1-E, JNP10K-RE1-128G-E, or JNP10K-RE1-ELT	JNP10K-RE1-E, JNP10K-RE1-ELT, JNP10K-RE1-E128, or JNP10K-RE2-E128	JNP10K-RE1-E, JNP10K-RE1-ELT or JNP10K-RE1-E128
Fan tray	JNP10004-FAN2	JNP10008-FAN2	JNP10016-FAN2
Fan tray controller	JNP10004-FTC2	JNP10008-FTC2	JNP10016-FTC2

Table 57: Components Required for the PTX10K-LC1201-36CD Line Cards (Continued)

Component (Field Replaceable Unit)	Part Number for the PTX10004	Part Number for the PTX10008	Part Number for the PTX10016
Power supply	JNP10K-PWR-AC2, JNP10K-PWR-AC3, or JNP10K-PWR-DC2	JNP10K-PWR-AC2, JNP10K-PWR-AC3, or JNP10K-PWR-DC2	JNP10K-PWR-AC2, JNP10K-PWR-AC3, or JNP10K-PWR-DC2

Network Ports

The QSFP56-DD ports support:

- 400GbE transceivers (QSFP56-DD)
- 400GbE active optic cables (QSFP56-DD AOCs)
- 4 x 100GbE transceivers (QSFP56-DD)
- 2 x 100GbE transceivers (QSFP28-DD)
- 100GbE transceivers (QSFP28)
- 100GbE AOCs (QSFP28)
- 40GbE transceivers (QSFP+)
- 40GbE to 10GbE QSA (Junos OS Release 20.2R1 and later)

Channelization

All 36 ports of the PTX10K-LC1201-36CD line card default to 400GbE. You can either set all the ports to a specific speed and channelization or you can channelize each port individually. The CLI syntax to channelize a port on the PTX10K-LC1201-36CD is release dependent.

For software releases from Junos OS Evolved Release 19.4R1-S1 to Junos OS Evolved Release 20.1R2:

1. Use the `pic-mode` and `speed` options on the Junos OS Evolved operational `set chassis` command:

```
user@host>set chassis fpc slot slot-number pic 0 pic-mode speed 400g|200g|100g|50g|40g|25g|10g
```

In this example, `fpc slot` represents the line card slots. There is a single PIC in the PTX10K-LC1201-36CD; it is always numbered zero. The `pic-mode` option indicates you are configuring all of

ports on the PIC and not an individual port. With the speed options, you can configure 100-Gbps or 40-Gbps speed on all 36 ports, or you can configure four 10-Gbps channels on each of the 36 ports.

For example, to set 100-Gbps speed on all ports in slot 2:

```
user@host> set chassis fpc 2 pic 0 pic-mode speed 100g
```

To individually configure a port, you need to specify both the speed and number of subports (channels).

```
user@host> set chassis fpc 0-7 pic 0 port 0-35 speed 400g|200g|100g|50g|40g|25g|10g number-of-subports 1-8
```

For example, to channelize port 15 in slot 0 to 4 downstream 100GbE interfaces:

```
user@host> set chassis fpc 0 pic 0 port 15 speed 100g number-of-subports 4
```

The resulting interfaces would be:

```
et-0/0/15:0
et-0/0/15:1
et-0/0/15:2
et-0/0/15:3
```

NOTE: If you do not specify the `number-of-subports` when configuring an individual port, the system will default to a value of 1. The same example, without the `number-of-subports` option, would then result in one downstream 100GbE interface.

NOTE: For software releases Junos OS Evolved Release 20.1R2 and later, the `speed` and `number-of-subports` options are in the interfaces hierarchy. For example, to channelize port 15 in slot 0 to 4 downstream 100GbE interfaces:

```
[edit-interfaces]
user@host> et-0/0/15
{speed 100g;
number-of-subports 4;
```

```

}
et-0/0/15:0 {unit 0}
et-0/0/15:1 {unit 0}
et-0/0/15:2 {unit 0}
et-0/0/15:3 {unit 0}

```

After saving and committing the changes, the resulting interfaces would be:

```

et-0/0/15:0
et-0/0/15:1
et-0/0/15:2
et-0/0/15:3

```

Bandwidth Support

[Table 58 on page 179](#) explains the bandwidth supported by each PTX10K-LC1201-36CD line card.

Table 58: PTX10K-LC1201-36CD Bandwidth

Number of Switch Fabric Cards Used	Bandwidth per Slot Without Fabric Redundancy
6	14.4 Tbps
5	12 Tbps
4	9.6 Tbps
3	7.2 Tbps

Network LEDs

Each network port has a single tricolored LED that indicates link activity and status. The red, amber, or green LED has different interpretations depending on whether the port is channelized, not channelized, or whether the beacon is activated (see [Table 59 on page 180](#)). If the beacon feature is activated on the port, the port blinks.

Table 59: PTX10K-LC1201-36CD Network LEDs

Port Status	Normal State	Description
Nonchannelized	Unlit, off	A transceiver is not present in the port or the link is down because of a loss of signal.
	Green, on steadily	A link is established.
	Amber, on steadily	The link is down because of a remote error or because the port was disabled through the CLI.
	Red, on steadily	The link is down because of a hardware failure or a local error.
Channelized	Unlit, off	All channels are down because of loss of signal.
	Green, on steadily	A link is established and all channels are up.
	Amber, on steadily	Applies to all other cases.
	Red, on steadily	The port has a hardware failure.

Line Card Status LEDs

The line card has a power (**PWR**) LED and a status (**STS**) LED (see [Table 60 on page 180](#)).

Table 60: Line Card Status LEDs

LED	State	LED Indication	Beacon/Port Location On
Power PWR	Power is not present.	Off	Off
	The line card has power and is operating correctly.	Green, on steadily	Green, on steadily

Table 60: Line Card Status LEDs (Continued)

LED	State	LED Indication	Beacon/Port Location On
	The line card has a fault condition.	Red, on steadily	Red, on steadily
Status STS	The line card is disabled or offline.	Off	Off
	The line card is online and operating correctly.	Green, on steadily	Green, blinking
	The line card is booting.	Green, blinking	Green, blinking
	The line card has a fault condition.	Red, on steadily	Red, blinking

PTX10K-LC1202-36MR Line Card

IN THIS SECTION

- Overview | **181**
- Components Required for PTX10K-LC1202-36MR | **182**
- Network Ports and Channelization | **183**
- Bandwidth Support | **184**
- Network LEDs | **185**
- Line Card Status LEDs | **186**

Overview

The PTX10K-LC1202-36MR line card (Model Number: JNP10K-LC1202) is a 36-port line card that provides a line rate throughput of 4.8 Tbps. The line card has thirty-two QSFP28 ports, each capable of supporting a maximum speed of 100 Gbps, and four QSFP56-DD ports, each capable of supporting a maximum speed of 400 Gbps (see [Figure 68 on page 182](#)).

In a pure 100-Gbps port speed configuration, the line card supports a throughput of 3.6 Tbps (each of the 36 ports runs at 100-Gbps speed).

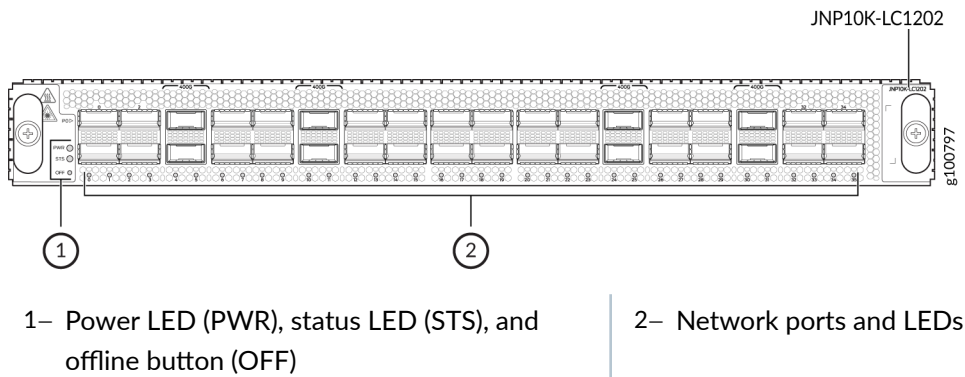
In a mixed-speed configuration of 100 Gbps and 400 Gbps, the line card supports a line rate throughput of 4.8 Tbps (thirty-two 100-Gbps ports and four 400-Gbps ports).

The line card is designed to operate using the newer Routing Engines, the JNP10004-SF3 switch fabric, the JNP10008-SF3 switch fabric, or the JNP10016-SF3 switch fabric; the JNP10K-PWR-AC2 or JNP10K-PWR-DC2 power supply; the JNP10004-FAN2, the JNP10008-FAN2, or JNP10016-FAN fan tray; and the JNP10004-FTC2, the JNP10008-FTC2, or the JNP10016-FTC2 fan tray controller. These components require Junos OS Evolved.

The PTX10K-LC1202-36MR line card houses Packet Forwarding Engines based on Juniper Networks' custom ASICs. The line card has two custom ASICs, each hosting two Packet Forwarding Engines. The line card supports a maximum throughput of 1.2 Tbps per Packet Forwarding Engine.

You can install the PTX10K-LC1202-36MR line card in the PTX10004, PTX10008, and PTX10016 chassis horizontally at the front of the chassis.

Figure 68: PTX10K-LC1202-36MR Port Panel



Components Required for PTX10K-LC1202-36MR

PTX10004 routers running Junos OS Evolved Release 20.3R1 with Junos Continuity and later support the PTX10K-LC1202-36MR line card. PTX10008 routers running Junos OS Evolved Release 20.3R1 and later (with Junos Continuity) support the PTX10K-LC1202-36MR line card. PTX10016 routers running Junos OS Evolved Release 21.2R2 and later support the PTX10K-LC1202-36MR line card. The PTX10K-LC1202-36MR line card interoperates with the PTX10K-LC1201-36CD line card on a PTX10004, PTX10008, or PTX10016 router.

See [Table 61 on page 183](#) for the required hardware components for PTX10K-LC1202-36MR line cards.

Table 61: Components Required for the PTX10K-LC1202-36MR Line Cards

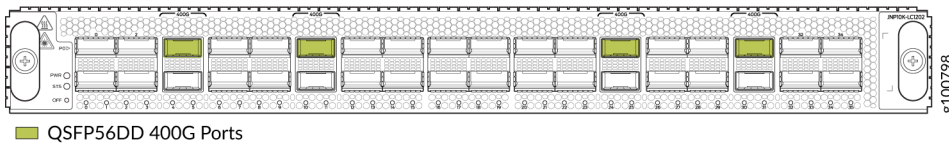
Component (FRU)	Part Number for the PTX10004	Part Number for the PTX10008	Part Number for the PTX10016
Switch fabric	JNP10004-SF3	JNP10008-SF3	JNP10016-SF3
RCB	JNP10K-RE1-E, JNP10K-RE1-E128, or JNP10K-RE1-ELT	JNP10K-RE1-E, JNP10K-RE1-ELT, JNP10K-RE1-E128, or JNP10K-RE2-E128	JNP10K-RE1-E, JNP10K-RE1-ELT, or JNP10K-RE1-E128
Fan tray	JNP10004-FAN2	JNP10008-FAN2	JNP10016-FAN2
Fan tray controller	JNP10004-FTC2	JNP10008-FTC2	JNP10016-FTC2
Power supply	JNP10K-PWR-AC2 or JNP10K-PWR-DC2	JNP10K-PWR-AC2 or JNP10K-PWR-DC2	JNP10K-PWR-AC2 or JNP10K-PWR-DC2

Network Ports and Channelization

On the PTX10K-LC1202-36MR line card, the ports 4, 10, 24, and 30 are 400GbE (QSFP56-DD) ports, while the rest are 100GbE (QSFP28) ports.

Figure 69 on page 183 shows the 400GbE ports highlighted.

Figure 69: PTX10K-LC1202-36MR—Network Ports



By using breakout cables, you can channelize the PTX10K-LC1202-36MR ports.

The QSFP56-DD ports (ports 4, 10, 24, and 30) on the line card support the following transceivers:

- 1x400GbE transceivers (QSFP56-DD)
- 4x100GbE transceivers (QSFP56-DD)

- 2x100GbE transceivers (QSFP28-DD)
- 8x25GbE transceivers (QSFP28-DD)
- 1x100GbE transceivers (QSFP28)
- 4x25GbE transceivers (QSFP28)
- 4x10GbE transceivers (QSFP+)
- 40GbE to 10GbE QSA, starting in Junos OS Evolved Release 20.4R1 and later.

The QSFP28 ports 0, 2, 5 through 9, 11 through 18, 20, 22, 23, 25 through 29, and 31 through 35 on the line card support the following transceivers:

- 1x100GbE transceivers (QSFP28)
- 4x25GbE transceivers (QSFP28)
- 4x10GbE transceivers (QSFP+)

The QSFP28 ports 1, 3, 19, and 21 on the line card support the the 1x100GbE QSFP28 transceivers.

NOTE: The ports 1, 3, 19, and 21 must be configured as unused if the preceding ports (0, 2, 18, and 20) are not in 100-Gbps mode. This means, of the 36 ports on the PTX10K-LC1202-36MR line card, only 32 ports are available to be configured as 4x25 Gbps and 4x10 Gbps ports.

See the [Port Checker](#) tool to see the supported port speeds.

You can configure port speeds at the interface level using the CLI command `set interfaces interface-name number-of-sub-ports number-of-sub-ports .`

Bandwidth Support

[Table 62 on page 184](#) explains the bandwidth supported by each PTX10K-LC1202-36MR line card.

Table 62: PTX10K-LC1202-36MR Bandwidth

Number of Switch Fabric Cards Used	Bandwidth per Slot Without Fabric Redundancy
6	4.8 Tbps
5	4 Tbps

Table 62: PTX10K-LC1202-36MR Bandwidth (Continued)

Number of Switch Fabric Cards Used	Bandwidth per Slot Without Fabric Redundancy
4	3.2 Tbps
3	2.4 Tbps

Network LEDs

Each network port has a single tricolored LED that indicates link activity and status. The red, amber, or green LED has different interpretations depending on whether the port is channelized or not channelized, or whether the beacon feature is activated (see [Table 63 on page 185.](#)) If the beacon feature is activated on the port, the port blinks.

Table 63: PTX10K-LC1202-36MR Network LEDs

Port Status	State	Description
Nonchannelized	Unlit, off	A transceiver is not present in the port, or the link is down because of a loss of signal.
	Green, on steadily	A link is established.
	Amber, on steadily	The link is down because of a remote error or because the port was disabled through the CLI.
	Red, on steadily	The link is down because of a hardware failure or a local error.
Channelized	Unlit, off	All channels are down because of loss of signal.
	Green, on steadily	A link is established and all channels are up.
	Amber, on steadily	Applies to all other cases.

Table 63: PTX10K-LC1202-36MR Network LEDs (Continued)

Port Status	State	Description
	Red, on steadily	The port has a hardware failure.

Line Card Status LEDs

The line card has a power (**PWR**) LED and a status (**STS**) LED (see [Table 64 on page 186](#)).

Table 64: Line Card Status LEDs

LED	State	LED Indication	Beacon/Port Location On
Power PWR	Power is not present.	Off	Off
	The line card has power and is operating correctly.	Green, on steadily	Green, on steadily
	The line card has a fault condition.	Red, on steadily	Red, on steadily
Status STS	The line card is disabled or offline.	Off	Off
	The line card is online and operating correctly.	Green, on steadily	Green, blinking
	The line card is booting.	Green, blinking	Green, blinking
	The line card has a fault condition.	Red, on steadily	Red, blinking

QFX10000-60S-6Q Line Card

IN THIS SECTION

- [Hardware Features | 187](#)
- [Port Groups | 189](#)
- [Channelization of 40GbE Ports | 190](#)
- [Using Copper and Fiber SFP Transceivers | 190](#)
- [SFP+ Status and Activity LEDs | 191](#)
- [QSFP+ and QSFP28 Status and Activity LEDs | 192](#)

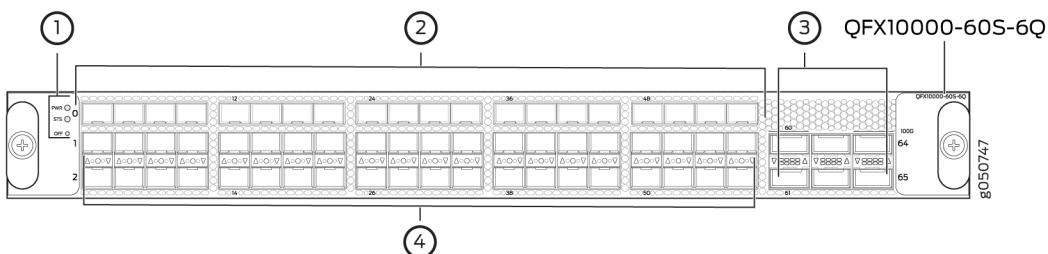
Hardware Features

The QFX10000-60S-6Q line card consists of 60 small form-factor pluggable plus (SFP+) ports that support 10-Gbps or 1-Gbps port speed, 2 dual-speed QSFP28 ports that support either 40-Gbps or 100-Gbps port speed, and 4 QSFP+ ports that support 40-Gbps port speed. All of the QSFP and SFP+ ports are configured to 10 Gbps by default. The QSFP28 ports are configured as 40-Gbps speed ports by default, but port **60** and port **64** are dual-speed ports and can be configured to support either 10GbE or 40GbE optical transceivers. Ports **60** and **64** can also be configured to support 100GbE optical transceivers. See the [Hardware Compatibility Tool](#) for details of supported optical transceivers. See [Figure 70 on page 187](#).

The QFX10000-60S-6Q line card is supported on Junos OS Release 19.1R1 and later.

NOTE: Junos OS Release 19.1R1 does not support 1GbE on the 10GbE SFP+ ports.

Figure 70: QFX10000-60S-6Q Port Panel



1– Power LED (PWR), status LED (STS), and offline/online (OFF) button	3– QSFP28 ports, QSFP+ ports, and port groups
2– SFP+ ports	

Each QSFP28 port (**60** and **64**) controls a port group and can be configured as a:

- 100GbE port by using QSFP28 optical transceivers. The interface speeds are configured by port group. When a QSFP28 transceiver is inserted into one of the QSFP28 ports marked with a fine black line above the port (**60** or **64**) and the port is configured for 100GbE, the two adjacent ports are disabled and the QSFP28 port is enabled for 100GbE. When you configure port **60** for 100 Gbps, ports **61** and **62** are disabled; when you configure port **64** for 100 Gbps, ports **63** and **65** are disabled.
- 40GbE port by using QSFP+ optical transceivers. The default speed is 10 Gbps.
- 10GbE port by using breakout cables and attached optical transceivers. When configured for channelization, the system converts the 40GbE port into four independent 10GbE ports (or channels). Use the `set chassis fpc slot slot-number pic slot slot-number port port-number speed speed` command to change the port speed.

Each QSFP+ port (**61**, **62**, **63**, and **65**) is part of a port group and is controlled by one of the associated QSFP28 ports (**60** or **64**). If a QSFP28 port operates at 40-Gbps speed, then each of the QSFP+ ports can be configured as a:

- 40GbE port by using QSFP+ optical transceivers. The default speed is 10 Gbps.
- 10GbE port by using breakout cables with attached optical transceivers. When configured for channelization, the system converts the 40GbE port into four independent 10GbE ports (or channels). Use the `set chassis fpc slot slot-number pic slot slot-number port port-number speed speed` command to change the port speed.

You can configure each SFP+ port (**0** through **59**) as a 10GbE port by using SFP+ optical transceivers. The default speed is 10 Gbps.

You can install copper SFP transceivers only on ports located in the lower two SFP+ port rows (at the bottom). Copper SFP transceivers are supported only on the bottom two SFP+ rows. The copper SFP transceivers (1000BASE-T) are limited to these rows because they are physically larger than optical SFP transceivers (1000BASE-X). Stacking copper SFP transceivers in all three rows causes internal damage to the line card. Optical SFP transceivers can be stacked and used in all SFP+ ports, **0** through **59**.

You can configure any of the 66 ports **0** through **65** as either uplink or access ports. The ports are enabled by default, and the default configuration adds the ports to the default VLAN.

Port Groups

The six combination ports of QSFP28 and QSFP+ can operate either as six independent 40GbE ports or as two port groups. The first port group is controlled by QSFP28 port **60** and administratively bundled with QSFP+ ports **61** and **62**. The second port group is controlled by QSFP28 port **64** and administratively bundled with QSFP+ ports **63** and **65**. To enable the port group, insert a 100GbE transceiver into the QSFP28 port and configure the port as a 100-Gbps port. Junos OS enables the QSFP28 port at 100-Gbps speed and disables the two QSFP+ ports bundled in the port group. [Figure 71 on page 189](#) shows the location of QSFP28 ports and port groups for the QFX10000-60S-6Q. [Table 65 on page 189](#) shows the available combinations for the ports.

Figure 71: QFX10000-60S-6Q Port Groups

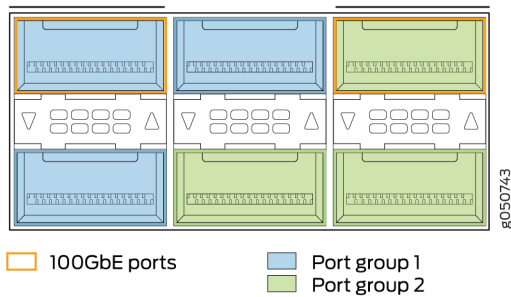


Table 65: QFX10000-60S-6Q Port Mapping

Port Number	4X10GbE	4X10GbE Channelized Port Group	40GbE	100GbE	100GbE Disables
60	✓	✓	✓	✓	61, 62
61	✓		✓	-	-
62	✓		✓	-	-
63	✓	✓	✓	-	-
64	✓		✓	✓	63, 65

Table 65: QFX10000-60S-6Q Port Mapping (Continued)

Port Number	4X10GbE	4X10GbE Channelized Port Group	40GbE	100GbE	100GbE Disables
65	✓		✓	-	-

Channelization of 40GbE Ports

Channelization from a 40GbE port into four independent 10GbE ports is supported on the QSFP28 and QSFP+ ports. Channelization to 50-Gbps or 25-Gbps speed is not supported on the 100GbE QSFP28 port. All ports in the port group are channelized when port **60** or port **64** is channelized. Ports cannot be channelized individually.

To channelize a 40-Gbps port to four independent 10-Gbps ports (or channels), use the `set chassis fpc slot slot-number pic slot slot-number port port-number channel-speed speed` command. For example, to channelize ports **60** through **62** for a line card in slot **6**:

```
[edit chassis fpc 6 pic 1]
user@router# set port 60 speed 10g
```

Review your configuration and issue the `commit` command.

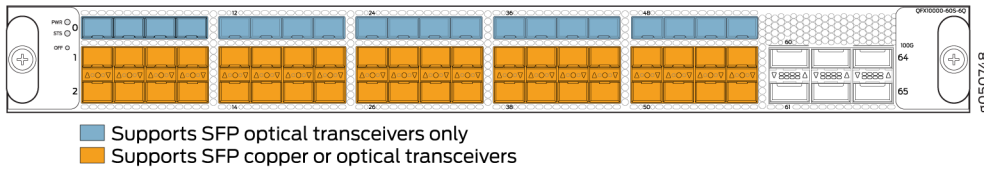
If you want to return the port to the default, delete the `speed` statement from the configuration at the `[chassis fpc 6 pic 1 port port-number]` hierarchy level and commit the configuration. The network port is reset to the default 40GbE interface.

```
[edit chassis fpc 6 pic 1]
user@router# delete port 60 speed 10g
```

Using Copper and Fiber SFP Transceivers

When you configure the 10GbE ports **0** to **59** as 1GbE ports, you can use optical fiber SFP transceivers in any of the ports. However, copper SFP transceivers are restricted to the lower two rows. See [Figure 72 on page 191](#).

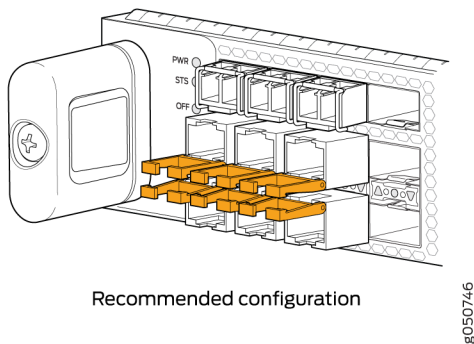
Figure 72: Supported Placement for Copper and Fiber SFP+ Transceivers



CAUTION: Stacking three copper SFP transceivers in a column can cause damage to the line card.

Because 1-Gbps copper SFP transceivers are physically larger than optical SFP transceivers, there is insufficient room for three copper SFP transceivers to be stacked. Use the top row only for optical SFP transceivers. You can stack copper transceivers in the bottom two rows. Ports are arranged belly-to-belly. Stacking three SFP transceivers in a column can damage the line card. For the recommended configuration, see [Figure 73 on page 191](#).

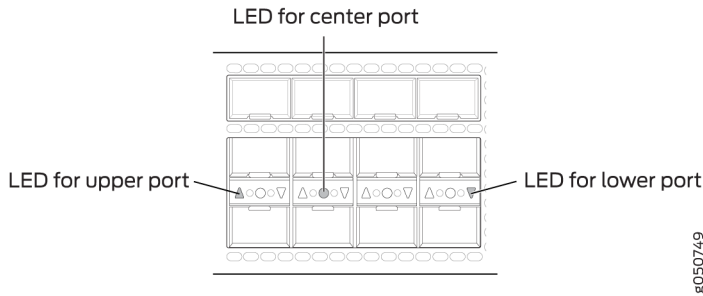
Figure 73: Belly-to-Belly SFP Transceivers



SFP+ Status and Activity LEDs

All status and activity LEDs for the SFP+ ports are located between the second and third rows of SFP+. The up arrow, circle, and down arrow indicate the row of the status. A bicolor LED indicates the status and activity. See [Figure 74 on page 192](#) and [Table 66 on page 192](#).

Figure 74: SFP+ Port Indicators and Status LEDs on a QFX10000-60S-6Q Line Card



- An up arrow indicates the first row.
- A circle indicates the second row.
- A down arrow indicates the third row.

Table 66: Network Port Status and Activity LEDs for SFP+ Ports on a QFX10000-60S-6Q Line Card

Color	State	Description
Unlit	Off	The port is administratively disabled, there is no power, the link is down, or a transceiver is not present.
Green	On steadily	A link is established.
Yellow or amber	Slow blink, or blip	The beacon function is enabled on one or more sub-channels.
	Blinking	The interface has a fault condition.

QSFP+ and QSFP28 Status and Activity LEDs

All QSFP+ and QSFP28 ports have an up or down indicator for each port and four bicolored LEDs that show port status and link activity based on whether or not the port is configured for channelization. See [Table 67 on page 193](#).

Figure 75: LED Indicators on QSFP+ and QSFP28 Ports on a QFX10000-60S-6Q Line Card

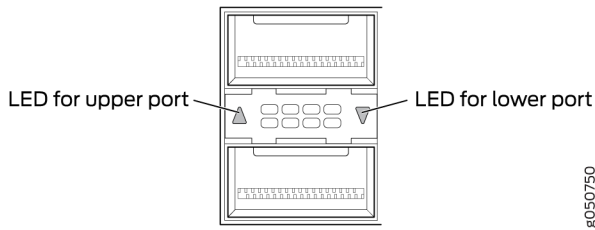


Table 67: QSFP+ and QSFP28 Network Port Status and Activity LEDs

Color	State	Description
Unlit	Off	The port is administratively disabled, there is no power, the link is down, or a transceiver is not present. All sub-channels are disabled.
Green	On steadily	A link is established. When channelized, all sub-channels are up. When not channelized, it indicates no activity.
Yellow or amber	On steadily	At least one channel link is up, but not all channels are up.
	Slow blink, or blip	The beacon function is enabled on one or more sub-channels.
	Blinking	One or more sub-channels has a fault condition.

PTX10008 Line Card LEDs

All PTX10008 line cards have two bicolored LEDs. The PTX10K-LC1201-36CD LEDs are green and red, while the other line card LEDs are green and amber. See [Figure 76 on page 194](#).

Figure 76: Line Card LEDs

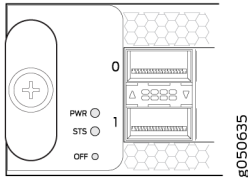


Table 68 on page 194 describes the functions of the line card LEDs other than PTX10K-LC1201-36CD. See Table 69 on page 195 for PTX10K-LC1201-36CD behavior.

Table 68: Line Card LEDs

Label	Color	State	Description
PWR	Unlit	Off	The line card is not receiving power.
	Green	On steadily	The line card is receiving power.
	Yellow	Blinking	The line card has a power error, such as insufficient power.
STS	Unlit	Off	The line card is offline.
	Green	On steadily	The line card is online and functioning normally.
	Green	Blinking	The beacon feature is enabled on the line card.
	Yellow	On steadily	The line card is booting.
	Yellow	Blinking	The line card is detecting an error.

Table 69: PTX10K-LC1201-36CD LEDs

Label	Color	Normal State	Beacon Active State	Description
PWR	Green	On steadily	On steadily	The line card is receiving power.
	Red	On steadily	On steadily	The line card is detecting an error.
	Unlit	Off	Off	The line card is not receiving power.
STS	Green	On steadily	Blinking	The line card is online.
	Green	Blinking	Blinking	The line card is booting.
	Red	On steadily	Blinking	The line card is detecting an error.

RELATED DOCUMENTATION

[PTX10008 Field-Replaceable Units | 49](#)

[Install a PTX10008 Line Card | 434](#)

3

CHAPTER

Site Planning, Preparation, and Specifications

[PTX10008 Site Preparation Overview | 197](#)

[PTX10008 Power Planning for JNP10008-SF Switch Fabric | 207](#)

[PTX10008 Power Planning for JNP10008-SF3 Switch Fabric | 244](#)

[PTX10008 Grounding Cable and Lug Specifications | 267](#)

[PTX10008 Transceiver and Cable Specifications | 268](#)

[PTX10008 Console and Management Cable Specifications and Pinouts | 275](#)

PTX10008 Site Preparation Overview

IN THIS SECTION

- [PTX10008 Site Preparation Checklist | 197](#)
- [PTX10008 Environmental Requirements and Specifications | 199](#)
- [PTX10008 General Site Guidelines | 200](#)
- [PTX10008 Site Electrical Wiring Guidelines | 201](#)
- [PTX10008 Rack Requirements | 202](#)
- [PTX10008 Clearance Requirements for Airflow and Hardware Maintenance | 205](#)

The following sections describe the guidelines, the specifications, and the requirements to prepare the site for installing a PTX10008 router.

PTX10008 Site Preparation Checklist

The checklist in [Table 70 on page 197](#) summarizes the tasks you need to perform when preparing a site for a PTX10008 installation.

Table 70: Site Preparation Checklist

✓	Item or Task	For More Information
Environment		
□	Verify that environmental factors such as temperature and humidity do not exceed router tolerances.	"PTX10008 Environmental Requirements and Specifications" on page 199
Power		
□	Measure the distance between external power sources and the router installation site.	

Table 70: Site Preparation Checklist (*Continued*)

✓	Item or Task	For More Information
	<input type="checkbox"/> Calculate the power consumption and requirements.	"PTX10008 Power Planning for JNP10008-SF Switch Fabric" on page 207 or "PTX10008 Power Planning for JNP10008-SF3 Switch Fabric" on page 244
Rack		
	<input type="checkbox"/> Verify that your rack meets the minimum requirements for the installation of the router.	"PTX10008 Rack Requirements" on page 202
	<input type="checkbox"/> Plan rack location, including required space clearances.	"PTX10008 Clearance Requirements for Airflow and Hardware Maintenance" on page 205
	<input type="checkbox"/> Secure the rack to the floor and building structure.	
Cables		
	<input type="checkbox"/> Acquire cables and connectors: <ul style="list-style-type: none"> • Determine the number of cables needed based on your planned configuration. • Review the maximum distance allowed for each cable. Choose the length of cable based on the distance between the hardware components being connected. 	The list of supported transceivers for the PTX10008 line cards is located at https://apps.juniper.net/hct/product/#prd=PTX10008 .
	<input type="checkbox"/> Plan the cable routing and management.	
	<input type="checkbox"/> Hardware Upgrades	Order upgrade kits or individual components. See "PTX10008 Configurations and Upgrade Options" on page 31 .

PTX10008 Environmental Requirements and Specifications

The PTX10008 router must be installed in a four-post rack. It must be housed in a dry, clean, well-ventilated, and temperature-controlled environment.

Follow these environmental guidelines:

- The site must be as dust-free as possible, because dust can clog air intake vents and filters, reducing the efficiency of the router cooling system.
- Maintain ambient airflow for normal router operation. If the airflow is blocked or restricted, or if the intake air is too warm, the router might overheat, leading to the router temperature monitor shutting down the device to protect the hardware components.

[Table 71 on page 199](#) provides the required environmental conditions for normal router operation.

Table 71: PTX10008 Environmental Tolerances

Description	Tolerance
Altitude	No performance degradation up to 6562 feet (2000 meters).
Relative humidity	<p>Normal operation ensured in relative humidity range of 5% through 90%, noncondensing.</p> <ul style="list-style-type: none"> • Short-term operation ensured in relative humidity range of 5% through 93%, noncondensing. <p>NOTE: As defined in NEBS GR-63-CORE, Issue 3, short-term events can be up to 96 hours in duration but not more than 15 days per year.</p>

Table 71: PTX10008 Environmental Tolerances (*Continued*)

Description	Tolerance
Temperature	<ul style="list-style-type: none"> • Normal operation ensured in temperature range of 32° F through 104° F (0° C through 40° C). <p>NOTE: The maximum supported temperature for normal operation must be lower by 3° C when the air filter is new and lower by 6° C when the air filter is at the end of its life.</p> <ul style="list-style-type: none"> • Nonoperating storage temperature in shipping container: –40° F through 158° F (–40° C through 70° C). • Short-term operation: 23° F to 155° F (–5° C to +50° C). <p>NOTE: As defined in NEBS GR-63-CORE, Issue 3, short-term events can be up to 96 hours in duration but not more than 15 days per year.</p>
Seismic	Designed to comply with Zone 4 earthquake requirements according to NEBS GR-63-CORE, Issue 3.

NOTE: Install PTX10008 routers only in restricted-access areas, such as dedicated equipment rooms and equipment closets, in accordance with Articles 110-16, 110-17, and 110-18 of the National Electrical Code, ANSI/NFPA 70.

PTX10008 General Site Guidelines

Efficient device operation requires proper site planning and maintenance and proper layout of the equipment, rack or cabinet (if used), and wiring closet.

To plan and create an acceptable operating environment for your device and prevent environmentally caused equipment failures:

- Keep the area around the chassis free from dust and conductive material, such as metal flakes.
- Follow prescribed airflow guidelines to ensure that the cooling system functions properly and that exhaust from other equipment does not blow into the intake vents of the device.

- Follow the prescribed electrostatic discharge (ESD) prevention procedures to prevent damaging the equipment. Static discharge can cause components to fail completely or intermittently over time.
- Install the device in a secure area, so that only authorized personnel can access the device.

SEE ALSO

[Prevention of Electrostatic Discharge Damage | 509](#)

PTX10008 Environmental Requirements and Specifications

PTX10008 Site Electrical Wiring Guidelines

Table 72 on page 201 describes the factors you must consider while planning the electrical wiring at your site.



CAUTION: It is particularly important to provide a properly grounded and shielded environment and to use electrical surge-suppression devices.

Table 72: Site Electrical Wiring Guidelines

Site Wiring Factor	Guideline
Signaling limitations	<p>To ensure that signaling functions optimally:</p> <ul style="list-style-type: none"> • Install wires correctly. Improperly installed wires can emit radio interference. • Do not exceed the recommended distances or pass wires between buildings. The potential for damage from lightning strikes increases if wires exceed recommended distances or if wires pass between buildings. • Shield all conductors. The electromagnetic pulse (EMP) caused by lightning can damage unshielded conductors and destroy electronic devices.

Table 72: Site Electrical Wiring Guidelines (*Continued*)

Site Wiring Factor	Guideline
Radio frequency interference (RFI)	<p>To reduce or eliminate the emission of RFI from your site wiring:</p> <ul style="list-style-type: none"> • Use twisted-pair cable with a good distribution of grounding conductors. • Use a high-quality twisted-pair cable with one ground conductor for each data signal when applicable, if you must exceed the recommended distances.
Electromagnetic compatibility (EMC)	<p>Provide a properly grounded and shielded environment and use electrical surge-suppression devices.</p> <p>Strong sources of electromagnetic interference (EMI) can cause the following damage:</p> <ul style="list-style-type: none"> • Destruction of the signal drivers and receivers in the device. • Electrical hazards as a result of power surges conducted over the lines into the equipment. <p>TIP: If your site is susceptible to problems with EMC, particularly from lightning or radio transmitters, you might want to seek expert advice.</p>



WARNING: The intrabuilding port(s) of the equipment or subassembly is suitable for connection to intrabuilding or unexposed wiring or cabling only. The intrabuilding port(s) of the equipment or subassembly **MUST NOT** be metallically connected to interfaces that connect to the OSP or its wiring. These interfaces are designed for use as intrabuilding interfaces only (Type 2 or Type 4 ports as described in GR-1089-CORE), and require isolation from the exposed OSP cabling. The addition of primary protectors is not sufficient protection to connect these interfaces metallically to OSP wiring.

PTX10008 Rack Requirements

The PTX10008 router chassis are designed to be installed in four-post racks.

Rack requirements consist of:

- Rack type

- Rack mount kit hole spacing
- Rack size and strength
- Rack connection to the building structure

Table 73 on page 203 provides the rack requirements and specifications for the PTX10008 router.

Table 73: Rack Requirements for the PTX10008

Rack Requirement	Guidelines
Rack type: four-post	<p>Use a four-post rack that provides bracket holes or hole patterns spaced at 1 U (1.75 in. or 4.45 cm) increments and that meets the size and strength requirements to support the weight.</p> <p>A U is the standard rack unit defined in <i>Cabinets, Racks, Panels, and Associated Equipment</i> (document number EIA-310-D) published by the Electronics Industry Association.</p> <p>You can stack three PTX10008 routers at the bottom of the four-post rack if:</p> <ul style="list-style-type: none"> • The rack is 42 U or greater. • The rack meets the strength requirements to support the weight. • The facility can provide adequate power and cooling.
Rack mount kit hole spacing	The holes in the rack mount kit are spaced at 1 U (1.75 in. or 4.45 cm), so that the router can be mounted in any rack that provides holes spaced at that distance.

Table 73: Rack Requirements for the PTX10008 (Continued)

Rack Requirement	Guidelines
Rack size and strength	<ul style="list-style-type: none"> • Ensure that the rack complies with the standards for a 19-in. wide rack as defined in <i>Cabinets, Racks, Panels, and Associated Equipment</i> (document number EIA-310-D) published by the Electronics Industry Association. • Use one of the standard rack lengths as defined in the four-part <i>Equipment Engineering (EE); European telecommunications standard for equipment practice</i> (document numbers ETS 300 119-1 through 119-4) published by the European Telecommunications Standards Institute (http://www.etsi.org). <ul style="list-style-type: none"> • 23.62 in. (600 mm) • 30.0 in. (762 mm) • 31.5 in. (800 mm) • Ensure that the rack rails are spaced widely enough to accommodate the router chassis' external dimensions. The outer edges of the flange extend the chassis width to 19 in. (48.26 cm). • Ensure that the rack is strong enough to support the weight of the router and cabling. • Ensure that the spacing of rails and adjacent racks allows for proper clearance around the router and rack. See "PTX10008 Clearance Requirements for Airflow and Hardware Maintenance" on page 205.
Rack connection to building structure	<ul style="list-style-type: none"> • Secure the rack to the building structure. • If earthquakes are a possibility in your geographical area, secure the rack to the floor. • Secure the rack to the ceiling as well as wall or floor for maximum stability.

PTX10008 Clearance Requirements for Airflow and Hardware Maintenance

When planning the site for a PTX10008 router installation, you must allow sufficient clearance around the installed chassis for cooling and maintenance. See [Figure 77 on page 205](#) and [Figure 78 on page 206](#) for a top view of clearance for the PTX10008.

Figure 77: Clearance Requirements for Airflow and Hardware Maintenance for a PTX10008 Chassis with JNP10008-FAN

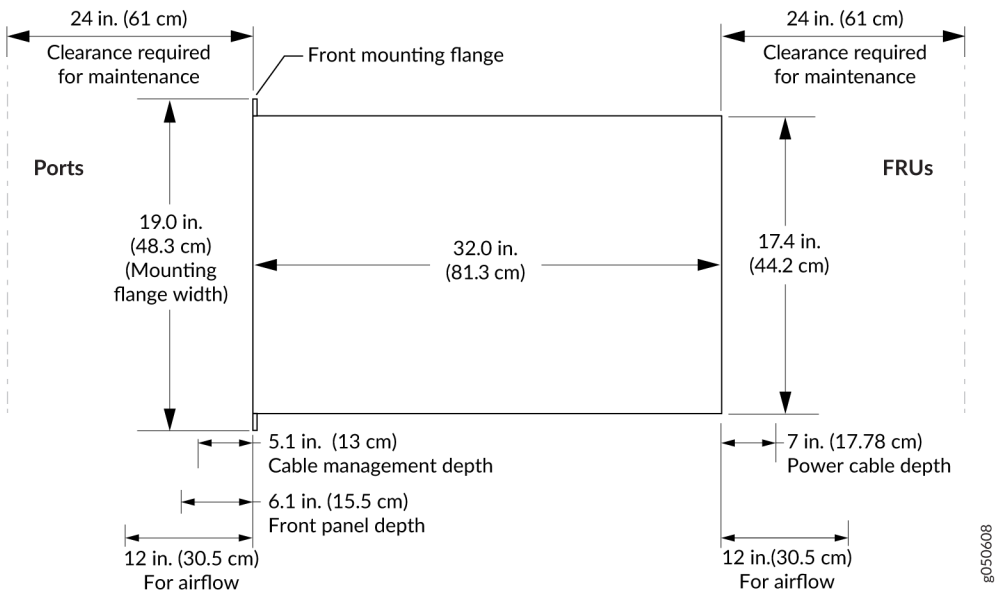
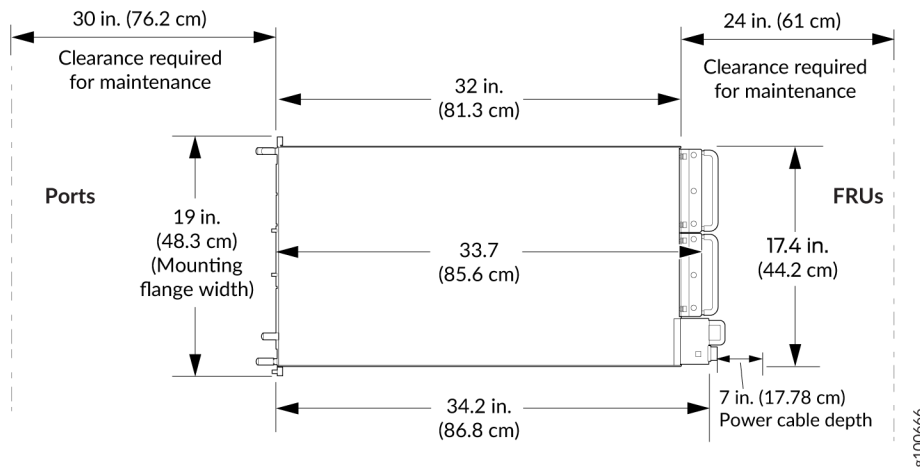


Figure 78: Clearance Requirements for Airflow and Hardware Maintenance for a PTX10008 with JNP10008-FAN2



NOTE: For JNP10K-PWR-AC3 power supply, the overall depth is 36 in. (91.44 cm) instead of 34.2 in. and the power cable depth is 6 in. (15.24 cm) instead of 7 in.

Follow these guidelines:

- For the cooling system to function properly, the airflow around the chassis must be unrestricted. See ["PTX10008 Cooling System and Airflow" on page 58](#) for more information about the airflow through the chassis.
- If you are mounting a PTX10008 in a rack with other equipment, ensure that the exhaust from other equipment does not blow into the intake vents of the chassis.
- Leave at least 24 in. (61 cm) both in front of and behind the PTX10008 for service personnel to remove and install hardware components. To be NEBS GR-63 compliant, allow at least 30 in. (76.2 cm) in front of the rack and 24 in. (61 cm) behind the rack.

SEE ALSO

PTX10008 Rack Requirements

[General Safety Guidelines and Warnings | 484](#)

[Rack-Mounting and Cabinet-Mounting Warnings | 492](#)

RELATED DOCUMENTATION

General Safety Guidelines and Warnings

Rack-Mounting and Cabinet-Mounting Warnings

[PTX10008 Clearance Requirements for Airflow and Hardware Maintenance | 205](#)

[Mount the PTX10008 by Using the JNP10004-RMK-4POST Rack Mount Kit | 291](#)

[Mount the PTX10008 by Using the EX-MOD-RMK-4POST Rack Mount Kit | 298](#)

PTX10008 Power Planning for JNP10008-SF Switch Fabric

IN THIS SECTION

- [Power Requirements for PTX10008 Components in a JNP10008-SF Fabric | 208](#)
- [Calculate Power Requirements for a PTX10008 | 209](#)
- [JNP10K-PWR-AC Power Specifications | 219](#)
- [JNP10K-PWR-AC2 Power Specifications | 220](#)
- [JNP10K-PWR-AC3 Power Specifications | 221](#)
- [PTX10008 Power Cables Specifications | 222](#)
- [JNP10K-PWR-AC3 Power Cable Specifications | 232](#)
- [JNP10K-PWR-DC Power Specifications | 242](#)
- [JNP10K-PWR-DC2 Power Specifications | 243](#)

Use this information to calculate the power consumption for the PTX10008 in a JNP10008-SF switch fabric and plan your configuration's power requirements.

Power Requirements for PTX10008 Components in a JNP10008-SF Fabric

Table 74 on page 208 lists the power requirements for the PTX10008 router running the JNP10008-SF switch fabric under typical voltage conditions and optics.

Table 74: Power Consumption JNP10008-SF Fabric Systems

Component	Description	At 25° C	At 55° C
JNP10008-SF	PTX10008 Switch Interface Board	170 W	235 W
JNP10008-FAN	PTX10008 fan tray	225 W	475 W
JNP10008-FAN2	PTX10008 enhanced fan tray	600 W	1280 W at maximum fan speed
JNP10K-RE0	PTX10008 standard Routing Control Board	50 W	100 W
JNP10K-RE1 or JNP10K-RE1-LT	PTX10008 enhanced Routing Control Board	150 W	175 W
PTX10K-LC1101	PTX10008 30-port QSFP28 line card	890 W	1750 W
PTX10K-LC1102	PTX10008 36-port QSFP+ line card	520 W	675 W
PTX10K-LC1104	PTX10008 coherent DWDM line card	900 W	1050 W
PTX10K-LC1105	PTX10008 30-port MACsec QSFP28 line card	950 W	1250 W
QFX10000-60S-60 Q	QFX10000 60-port SFP+ and 6-port QSFP+ line card	365 W	465 W



CAUTION: To ensure adequate power and to avoid raising a power alarm, we recommend that you maintain $n+1$ power supplies in your router at all times. Replace failed power supplies immediately to prevent unexpected failures.

If a new line card is installed in an operational router, power management does not power on the line card if the increased power demand exceeds the total available power, including redundant power. If redundant power is used to power on the line card, a minor alarm is raised, which becomes a major alarm in five minutes if the condition is not corrected.

You can view the total power provided to the chassis, the power required to operate the chassis and the components installed in it, and the balance power available in the chassis by using the [show chassis power detail](#) command.

Calculate Power Requirements for a PTX10008

IN THIS SECTION

- [Calculate the Power Consumption of Your PTX10008 Configuration | 210](#)
- [Calculate the Number of Power Supplies Required for Your PTX10008 Configuration | 212](#)

Use the information in this topic to calculate power requirements of your PTX10008 configuration and the number of power supplies required for different PTX10008 router configurations.



CAUTION: To ensure adequate power and to avoid raising a power alarm, we recommend that you maintain $n+1$ power supplies in JNP10008-SF configurations at all times. Replace failed power supplies immediately to prevent unexpected failures.

If a new line card is installed in an operational router, power management does not power on the line card if the increased power demand exceeds the total available power, including redundant power. If redundant power is used to power on the line card, a minor alarm is raised, which becomes a major alarm in five minutes if the condition is not corrected.

NOTE: The calculations in this topic represent the maximum power requirements that you need to budget for your PTX10008 router configuration. The actual power consumption of your router will be less than the calculated results shown here and will vary based on the hardware and software configuration of your router, the amount of traffic passing through the line cards, and environmental variables such as room temperature.

Before you begin these calculations:

- Ensure you understand the different router configurations. See "[PTX10008 Configurations and Upgrade Options](#)" on page 31.
- Ensure that you know the power requirements of different router components. See "[Power Requirements for PTX10008 Components in a JNP10008-SF Fabric](#)" on page 208.

This topic describes these tasks:

Calculate the Power Consumption of Your PTX10008 Configuration

Use the following procedure to determine the maximum power you need to supply to the router. To calculate maximum system power consumption, you first determine the combined maximum internal power requirements of all the router components and then divide this result by the power supply output power.

To calculate maximum system power consumption:

1. Determine the maximum power consumption of the base chassis components (that is, the components other than the line cards). Use Table 2 if your router is configured as either the standard base or redundant configuration.

Table 75: Chassis Power Consumption for Standard Configurations

Chassis Component	Base Configuration	Premium Configuration
JNP10008-FAN	950 W	950 W
JNP10008-FAN2 *	—	—
JNP10K-RE0, or JNP10K-RE1	175 W	350 W
JNP10008-SF	1175 W (5 SIBs)	1410 W (6 SIBs)

Table 75: Chassis Power Consumption for Standard Configurations (Continued)

Chassis Component	Base Configuration	Premium Configuration
Total	2300 W	2710 W

* JNP10008-FAN2 is an optional upgrade that replaces JNP10008-FAN. Use 2,560 W for JNP10008-FAN2 configurations. JNP10008-FAN2 systems require JNP10K-PWR-AC2 or JNP10K-PWR-DC2 power supplies.

2. Calculate the maximum internal power consumption of the entire router by adding in the power requirements of each line card. See Table 3 for a chart of the power needed for line cards.

Table 76: Line Card Power Consumption

Line Cards	PTX10K-LC1101	PTX10K-LC1102	PTX10K-LC1104	PTX10K-LC1105	QFX10000-60S-6Q
1	1150 W	675 W	1050 W	1250 W	455 W
2	2300 W	1350 W	2100 W	2500 W	910 W
3	3450 W	2025 W	3150 W	3750 W	1365 W
4	4600 W	2700 W	4200 W	5000 W	1820 W
5	5750 W	3375 W	—	6250 W	2275 W
6	6900 W	4050 W	—	7500 W	2730 W
7	8050 W	4725 W	—	8750 W	3185 W
8	9200 W	5400 W	—	10,000 W	3640 W

NOTE: * The PTX10K-LC1201-36CD power numbers do not include the power draw of optical transceivers. See the [Hardware Compatibility Tool](#) for further information.

NOTE: The PTX10K-LC1104 line card is designed to comply with NEBS regulations on the PTX10008 Packet Transport Router when these routers are used in typical configurations. In a typical configuration, a PTX10008 router supports up to eight line cards, with up to four PTX10K-LC1104 line cards in any of the eight slots.

For example, for a PTX10008 with five PTX10K-LC1102 line cards and three PTX10K-LC1101 line cards, the maximum power consumption is:

= 5 (power consumed by PTX10K-LC1102 in watts) + 3 (power consumed by PTX10K-LC1101 line cards in watts)

= 5 (675 W) + 3 (1150 W)

= (3375 W + 3450 W)

= 6825 W

3. Add the power consumption from Step 1 and the total line card consumption from Step 2.

To continue from the previous example, add the wattage from five PTX10K-LC1102 and three PTX10K-LC1101 cards to a premium configuration.

(6825 W) + (2710 W)

= 9535 W required

Calculate the Number of Power Supplies Required for Your PTX10008 Configuration

Use this procedure to calculate the number of power supplies required by your router configuration. The minimum power configuration for PTX10008 routers is three power supplies. However, using the calculated minimum power configuration does not prevent the system from raising a power alarm. If you are running the router in a JNP10008-SF switch fabric configuration, you must configure your router for $n+1$ power supplies to ensure you do not log power alarms.

To calculate the number of power supplies required for your minimum router configuration:

1. Determine the power available from the power supplies. [Table 77 on page 213](#) shows the power available for installed power supplies.

NOTE: DC systems are supported only in the redundant configuration.

Table 77: Total Power Available

Power Supply Module Models	With Three Power Supplies	With Four Power Supplies	With Five Power Supplies
JNP10K-PWR-AC	8,100 W	10,800 W	13,500 W
JNP10K-PWR-AC2 dual feed, high power (30-A) setting	16,500 W	22,000 W	27,500 W
JNP10K-PWR-AC2 single feed, high power (30-A) setting	15,000 W	20,000 W	25,000 W
JNP10K-PWR-AC2, dual feed, low power (20-A) setting	9,000 W	12,000 W	15,000 W
JNP10K-PWR-AC2, single feed, low power (20-A) setting	8,100 W	10,800 W	13,500 W
JNP10K-PWR-AC3, single active feed, (15-A) setting	7,500 W	10,000 W	12,500 W
JNP10K-PWR-AC3, two active feeds, (15-A) setting	15,000 W	20,000 W	25,000 W
JNP10K-PWR-AC3, three active feeds, (15-A) setting	22,500 W	30,000 W	37,500 W
JNP10K-PWR-AC3, four active feeds, (15-A) setting	23,400 W	31,200 W	39,000 W

Table 77: Total Power Available (Continued)

Power Supply Module Models	With Three Power Supplies	With Four Power Supplies	With Five Power Supplies
JNP10K-PWR-AC3, single active feed, (20-A) setting	9,000 W	12,000 W	15,000 W
JNP10K-PWR-AC3, two active feeds, (20-A) setting; (either A0 and A1 or B0 and B1)	18,000 W	24,000 W	30,000 W
JNP10K-PWR-AC3, three or four active feeds, (20-A) setting	23,400 W	31,200 W	39,000 W
JNP10K-PWR-DC	7,500 W	10,000 W	12,500 W
JNP10K-PWR-DC2 dual feed, high power (80-A) setting	16,500 W	22,000 W	27,500 W
JNP10K-PWR-DC2 dual feed, low power (60-A) setting	13,200 W	17,600 W	22,000 W
JNP10K-PWR-DC2 single feed, high power (80-A) setting	8,250 W	11,000 W	13,750 W
JNP10K-PWR-DC2 single feed, low power (60-A) setting	6,600 W	8,800 W	11,000 W

NOTE: The JNP10K-PWR-AC2 power supply has a set of DIP switches on the faceplate that allows you to configure the power supply for either high power (30 A) or low power (20 A)

input mode. If any JNP10K-PWR-AC2 power supply is set to 20 A, then the power budget for all power supplies installed in the system becomes 20 A, regardless of whether other power supplies are set at 30 A. This design helps prevent overloading of the power supply that is set to 20 A. See [Table 78 on page 215](#) for details about setting the DIP switches and available power.

Table 78: Power Input and Output Voltages for JNP10K-PWR-AC2 Power Supplies

INP0 (Switch 1)	INP1 (Switch 2)	H/L (High Input 30 A/ Low Input 20A)	Output Power
On	On	On (30 A)	5500 W
On	On	Off (20 A)	3000 W
On	Off	On (30 A)	5000 W
Off	On	On (30 A)	5000 W
On	Off	Off (20 A)	2700 W
Off	On	Off (20 A)	2700 W

NOTE: The JNP10K-PWR-AC3 power supply has a set of five DIP switches on the faceplate that allows you to configure the power supply for either high power (20 A) or low power (15 A) input mode. If any JNP10K-PWR-AC3 power supply is set to 15 A, then the power budget for all power supplies installed in the system becomes 15 A, regardless of whether other power supplies are set at 20 A. This design helps prevent overloading of the power supply that is set to 15 A.

Table 79: Power Input and Output Voltages for JNP10K-PWR-AC3 Power Supplies

INP-A0 (Switch 0)	INP-A1 (Switch 1)	INP-B0 (Switch 2)	INP-B1 (Switch 3)	Switch 4 (High Input 20 A/ Low Input 15 A)	Output Power
15-A					
Off	Off	Off	On	Off (15 A)	2500 W
Off	Off	On	Off	Off (15 A)	2500 W
Off	Off	On	On	Off (15 A)	5000 W
Off	On	Off	Off	Off (15 A)	2500 W
Off	On	Off	On	Off (15 A)	5000 W
Off	On	On	On	Off (15 A)	7500 W
Off	On	On	Off	Off (15 A)	5000 W
On	Off	Off	Off	Off (15 A)	2500 W
On	Off	Off	On	Off (15 A)	5000 W
On	Off	On	Off	Off (15 A)	5000 W
On	Off	On	On	Off (15 A)	7500 W
On	On	Off	Off	Off (15 A)	5000 W
On	On	Off	On	Off (15 A)	7500 W
On	On	On	Off	Off (15 A)	7500 W

Table 79: Power Input and Output Voltages for JNP10K-PWR-AC3 Power Supplies (Continued)

INP-A0 (Switch 0)	INP-A1 (Switch 1)	INP-B0 (Switch 2)	INP-B1 (Switch 3)	Switch 4 (High Input 20 A/ Low Input 15 A)	Output Power
On	On	On	On	Off (15 A)	7800 W
20-A					
Off	Off	Off	On	On (20 A)	3000 W
Off	Off	On	Off	On (20 A)	3000 W
Off	Off	On	On	On (20 A)	6000 W
Off	On	Off	Off	On (20 A)	3000 W
Off	On	Off	On	On (20 A)	6000 W
Off	On	On	Off	On (20 A)	6000 W
Off	On	On	On	On (20 A)	7800 W
On	Off	Off	Off	On (20 A)	3000 W
On	Off	Off	On	On (20 A)	6000 W
On	Off	On	Off	On (20 A)	6000 W
On	Off	On	On	On (20 A)	7800 W
On	On	Off	Off	On (20 A)	6000 W
On	On	Off	On	On (20 A)	7800 W

Table 79: Power Input and Output Voltages for JNP10K-PWR-AC3 Power Supplies (Continued)

INP-A0 (Switch 0)	INP-A1 (Switch 1)	INP-B0 (Switch 2)	INP-B1 (Switch 3)	Switch 4 (High Input 20 A/ Low Input 15 A)	Output Power
On	On	On	Off	On (20 A)	7800 W
On	On	On	On	On (20 A)	7800 W

2. Determine the total power required for your configuration with line cards installed. The total power available to the chassis is calculated by dividing the wattage needed by the power rating, and then rounding up.

In the previous examples, we calculated that a premium PTX10008 AC system would require 9535 W with five PTX10K-LC1102 and three PTX10K-LC1101 line cards. In this example, we calculate the total power available for the 2700 W JNP10K-PWR-AC power supplies:

$$= (9535 \text{ W}) / (2700 \text{ W})$$

$$= 3.5$$

Round up the result to 4 AC power supplies to determine the minimum power level.



CAUTION: The minimum power level does not prevent the system from raising a power alarm. Add an additional power supply for redundancy ($n+1$) to ensure you have covered the maximum power budget for your specific configuration.

In our example, a basic configuration (3 power supplies, standard) would require two additional power supplies, one for the minimum power level and second as the redundant power supply. In a redundant AC system (6 power supplies, standard), the system would have sufficient power supplies for both minimum and $n+1$ redundancy.

3. Calculate how much power the power supplies need. To determine the power required, multiply the number of power supplies by the power supply wattage and divide by the efficiency of the power supply. The efficiency rate accounts for the loss of energy within the power supply and is 89 percent for PTX10008 power supplies.

For example, if you have an AC system with four power supplies:

$$= 4 (2700 \text{ W}) / (\text{efficiency rating})$$

$$= (10800 \text{ W}) / (0.89)$$

$$= 12135 \text{ W}$$

JNP10K-PWR-AC Power Specifications

PTX10008 and PTX10016 redundant-configuration routers can use either AC or DC power supplies; base-configuration routers are AC only. You can run the JNP10K-PWR-AC power supply only in routers in which you have installed the JNP10008-SF or JNP10016-SF switch fabric.

[Table 80 on page 219](#) lists the power specifications for the AC power supply (JNP10K-PWR-AC) used in a PTX10008 or PTX10016 chassis.

Table 80: Power Specifications for a JNP10K-PWR-AC Power Supply

Item	Specification
AC input voltage	Operating range: 200–240 VAC
AC input line frequency	50–60 Hz
AC input current rating	16 A
AC output power	2700 W



CAUTION: Use a 2-pole circuit breaker rated at 25 A in the building installation and the system, or as per local electrical code.

[Table 81 on page 219](#) shows the physical specifications for an AC power supply.

Table 81: Physical Specifications for a JNP10K-PWR-AC Power Supply

Specification	Value
Height	3.4 in. (8.64 cm)

Table 81: Physical Specifications for a JNP10K-PWR-AC Power Supply (Continued)

Specification	Value
Width	3.6 in. (9.14 cm)
Depth	14.4 in. (36.58 cm)
Weight	6.8 lb (3.08 kg)

JNP10K-PWR-AC2 Power Specifications

The JNP10K-PWR-AC2 power supply supports AC, HVAC, and HVDC. You can run JNP10K-PWR-AC2 power supplies in either a JNP10008-SF or a JNP10008-SF3 system. If you are upgrading a JNP10008-SF system to use JNP10K-PWR-AC2 power supplies, also upgrade your fans and fan tray controllers to ensure the proper airflow. JNP10K-PWR-AC2 power supplies require JNP10008-FAN2 and JNP10008-FTC2 cooling systems.

[Table 82 on page 220](#) lists the power specifications for the AC power supply (JNP10K-PWR-AC2) used in a PTX10008 or PTX10016 chassis.

Table 82: Power Specifications for a JNP10K-PWR-AC2 Power Supply

Item	Specifications
AC input voltage	180–305 VAC
DC input voltage	190–410 VDC
Input current rating	28.5 A
DC output power	5500 W with dual feed and 5000 W with single feed

[Table 83 on page 221](#) shows the physical specifications for a JNP10K-PWR-AC2 power supply.

Table 83: Physical Specifications for a JNP10K-PWR-AC2 Power Supply

Specification	Value
Height	3.4 in. (8.64 cm)
Width	3.6 in. (9.14 cm)
Depth	16.6 in. (42.16 cm)
Weight	11.4 lb (5.17 kg)

JNP10K-PWR-AC3 Power Specifications

The JNP10K-PWR-AC3 power supply supports AC.

No Link Title lists the power specifications for the AC power supply (JNP10K-PWR-AC3) used in a PTX10004 chassis.

Table 84: Power Specifications for a JNP10K-PWR-AC3 Power Supply

Specification	Value
AC input voltage	180–264 VAC
Input current rating	16 A
DC output power	12.3 V

No Link Title shows the physical specifications for a JNP10K-PWR-AC3 power supply.

Table 85: Physical Specifications for a JNP10K-PWR-AC3 Power Supply

Specification	Value
Height	3.386 in. (8.60 cm)
Width	3.584 in. (9.10 cm)
Depth	17.15 (43.57 cm)
Weight	12.8 lbs (5.8 kg)

PTX10008 Power Cables Specifications

IN THIS SECTION

- [JNP10K-PWR-AC Power Cable Specifications | 223](#)
- [JNP10K-PWR-AC2 Power Cable Specifications | 226](#)
- [JNP10K-PWR-AC2 Power Cable Specifications for 30-A Input | 229](#)

Most sites distribute power through a main conduit that leads to frame-mounted power distribution panels, one of which can be located at the top of the rack that houses the router. An AC power cord connects each power supply to the power distribution panel.

NOTE: In North America, AC power cords must not exceed 15 feet (approximately 4.5 meters) in length, to comply with National Electrical Code (NEC) Sections 400-8 (NFPA 75, 5-2.2) and 210-52 and Canadian Electrical Code (CEC) Section 4-010(3). The cords shipped with the router to North America and Canada are in compliance.

PTX10008 AC, high-voltage alternating current (HVAC), and high-voltage direct current (HVDC) power supplies have specific cord requirements. Use the following sections to determine the cable requirements based on the model of your power supply and any mode settings:

- For JNP10K-PWR-AC, see ["JNP10K-PWR-AC Power Cable Specifications" on page 223](#)
- For JNP10K-PWR-AC2 with 20-A input, see ["JNP10K-PWR-AC2 Power Cable Specifications" on page 226](#)
- For JNP10K-PWR-AC2 with 30-A input, see ["JNP10K-PWR-AC2 Power Cable Specifications for 30-A Input" on page 229](#)

JNP10K-PWR-AC Power Cable Specifications

Each JNP10K-PWR-AC power supply has two independent 16 A rated AC inlets on the faceplate.

Each detachable AC power cord is 8 feet (approximately 2.5 meters) long. The coupler end of the appliancecord inserts into the AC appliance inlet on the faceplate of the AC power supply. The coupler type is C19 as described by the International Electrotechnical Commission (IEC) standard 60320. The plug end of the power cord fits into the power source outlet that is standard for your geographical location.

[Table 86 on page 223](#) lists the AC power cord specifications for JNP10K-PWR-AC for various countries and regions.

Table 86: AC Power Cord Specifications for JNP10K-PWR-AC Power Supplies

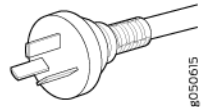
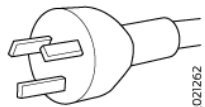
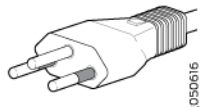
Country/Region	Electrical Specifications	Plug Standards	Juniper Model Number	Graphic
Argentina	250 VAC, 16 A, 50 Hz	IRAM Type RA/3/20	CBL-EX-PWR-C19-AR	
Australia	250 VAC, 15 A, 50 Hz	AS/NZS 3112 Type SAA/3/15	CBL-EX-PWR-C19-AU	
Brazil	250 VAC, 16 A, 50 Hz	NBR 14136: 2002 Type BR/3/20	CBL-EX-PWR-C19-BR	

Table 86: AC Power Cord Specifications for JNP10K-PWR-AC Power Supplies (Continued)

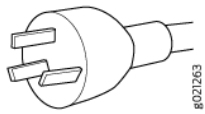
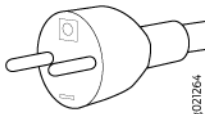
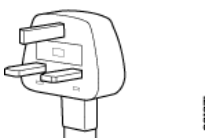
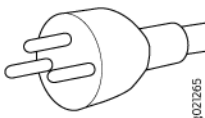
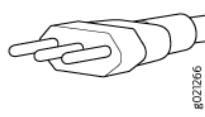
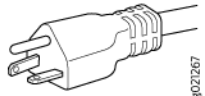
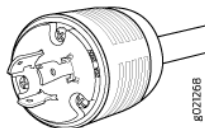
Country/Region	Electrical Specifications	Plug Standards	Juniper Model Number	Graphic
China	250 VAC, 16 A, 50 Hz	GB 1002 Type PRC/3/16	CBL-EX-PWR-C19-CH	 #021263
Europe (except Italy, Switzerland, and United Kingdom)	250 VAC, 16 A, 50 Hz	CEE (7) VII Type VIIG	CBL-EX-PWR-C19-EU	 #021264
India	250 AC, 16 A, 50 Hz	SABS 164/1:1992 Type ZA/3	CBL-EX-PWR-C19-SA	 #021271
Israel	250 AC, 16 A, 50 Hz	SI 32/1971 Type IL/3	CBL-EX-PWR-C19-IL	 #021265
Italy	250 VAC, 16 A, 50 Hz	CEI 23-16 Type I/3/16	CBL-EX-PWR-C19-IT	 #021266
Japan	250 VAC, 16 A, 60 Hz	NEMA 6-20 Type N6/20	CBL-EX-PWR-C19-JP (default)	 #021267
	250 VAC, 16 A, 60 Hz	NEMA L6-20P Type NEMA Locking	CBL-EX-PWR-C19-JPL	 #021268

Table 86: AC Power Cord Specifications for JNP10K-PWR-AC Power Supplies (Continued)

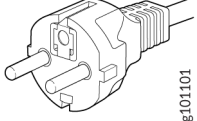
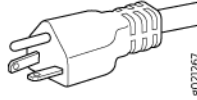
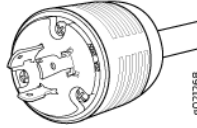
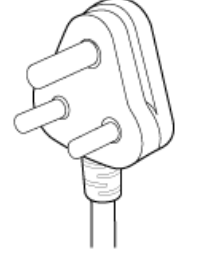
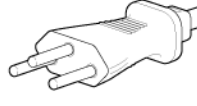

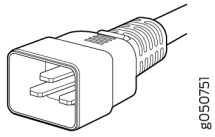
Country/Region	Electrical Specifications	Plug Standards	Juniper Model Number	Graphic
Korea	250 VAC, 16 A, 50 Hz	CEE (7) VII Type VIIG	CBL-EX-PWR-C19-KR	 #101101
North America	250 VAC, 16 A, 60 Hz	NEMA 6-20 Type N6/20	CBL-EX-PWR-C19-US (default)	 #021267
	250 VAC, 16 A, 60 Hz	NEMA L6-20P Type NEMA Locking	CBL-EX-PWR-C19-USL	 #021268
South Africa	250 VAC, 16 A, 50 Hz	SABS 164/1:1992 Type ZA/3	CBL-EX-PWR-C19-SA	 #021289
Switzerland	250 VAC, 16 A, 50 Hz	SEV 5934/2 Type 23G	CBL-EX-PWR-C19-SZ	 #050617
United Kingdom	250 VAC, 13 A, 50 Hz	BS 1363/A Type BS89/13	CBL-EX-PWR-C19-UK	 #021271

Table 86: AC Power Cord Specifications for JNP10K-PWR-AC Power Supplies (*Continued*)

Country/Region	Electrical Specifications	Plug Standards	Juniper Model Number	Graphic
Worldwide (except Japan)	250 VAC, 16 A, 50 Hz	EN 60320-2-2/1	CBL-EX-PWR-C19-C20	

JNP10K-PWR-AC2 Power Cable Specifications

The JNP10K-PWR-AC2 power supply operates in two modes:

- ["JNP10K-PWR-AC2 Power Cable Specifications for 30-A Input" on page 229](#) shows cables and connectors for 30-A input with 5500-W output. One end of the cable has a type SAF-D-GRID Series (3-5958P4) Anderson APP-400 connector, rated 30A/400V/105C, while the other end of the cable is bare wire.
- [Table 87 on page 227](#) shows cables appropriate for 20-A input with 3000-W output. One end of the cable has a type SAF-D-GRID Series (3-5958P4) Anderson APP-400 connector, rated 30A/400V/105C. An example of the connector is shown in [Figure 79 on page 229](#).



WARNING: Do not run JNP10K-PWR-AC2 power supplies using 16-A or 20-A cables if connected to 30-A input.



CAUTION: You can prevent AC power cables from being exposed to hot air exhaust by always routing the power cables away from the fan trays and power supplies.



CAUTION: It is important to connect both input feeds of the JNP10K-PWR-AC2 power supply to AC mains before loading the system with power.

Table 87: JNP10K-PWR-AC2 Power Cable Specifications for 20-A Input

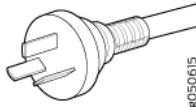
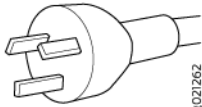
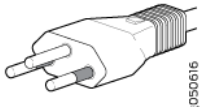
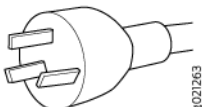
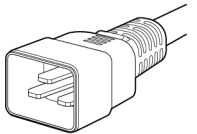
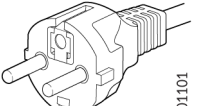

Locale	Cord Set Rating	Plug Standards	Spare Juniper Model Number	Graphic
Argentina	16 A, 250 VAC	IRAM 2073 Type RA/3	CBL-JNP-SG4-AR	 8050615
Australia and New Zealand	15 A, 250 VAC	AS/NZS 3112	CBL-JNP-SG4-AU	 8021262
Brazil	16 A, 250 VAC	NBR 14136 Type BR/3	CBL-JNP-SG4-BR	 8050616
China	16 A, 250 VAC	GB2099	CBL-JNP-SG4-CH	 8021263
China, Europe, and Japan	16 A, 250 VAC	C20 to Anderson 3-5958p4	CBL-JNP-SG4-C20-CH	 8050751
Europe (except Italy, Switzerland, and United Kingdom)	20 A, 250 VAC	CEE 7/7	CBL-JNP-SG4-EU	 8101101
Great Britain	13 A, 250 VAC,	BS1363	CBL-JNP-SG4-UK	 8021271

Table 87: JNP10K-PWR-AC2 Power Cable Specifications for 20-A Input (Continued)


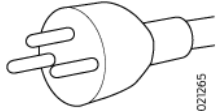

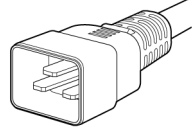
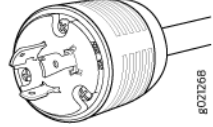
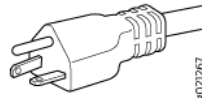
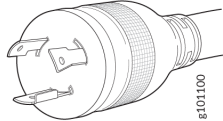
Locale	Cord Set Rating	Plug Standards	Spare Juniper Model Number	Graphic
India	16 A, 250 VAC	SANS 164/1	CBL-JNP-SG4-SA	 #021270
Israel	16 A, RA, 250 VAC	SI 32/1971 Type IL/3C	CBL-JNP-SG4-IL	 #021265
Italy	16 A, 250 VAC	CEI 23-50	CBL-JNP-SG4-IT	 #021266
North America	20 A, 250 VAC	C20 to Anderson 3-5958p4	CBL-JNP-SG4-C20	 #050751
	16 A, 250 VAC	Locking NEMA L6-20P	CBL-JNP-SG4-US-L	 #021268
		NEMA 6-20P	CBL-JNP-SG4-US	 #021267
	20 A, 277 V	NEMA 17-20P	CBL-JNP-SG4-HVAC	 #101100

Table 87: JNP10K-PWR-AC2 Power Cable Specifications for 20-A Input (Continued)

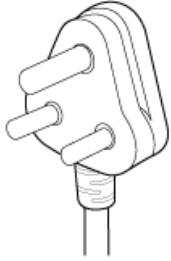

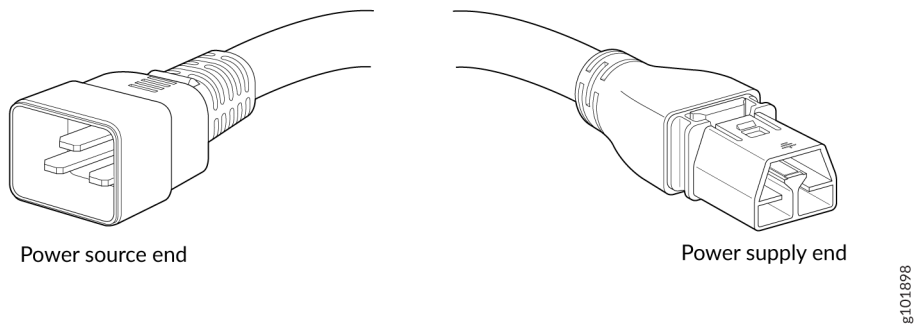
Locale	Cord Set Rating	Plug Standards	Spare Juniper Model Number	Graphic
South Africa	16 A, 250 VAC	SANS 164/1	CBL-JNP-SG4-SA	 #021289
Switzerland	16 A, 250 VAC	CEI 23-50	CBL-JNP-SG4-SZ	 #02266

Figure 79: Bare Cable with Anderson Connector



JNP10K-PWR-AC2 Power Cable Specifications for 30-A Input

The JNP10K-PWR-AC2 AC or HVDC power supply require a high current cable assembly when set for 30-A input. One end of the cable has a type SAF-D-GRID Series (3-5958P4) Anderson APP-400 connector, rated 30A/400V/105C, while the other end of the cable is bare wire. See [Figure 80 on page 230](#) and [Table 88 on page 230](#). These cables are separately orderable and are not shipped automatically with JNP10K-PWR-AC2 orders. An example of the right-angle cable and connector is shown in [Figure 82 on page 231](#).

For connection to AC systems, Juniper provides a cable with either a NEMA 30-A connector (Figure 80 on page 230) or an IEC 330P6W connector (Figure 81 on page 230).

Figure 80: NEMA 30-A Connector

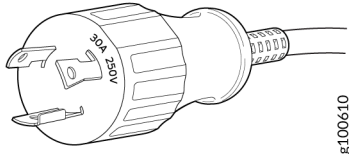


Figure 81: IEC 330P6W Connector

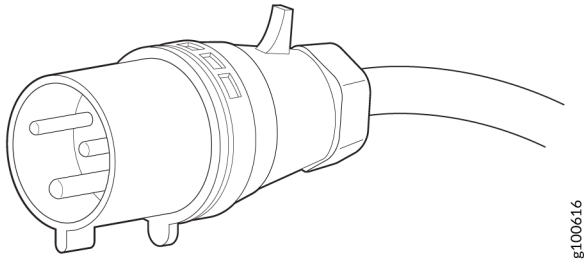


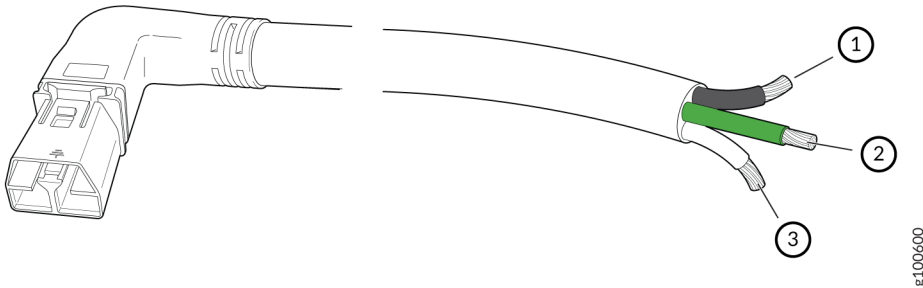
Table 88: 30-A Cabling Options

	Locale	Cord Set Rating	Plug Standards	Connector	Spare Juniper Model Number
AC/HVDC power cord	Any	30-A, 400 VAC	UL 950 and IEC 60950	Anderson/straight to bare wire	CBL-PWR2-BARE
		30-A, 400 VAC	UL 950 and IEC 60950	Anderson/right-angle to bare wire	CBL-PWR2-BARE-RA
AC power cord	Continental Europe	30-A 250 VAC	UL 950 and IEC332P6	Anderson/right-angle to IEC 332P6	CBL-PWR2-332P6W-RA
		30-A 250 VAC	UL 950 and IEC332P6	Anderson/straight to IEC332P6	CBL-PWR2-332P6W

Table 88: 30-A Cabling Options (Continued)

	Locale	Cord Set Rating	Plug Standards	Connector	Spare Juniper Model Number
	North America	30-A 250 VAC	IEC330P6	Anderson/right-angle to IEC 330P6	CBL-PWR2-330P6W-RA
		30-A 250 VAC	IEC330P6	Anderson/straight to IEC 330P6	CBL-PWR2-330P6W
		30-A 250 VAC	UL 498, CSA	Anderson/right-angle to L6-30P (NEMA-30A)	CBL-PWR2-L6-30P-RA
		30-A 250 VAC	UL 498, IEC5958P4	Anderson/straight to L6-30P (NEMA-30A)	CBL-PWR2-L6-30P

Figure 82: Right-Angle, Bare Cable with Anderson Connector



1- Black wire - "+" or "-" for HVDC and "Hot or neutral" for AC	3- White wire - "+" or "-" for HVDC and "Hot or neutral" for AC
2- Green wire - Ground	

JNP10K-PWR-AC3 Power Cable Specifications

The JNP10K-PWR-AC3 power supply operates in two modes:

- 20-A input with 7800 W or 6000 W or 3000 W output
- 15-A input with 7800 W or 7500 W, or 5000 W, or 2500 W output

NOTE: When power cords with right angle plugs at the PSU end are selected, they must be in pairs of Right Angle Left Plugs for inputs A0 or B0 and Extended Right Angle Left Plugs for inputs A1 or B1.

See [Table 89 on page 232](#) for a list of appropriate cables.



WARNING: Do not run JNP10K-PWR-AC3 power supplies using 16-A or 20-A cables if connected to 15-A input.



CAUTION: You can prevent AC power cables from being exposed to hot air exhaust by always routing the power cables away from the fan trays and power supplies.

With right angle power cords and the baffle installed, the power cords will be exposed to hot exhaust air. The IEC C21 plugs have a temperature rating of 155C and the power cord cables have a rating of 90C.

Table 89: JNP10K-PWR-AC3 Power Cable Specifications for 20-A and 15-A Input

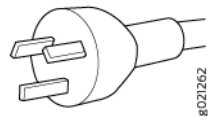
Locale	Cord Set Rating	Plug Standard	Spare Juniper Model Number	Graphic
Straight Plug at PSU Input				
Australia and New Zealand	15 A, 250 VAC	AS/NZS 3112	CBL-PWRC21-AU	

Table 89: JNP10K-PWR-AC3 Power Cable Specifications for 20-A and 15-A Input (Continued)

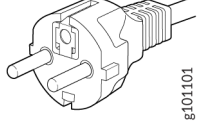

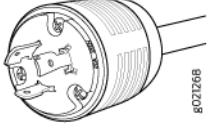
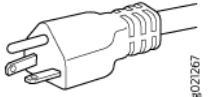
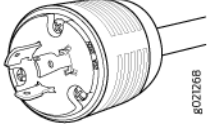

Locale	Cord Set Rating	Plug Standard	Spare Juniper Model Number	Graphic
Europe (except Italy, Switzerland, and United Kingdom)	16A, 250 VAC	CEE 7/7	CBL-PWRC21-EU	 #101101
Italy	16A, 250 VAC	CEI 23-16	CBL-PWRC21-IT	 #021266
North America	20A, 250 VAC	Locking NEMA L6-20P	CBL-PWRC21-US-L	 #021268
		NEMA 6-20P	CBL-PWRC21-US	 #021267
International	16A, 250VAC	IEC-309 316P6W	CBL-PWRC21-316P6	
North America	20A, 250 VAC	IEC-309 320P6W	CBL-PWRC21-320P6	
Japan	20A, 250 VAC	NEMA L6-20P	CBL-PWRC21-JP-L	 #021268
China	16A, 250 VAC	GB2099-1	CBL-PWRC21-CN	 #021263

Table 89: JNP10K-PWR-AC3 Power Cable Specifications for 20-A and 15-A Input (Continued)

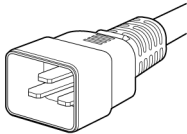
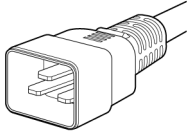
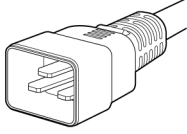
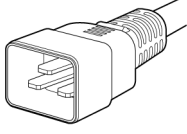
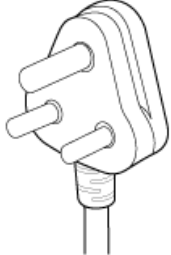
Locale	Cord Set Rating	Plug Standard	Spare Juniper Model Number	Graphic
North America	20A, 250 VAC	IEC-320-C20	CBL-PWRC21-C20-NA	 8050751
Europe	16A, 250 VAC	IEC-320-C20	CBL-PWRC21-C20-EU	 8050751
Japan	20A, 250 VAC	IEC-320-C20	CBL-PWRC21-C20-JP	 8050751
China	16A, 250 VAC	IEC-320-C20	CBL-PWRC21-C20-CN	 8050751
Switzerland	16A, 250 VAC	SEV1011	CBL-PWRC21-SZ	
South Africa	16A, 250 VAC	RA SANs 164/1	CBL-PWRC21-SA	 g021289

Table 89: JNP10K-PWR-AC3 Power Cable Specifications for 20-A and 15-A Input (Continued)

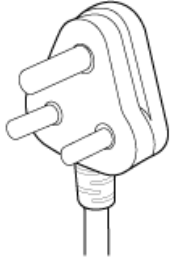

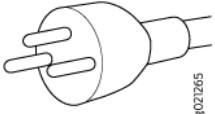
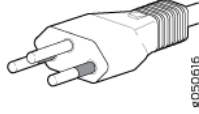
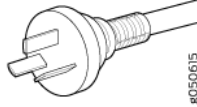
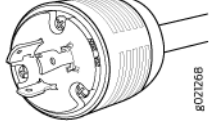
Locale	Cord Set Rating	Plug Standard	Spare Juniper Model Number	Graphic
India	16A, 250VAC	RA IS 1293	CBL-PWRC21-IN	 <p style="text-align: right; font-size: small;">#021289</p>
United Kingdom	16A, 250 VAC	BS 1363	CBL-PWRC21-UK	 <p style="text-align: right; font-size: small;">#021271</p>
Israel	16A, 250 VAC	SI 32/1971 Type IL/3G	CBL-PWRC21-IL	 <p style="text-align: right; font-size: small;">#021265</p>
Brazil	16A, 250 VAC	NBR 14136 Type BR/3	CBL-PWRC21-BR	 <p style="text-align: right; font-size: small;">#050616</p>
Argentina	16A, 250 VAC	IRAM 2073 Type RA/3	CBL-PWRC21-AR	 <p style="text-align: right; font-size: small;">#050615</p>
Right Angle Left Plug at PSU Input				
USA	20A, 250 VAC	NEMA L6-20P	CBL-PWRC21R-US-L	 <p style="text-align: right; font-size: small;">#021268</p>

Table 89: JNP10K-PWR-AC3 Power Cable Specifications for 20-A and 15-A Input (Continued)

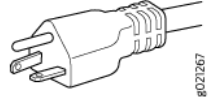
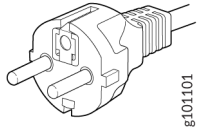
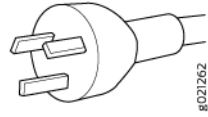

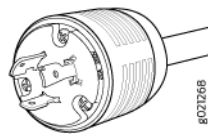
Locale	Cord Set Rating	Plug Standard	Spare Juniper Model Number	Graphic
USA	20A, 250 VAC	NEMA 6-20P	CBL-PWRC21R-US	 #021267
Europe	16A, 250 VAC	CEE 7/7	CBL-PWRC21R-EU	 #101101
Australia	15A, 250 VAC	AS/NZ 3112	CBL-PWRC21R-AU	 #021262
Italy	16A, 250 VAC	CEI 23-50	CBL-PWRC21R-IT	 #021266
International	16A, 250 VAC	IEC 60309 316P6W	CBL-PWRC21R-316P6	
North America	16A, 250VAC	IEC 60309 320P6W	CBL-PWRC21R-320P6	
Japan	20A, 250 VAC	NEMA L6-20P	CBL-PWRC21R-JP-L	 #021266

Table 89: JNP10K-PWR-AC3 Power Cable Specifications for 20-A and 15-A Input (Continued)

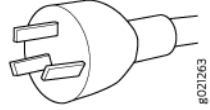
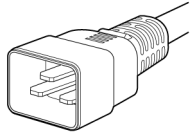
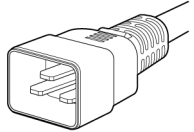
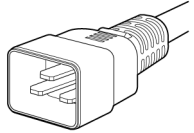
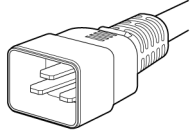
Locale	Cord Set Rating	Plug Standard	Spare Juniper Model Number	Graphic
China	16A, 250 VAC	GB2099-1	CBL-PWRC21R-CN	 #021263
North America	16A, 250 VAC	IEC-60320 C20	CBL-PWRC21R- C20-NA	 #050751
Europe	16A, 250 VAC	IEC 60320 C20	CBL-PWRC21R- C20-EU	 #050751
Japan	20A, 250 VAC	IEC 60320 C20	CBL-PWRC21R- C20-JP	 #050751
China	16A, 250 VAC	IEC 60320 C20	CBL-PWRC21R- C20-CN	 #050751
Switzerland	16A, 250 VAC	SEV 1011	CBL-PWRC21R-SZ	

Table 89: JNP10K-PWR-AC3 Power Cable Specifications for 20-A and 15-A Input (Continued)

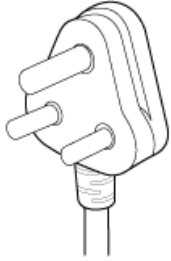
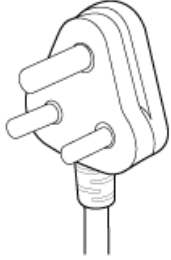

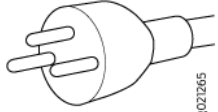
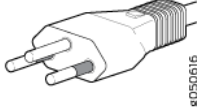
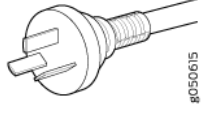
Locale	Cord Set Rating	Plug Standard	Spare Juniper Model Number	Graphic
South Africa	16A, 250 VAC	SANS 164/1	CBL-PWRC21R-SA	 9021289
India	16A, 250 VAC	IS 1293, RA	CBL-PWRC21R-IN	 9021289
United Kingdom	16A, 250 VAC	BS1363	CBL-PWRC21R-UK	 8021271
Israel	16A, 250 VAC	SI 32/1971 TYPE IL/3G	CBL-PWRC21R-IL	 8021265
Brazil	16A, 250 VAC	NBR 14136 TYP BR/3	CBL-PWRC21R-BR	 8050616
Argentina	16A, 250 VAC	IRAM 2073 TYPE RA/3	CBL-PWRC21R-AR	 8050615

Table 89: JNP10K-PWR-AC3 Power Cable Specifications for 20-A and 15-A Input (Continued)

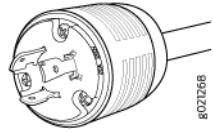
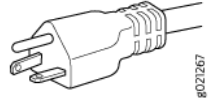
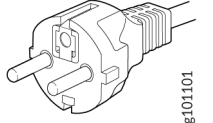
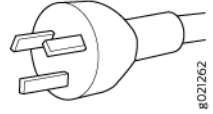

Locale	Cord Set Rating	Plug Standard	Spare Juniper Model Number	Graphic
Extended Right Angle Left Plug at PSU Input				
USA	20A, 250 VAC	NEMA L6-20P	CBL-PWRC21RL-US-L	 #021268
USA	20 A, 250 VAC	NEMA 6-20P	CBL-PWRC21RL-US	 #021267
Europe	16A, 250 VAC	CEE 7/7	CBL-PWRC21RL-EU	 #101101
Australia	15A, 250 VAC	AS/NZ 3112	CBL-PWRC21RL-AU	 #021262
Italy	16A, 250 VAC	CEI 23-50	CBL-PWRC21RL-IT	 #021266
International	16A, 250 VAC	IEC-60309 316P6W	CBL-PWRC21RL-316P6	
North America	20A, 250 VAC	IEC-60309 320P6W	CBL-PWRC21RL-320P6	

Table 89: JNP10K-PWR-AC3 Power Cable Specifications for 20-A and 15-A Input (Continued)

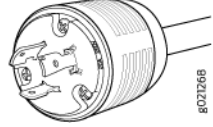
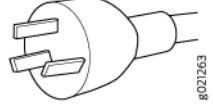
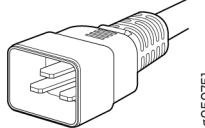
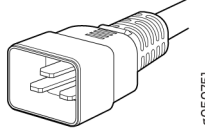
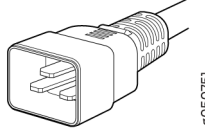
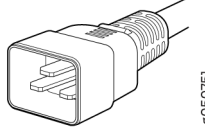
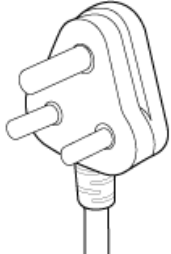
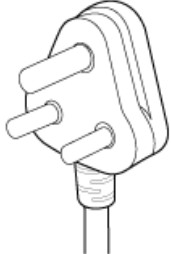

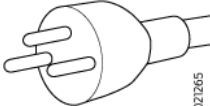
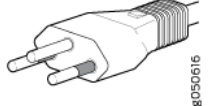
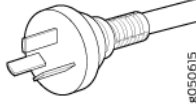
Locale	Cord Set Rating	Plug Standard	Spare Juniper Model Number	Graphic
Japan	20A, 250 VAC	NEMA L6-20P	CBL-PWRC21RL-JP-L	 #021266
China	16A, 250 VAC	GB2099-1	CBL-PWRC21RL-CN	 #021263
North America	20A, 250 VAC	IEC-60320 C20	CBL-PWRC21RL-C20NA	 #050751
Europe	16A, 250 VAC	IEC-60320 C20	CBL-PWRC21RL-C20EU	 #050751
Japan	20A, 250 VAC	ICE-60320 C20	CBL-PWRC21RL-C20JP	 #050751
China	16A, 250 VAC	IEC-60320 C20	CBL-PWRC21RL-C20CN	 #050751
Switzerland	16A, 250 VAC	SEV 1011	CBL-PWRC21RL-SZ	

Table 89: JNP10K-PWR-AC3 Power Cable Specifications for 20-A and 15-A Input (Continued)

Locale	Cord Set Rating	Plug Standard	Spare Juniper Model Number	Graphic
South Africa	16A, 250 VAC	SANS 164/1	CBL-PWRC21RL-SA	 9021289
India	16A, 250 VAC	IS1293, RA	CBL-PWRC21RL-IN	 9021289
United Kingdom	16A, 250 VAC	BS 1363	CBL-PWRC21RL-UK	 8021271
Israel	16A, 250 VAC	SI 32/1971 Type IL/3G	CBL-PWRC21RL-IL	 8021265
Brazil	16A, 250 VAC	NBR 14136 Type BR/3	CBL-PWRC21RL-BR	 8050616
Argentina	16A, 250 VAC	IRAM 2073 Type RA/3	CBL-PWRC21RL-AR	 8050615

JNP10K-PWR-DC Power Specifications

The DC power supply (JNP10K-PWR-DC) is supported only in routers in which you have installed the JNP10008-SF or JNP10016-SF switch fabric. [Table 90 on page 242](#) lists the power specifications for the JNP10K-PWR-DC power supply used in PTX10008 and PTX10016 routers.

Table 90: Power Specifications for the JNP10K-PWR-DC Power Supply

Item	Specifications
DC input voltage	<ul style="list-style-type: none"> • Minimum operating voltage: -40 VDC • Nominal operating voltage: -48 VDC • Operating voltage range: -40 VDC through -72 VDC
DC input current rating	60 A maximum at nominal operating voltage (-48 VDC) for each input terminal
Output power	2500 W

[Table 91 on page 242](#) shows the physical specifications of the JNP10K-PWR-DC power supply.

Table 91: Physical Specifications of the JNP10K-PWR-DC Power Supply

Specification	Value
Height	3.4 in. (8.64 cm)
Width	3.6 in. (9.14 cm)
Depth	14.4 in. (36.58 cm)
Weight	6 lb (2.72 kg)

JNP10K-PWR-DC2 Power Specifications

If you are upgrading a JNP10008-SF system to use JNP10K-PWR-DC2 power supplies, also upgrade your fans and fan tray controllers to ensure the proper airflow. JNP10K-PWR-DC2 power supplies require JNP10008-FAN2 and JNP10008-FTC2 cooling systems. [Table 92 on page 243](#) lists the power specifications for the dual DC power supply used in a PTX10008 chassis.

Table 92: Power Specifications for the JNP10K-PWR-DC2 Power Supply

Item	Specifications
DC input voltage	<ul style="list-style-type: none"> • Minimum operating voltage: -40 VDC • Nominal operating voltage: -48 VDC • Operating voltage range: -40 VDC through -72 VDC
DC input current rating	<ul style="list-style-type: none"> • 76-A maximum at minimum operating voltage (-40 VDC) with 80-A DIP switch setting and 5500-W output load • 64-A maximum at nominal operating voltage (-48 VDC) with 80-A DIP switch setting and 5500-W output load • 60-A maximum at minimum operating voltage (-40 VDC) with 60-A DIP switch setting and 4400-W output load • 50-A maximum at nominal operating voltage (-48 VDC) with 60-A DIP switch setting and 4400-W output load
Output power	<p>2200 W for low input (60-A) single feed</p> <p>4400 W for low input (60-A) dual feed</p> <p>2750 W for high input (80-A) single feed</p> <p>5500 W for high input (80-A) dual feed</p>

[Table 93 on page 244](#) shows the physical specifications for a JNP10K-PWR-DC2 power supply.

Table 93: Physical Specifications of a JNP10K-PWR-DC2 Power Supply

Specification	Value
Height	3.4 in. (8.64 cm)
Width	3.6 in. (1.63 cm)
Depth	16.05 in. (40.77 cm)
Weight	8.6 lb (3.9 kg)

RELATED DOCUMENTATION

[JNP10K-PWR-AC Power Supply | 76](#)

[JNP10K-PWR-AC Power Supply LEDs | 90](#)

[JNP10K-PWR-DC Power Supply | 86](#)

[JNP10K-PWR-DC Power Supply LEDs | 97](#)

PTX10008 Power Planning for JNP10008-SF3 Switch Fabric

IN THIS SECTION

- [Power Requirements for PTX10008 Components in a JNP10008-SF3 Fabric | 245](#)
- [JNP10K-PWR-AC2 Power Specifications | 246](#)
- [JNP10K-PWR-AC2 Power Cable Specifications | 247](#)
- [JNP10K-PWR-AC3 Power Specifications | 254](#)
- [JNP10K-PWR-AC3 Power Cable Specifications | 255](#)
- [JNP10K-PWR-DC2 Power Specifications | 266](#)

Use this information to calculate the power consumption for the PTX10008 running the JNP10008-SF3 switch fabric and plan your configuration's power requirements.

Power Requirements for PTX10008 Components in a JNP10008-SF3 Fabric

Table 94 on page 245 lists the power requirements for the PTX10008 router running the JNP10008-SF3 under typical voltage conditions and optics.

NOTE: The power management considers the values in the column titled 'Default Power Considered' in Table 94 on page 245 to determine the power requirement when a new component is installed. You can disable the default power management by using the *no-power-budget* command.

Table 94: Power Consumption JNP10008-SF3 Fabric Systems Running 14.4 Tbps Line Cards

Component	Description	At 25° C	At 40° C	Default Power Considered
JNP10008-SF3	PTX10008 Switch Interface Board	655 W	672 W	680 W
JNP10008-FAN2	PTX10008 fan tray	600 W	1280 W	1265 W
JNP10K-RE1-E	PTX10008 Routing Control Board for Junos OS Evolved systems	100 W	150 W	200 W
PTX10K-LC1201-36CD	PTX10008 36-port QSFP56-DD line card (without optical transceivers)	If the router has Junos OS Evolved Release 21.4 or earlier installed in it		2360 W
		976 W	1008 W	

Table 94: Power Consumption JNP10008-SF3 Fabric Systems Running 14.4 Tbps Line Cards
(Continued)

Component	Description	At 25° C	At 40° C	Default Power Considered
		If the router has Junos OS Evolved Release 22.1 or later installed in it		
		918 W	948 W	
PTX10K-LC1202-36MR	PTX10008 line card with thirty-two QSFP28 ports and four QSFP56-DD ports (without optical transceivers)	740 W	750 W	1150 W



CAUTION: To ensure adequate power and to avoid raising a power alarm, we recommend that you maintain $n + 1$ power supplies in your router at all times. Replace failed power supplies immediately to prevent unexpected failures.

If a new line card is installed in an operational router, power management does not power on the line card if the increased power demand exceeds the total available power, including redundant power. If redundant power is used to power on the line card, a minor alarm is raised, which becomes a major alarm in five minutes if the condition is not corrected.

You can view the total power provided to the chassis, the power required to operate the chassis and the components installed in it, and the balance power available in the chassis by using the [show chassis power detail](#) command.

JNP10K-PWR-AC2 Power Specifications

The JNP10K-PWR-AC2 power supply supports AC, HVAC, and HVDC. You can run the JNP10K-PWR-AC2 power supply in either JNP10008-SF or in JNP10008-SF3 fabric systems. However, if you are upgrading a JNP10008-SF system to use JNP10K-PWR-AC2 power supplies, also upgrade your fans and fan tray controllers to ensure the proper airflow. JNP10K-PWR-AC2 power supplies require JNP10008-FAN2 and JNP10008-FTC2 cooling systems.

Table 95 on page 247 lists the power specifications for the AC power supply (JNP10K-PWR-AC2) used in a PTX10008 chassis.

Table 95: Power Specifications for a JNP10K-PWR-AC2 Power Supply

Item	Specifications
AC input voltage	180–305 VAC
DC input voltage	190–410 VDC
Input current rating	28.5 A
DC output power	5500 W with dual feed and 5000 W with single feed

Table 96 on page 247 shows the physical specifications for a JNP10K-PWR-AC2 power supply.

Table 96: Physical Specifications for a JNP10K-PWR-AC2 Power Supply

Specification	Value
Height	3.5 in. (8.89 cm)
Width	3.6 in. (9.14 cm)
Depth	15.1 in. (38.35 cm)
Weight	11.4 lb (5.17 kg)

JNP10K-PWR-AC2 Power Cable Specifications

IN THIS SECTION

- [JNP10K-PWR-AC2 Power Cable Specifications | 248](#)

- [JNP10K-PWR-AC2 Power Cable Specifications for 30-A Input | 252](#)

Most sites distribute power through a main conduit that leads to frame-mounted power distribution panels, one of which can be located at the top of the rack that houses the router. An AC power cord connects each power supply to the power distribution panel.

NOTE: In North America, AC power cords must not exceed 15 feet (approximately 4.5 meters) in length, to comply with National Electrical Code (NEC) Sections 400-8 (NFPA 75, 5-2.2) and 210-52 and Canadian Electrical Code (CEC) Section 4-010(3). The cords shipped with the router to North America and Canada are in compliance.

PTX10008 AC, high-voltage alternating current (HVAC), and high-voltage direct current (HVDC) power supplies have specific cord requirements. Use the following sections to determine the cable requirements based on the model of your power supply and any mode settings:

- For JNP10K-PWR-AC2 with 20-A input and 3000-W output, see "[JNP10K-PWR-AC2 Power Cable Specifications](#)" on page 248
- For JNP10K-PWR-AC2 with 30-A input and 5500-W output, see "[JNP10K-PWR-AC2 Power Cable Specifications for 30-A Input](#)" on page 252

JNP10K-PWR-AC2 Power Cable Specifications

When the JNP10K-PWR-AC2 power supply is operating in 20-A mode, it has an output of 2700-W with a single feed and 3000-W with dual feeds. [Table 97 on page 249](#) shows the cables appropriate for 20-A input. [Table 98 on page 252](#) shows the cable appropriate for HVAC input. One end of the cable has a type SAF-D-GRID Series (3-5958P4) Anderson APP-400 connector, rated 30A/400V/105C. An example of the connector is shown in [Figure 83 on page 251](#).



WARNING: Do not run JNP10K-PWR-AC2 power supplies using 16-A or 20-A cables if connected to 30-A input.



CAUTION: You can prevent AC power cables from being exposed to hot air exhaust by always routing the power cables away from the fan trays and power supplies.



CAUTION: It is important to connect both input feeds of the JNP10K-PWR-AC2 power supply to AC mains before loading the system with power.

NOTE: The cables that we ship are 4.5 m long and come with AWG or mm² wire size depending on your country or region.

Table 97: JNP10K-PWR-AC2 Power Cable Specifications for 20-A Input

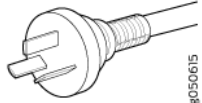
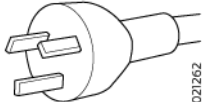

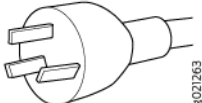
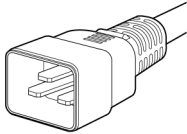
Locale	Cord Set Rating	Plug Standards	Spare Juniper Model Number	Graphic
Argentina	16 A, 250 VAC	IRAM 2073 Type RA/3	CBL-JNP-SG4-AR	 #050615
Australia and New Zealand	15 A, 250 VAC	AS/NZS 3112	CBL-JNP-SG4-AU	 #021262
Brazil	16 A, 250 VAC	NBR 14136 Type BR/3	CBL-JNP-SG4-BR	 #050616
China	16 A, 250 VAC	GB2099	CBL-JNP-SG4-CH	 #021263
China, Europe, and Japan	16 A, 250 VAC	C20 to Anderson 3-5958p4	CBL-JNP-SG4-C20-CH	 #050751

Table 97: JNP10K-PWR-AC2 Power Cable Specifications for 20-A Input (Continued)

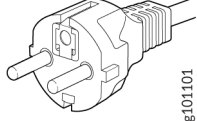


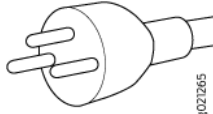

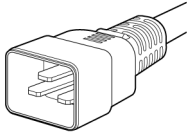
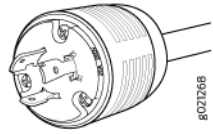
Locale	Cord Set Rating	Plug Standards	Spare Juniper Model Number	Graphic
Europe (except Italy, Switzerland, and United Kingdom)	20 A, 250 VAC	CEE 7/7	CBL-JNP-SG4-EU	 #101101
Great Britain	13 A, 250 VAC,	BS1363	CBL-JNP-SG4-UK	 #021271
India	16 A, 250 VAC	SANS 164/1	CBL-JNP-SG4-SA	 #021270
Israel	16 A, RA, 250 VAC	SI 32/1971 Type IL/3C	CBL-JNP-SG4-IL	 #021265
Italy	16 A, 250 VAC	CEI 23-50	CBL-JNP-SG4-IT	 #021266
North America	20 A, 250 VAC	3-5958P4 to IEC 60320 C20	CBL-JNP-SG4-C20	 #050751
	16 A, 250 VAC	Locking NEMA L6-20P	CBL-JNP-SG4-US-L	 #021268

Table 97: JNP10K-PWR-AC2 Power Cable Specifications for 20-A Input (Continued)

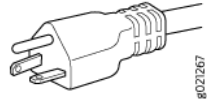
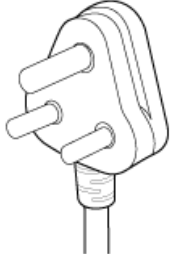

Locale	Cord Set Rating	Plug Standards	Spare Juniper Model Number	Graphic
		NEMA 6-20P	CBL-JNP-SG4-US	 #021267
South Africa	16 A, 250 VAC	SANS 164/1	CBL-JNP-SG4-SA	 #021269
Switzerland	16 A, 250 VAC	CEI 23-50	CBL-JNP-SG4-SZ	 #021266

Figure 83: Bare Cable with Anderson Connector

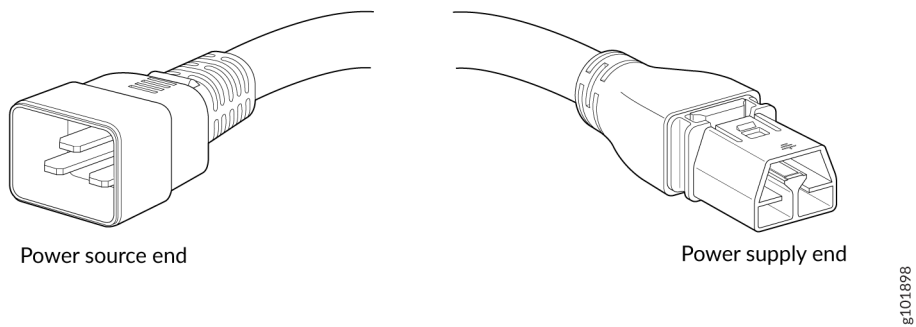
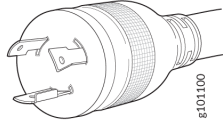


Table 98: JNP10K-PWR-AC2 Power Cable Specifications for HVAC Input

Locale	Cord Set Rating	Plug Standard	Spare Juniper Model Number	Graphic
North America	16 A, 277 V	NEMA L7-20P	CBL-JNP-SG4-HVAC	

JNP10K-PWR-AC2 Power Cable Specifications for 30-A Input

The JNP10K-PWR-AC2 AC or HVDC power supply require a high voltage cable assembly when set for 30-A input. One end of the cable has a type SAF-D-GRID Series (3-5958P4) Anderson APP-400 connector, rated 30A/400V/105C, while the other end of the cable is bare wire. See [Figure 84 on page 252](#) and [Table 99 on page 253](#). These cables are separately orderable and are not shipped automatically with JNP10K-PWR-AC2 orders. An example of the right-angle cable and connector is shown in [Figure 86 on page 254](#).

For connection to AC systems, Juniper provides a cable with either a NEMA 30-A connector ([Figure 84 on page 252](#)) or an IEC 330P6W connector ([Figure 85 on page 253](#)).

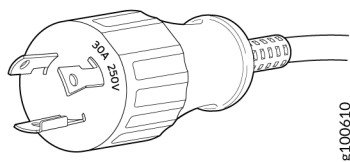
Figure 84: NEMA 30-A Connector

Figure 85: IEC 330P6W Connector

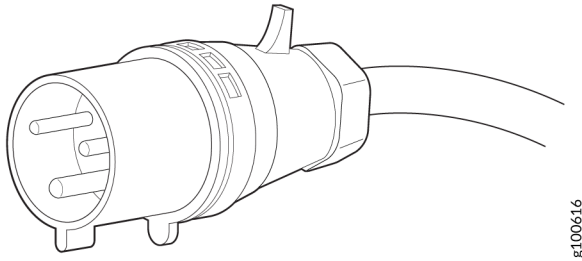


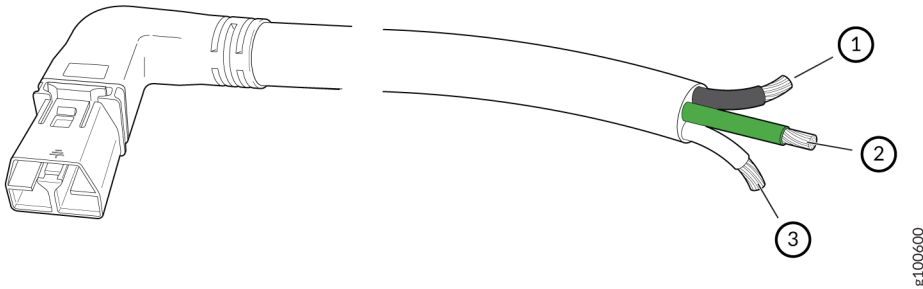
Table 99: 30-A Cabling Options

Description	Locale	Cord Set Rating	Plug Standards	Connector	Spare Juniper Model Number
AC/HVDC power cord	Any	30-A, 400 VAC	UL 950 and IEC 60950	Anderson/straight to bare wire	CBL-PWR2-BARE
		30-A, 400 VAC	UL 950 and IEC 60950	Anderson/right-angle to bare wire	CBL-PWR2-BARE-RA
AC power cord	Continental Europe	30-A 250 VAC	UL 950 and IEC332P6	Anderson/right-angle to IEC 332P6	CBL-PWR2-332P6W-RA
		30-A 250 VAC	UL 950 and IEC332P6	Anderson/straight to IEC332P6	CBL-PWR2-332P6W
	North America	30-A 250 VAC	IEC330P6	Anderson/right-angle to IEC 330P6	CBL-PWR2-330P6W-RA
		30-A 250 VAC	IEC330P6	Anderson/straight to IEC 330P6	CBL-PWR2-330P6W
		30-A 250 VAC	UL 498, CSA	Anderson/right-angle to L6-30P (NEMA-30A)	CBL-PWR2-L6-30P-RA

Table 99: 30-A Cabling Options (Continued)

Description	Locale	Cord Set Rating	Plug Standards	Connector	Spare Juniper Model Number
		30-A 250 VAC	UL 498, IEC5958P4	Anderson/straight to L6-30P (NEMA-30A)	CBL-PWR2-L6-30P

Figure 86: Right-Angle, Bare Cable with Anderson Connector



1– Black wire - “+” or “-” for HVDC and “Hot or neutral” for AC	3– White wire - “+” or “-” for HVDC and “Hot or neutral” for AC
2– Green wire - Ground	

JNP10K-PWR-AC3 Power Specifications

The JNP10K-PWR-AC3 power supply supports AC.

[Table 100 on page 255](#) lists the power specifications for the AC power supply (JNP10K-PWR-AC3) used in a PTX10004 chassis.

Table 100: Power Specifications for a JNP10K-PWR-AC3 Power Supply

Specification	Value
AC input voltage	180–264 VAC
Input current rating	16 A
DC output power	12.3 V

[Table 101 on page 255](#) shows the physical specifications for a JNP10K-PWR-AC3 power supply.

Table 101: Physical Specifications for a JNP10K-PWR-AC3 Power Supply

Specification	Value
Height	3.386 in. (8.60 cm)
Width	3.584 in. (9.10 cm)
Depth	17.15 (43.57 cm)
Weight	12.8 lbs (5.8 kg)

JNP10K-PWR-AC3 Power Cable Specifications

The JNP10K-PWR-AC3 power supply operates in two modes:

- 20-A input with 7800 W or 6000 W or 3000 W output
- 15-A input with 7800 W or 7500 W, or 5000 W, or 2500 W output

NOTE: When power cords with right angle plugs at the PSU end are selected, they must be in pairs of Right Angle Left Plugs for inputs A0 or B0 and Extended Right Angle Left Plugs for inputs A1 or B1.

See [Table 102 on page 256](#) for a list of appropriate cables.



WARNING: Do not run JNP10K-PWR-AC3 power supplies using 16-A or 20-A cables if connected to 15-A input.



CAUTION: You can prevent AC power cables from being exposed to hot air exhaust by always routing the power cables away from the fan trays and power supplies.

With right angle power cords and the baffle installed, the power cords will be exposed to hot exhaust air. The IEC C21 plugs have a temperature rating of 155C and the power cord cables have a rating of 90C.

Table 102: JNP10K-PWR-AC3 Power Cable Specifications for 20-A and 15-A Input

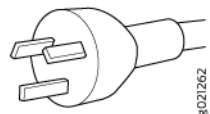
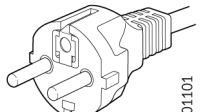

Locale	Cord Set Rating	Plug Standard	Spare Juniper Model Number	Graphic
Straight Plug at PSU Input				
Australia and New Zealand	15 A, 250 VAC	AS/NZS 3112	CBL-PWRC21-AU	 #021262
Europe (except Italy, Switzerland, and United Kingdom)	16A, 250 VAC	CEE 7/7	CBL-PWRC21-EU	 #101101
Italy	16A, 250 VAC	CEI 23-16	CBL-PWRC21-IT	 #021266

Table 102: JNP10K-PWR-AC3 Power Cable Specifications for 20-A and 15-A Input (Continued)

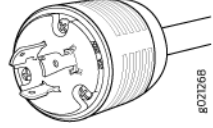
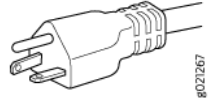
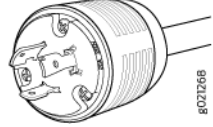
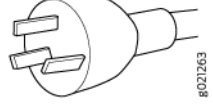
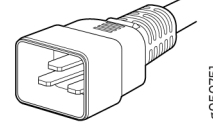
Locale	Cord Set Rating	Plug Standard	Spare Juniper Model Number	Graphic
North America	20A, 250 VAC	Locking NEMA L6-20P	CBL-PWRC21-US-L	 8021268
		NEMA 6-20P	CBL-PWRC21-US	 8021267
International	16A, 250VAC	IEC-309 316P6W	CBL-PWRC21-316P6	
North America	20A, 250 VAC	IEC-309 320P6W	CBL-PWRC21-320P6	
Japan	20A, 250 VAC	NEMA L6-20P	CBL-PWRC21-JP-L	 8021268
China	16A, 250 VAC	GB2099-1	CBL-PWRC21-CN	 8021263
North America	20A, 250 VAC	IEC-320-C20	CBL-PWRC21-C20-NA	 8050751

Table 102: JNP10K-PWR-AC3 Power Cable Specifications for 20-A and 15-A Input (Continued)

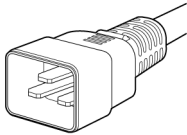
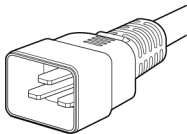
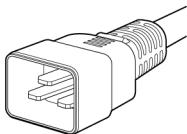
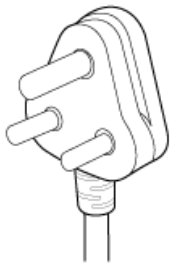
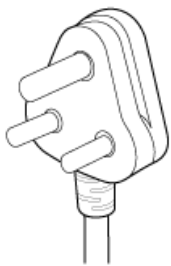

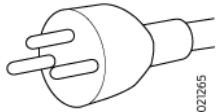

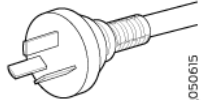
Locale	Cord Set Rating	Plug Standard	Spare Juniper Model Number	Graphic
Europe	16A, 250 VAC	IEC-320-C20	CBL-PWRC21-C20-EU	 8050751
Japan	20A, 250 VAC	IEC-320-C20	CBL-PWRC21-C20-JP	 8050751
China	16A, 250 VAC	IEC-320-C20	CBL-PWRC21-C20-CN	 8050751
Switzerland	16A, 250 VAC	SEV1011	CBL-PWRC21-SZ	
South Africa	16A, 250 VAC	RA SANs 164/1	CBL-PWRC21-SA	 g021289
India	16A, 250VAC	RA IS 1293	CBL-PWRC21-IN	 g021289

Table 102: JNP10K-PWR-AC3 Power Cable Specifications for 20-A and 15-A Input (Continued)

Locale	Cord Set Rating	Plug Standard	Spare Juniper Model Number	Graphic
United Kingdom	16A, 250 VAC	BS 1363	CBL-PWRC21-UK	 #021271
Israel	16A, 250 VAC	SI 32/1971 Type IL/3G	CBL-PWRC21-IL	 #021265
Brazil	16A, 250 VAC	NBR 14136 Type BR/3	CBL-PWRC21-BR	 #050616
Argentina	16A, 250 VAC	IRAM 2073 Type RA/3	CBL-PWRC21-AR	 #050615

Right Angle Left Plug at PSU Input

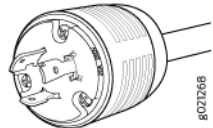
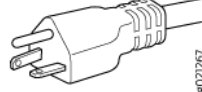
USA	20A, 250 VAC	NEMA L6-20P	CBL-PWRC21R-US-L	 #021268
USA	20A, 250 VAC	NEMA 6-20P	CBL-PWRC21R-US	 #021267

Table 102: JNP10K-PWR-AC3 Power Cable Specifications for 20-A and 15-A Input (Continued)

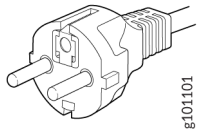
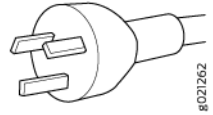

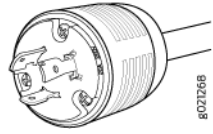
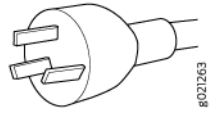
Locale	Cord Set Rating	Plug Standard	Spare Juniper Model Number	Graphic
Europe	16A, 250 VAC	CEE 7/7	CBL-PWRC21R-EU	
Australia	15A, 250 VAC	AS/NZ 3112	CBL-PWRC21R-AU	
Italy	16A, 250 VAC	CEI 23-50	CBL-PWRC21R-IT	
International	16A, 250 VAC	IEC 60309 316P6W	CBL- PWRC21R-316P6	
North America	16A, 250VAC	IEC 60309 320P6W	CBL- PWRC21R-320P6	
Japan	20A, 250 VAC	NEMA L6-20P	CBL-PWRC21R-JP-L	
China	16A, 250 VAC	GB2099-1	CBL-PWRC21R-CN	

Table 102: JNP10K-PWR-AC3 Power Cable Specifications for 20-A and 15-A Input (Continued)

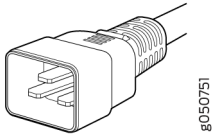
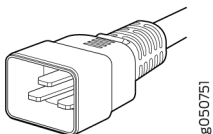
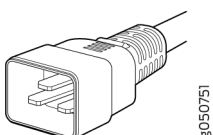
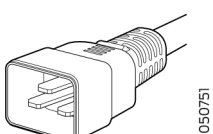
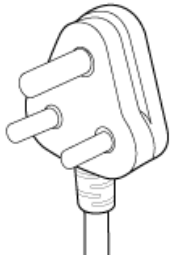
Locale	Cord Set Rating	Plug Standard	Spare Juniper Model Number	Graphic
North America	16A, 250 VAC	IEC-60320 C20	CBL-PWRC21R- C20-NA	 8050751
Europe	16A, 250 VAC	IEC 60320 C20	CBL-PWRC21R- C20-EU	 8050751
Japan	20A, 250 VAC	IEC 60320 C20	CBL-PWRC21R- C20-JP	 8050751
China	16A, 250 VAC	IEC 60320 C20	CBL-PWRC21R- C20-CN	 8050751
Switzerland	16A, 250 VAC	SEV 1011	CBL-PWRC21R-SZ	
South Africa	16A, 250 VAC	SANS 164/1	CBL-PWRC21R-SA	 9021289

Table 102: JNP10K-PWR-AC3 Power Cable Specifications for 20-A and 15-A Input (Continued)

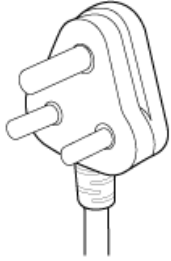

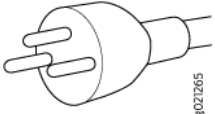
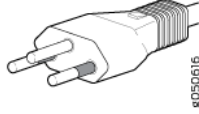
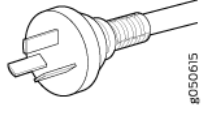
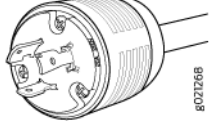
Locale	Cord Set Rating	Plug Standard	Spare Juniper Model Number	Graphic
India	16A, 250 VAC	IS 1293, RA	CBL-PWRC21R-IN	 8021289
United Kingdom	16A, 250 VAC	BS1363	CBL-PWRC21R-UK	 8021271
Israel	16A, 250 VAC	SI 32/1971 TYPE IL/3G	CBL-PWRC21R-IL	 8021265
Brazil	16A, 250 VAC	NBR 14136 TYP BR/3	CBL-PWRC21R-BR	 8050616
Argentina	16A, 250 VAC	IRAM 2073 TYPE RA/3	CBL-PWRC21R-AR	 8050615
Extended Right Angle Left Plug at PSU Input				
USA	20A, 250 VAC	NEMA L6-20P	CBL-PWRC21RL- US-L	 8021268

Table 102: JNP10K-PWR-AC3 Power Cable Specifications for 20-A and 15-A Input (Continued)

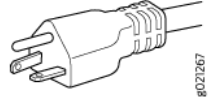
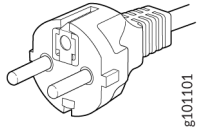
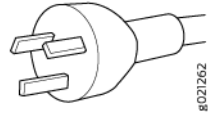

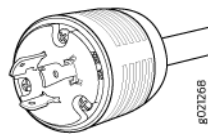
Locale	Cord Set Rating	Plug Standard	Spare Juniper Model Number	Graphic
USA	20 A, 250 VAC	NEMA 6-20P	CBL-PWRC21RL-US	 #021267
Europe	16A, 250 VAC	CEE 7/7	CBL-PWRC21RL-EU	 #101101
Australia	15A, 250 VAC	AS/NZ 3112	CBL-PWRC21RL-AU	 #021262
Italy	16A, 250 VAC	CEI 23-50	CBL-PWRC21RL-IT	 #021266
International	16A, 250 VAC	IEC-60309 316P6W	CBL- PWRC21RL-316P6	
North America	20A, 250 VAC	IEC-60309 320P6W	CBL- PWRC21RL-320P6	
Japan	20A, 250 VAC	NEMA L6-20P	CBL-PWRC21RL-JP- L	 #021266

Table 102: JNP10K-PWR-AC3 Power Cable Specifications for 20-A and 15-A Input (Continued)

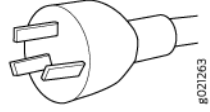
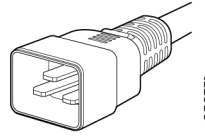
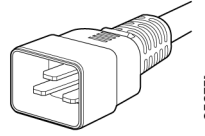
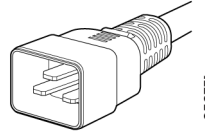
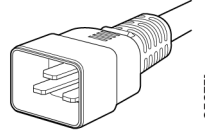
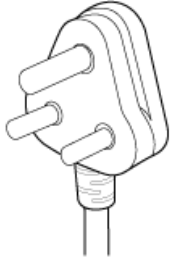
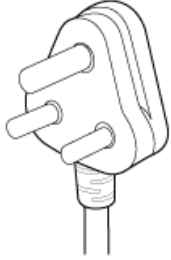

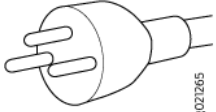
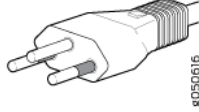
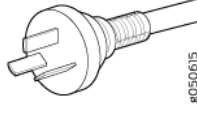
Locale	Cord Set Rating	Plug Standard	Spare Juniper Model Number	Graphic
China	16A, 250 VAC	GB2099-1	CBL-PWRC21RL-CN	 #021263
North America	20A, 250 VAC	IEC-60320 C20	CBL-PWRC21RL- C20NA	 #050751
Europe	16A, 250 VAC	IEC-60320 C20	CBL-PWRC21RL- C20EU	 #050751
Japan	20A, 250 VAC	ICE-60320 C20	CBL-PWRC21RL- C20JP	 #050751
China	16A, 250 VAC	IEC-60320 C20	CBL-PWRC21RL- C20CN	 #050751
Switzerland	16A, 250 VAC	SEV 1011	CBL-PWRC21RL-SZ	

Table 102: JNP10K-PWR-AC3 Power Cable Specifications for 20-A and 15-A Input (Continued)

Locale	Cord Set Rating	Plug Standard	Spare Juniper Model Number	Graphic
South Africa	16A, 250 VAC	SANS 164/1	CBL-PWRC21RL-SA	 9021289
India	16A, 250 VAC	IS1293, RA	CBL-PWRC21RL-IN	 9021289
United Kingdom	16A, 250 VAC	BS 1363	CBL-PWRC21RL-UK	 8021271
Israel	16A, 250 VAC	SI 32/1971 Type IL/3G	CBL-PWRC21RL-IL	 8021265
Brazil	16A, 250 VAC	NBR 14136 Type BR/3	CBL-PWRC21RL-BR	 8050616
Argentina	16A, 250 VAC	IRAM 2073 Type RA/3	CBL-PWRC21RL-AR	 8050615

JNP10K-PWR-DC2 Power Specifications

If you are upgrading a JNP10008-SF system to use JNP10K-PWR-DC2 power supplies, also upgrade your fans and fan tray controllers to ensure the proper airflow. JNP10K-PWR-DC2 power supplies require JNP10008-FAN2 and JNP10008-FTC2 cooling systems. [Table 103 on page 266](#) lists the power specifications for the dual DC power supply used in a PTX10008 chassis.

Table 103: Power Specifications for the JNP10K-PWR-DC2 Power Supply

Item	Specifications
DC input voltage	<ul style="list-style-type: none"> • Minimum operating voltage: -40 VDC • Nominal operating voltage: -48 VDC • Operating voltage range: -40 VDC through -72 VDC
DC input current rating	<ul style="list-style-type: none"> • 76-A maximum at minimum operating voltage (-40 VDC) with 80-A DIP switch setting and 5500-W output load • 64-A maximum at nominal operating voltage (-48 VDC) with 80-A DIP switch setting and 5500-W output load • 60-A maximum at minimum operating voltage (-40 VDC) with 60-A DIP switch setting and 4400-W output load • 50-A maximum at nominal operating voltage (-48 VDC) with 60-A DIP switch setting and 4400-W output load
Output power	<p>2200 W for low input (60-A) single feed</p> <p>4400 W for low input (60-A) dual feed</p> <p>2750 W for high input (80-A) single feed</p> <p>5500 W for high input (80-A) dual feed</p>

[Table 104 on page 267](#) shows the physical specifications for a JNP10K-PWR-DC2 power supply.

Table 104: Physical Specifications of a JNP10K-PWR-DC2 Power Supply

Specification	Value
Height	3.5 in. (8.89 cm)
Width	3.6 in. (1.63 cm)
Depth	16.05 in. (40.77 cm)
Weight	8.1 lb (3.67 kg)

RELATED DOCUMENTATION

[JNP10K-PWR-AC2 Power Supply | 78](#)

[JNP10K-PWR-DC2 Power Supply | 88](#)

[Install and Remove PTX10008 Power System Components | 361](#)

PTX10008 Grounding Cable and Lug Specifications

You must install the router in a restricted-access location and ensure it is adequately grounded at all times. Proper grounding ensures your router is operating correctly and that it meets safety and electromagnetic interference (EMI) requirements. The PTX10008 modular chassis has a 2-hole protective grounding terminal on the rear of the chassis beneath the power supplies for grounding.

For AC powered systems, you must also use the grounding wire in the AC power cord along with the 2-hole lug ground connection. This tested system meets or exceeds all applicable EMC regulatory requirements with the 2-hole protective grounding terminal.



WARNING: To comply with GR-1089 requirements, all intrabuilding copper cabling used for SFP+, QSFP+, and QSFP28 ports must be shielded and grounded at both ends.



CAUTION: Before router installation begins, a licensed electrician must attach a cable lug to the grounding cables that you supply. See "[Connect the PTX10008 Router to Earth Ground](#)" on page 320. A cable with an incorrectly attached lug can damage the router.

Before connecting the router to earth ground, review the following information:

- Two threaded inserts (PEM nuts) are provided on the lower rear of the chassis for connecting the router to earth ground. The grounding points are spaced at 0.63 in. (16 mm) centers.
- The chassis grounding lug required is a Panduit LCD4-14A-L or equivalent (provided). This lug accommodates 4 AWG (21.1mm²) stranded wire. The 4 AWG (21.1 mm²) stranded wire should be rated 90° C, or as permitted by local electrical code.



WARNING: Some early PTX10008 chassis shipped with chassis lugs rated for 6 AWG. If you plan to upgrade your power system to use JNP10K-PWR-DC2 power supplies at the high power setting (80 A), be sure your chassis lug is upgraded the Panduit LCD4-14A-L equivalent.

- The grounding cable that you provide for a PTX10008 must be the same size or heavier than the input wire of each power supply.

RELATED DOCUMENTATION

[Connect AC Power to a PTX10008 | 322](#)

[Connect DC Power to a PTX10008 | 323](#)

PTX10008 Transceiver and Cable Specifications

IN THIS SECTION

- [PTX10008 Optical Transceiver and Cable Support | 269](#)
- [PTX10008 Cable Specifications for Console and Management Connections | 270](#)

- [PTX10008 Fiber-Optic Cable Signal Loss, Attenuation, and Dispersion | 271](#)
- [Calculate the Fiber-Optic Cable Power Budget for a QFX Series Router | 272](#)
- [Calculate the Fiber-Optic Cable Power Margin for a QFX Series Router | 273](#)

Review fiber-optic cable characteristics and plan the power budget and power margin for fiber-optic cables connected to your device by using the information in the following topics.

PTX10008 Optical Transceiver and Cable Support

You can find information about the pluggable transceivers supported on your Juniper Networks device by using the Hardware Compatibility Tool. In addition to transceiver and connector type, the optical and cable characteristics—where applicable—are documented for each transceiver. The Hardware Compatibility Tool enables you to search by product, displaying all the transceivers supported on that device, or category, by interface speed or type. The list of supported transceivers for the PTX10008 is located at <https://apps.juniper.net/hct/home/>.



CAUTION: The Juniper Networks Technical Assistance Center (JTAC) provides complete support for Juniper-supplied optical modules and cables. However, JTAC does not provide support for third-party optical modules and cables that are not qualified or supplied by Juniper Networks. If you face a problem running a Juniper device that uses third-party optical modules or cables, JTAC may help you diagnose host-related issues if the observed issue is not, in the opinion of JTAC, related to the use of the third-party optical modules or cables. Your JTAC engineer will likely request that you check the third-party optical module or cable and, if required, replace it with an equivalent Juniper-qualified component.

Use of third-party optical modules with high-power consumption (for example, coherent ZR or ZR+) can potentially cause thermal damage to or reduce the lifespan of the host equipment. Any damage to the host equipment due to the use of third-party optical modules or cables is the users' responsibility. Juniper Networks will accept no liability for any damage caused due to such use.

SEE ALSO

| [Supported Transceivers](#)

PTX10008 Cable Specifications for Console and Management Connections

Table 105 on page 270 lists the specifications for the cables that connect the PTX10008 router to a management device.

NOTE: The PTX10008 can be configured with SFP management ports that support 1000BASE-SX transceivers.

Table 105: Cable Specifications for Console and Management Connections for the PTX10008 Routers

Port on PTX10008 Router	Cable Specification	Maximum Length	Device Receptacle
Console port	RS-232 (EIA-232) serial cable	2.13 meters	RJ-45
Management port	Category 5 cable or equivalent suitable for 1000BASE-T operation	100 meters	RJ-45

NOTE: We no longer include the RJ-45 console cable with the DB-9 adapter as part of the device package. If the console cable and adapter are not included in your device package, or if you need a different type of adapter, you can order the following separately:

- RJ-45 to DB-9 adapter (JNP-CBL-RJ45-DB9)
- RJ-45 to USB-A adapter (JNP-CBL-RJ45-USBA)
- RJ-45 to USB-C adapter (JNP-CBL-RJ45-USBC)

If you want to use RJ-45 to USB-A or RJ-45 to USB-C adapter you must have X64 (64-Bit) Virtual COM port (VCP) driver installed on your PC. See, <https://ftdichip.com/drivers/vcp-drivers/> to download the driver.

SEE ALSO

[PTX10008 Console and Management Cable Specifications and Pinouts | 275](#)

[Connect a PTX10008 Router to a Management Console | 326](#)

PTX10008 Fiber-Optic Cable Signal Loss, Attenuation, and Dispersion

IN THIS SECTION

- [Signal Loss in Multimode and Single-Mode Fiber-Optic Cables](#) | 271
- [Attenuation and Dispersion in Fiber-Optic Cable](#) | 271

To determine the power budget and power margin needed for fiber-optic connections, you need to understand how signal loss, attenuation, and dispersion affect transmission. The PTX10008 router uses various types of network cables, including multimode and single-mode fiber-optic cables.

Signal Loss in Multimode and Single-Mode Fiber-Optic Cables

Multimode fiber is large enough in diameter to allow rays of light to reflect internally (bounce off the walls of the fiber). Interfaces with multimode optics typically use LEDs as light sources. However, LEDs are not coherent light sources. They spray varying wavelengths of light into the multimode fiber, which reflect the light at different angles. Light rays travel in jagged lines through a multimode fiber, causing signal dispersion. When light traveling in the fiber core radiates into the fiber cladding (layers of lower refractive index material in close contact with a core material of higher refractive index), higher-order mode loss occurs. Together, these factors reduce the transmission distance of multimode fiber compared to that of single-mode fiber.

Single-mode fiber is so small in diameter that rays of light reflect internally through one layer only. Interfaces with single-mode optics use lasers as light sources. Lasers generate a single wavelength of light, which travels in a straight line through the single-mode fiber. Compared to multimode fiber, single-mode fiber has a higher bandwidth and can carry signals for longer distances. It is consequently more expensive.

Attenuation and Dispersion in Fiber-Optic Cable

An optical data link functions correctly provided that modulated light reaching the receiver has enough power to be demodulated correctly. *Attenuation* is the reduction in strength of the light signal during transmission. Passive media components such as cables, cable splices, and connectors cause attenuation. Although attenuation is significantly lower for optical fiber than for other media, it still

occurs in both multimode and single-mode transmission. An efficient optical data link must transmit enough light to overcome attenuation.

Dispersion is the spreading of the signal over time. The following two types of dispersion can affect signal transmission through an optical data link:

- Chromatic dispersion, which is the spreading of the signal over time caused by the different speeds of light rays.
- Modal dispersion, which is the spreading of the signal over time caused by the different propagation modes in the fiber.

For multimode transmission, modal dispersion, rather than chromatic dispersion or attenuation, usually limits the maximum bit rate and link length. For single-mode transmission, modal dispersion is not a factor. However, at higher bit rates and over longer distances, chromatic dispersion limits the maximum link length.

An efficient optical data link must have enough light to exceed the minimum power that the receiver requires to operate within its specifications. In addition, the total dispersion must be within the limits specified for the type of link in the Telcordia Technologies document GR-253-CORE (Section 4.3) and International Telecommunications Union (ITU) document G.957.

When chromatic dispersion is at the maximum allowed, its effect can be considered as a power penalty in the power budget. The optical power budget must allow for the sum of component attenuation, power penalties (including those from dispersion), and a safety margin for unexpected losses.

Calculate the Fiber-Optic Cable Power Budget for a QFX Series Router

Calculate the link's power budget when planning fiber-optic cable layout and distances to ensure that fiber-optic connections have sufficient power for correct operation. The power budget is the maximum amount of power the link can transmit. When you calculate the power budget, you use a worst-case analysis to provide a margin of error, even though all the parts of an actual system don't operate at the worst-case levels.

To calculate the worst-case estimate for the fiber-optic cable power budget (P^B) for the link:

1. Determine values for the link's minimum transmitter power (P_T) and minimum receiver sensitivity (P_R). For example, here (P_T) and (P_R) are measured in decibels, and decibels are referenced to 1 milliwatt (dBm):

$$P_T = -15 \text{ dBm}$$

$$P_R = -28 \text{ dBm}$$

NOTE: See the specifications for your transmitter and receiver to find the minimum transmitter power and minimum receiver sensitivity.

2. Calculate the power budget (P^B) by subtracting (P_R) from (P_T):
 $-15 \text{ dBm} - (-28 \text{ dBm}) = 13 \text{ dBm}$

Calculate the Fiber-Optic Cable Power Margin for a QFX Series Router

Before you begin to calculate the power margin, calculate the power budget.

Calculate the link's power margin when planning fiber-optic cable layout and distances to ensure that fiber-optic connections have sufficient signal power to overcome system losses and still satisfy the minimum input requirements of the receiver for the required performance level. The power margin (P_M) is the amount of power available after attenuation or link loss (LL) has been subtracted from the power budget (P_B).

When you calculate the power margin, you use a worst-case analysis to provide a margin of error, even though all the parts of an actual system don't operate at worst-case levels. A power margin (P_M) greater than zero indicates that the power budget is sufficient to operate the receiver and that it does not exceed the maximum receiver input power. This means the link will work. A (P_M) that is zero or negative indicates insufficient power to operate the receiver. See the specification for your receiver to find the maximum receiver input power.

To calculate the worst-case estimate for the power margin (P_M) for the link:

1. Determine the maximum value for LL by adding estimated values for applicable link-loss factors; for example, use the sample values for various factors as provided in [Table 106 on page 273](#) (here, the link is 2 km long and multimode, and the (P_B) is 13 dBm).

Table 106: Estimated Values for Factors Causing Link Loss

Link-Loss Factor	Estimated Link-Loss Value	Sample Link-Loss Calculation Values
Higher-order mode losses	Multimode—0.5 dBm	0.5 dBm
	Single mode—None	0 dBm

Table 106: Estimated Values for Factors Causing Link Loss (Continued)

Link-Loss Factor	Estimated Link-Loss Value	Sample Link-Loss Calculation Values
Modal and chromatic dispersion	Multimode—None, if product of bandwidth and distance is less than 500 MHz/km	0 dBm
	Single mode—None	0 dBm
Connector	0.5 dBm	This example assumes five connectors. Loss for five connectors: 5 (0.5 dBm) = 2.5 dBm.
Splice	0.5 dBm	This example assumes two splices. Loss for two splices: 2 (0.5 dBm) = 1 dBm.
Fiber attenuation	Multimode—1 dBm/km	This example assumes the link is 2-km long. Fiber attenuation for 2 km: 2 km (1 dBm/km) = 2 dBm.
	Single-mode—0.5 dBm/km	This example assumes the link is 2-km long. Fiber attenuation for 2 km: 2 km (0.5 dBm/km) = 1 dBm.
Clock Recovery Module (CRM)	1 dBm	1 dBm

NOTE: For information about the actual amount of signal loss caused by equipment and other factors, see your vendor documentation for that equipment.

2. Calculate the (P_M) by subtracting (LL) from (P_B):

$$P_B - LL = P_M$$

$$13 \text{ dBm} - 0.5 \text{ dBm [HOL]} - 5 (0.5 \text{ dBm}) - 2 (0.5 \text{ dBm}) - 2 \text{ km} (1.0 \text{ dBm/km}) - 1 \text{ dB [CRM]} = P_M$$

$$13 \text{ dBm} - 0.5 \text{ dBm} - 2.5 \text{ dBm} - 1 \text{ dBm} - 2 \text{ dBm} - 1 \text{ dBm} = P_M$$

$$P_M = 6 \text{ dBm}$$

The calculated power margin is greater than zero, indicating that the link has sufficient power for transmission. Also, the power margin value does not exceed the maximum receiver input power. Refer to the specifications for your receiver to find the maximum receiver input power.

PTX10008 Console and Management Cable Specifications and Pinouts

IN THIS SECTION

- [Console Port Connector Pinouts for a PTX10008 | 275](#)
- [USB Port Specifications for the PTX10008 Router | 277](#)
- [Management Port Connector Pinouts for the PTX10008 Router | 278](#)

The following sections describe the console port, the USB port, and the management port connections and specifications.

Console Port Connector Pinouts for a PTX10008

The console port (labeled **CON**) on the Routing and Control Board panel is an RS-232 serial interface that uses an RJ-45 connector to connect to a console management device. The default baud rate for the console port is 9600 baud.

[Table 107 on page 276](#) provides the pinout information for the RJ-45 console connector.

NOTE: If your laptop or PC does not have a DB-9 plug connector pin and you want to connect your laptop or PC directly to a PTX10008 router, use a combination of an RJ-45 to DB-9 cable and a USB to DB-9 plug adapter. You must provide the USB to DB-9 plug adapter.

NOTE: We no longer include the RJ-45 console cable with the DB-9 adapter as part of the device package. If the console cable and adapter are not included in your device package, or if you need a different type of adapter, you can order the following separately:

- RJ-45 to DB-9 adapter (JNP-CBL-RJ45-DB9)
- RJ-45 to USB-A adapter (JNP-CBL-RJ45-USBA)
- RJ-45 to USB-C adapter (JNP-CBL-RJ45-USBC)

If you want to use RJ-45 to USB-A or RJ-45 to USB-C adapter you must have X64 (64-Bit) Virtual COM port (VCP) driver installed on your PC. See, <https://ftdichip.com/drivers/vcp-drivers/> to download the driver.

Table 107: Console Port Connector Pinouts for the PTX10008 Router

Pin	Signal	Description
1	RTS output	Request to send
2	DTR output TOD output for PTP applications	Data terminal ready Time of day for Precision Time Protocol (PTP). You can use DTR pins as a TOD universal asynchronous receiver/transmitter (UART) by using breakout cables.
3	TxD output	Transmit data
4	Signal ground	Signal ground
5	Signal ground	Signal ground
6	RxD input	Receive data

Table 107: Console Port Connector Pinouts for the PTX10008 Router (*Continued*)

Pin	Signal	Description
7	DCD input TOD output for PTP applications	Data carrier detect Time of day for PTP. You can use DCD pins as a TOD UART by using breakout cables.
8	CTS input	Clear to send

SEE ALSO

| [Connect a PTX10008 Router to a Management Console | 326](#)

USB Port Specifications for the PTX10008 Router

The following Juniper Networks USB flash drives have been tested and are officially supported for the USB port in the PTX10008 router:

- RE-USB-1G-S—1-GB USB flash drive
- RE-USB-2G-S—2-GB USB flash drive
- RE-USB-4G-S—4-GB USB flash drive



CAUTION: Any USB memory product not listed as supported for the PTX10008 router has not been tested by Juniper Networks. The use of any unsupported USB memory product could expose your device to unpredictable behavior. Juniper Networks Technical Assistance Center (JTAC) can provide only limited support for issues related to unsupported hardware. We strongly recommend that you use only supported USB flash drives.



CAUTION: Remove the USB flash drive before upgrading Junos OS or rebooting a PTX10008 Router. Failure to do so could expose your device to unpredictable behavior.

NOTE: USB flash drives used with the PTX10008 router must support USB 2.0 or later.

Management Port Connector Pinouts for the PTX10008 Router

The 1000BASE-T RJ-45 management ports use an RJ-45 connector to connect a management device for out-of-band management.

[Table 108 on page 278](#) provides the pinout information of the RJ-45 management port connector.

Table 108: RJ-45 Management Port Connector Pinouts for the PTX10008 Router

Pin	Signal	Description
1	TRP1+	Transmit/receive data pair 1
2	TRP1-	Transmit/receive data pair 1
3	TRP2+	Transmit/receive data pair 2
4	TRP3+	Transmit/receive data pair 3
5	TRP3-	Transmit/receive data pair 3
6	TRP2-	Transmit/receive data pair 2
7	TRP4+	Transmit/receive data pair 4
8	TRP4-	Transmit/receive data pair 4

4

CHAPTER

Initial Installation and Configuration for New Systems

[PTX10008 Installation Overview | 280](#)

[Unpack the PTX10008 Router | 281](#)

[Mount the PTX10008 by Using the JNP10004-RMK-4POST Rack Mount Kit | 291](#)

[Mount the PTX10008 by Using the EX-MOD-RMK-4POST Rack Mount Kit | 298](#)

[Install and Maintain the Front Door and its Components on the PTX10008 Router | 304](#)

[Connect the PTX10008 to Power | 320](#)

[Connect the PTX10008 to External Devices | 325](#)

[Perform the Initial Configuration for the PTX10008 Router | 332](#)

PTX10008 Installation Overview

The PTX10008 is a rigid sheet-metal router-chassis that houses the other hardware components such as the Routing and Control boards, Switch Interface Boards (SIBs), power supplies, fan trays, and line cards. The router chassis ships in a cardboard box that has a two-layer wooden pallet base. The router chassis is bolted to the pallet base. You can install a PTX10008 router in a standard 19-in. (483-mm) equipment rack by using the supplied rack mount kit and the flange that is attached to the chassis.

The steps to install the PTX10008 are:

1. Unpack the router following the instructions in ["Unpack the PTX10008 Shipping Pallet" on page 281](#).
2. Mount the chassis in the rack following the instructions in either ["Mount the PTX10008 by Using the JNP10004-RMK-4POST Rack Mount Kit" on page 291](#) or ["Mount the PTX10008 by Using the EX-MOD-RMK-4POST Rack Mount Kit" on page 298](#).

Because of the weight of the chassis, mounting using a mechanical lift is preferred as the easiest and safest method.

3. Install the line cards following the instructions in ["Install a PTX10008 Line Card" on page 434](#).
4. Connect the chassis to earth ground following the instructions in ["Connect the PTX10008 Router to Earth Ground" on page 320](#).
5. Connect power to the power supplies following the instructions in either ["Connect AC Power to a PTX10008" on page 322](#) or ["Connect DC Power to a PTX10008" on page 323](#).
6. Connect to the network.
 - To connect the router to a network for out-of-band management, follow instructions in ["Connect a PTX10008 Router to a Network for Out-of-Band Management" on page 325](#).
 - To connect the router to a management console, follow instructions in ["Connect a PTX10008 Router to a Management Console" on page 326](#).
7. Configure the router following the instructions in ["Perform the Initial Configuration for the PTX10008 Router" on page 332](#).
8. Install optional equipment such as the cable management system. See ["Install the PTX10008 Cable Management System" on page 439](#).

RELATED DOCUMENTATION

[PTX10008 Rack Requirements | 202](#)

[PTX10008 Clearance Requirements for Airflow and Hardware Maintenance | 205](#)

[PTX10008 Chassis Lifting Guidelines | 490](#)

Unpack the PTX10008 Router

IN THIS SECTION

- [Unpack the PTX10008 Shipping Pallet | 281](#)
- [Unpack Line Cards, Routing Control Boards, and Switch Interface Boards for the PTX10008 | 283](#)
- [Compare the PTX10008 Order to the Packing List | 285](#)
- [Register Products—Mandatory to Validate SLAs | 291](#)

To unpack the PTX10008 router and its components, read the following sections:

Unpack the PTX10008 Shipping Pallet

After you prepare the installation site as described in "[PTX10008 Site Preparation Checklist](#)" on page [197](#), you can unpack the router.

NOTE: The chassis is maximally protected inside the shipping box. Do not unpack it until you are ready to begin installation.

Ensure that you have the following parts and tools available to unpack the PTX10008:

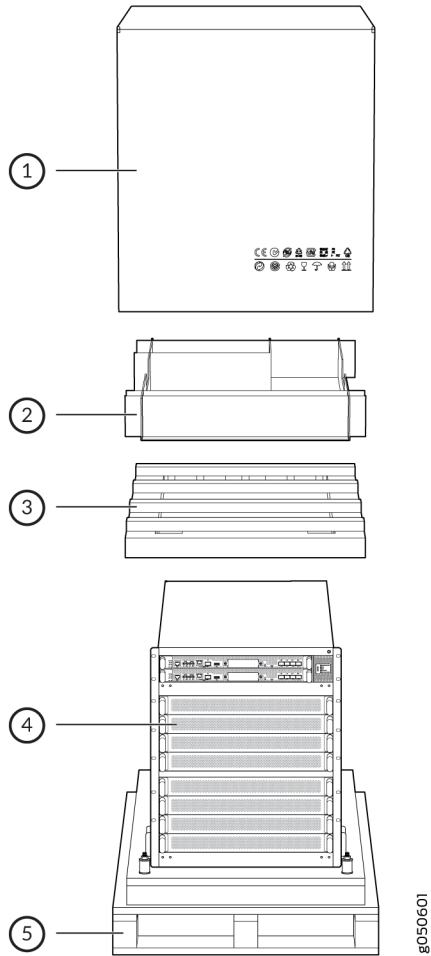
- A 13/32-in. (10-mm) open-end or socket wrench to remove the bracket bolts from the shipping pallet
- A box cutter or packing knife to slice open the nylon straps and tape that seal the crate and boxes

The chassis ships in a cardboard box that has a two-layer wooden pallet base with foam cushioning between the layers. The router chassis is bolted to the pallet base.

The shipper has the option to either ship the front panel separately or ship it along with the chassis. If the front panel arrives with the chassis, set aside the front panel box until you are ready to verify the contents of the order.

To unpack the chassis (see [Figure 87 on page 282](#)):

Figure 87: Shipping Crate and Accessory Box



1– Cardboard shipping box

4– PTX10008 chassis

2– Cardboard accessory box

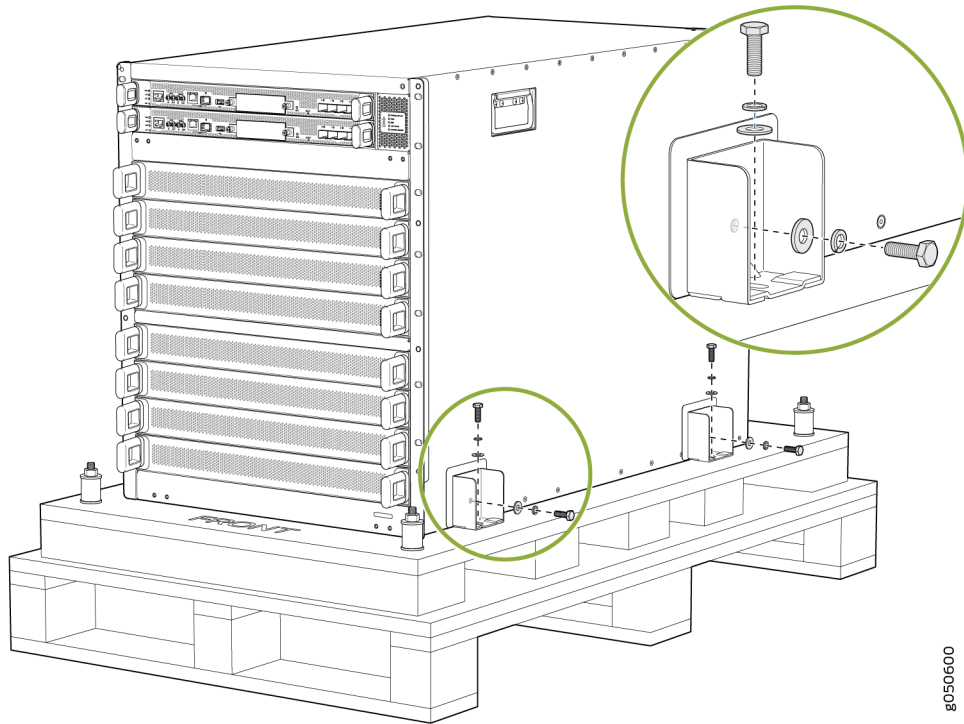
5– Wood pallet

3– Foam cover

1. Move the shipping box to a staging area as close to the installation site as possible. While the chassis is bolted to the pallet, you can use a forklift or pallet jack to move the shipping box. Make sure there is enough space to remove components from the chassis.
2. Position the shipping box with the arrows pointing up.
3. Use the box cutter to slice the nylon straps that hold the shipping box to the pallet.
4. Lift the shipping box off the chassis.
5. Remove the cardboard accessory box.
6. Remove the foam padding from the top of the box.
7. Remove the plastic cover from the router chassis.

8. Use a 13/32-in. (10-mm) open-end or socket wrench to remove the four sets of bracket bolts that secure the chassis to the shipping pallet (see [Figure 88 on page 283](#)).

Figure 88: Remove the Bracket Bolt



9. Unpack the accessory box and lay out the contents so that they are ready for use.
10. Verify that your order includes all appropriate parts. See ["Compare the PTX10008 Order to the Packing List" on page 285](#) and ["PTX10008 Configurations and Upgrade Options" on page 31](#) for information about base configurations and redundant configurations.
11. Store the brackets and bolts inside the accessory box.
12. Save the shipping box and packing materials in case you need to move or ship the router at a later time.

Unpack Line Cards, Routing Control Boards, and Switch Interface Boards for the PTX10008

Before you unpack a component:

- Ensure that you have taken the necessary precautions to prevent electrostatic discharge (ESD) damage. See *Prevention of Electrostatic Discharge Damage*.

- Ensure that you know how to handle and store the component. (See ["How to Handle and Store PTX10008 Line Cards, RCBs, and SIBs"](#) on page 420).

Line cards, additional Routing and Control Boards (RCBs), and additional Switch Interface Boards (SIBs) components are FRUs that are shipped separately from the router chassis. The housing for the RCBs and line cards are rigid sheet-metal structures that house the electronics. SIBs have an exposed printed circuit board (PCB) on one side and sheet metal on the other. All these components are shipped in a cardboard carton, secured with packing material.

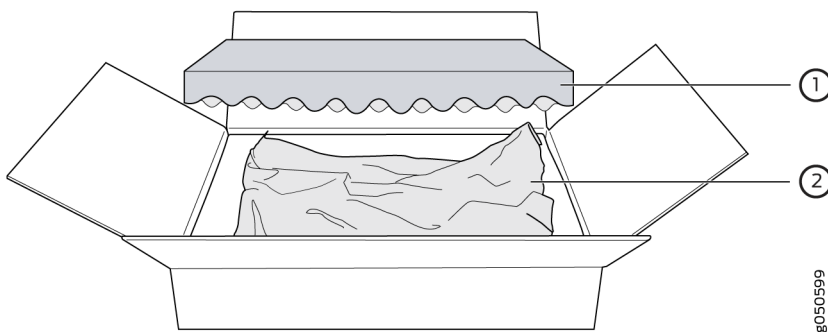


CAUTION: The components are maximally protected inside the shipping carton. Do not unpack them until you are ready to install the components in the router chassis.

To unpack an RCB, a SIB, or a line card:

1. Move the shipping carton to a staging area as close to the installation site as possible.
2. Position the carton so that the arrows are pointing up.
3. Open the top flaps on the shipping carton.
4. Pull out the packing material that holds the component in place.
5. Remove the component from the antistatic bag.
6. Save the shipping carton and packing materials in case you need to move or ship the RCB, SIB, or line card later.

Figure 89: Unpacking a Line Card



1– Foam packing material

2– Paper packaging and antistatic bag

SEE ALSO

[Install a PTX10008 Line Card | 434](#)

[Install a PTX10008 Switch Interface Board | 424](#)

[Install a PTX10008 Routing and Control Board | 343](#)

Compare the PTX10008 Order to the Packing List

The router chassis shipment includes a packing list. Check the parts you receive in the shipping crate against the items on the packing list. The packing list specifies the part number and description of each part in your order.

If any part on the packing list is missing, contact your customer service representative, or contact Juniper Networks Customer Care from within the U.S. or Canada by telephone at 1-888-314-5822. For international-dial or direct-dial options in countries without toll-free numbers, see <https://www.juniper.net/support/requesting-support.html>.

Items that ship separately from the chassis are:

- Line cards
- Chassis front door kit (JNP10008-FRNT-PNL or JNP10008-FRPNL1 with air filter)

NOTE: The kit is a spare part and can ship with the chassis or separately. The JNP10008-FRPNL1 is not available on JNP10008-SF3 switch fabric systems.

- Cable management kit (JLC-CBL-MGMT-KIT)

Use the following procedure to compare the sales order and packing list against the contents of the chassis shipping crate.

1. Determine the configuration. See "[PTX10008 Configurations and Upgrade Options](#)" on page 31. The parts shipped depend on the configuration you order. Supported configurations are:
 - Base configuration.
 - PTX10008-BASE for AC and JNP10008-SF fabric systems.
 - PTX10008-BASE for DC and JNP10008-SF fabric systems.
 - Premium redundant configuration.
 - PTX10008-PREMIUM for AC and JNP10008-SF fabric systems.
 - PTX10008-PREMIUM for DC and JNP10008-SF fabric systems.
 - PTX10008-PREM3 for AC and JNP10008-SF3 fabric systems.

- PTX10008-PREM3 for DC and JNP10008-SF3 fabric systems.

2. Compare premium redundant configuration orders using [Table 109 on page 286](#).

Table 109: Premium Redundant Configuration Order

Component	PTX10008 Quantity
Chassis, including power bus	1
Routing and Control Boards	2
Fan tray controllers <ul style="list-style-type: none"> • JNP10008-FAN-CTRL or • JNP10008-FTC2 	2
Fan trays <ul style="list-style-type: none"> • JNP10008-FAN or • JNP10008-FAN2 	2
Power supplies <ul style="list-style-type: none"> • JNP10K-PWR-AC • JNP10K-PWR-AC2 • JNP10K-PWR-DC • JNP10K-PWR-DC2 	6
Switch Interface Boards (SIBs)	6
Covers in the line-card positions	8
Accessory kit (see Table 111 on page 288)	1
Rack mount kit (see Table 112 on page 289)	1

Table 109: Premium Redundant Configuration Order (Continued)

Component	PTX10008 Quantity
Front door kit (see Table 113 on page 290 or Table 114 on page 290)	1
Documentation Roadmap Card	1

3. Compare base configuration orders using [Table 110 on page 287](#).

Table 110: Base Configuration Order

Component	PTX10008 Quantity
Chassis, including power bus	1
RCBs	1
Cover panel, in the RCB slot	1
Fan tray controllers	2
Fan trays	2
Power supplies	3
SIBs	5
Cover in a SIB position	1
Covers in the power-supply positions	3
Covers in the line-card positions	8
Dust covers for RCB ports	5 for RE0; 3 for RE1

Table 110: Base Configuration Order (Continued)

Component	PTX10008 Quantity
Accessory kit (see Table 111 on page 288)	1
Rack mount kit (see Table 112 on page 289)	1
Front door kit, lockable (see Table 113 on page 290 or Table 114 on page 290)	1
Documentation Roadmap Card	1

4. Compare the contents of the accessory kit with [Table 111 on page 288](#).

Table 111: PTX10008 Accessory Kit

Component	Quantity	
	AC Configurations	DC Configurations
Warranty card	1	1
End User License Agreement (EULA)	1	1
Electrostatic discharge (ESD) wrist strap with cable	1	1
Media kit (flash drives, PCMCIA card adapter)	1	1
Chassis ground lug, 2-hole, 10-32, 4 AWG	1	1
Power cord retainer clips	Premium = 12 Base = 6	-
DC terminal lugs, 2-hole, 10-32, 4 AWG	-	Premium = 24 Base = 12

Table 111: PTX10008 Accessory Kit (Continued)

Component	Quantity	
	AC Configurations	DC Configurations
Antistatic bags	2	

NOTE: We no longer include the RJ-45 console cable with the DB-9 adapter as part of the device package. If the console cable and adapter are not included in your device package, or if you need a different type of adapter, you can order the following separately:

- RJ-45 to DB-9 adapter (JNP-CBL-RJ45-DB9)
- RJ-45 to USB-A adapter (JNP-CBL-RJ45-USBA)
- RJ-45 to USB-C adapter (JNP-CBL-RJ45-USBC)

If you want to use RJ-45 to USB-A or RJ-45 to USB-C adapter you must have X64 (64-Bit) Virtual COM port (VCP) driver installed on your PC. See, <https://ftdichip.com/drivers/vcp-drivers/> to download the driver.

5. Compare the contents of the rack mount kit with [Table 112 on page 289](#).

Table 112: PTX10008 Rack Mount Kit

Component	Quantity
Mounting tray	1
Mounting blades	2
Safety restraint	1
Phillips flat-head screws, 8-32 x .375 in.	12

6. Compare the contents of JNP10008-FRPNL1 (with air filter) front panel kit with [Table 113 on page 290](#), or JNP10008-FRNT-PNL (without air filter) front panel kit with [Table 114 on page 290](#).

Table 113: PTX10008 JNP10008-FRPNL1 Front Panel Kit

Component	Quantity
Front panel	1
Left baffle	1
Right baffle	1
Latch bracket set (two interchangeable latch brackets, one right base bracket, and one left base bracket)	1
Cable seal set (two seals for the right side and one seal for the left side)	1
Phillips flat-head screws	8
Documentation Roadmap Card	1

Table 114: PTX10008 JNP10008-FRNT-PNL Front Panel Kit

Component	Quantity
Front panel	1
Side baffles (interchangeable)	2
Latch bracket set (two interchangeable latch brackets, one right base bracket, and one left base bracket)	1
Phillips flat-head screws	8
Documentation Roadmap Card	1

SEE ALSO

| [PTX10008 Configurations and Upgrade Options](#) | 31

Register Products—Mandatory to Validate SLAs

Register all new Juniper Networks hardware products and changes to an existing installed product using the Juniper Networks website to activate your hardware replacement service-level agreements (SLAs).



CAUTION: Register product serial numbers on the Juniper Networks website. Update the installation base data if any addition or change to the installation base occurs or if the installation base is moved. Juniper Networks is not responsible for not meeting the hardware replacement SLA for products that do not have registered serial numbers or accurate installation base data.

Register your product(s) at <https://tools.juniper.net/svcreg/SRegSerialNum.jsp>.

Update your installation base at <https://www.juniper.net/customers/csc/management/updateinstallbase.jsp>.

Mount the PTX10008 by Using the JNP10004-RMK-4POST Rack Mount Kit

You can mount a PTX10008 router in a four-post closed frame rack or a four-post open frame rack by using a rack mount kit. The rack mount kit with the part number JNP10004-RMK-4POST is shipped by default. You can order the rack mount kit with the part number EX-MOD-RMK-4POST separately. In this topic, we describe how to mount the router by using the JNP10004-RMK-4POST rack mount kit.

The router chassis weighs approximately 145 lb (66 kg) with only the fan tray controllers installed.

You can mount a PTX10008 manually or by using a mechanical lift. Because of the router's size and weight, we strongly recommend that you use a mechanical lift to mount the PTX10008.

If you are mounting the router by using a lift, ensure that you have a mechanical lift rated for 500 lb (226.8 kg).

If you are mounting the router manually, ensure that there are at least three people to lift the chassis.

Before you mount the PTX10008 router:

- Prepare the site for installation as described in "[PTX10008 Site Preparation Checklist](#)" on page 197.
- Unpack the router as described in "[Unpack the PTX10008 Shipping Pallet](#)" on page 281.
- Review the chassis lifting guidelines in "[PTX10008 Chassis Lifting Guidelines](#)" on page 490.

Ensure that you have the following parts and tools available:

- 34 rack mount screws appropriate for your rack to secure the mounting blades, mounting tray, chassis, and safety restraint to the rack (not provided)
- A Phillips (+) screwdriver, number 1, 2, or 3, depending on the size of your rack mount screws (not provided)

The rack mount kit consists of the following components:

- One mounting tray
- Two mounting blades
- One safety restraint
- 12 Phillips 8-32 x .375 flat-head screws



CAUTION: Install line cards and other components in the chassis only after you mount the chassis securely.



CAUTION: Before mounting the router on a rack, have a qualified technician verify that the rack is strong enough to support the router's weight and is adequately supported at the installation site.

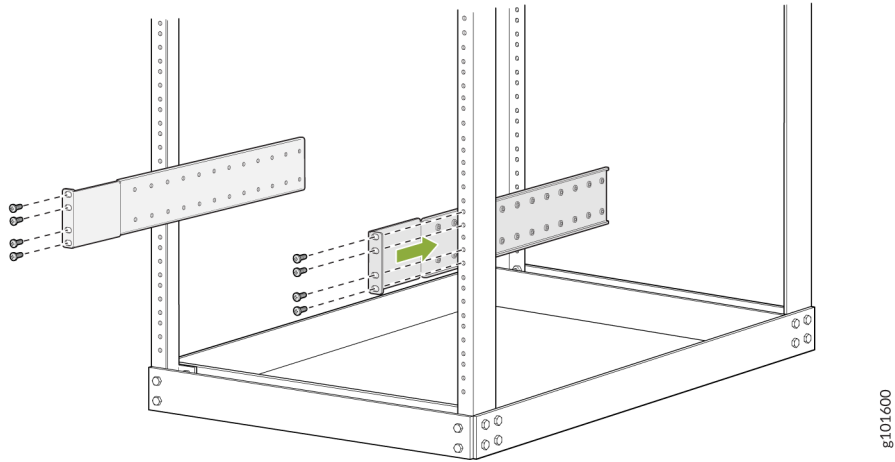


CAUTION: If you are mounting multiple units on a rack, plan to mount the first router at the bottom of the rack. Mount the heaviest unit at the bottom of the rack and mount the other units from the bottom of the rack to the top in decreasing order of the weight of the units.

To mount the router:

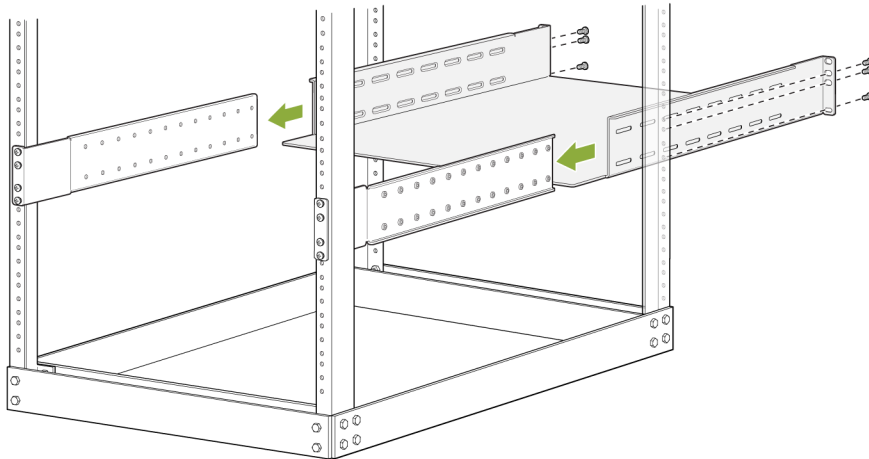
1. Wrap and fasten one end of the ESD grounding strap around your bare wrist, and connect the other end to a site ESD point.
2. Attach the mounting blades to the front rack posts by using eight rack mount screws appropriate for your rack and a screwdriver (see [Figure 90 on page 293](#)).

Figure 90: Attach the Mounting Blades



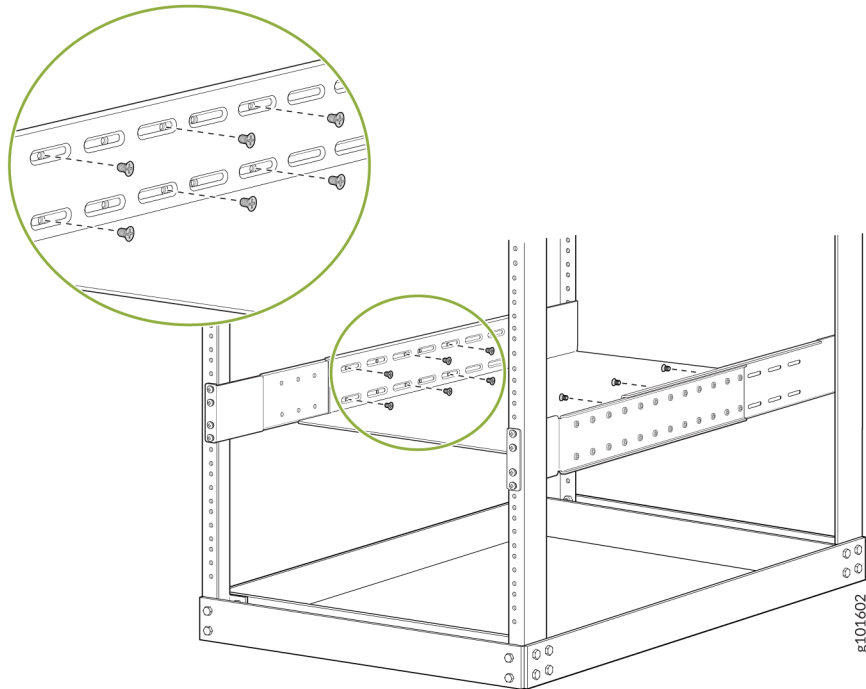
3. From the rear of the rack, slide the mounting tray into the rear posts of the rack such that the mounting blades slide into the grooves on the mounting tray. Attach the tray to the rear rack posts by using six rack mount screws appropriate for your rack and a screwdriver (see [Figure 91 on page 293](#)).

Figure 91: Attach the Mounting Tray



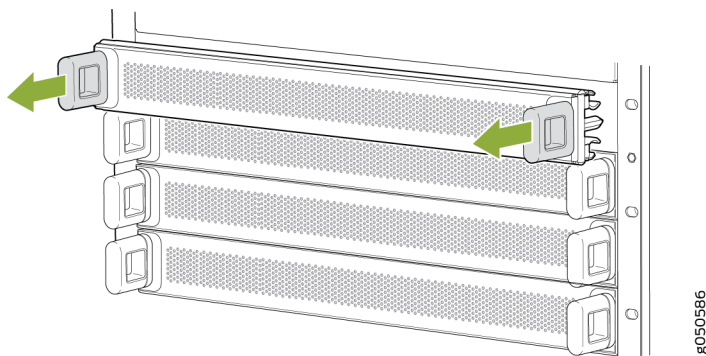
4. Check that the mounting tray is level.
5. Attach the mounting blades to the tray with the 12 Phillips 8-32 x .375 in. flat-head screws (see [Figure 92 on page 294](#)).

Figure 92: Attach the Mounting Blades to the Mounting Tray



6. Remove the line card slot covers by grasping the handles and pulling the covers straight out (see [Figure 93 on page 294](#)). Store the covers.

Figure 93: Remove the Line Card Slot Covers



7. If you are mounting the router by using a lift:
 - a. Load the router onto the lift, making sure it rests securely on the lift platform (see [Figure 94 on page 295](#)).

Figure 94: Load the PTX10008 onto a Mechanical Lift



- b. By using the lift, align the router in front of the rack, centering it in front of the mounting tray.
- c. Lift the chassis approximately 0.75 in. (1.9 cm) above the surface of the mounting tray. Align the chassis as close as possible to the mounting tray.

If you are mounting the router manually:

- a. Align the router in front of the rack, centering it in front of the mounting tray. Use a pallet jack if one is available.



WARNING: To prevent injury, keep your back straight and lift with your legs, not your back. Do not twist your body as you lift. Balance the load evenly and be sure that your footing is firm.

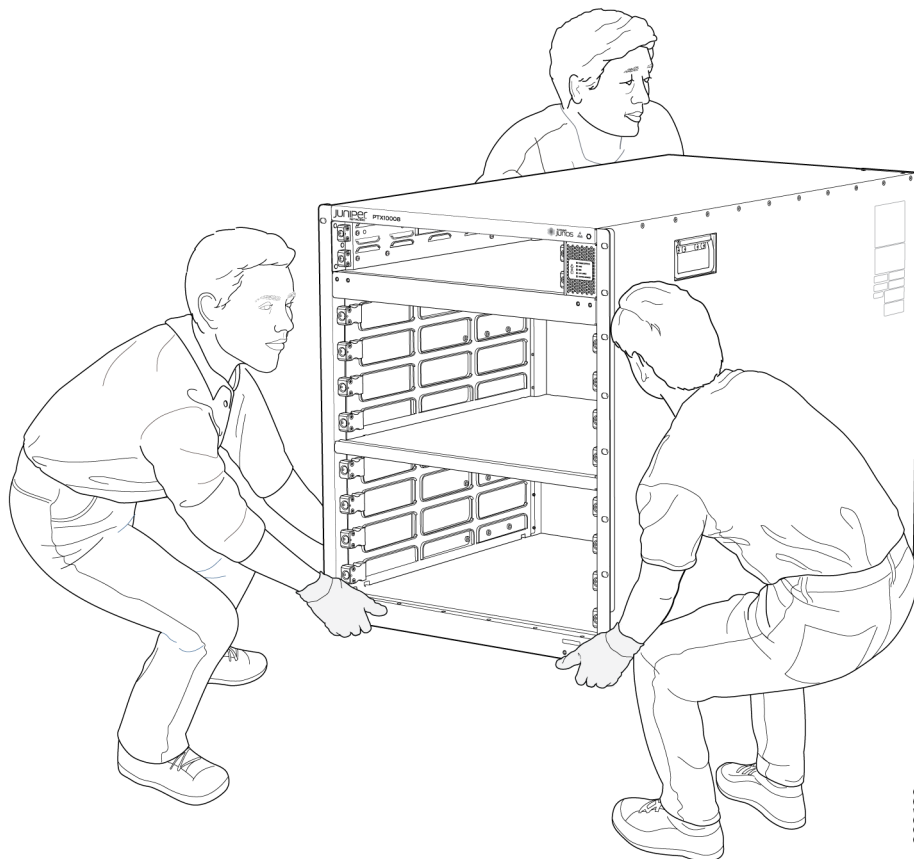


CAUTION: If you are mounting more than one router, mount the first one at the bottom of the rack. Do not attempt to mount a router manually in an upper position in a rack.

NOTE: The chassis has two handles that are designed for subtle positioning of the chassis. Do not lift the chassis by the handles.

- b. With one person on each side and one person in the rear, hold the bottom of the chassis and carefully lift it onto the mounting tray (see [Figure 95 on page 296](#)).

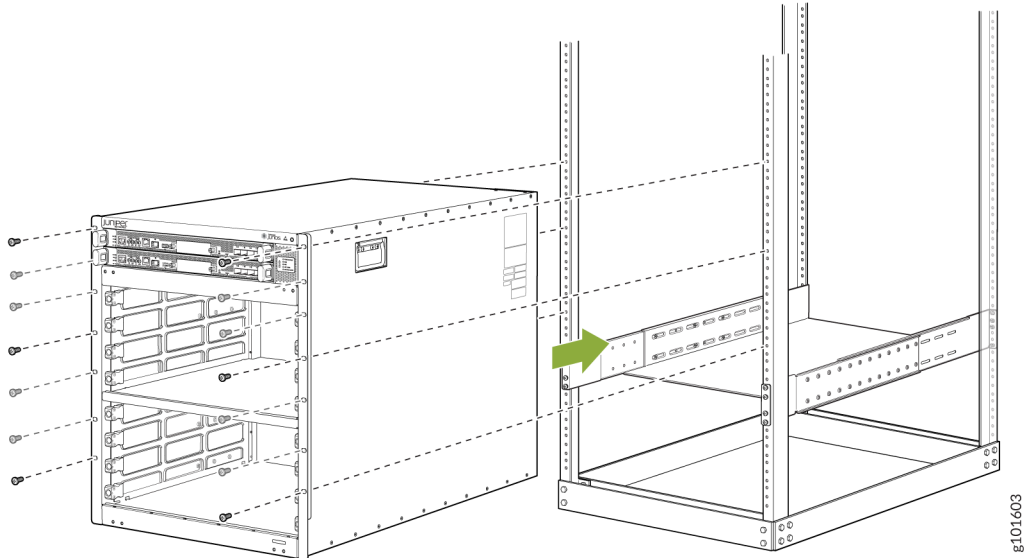
Figure 95: Lift the PTX10008 Manually



8. Carefully slide the chassis onto the mounting tray until the chassis flanges contact the rack rails. The mounting blades ensure that the holes in the chassis flanges line up with the holes in the rack rails.

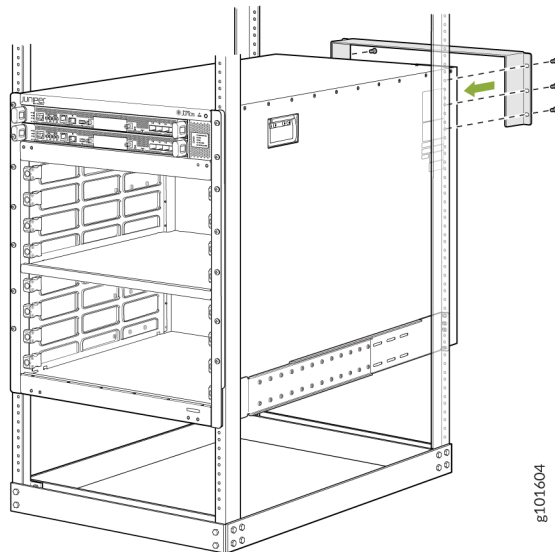
9. Attach the chassis to the rack by installing 14 rack mount screws through each open flange hole and rack hole (see [Figure 96 on page 297](#)).

Figure 96: Attach the Chassis to the Rack



10. If you used a lift to mount the router, move the lift away from the rack.
11. Check the alignment of the router. The rack mount screws on each side of the rack should line up, and the router should be level. Tighten the screws.
12. Insert the safety restraint between the rear posts of the rack. It should rest on the top of the chassis and align with the holes in the rack.
13. Attach the restraint to the rack by installing six rack mount screws through each open flange hole and rack hole (see [Figure 97 on page 298](#)). Tighten the screws.

Figure 97: Attach the Safety Restraint



Mount the PTX10008 by Using the EX-MOD-RMK-4POST Rack Mount Kit

You can mount a PTX10008 router in a four-post closed frame rack or a four-post open frame rack by using a rack mount kit. The rack mount kit with the part number JNP10004-RMK-4POST is shipped by default. You can order the rack mount kit with the part number EX-MOD-RMK-4POST separately. In this topic, we describe how to mount the router by using the EX-MOD-RMK-4POST rack mount kit.

The router chassis weighs approximately 145 lb (66 kg) with only the fan tray controllers installed.

You can mount a PTX10008 manually or by using a mechanical lift. Because of the router's size and weight, we strongly recommend that you use a mechanical lift to mount the PTX10008.

If you are mounting the router by using a lift, ensure that you have a mechanical lift rated for 500 lb (226.8 kg).

If you are mounting the router manually, ensure that there are at least three people to lift the chassis.

Before you mount the PTX10008 router:

- Prepare the site for installation as described in "[PTX10008 Site Preparation Checklist](#)" on page 197.
- Unpack the router as described in "[Unpack the PTX10008 Shipping Pallet](#)" on page 281.

- Review the chassis lifting guidelines in "[PTX10008 Chassis Lifting Guidelines](#)" on page 490.

Ensure that you have the following parts and tools available:

- 16 rack mount screws appropriate for your rack to secure the mounting brackets to the rack (not provided)
- 14 rack mount screws appropriate for your rack to secure the chassis to the rack (not provided)
- A Phillips (+) screwdriver, number 1, 2, or 3, depending on the size of your rack screws (not provided)
- A Phillips (+) screwdriver, number 2, to install the screws that connect the rear and base brackets (not provided)

The rack mount kit consists of the following components:

- One left base bracket. The bracket is labeled **LEFT FRONT** on the side of the bracket that faces the interior of the rack, near the holes for attaching the bracket to the rack.
- One right base bracket. The bracket is labeled **RIGHT FRONT** on the side of the bracket that faces the interior of the rack, near the holes for attaching the bracket to the rack.
- Two rear brackets. These brackets are labeled **REAR** on the side of the bracket that faces the interior of the rack, near the holes for attaching the bracket to the rack. The rear brackets are interchangeable; you can use either of the rear brackets with the right or left base bracket.
- 12 Phillips flat-head screws



CAUTION: Install line cards and other components in the chassis only after you mount the chassis securely.



CAUTION: Before mounting the router on a rack, have a qualified technician verify that the rack is strong enough to support the router's weight and is adequately supported at the installation site.



CAUTION: If you are mounting multiple units on a rack, plan to mount the first router at the bottom of the rack. Mount the heaviest unit at the bottom of the rack and mount the other units from the bottom of the rack to the top in decreasing order of the weight of the units.

To mount the router:

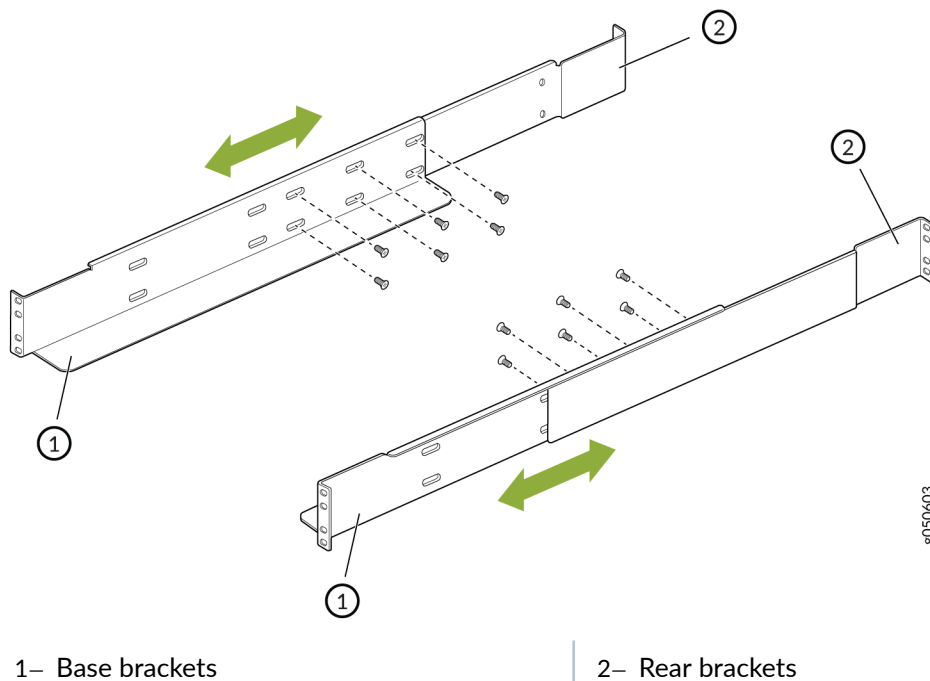
1. Wrap and fasten one end of the ESD grounding strap around your bare wrist, and connect the other end to a site ESD point.

2. Line up the left base bracket in the left side of the rack so that its front screw holes line up with the holes in the rack. Use four mounting screws appropriate for your rack to secure the left base bracket to the rack.
3. Line up one of the rear brackets at the left rear of the rack on the same level as the left base bracket, so that the rear bracket overlaps with the left base bracket. The screw holes for connecting the base and rear brackets should overlap. Use four mounting screws appropriate for your rack to secure the rear bracket to the rack.

NOTE: When you install the base and rear brackets, the adjustable portion of the brackets overlap. Use the overlap area to adjust the total bracket length to fit any of the four standard rack sizes: 19 in. (483 mm), 23.62 in. (600 mm), 30 in. (762 mm), or 31.5 in. (800 mm).

4. Attach the left base and rear brackets (see [Figure 98 on page 300](#)):
 - a. Insert six of the flat-head screws provided with the mounting brackets into the overlapping bracket holes.
 - b. Tighten the screws by using a number 2 Phillips screwdriver.

Figure 98: Attach the Base and Rear Brackets

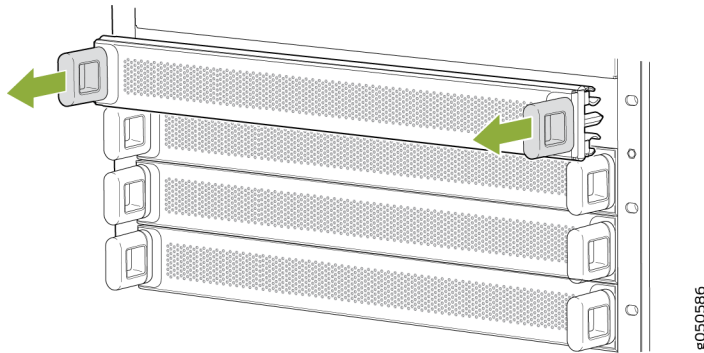


5. Repeat the instructions in Step 2 through Step 4 to install the right base and rear brackets.

NOTE: Make sure that the left and right brackets are on the same level; if they are not, the chassis will rest at an angle.

6. Remove the line card slot covers by grasping the handles and pulling the covers straight out (see [Figure 99 on page 301](#)). Store the covers.

Figure 99: Remove the Line Card Slot Covers



7. If you are mounting the router by using a lift:
 - a. Load the router onto the lift, making sure it rests securely on the lift platform (see [Figure 100 on page 302](#)).

Figure 100: Load the PTX10008 onto a Mechanical Lift



- b. By using the lift, align the router in front of the rack, centering it in front of the base brackets.
- c. Lift the chassis approximately 0.75 in. (1.9 cm) above the surface of the base brackets. Align the chassis as close as possible to the base brackets.

If you are mounting the router manually:

- a. Align the router in front of the rack, centering it in front of the base brackets. Use a pallet jack if one is available.



WARNING: To prevent injury, keep your back straight and lift with your legs, not your back. Do not twist your body as you lift. Balance the load evenly and be sure that your footing is firm.

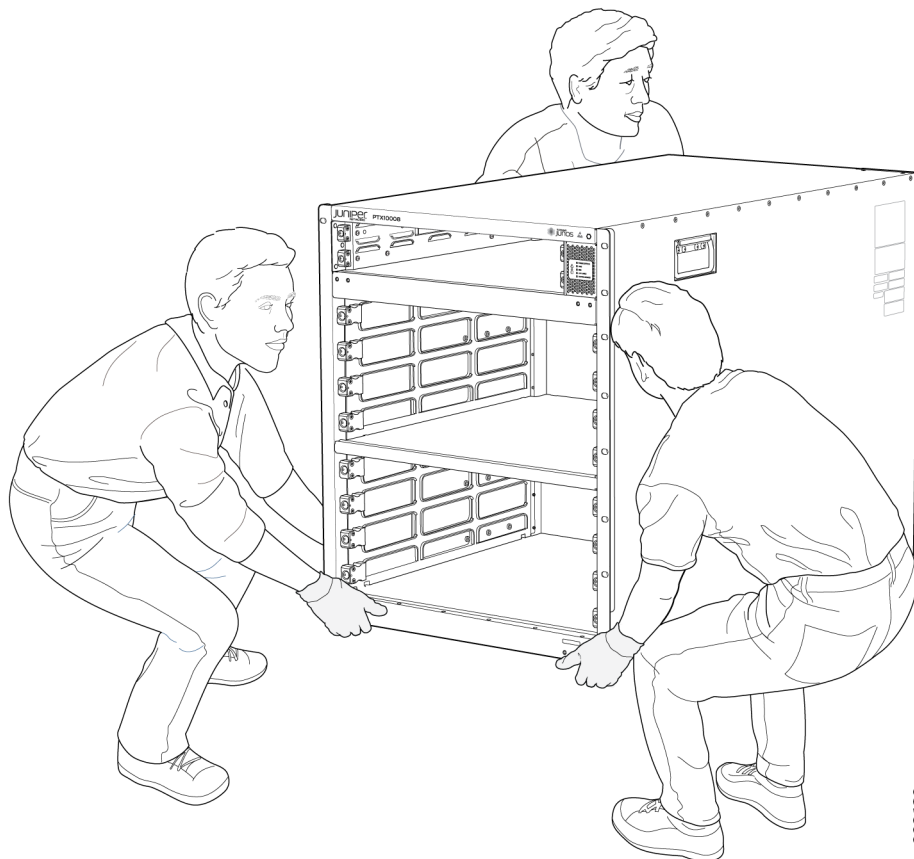


CAUTION: If you are mounting more than one router, mount the first one at the bottom of the rack. Do not attempt to mount a router manually in an upper position in a rack.

NOTE: The chassis has two handles that are designed for subtle positioning of the chassis. Do not lift the chassis by the handles.

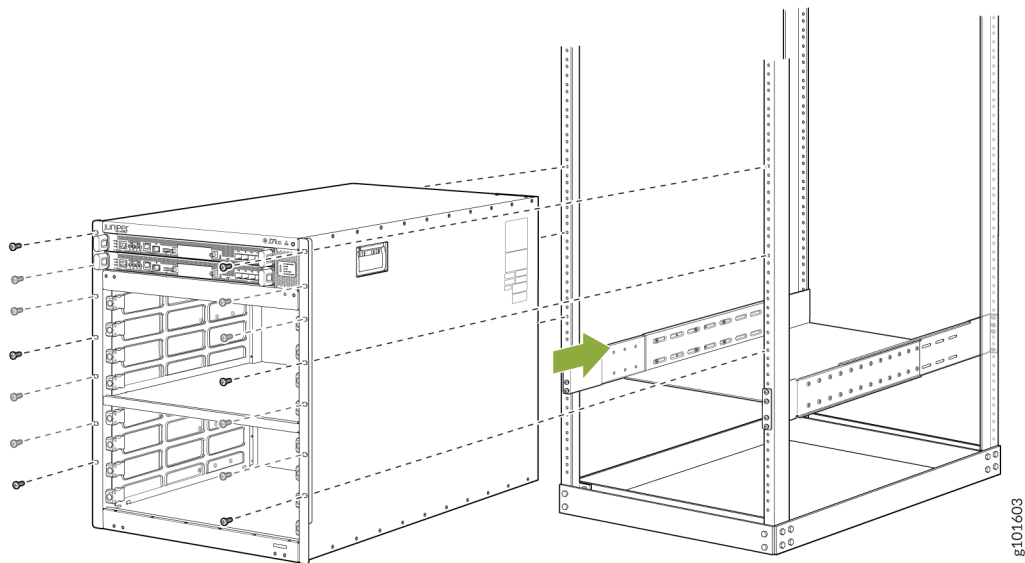
- b. With one person on each side and one person in the rear, hold the bottom of the chassis and carefully lift it onto the base brackets (see [Figure 101 on page 303](#)).

Figure 101: Lift the PTX10008 Manually



8. Carefully slide the chassis onto the adjustable base and rear brackets until the chassis flanges contact the rack rails (see [Figure 102 on page 304](#)). The base and rear brackets ensure that the holes in the chassis flanges line up with the holes in the rack rails.

Figure 102: Attach the Chassis to the Rack



9. Move the lift away from the rack.
10. Attach the chassis to the rack by installing a rack mount screw appropriate for your rack through each open flange hole and rack hole, starting from the bottom.
11. Visually inspect the alignment of the router. If the router is installed properly in the rack, all the rack mount screws on one side of the rack are aligned with the rack mount screws on the other side and the router is level.
12. After ensuring that the router is aligned properly, tighten the screws.
13. After you install the rack mount screws and securely bolt the chassis to the rack, install the components in the chassis.

Install and Maintain the Front Door and its Components on the PTX10008 Router

IN THIS SECTION

- [Install the Front Door on the PTX10008 Router | 305](#)
- [Install the Air Filter in the JNP10008-FRPNL1 Front Door | 312](#)

- [Remove the Air Filter from the JNP10008-FRPNL1 Front Door | 314](#)
- [Remove the Side EMI Deflectors from the Front Door | 318](#)
- [Remove the Front Door from the PTX10008 Router | 318](#)

The front door is required on the PTX10008 to protect fiber-optic cabling and to provide additional protection from electromagnetic interference (EMI). You can install the front door with or without the optional cable management system.

The PTX10008 supports two types of front doors:

1. The door with the part number JNP10008-FRNT-PNL that supports side EMI deflectors.
2. The door with the part number JNP10008-FRPNL1 that supports side EMI deflectors, an air filter.

Install the Front Door on the PTX10008 Router

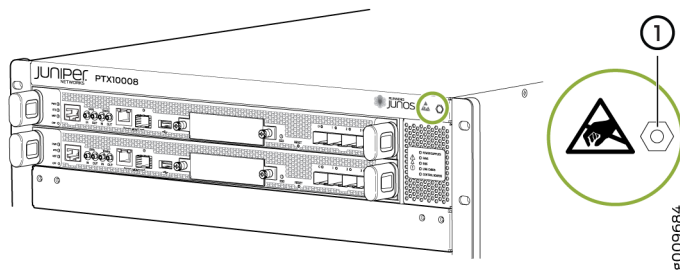
Before you install the front door, ensure that you have the following tools and parts available:

- A Phillips (+) screwdriver, number 2
- Front door and side EMI deflectors (provided in the front door kit)
- Base bracket set (two base brackets—one right base bracket and one left base bracket; provided)
- Latch bracket set (two latch brackets—one right latch bracket and one left latch bracket; provided)
- Eight Phillips flat-head mounting screws (provided in the front door kit)
- An Electrostatic discharge (ESD) grounding strap (provided in the accessory kit)
- (For JNP10008-FRPNL1) Three cable seals—Two cable seals for the right side and one cable seal for the left side (provided in the front door kit)
- (For JNP10008-FRPNL1) Air filter (provided in the front door kit)

To install the front door:

1. Wrap and fasten one end of the ESD grounding strap around your bare wrist and connect the other end of the strap to the ESD point on the front of the chassis. See [Figure 103 on page 306](#).

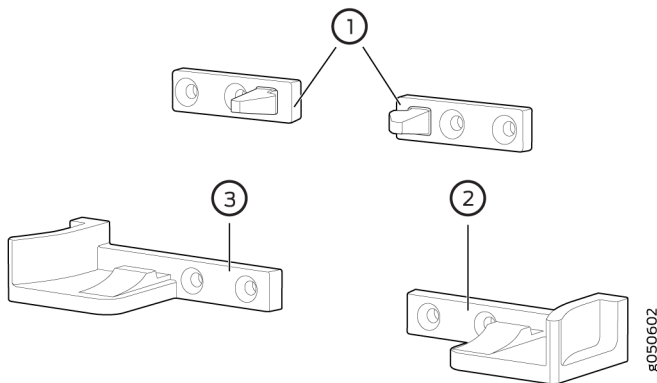
Figure 103: ESD Point on the Front of the Chassis



1– ESD point

2. Remove the plastic bag that is taped to the front door. This bag holds the latch brackets, base brackets, and screws. See [Figure 104 on page 306](#). The base brackets are larger than the latch brackets.

Figure 104: Front Door Mounting Brackets



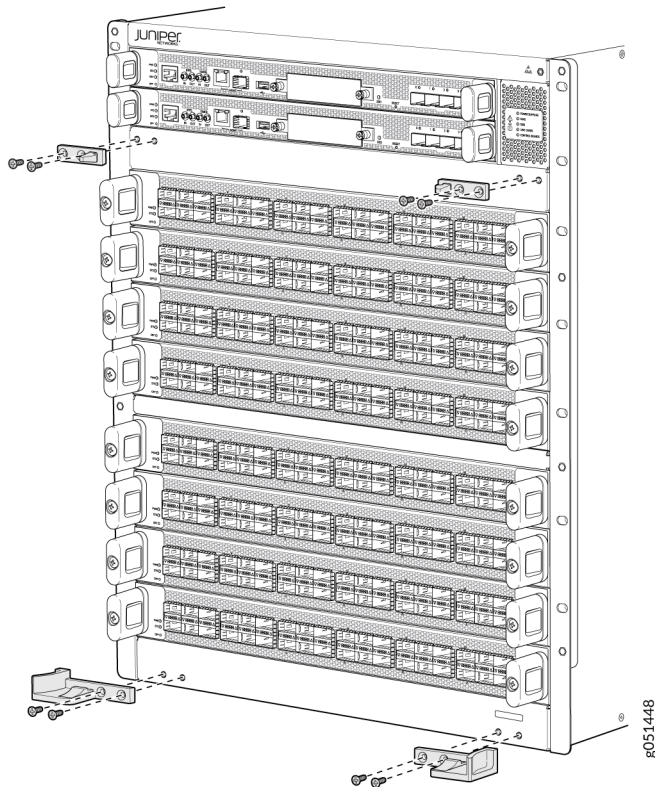
1– Latch brackets

3– Left base bracket

2– Right base bracket

3. Attach the right and left base brackets to the bottom front of the chassis. Attach the two latch brackets to the chassis. Screw holes are located for each latch bracket between the top line card slot and the Routing and Control Boards (RCBs). Use the Phillips screwdriver to attach the base brackets to the lower front of the chassis using four of the supplied flat-head screws. See [Figure 105 on page 307](#).

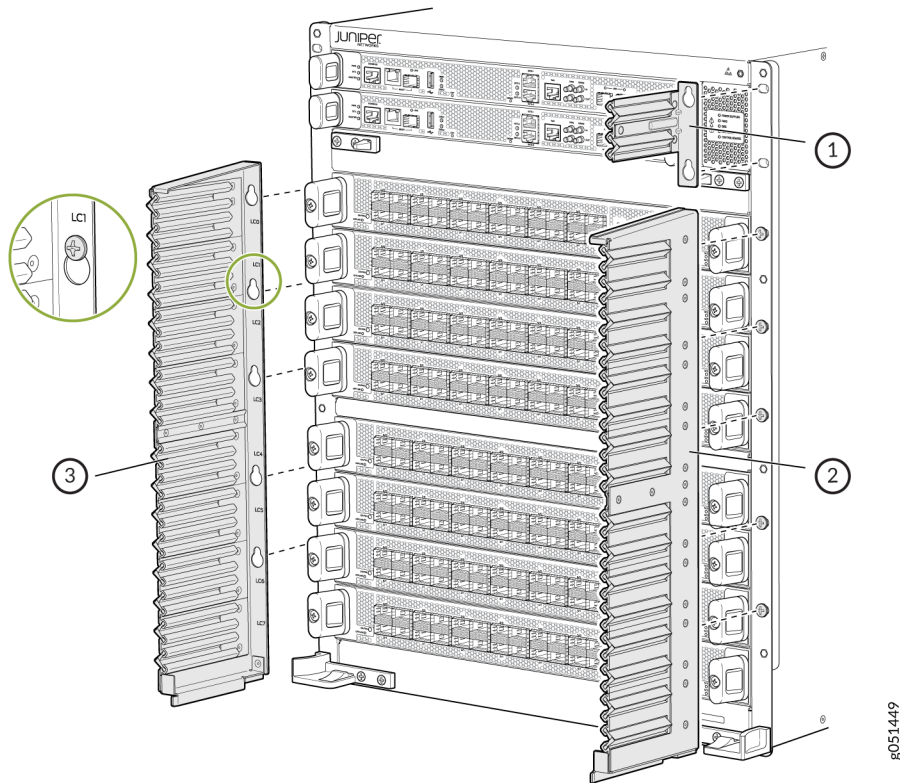
Figure 105: Attach Base and Latch Brackets



4. Install the cable seals.

- a. Remove the top right mounting screw next to the RCB by using the Phillips screwdriver. The mounting screws attach the chassis flanges to the 4-post rack.
- b. Align the hole of the RCB cable seal over the mounting hole in the flange. Fasten the cable seal and flange to the rack by using the Phillips screwdriver to tighten the mounting screw.
- c. Loosen the five mounting screws next to the line card slots along one side of the chassis.
- d. Position the keyhole slots of one of the long cable seals over the mounting screws. The long cable seals are not interchangeable; there is a right cable seal and a left cable seal. Install the cable seals so that the keyhole slots are on the inside, next to the line card. See [Figure 106 on page 308](#).

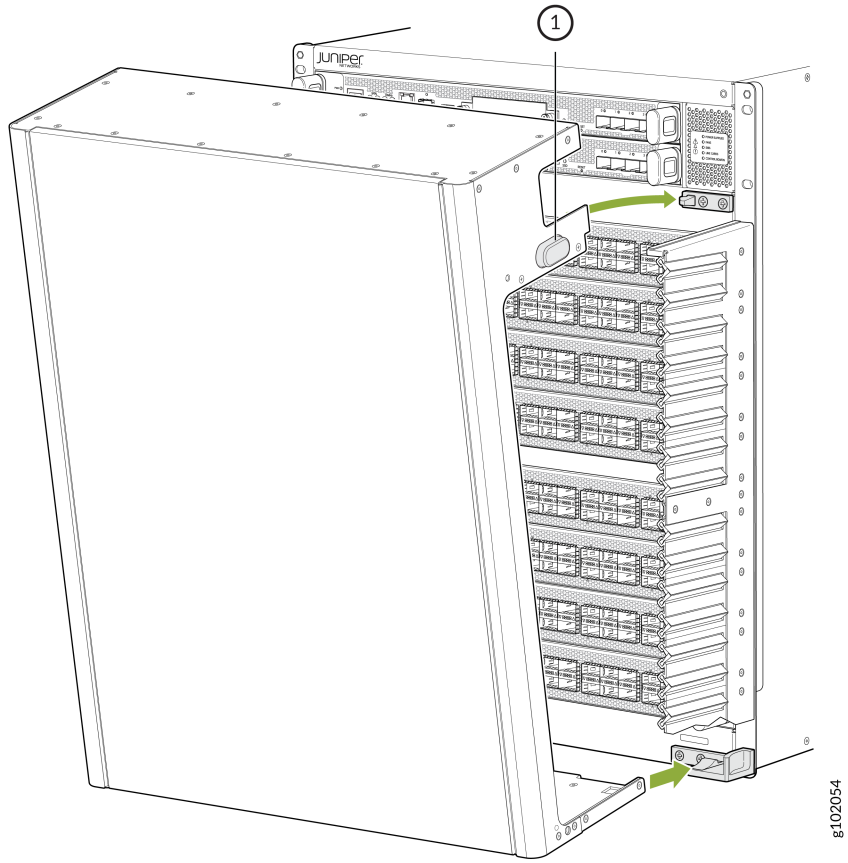
Figure 106: Install the Cable Seals



1– RCB cable seal, install on the right of the RCB	3– Left cable seal
2– Right cable seal	

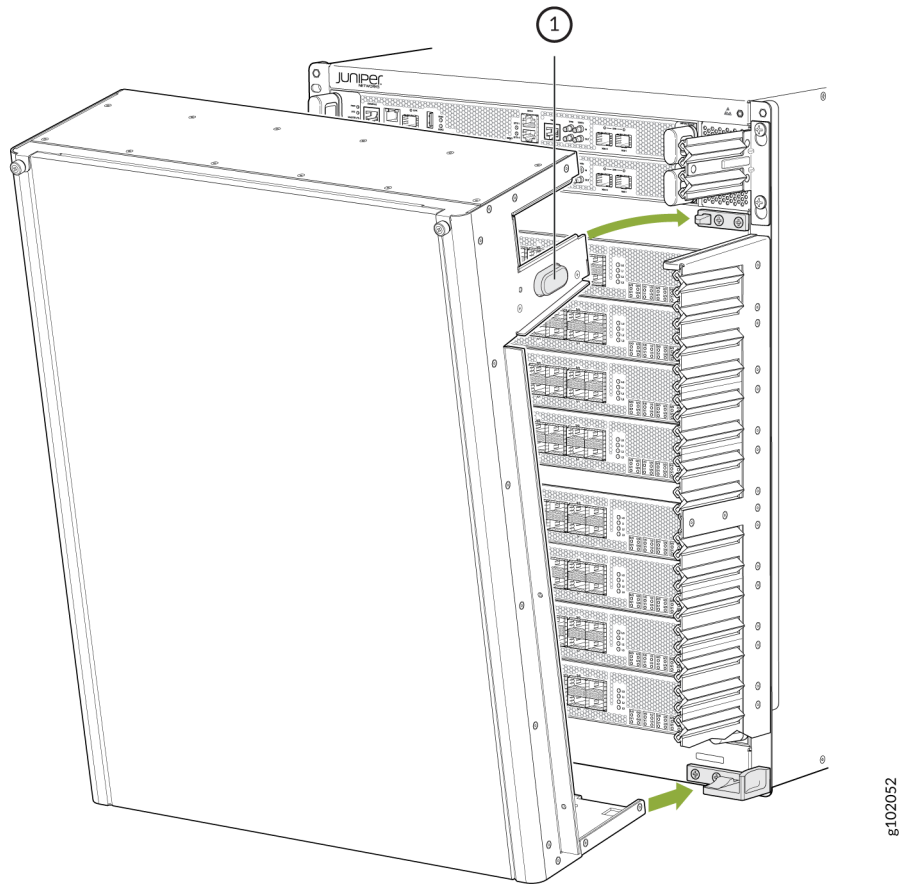
- e. Slide the keyhole slot down behind the mounting screws and align the cable seals with the chassis. Tighten the mounting screw with a Phillips screwdriver.
- f. Repeat Step 4.c through Step 4.e for the other cable seal.
5. If you have not yet installed the line cards, or the optional cable management system, do that now before attaching the door. See ["Install a PTX10008 Line Card" on page 434](#) and ["Install the PTX10008 Cable Management System" on page 439](#).
6. Lift the front door and rest it on the two base brackets.
7. Slide the door on the bracket guides until it engages on the two ramps.
8. Tilt the door toward the chassis until it is vertical with the chassis. The release buttons on the side of the door allow the door to latch into place. See [Figure 107 on page 309](#) for JNP10008-FRNT-PNL front door or [Figure 108 on page 310](#) for JNP10008-FRPNL1 front door.

Figure 107: Attach the JNP10008-FRNT-PNL Front Door



1- Release button

Figure 108: Attach the JNP10008-FRPNL1 Front Door



1– Release button

9. Install the side EMI deflectors.

NOTE: There are mounting points to attach the side EMI deflectors on JNP10008-FRNT-PNL and three mounting points to attach the side EMI deflectors on JNP10008-FRPNL1.

- a. Align the knobs of the right side EMI deflector over the mounting holes on the right side of the front door. Turn the knobs clockwise to fasten the side EMI deflector to the front door. See [Figure 109 on page 311](#) for JNP10008-FRNT-PNL or [Figure 110 on page 312](#) for JNP10008-FRPNL1.
- b. Repeat the step to install the other side EMI deflector on the left side of the front door.

Figure 109: Install the Side EMI Deflectors on JNP10008-FRNT-PNL

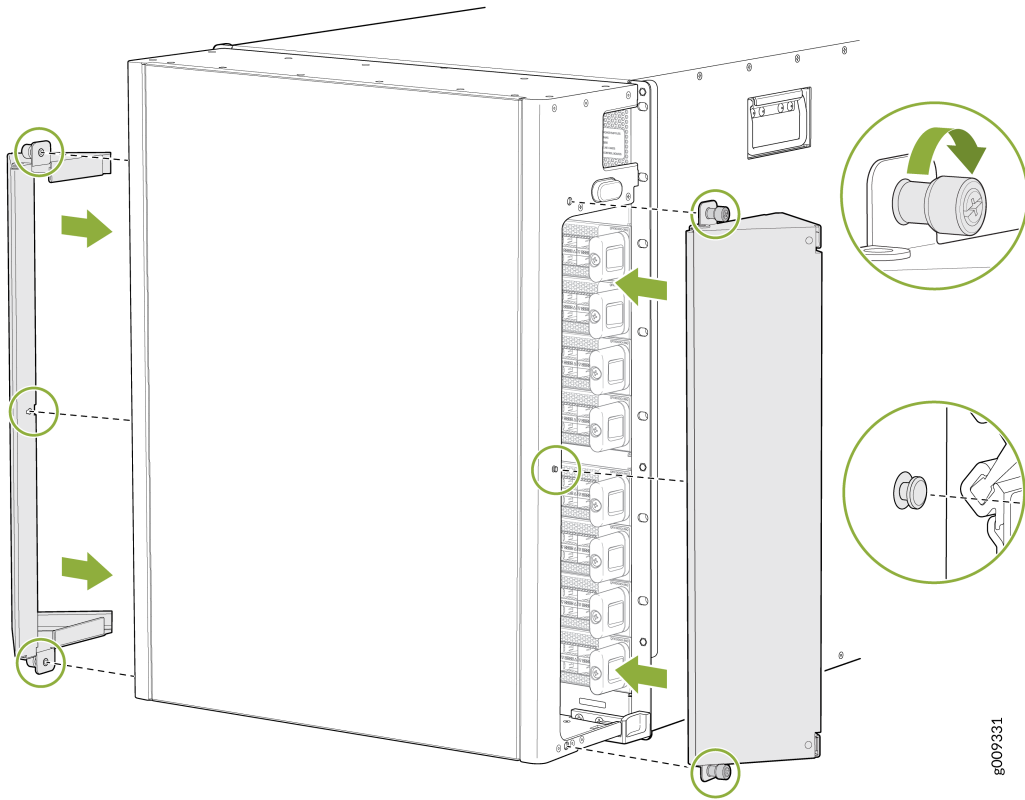
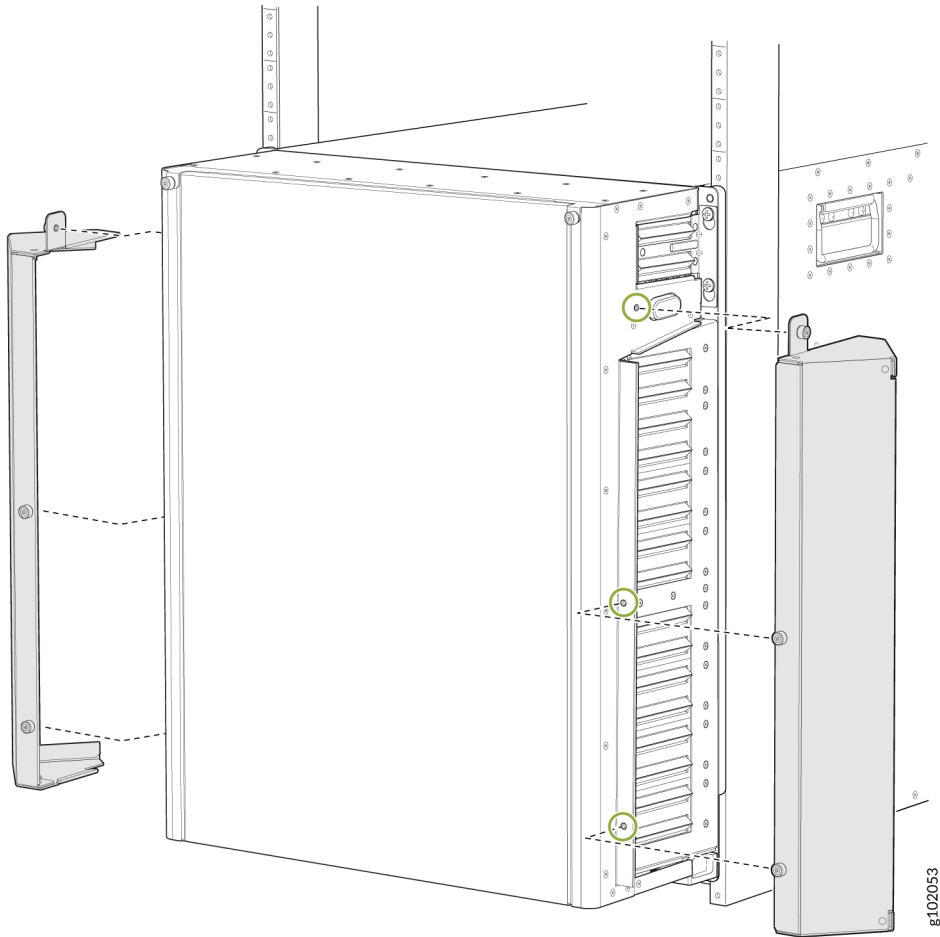


Figure 110: Install the Side EMI Deflectors on JNP10008-FRPNL1



Install the Air Filter in the JNP10008-FRPNL1 Front Door

The JNP10008-FRPNL1 front door supports an air filter to keep the dust away from the chassis. You must replace the air filter every 6 months.

NOTE: The maximum supported temperature for normal operation must be lower by 3° C when the air filter is new and lower by 6° C when the air filter is at the end of its life.

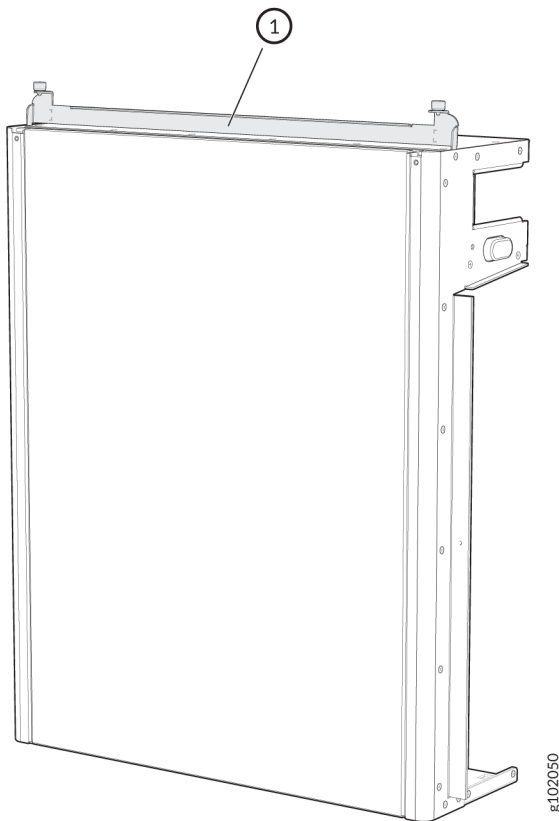
Before you install the air filter on the front door:

- Ensure that you have followed all safety warnings and cautions.
- Ensure you understand how to prevent ESD damage. See ["Prevention of Electrostatic Discharge Damage" on page 509](#).
- Ensure that you have the following parts and tools available:
 - An ESD grounding strap (provided in the accessory kit)
 - Phillips (+) screwdriver, number 2

To install the air filter:

1. Wrap and fasten one end of the ESD grounding strap around your bare wrist and connect the other end of the strap to the ESD point on the front of the chassis. See [Figure 103 on page 306](#).
2. Turn the thumbscrews of the air filter frame anti-clockwise and flip the air filter frame over to expose the air filter slot. See [Figure 111 on page 313](#).

Figure 111: Air Filter Slot in the JNP10008-FRPNL1 Front Door



8102050

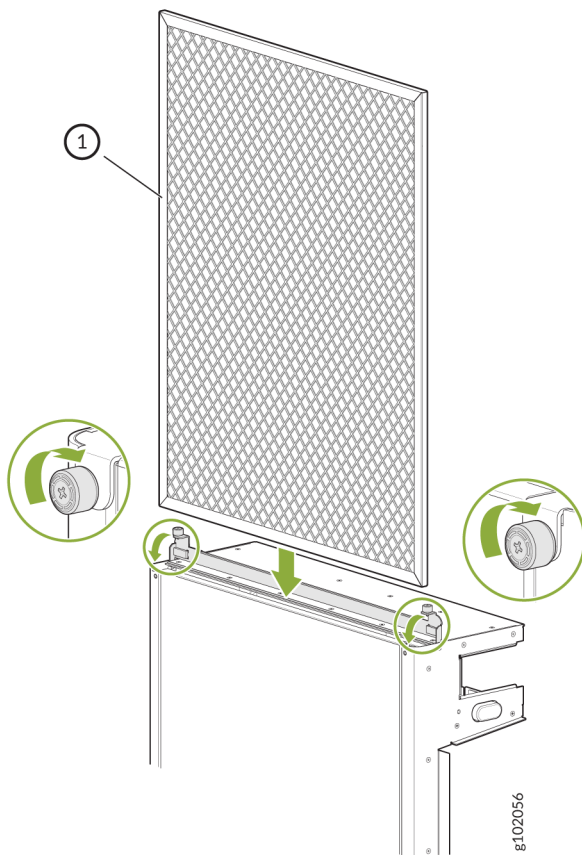
1– Air filter frame



CAUTION: We recommend that you install the air filter to prevent harmful debris from entering the chassis.

3. Hold the air filter with both hands and insert it into the front door until it stops. See [Figure 112 on page 314](#).

Figure 112: Insert the Air Filter into the JNP10008-FRPNL1 Front Door



1– Air filter

4. Move the air filter frame over the front door and turn the knob on the air filter frame clockwise back in place.

Remove the Air Filter from the JNP10008-FRPNL1 Front Door

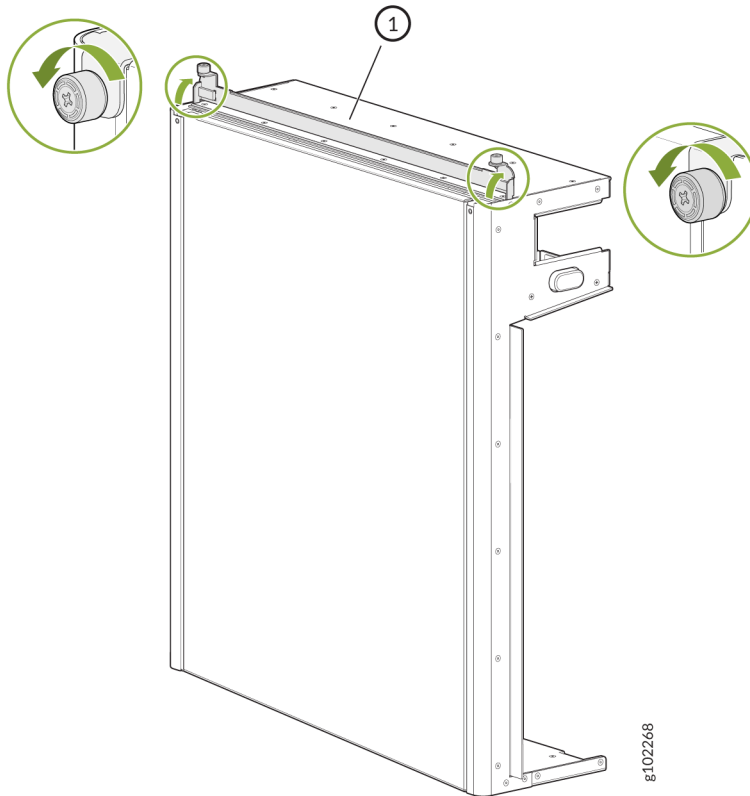
Before you remove the air filter from the front door:

- Ensure that you have followed all safety warnings and cautions.
- Ensure you understand how to prevent ESD damage. See "[Prevention of Electrostatic Discharge Damage](#)" on page 509.
- Ensure that you have the following parts and tools available:
 - An ESD grounding strap
 - Phillips (+) screwdriver, number 2

To remove the air filter:

1. Wrap and fasten one end of the ESD grounding strap around your bare wrist and connect the other end of the strap to the ESD point on the front of the chassis. See [Figure 103 on page 306](#).
2. Turn the thumbscrew on the air filter frame anti-clockwise and flip the frame open to expose the air filter (see [Figure 111 on page 313](#)).

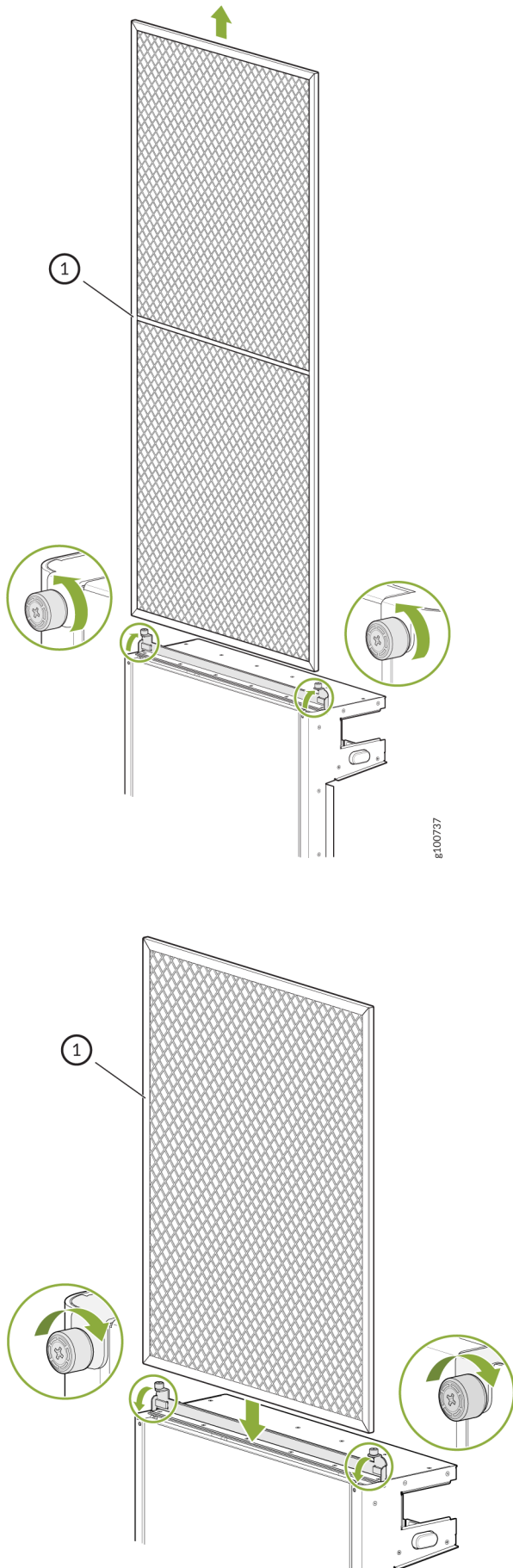
Figure 113: Expose the Air Filter in the JNP10008-FRPNL1 Front Door



1- Air filter frame

3. Grasp the air filter with both hands and lift it straight up and out of the front door (see [Figure 114 on page 317](#)).

Figure 114: Remove the Air Filter from the JNP10008-FRPNL1 Front Door



1– Air filter

4. Move the air filter frame over the front door and turn the thumbscrew on the air filter frame clockwise back in place.

Remove the Side EMI Deflectors from the Front Door

Before you remove the side EMI deflectors on the front door:

- Ensure that you have followed all safety warnings and cautions.
- Ensure you understand how to prevent ESD damage. See ["Prevention of Electrostatic Discharge Damage" on page 509](#).
- Ensure that you have the following parts and tools available:
 - An ESD grounding strap (provided in the accessory kit)
 - Phillips (+) screwdriver, number 2
 - An antistatic mat or an antistatic bag

To remove a side EMI deflector from the front door:

1. Loosen the captive screws on the side EMI deflector by using the screwdriver.
2. Gently pull the side EMI deflector away from the door and place it on an antistatic mat or in an antistatic bag.

Remove the Front Door from the PTX10008 Router

Before you remove the front door, ensure that you have the following tools and parts:

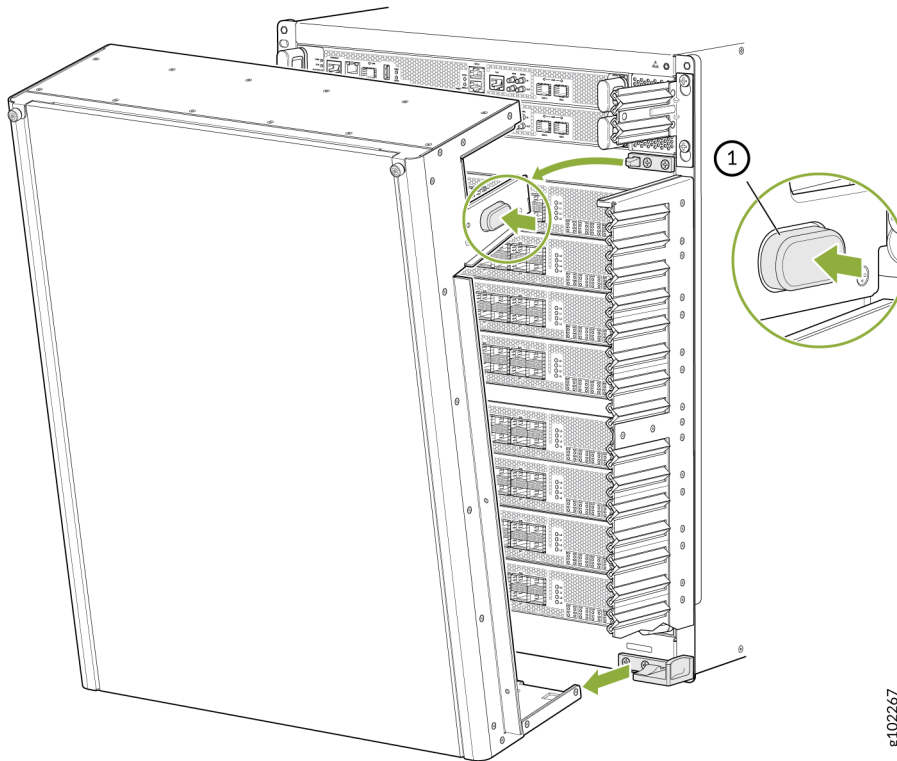
- An Electrostatic discharge (ESD) grounding strap
- An antistatic mat or an antistatic bag to keep the door

To remove the front door:

1. Wrap and fasten one end of the ESD grounding strap around your bare wrist and connect the other end of the strap to the ESD point on the front of the chassis. See [Figure 103 on page 306](#).
2. Turn the knobs of the side EMI deflector on either side of the door anti-clockwise to detach the side EMI deflector from the front door.

3. Gently pull the side EMI deflector away from the door and place it on an antistatic mat or in an antistatic bag.
4. Repeat the instructions in Step 2 and Step 3 to remove the other side EMI deflector.
5. Press the latch button to disengage the door (see [Figure 115 on page 319](#)) and gently pull the top of the door away from the chassis. The illustration shows the door with the part number JNP10008-FRNT-PNL. The procedure is the same for the door with the part number JNP10008-FRPNL1.

Figure 115: Remove the Front Door from the PTX10008 Chassis



8102267

1– Latch button

6. Gently lift the front door from the two base brackets by using your hands and move the door away from the chassis.
7. Place the door on the antistatic mat or in the antistatic bag.

Connect the PTX10008 to Power

IN THIS SECTION

- [Connect the PTX10008 Router to Earth Ground | 320](#)
- [Connect AC Power to a PTX10008 | 322](#)
- [Connect DC Power to a PTX10008 | 323](#)

PTX10008 routers support both AC, DC, high-voltage alternating current (HVAC) and high-voltage direct current (HVDC) power supplies. To connect power to a PTX10008 router, read the following procedures.

NOTE: Do not mix power supply models in the same chassis in a running environment. DC and HVDC can coexist in the same chassis during the hot swap of DC for HVDC.

Connect the PTX10008 Router to Earth Ground

To meet safety and electromagnetic interference (EMI) requirements and to ensure proper operation, you must connect the chassis to earth ground before you connect it to power.

You must install the PTX10008 in a restricted-access location and ensure that the chassis is always properly grounded. The PTX10008 has a two-hole protective grounding terminal provided on the chassis. See [Figure 117 on page 322](#). Under all circumstances, use this grounding connection to ground the chassis. For AC-powered systems, you must also use the grounding wire in the AC power cord along with the two-hole grounding lug connection. This tested system meets or exceeds all applicable EMC regulatory requirements with the two-hole protective grounding terminal.

If an external ground connection is required, ensure that a licensed electrician has attached an appropriate grounding lug to the grounding cable you supply. Using a grounding cable with an incorrectly attached lug can damage the switch.

NOTE: Mount your router in the rack before attaching the grounding lug to the router; see [Install the PTX10008 into a Rack](#).

Ensure that you have the following parts and tools available:

- An electrostatic discharge (ESD) grounding strap (provided).
- Protective earthing terminal lug for your grounding cable (provided)—This bracket attaches to the lower left corner of the router chassis next to the bottom power supply, providing a protective earthing terminal for the router. The grounding lug required is a Panduit LCD4-14A-L or equivalent.
- Grounding cable for your PTX10008 (not provided)—The grounding cable must be the same size or heavier than the input wire of each power supply.
- A Phillips screwdriver (not provided) to tighten the two screws that are mounted on the chassis.

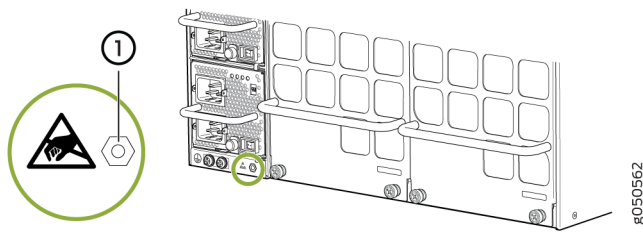
The terminal lugs provided for the JNP10K-PWR-DC2 are Panduit LCD4-14A-L, or equivalent, and sized for 4 AWG (21.1 mm²) power source cables. The 4 AWG (21.1 mm²) stranded wire should be rated 90° C, or per local electrical code. When using all JNP10K-PWR-DC power supply modules in the chassis, the DC power source cables that you provide must be 6 AWG (13.3 mm²) stranded wire. We recommend that you install heat-shrink tubing insulation around the crimped section of the power cables and lugs.

An AC-powered PTX10008 gains additional grounding when you plug the power supply in the router into a grounded AC power outlet by using an AC power cord appropriate for your geographical location. See ["PTX10008 Power Cables Specifications" on page 222](#).

To connect earth ground to a PTX10008:

1. Verify that a licensed electrician has attached the protective earthing terminal lug (provided in the accessory kit) to the grounding cable.
2. Connect the other end of the grounding cable to a proper earth ground, such as the rack in which the router is mounted.
3. Wrap and fasten one end of the ESD grounding strap around your bare wrist and connect the other end of the strap to one of the ESD points on the chassis (see [Figure 116 on page 322](#)).

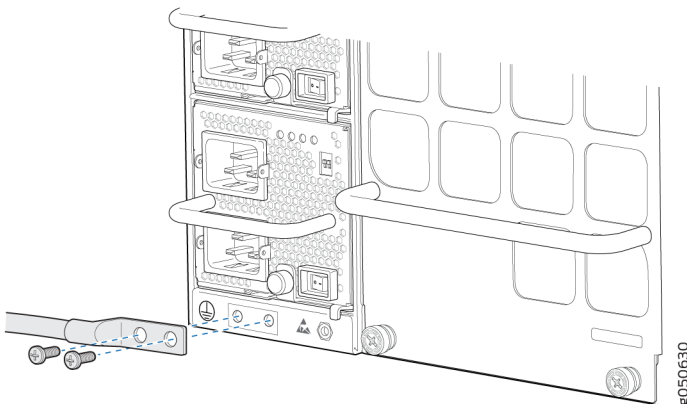
Figure 116: ESD Point for the PTX10008



1– ESD point

4. Remove the two screws on grounding terminal adjacent to the ESD point on the chassis using a Phillips screwdriver. Save the screws.
5. Place the chassis grounding lug and cable over the screw holes, with the cable connection pointing to the left. See [Figure 117 on page 322](#).

Figure 117: Connect a Grounding Cable to the PTX10008



6. Place the two screws over the grounding lug and grounding cable.
7. Tighten the two screws using a Phillips screwdriver.
8. Dress the grounding cable and ensure that it does not touch or block access to other device components and that it does not drape where people can trip over it.

Connect AC Power to a PTX10008

Before you begin to connect power to the router, be sure you understand how to prevent ESD damage. See *Prevention of Electrostatic Discharge Damage*.

After you ground the chassis, add power supplies, and supply power to the chassis, the system initiates the power-on sequence. This sequence can start incrementally with a single power supply, but we do not recommend that you bring up a PTX10008 system with less than three power supplies.

To connect AC power to a PTX10008 chassis:

1. Connect the chassis to earth ground (see ["Connect the PTX10008 Router to Earth Ground" on page 320](#)).



CAUTION: To meet safety and electromagnetic interference (EMI) requirements and to ensure proper operation, a PTX10008 must be adequately grounded before it is connected to power.

For installations that require a separate grounding conductor to the chassis, use the protective earthing terminal on the rear panel of the PTX10008 to connect to the earth ground.

A PTX10008 router gets additional grounding when you plug the power supply in the router into a grounded AC power outlet by using the AC power cord appropriate for your geographical location. See ["PTX10008 Power Cables Specifications" on page 222](#).

2. Install power supplies in the router and apply power. See ["Install a JNP10K-PWR-AC Power Supply" on page 362](#), ["Install a JNP10K-PWR-AC2 Power Supply" on page 372](#), and ["Install a JNP10K-PWR-AC3 Power Supply" on page 380](#).

SEE ALSO

[JNP10K-PWR-AC Power Supply | 76](#)

[Install a JNP10K-PWR-AC Power Supply | 362](#)

Connect DC Power to a PTX10008

Before you begin to connect power to the router, be sure you understand how to prevent electrostatic discharge (ESD) damage. See *Prevention of Electrostatic Discharge Damage*.

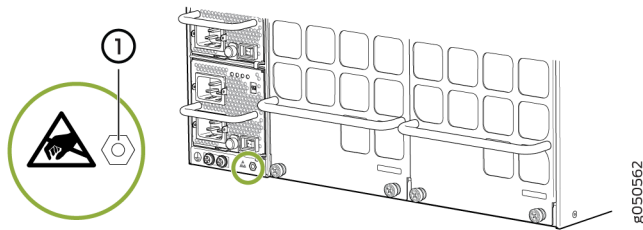
The overall process of bringing up a DC-powered chassis involves the proper cabling of the individual power supplies, adding the power supplies to the chassis, and supplying power. The power-on sequence can start incrementally with a single power supply, but it is not recommended that you bring up a PTX10008 system with less than three power supplies.

Each power supply input feed must be connected to a dedicated DC power source outlet.

To connect DC power to a PTX10008 chassis:

1. Connect the chassis to earth ground (see [Figure 118 on page 324](#)).

Figure 118: ESD Point for the PTX10008



1– ESD point



CAUTION: To meet safety and electromagnetic interference (EMI) requirements and to ensure proper operation, a PTX10008 router must be adequately grounded before it is connected to power.

For installations that require a separate grounding conductor to the chassis, use the protective earthing terminal on the rear panel of the PTX10008 to connect to the earth ground.

2. Connect DC power to the JNP10K-PWR-DC or JNP10K-PWR-DC2 power supplies and install in the chassis.

To connect DC power to a JNP10K-PWR-DC power supply, see "[Install a JNP10K-PWR-DC Power Supply](#)" on page 391. To connect DC power to a JNP10K-PWR-DC2 power supply, see "[Install a JNP10K-PWR-DC2 Power Supply](#)" on page 405.

SEE ALSO

[JNP10K-PWR-DC Power Supply](#) | 86

[Install a JNP10K-PWR-DC Power Supply](#) | 391

[JNP10K-PWR-DC2 Power Supply](#) | 88

[Install a JNP10K-PWR-DC2 Power Supply](#) | 405

RELATED DOCUMENTATION

General Safety Guidelines and Warnings

Grounded Equipment Warning

Connect the PTX10008 to External Devices

IN THIS SECTION

- [Connect a PTX10008 Router to a Network for Out-of-Band Management | 325](#)
- [Connect a PTX10008 Router to a Management Console | 326](#)
- [Connect the Router to External Clocking and Timing Devices | 328](#)

You can manage the PTX10008 router by using the two management ports on the Routing and Control Board (RCB) for out-of-band management or through the console port on the RCB. To connect a PTX10008 router to external management devices, read the following sections.

Connect a PTX10008 Router to a Network for Out-of-Band Management

Ensure that you have an appropriate cable available. See "[Management Port Connector Pinouts for the PTX10008 Router](#)" on page 278 and "[Connect a PTX10008 Router to a Management Console](#)" on page 326.

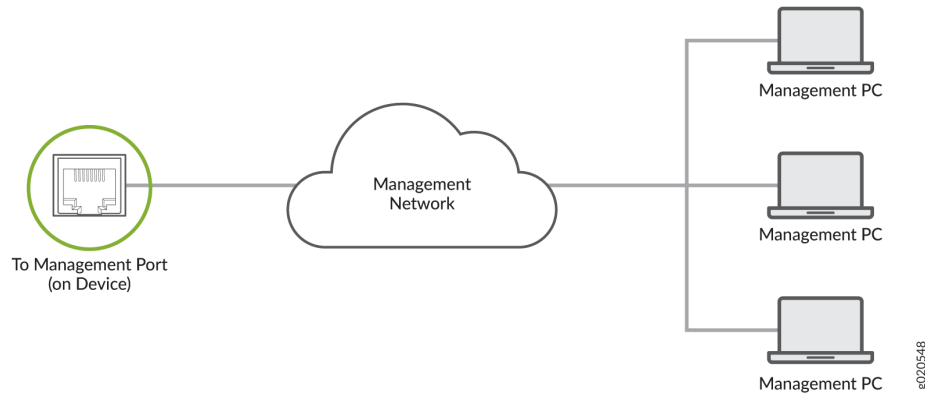
You can monitor and manage a PTX10008 router using a dedicated management channel. Each PTX10008 Routing and Control Board (RCB) has two management ports: a 10/100/1000BASE-T RJ-45 port for copper connections and a 1-Gigabit SFP port for fiber connections. Use the management ports to connect the RCB to a network for out-of-band management.

NOTE: You cannot use the management ports to perform the initial configuration of the PTX10008. You must configure the management ports before you can successfully connect to the PTX10008 using these ports. See "[Perform the Initial Configuration for the PTX10008 Router](#)" on page 332.

To connect a PTX10008 to a network for out-of-band management (see [Figure 119 on page 326](#)):

1. Connect one end of the cable to one of the two management ports (labeled **MGMT**) on one of the RCBs.
2. Connect the other end of the cable to the management router.

Figure 119: Connect a PTX10008 to a Network for Out-of-Band Management



Connect a PTX10008 Router to a Management Console

Ensure that you have an RJ-45 to DB-9 rollover cable available.

NOTE: If your laptop or PC does not have a DB-9 plug connector pin and you want to connect your laptop or PC directly to the PTX10008 router, use a combination of an RJ-45 to DB-9 cable and a USB to DB-9 plug adapter. You must provide the USB to DB-9 plug adapter.

NOTE: We no longer include the RJ-45 console cable with the DB-9 adapter as part of the device package. If the console cable and adapter are not included in your device package, or if you need a different type of adapter, you can order the following separately:

- RJ-45 to DB-9 adapter (JNP-CBL-RJ45-DB9)
- RJ-45 to USB-A adapter (JNP-CBL-RJ45-USBA)

- RJ-45 to USB-C adapter (JNP-CBL-RJ45-USBC)

If you want to use RJ-45 to USB-A or RJ-45 to USB-C adapter you must have X64 (64-Bit) Virtual COM port (VCP) driver installed on your PC. See, <https://ftdichip.com/drivers/vcp-drivers/> to download the driver.

The PTX10008 router has a console port with an RJ-45 connector. Use the console port to connect the device to a management console or to a console server.

To connect the PTX10008 router to a management console (see [Figure 120 on page 327](#) and [Figure 121 on page 327](#)):

1. Connect one end of the Ethernet cable to the console port (labeled **CON**).
2. Connect the other end of the Ethernet cable into the console server (see [Figure 120 on page 327](#)) or management console (see [Figure 121 on page 327](#)).

Figure 120: Connect the PTX10008 Router to a Management Console Through a Console Server

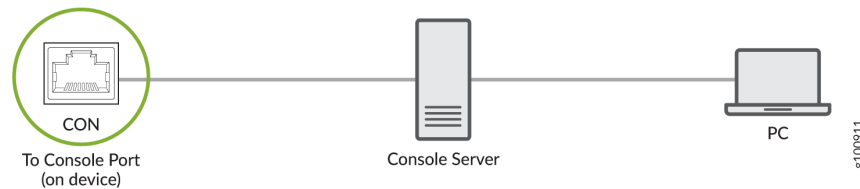
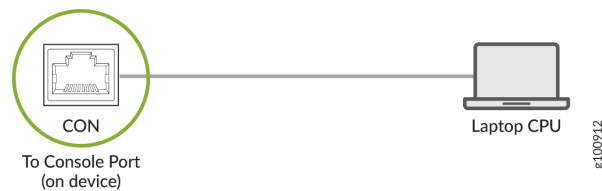


Figure 121: Connect the PTX10008 Router Directly to a Management Console



Connect the Router to External Clocking and Timing Devices

IN THIS SECTION

- [Connect the Router to a 1PPS and 10MHz Timing Device | 328](#)
- [Connect the Router to a Time-of-Day Device | 329](#)
- [Connect the Router to a BITS External Clocking Device | 331](#)

The router supports external clock synchronization for Synchronous Ethernet and external inputs.

Connect the Router to a 1PPS and 10MHz Timing Device

The routing and control boards installed in the router has GPS clock ports that you can use to connect the router to a 1PPS and 10MHz timing device. [Table 115 on page 328](#) describes the GPS clock ports on the router.

Table 115: GPS Clock Ports on the Router

Label	Description
1PPS – IN	1 PPS input port
10MHz – IN	10 MHz input port
1PPS – OUT	1 PPS output port
10MHz – OUT	10 MHz output port

You can configure the router as a timing primary device or a client device. If you configure the router as a timing primary device, the router receives inputs from the timing device through the input ports and sends outputs to a client device through the output ports. If you configure the router as a timing client device, the router receives inputs from the timing device through the input ports.

Before you connect the router to a 1PPS and 10MHz timing device, ensure that you have two cables that meet the specifications in [Table 116 on page 329](#).

Table 116: GPS Port Cable Specifications

Specifications	Value
Cable type	Coaxial
Connectors at the router end	2x1 DIN 1.0/2.3 latching male connectors
Connectors at the timing device end	Compatible with the ports on the timing device
Maximum length	9.84 feet (3 m)
Impedance	50 ohms

To connect the router to a 1PPS and 10MHz timing device:

1. Connect one end of the cables to the input ports on the router.

If the router is a timing primary device, connect the router to a client device by using the output ports.

NOTE: Ensure that the timing device supports an input or output impedance of 50 ohms, and supports input and output voltage levels that comply with ITU G.703. The timing device inputs must be 5V tolerant.

2. Connect the other end of the cables to the 1PPS and 10MHz connectors on the timing device.

Connect the Router to a Time-of-Day Device

The JNP10K-RE1, JNP10K-RE1-E, JNP10K-RE1-LT, and JNP10K-RE1-ELT routing and control boards installed in the router have a time-of-day (ToD) port labeled **ToD**. You can use that port to connect the router to a ToD timing device.

Before you connect the router to a ToD timing device, ensure that you have an ESD grounding strap and a cable that meets the specifications in [Table 117 on page 330](#).

Table 117: ToD Port Cable Specifications

Specifications	Value
Cable type	RS-232 (EIA-232) serial cable
Connector at the router end	RJ-45
Connector at the timing device end	RJ-45
Maximum length	19.69 feet (6 m)

[Table 118 on page 330](#) provides the pinout information for the RS-232 connector for the ToD port.

Table 118: ToD Port Connector Pinouts

Pin	Description	Direction
1	Reserved	-
2	Reserved	-
3	Transmit Data	Output
4	Signal Ground	-
5	Signal Ground	-
6	Receive Data	Input
7	Reserved	-
8	Reserved	-

To connect the router to a ToD timing device:

1. Wrap and fasten one end of the ESD grounding strap around your bare wrist and connect the other end of the strap to one of the ESD points on the chassis.
2. Plug one end of the RJ-45 cable into the **ToD** port.
3. Plug the other end of the RJ-45 cable into the ToD timing device.
4. Configure the port.

Connect the Router to a BITS External Clocking Device

The JNP10K-RE1, JNP10K-RE1-E, JNP10K-RE1-LT, and JNP10K-RE1-ELT routing and control boards installed in the router have two building-integrated timing supply (BITS) ports labeled **BITS-0** and **BITS-1**. You can use them to connect the router to a BITS timing device.

Before you connect the router to a BITS timing device, ensure that you have an ESD grounding strap and a cable that meets the specifications in [Table 119 on page 331](#).

Table 119: BITS Port Cable Specifications

Specifications	Value
Cable type	RJ-48 shielded cable
Connector at the router end	Autosensing RJ-48 connector

[Table 120 on page 331](#) provides the pinout information for the RJ-48 connector for the BITS ports.

Table 120: BITS Ports Pinouts

Pin Number	Description	Direction
1	EXT_CLKA_RRING_LINE	Input
2	EXT_CLKA_RTIP_LINE	Input
3	Reserved	–
4	EXT_CLKA_TRING_LINE	Output
5	EXT_CLKA_TTIP_LINE	Output

Table 120: BITS Ports Pinouts (*Continued*)

Pin Number	Description	Direction
6	Reserved	-
7	Reserved	-
8	Reserved	-

To connect the router to a BITS timing device:

1. Wrap and fasten one end of the ESD grounding strap around your bare wrist and connect the other end of the strap to one of the ESD points on the chassis.
2. Plug one end of the RJ-45 cable into a BITS port.
3. Plug the other end of the RJ-45 cable into the BITS external clocking device.
4. Verify that the LED for the **BITS** port is lit steadily green.
5. Configure the port.

RELATED DOCUMENTATION

[PTX10008 Routing and Control Board Components and Descriptions | 105](#)

[Management Port Connector Pinouts for the PTX10008 Router | 278](#)

[Console Port Connector Pinouts for a PTX10008 | 275](#)

Perform the Initial Configuration for the PTX10008 Router

IN THIS SECTION

- [Before You Start | 333](#)
- [Enter Configuration Mode | 334](#)

- [Establish a Root Password and Optional Host Name | 335](#)
- [Configure the Default Gateway and Ethernet Interface | 335](#)
- [Configure Optional Routes, Services, and Commit the Configuration | 336](#)

You must perform the initial configuration of the PTX10008 through the console port using the CLI or through Zero Touch Provisioning (ZTP). In order to use ZTP to provision the device, you must have access to a Dynamic Host Control Protocol (DHCP) server, and a File Transfer Protocol (anonymous FTP), Hypertext Transfer Protocol (HTTP), or Trivial File Transfer Protocol (TFTP) server on which the software image and configuration files are stored. For more information about using ZTP for provisioning the device, see [Understanding Zero Touch Provisioning](#) in the *Software Installation and Upgrade Guide*.

These procedures step you through the configuration of the PTX10008 using the console **CON|CONSOLE** port on the Routing and Control Board (RCB). For directions on connecting into a console server or a management server, see "[Connect a PTX10008 Router to a Management Console](#)" on page [326](#).

Before You Start

1. Set the following values on the console server or PC:
 - Baud Rate—9600
 - Flow Control—None
 - Data—8
 - Parity—None
 - Stop Bits—1
 - DCD State—Disregard
2. Gather the information you will need for configuring the PTX10008:
 - The password you'll set for the root user
 - The name on the system that the PTX10008 will be known as (host name)
 - The IP address and prefix of the default gateway router
 - The IP address and prefix length information for the Ethernet interface

- The IP address and prefix length of remote prefixes

Enter Configuration Mode

1. Check that the PTX10008 has power.
2. Connect the console port to a laptop or PC using an RJ-45 cable and RJ-45 to DB-9 adapter. The console (**CON**) port is located on the port panel of the router.

NOTE: We no longer include the RJ-45 console cable with the DB-9 adapter as part of the device package. If the console cable and adapter are not included in your device package, or if you need a different type of adapter, you can order the following separately:

- RJ-45 to DB-9 adapter (JNP-CBL-RJ45-DB9)
- RJ-45 to USB-A adapter (JNP-CBL-RJ45-USBA)
- RJ-45 to USB-C adapter (JNP-CBL-RJ45-USBC)

If you want to use RJ-45 to USB-A or RJ-45 to USB-C adapter you must have X64 (64-Bit) Virtual COM port (VCP) driver installed on your PC. See, <https://ftdichip.com/drivers/vcp-drivers/> to download the driver.

3. Log in as **root**. There is no password. If the software booted before you connected to the console port, you might need to press the Enter key for the prompt to appear.

```
Amnesiac <ttyd0>  
login: root
```

4. Start the CLI.

```
root% cli
```

5. Enter configuration mode.

```
root> configure
```

Establish a Root Password and Optional Host Name

1. Add a password to the root administration user account.

```
[edit]
root@# set system root-authentication plain-text-password
New password: password
Retype new password: password
```

2. (Optional) Configure the name of the router. If the name includes spaces, enclose the name in quotation marks (" ").

```
[edit]
root@# set system host-name host-name
```

Configure the Default Gateway and Ethernet Interface

1. Configure the default gateway.

- For Junos OS system:

```
[edit]
root@# set routing-options static route default next-hop address
```

- For Junos OS Evolved system:

```
[edit]
root@# set system management-instance
root@# set routing-instances mgmt_junos routing-optins static route prefix/prefix-length next-hop
default-gateway-ip-address
```

2. Configure the IP address and prefix length for the router management interface.

- For Junos OS system:

```
[edit]
root@# set interfaces em0 unit 0 family inet address ip-address/prefix-length
```

- For Junos OS Evolved system:

```
[edit]
root@# set interfaces re0:mgmt-0 unit 0 family inet address ip-address/prefix-length
```



CAUTION: Though the CLI permits you to configure two management Ethernet interfaces within the same subnet, only one interface is usable and supported.

NOTE: The management ports, `em0` or `re0:mgmt-0` for RJ-45 connections (labeled **MGMT**) and `em1` for fiber connections (also labeled **MGMT**), are found on the front of the RCBs.

Configure Optional Routes, Services, and Commit the Configuration

1. (Optional) Configure the static routes to remote prefixes with access to the management port.

```
[edit]
root@# set routing-options static route remote-prefix next-hop destination-ip retain no-readvertise
```

2. Enable services such as SSH and Telnet.

NOTE: You will not be able to log in to the router as the `root` user through Telnet. Root login is allowed only through SSH.

```
[edit]
root@# set system services telnet
```

3. Commit the configuration to activate it on the router.

```
[edit]
root@# commit
```

RELATED DOCUMENTATION

[PTX10008 Hardware Overview | 15](#)

[PTX10008 Installation Overview | 280](#)

5

CHAPTER

Hardware Upgrades

PTX10008 Hardware Upgrade Procedures | 339

PTX10008 Hardware Upgrade Procedures

IN THIS SECTION

- [Before You Begin | 339](#)
- [Remove PTX10008 Components for Upgrade | 340](#)
- [Install the PTX10008 Upgrade Components | 340](#)

QFX10008, MX10008, and older versions of the PTX10008 can future-proof their chassis investment by upgrading their systems to the latest PTX10008 running Juniper Junos OS Evolved system. The following sections guide you through the planning and installation process of upgrading your system to a PTX10008 router that can support the latest switch fabric and 14.4 Tbps line cards.

Before You Begin

Before you begin the chassis upgrade, it is a good idea to back up your existing configuration to a storage location for reference. QFX Series and MX Series systems becoming PTX Series systems need some configuration to operate in the new environment.

Schedule the upgrade in a maintenance window with sufficient time to remove all the components, install new components, and configure the new PTX10008 router.

Use the appropriate hardware guide for your current system to order the correct upgrade kit, power off the system, and to remove components. See:

- [MX10008 Universal Routing Platform Hardware Guide](#)
- [QFX10008 Switch Hardware Guide](#)
- The following sections for PTX10008:
 - For ordering upgrade kits (see "[PTX10008 Configurations and Upgrade Options](#)" on page 31).
 - For powering off the system and removing power cables (see "[Power Off a PTX10008](#)" on page 449).
 - For removing existing components (see "[Remove PTX10008 Components for Upgrade](#)" on page 340).

Remove PTX10008 Components for Upgrade

Ensure you are familiar with how to safely store and handle PTX10008 components before starting your upgrade. See:

- ["How to Handle and Store PTX10008 Line Cards, RCBs, and SIBs" on page 420](#)
- ["How to Handle and Store PTX10008 Line Cards, RCBs, and SIBs" on page 420](#)
- ["How to Handle and Store PTX10008 Line Cards, RCBs, and SIBs" on page 420](#)

Remove and safely store the following components in this order:

1. Optical cables and connections to external devices (see ["Remove a Transceiver From a PTX0008" on page 444](#))
2. Power supplies and power cables (see ["Install and Remove PTX10008 Power System Components" on page 361](#))
3. Line cards (see ["Remove a PTX10008 Line Card" on page 437](#))
4. Routing and Control Boards (RCBs) (see ["Remove a PTX10008 Routing and Control Board" on page 345](#))
5. Fan trays (see ["Remove a PTX10008 Fan Tray" on page 351](#))
6. Switch Interface Boards (SIBs) (see ["Remove a PTX10008 Switch Interface Board" on page 429](#))
7. JNP10008-FAN-CTRL fan controllers (see ["Remove a PTX10008 Fan Tray Controller" on page 358](#))
If you have JNP10008-FTC2 installed, you may skip this step.

Install the PTX10008 Upgrade Components

After the upgrade kits are on the premises:

1. Unpack the upgrade kit (see ["Unpack Line Cards, Routing Control Boards, and Switch Interface Boards for the PTX10008" on page 283](#)).
2. Compare the contents of the kit to the order, see (["Compare the PTX10008 Order to the Packing List" on page 285](#)).
3. Install the components in the following order:



CAUTION: The installation order of components is important. To avoid cooling problems, do not apply power until all components are installed.

- a. Fan tray controllers JNP10008-FTC2 (see ["Install a PTX10008 Fan Tray Controller" on page 355](#))

- b. SIBs JNP10008-SF3 (see ["Install a PTX10008 Switch Interface Board" on page 424](#))
 - c. Fan trays JNP10K-FAN2 (see ["Install a PTX10008 Fan Tray" on page 348](#))
 - d. RCBs JNP10K-RE1-E (see ["Install a PTX10008 Routing and Control Board" on page 343](#))
 - e. Line cards PTX10K-LC1201-36CD or PTX10K-LC1202-36MR (see ["Install a PTX10008 Line Card" on page 434](#))
 - f. Install power supplies JNP10K-PWR-AC2 or JNP10K-PWR-DC2 (see ["Install a JNP10K-PWR-AC2 Power Supply" on page 372](#) or ["Install a JNP10K-PWR-DC2 Power Supply" on page 405](#))
 - g. Install optics (see ["Install a PTX10008 Transceiver" on page 443](#))
4. Perform the first-time configuration (see ["Perform the Initial Configuration for the PTX10008 Router" on page 332](#)).
 5. Update your installation base with Juniper Networks (see ["Register Products—Mandatory to Validate SLAs" on page 291](#)).



CHAPTER

Maintain Components

[Install and Remove PTX10008 Routing and Control Boards | 343](#)

[Install and Remove PTX10008 Cooling System Components | 347](#)

[Install and Remove PTX10008 Power System Components | 361](#)

[Install and Remove PTX10008 Switch Fabric Components | 420](#)

[Install and Remove PTX10008 Line Card Components | 433](#)

[PTX10008 Transceiver and Fiber Optic Cable Installation and Removal | 442](#)

[Remove the PTX10008 Router | 449](#)

Install and Remove PTX10008 Routing and Control Boards

IN THIS SECTION

- [Install a PTX10008 Routing and Control Board | 343](#)
- [Remove a PTX10008 Routing and Control Board | 345](#)

We ship PTX10008 routers with one or two Routing and Control Boards (RCBs) preinstalled in the chassis, depending on the configuration. You can install RCBs in the two top slots on the front of the chassis.

When you power on a router with a single RCB preinstalled in it, the RCB comes online as the primary and powers on the line cards and the switch fabric. If you install the second RCB, it powers up and the Routing Engine comes online in the backup mode; you must bring the control board of that RCB online by using the [request chassis cb online](#) command.

When you power on a router with two RCBs installed in it for the first time, the RCB installed in slot **CB 0** comes online as the primary (RE0 in the CLI) and powers on the line cards and the switch fabric, and the RCB installed in slot **CB 1** comes online as the backup (RE1 in the CLI) by default. You can change this configuration by using the CLI. If you replace an RCB, it powers up and the Routing Engine comes online in the backup mode; you must bring the control board of that RCB online by using the [request chassis cb online](#) command.

To install or remove an RCB, read the following sections.

Install a PTX10008 Routing and Control Board

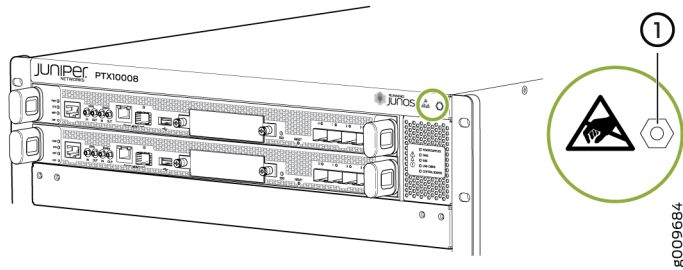
In redundant configurations, a PTX10008 RCB is a hot-removable and hot-insertable field-replaceable unit (FRU). In base configurations, you need to install a second RCB before removing a failing RCB in order to prevent the router from shutting down.

Before you install an RCB, ensure that you have an electrostatic discharge (ESD) grounding strap.

To install an RCB:

1. Wrap and fasten one end of the ESD grounding strap around your bare wrist and connect the other end of the strap to one of the ESD points on the chassis (see [Figure 122 on page 344](#)).

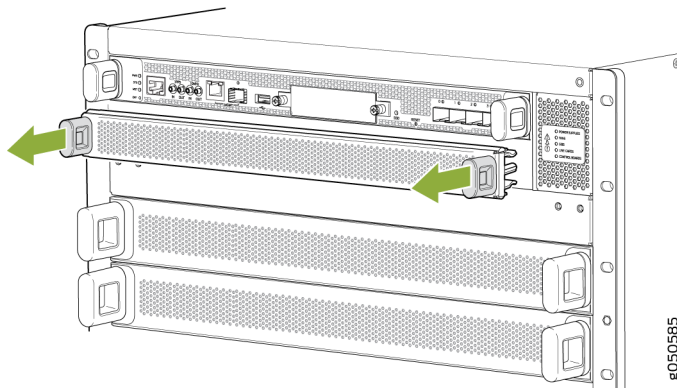
Figure 122: ESD Point on the Front of the PTX10008 Chassis



1– ESD point

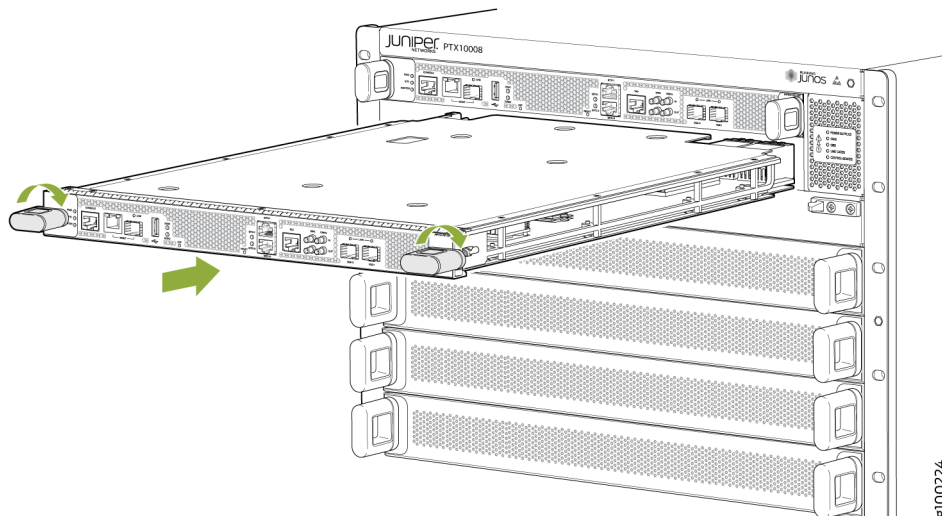
2. Either remove the cover from the available RCB slot (see [Figure 123 on page 344](#)) or remove the failing RCB (see ["Remove a PTX10008 Routing and Control Board" on page 345](#)).

Figure 123: Remove an RCB Cover



3. Remove the new RCB from the antistatic bag and inspect it for any damage before installing it into the chassis.
4. Lift the RCB by its sides, being careful not to bump the connectors.
5. Carefully align the sides of the RCB with the guides inside the chassis.
6. Slide the RCB into the chassis, carefully ensuring that it is correctly aligned.
7. Grasp both handles on the RCB and rotate them simultaneously clockwise until the RCB is fully seated and the handles are vertical (see [Figure 124 on page 345](#)).

Figure 124: Install an RCB



The RCB begins the power-on sequence when fully seated.

8. To verify that the RCB is functioning normally, check the **PWR** LED on its faceplate and the **CONTROL BOARDS** LED on the status panel. Both LEDs should light steadily shortly after the RCB is installed. If the **PWR** LED is blinking yellow, there might be insufficient power available. See ["PTX10008 Power Planning for JNP10008-SF Switch Fabric" on page 207](#) and ["PTX10008 Power Planning for JNP10008-SF3 Switch Fabric" on page 244](#) to ensure that you have adequate power for the additional unit.

Another method of verifying that the RCB is online is to use the following CLI command:

```
user@host> show chassis environment cb
```

SEE ALSO

[Power Requirements for PTX10008 Components in a JNP10008-SF Fabric | 208](#)

[PTX10008 Routing and Control Board LEDs | 109](#)

Remove a PTX10008 Routing and Control Board

In redundant configurations, a PTX10008 RCB is a hot-removable and hot-insertable field-replaceable unit (FRU). In base configurations, you need to install a second RCB before removing a failing RCB in order to prevent the router from shutting down. We recommend that you take base systems offline before replacing the RCB.

Before you remove a RCB, ensure that you have an electrostatic discharge (ESD) grounding strap.



CAUTION: In base configurations, removal of the RCB causes the system to shut down. In redundant configurations, removal of the RCB causes the system to reboot and start the election process for a new primary.

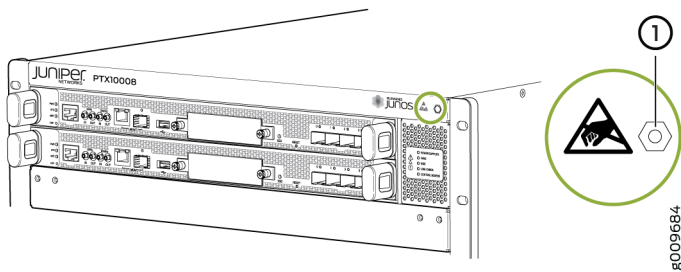
To remove a RCB:

1. Take the RCB offline.

Place an antistatic bag or antistatic mat on a flat, stable surface.

2. Wrap and fasten one end of the ESD grounding strap around your bare wrist and connect the other end of the strap to one of the ESD points on the chassis (see [Figure 125 on page 346](#)).

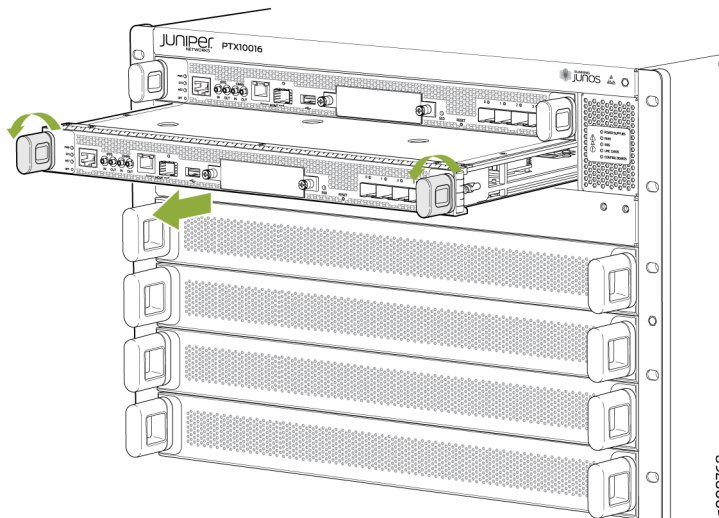
Figure 125: ESD Point on the Front of the PTX10008 Chassis



1- ESD point

3. Simultaneously rotate the RCB handles counterclockwise to unseat the RCB.
4. Grasp the handles and slide the RCB about halfway out of the chassis (see [Figure 126 on page 347](#)).

Figure 126: Remove an RCB



5. Grasp each side of the RCB and slide it completely out of the chassis.
6. Place the RCB on the antistatic mat.
7. If you are not replacing the RCB immediately, install a cover in the empty slot.

SEE ALSO

[How to Handle and Store PTX10008 Line Cards, RCBs, and SIBs](#) | 420

Install and Remove PTX10008 Cooling System Components

IN THIS SECTION

- [Install a PTX10008 Fan Tray](#) | 348
- [Remove a PTX10008 Fan Tray](#) | 351
- [Install a PTX10008 Fan Tray Controller](#) | 355
- [Remove a PTX10008 Fan Tray Controller](#) | 358

The PTX10008 router has two independent, field-replaceable fan trays. To install or remove the fan trays and fan tray controller, see the following sections.

Install a PTX10008 Fan Tray

Before you begin to install a fan tray:

- Ensure that you understand how to prevent ESD damage. See *Prevention of Electrostatic Discharge Damage*.
- Ensure that you have the following parts and tools available to install a fan tray in a PTX10008 router:
 - Electrostatic discharge (ESD) grounding strap
 - A Phillips (+) screwdriver, number 1 or 2 (optional), for the captive screws
 - A replacement fan tray

If you are upgrading a JNP10008-SF fabric system to use JNP10008-FAN2 and JNP10008-FTC2 cooling, also upgrade your power supplies to ensure the proper airflow. JNP10008-FAN2 and JNP10008-FTC2 cooling systems require either JNP10K-PWR-AC2 or JNP10K-PWR-DC2 power supplies.

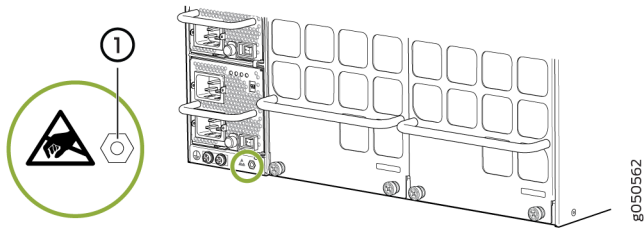
Each fan tray is a hot-removable and hot-insertable field-replaceable unit (FRU); you can remove and replace the fan tray while the router is running without turning off power to the router or disrupting routing functions. There are two models of the fan tray, JNP10008-FAN and JNP10008-FAN2.

Each fan tray is installed vertically on the rear, or FRU side, of the chassis.

To install any PTX10008 fan tray:

1. Wrap and fasten one end of the ESD grounding strap around your bare wrist and connect the other end of the strap to one of the ESD points on the chassis (see [Figure 127 on page 349](#)).

Figure 127: ESD Point on the Rear of the PTX10008 Chassis



1– ESD point

2. Grasp the top and bottom fan tray handles and align the bottom of the fan tray with the bottom of the fan tray slot.
3. Rest the bottom edge of the fan tray in the slot and slide the fan tray into place so it is fully seated.
4. Tighten the captive screws until the screws are finger tight. See [Figure 128 on page 350](#) and [Figure 129 on page 351](#).

Figure 128: Install the Fan Tray JNP10008-FAN in a PTX10008

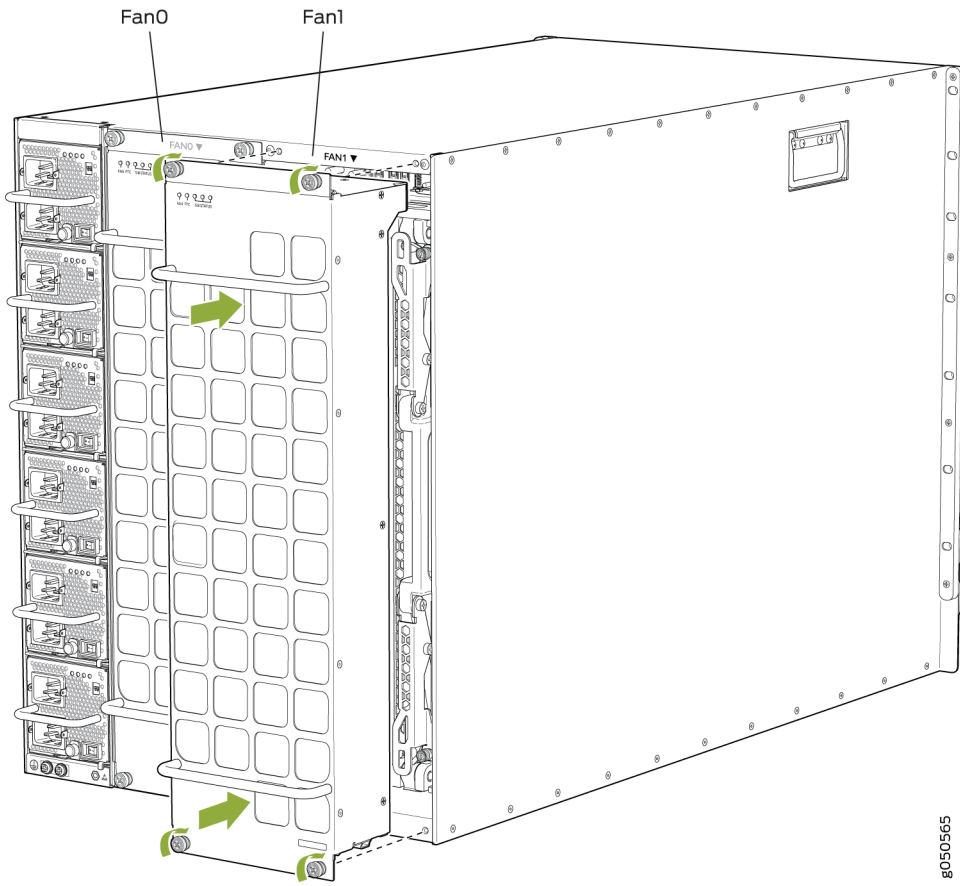
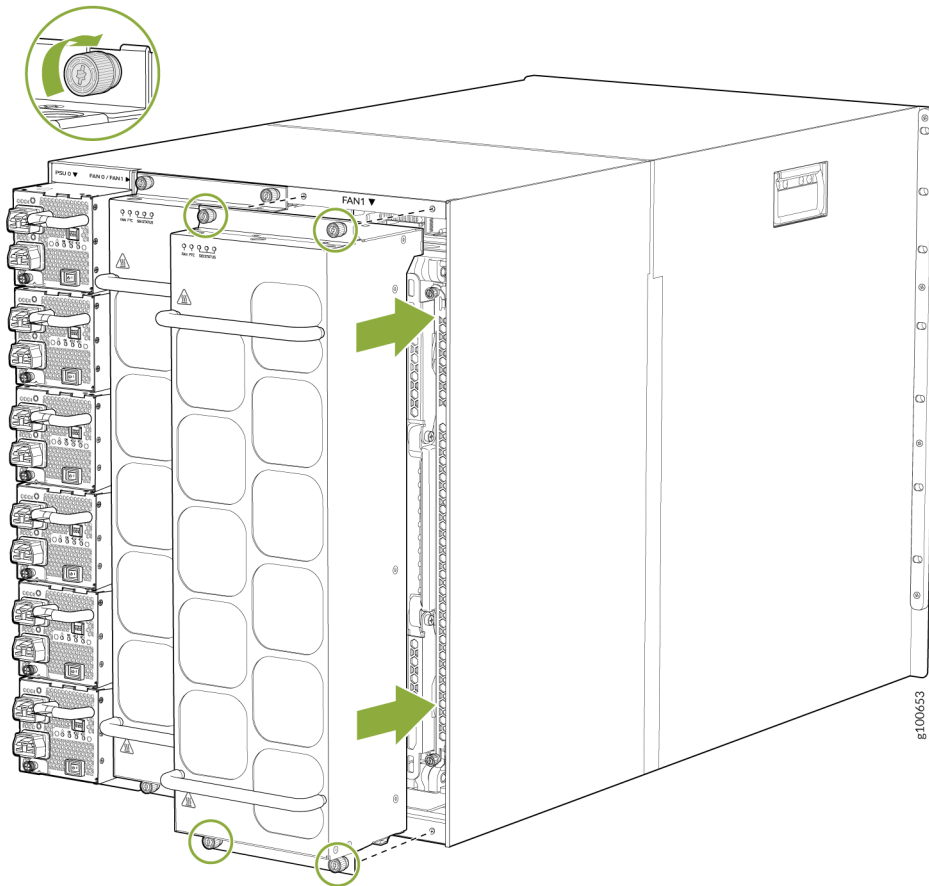


Figure 129: Install the Fan Tray JNP10008-FAN2 in a PTX10008



Remove a PTX10008 Fan Tray

The PTX10008 chassis has two independent, field-replaceable fan trays. Each fan tray is a hot-removable and hot-insertable field-replaceable unit (FRU); you can remove and replace the fan tray while the router is running without turning off power to the router or disrupting routing functions. There are two models of fan tray for the PTX10008 (JNP10008-FAN and JNP10008-FAN2).

Each fan tray is installed vertically on the rear, or FRU-side, of the chassis.

Before you remove a fan tray:

- Ensure that you understand how to prevent ESD damage. See *Prevention of Electrostatic Discharge Damage*.
- Ensure that you have the following parts and tools available:

- Electrostatic discharge (ESD) grounding strap
- A replacement fan tray
- A Phillips (+) screwdriver, number 1 or 2 (optional), for the captive screws

NOTE: If you are replacing the fans, run the fans at 100% speed for at least 10 minutes before you start the replacement procedure.

If Junos OS is installed in your router, use the `test chassis fan tray 0 speed full-speed` and `test chassis fan tray 1 speed full-speed` commands to configure the fans to operate at 100% speed.

If Junos OS Evolved is installed in your router, use the `request chassis fan tray 0 speed 100` and `request chassis fan tray 1 speed 100` commands to configure the fans to operate at 100% speed.

After you replace the fan tray, you must configure the fan trays to operate at the normal speed. If Junos OS is installed in your router, use the `test chassis fan tray 0 speed normal` and `test chassis fan tray 1 speed normal` commands to configure the fan trays to operate at the normal speed.

If Junos OS Evolved is installed in your router, use the `request chassis fan tray 0 speed normal` and `request chassis fan tray 1 speed normal` commands to configure the fan trays to operate at the normal speed.

You must replace only one fan tray at a time.

You must replace the fan tray within the time mentioned in [Table 121 on page 352](#) of removing the fan tray to prevent overheating of the chassis. If you are removing a JNP10008-FAN2 fan tray to access a JNP10008-SF3 Switch Interface Board (SIB), we recommend that you either perform the necessary work during a maintenance window or reinstall the fan tray within time mentioned in [Table 121 on page 352](#).

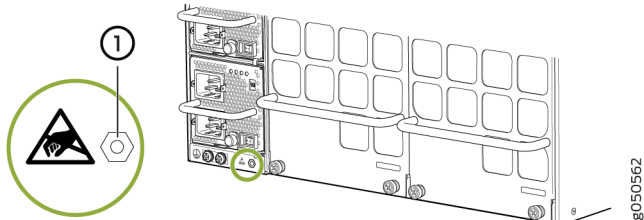
Table 121: Replacement Duration for the Fan Tray

Chassis Ambient Temperature	Duration
20° C	5 minutes
30° C	2.3 minutes
40° C	1.2 minutes

To remove a PTX10008 fan tray (JNP10008-FAN or JNP10008-FAN2):

1. Wrap and fasten one end of the ESD grounding strap around your bare wrist and connect the other end of the strap to one of the ESD points on the chassis (see [Figure 130 on page 353](#)).

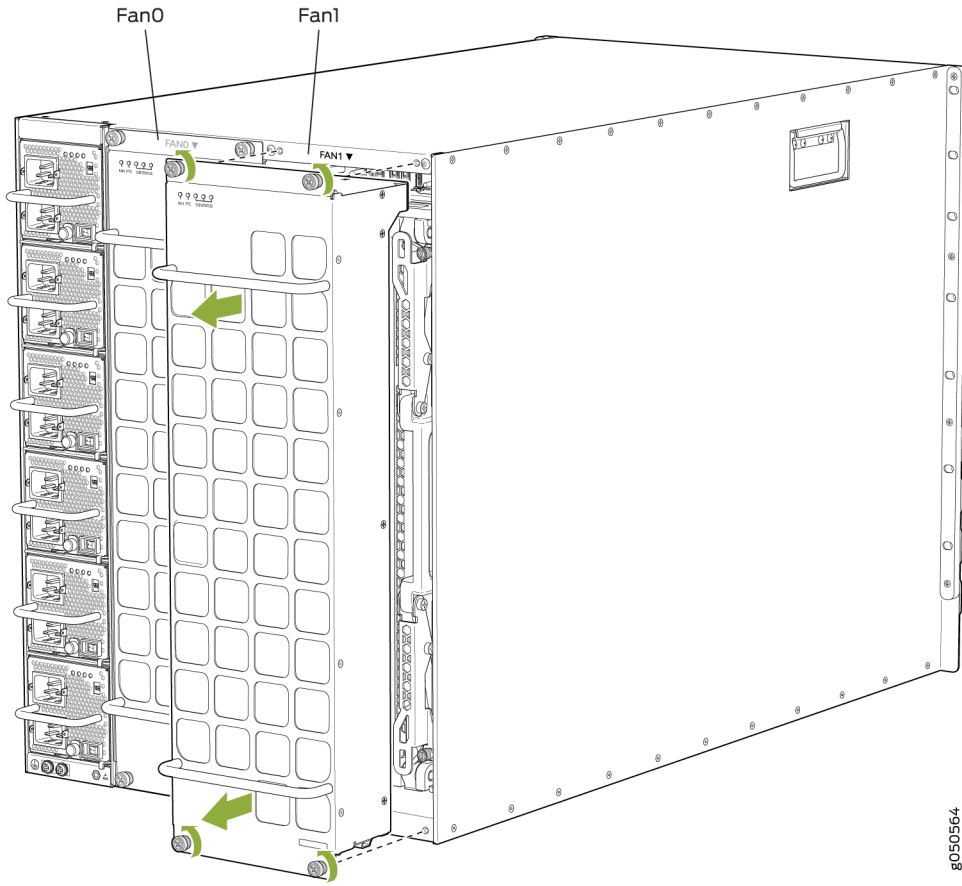
Figure 130: ESD Point on the Rear of the PTX10008



1- ESD point

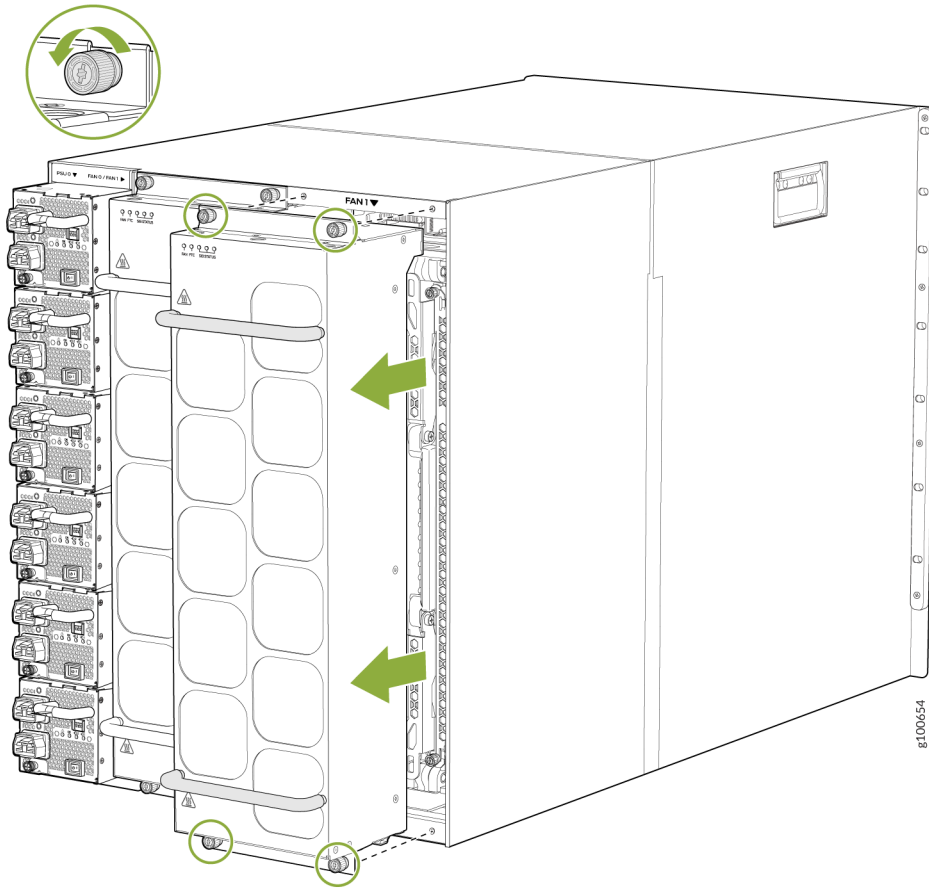
2. Loosen the four captive screws either by unscrewing with your thumb and forefinger or with a Phillips screwdriver.
3. Grasp the top and bottom handles and pull the fan tray out about 3 in. (7.6 cm). See [Figure 131 on page 354](#) and [Figure 132 on page 355](#).

Figure 131: Remove a JNP10008-FAN Fan Tray



8050564

Figure 132: Remove a JNP10008-FAN2 Fan Tray



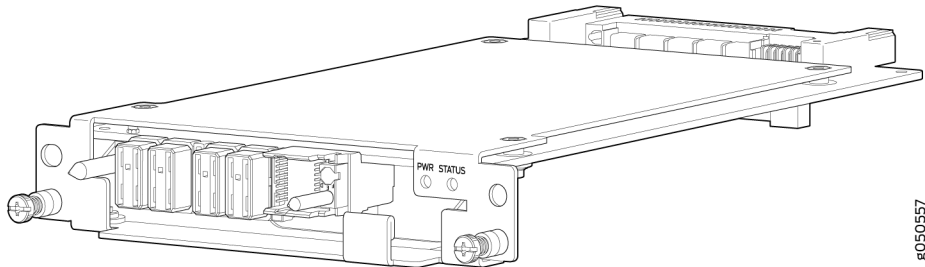
4. Tilt the top of the fan tray forward.
5. Using both hands, lift the fan tray out of the slot and rest it on a flat surface with the handles to the side.

Install a PTX10008 Fan Tray Controller

For each of the two fan trays, there is a fan tray controller. Each controller is a hot-removable and hot-insertable field-replaceable unit (FRU); you can remove and replace one fan tray controller while the router is running without turning off power to the router or disrupting routing functions. There are two models of fan tray controller for the PTX10008, JNP10008-FAN-CTRL and JNP10008-FTC2.

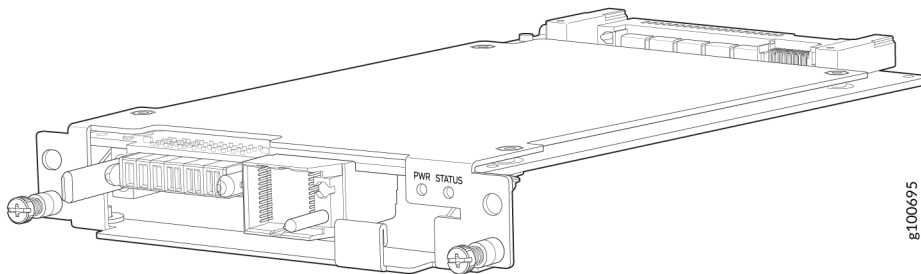
See [Figure 133 on page 356](#) and [Figure 134 on page 356](#).

Figure 133: JNP10008-FAN-CTRL



8050557

Figure 134: JNP10008-FTC2



8100695



CAUTION: Do not remove the fan tray controller unless you have a replacement controller available.

In order to install a fan tray controller, you must first remove the associated fan tray. With the fan tray removed, the fan tray controller is installed horizontally above the Switch Interface Boards (SIBs) at the top of the chassis.

Before you install a fan tray controller:

- Ensure that you have removed the associated fan tray and fan tray controller. See ["Remove a PTX10008 Fan Tray" on page 351](#) and ["Remove a PTX10008 Fan Tray Controller" on page 358](#).
- Ensure that you understand how to prevent ESD damage. See *Prevention of Electrostatic Discharge Damage*.
- Ensure that you have the following parts and tools available to install a fan tray controller into a PTX10008:

- Electrostatic discharge (ESD) grounding strap
- Replacement fan tray controller (JNP10008-FAN-CTRL or JNP10008-FTC2)
- A Phillips (+) screwdriver, number 1, for the captive screws

To install a fan tray controller:

1. Remove the replacement fan tray controller from the antistatic bag.
2. Carefully slide the fan tray controller into the fan tray controller slot until it is flush with the mounting holes. See [Figure 135 on page 357](#) and [Figure 136 on page 357](#).

Figure 135: Install a JNP10008-FAN-CTRL

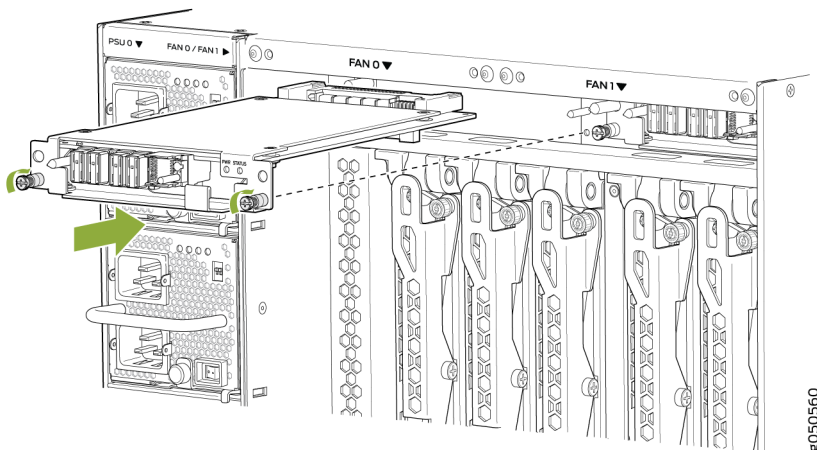
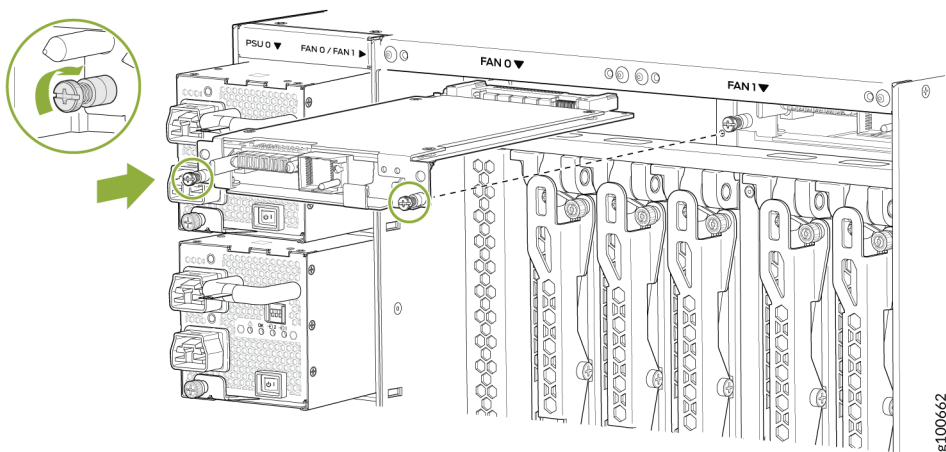


Figure 136: Install a JNP10008-FTC2



3. Using a Phillips screwdriver, tighten the captive screws for the fan tray controller.

4. Reinstall the fan tray. See ["Install a PTX10008 Fan Tray"](#) on page 348.

Remove a PTX10008 Fan Tray Controller

For each of the two fan trays, there is a fan tray controller. Each controller is a hot-removable and hot-insertable field-replaceable unit (FRU); you can remove and replace one fan tray controller while the router is running without turning off power to the router or disrupting routing functions. There are two models of fan tray controller:

- JNP10008-FAN-CTRL, which supports fan tray JNP10008-FAN
- JNP10008-FTC2, which supports fan tray JNP10008-FAN2

See [Figure 137 on page 358](#) for the JNP10008-FAN-CTRL and [Figure 138 on page 358](#) for the JNP10008-FTC2.

Figure 137: JNP10008-FAN-CTRL

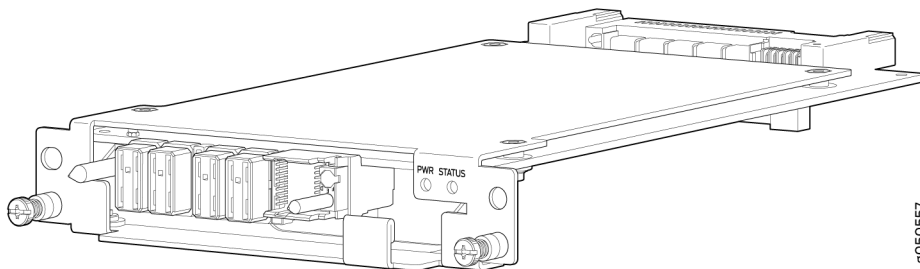
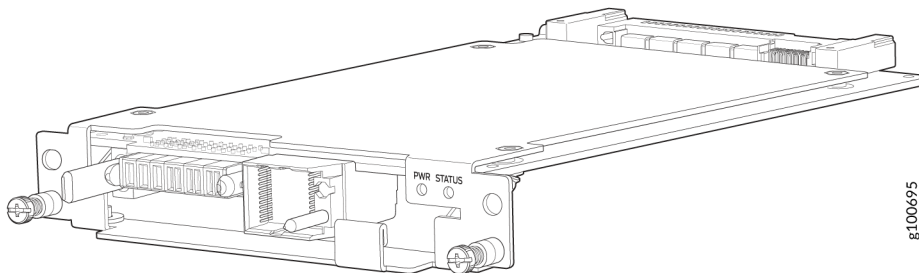


Figure 138: JNP10008-FTC2





CAUTION: Do not remove the fan tray controller unless you have a replacement controller available.

In order to access a fan tray controller, you must first remove the fan tray. With the fan tray removed, the fan tray controller is installed horizontally above the switch interface boards (SIBs) at the top of the chassis.

Before you remove a fan tray controller:

- Ensure that you understand how to prevent ESD damage. See *Prevention of Electrostatic Discharge Damage*.
- Ensure that you have the following parts and tools available to remove a fan tray controller from a PTX10008:
 - Electrostatic discharge (ESD) grounding strap
 - An electrostatic bag or an antistatic mat
 - Replacement fan tray controller
 - A Phillips (+) screwdriver, number 1, for the captive screws

Both models of fan controller are removed using the same procedure.

1. Remove the fan tray. See ["Remove a PTX10008 Fan Tray" on page 351](#).
2. Loosen the two captive screws on each side of the fan tray controller.
3. Grasp the fan tray controller and pull it straight out of the slot. See [Figure 139 on page 360](#) for the JNP10008-FAN-CTRL and [Figure 140 on page 360](#) for the JNP10008-FTC2.

Figure 139: Remove a JNP10008-FAN-CTRL

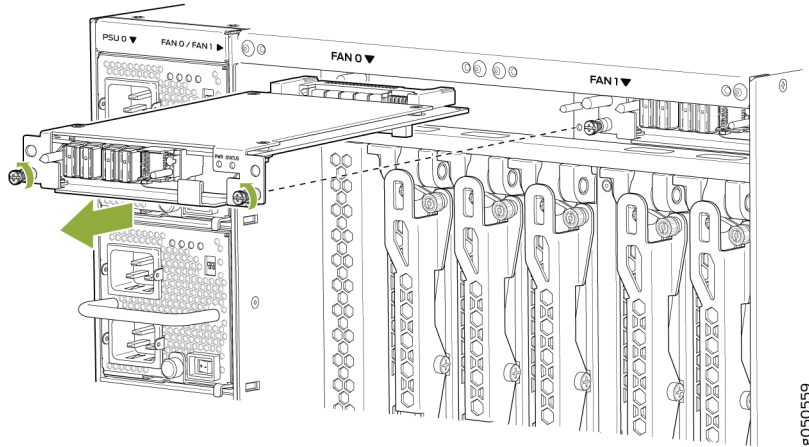
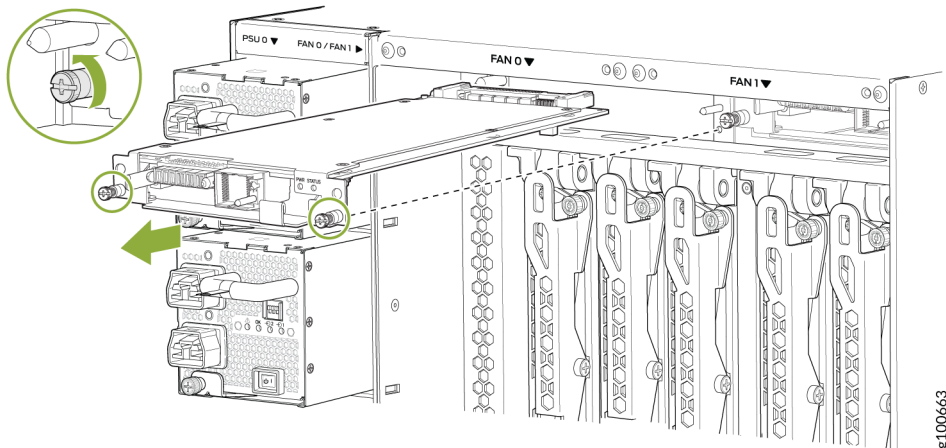


Figure 140: Remove a JNP10008-FTC2



4. Place the fan tray controller in an anti-static bag or on an antistatic mat.

RELATED DOCUMENTATION

[PTX10008 Cooling System and Airflow | 58](#)

[PTX10008 Field-Replaceable Units | 49](#)

Install and Remove PTX10008 Power System Components

IN THIS SECTION

- [Install a JNP10K-PWR-AC Power Supply | 362](#)
- [Troubleshooting an Unsupported Power Supply Unit on Junos OS Evolved | 367](#)
- [Remove a JNP10K-PWR-AC Power Supply | 369](#)
- [Install a JNP10K-PWR-AC2 Power Supply | 372](#)
- [Remove a JNP10K-PWR-AC2 Power Supply | 377](#)
- [Install a JNP10K-PWR-AC3 Power Supply | 380](#)
- [Remove a JNP10K-PWR-AC3 Power Supply | 388](#)
- [Install a JNP10K-PWR-DC Power Supply | 391](#)
- [Remove a JNP10K-PWR-DC Power Supply | 401](#)
- [Install a JNP10K-PWR-DC2 Power Supply | 405](#)
- [Remove a JNP10K-PWR-DC2 Power Supply | 416](#)

PTX10008 routers support both AC, DC, high voltage alternating current (HVAC), and high voltage direct current (HVDC) power supplies. To install and remove the power supplies in a PTX10008 router, read the following sections. All power supply models are hot-insertable and hot-removeable field-replaceable units (FRUs). You can install up to six power supplies in the rear of the chassis in the slots provided along the left side.

If you are upgrading a JNP10008-SF fabric system to use JNP10K-PWR-AC2 power supplies, also upgrade your fans and fan tray controllers to ensure the proper airflow. JNP10K-PWR-AC2 power supplies require JNP10008-FAN2 and JNP10008-FTC2 cooling systems.



CAUTION: Use the same type of power supply in all slots. Do not mix power supply models in the same chassis.

NOTE: See the heat symbol



. Wear heat-resistant hand gloves while accessing the fan tray and power supply.

Install a JNP10K-PWR-AC Power Supply

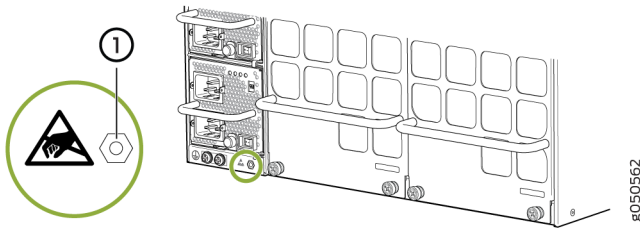
Before you install a JNP10K-PWR-AC power supply in the router:

- Ensure that you understand how to prevent ESD damage. See *Prevention of Electrostatic Discharge Damage*.
- If the AC power source outlets have a power router, set them to the off (O) position.
- Ensure that you have the following parts and tools available to install a JNP10K-PWR-AC power supply:
 - Electrostatic discharge (ESD) grounding strap
 - Phillips (+) screwdriver, number 1
 - Power cords appropriate for your geographical location. See "[PTX10008 Power Cables Specifications](#)" on page 222.
 - Power cord retainer clips

To install a JNP10K-PWR-AC power supply in a PTX10008:

1. Wrap and fasten one end of the ESD grounding strap around your bare wrist and connect the other end of the strap to an ESD point on the chassis. There is an ESD point located next to the protective earthing terminal and below **PSU 5** on the rear of the PTX10008 (see [Figure 141 on page 363](#)).

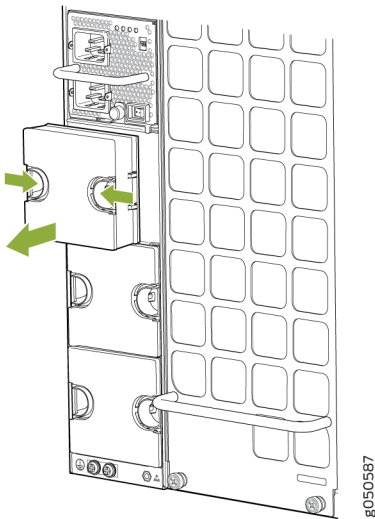
Figure 141: ESD Point on the Rear of the PTX10008



1– ESD point

2. If the power supply slot has a cover on it, insert your thumb and forefinger into the finger holes, squeeze and pull the cover out of the slot. Save the cover for later use. See [Figure 142 on page 363](#).

Figure 142: Remove the Power Supply Cover on a PTX10008

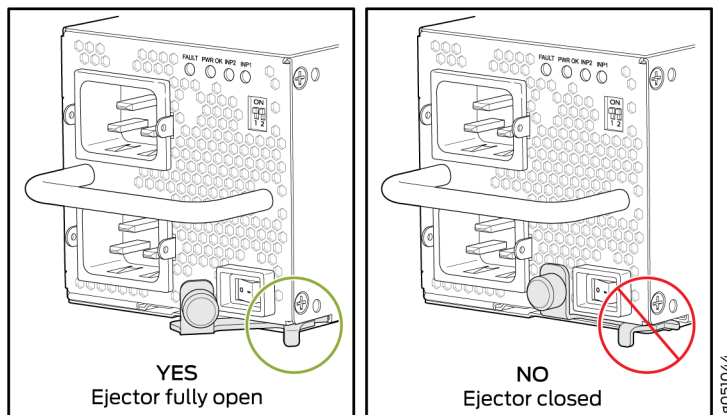
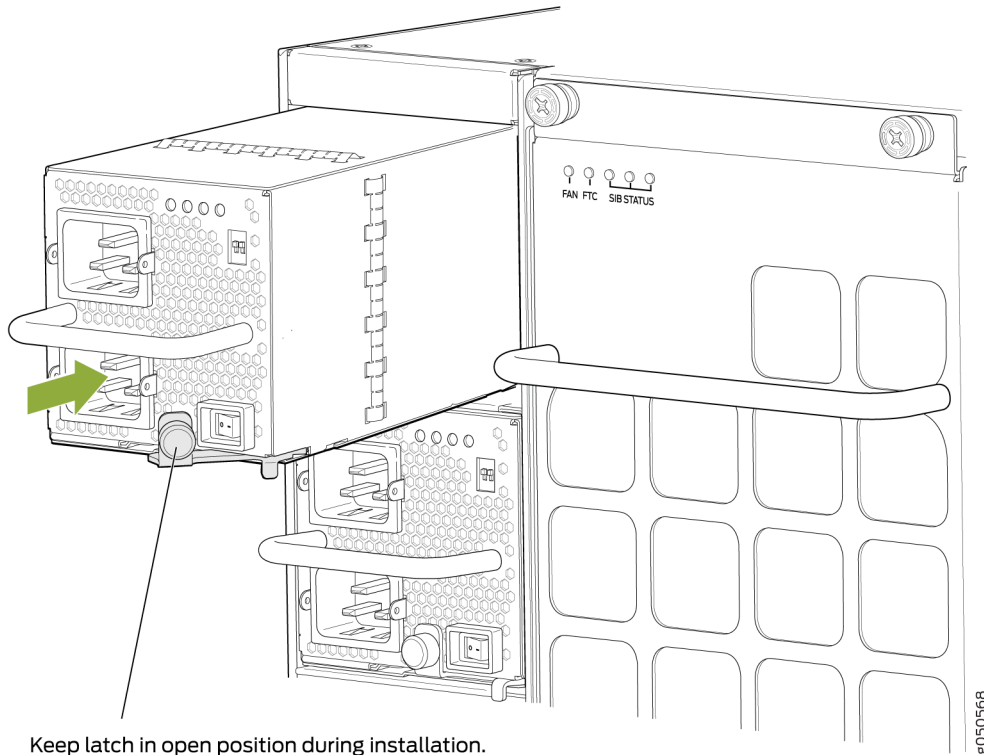


3. Taking care not to touch power supply connections, remove the power supply from its bag.
4. Peel back and remove the protective plastic wrap that covers all four sides of the power supply.
5. Ensure that the power switch is set to the standby (O) position. This switch turns off the output voltage; it does not interrupt AC supply.
6. Unscrew the captive screw in the counterclockwise direction by using your fingers or by using the Phillips (+) screwdriver, number 1.
7. Rotate the captive screw away from the faceplate of the power supply to release the latch.

NOTE: You can install the power supplies in any slot labeled **PSU 0** through **PSU 5** (top to bottom) on a PTX10008.

8. Using both hands, place the power supply in the power supply slot on the rear of the system.
9. Slide the power supply straight into the chassis until the power supply is fully seated in the slot. Ensure that the power supply faceplate is flush with any adjacent power supply faceplates or power supply covers (see [Figure 143 on page 365](#)).
10. Push the captive screw into the power supply faceplate. Ensure that the screw is seated inside the corresponding hole on the faceplate.
11. Tighten the captive screw by turning it clockwise by using your fingers or by using the Phillips (+) screwdriver, number 1. Do not overtighten—do not apply more than 7.3 lb-in (0.82 Nm) of torque to the screws. When the screw is completely tight, the latch locks into the router chassis.

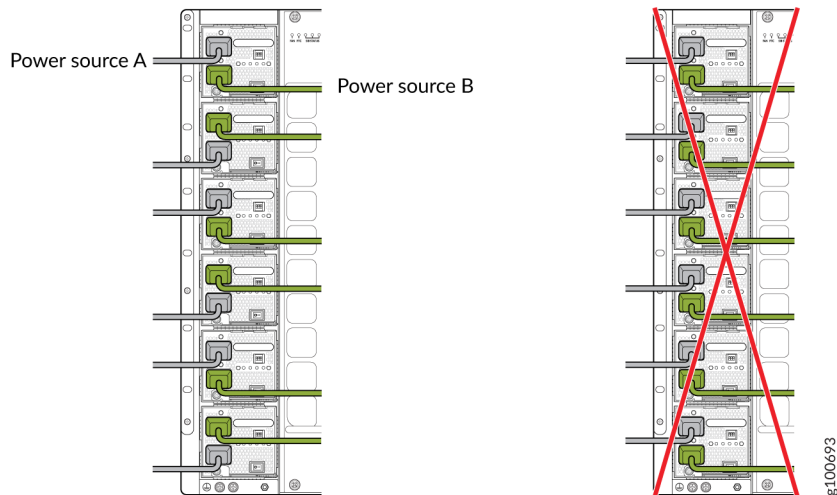
Figure 143: Install a JNP10K-PWR-AC Power Supply in a PTX10008



NOTE: Ensure that the ejector is fully open to avoid scratching the chassis.

12. Manually load-balance the power supplies as you attach each power cable to a dedicated AC power source outlet. To load-balance, route the power cables to alternate between power sources. The JNP10K-PWR-AC does not share power; all power comes into INP1 (lower receptacle) and uses INP2 (top receptacle) only at failover. See [Figure 144 on page 366](#).

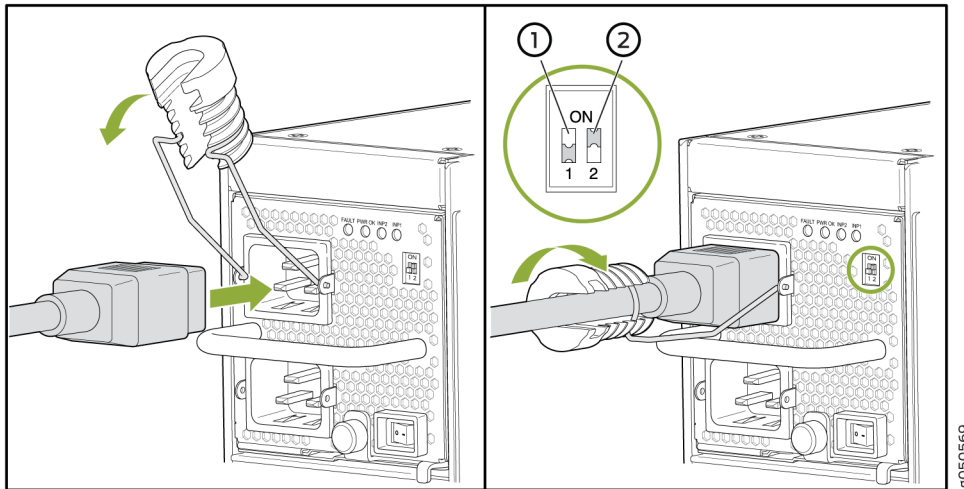
Figure 144: Proper Load Balancing for JNP10K-PWR-AC Power Cables on PTX10008



WARNING: Ensure that the power cords do not block access to router components or drape where people can trip on them. Always prevent cords and cables from being exposed to hot air exhaust by routing them away from the fan trays and power supplies at the rear of the chassis.

13. Squeeze the two sides of the power cord retainer clip and insert the ends of the clip into the holes in the bracket on each side of the AC appliance inlets on the AC power supply faceplate. See [Figure 145 on page 367](#).
14. Locate two power cords shipped with the router; the cords have plugs appropriate for your geographical location.
15. Insert the power cord coupler into the power supply.
Each AC power supply has two independent 16-A-rated AC inlets on the faceplate. Each inlet must be connected to a dedicated AC power feed to achieve 2n source redundancy. If redundancy is not a requirement, use the default input **INP1** for a single connection.
16. Fasten the cord retainer by lowering the clip over the cord and pushing the cord into the adjustment nut of the cord retainer. Rotate the nut until it is tight against the base of the cord. See [Figure 145 on page 367](#).

Figure 145: Power Cord and Retainer Clip



1– Enable switch for **INP1** appears as PS0 in output.

2– Enable switch for **INP2** appears as PS1 in output.



WARNING: Ensure that the power cords do not block access to router components or drape where people can trip on them.

17. If the AC power source outlets have a power switch, set them to the on (I) position.
18. Move the enable switches for input1 and input2 to the **ON** position.
19. Verify that the **INP1** and **INP2** LEDs on the power supply faceplate are lit and are on steadily.
20. Press the power switch to the on (I) position.

Troubleshooting an Unsupported Power Supply Unit on Junos OS Evolved

IN THIS SECTION

- Problem | 368
- Cause | 368
- Solution | 368

Problem

Description

When you partially insert a power supply unit (PSU) into a powered-up device, the PSU contacts the power connector, but fails to engage the short pin. Although the status LEDs light up without the short pin engagement, Junos OS Evolved ignores the PSU.

Cause

Without detecting the short pin engagement, Junos OS Evolved ignores the PSU, even if you push the PSU further in to engage the short pin. Junos OS Evolved checks the engagement of the short pin only thrice. The checks happen at an interval of 500 milliseconds (ms) after you partially insert the PSU. After the three attempts, Junos OS Evolved assumes that the PSU is not accessible and marks it as an unsupported PSU.

Solution

For Junos OS Evolved to recognize the PSU:

1. Unplug the PSU from the rear of the chassis by pulling out the PSU halfway to disconnect the backplane power connector.
2. Wait for 30 seconds.
3. Slide the PSU straight into the chassis until the PSU is fully seated in the slot. Ensure that the PSU faceplate is flush with any adjacent PSU faceplates or PSU covers.
 - The status LEDs light up.
4. Check whether the PSU is registered by Junos OS Evolved.
 - Issue the CLI **show chassis environment psm** command to check the status of the installed PSU. As shown in the sample output, the value **Online** in the row labeled **State** indicates that the PSU is functioning normally:

```
user@host> show chassis environment psm
PSM 2 status:
  State           Online
  Temperature     32 degrees C / 89 degrees F
  Temperature 1   34 degrees C / 93 degrees F
  Temperature 2   35 degrees C / 95 degrees F
  Temperature 3   44 degrees C / 111 degrees F
```

```

Fans                                OK
AC Input A0                         OK
AC Input A1                         OK
AC Input B0                         OK
AC Input B1                         OK
Check Input A0 Alarm                No
Check Input A1 Alarm                No
Check Input B0 Alarm                No
Check Input B1 Alarm                No
DC Output                           OK
Hours Used                           506
Firmware Version                    Pri MCU 101.101.101.101
                                      Sec MCU 102.102
                                      Com MCU 101
                                      led MCU 100
Fan 1                               14304
Fan 2                               15648
HVDC Mode                           All Inputs are AC
Health check Information:
  Status:                            Health Check Passed
  Last Result:                        Passed
  Last Execution:                     2024-01-31 06:58:29 UTC
  Next Scheduled Run:                 2024-02-07 06:58:29 UTC

```

Remove a JNP10K-PWR-AC Power Supply

Before you remove a JNP10K-PWR-AC power supply from the chassis:

- Ensure that you understand how to prevent ESD damage. See *Prevention of Electrostatic Discharge Damage*.
- Ensure that you have the following parts and tools available to remove a JNP10K-PWR-AC power supply from a PTX10008 router:
 - Electrostatic discharge (ESD) grounding strap
 - Phillips (+) screwdriver, number 1
 - Heat-protective gloves
 - Replacement power supply or a cover for the power supply slot



CAUTION: Do not leave the power supply slot empty for a long time while the router is operational. Either replace the power supply promptly or install a cover over the empty slot.

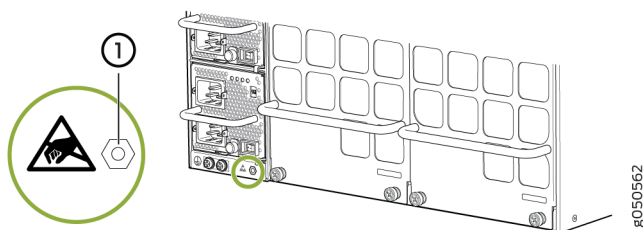


CAUTION: Before you remove a power supply, ensure that you have power supplies sufficient to power the router left in the chassis. See "[PTX10008 Power Planning for JNP10008-SF3 Switch Fabric](#)" on page 244 or "[PTX10008 Power Planning for JNP10008-SF Switch Fabric](#)" on page 207.

To remove a JNP10K-PWR-AC power supply from a PTX10008 router:

1. Wrap and fasten one end of the ESD grounding strap around your bare wrist and connect the other end of the strap to an ESD point on the chassis. There is an ESD point located next to the protective earthing terminal and below **PSU 5** on the rear of the PTX10008 (see [Figure 146 on page 370](#)).

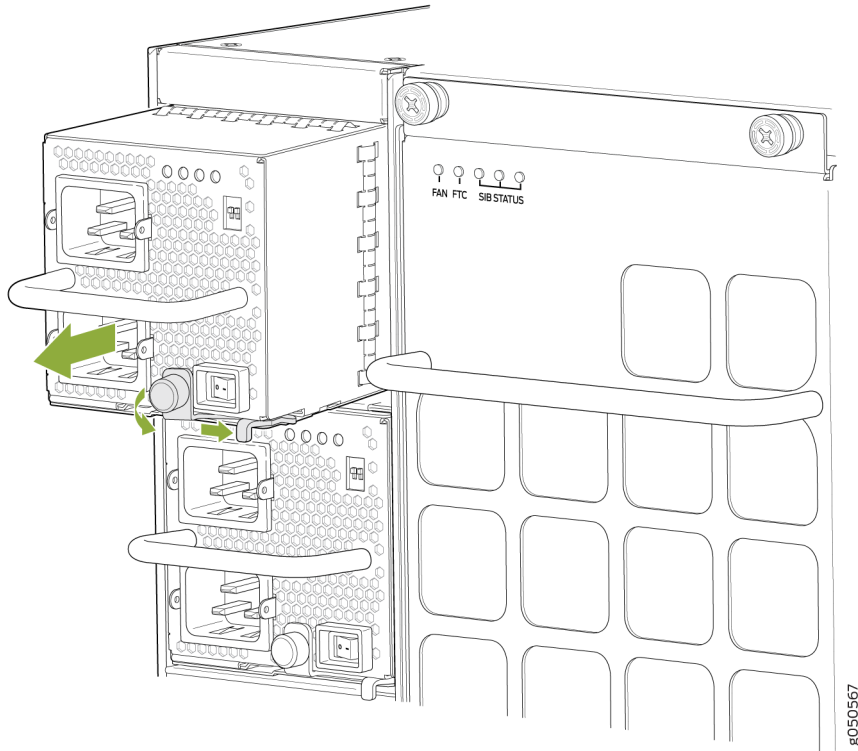
Figure 146: ESD Point on Rear of the PTX10008



1– ESD point

2. Flip the power switch (○ and |) next to the appliance inlet on the power supply to the standby position (○).
3. Disconnect power from the router by performing one of the following tasks:
 - If the AC power source outlets have a power switch, set them to the off (○) position.
 - If the AC power source outlets do not have a power switch, gently pull the plug end of the power cords connected to the power source outlets out of the outlets.
4. Remove the power cords from the AC appliance inlets on the AC power supply faceplate.
5. Turn the adjustment nut of the power cord retainers counterclockwise till you can see the power cord. Pull the power cord from the slot in the adjustment nuts.
6. Unscrew the captive screw counterclockwise by using your fingers or by using the Phillips (+) screwdriver, number 1. See [Figure 147 on page 371](#).

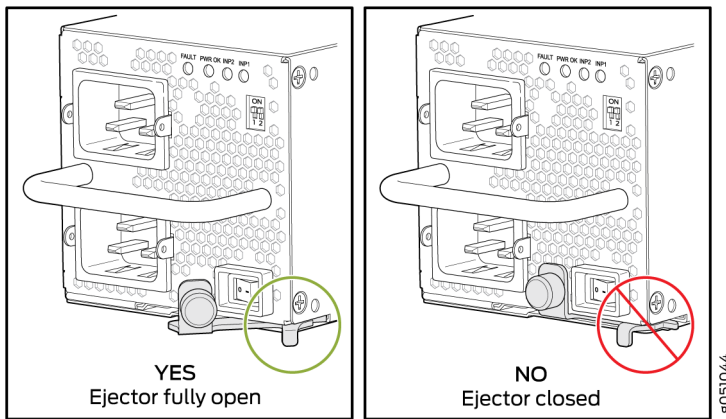
Figure 147: Remove a JNP10K-PWR-AC Power Supply from a PTX10008



- 7. Rotate the captive screw away from the faceplate of the power supply to release the latch.

NOTE: Ensure that the ejector is fully open to avoid scratching the chassis, see [Figure 148 on page 371](#).

Figure 148: Open Power Supply Ejector



8. Taking care not to touch the power supply output connections, pins, leads, or solder connections, place one hand under the power supply to support it. Grasp the power supply handle with your other hand and pull the power supply completely out of the chassis.



CAUTION: Do not bump the output connections. If the connection hits a solid object, it could damage the power supply.



CAUTION: See the heat symbol



. The power supply surfaces are hot. Allow a few minutes for the power supply to cool by pulling the power supply halfway out of the chassis, or wear protective, heat-resistant gloves while removing the power supply.

9. If you are not replacing the power supply, install the cover over the slot. To install the cover, insert your thumb and forefinger into the finger holes of the cover, squeeze to retract the spring latches, and place the cover in the slot. Do not run the chassis without a power supply or cover in place.

Install a JNP10K-PWR-AC2 Power Supply



CAUTION: Use the same type of power supply in all slots. Do not mix power supply models in a production chassis. The only time you are allowed to have two models concurrently running in a system is when you are in the process of swapping out all JNP10K-PWR-AC power supplies with all JNP10K-PWR-AC2 power supplies.



WARNING: Protect yourself from severe burns by wearing heat-protective gloves when removing a running JNP10K-PWR-AC2 power supply from the chassis. The power supply can reach temperatures between 158°F and 176°F (70°C to 80°C) under running conditions.

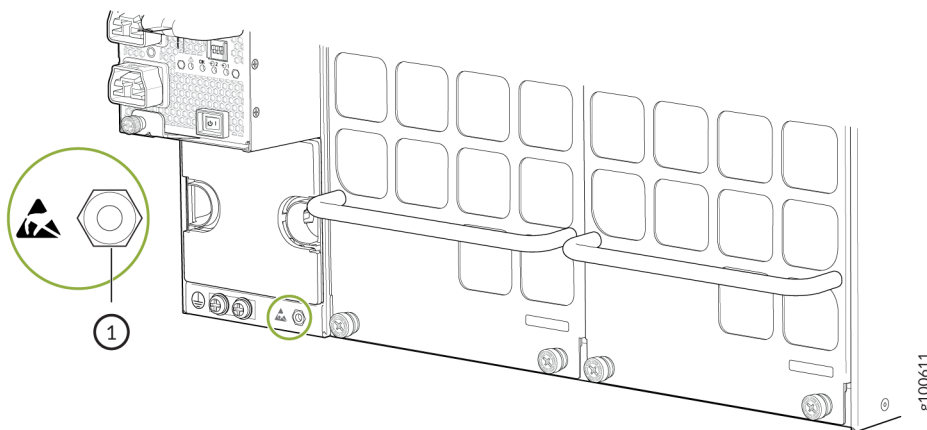
Before you install a JNP10K-PWR-AC2 power supply in the chassis:

- Ensure that you have followed all safety warnings and cautions.
- Ensure that you understand how to prevent ESD damage. See *Prevention of Electrostatic Discharge Damage*.
- If the AC or DC power source outlets have a power switch, set them to off (O). Ensure that you have the following parts and tools available to install a JNP10K-PWR-AC2 power supply:
 - Electrostatic discharge (ESD) grounding strap
 - Phillips (+) screwdriver, number 1
 - Power cables appropriate for your geographical location (for low-voltage installations) or input amperage (for high-voltage installations). See "[PTX10008 Power Cables Specifications](#)" on page [222](#). HVAC and HVDC connectors and lugs must be installed by a qualified electrician before installation.

To install a JNP10K-PWR-AC2 power supply in a PTX10008:

1. Wrap and fasten one end of the ESD grounding strap around your bare wrist and connect the other end of the strap to an ESD point on the chassis. There is an ESD point located next to the protective earthing terminal and below **PSU5** on the rear of the PTX10008 (see [Figure 149 on page 373](#)).

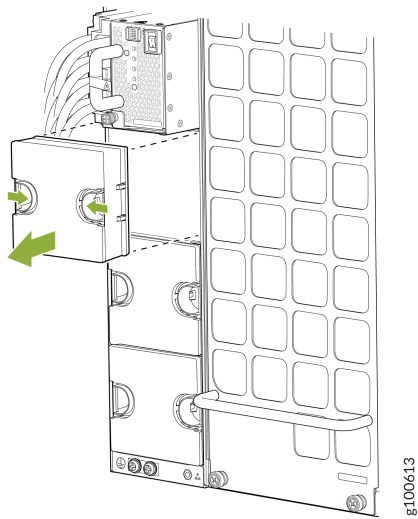
Figure 149: ESD Point on the Rear of the PTX10008



1– ESD point

2. If the power supply slot has a cover on it, insert your thumb and forefinger into the finger holes, squeeze, and pull the cover out of the slot. Save the cover for later use. See [Figure 150 on page 374](#) for the removal on a PTX10008.

Figure 150: Remove the Power Supply Cover on a PTX10008

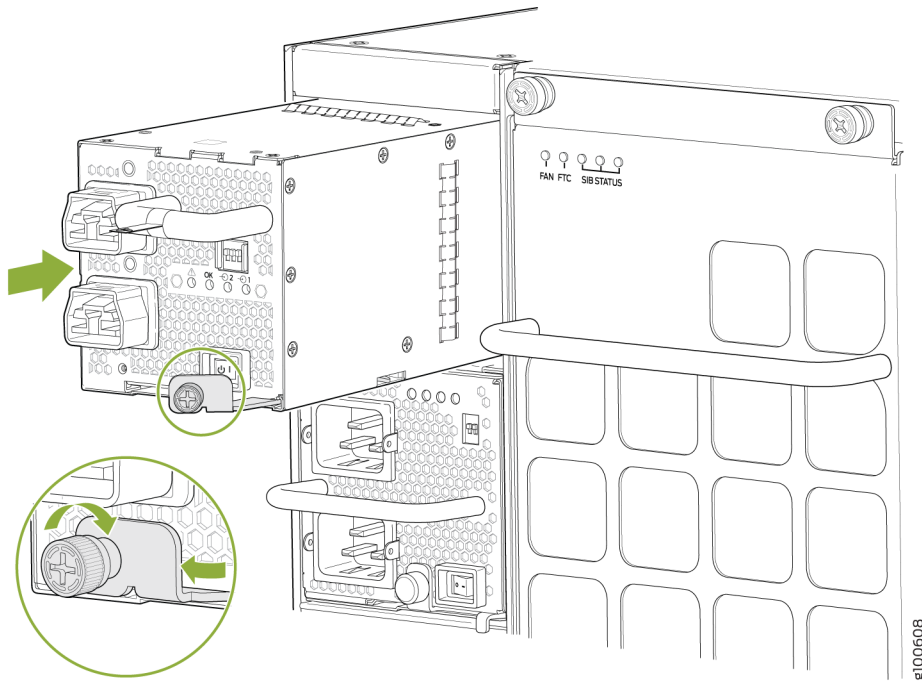


3. Taking care not to touch power supply connections, remove the power supply from its bag.
4. Peel back and remove the protective plastic wrap that covers all four sides of the power supply.
5. Ensure that the power switch is set to the standby (O) position. This switch turns off the output voltage; it does not interrupt input power.
6. Unscrew the captive screw in the counterclockwise direction by using your fingers or by using the Phillips (+) screwdriver, number 1.
7. Rotate the captive screw away from the faceplate of the power supply to release the latch.

NOTE: You can install the power supplies in any slot labeled **PSU 0** through **PSU 5** (top to bottom) on a PTX10008.

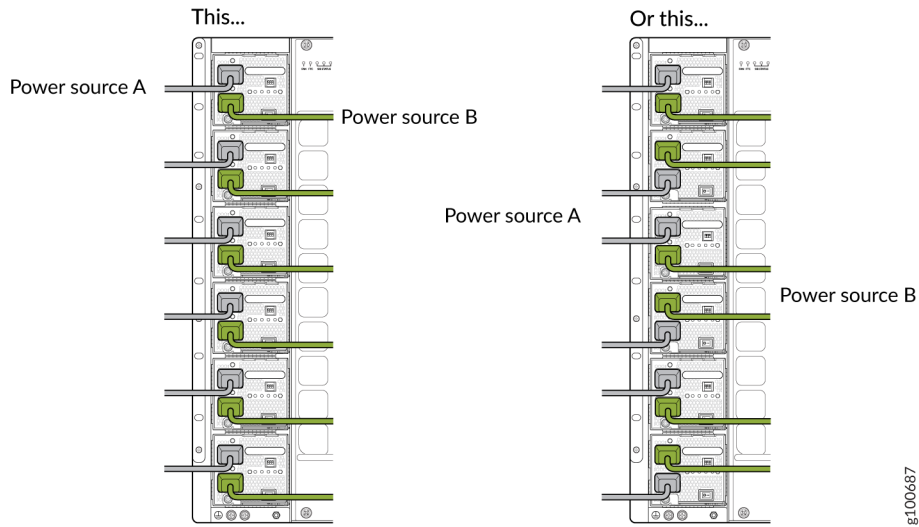
8. Using both hands, place the power supply in the power supply slot on the rear of the system. Slide the power supply straight into the chassis until the power supply is fully seated in the slot. Ensure that the power supply faceplate is flush with any adjacent power supply faceplates or power supply covers (see [Figure 151 on page 375](#)).

Figure 151: Install a JNP10K-PWR-AC2 Power Supply in a PTX10008



9. Push the captive screw into the power supply faceplate. Ensure that the screw is seated inside the corresponding hole on the faceplate.
10. Tighten the captive screw by turning it clockwise by using your fingers or by using the Phillips (+) screwdriver, number 1. Do not overtighten—do not apply more than 7.3 lb-in (0.82 Nm) of torque to the screws. When the screw is completely tight, the latch locks into the router chassis.
11. Attach each power cable to a dedicated power source (A and B). The JNP10K-PWR-AC2 requires that each power supply be connected to a separate source. See [Figure 152 on page 376](#) for some possible cabling combinations for PTX10008.

Figure 152: Proper Load Balancing for JNP10K-PWR-AC2 Power Cables on a PTX10008



12. For each power cable, insert the end of the cable with the Anderson connector into the JNP10K-PWR-AC2 power supply. The connector snaps and locks the cable into position.



WARNING: Ensure that the power cords do not block access to router components or drape where people can trip on them.

13. If the AC or DC power source outlets have a power switch, set them to the on (I) position.
14. Set the three DIP switches to set the inputs and whether the power supply is running at 3000 W, 5000 W, or 5500 W. See [Table 122 on page 376](#).

Set both enable switches to the **on** position when using both power source inputs. When not using source redundancy, set the unused source to the off (O) position. The LED turns red and indicates an error if a source input is not in use and the enable switch is on (I).

Table 122: Set the JNP10K-PWR-AC2 DIP Switches

Switch	State	Description
1	On	INP0 is present.
	Off	INP0 is not present.
2	On	INP1 is present.

Table 122: Set the JNP10K-PWR-AC2 DIP Switches (Continued)

Switch	State	Description
	Off	INP1 is not present.
3	On	Enabled for 30-A feed; 5000 W for single feed, 5500 W for dual feeds.
	Off	Enabled for 20-A feed; power supply capacity is 3000 W.

15. Verify that the **INP1** and **INP2** LEDs on the power supply faceplate are lit and are on steadily.
16. Press the power switch to the on (I) position.

Remove a JNP10K-PWR-AC2 Power Supply

Before you remove an JNP10K-PWR-AC2 power supply from the chassis:

- Ensure that you understand how to prevent ESD damage. See *Prevention of Electrostatic Discharge Damage*.
- Ensure that you have the following parts and tools available to remove a JNP10K-PWR-AC2 power supply from a PTX10008 router:
 - Heat-protective gloves able to withstand temperatures of 158° F (70° C)
 - Electrostatic discharge (ESD) grounding strap
 - Phillips (+) screwdriver, number 1
 - Replacement power supply or a cover for the power supply slot



WARNING: Protect yourself from severe burns by wearing heat-protective gloves when removing a working JNP10K-PWR-AC2 power supply from the chassis. These power supplies can reach temperatures between 158° F to 176° F (70° C to 80° C) under running conditions.



CAUTION: Before you remove a power supply, ensure that you have power supplies sufficient to power the router left in the chassis. See ["PTX10008 Power Planning for](#)

[JNP10008-SF3 Switch Fabric" on page 244](#) or ["PTX10008 Power Planning for JNP10008-SF Switch Fabric" on page 207.](#)

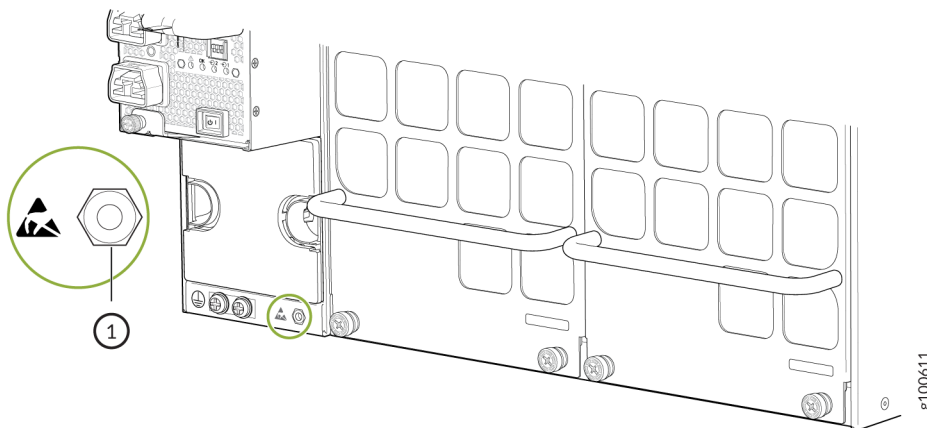


CAUTION: Do not leave the power supply slot empty for a long time while the router is operational. Either replace the power supply promptly or install a cover over the empty slot.

To remove a JNP10K-PWR-AC2 power supply from a PTX10008 router:

1. Wrap and fasten one end of the ESD grounding strap around your bare wrist and connect the other end of the strap to an ESD point on the chassis. There is an ESD point located next to the protective earthing terminal and below **PSU 5** on the rear of the PTX10008 (see [Figure 153 on page 378](#)).

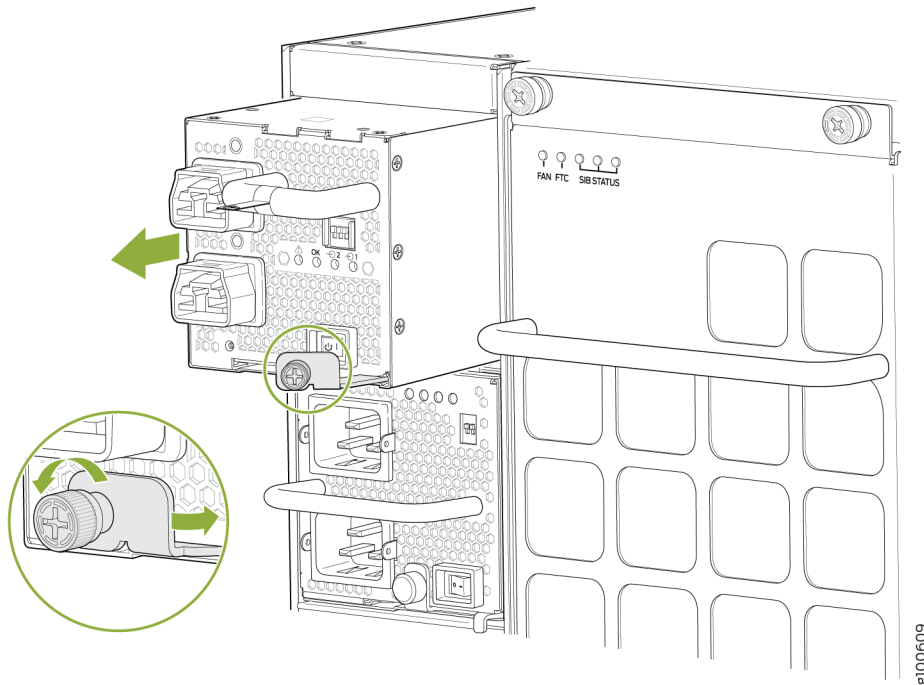
Figure 153: ESD Point on the Rear of the PTX10008



1– ESD point

2. Flip the power (I) switch next to the appliance inlet on the power supply to the standby position (O).
3. If the AC or DC power source outlets have a power switch, set them to the off (O) position.
4. Disconnect the Anderson connectors from each input on the JNP10K-PWR-AC2 power supply faceplate.
5. Unscrew the captive screw counterclockwise by using your fingers or by using the Phillips (+) screwdriver, number 1. See [Figure 154 on page 379](#).

Figure 154: Remove a JNP10K-PWR-AC2 Power Supply from a PTX10008



6. Rotate the captive screw away from the faceplate of the power supply to release the latch.
7. Wear heat-protective gloves before removing the power supply from the chassis.
8. Taking care not to touch the power supply output connections, pins, leads, or solder connections, place one hand under the power supply to support it. Grasp the power supply handle with your other hand and pull the power supply completely out of the chassis.



CAUTION: Do not bump the output connections. If the connection hits a solid object, it could damage the power supply.

9. Place the JNP10K-PWR-AC2 power supply on an antistatic surface to completely cool before placing the power supply in an antistatic bag for storage.
10. If you are not replacing the power supply, install the cover over the slot. To install the cover, insert your thumb and forefinger into the finger holes of the cover, squeeze to retract the spring latches, and place the cover in the slot. Do not run the chassis without a power supply or cover in place.

Install a JNP10K-PWR-AC3 Power Supply



CAUTION: Use the same type of power supply in all slots. Do not mix power supply models in a production chassis. The only time you are allowed to have two models concurrently running in a system is when you are in the process of swapping out all JNP10K-PWR-AC power supplies with all JNP10K-PWR-AC3 power supplies.



WARNING: Protect yourself from severe burns by wearing heat-protective gloves when removing a running JNP10K-PWR-AC3 power supply from the chassis. The power supply can reach temperatures between 158° F to 176° F (70° C to 80° C) under running conditions.

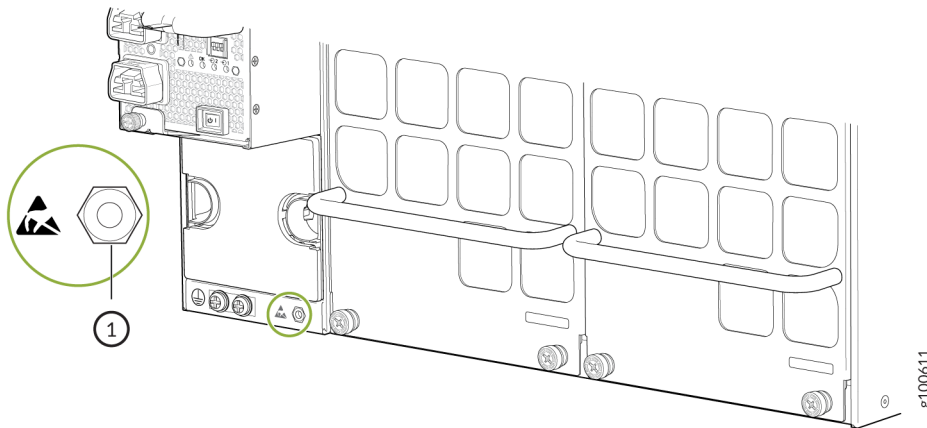
Before you install a JNP10K-PWR-AC3 power supply in the chassis:

- Ensure that you have followed all safety warnings and cautions.
- Ensure that you understand how to prevent ESD damage. See "[Prevention of Electrostatic Discharge Damage](#)" on page 509.
- If the AC power source outlets have a power switch, set them to the off (O) position. Ensure that you have the following parts and tools available to install the JNP10K-PWR-AC3 power supply:
 - Electrostatic discharge (ESD) grounding strap
 - Phillips (+) screwdriver, number 1
 - Power cables appropriate for your geographical location (for low-voltage installations) or input amperage (for high-voltage installations). See "[JNP10K-PWR-AC3 Power Cable Specifications](#)" on page 255.

To install a JNP10K-PWR-AC3 power supply in a PTX10008:

1. Wrap and fasten one end of the ESD grounding strap around your bare wrist and connect the other end of the strap to an ESD point on the chassis. There is an ESD point located next to the protective earthing terminal and below **PSU 5** on the rear of the PTX10008 (see [Figure 186](#) on page 418).

Figure 155: ESD Point on the Rear of the PTX10008



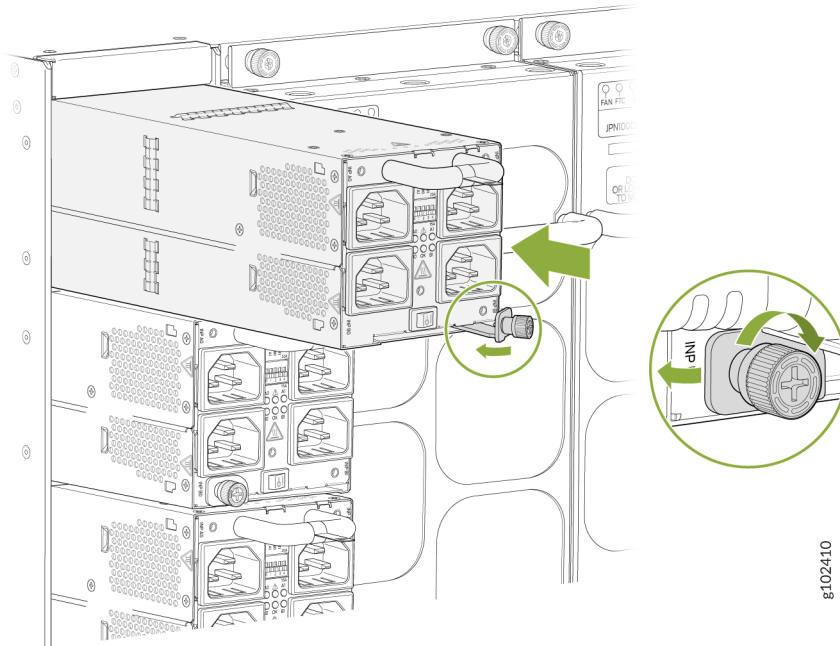
1– ESD point

2. Taking care not to touch power supply connections; remove the power supply from its bag.
3. Ensure that the power switch is set to the standby (O) position. This switch turns off the output voltage; it doesn't interrupt input power.
4. Unscrew the captive screw in the counterclockwise direction by using the Phillips (+) screwdriver, number 1.
5. Rotate the captive screw away from the faceplate of the power supply to release the latch.

NOTE: You can install the power supplies in any slot labeled **PSU 0** through **PSU 5** (top to bottom) on a PTX10008.

6. Using both hands, place the power supply in the power supply slot on the rear of the system. Slide the power supply straight into the chassis until the power supply is fully seated in the slot. Ensure that the power supply faceplate is flush with any adjacent power supply faceplates or power supply covers (see "[Install a JNP10K-PWR-AC3 Power Supply](#)" on page 380).

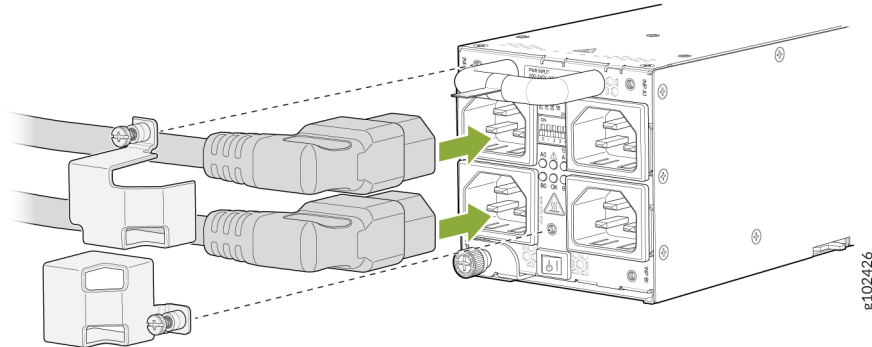
Figure 156: Install a JNP10K-PWR-AC3



8102410

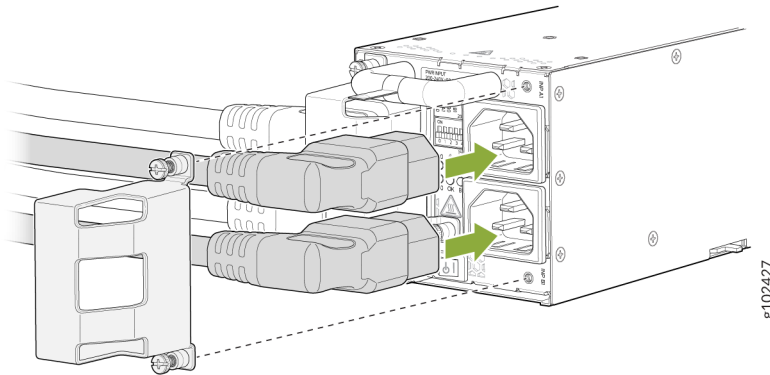
7. Push the captive screw into the power supply faceplate. Ensure that the screw is seated inside the corresponding hole on the faceplate.
8. Tighten the captive screw by turning it clockwise by using the Phillips (+) screwdriver, number 1. When the screw is completely tight, the latch locks into the router chassis.
9. Attach each power cable to a dedicated power source (A0, B0, A1, and B1). The JNP10K-PWR-AC3 only requires that each power supply be connected to a separate source.
 - a. When installing the right angle power cords, the left column of inputs (A0 and B0) should be connected first. After connecting the A0 and/or B0 inputs, secure the plugs using the retainer (SKU#540-175625) for the A0 plug and retainer (SKU#540-175626) for the B0 plug. The retainers are attached to the PSU faceplate with a single captive fastener using a #1 Philips screws drive. See [Figure 157 on page 383](#).

Figure 157: Plug Retainers for A0 and B0 Inputs



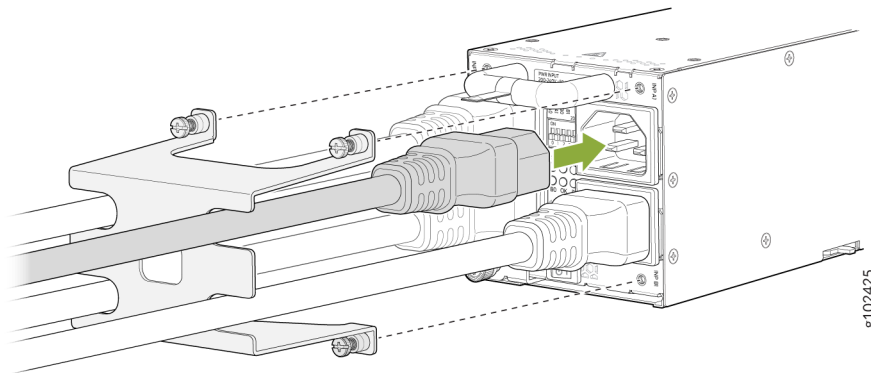
- b. Next connect the right column of inputs (A1 and B1). After connecting the A1 and/or B1 inputs, secure the plugs using the retainers (SKU#540-175627). The right column plug retainer is attached to the PSU faceplate with two captive screws using a #1 Philips screwdriver. See [Figure 158 on page 383](#).

Figure 158: Plug Retainers for A1 and B1 Inputs



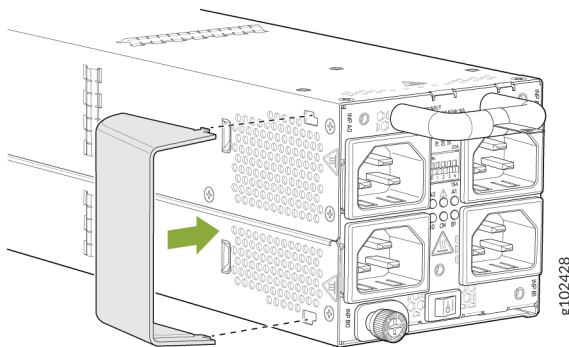
- a. If you want to use straight power cords, you may connect the straight power cords in any order. After connecting the straight power cords, secure the plugs with the retainer (SKU#540-175624). The retainer is attached to the PSU faceplate with three captive fasteners using a #1 Philips screw driver. See [Figure 159 on page 384](#)

Figure 159: Connecting Straight Power Cords



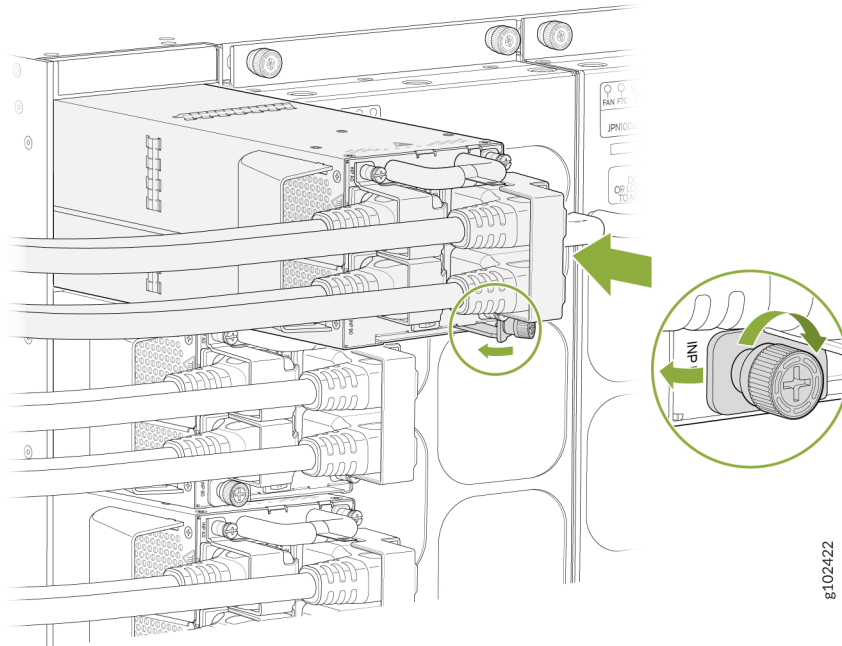
NOTE: Installing baffle is optional, and only to be used when you want to redirect the air flow from the left side of the PSU to the rear of the router. This ensures NEBs compliance. The baffle should be installed before the power supply is inserted into the router. See [Figure 160 on page 384](#).

Figure 160: Installing Baffle in JNPR10K-PWR-AC3



- For each power cable, insert the end of the cable with C21 connector into the JNP10K-PWR-AC3 power supply. Use the retainers to keep the power cord in its place in the power supply. See [Figure 161 on page 385](#).

Figure 161: Installing a JNPR10K-PWR-AC3 using RA Power Cords with Baffle



WARNING: Ensure that the power cords do not block access to router components or drape where people can trip on them.

11. If the AC power source outlets have a power switch, set them to the On (I) position.
12. Set the five DIP switches to set the inputs and whether the power supply is running at 3000 W, 6000 W, or 7800 W. See [Table 123 on page 385](#).

Table 123: DIP Switch Settings for JNP10K-PWR-AC3 Power Supply

INP-A0 (Switch 0)	INP-A1 (Switch 1)	INP-B0 (Switch 2)	INP-B1 (Switch 3)	Switch 4 (High Input 20 A/ Low Input 15 A)	Output Power
15-A					
Off	Off	Off	On	Off (15 A)	2500 W
Off	Off	On	Off	Off (15 A)	2500 W

Table 123: DIP Switch Settings for JNP10K-PWR-AC3 Power Supply (Continued)

INP-A0 (Switch 0)	INP-A1 (Switch 1)	INP-B0 (Switch 2)	INP-B1 (Switch 3)	Switch 4 (High Input 20 A/ Low Input 15 A)	Output Power
Off	Off	On	On	Off (15 A)	5000 W
Off	On	Off	Off	Off (15 A)	2500 W
Off	On	Off	On	Off (15 A)	5000 W
Off	On	On	On	Off (15 A)	7500 W
Off	On	On	Off	Off (15 A)	5000 W
On	Off	Off	Off	Off (15 A)	2500 W
On	Off	Off	On	Off (15 A)	5000 W
On	Off	On	Off	Off (15 A)	5000 W
On	Off	On	On	Off (15 A)	7500 W
On	On	Off	Off	Off (15 A)	5000 W
On	On	Off	On	Off (15 A)	7500 W
On	On	On	Off	Off (15 A)	7500 W
On	On	On	On	Off (15 A)	7800 W
20-A					
Off	Off	Off	On	On (20 A)	3000 W

Table 123: DIP Switch Settings for JNP10K-PWR-AC3 Power Supply (Continued)

INP-A0 (Switch 0)	INP-A1 (Switch 1)	INP-B0 (Switch 2)	INP-B1 (Switch 3)	Switch 4 (High Input 20 A/ Low Input 15 A)	Output Power
Off	Off	On	Off	On (20 A)	3000 W
Off	Off	On	On	On (20 A)	6000 W
Off	On	Off	Off	On (20 A)	3000 W
Off	On	Off	On	On (20 A)	6000 W
Off	On	On	Off	On (20 A)	6000 W
Off	On	On	On	On (20 A)	7800 W
On	Off	Off	Off	On (20 A)	3000 W
On	Off	Off	On	On (20 A)	6000 W
On	Off	On	Off	On (20 A)	6000 W
On	Off	On	On	On (20 A)	7800 W
On	On	Off	Off	On (20 A)	6000 W
On	On	Off	On	On (20 A)	7800 W
On	On	On	Off	On (20 A)	7800 W
On	On	On	On	On (20 A)	7800 W

- 13.** If the AC power source outlet has a power switch, turn it off before plugging in the AC power cord to the power outlet.

14. Verify that the **INP A0**, **INP A1**, **INP B0**, and **INP B1** LEDs on the power supply faceplate are lit and are On steadily.
15. Press the power switch to the On (I) position.

Remove a JNP10K-PWR-AC3 Power Supply

Before you remove a JNP10K-PWR-AC3 power supply from the chassis:

- Ensure that you understand how to prevent ESD damage. See "[Prevention of Electrostatic Discharge Damage](#)" on page 509.
- Ensure that you have the following parts and tools available:
 - Heat-protective gloves able to withstand temperatures of 158°F (70°C)
 - Electrostatic discharge (ESD) grounding strap
 - Phillips (+) screwdriver, number 1
 - Replacement power supply or a cover for the power supply slot



WARNING: Protect yourself from severe burns by wearing heat-protective gloves when removing a working JNP10K-PWR-AC3 power supply from the chassis. These power supplies can reach temperatures between 158°F and 176°F (70°C to 80°C) under running conditions.



CAUTION: Before you remove a power supply, ensure that you have power supplies sufficient to power the router left in the chassis. See "[Power Requirements for PTX10008 Components in a JNP10008-SF Fabric](#)" on page 209.

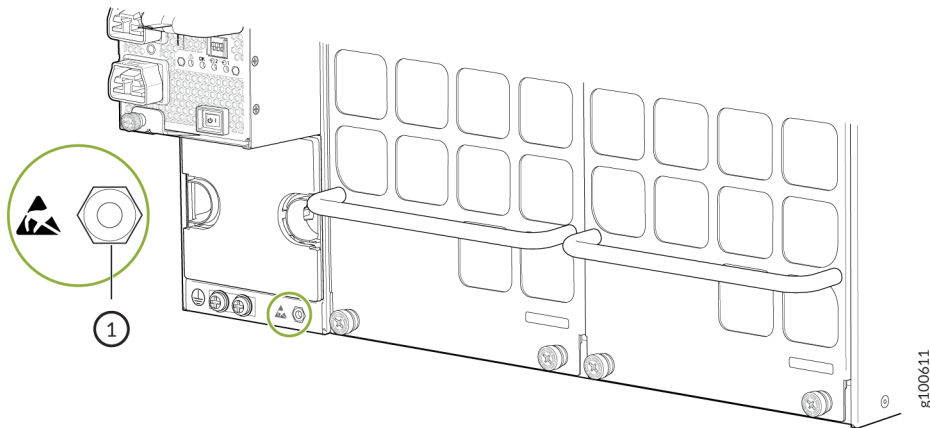


CAUTION: Do not leave the power supply slot empty for a long time while the router is operational. Either replace the power supply promptly or install a ABPM or a cover over the empty slot.

To remove a JNP10K-PWR-AC3 power supply from a PTX10008 router:

1. Wrap and fasten one end of the ESD grounding strap around your bare wrist and connect the other end of the strap to an ESD point on the chassis. There is an ESD point located next to the protective earthing terminal and below **PSU 5** on the rear of the PTX10008 (see [Figure 186](#) on page 418).

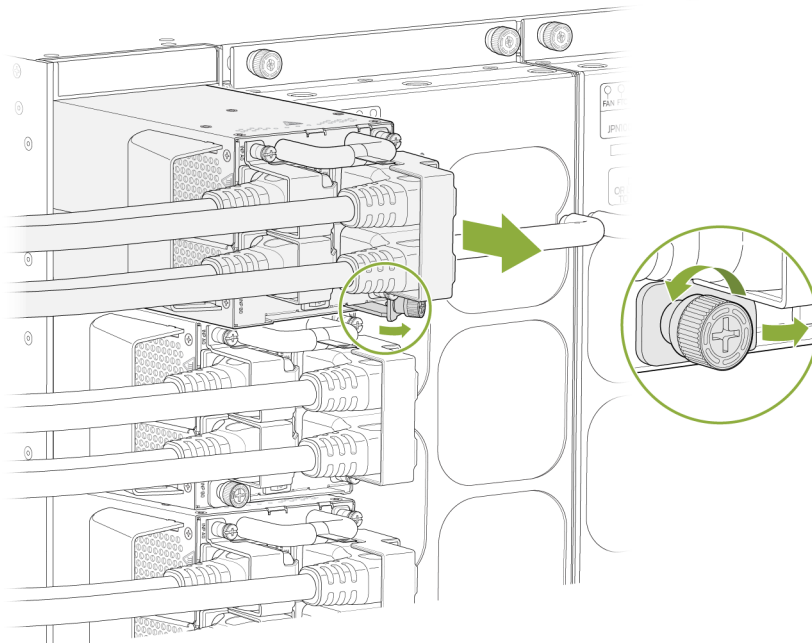
Figure 162: ESD Point on the Rear of the PTX10008



1– ESD point

2. Flip the power (I) switch next to the appliance inlet on the power supply to the standby position (O).
3. If the AC power source outlets have a power switch, set them to the off (O) position.
4. Remove the retainers using a #1 Philips screw driver and detach the power cords from the PSU.

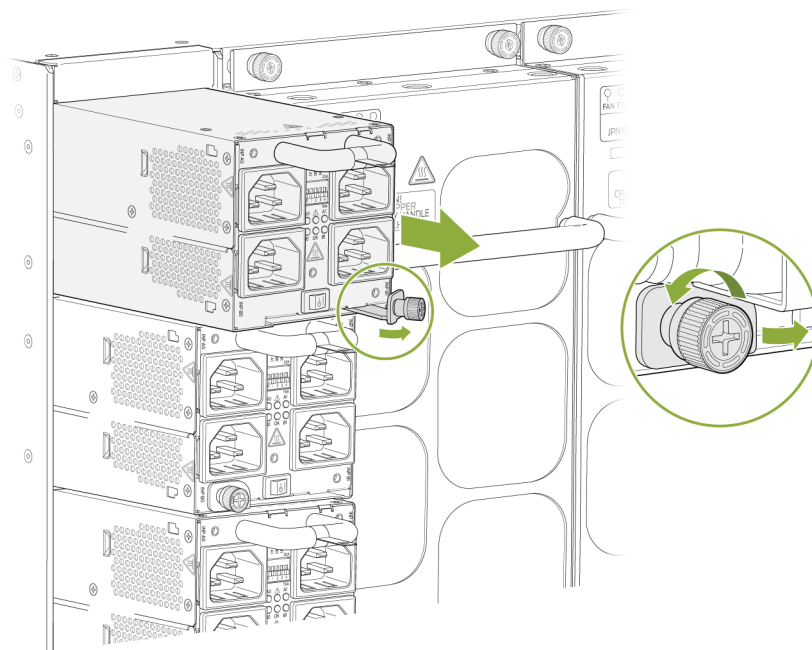
Figure 163: Detach the Power Cords from JNP10K-PWR-AC3 Power Supply



5. Unscrew and remove the retainers, remove the power cord from the PSU, and disconnect the IEC320-C21 connectors from each input on the JNP10K-PWR-AC3 power supply faceplate.
6. Unscrew the captive screw counterclockwise by using the Phillips (+) screwdriver, number 1. See [Figure 164 on page 390](#).

NOTE: Ensure that the ejector is fully open to avoid scratching the chassis.

Figure 164: Remove a JNP10K-PWR-AC3 Power Supply from a PTX10008



7. Rotate the captive screw away from the faceplate of the power supply to release the latch.
8. Wear heat protective gloves before you remove the power supply from the chassis.



9. Taking care not to touch the power supply output connections, pins, leads, or solder connections, place one gloved-hand under the power supply to support it. Grasp the power supply handle with your other hand and pull the power supply completely out of the chassis.



CAUTION: Do not bump the output connections. If the connection hits a solid object, it could damage the power supply.

10. Place the JNP10K-PWR-AC3 power supply on an antistatic surface to completely cool before placing the power supply in an antistatic bag for storage.
11. Install the replacement JNP10K-PWR-AC3 power supply.



CAUTION: Use the same type of power supply in all slots. Do not mix power supply models in a production chassis.

Install a JNP10K-PWR-DC Power Supply

Before you install a JNP10K-PWR-DC power supply in the chassis:

- Ensure that you have followed all safety warnings and cautions:



WARNING: Before you perform DC power procedures, ensure there is no power to the DC circuit. To ensure that all power is off, locate the circuit breaker on the panel board that services the DC circuit, switch the circuit breaker to the off position, and tape the switch handle of the circuit breaker in the off position.



CAUTION: Before you connect power to the router, a licensed electrician must attach a cable lug to the grounding and power cables that you supply. A cable with an incorrectly attached lug can damage the router (for example, by causing a short circuit).



CAUTION: Do not mix AC and DC power supplies in the same chassis.



CAUTION: To meet safety and electromagnetic interference (EMI) requirements and to ensure proper operation, you must connect PTX10008 routers to earth ground before you connect them to power. For installations that require a separate grounding

conductor to the chassis, use the protective earthing terminal on the router chassis to connect to earth ground. For instructions on connecting a PTX10008 router to ground using a separate grounding conductor, see "[Connect the PTX10008 Router to Earth Ground](#)" on page 320.

NOTE: The battery returns of the JNP10K-PWR-DC power supply must be connected as an isolated DC return (DC-I).

- Ensure that you understand how to prevent ESD damage. See *Prevention of Electrostatic Discharge Damage*.
- Ensure that you have the following parts and tools available to install a JNP10K-PWR-DC power supply:
 - Electrostatic discharge (ESD) grounding strap
 - DC power source cables (not provided) with the cable lugs (provided) attached.

The provided Panduit LCD4-14A-L, or equivalent, terminal lugs in a PTX10008 are sized for either 4 AWG (21.1 mm²) or 6 AWG (13.3 mm²) power source cables. When using all JNP10K-PWR-DC power supply modules in the chassis, the DC power source cables that you provide must be 6 AWG (13.3 mm²) stranded wire. We recommend that you install heat-shrink tubing insulation around the crimped section of the power cables and lugs.

NOTE: If you upgrade the JNP10K-PWR-DC to a JNP10K-PWR-DC2 and set the input mode to high (80 A), you must use 4 AWG (21.1 mm²) stranded wire. The 4 AWG (21.1 mm²) stranded wire should be rated 75° C, or per local electrical code.

NOTE: See the heat symbol



. Wear heat-resistant gloves while accessing the fan tray and power supply.

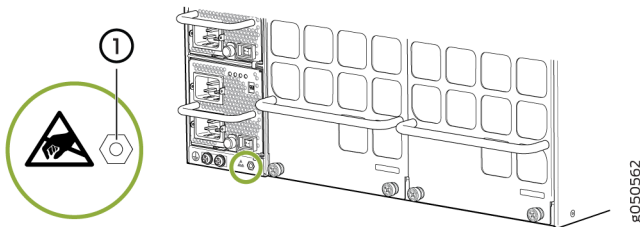
- 13/32 in. (10 mm) nut driver or socket wrench
- Phillips (+) screwdrivers, numbers 1 and 2

- Multimeter
- Heat resistant gloves

To install a JNP10K-PWR-DC power supply in a PTX10008 router:

1. Wrap and fasten one end of the ESD grounding strap around your bare wrist and connect the other end of the strap to an ESD point on the chassis. There is an ESD point located next to the protective earthing terminal and below **PSU 5** on the rear of the PTX10008 (see [Figure 165 on page 393](#)).

Figure 165: ESD Point on the Rear of the PTX10008



1– ESD point

2. Taking care not to touch power supply components, pins, leads, or solder connections, remove the power supply from its bag.



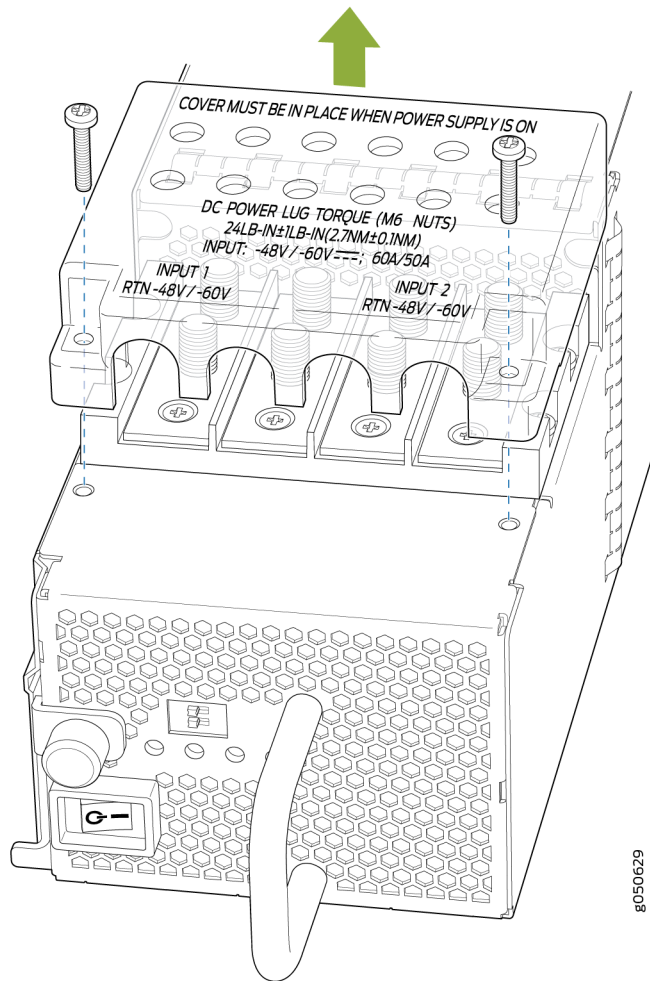
CAUTION: See the heat symbol



. The power supply surfaces are hot. Allow a few minutes for the power supply to cool by pulling the power supply halfway out of the chassis, or wear heat-resistant gloves while removing the power supply.

3. Peel back and remove the protective plastic wrap that covers all four sides of the power supply.
4. Ensure that the power switch is set to the standby (O) position. This switch turns off the output voltage; it does not interrupt DC.
5. Remove the plastic cable cover from the DC power input terminals by using the Phillips (+) screwdriver, number 2, to loosen the screws (see [Figure 166 on page 394](#)).

Figure 166: Remove the Plastic Cable Cover on a JNP10K-PWR-DC Power Supply



6. Remove the nuts from each DC power input terminal, using the 13/32 in. (10 mm) nut driver or socket wrench to loosen the nuts.

NOTE: The JNP10K-PWR-DC2 power supply requires a dedicated circuit breaker for each input DC feed. You must use a circuit breaker that is rated for 80 A DC with medium delay.

7. Ensure that the power source circuit breaker is open so that the voltage across the cable leads of the DC power source cable is 0 V and that the cable leads do not become active while you are connecting DC power.
8. Install a power lug on each DC power cable. Ensure that the lug meets the double-hole standard lug terminal for 4 AWG wire. The lugs should be dual, 1/4 in. spaced 5/8 in. apart. The terminal must accommodate double-hole standard lug terminal for 4 AWG or larger wire.
9. Verify that the DC power cables are correctly labeled before making connections to the power supply. In a typical power distribution scheme where the return is connected to chassis ground at

the battery plant, you can use a multimeter to verify the resistance of the **-48V** and **RTN** DC cables to chassis ground:

- The cable with very high resistance (indicating an open circuit) to chassis ground is negative (-) and will be installed on the **-48V** (input) DC power input terminal.
- The cable with very low resistance (indicating a closed circuit) to chassis ground is positive (+) and will be installed on the **RTN** (return) DC power input terminal.



CAUTION: You must ensure that power connections maintain the proper polarity. The power source cables might be labeled **(+)** and **(-)** to indicate their polarity. There is no standard color coding for DC power cables.

10. Install heat-shrink tubing insulation around the power cables.

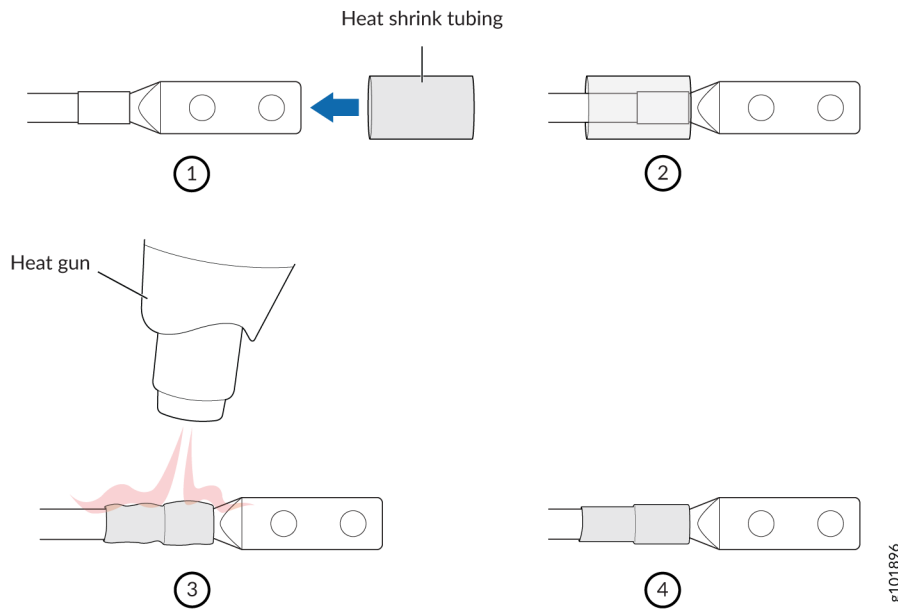
To install heat-shrink tubing:

- a. Slide the tubing over the portion of the cable where it is attached to the lug barrel. Ensure that tubing covers the end of the wire and the barrel of the lug attached to it.
- b. Shrink the tubing with a heat gun. Ensure that you heat all sides of the tubing evenly so that it shrinks around the cable tightly.

Figure 167 on page 396 shows the steps to install heat-shrink tubing.

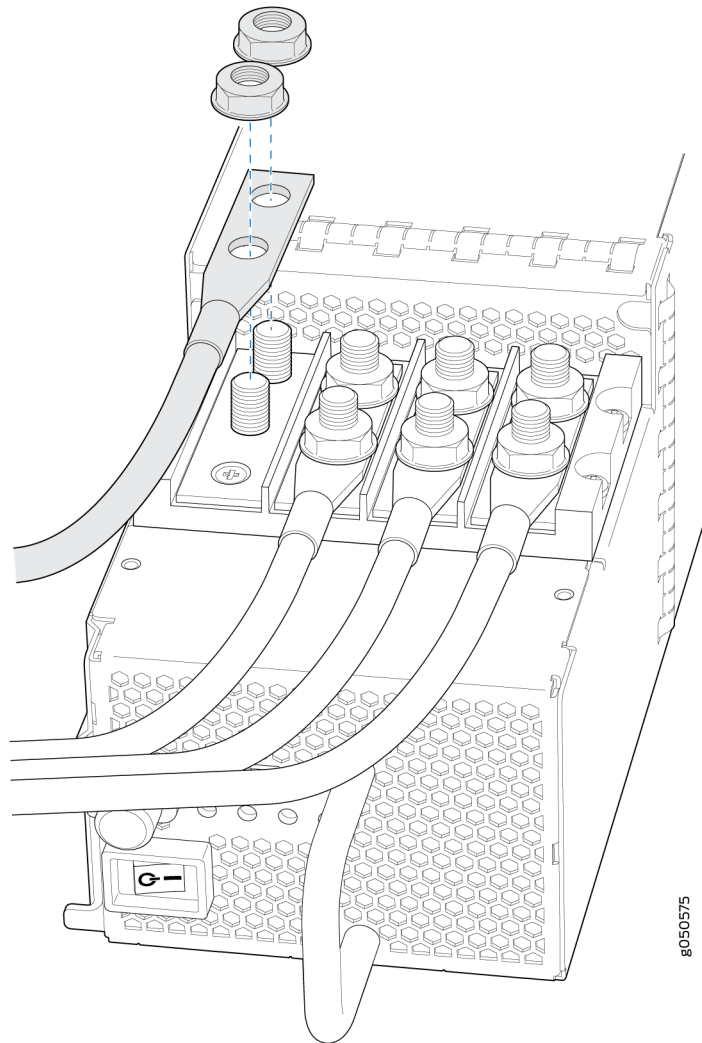
NOTE: Do not overheat the tubing.

Figure 167: How to Install Heat-Shrink Tubing



11. Install each power cable lug on the DC power input terminal, securing it with the nut (see [Figure 168 on page 397](#)). Apply between 23 lb-in. (2.6 Nm) and 25 lb-in. (2.8 Nm) of torque to each nut. (Use the 13/32 in. [10 mm] nut driver or socket wrench.)
 - a. Secure each positive (+) DC source power cable lug to the **RTN** (return) DC power input terminal.
 - b. Secure each negative (-) DC source power cable lug to the **-48V** (input) DC power input terminal.

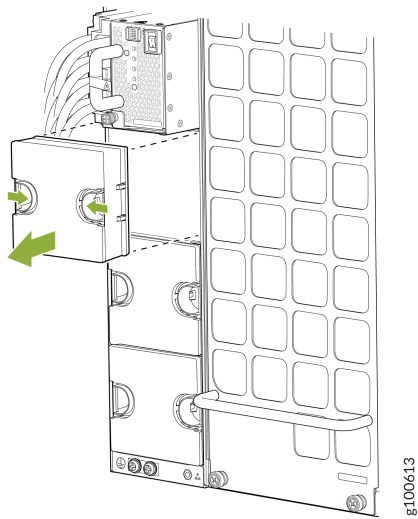
Figure 168: Connect the DC Power Source Cables to a JNP10K-PWR-DC



Each power supply has two independent sets of DC power input terminals (**INPUT 1: RTN -48V/-60V** and **INPUT 2: RTN -48V/760V**). For feed redundancy, each power supply must be powered by dedicated power feeds derived from feed **INPUT 1** and feed **INPUT 2**. This configuration provides the commonly deployed INPUT 1 / INPUT 2 feed redundancy for the router. There is basic insulation between the inputs and the chassis ground. Also, there is basic insulation between RTN input feeds.

12. Install the plastic cable cover over each set of power cables by using the Phillips (+) screwdriver, number 2, to tighten the screw.
13. If the power supply slot on the chassis has a cover on it, insert your thumb and forefinger into the finger holes, squeeze, and pull the cover out of the slot. Save the cover for later use (see [Figure 169 on page 398](#)).

Figure 169: Remove the Power Supply Cover on a PTX10008

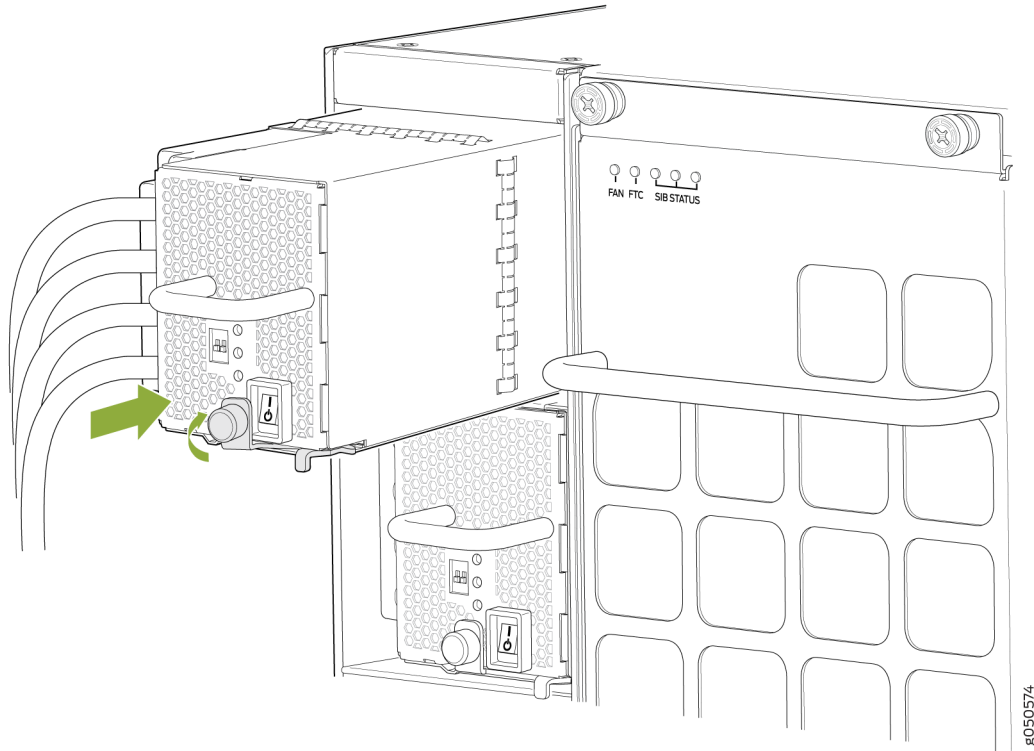


14. Unscrew the captive screw in the counterclockwise direction by using your fingers or by using the Phillips (+) screwdriver, number 1.
15. Pull the captive screw away from the faceplate of the power supply to release the latch.

NOTE: You can install the power supplies in any slot labeled **PSU 0** through **PSU 5** (top to bottom) on a PTX10008.

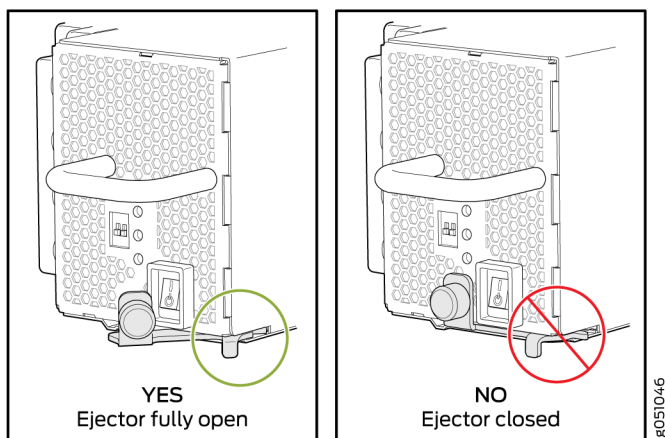
16. Using both hands, place the power supply in the power supply slot on the rear of the router.
17. Slide the power supply straight into the chassis until the power supply is fully seated in the slot. Ensure that the power supply faceplate is flush with any adjacent power supply faceplates or power supply covers (see [Figure 170 on page 399](#)).
18. Push the captive screw into the power supply faceplate. Ensure that the screw is seated inside the corresponding hole on the faceplate.
19. Tighten the captive screw by turning it clockwise by using your fingers or by using the Phillips (+) screwdriver, number 1. Do not overtighten—do not apply more than 7.3 lb-in (0.82 Nm) of torque to the screws. When the screw is completely tight, the latch locks into the router chassis.

Figure 170: Install a JNP10K-PWR-DC Power Supply in a PTX10008



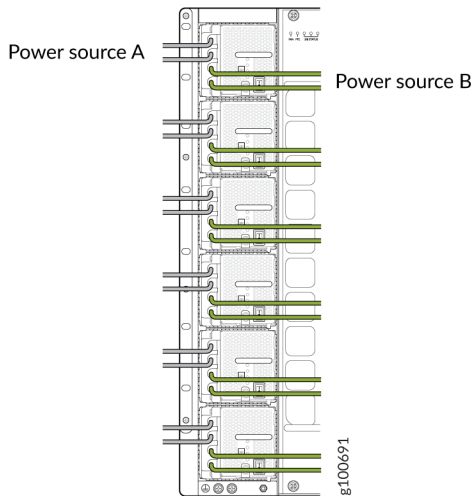
NOTE: Ensure that the ejector is fully open to avoid scratching the chassis (see [Figure 171](#) on page 399).

Figure 171: Proper NP10K-PWR-DC Power Supply Ejector Position



20. Route input 1 cables to a power source and input 2 cables to another power source. The JNP10K-PWR-DC shares power, so if power dips on one input, the power supply is able to load-balance internally. See [Figure 172 on page 400](#).

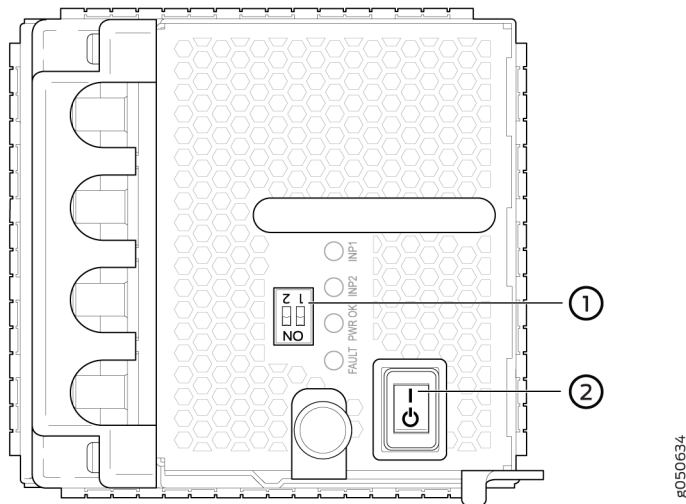
Figure 172: Proper Load Balancing for JNP10K-PWR-DC Power Cables on a PTX10008



WARNING: Ensure that the power cords do not block access to router components or drape where people can trip on them.

21. Set the enable switches for input 1 and input 2 (see [Figure 173 on page 401](#)).
Set both enable switches to the | (on) position when using both source inputs. When not using source redundancy, set the unused source to the off (O) position. The LED turns red and indicates an error if a source input is not in use and the enable switch is on (|).

Figure 173: Set the Enable Switches for the Power Source



1– DIP switches for enabling input sources

2– Power switch, on (I) and standby (O)

22. Verify that the input 1 and 2 LEDs on the power supply faceplate are lit and are on steadily.
23. Press the power switch to the on (I) position.

Remove a JNP10K-PWR-DC Power Supply

Before you remove a JNP10K-PWR-DC power supply from the router:

- Ensure that you understand how to prevent ESD damage. See *Prevention of Electrostatic Discharge Damage*.
- Ensure that you have the following parts and tools available to remove a JNP10K-PWR-DC power supply:
 - Electrostatic discharge (ESD) grounding strap
 - Phillips (+) screwdriver, numbers 1 and 2
 - 13/32 in. (10 mm) nut driver or socket wrench
 - Replacement power supply or a cover for the power supply slot
 - Heat-protective gloves



CAUTION: Before you remove a power supply, ensure that you have power supplies sufficient to power the router left in the chassis. See ["PTX10008 Power Planning for JNP10008-SF3 Switch Fabric" on page 244](#) or ["PTX10008 Power Planning for JNP10008-SF Switch Fabric" on page 207](#).



WARNING: Before performing DC power procedures, ensure that power is removed from the DC circuit. To ensure that all power is off, locate the circuit breaker on the panel board that services the DC circuit, switch the circuit breaker to the off (O) position, and tape the switch handle of the circuit breaker in the off position.

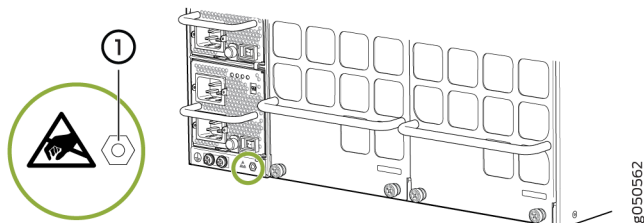


CAUTION: Do not leave the power supply slot empty for a long time while the router is operational. Either replace the power supply promptly or install a cover over the empty slot.

To remove a JNP10K-PWR-DC power supply from a PTX10008 router (see [Figure 175 on page 403](#)):

1. Wrap and fasten one end of the ESD grounding strap around your bare wrist and connect the other end of the strap to an ESD point on the chassis. There is an ESD point located next to the protective earthing terminal and below **PSU 5** on the rear of the PTX10008 (see [Figure 174 on page 402](#)).

Figure 174: ESD Point on the Rear of the PTX10008

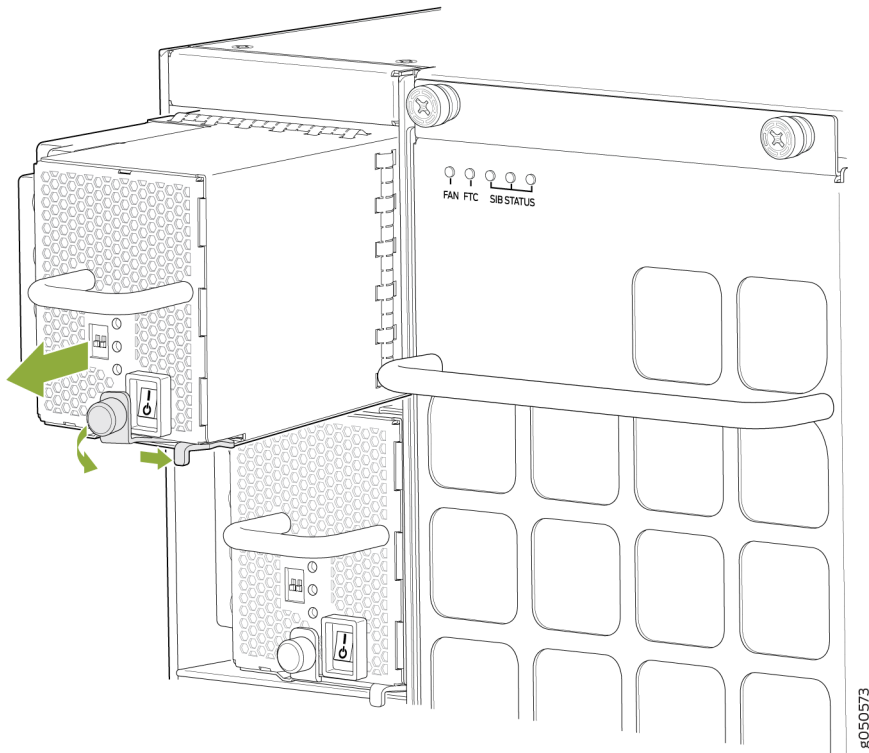


1– ESD point

2. Make sure that the voltage across the DC power source cables leads is 0 V and that there is no chance that the cables might become active during the removal process.
3. Ensure that the power switch is set to the standby position (O).
4. Unscrew the captive screw counterclockwise by using your fingers or by using the Phillips (+) screwdriver, number 1.

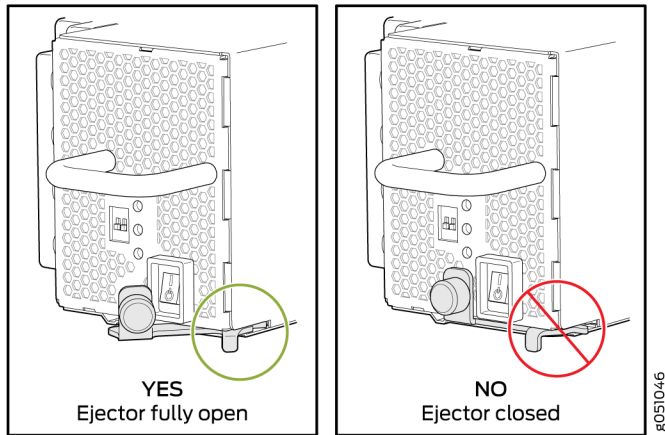
5. Rotate the captive screw away from the faceplate of the power supply to release the latch. See [Figure 175 on page 403](#).

Figure 175: Remove a JNP10K-PWR-DC Power Supply from a PTX10008



NOTE: Ensure that the ejector is fully open to avoid scratching the chassis.

Figure 176: Power Supply Ejector



6. Taking care not to touch power supply components, pins, leads, or solder connections, place one gloved hand under the power supply to support it. Grasp the power supply handle with your other hand and pull the power supply completely out of the chassis.



CAUTION: See the heat symbol



. The power supply surfaces are hot. Allow a few minutes for the power supply to cool by pulling the power supply halfway out of the chassis, or wear heat-resistant gloves while removing the power supply.

7. If you are not replacing the power supply, install the cover over the slot. To install the cover, insert your thumb and forefinger into the finger holes of the cover, squeeze to retract the spring latches, and place the cover in the slot. Do not run the chassis without a power supply or cover in place.
8. Unscrew the screw on the plastic cable cover that shields the input terminal studs counterclockwise by using the number 2 Phillips (+) screwdriver.
9. Unscrew the nuts counterclockwise, using the 13/32 in. (10 mm) nut driver or socket wrench from the input terminal studs.
10. Remove the cable lugs from the input terminal studs.

Install a JNP10K-PWR-DC2 Power Supply

Before you install a JNP10K-PWR-DC2 power supply in the chassis:

- Ensure that you have followed all safety warnings and cautions:



WARNING: Before performing DC power procedures, ensure that power is removed from the DC circuit. To ensure that all power is off, locate the circuit breaker on the panel board that services the DC circuit, switch the circuit breaker to the off (O) position, and tape the switch handle of the circuit breaker in the off position.



WARNING: Protect yourself from severe burns by wearing heat-protective gloves when removing a working JNP10K-PWR-DC2 power supply from the chassis. JNP10K-PWR-DC2 power supplies can reach temperatures between 158° F and 176° F (70° C to 80° C) under running conditions.



CAUTION: Before you connect power to the router, a licensed electrician must attach a cable lug to the grounding and power cables that you supply. A cable with an incorrectly attached lug can damage the router (for example, by causing a short circuit).



CAUTION: Use the same type of power supply in all slots. Do not mix power supply models in a production chassis.



CAUTION: To meet safety and electromagnetic interference (EMI) requirements and to ensure proper operation, you must connect PTX10008 routers to earth ground before you connect them to power. For installations that require a separate grounding conductor to the chassis, use the protective earthing terminal on the router chassis to connect to earth ground. For instructions on connecting a PTX10008 router to ground using a separate grounding conductor, see "[Connect the PTX10008 Router to Earth Ground](#)" on page 320.

NOTE: The battery returns of the JNP10K-PWR-DC2 power supply must be connected as an isolated DC return (DC-I).

- Ensure that you understand how to prevent ESD damage. See *Prevention of Electrostatic Discharge Damage*.
- Ensure that you have the following parts and tools available to install a DC power supply:
 - Electrostatic discharge (ESD) grounding strap
 - Use high current cable assembly, CBL-PWR2-BARE (not provided) with the cable lugs (provided) attached.

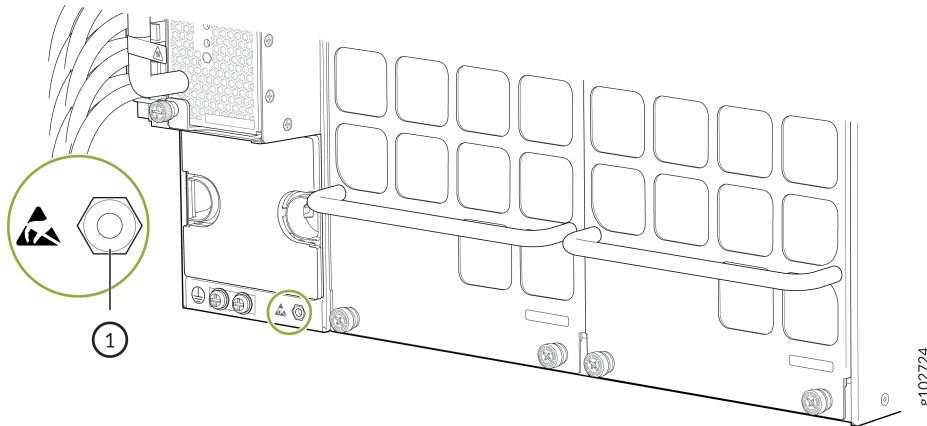
The provided terminal lugs for the JNP10K-PWR-DC2 are Panduit LCD4-14A-L, or equivalent, and sized for 4 AWG (21.1 mm²) power source cables. The 4 AWG (21.1 mm²) stranded wire should be rated 75° C, or per local electrical code. We recommend that you install heat-shrink tubing insulation around the crimped section of the power cables and lugs.

- 13/32 in. (10 mm) nut driver or socket wrench
- Phillips (+) screwdrivers, numbers 1 and 2
- Multimeter

To install a JNP10K-PWR-DC2 power supply in a PTX10008 router:

1. Wrap and fasten one end of the ESD grounding strap around your bare wrist and connect the other end of the strap to an ESD point on the chassis. There is an ESD point located next to the protective earthing terminal and below **PSU 5** on the rear of the PTX10008 (see [Figure 177 on page 407](#)).

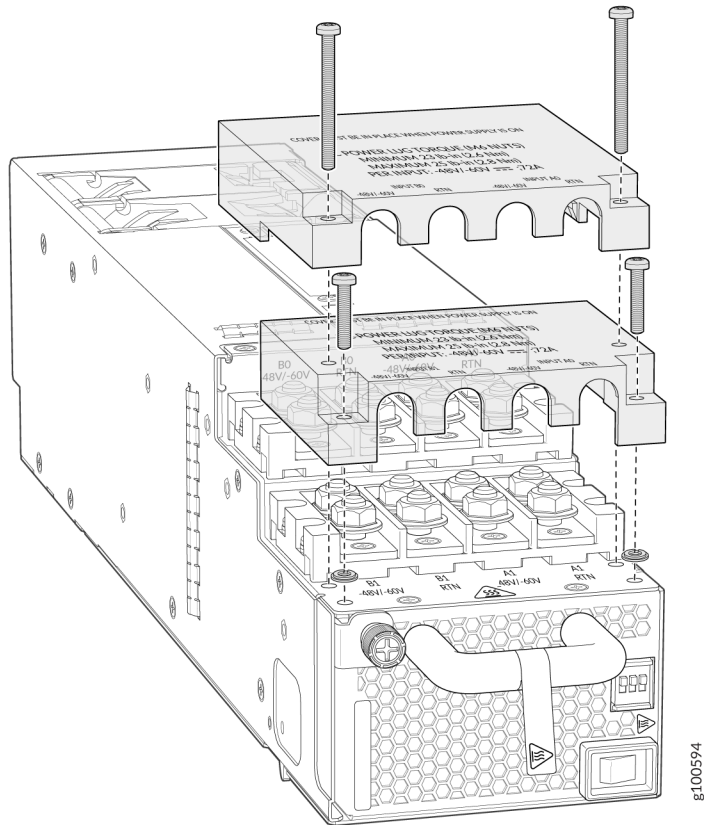
Figure 177: ESD Point on Rear of the PTX10008



1– ESD point

2. Taking care not to touch power supply components, pins, leads, or solder connections, remove the power supply from its bag.
3. Peel back and remove the protective plastic wrap that covers all four sides of the power supply.
4. Ensure that the power switch is set to the standby (O) position. This switch turns off the output voltage; it does not interrupt DC.
5. Remove the plastic cable cover from the power input terminals by using the Phillips (+) screwdriver, number 2, to loosen the screws (see [Figure 178 on page 408](#)).

Figure 178: Remove the Plastic Cable Cover on a JNP10K-PWR-DC2 Power Supply



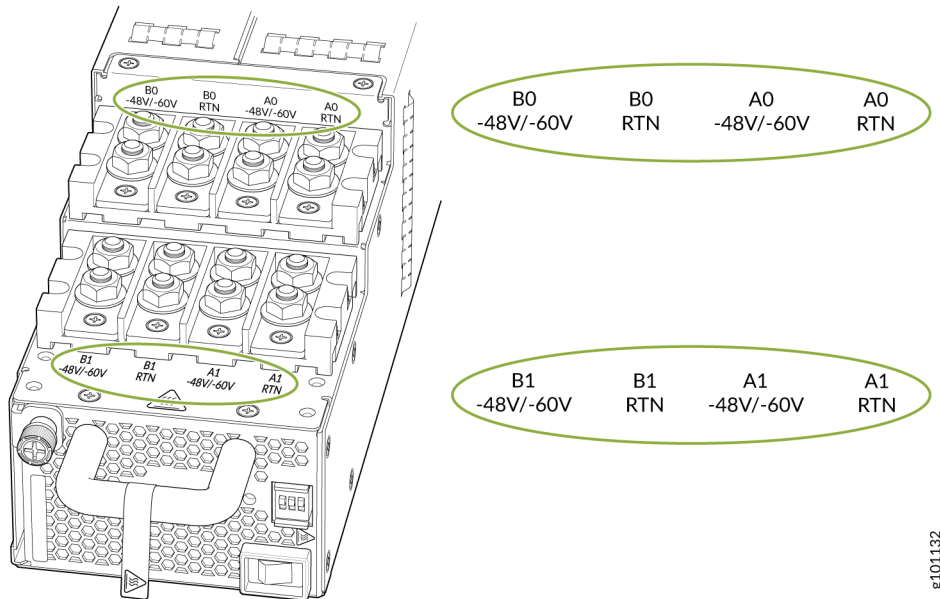
6. Remove the nuts from each DC power input terminal, using the 13/32 in. (10 mm) nut driver or socket wrench to loosen the nuts.
7. Ensure that the power source circuit breaker is open so that the voltage across the DC power source cable leads is 0 V and that the cable leads do not become active while you are connecting DC power.
8. Verify that the DC power cables are correctly labeled before making connections to the power supply. In a typical power distribution scheme where the return is connected to chassis ground at the battery plant, you can use a multimeter to verify the resistance of the **-48V** and **RTN** DC cables to chassis ground:
 - The cable with very high resistance (indicating an open circuit) to chassis ground is negative (-) and will be installed on the **-48V** (input) DC power input terminal.
 - The cable with very low resistance (indicating a closed circuit) to chassis ground is positive (+) and will be installed on the **RTN** (return) DC power input terminal.

The JNP10K-PWR-DC2 power supply is the equivalent of two power supplies in a single housing. Each JNP10K-PWR-DC2 has four independent sets of DC power input terminals:

- **A0: INPUT A0 RTN -48V/-60V**

- B0: INPUT B0 RTN -48V/-60V
- A1: INPUT A1 RTN -48V/-60V
- B1: INPUT B1 RTN -48V/-60V

Figure 179: JNP10K-PWR-DC2 Input Terminal Marking



g101132



CAUTION: You must ensure that power connections maintain the proper polarity. The power source cables might be labeled (+) and (-) to indicate their polarity. There is no standard color coding for DC power cables.

We recommend source redundancy (source A and source B) to all inputs to ensure reliability of the system.

If you have two independent power sources (source A and source B): We recommend that you have four sets of independent power feeds—two from source A and two from source B. You must connect the two feeds from source A to terminals A0 and A1 on the power supply and the two feeds from source B to terminals B0 and B1 on the power supply. This will provide the power supply with source and power distribution redundancy.

If you have only one power source and want power distribution redundancy: We recommend that you have four sets of independent power feeds from that source. You must connect the feeds to

terminals A0, A1, B0, and B1 on the power supply. This will provide the power supply with power distribution redundancy.

If you have only one power source and do not want power distribution redundancy: We recommend that you have four sets of independent power feeds from that source. You must connect one pair of feeds to terminal A0 or B0 on the power supply, and you must connect the other pair of feeds to terminal A1 or B1. In this scenario, the power supply delivers the full output power of 5500 W.

If you connect one power feed to A0 and another power feed to B0 or if you connect one power feed to A1 and another power feed to B1, the power supply delivers only half the output power—2750 W. That is because terminals A0 and B0 are associated with PS0 power supply (2750 W) and terminals A1 and B1 are associated with PS1 power supply (2750 W).

9. Install heat-shrink tubing insulation around the power cables.

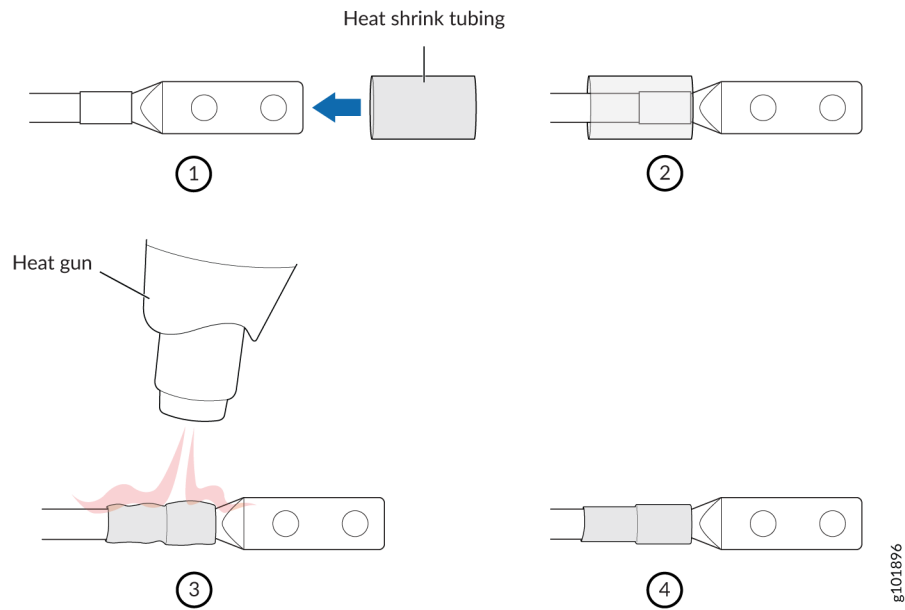
To install heat-shrink tubing:

- a. Slide the tubing over the portion of the cable where it is attached to the lug barrel. Ensure that tubing covers the end of the wire and the barrel of the lug attached to it.
- b. Shrink the tubing with a heat gun. Ensure that you heat all sides of the tubing evenly so that it shrinks around the cable tightly.

Figure 180 on page 411 shows the steps to install heat-shrink tubing.

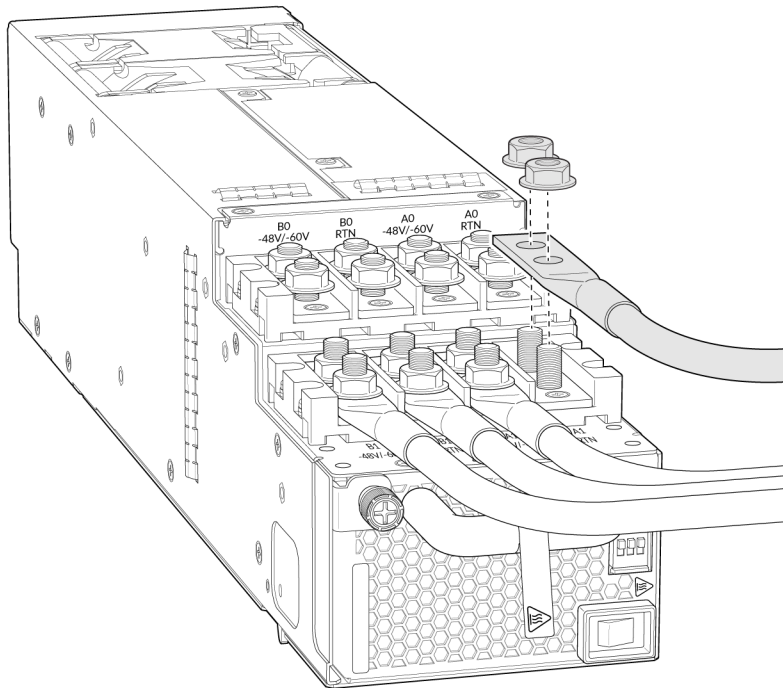
NOTE: Do not overheat the tubing.

Figure 180: How to Install Heat-Shrink Tubing



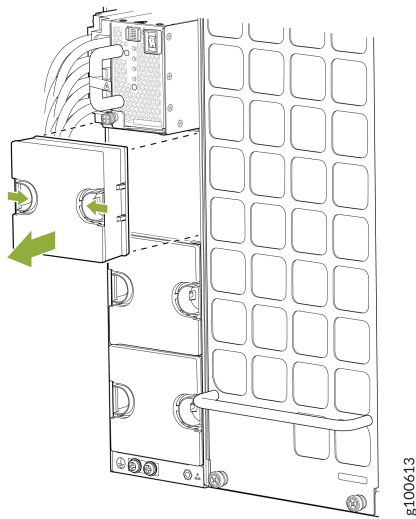
10. Install each power cable lug on the DC power input terminal, securing it with the nut (see [Figure 181 on page 412](#)). Apply between 23 lb-in. (2.6 Nm) and 25 lb-in. (2.8 Nm) of torque to each nut. (Use the 13/32 in. [10 mm] nut driver or socket wrench.)
- Secure each positive (+) DC source power cable lug to the **RTN** (return) DC power input terminal.
 - Secure each negative (-) DC source power cable lug to the **-48V** (input) DC power input terminal.

Figure 181: Connect the DC Power Source Cables to a JNP10K-PWR-DC2 Power Supply



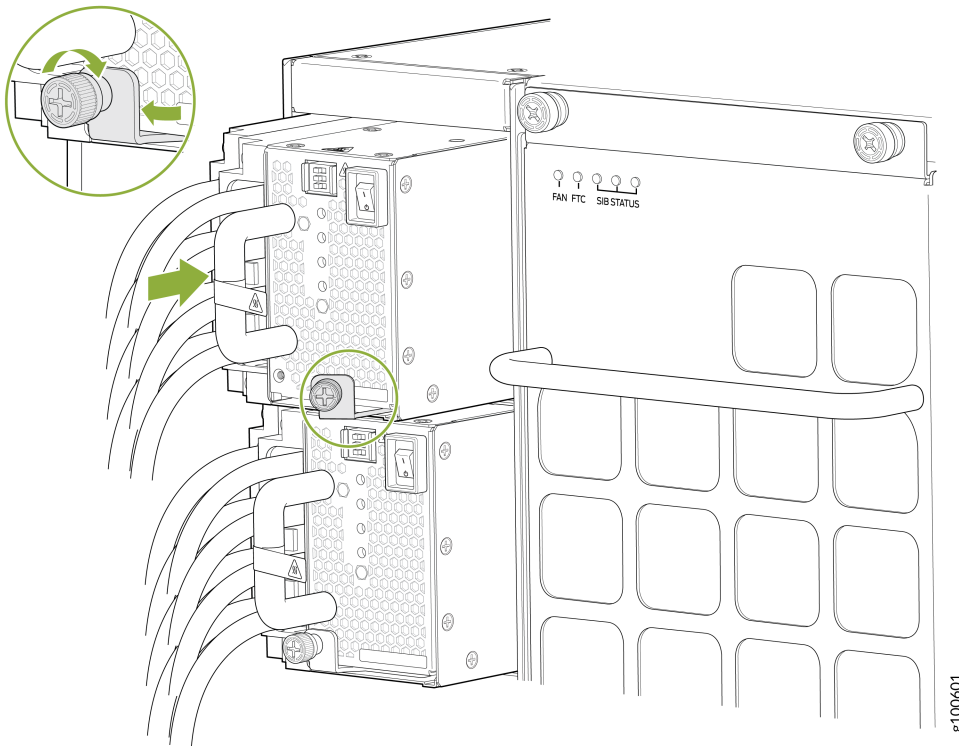
11. Install the plastic cable cover over each set of power cables by using the Phillips (+) screwdriver, number 2, to tighten the screw.
12. If the power supply slot on the chassis has a cover on it, insert your thumb and forefinger into the finger holes, squeeze, and pull the cover out of the slot. Save the cover for later use (see [Figure 182 on page 413](#)).

Figure 182: Remove the Power Supply Cover from a PTX10008



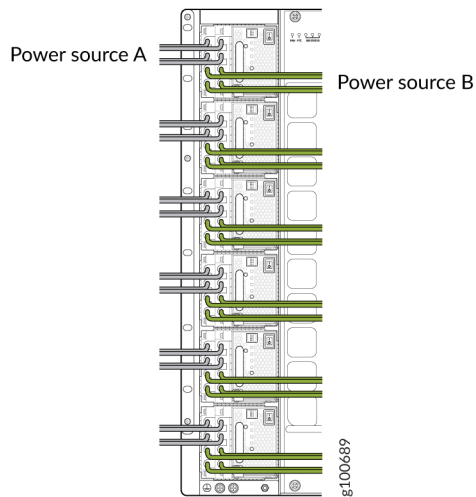
13. Unscrew the captive screw in the counterclockwise direction by using your fingers or by using the Phillips (+) screwdriver, number 1.
14. Rotate the captive screw away from the faceplate of the power supply to release the latch.
15. Using both hands, place the power supply in the power supply slot on the rear of the router. Slide the power supply straight into the chassis until the power supply is fully seated in the slot. The power supply will protrude from the chassis about 2 in. (5 cm) (see [Figure 183 on page 414](#)).
16. Push the captive screw into the power supply faceplate. Ensure that the screw is seated inside the corresponding hole on the faceplate.
17. Tighten the captive screw by turning it clockwise by using your fingers or by using the Phillips (+) screwdriver, number 1. Do not overtighten—do not apply more than 7.3 lb-in (0.82 Nm) of torque to the screws. When the screw is completely tight, the latch locks into the router chassis.

Figure 183: Install a JNP10K-PWR-DC2 in PTX10008



18. Route input A0 and A1 cables to a power source and input B0 and B1 cables to another power source. You must connect each input to a dedicated power distribution and protection. The JNP10K-PWR-DC2 shares power, so if power dips on one input, the power supply is able to load-balance internally. See [Figure 184 on page 415](#).

Figure 184: Proper Load Balancing for JNP10k-PWR-DC2 Power Cables on PTX10008



WARNING: Ensure that the power cords do not block access to router components or drape where people can trip on them.

19. Set the three DIP switches to indicate the number of input sources and to indicate high or low power. See [Table 124 on page 415](#) and [Figure 185 on page 416](#).

Set both enable switches to the **on** position when using both source inputs. When not using source redundancy, set the unused source to the off position. The LED turns red and indicates an error if a source input is not in use and the enable switch is **on**.

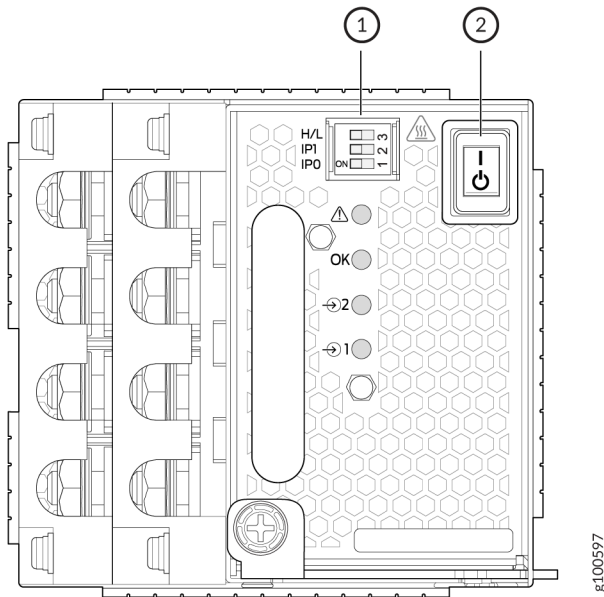
Table 124: Set the JNP10K-PWR-DC2 DIP Switches

Switch	State	Description
1	On	IP0 is present.
	Off	IP0 is not present.
2	On	IP1 is present.
	Off	IP1 is not present

Table 124: Set the JNP10K-PWR-DC2 DIP Switches (Continued)

Switch	State	Description
3	On	Enabled for 80-A feed; 2750 W for a single feed, 5500 W for dual feeds.
	Off	Enabled for 60-A feed; 2200 W for a single feed, 4400 W for dual feeds.

Figure 185: Set the Enable Switches for the Power Source



1– DIP switches

2– Power switch, on (I) and standby (O)

20. Verify that the input 1 and 2 LEDs on the power supply faceplate are lit and are on steadily.
21. Press the power switch to the on (I) position.

Remove a JNP10K-PWR-DC2 Power Supply

Before you remove a DC power supply from the router:

- Ensure that you understand how to prevent ESD damage. See *Prevention of Electrostatic Discharge Damage*.
- Ensure that you have the following parts and tools available to remove a JNP10K-PWR-DC2 power supply:
 - Heat-protective gloves able to withstand temperatures between 158°F to 176°F (70°C to 80°C)
 - Electrostatic discharge (ESD) grounding strap
 - Phillips (+) screwdriver, numbers 1 and 2
 - 13/32 in. (10 mm) nut driver or socket wrench
 - Replacement power supply or a cover for the power supply slot



CAUTION: A working JNP10K-PWR-DC2 power supply can reach temperatures of up to 158°F and 176°F (70°C and 80°C) under running conditions. In order to avoid injury, do not touch a running power supply with your bare hands.



CAUTION: Before you remove a power supply, ensure that you have power supplies sufficient to power the router left in the chassis. See "[PTX10008 Power Planning for JNP10008-SF Switch Fabric](#)" on page 207 and "[PTX10008 Power Planning for JNP10008-SF3 Switch Fabric](#)" on page 244.

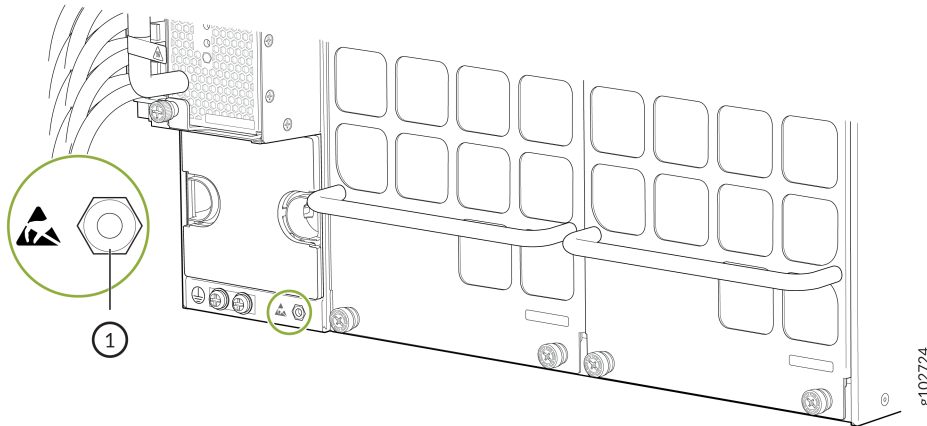


CAUTION: Do not leave the power supply slot empty for a long time while the router is operational. Either replace the power supply promptly or install a cover over the empty slot.

To remove a JNP10K-PWR-DC2 power supply from a PTX10008 router:

1. Wrap and fasten one end of the ESD grounding strap around your bare wrist and connect the other end of the strap to an ESD point on the chassis. There is an ESD point located next to the protective earthing terminal and below **PSU 5** on the rear of the PTX10008 (see [Figure 186 on page 418](#)).

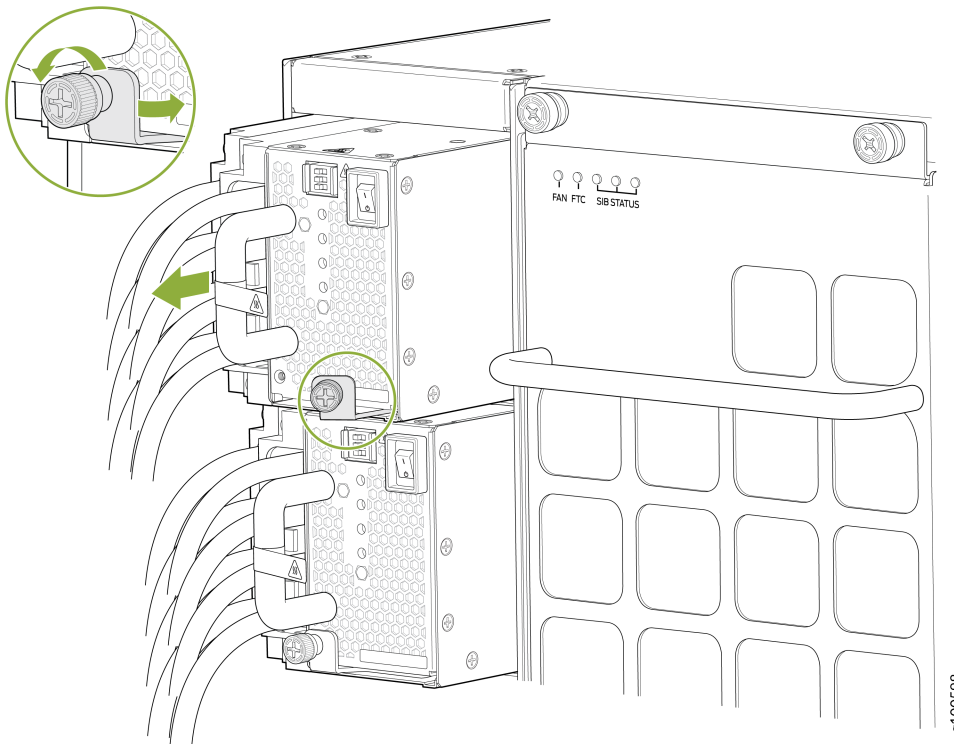
Figure 186: ESD Point on the Rear of the PTX10008



1– ESD point

2. Make sure that the voltage across the DC power source cables leads is 0 V and that there is no chance that the cables might become active during the removal process.
3. Ensure that the power switch is set to the standby (O) position.
4. Unscrew the captive screw counterclockwise by using your fingers or by using the Phillips (+) screwdriver, number 1.
5. Rotate the captive screw away from the faceplate of the power supply to release the latch. (See [Figure 187 on page 419.](#))

Figure 187: Remove a JNP10K-PWR-DC2 Power Supply from PTX10008



6. Wear the heat-resistant gloves to protect your hands from the hot power supply.
7. Taking care not to touch power supply components, pins, leads, or solder connections, place one gloved hand under the power supply to support it. Grasp the power supply handle with your other hand and pull the power supply completely out of the chassis.
8. If you are not replacing the power supply, install the cover over the slot. To install the cover, insert your thumb and forefinger into the finger holes of the cover, squeeze to retract the spring latches, and place the cover in the slot. Do not run the chassis without a power supply or cover in place.
9. Unscrew the screw on the plastic cable cover that shields the input terminal studs counterclockwise by using the Phillips (+) screwdriver, number 2.
10. Unscrew the nuts counterclockwise, using the 13/32 in. (10 mm) nut driver or socket wrench, from the input terminal studs.
11. Remove the cable lugs from the input terminal studs.

RELATED DOCUMENTATION

[JNP10K-PWR-AC Power Supply | 76](#)

[JNP10K-PWR-DC Power Supply | 86](#)

[Connect AC Power to a PTX10008 | 322](#)

[Connect DC Power to a PTX10008 | 323](#)

[PTX10008 Field-Replaceable Units | 49](#)

Install and Remove PTX10008 Switch Fabric Components

IN THIS SECTION

- [How to Handle and Store PTX10008 Line Cards, RCBs, and SIBs | 420](#)
- [Install a PTX10008 Switch Interface Board | 424](#)
- [Remove a PTX10008 Switch Interface Board | 429](#)

Each PTX10008 router contains five or six Switch Interface Boards (SIBs) that are installed vertically, mid-chassis, between the line cards and the Routing and Control Boards (RCBs) in the front and the fan trays in the rear. To install or remove the switch interface boards in a PTX10008 router, read the following sections.

How to Handle and Store PTX10008 Line Cards, RCBs, and SIBs

IN THIS SECTION

- [How to Hold Line Cards and RCBs | 421](#)
- [How to Hold SIBs | 422](#)
- [How to Store Line Cards, RCBs, and SIBs | 424](#)

The PTX10008 chassis have several field-replaceable units (FRUs) that have fragile components. To avoid damaging the line cards, Routing and Control Boards (RCBs), and Switch Interface Boards (SIBs), be sure you follow the following safe handling practices.

How to Hold Line Cards and RCBs

Pay proper attention to the way you are holding line cards and RCBs. Line cards and RCBs are installed horizontally and it is best to hold them by the sides of the units when they are not in the chassis.

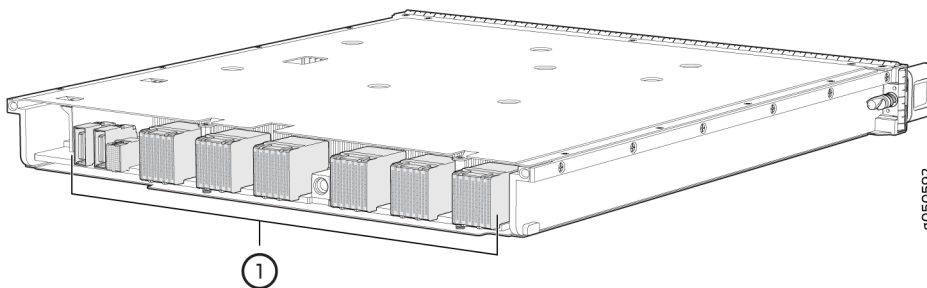
When walking with a line card or RCB:

1. Orient the line card or the RCB so that the faceplate is toward you.
2. Grasp each side of the unit firmly as you slide the unit out of the chassis.
3. Take care not to strike the unit against any object as you carry it.



CAUTION: Never hold the line card or RCB by the connector edge. The connectors are fragile and the line card or RCB will not seat properly if the connector is damaged. See Figure 1.

Figure 188: Connector Edge of a Line Card



1- Connectors

4. If you must rest a line card or an RCB on an edge, place a cushion between the edge and the surface.



CAUTION: Do not stack line cards or RCBs on top of one another or on top of any other component.

5. Place each line card separately in an electrostatic bag or on an antistatic mat placed on a flat, stable surface.

How to Hold SIBs

SIBs are installed vertically and should be held vertically until they are clear of the router before rotating them 90 degrees and placing them on an antistatic mat or placing them in an antistatic bag for storage. See [Figure 189 on page 422](#) and [Figure 190 on page 423](#).

Figure 189: JNP10008-SF SIB

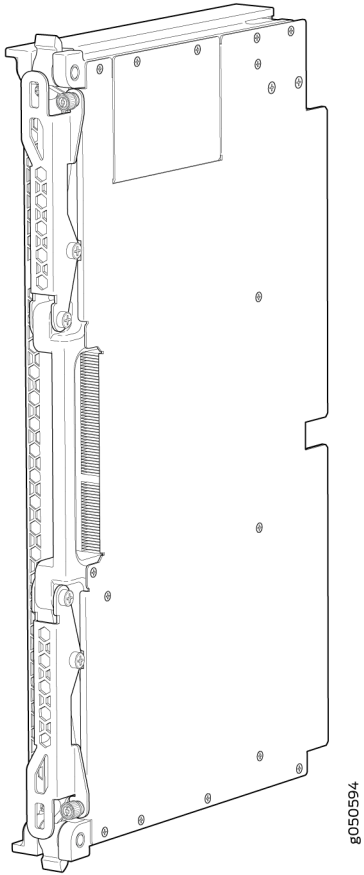
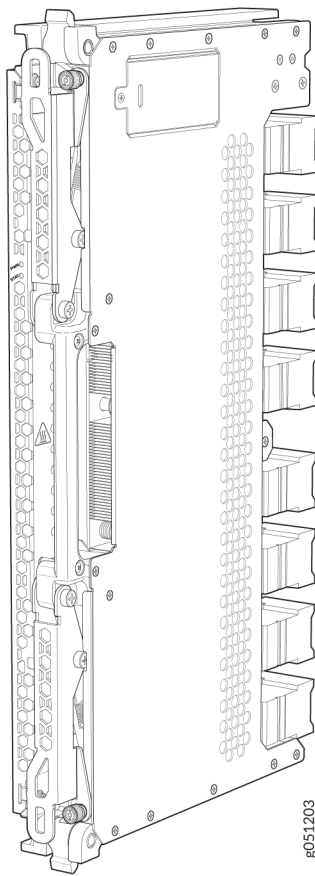


Figure 190: JNP10008-SF3 SIB



The proper method of holding a SIB is to:

1. Hold the SIB by the ejectors while you keep the SIB vertical, and slide the SIB about three-quarters of the way out of the chassis.
2. Place one hand underneath the SIB to support it, and slide it completely out of the chassis.



CAUTION: Never hold the SIB by the connector edge. The connectors are fragile and the SIB will not align and seat properly if the connector is damaged.



CAUTION: Do not stack SIBs on top of one another or on top of any other component.

How to Store Line Cards, RCBs, and SIBs

You must store line cards, RCBs, and SIBs either in the chassis or in a spare shipping container, horizontally and sheet metal side down. Do not stack these units on top of one another or on top of any other component. Place each unit separately in an antistatic bag or on an antistatic mat placed on a flat, stable surface.

NOTE: Because these units are heavy, and because antistatic bags are fragile, inserting the line card into the bag is best done with two people.

To insert a line card, RCB, or SIB into an antistatic bag:

1. Hold the unit horizontally with the faceplate toward you.
2. Slide the opening of the bag over the connector edge.

If you must insert the line card, RCB, or SIB into a bag by yourself:

1. Lay the unit horizontally on an antistatic mat that is on a flat, stable surface with the sheet metal side down.
2. Orient the unit with the faceplate toward you.
3. Carefully insert the connector edge into the opening of the bag and pull the bag toward you to cover the unit.

Install a PTX10008 Switch Interface Board

A PTX10008 router has up to six Switch Interface Boards (SIBs) that are located in the middle of the chassis behind the fan trays. **SIB 0** through **SIB 2** are located behind the left fan tray, and **SIB 3** through **SIB 5** are located behind the right fan tray. You must remove the appropriate fan tray to install a SIB. See ["Remove a PTX10008 Fan Tray" on page 351](#).

Ensure you have the following equipment with you before installing a SIB:

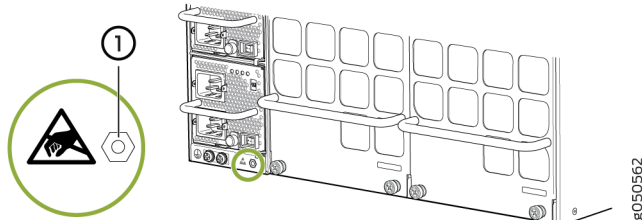
- Antistatic bag or antistatic mat
- Electrostatic discharge (ESD) grounding strap

To install a SIB:

1. Place an antistatic bag or an antistatic mat on a flat, stable surface.
2. Wrap and fasten one end of the ESD grounding strap around your bare wrist and connect the other end of the strap to an ESD point on the chassis. There is an ESD point located next to the

protective earthing terminal and below **PSU 5** on the rear of the PTX10008 (see [Figure 191 on page 425](#)).

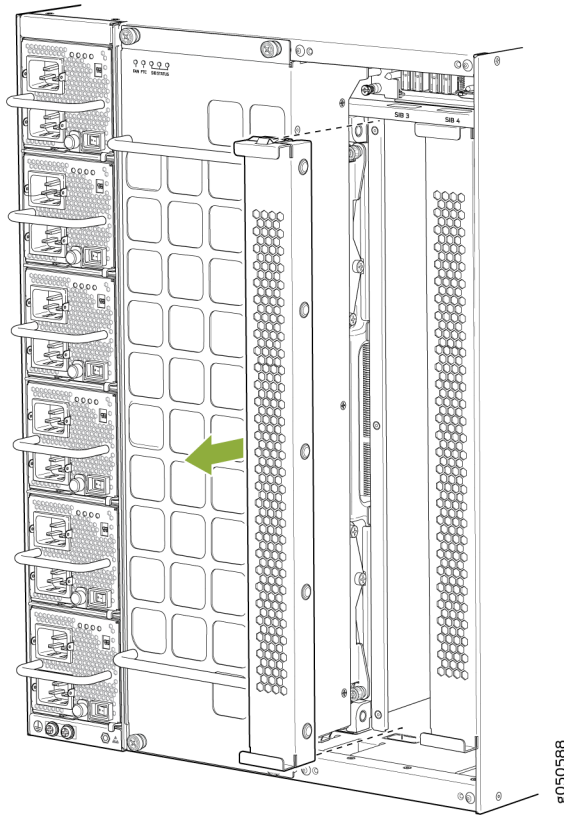
Figure 191: ESD Point on the Rear of the PTX10008



1– ESD point

3. Remove the appropriate fan tray (see ["Remove a PTX10008 Fan Tray" on page 351](#)).
4. Either remove the failing SIB (see ["Remove a PTX10008 Switch Interface Board" on page 429](#)) or remove the cover by grasping each side of the plate and pulling straight out (see [Figure 192 on page 426](#)).

Figure 192: Remove a SIB Cover on a PTX10008

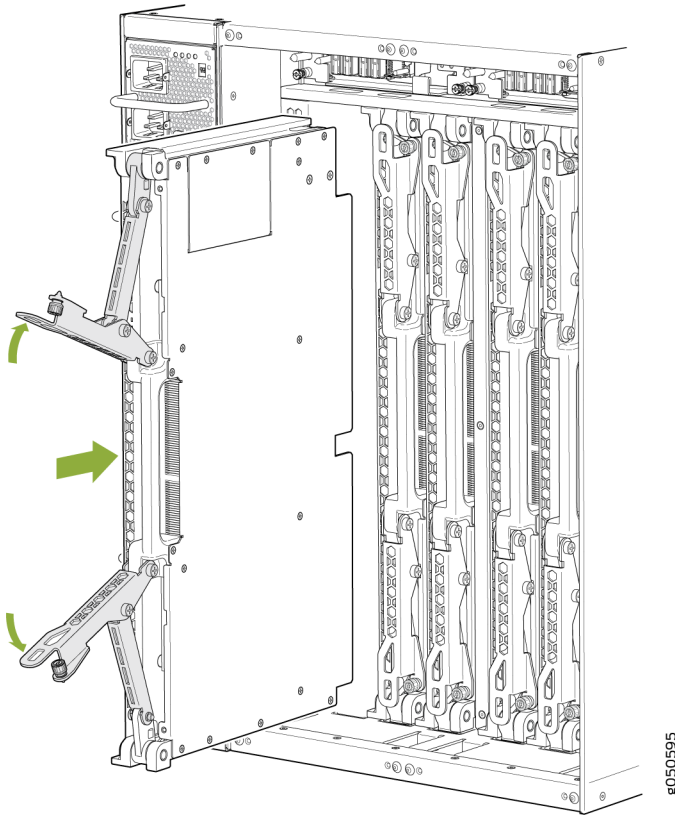


5. Lift the SIB by the handle with one hand and support the lower edge with the other hand.
6. Holding the SIB vertically, slide the SIB into the open slot until the ejector handles engage and start to close.

If you are installing multiple SIBs, such as during a hardware upgrade, install the SIBs from the lowest slot number **0** to the highest **5**. Do not skip slots.

7. Grasp the two ejector handles and fold them inward until they latch to seat the SIB (see [Figure 193](#) on page 427 for the PTX10008).

Figure 193: Install a PTX10008 SIB



8. Hand-tighten the captive screws.
9. Ensure you have SIBs and covers installed in the appropriate slots for your configuration. See [Table 125 on page 427](#).

Table 125: SIB Slot and Cover Assignments

Configuration	SIBs/Slots	Covers/Slots
PTX10008-BASE	5 SIBs in slots 1, 2, 3, 4, and 5	1 cover in slot 0
PTX10008-BASE3	3 SIBs in slots 1, 3, and 5	3 covers in slots 0, 2, and 4
PTX10008-PREMIUM	6 SIBs in slots 0, 1, 2, 3, 4, and 5	0 covers
PTX10008-PREM2	4 SIBs in slots 1, 2, 4 and 5	2 covers in slots 0 and 3

Table 125: SIB Slot and Cover Assignments (Continued)

Configuration	SIBs/Slots	Covers/Slots
PTX10008-PREM3	6 SIBs in slots 0, 1, 2, 3, 4, and 5	0 covers

- 10.** Bring the SIB online using the request chassis sib slot *slot number* online command.

You can check the status of the SIB using the show chassis fabric sibs and the show chassis fabric plane-location commands. For example:

```

root> show chassis fabric sibs
Fabric management SIB state:
SIB #0 Online
  FASIC #0 (plane 0) Active
    FPC #0
      PFE #0 : OK
      PFE #1 : OK
      PFE #2 : OK
      PFE #3 : OK
      PFE #4 : OK
      PFE #5 : OK
    FPC #3
      PFE #0 : OK
      PFE #1 : OK
      PFE #2 : OK
      PFE #3 : OK
      PFE #4 : OK
      PFE #5 : OK
  FASIC #1 (plane 1) Active
    FPC #0
      PFE #0 : OK
      PFE #1 : OK
      PFE #2 : OK
      PFE #3 : OK
      PFE #4 : OK
      PFE #5 : OK
    FPC #3
      PFE #0 : OK
      PFE #1 : OK
      PFE #2 : OK
      PFE #3 : OK

```



```

PFE #4 : OK
PFE #5 : OK
SIB #1 Empty
SIB #2 Empty
SIB #3 Empty
SIB #4 Empty
SIB #5 Empty

root> show chassis fabric plane-location
-----Fabric Plane Locations-----
SIB          Planes
0            0    1
1            2    3
2            4    5
3            6    7
4            8    9
5           10   11

```

NOTE: If you completely powered off the SIB using the `set chassis sib power-off slot slot` command, you must delete the configuration in order to bring the SIB online. To delete the configuration and bring a replacement SIB online, use the `delete chassis sib power-off slot slot number` command.

Remove a PTX10008 Switch Interface Board

A PTX10008 router has up to six Switch Interface Boards (SIBs) that are located in the middle of the chassis behind the fan trays. **SIB 0** through **SIB 2** are located behind the left fan tray and **SIB 3** through **SIB 5** are located behind the right fan tray. You must remove the appropriate fan tray to access the failing SIB. See ["Remove a PTX10008 Fan Tray" on page 351](#).

Ensure you have the following equipment on hand before replacing a SIB:

- Antistatic bag or antistatic mat
- Electrostatic discharge (ESD) grounding strap

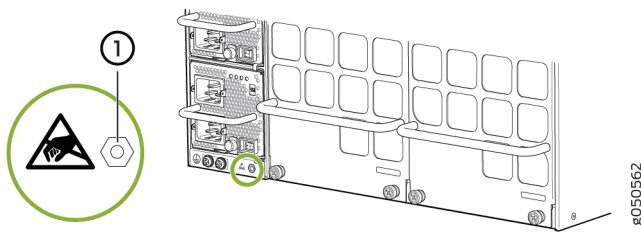
To remove a SIB (see [Figure 196 on page 432](#)):

1. Take the SIB offline using the `request chassis sib slot slot number offline` command.

NOTE: If you suspect the SIB is faulty and want to ensure that packets do not flow through the SIB, power off the SIB instead of taking the SIB offline. To power down the SIB, use the `set chassis sib power-off slot slot number` command. Before you bring a new SIB in that slot online, you must delete the old configuration using the `delete chassis sib power-off slot slot number` command.

2. Place an antistatic bag or an antistatic mat on a flat, stable surface.
3. Wrap and fasten one end of the ESD grounding strap around your bare wrist and connect the other end of the strap to an ESD point on the chassis. There is an ESD point located next to the protective earthing terminal and below **PSU 5** on the rear of the PTX10008 (see [Figure 194 on page 430](#)).

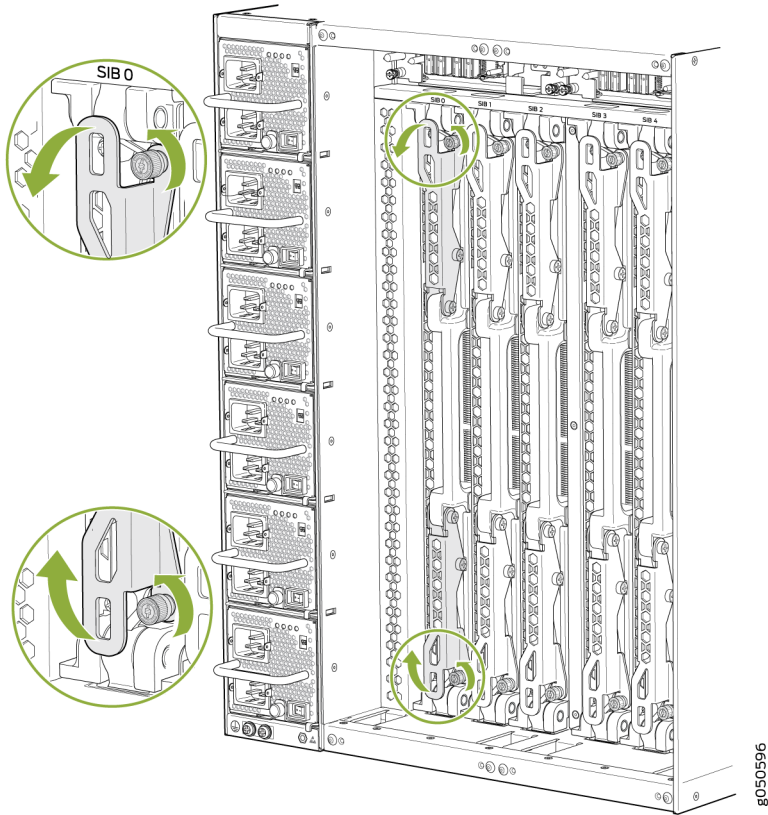
Figure 194: ESD Point on Rear of the PTX10008



1- ESD point

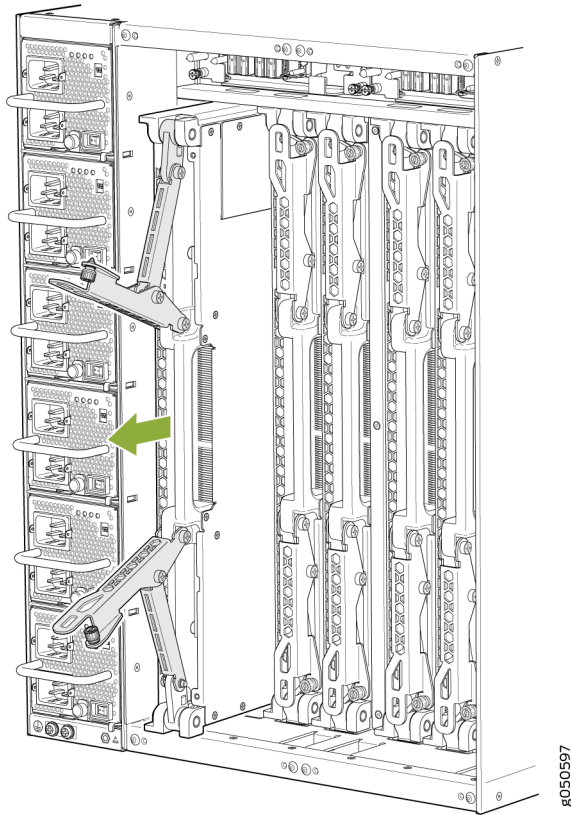
4. Remove the appropriate fan tray (see ["Remove a PTX10008 Fan Tray" on page 351](#)).
5. Using your fingers, loosen the captive screws at the top and bottom of the SIB.
6. Grasp both ejector handles and spread them apart. The SIB slides about a quarter of the way out of the slot. See [Figure 195 on page 431](#).

Figure 195: Loosen the Captive Screws and Spread the Ejector Handles



7. Grasp the ejector handle with one hand and place your other hand under the SIB for support as you slide the SIB out of the slot (see [Figure 196 on page 432](#)).

Figure 196: Removing the SIB from a PTX10008 Chassis

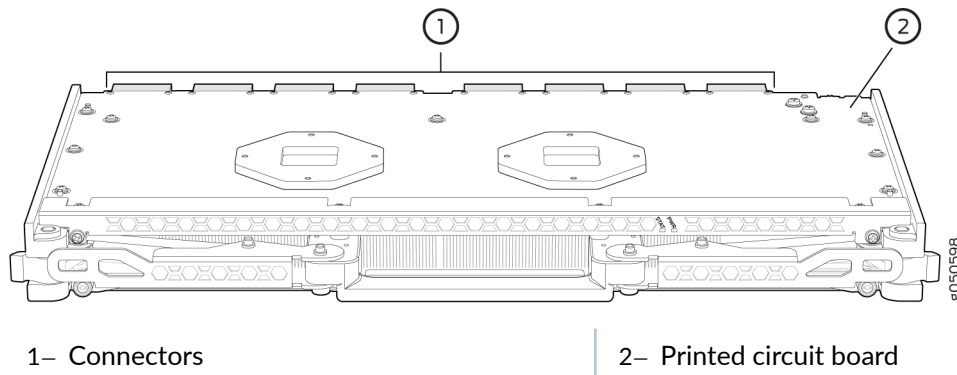


8. Support the SIB as you rotate the SIB 90 degrees and place it on the antistatic mat with the printed circuit board (PCB) facing upward. Be careful not to bump or handle the SIB by the connectors. If you do not have an antistatic mat, have another person help you slide the antistatic bag over the SIB before placing it on a stable surface. See [Figure 197 on page 433](#).



CAUTION: Do not stack hardware components on top of one another after you remove them. Place each component on an antistatic mat resting on a stable, flat surface.

Figure 197: Extracted SIB



RELATED DOCUMENTATION

[PTX10008 Switch Interface Board Description | 115](#)

[PTX10008 Switch Interface Board LEDs | 119](#)

Install and Remove PTX10008 Line Card Components

IN THIS SECTION

- [Install a PTX10008 Line Card | 434](#)
- [Remove a PTX10008 Line Card | 437](#)
- [Install the PTX10008 Cable Management System | 439](#)

Line cards on the PTX10008 are field-replaceable units (FRUs) that can be installed in any of the line card slots on the front of the chassis. The line cards are hot-insertable and hot-removable: you can remove and replace them without powering off the router or disrupting router functions.

The line cards fall into two categories: line cards with the JNP10008-SF connector and line cards with the JNP10008-SF3 connector for 14.4 Tbps support. The two types of line cards are designed to only

work with the matching type of SIB that has the mating connector. You can't mix the two types of line cards in the same chassis. See [Table 126 on page 434](#).

Table 126: Line Cards and Matching SIBs

Line Cards Using SIB JNP10008-SF	Line Cards Using SIB JNP10008-SF3
1. PTX10K-LC1101	PTX10K-LC1201
2. PTX10K-LC1102	PTX10K-LC1202-36MR
3. PTX10K-LC1104	
4. PTX10K-LC1105	
5. QFX10000-60S-6Q	

You can use the `show chassis hardware models` CLI command to determine which type of SIB is installed.

Install a PTX10008 Line Card

Before you install a line card in the router chassis:

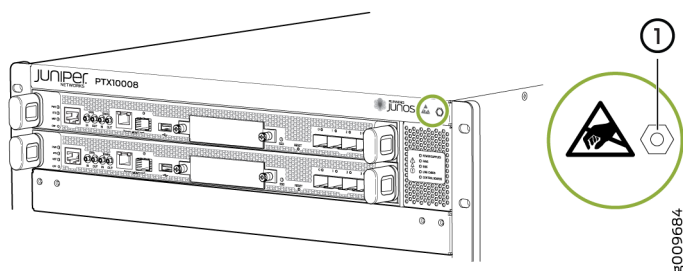
- Ensure you have the right SIBs installed for the new line card. The PTX10K-LC1201 is only compatible with the JNP10008-SF3 SIB; other line cards are compatible with the JNP10008-SF SIB. You cannot mix SIBs in the same chassis. See ["PTX10008 Switch Fabric" on page 115](#).
- Ensure that you have taken the necessary precautions to prevent electrostatic discharge (ESD) damage. See *Prevention of Electrostatic Discharge Damage*.
- Ensure that you know how to handle and store the line card. See ["How to Handle and Store PTX10008 Line Cards, RCBs, and SIBs" on page 420](#).
- Inspect the connector edge of the line card for physical damage. Installing a damaged line card might damage the router.
- Ensure that the router has sufficient power to power the line card while maintaining its $n+1$ power redundancy. To determine whether the router has enough power available for the line card, use the `show chassis power-budget-statistics` command.
- Ensure that you have the following parts and tools available to install a line card in the router:
 - ESD grounding strap

- Phillips (+) screwdriver, number 2

To install a line card in the router chassis:

1. Wrap and fasten one end of the ESD grounding strap around your bare wrist and connect the other end of the strap to one of the ESD points on the chassis. The ESD point is located above the status LED panel on the front of the router chassis. See [Figure 198 on page 435](#).

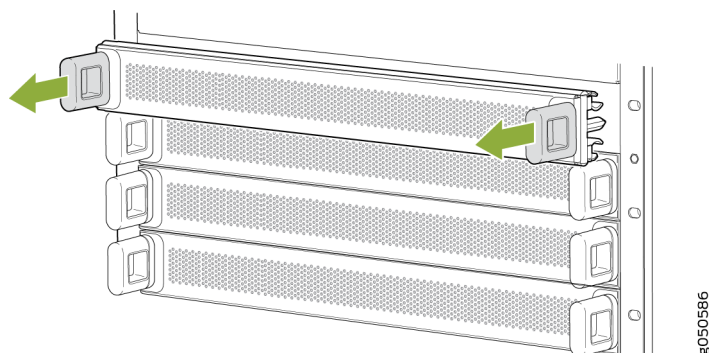
Figure 198: ESD Point on the Front of the PTX10008



1– ESD point

2. Remove the line card cover by grasping the handles and pulling straight out to expose the slot for the line card. See [Figure 199 on page 435](#).

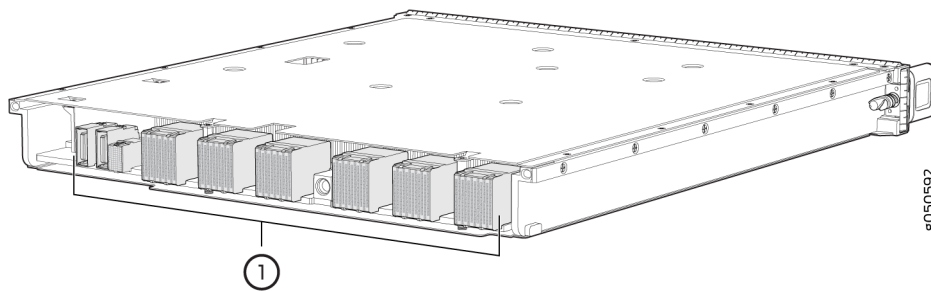
Figure 199: Remove the Cover for a Line Card



CAUTION: Do not lift the line card by holding the edge connectors or the handles on the faceplate. Neither the handles nor the edge connectors can support the weight of the line card. Lifting the line card by the handles or edge connectors might bend them,

which would prevent the line cards from being properly seated in the chassis. See [Figure 200 on page 436](#).

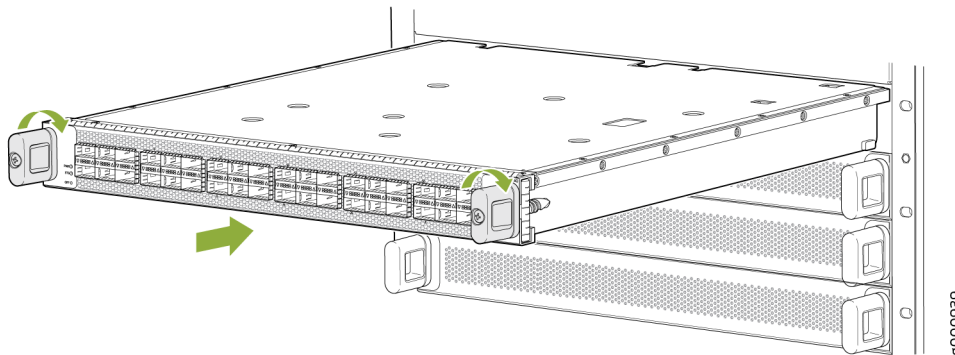
Figure 200: Line Card Connectors



1– Connectors

3. Remove the line card from the antistatic bag and inspect it for any damage before installing it into the chassis.
4. Grasp and lift the line card by the sides.
5. Slide the line card all the way into the slot until the handle holes align. See [Figure 201 on page 436](#).

Figure 201: Insert the Line Card into the Slot and Rotate the Handles



6. Rotate the handles simultaneously into the chassis until the card is fully seated and the handles are vertical.
7. Bring the line card online by using the `request-chassis-fpc slot slot-number online` command. If you are unable to use the command, press the online/offline button labeled OFF by using a non-conductive pin tool, such as a toothpick, for one second, and wait for about 15 seconds until the PWR LED turns on and the STS LED blinks. The online/offline button is recessed below the faceplate

directly below the status (STS) LED. Verify the status information by using the [show chassis fpc](#) command.

You can install the optional cable management kit after the card is installed.

Remove a PTX10008 Line Card

If you have the optional line-card cable management system, it is not necessary to remove the cable management system before removing the line card.

Before you remove a line card from the router chassis:

- Ensure that you have taken the necessary precautions to prevent electrostatic discharge (ESD) damage. See *Prevention of Electrostatic Discharge Damage*.
- If there are any optical cables (including transceivers installed in the line card), remove them before you remove the line card. See ["Remove a Transceiver From a PTX0008" on page 444](#).
- Ensure that you know how to handle and store the line card. See ["How to Handle and Store PTX10008 Line Cards, RCBs, and SIBs" on page 420](#).
- Ensure that you have the following parts and tools available to remove a line card from a PTX10008 chassis:
 - ESD grounding strap
 - An antistatic bag or an antistatic mat

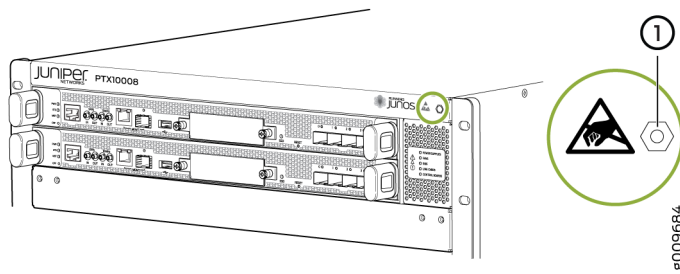
NOTE: Placing a line card in an electrostatic bag might require a second person to assist with sliding the line card into the bag.

- Replacement line card or a cover for the empty slot

To remove a line card from a PTX10008 router chassis:

1. Place the antistatic bag or antistatic mat on a flat, stable surface.
2. Wrap and fasten one end of the ESD grounding strap around your bare wrist and connect the other end of the strap to one of the ESD points on the chassis. An ESD point is located above the status LED panel on the front of the router chassis. See [Figure 202 on page 438](#)).

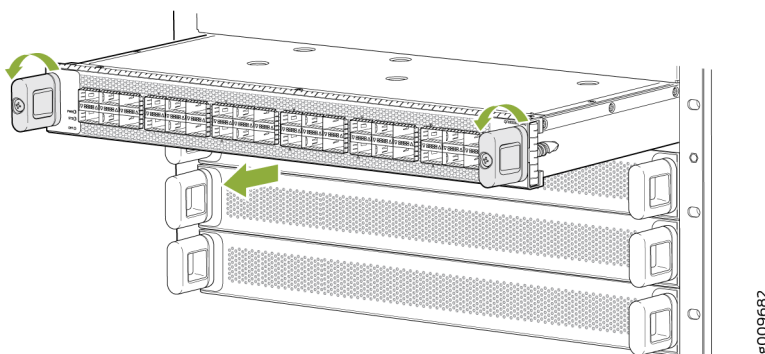
Figure 202: ESD Point on the Front of the PTX10008



1– ESD point

3. Label the cables connected to each port on the line card so you can reconnect the cables to the correct ports.
4. Take the line card offline by using the `request chassis fpc slot slot-number offline` command. If you are unable to use the command, press the online/offline button labeled OFF by using a non-conductive pin tool, such as a toothpick, for one second, and wait for about 5 seconds until the STS LED is off. The online/offline button is recessed below the faceplate directly below the status (STS) LED. Verify the status information by using the `show chassis fpc` command.
5. Unscrew the line card from the chassis by continually turning the handles to the left until the line card is fully unseated. See [Figure 203 on page 438](#).

Figure 203: Remove a PTX10008 Line Card



6. Using the handles, slide the line card halfway out of the chassis.



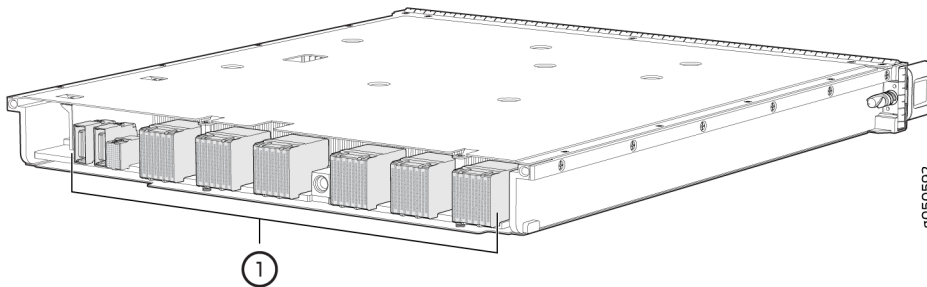
CAUTION: Do not stack line cards on top of one another or on top of any other component. Place each line card separately in the antistatic bag or on the antistatic mat placed on a flat, stable surface.



CAUTION: Each PTX10008 line card weighs between 20.9 lb (9.5 kg) and 27.3 lb (12.4 kg). Be prepared to support the full weight as you slide the line card out of the chassis.

7. Grasp both sides of line card at midpoint and remove the line card from the chassis. Either have someone assist you in putting the line card into the antistatic bag or rest the card on the antistatic mat. Take care not to bump or store the line cards on the connectors. See [Figure 204 on page 439](#).

Figure 204: PTX10008 Line Card Connectors



1– Connectors

8. If you are not installing a line card in the emptied line-card slot within a short time, install a cover over the slot. Do this to protect the interior of the chassis from dust or other foreign substances and to ensure that the airflow inside the chassis is not disrupted.

Install the PTX10008 Cable Management System

The PTX10008 cable management system is an optional, orderable kit (JLC-CBL-MGMT-KIT) that organizes and protects optical cabling attached to the line cards. After a line card is installed, you can still remove the line card without needing to remove the cable management system.

Ensure that you have the following parts and tools available to install the PTX10008 cable management system on a line card:

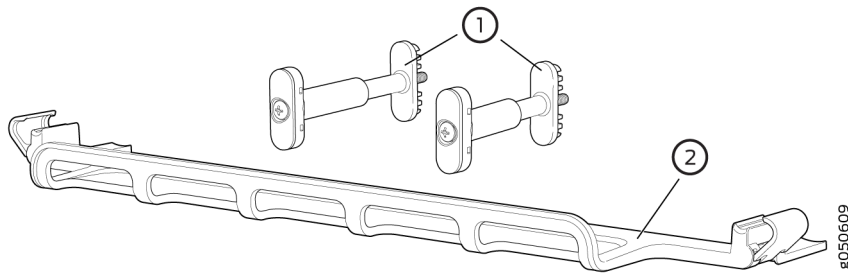
- Phillips (+) screwdriver, number 2

To install the cable management system (see [Figure 205 on page 440](#)):

1. Open the shipping carton for cable management system and check that you have:
 - Two handle extensions

- One cable tray

Figure 205: Cable Management System Components

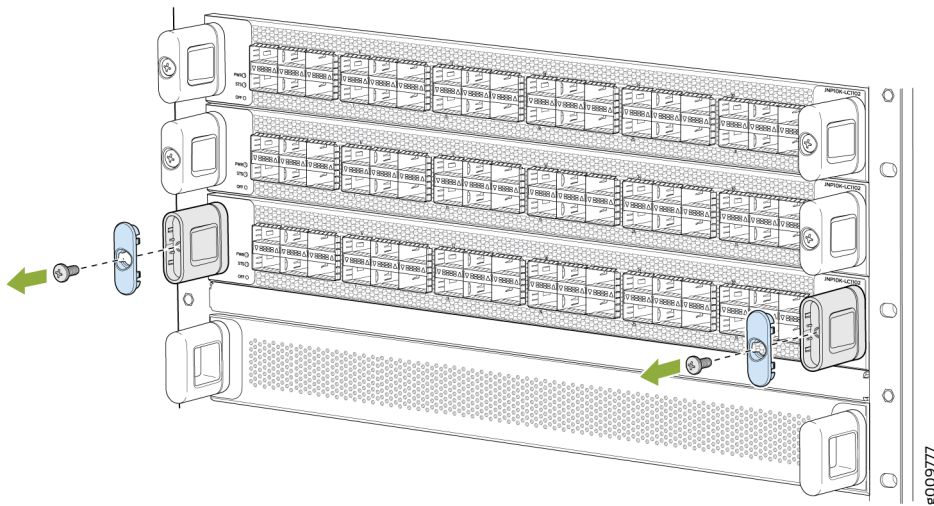


1– Handle extensions

2– Cable tray

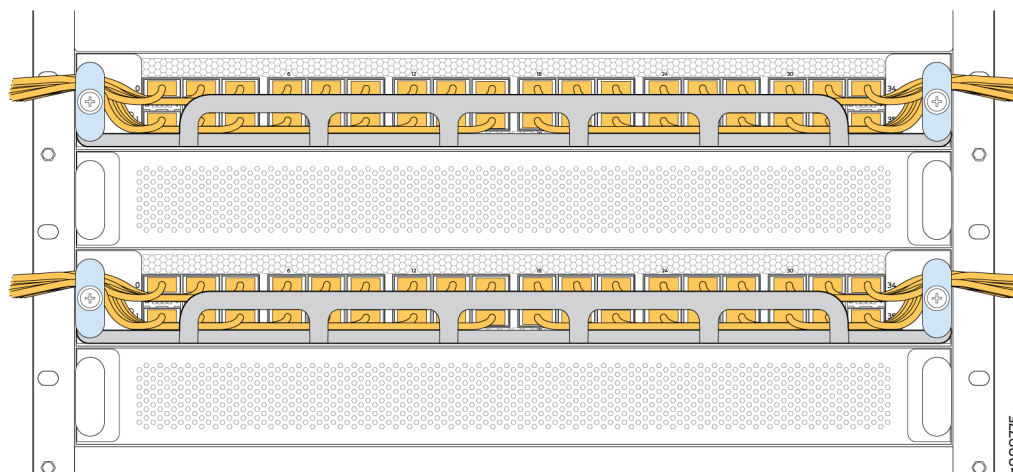
2. Use the Phillips screwdriver to loosen and remove the screws on the two line-card handles (see [Figure 206 on page 440](#)).

Figure 206: Remove the Handle Screws



3. Replace the blue cap on the line-card handle with the two handle extensions (see [Figure 207 on page 441](#)).

Figure 209: Completed Cable Management System



RELATED DOCUMENTATION

[PTX10008 Optional Equipment | 55](#)

[How to Handle and Store PTX10008 Line Cards, RCBs, and SIBs | 420](#)

PTX10008 Transceiver and Fiber Optic Cable Installation and Removal

IN THIS SECTION

- [Install a PTX10008 Transceiver | 443](#)
- [Remove a Transceiver From a PTX0008 | 444](#)
- [Connect a Fiber-Optic Cable from a Transceiver on a PTX10008 Router | 446](#)
- [Disconnect a Fiber-Optic Cable from a Transceiver on a PTX10008 Router | 447](#)
- [Fiber-Optic Cable Maintenance for a PTX10008 Router | 448](#)

The transceivers for the PTX10008 router are hot-removable and hot-insertable field-replaceable units (FRUs). You can remove and replace them without powering off the device or disrupting device functions.

To understand how to install or remove a transceiver of a PTX10008 router read the following sections.

Install a PTX10008 Transceiver

Before you begin installing a transceiver in a PTX10008 line card or RCB, ensure that you have taken the necessary precautions for safe handling of lasers (see *Laser and LED Safety Guidelines and Warnings*).

Ensure that you have a rubber safety cap available to cover the transceiver.

To install a transceiver in the PTX10008 line card or RCB:



CAUTION: To avoid electrostatic discharge (ESD) damage to the transceiver, do not touch the connector pins at the end of the transceiver.

1. Remove the transceiver from its bag.
2. Check to see whether the transceiver is covered by a rubber safety cap. If it is not, cover the transceiver with a rubber safety cap.



LASER WARNING: Do not leave a fiber-optic transceiver uncovered except when inserting or removing a cable. The rubber safety cap keeps the port clean and prevents accidental exposure to laser light.

3. If the port in which you want to install the transceiver is covered with a dust cover, remove the dust cover and save it in case you need to cover the port later.
4. Using both hands, carefully place the transceiver in the empty port. The connectors must face the device chassis.



CAUTION: Before you slide the transceiver into the port, ensure that the transceiver is aligned correctly. Misalignment might cause the pins to bend, making the transceiver unusable. On PTX10008 line cards, the ports are designed belly-to-belly, which requires you to turn the transceiver over on the bottom port row. See [Figure 210 on page 444](#) and [Figure 211 on page 444](#) for the correct orientation for your device.

5. Slide the transceiver in gently until it is fully seated.

- Remove the rubber safety cap when you are ready to connect the cable to the transceiver.



LASER WARNING: Do not look directly into a fiber-optic transceiver or into the ends of fiber-optic cables. Fiber-optic transceivers and fiber-optic cables connected to transceivers emit laser light that can damage your eyes.

Figure 210: Install an SFP Transceiver

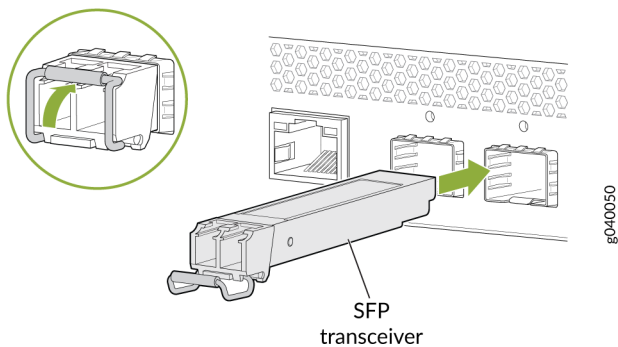
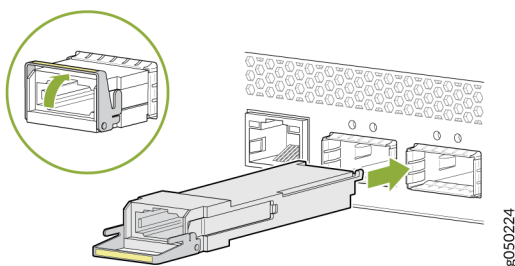


Figure 211: Install a QSFP+, QSFP28, or QSFP56-DD Transceiver



Remove a Transceiver From a PTX0008

Before you begin removing a transceiver from the PTX10008 line card or RCB, ensure that you have taken the necessary precautions for safe handling of lasers (see *Laser and LED Safety Guidelines and Warnings*).

Ensure that you have the following parts and tools available:

- Antistatic bag or an antistatic mat
- Rubber safety caps to cover the transceiver and fiber-optic cable connector
- Dust cover to cover the port

To remove a transceiver from the PTX10008 line card or RCB:

1. Place the antistatic bag or antistatic mat on a flat, stable surface.
2. Wrap and fasten one end of the ESD wrist strap around your bare wrist, and connect the other end of the strap to the ESD point on the switch.
3. Label the cable connected to the transceiver so that you can reconnect it correctly.



LASER WARNING: Do not look directly into a fiber-optic transceiver or into the ends of fiber-optic cables. Fiber-optic transceivers and fiber-optic cables connected to transceivers emit laser light that can damage your eyes.



LASER WARNING: Do not leave a fiber-optic transceiver uncovered except when inserting or removing a cable. The rubber safety cap keeps the port clean and prevents accidental exposure to laser light.



CAUTION: Do not bend fiber-optic cables beyond their minimum bend radius. Bending the cables beyond their minimum bend radius can damage the cables and cause problems that are difficult to diagnose.

4. Remove the cable connected to the transceiver (see ["Disconnect a Fiber-Optic Cable from a Transceiver on a PTX10008 Router" on page 447](#)). Cover the transceiver and the end of each fiber-optic cable connector with a rubber safety cap immediately after disconnecting the fiber-optic cables.
5. Using your fingers, pull the ejector lever away from the transceiver to unlock the transceiver.



CAUTION: Before removing the transceiver, make sure you open the ejector lever completely until you hear it click. This prevents damage to the transceiver.

6. Grasp the transceiver ejector lever and gently slide the transceiver approximately 0.5 in. (1.3 cm) straight out of the port.



CAUTION: To prevent electrostatic discharge (ESD) damage to the transceiver, do not touch the connector pins at the end of the transceiver.

7. Using your fingers, grasp the body of the transceiver and pull it straight out of the port.
8. Place the transceiver in the antistatic bag or on the antistatic mat placed on a flat, stable surface.
9. Place the dust cover over the empty port.

Connect a Fiber-Optic Cable from a Transceiver on a PTX10008 Router

Before you connect a fiber-optic cable to an optical transceiver installed in the PTX10008 router, ensure that you have taken the necessary precautions for safe handling of lasers (see *Laser and LED Safety Guidelines and Warnings*).

To connect a fiber-optic cable to an optical transceiver installed in the PTX10008 router:



LASER WARNING: Do not look directly into a fiber-optic transceiver or into the ends of fiber-optic cables. Fiber-optic transceivers and fiber-optic cables connected to transceivers emit laser light that can damage your eyes.



LASER WARNING: Do not stare into the laser beam or view it directly with optical instruments even if the interface has been disabled.

1. If the fiber-optic cable connector is covered by a rubber safety cap, remove the cap. Save the cap.
2. If the optical transceiver is covered by a rubber safety cap, remove the cap. Save the cap.
3. Insert the cable connector into the optical transceiver.
4. Secure the cables so that they are not supporting their own weight. Place excess cable out of the way in a neatly coiled loop. Placing fasteners on a loop helps cables maintain their shape.



CAUTION: Do not bend fiber-optic cables beyond their minimum bend radius. Bending the cables beyond their minimum bend radius can damage the cables and cause problems that are difficult to diagnose.



CAUTION: Do not let fiber-optic cables hang free from the connector. Do not allow fastened loops of cables to dangle, which stresses the cables at the fastening point.

Disconnect a Fiber-Optic Cable from a Transceiver on a PTX10008 Router

Before you disconnect a fiber-optic cable from an optical transceiver installed in the PTX10008 router, ensure that you have taken the necessary precautions for safe handling of lasers (see *Laser and LED Safety Guidelines and Warnings*).

Ensure that you have the following parts and tools available:

- Rubber safety cap to cover the transceiver
- Rubber safety cap to cover the fiber-optic cable connector

To disconnect a fiber-optic cable from an optical transceiver installed in the PTX10008 Router:

1. (Recommended) Disable the port in which the transceiver is installed by including the disable statement at the [edit interfaces] hierarchy level for the specific interface.



LASER WARNING: Do not look directly into a fiber-optic transceiver or into the ends of fiber-optic cables. Fiber-optic transceivers and fiber-optic cables connected to transceivers emit laser light that can damage your eyes.



LASER WARNING: Do not stare into the laser beam or view it directly with optical instruments even if the interface has been disabled.

2. Carefully unplug the fiber-optic cable connector from the transceiver.
3. Cover the transceiver with a rubber safety cap.



LASER WARNING: Do not leave a fiber-optic transceiver uncovered except when inserting or removing a cable. The rubber safety cap keeps the port clean and prevents accidental exposure to laser light.

4. Cover the fiber-optic cable connector with the rubber safety cap.

Fiber-Optic Cable Maintenance for a PTX10008 Router

To maintain fiber-optic cables in the PTX10008 router:

- When you unplug a fiber-optic cable from a transceiver, place rubber safety caps over the transceiver and on the end of the cable.
- Anchor fiber-optic cable to avoid stress on the connectors. When attaching a fiber-optic cable to a transceiver, be sure to secure the fiber-optic cable so that it is not supporting its own weight as it hangs to the floor. Never let a fiber-optic cable hang free from the connector.
- Do not bend fiber-optic cables beyond their minimum bend radius. Bending the cables beyond their minimum bend radius can damage the cables and cause problems that are difficult to diagnose.
- Frequent plugging and unplugging of fiber-optic cables in and out of optical instruments can damage the instruments, which are expensive to repair. Attach a short fiber extension to the optical equipment. Any wear and tear due to frequent plugging and unplugging is then absorbed by the short fiber extension, which is easier and less expensive to replace than the instruments.
- Keep fiber-optic cable connections clean. Microdeposits of oil and dust in the canal of the transceiver or cable connector can cause loss of light, reduction in signal power, and possibly intermittent problems with the optical connection.

To clean the transceiver canal, use an appropriate fiber-cleaning device such as RIFOCS Fiber Optic Adaptor Cleaning Wands (part number 946). Follow the directions in the cleaning kit you use.

After cleaning the transceiver, make sure that the connector tip of the fiber-optic cable is clean. Use only an approved alcohol-free fiber-optic cable cleaning kit such as the Cletop-S® Fiber Cleaner. Follow the directions in the cleaning kit you use.

RELATED DOCUMENTATION

[PTX10008 Transceiver and Cable Specifications](#) | 268

Remove the PTX10008 Router

IN THIS SECTION

- [Power Off a PTX10008 | 449](#)
- [Remove a PTX10008 from a Four-Post Rack Using a Mechanical Lift | 452](#)
- [Remove a PTX10008 Manually from a Four-Post Rack | 454](#)

To power off and remove a PTX10008 router, read the following sections:

Power Off a PTX10008

Before you power off a PTX10008 router:

- Ensure that you have taken the necessary precautions to prevent electrostatic discharge (ESD) damage. See *Prevention of Electrostatic Discharge Damage*.
- Ensure that you do not need to forward traffic through the router.
- Ensure that you have the following parts and tools available to power off the router:
 - An ESD grounding strap
 - An external management device such as a PC
 - An RJ-45 to DB-9 rollover cable to connect the external management device to the console port on one of the RCBs

To power off a PTX10008 router:

1. Connect to the router using one of the following methods:
 - Connect a management device to the console (**CON**) port on a RCB by following the instructions in "[Connect a PTX10008 Router to a Management Console](#)" on page 326.
 - Connect a management device to one of the two management (**MGMT**) ports on the control board by following the instructions in "[Connect a PTX10008 Router to a Network for Out-of-Band Management](#)" on page 325.

2. Shut down Junos OS from the external management device. On standard Junos OS systems, you can use the `request vmhost halt operational mode CLI` command. On Junos OS Evolved systems use the `request system shutdown power-off operational mode CLI` command. These command shuts down the router gracefully and preserves system state information. A message appears on the console, confirming that the operating system has halted.

You see the following output (or something similar, depending on the hardware being shut down) after entering the command:

```
Shutdown NOW!
System going down IMMEDIATELY

Terminated
Poweroff for hypervisor to respawn
Oct 25 10:35:05 init: event-processing (PID 1114) exited with status=1
Oct 25 10:35:05 init: packet-forwarding-engine (PID 1424) exited with status=8
.
Waiting (max 60 seconds) for system process `vnlru_mem' to stop...done
Waiting (max 60 seconds) for system process `vnlru' to stop...done
Waiting (max 60 seconds) for system process `bufdaemon' to stop...done
Waiting (max 60 seconds) for system process `syncer' to stop...
Syncing disks, vnodes remaining...0 0 0 0 done

syncing disks... All buffers synced.
Uptime: 11h0m30s
Normal shutdown (no dump device defined)
unloading fpga driver
unloading fx-scpld
Powering system off using ACPI
kvm: 28646: cpu0 disabled perfctr wrmsr: 0xc1 data 0xabcd
pci-stub 0000:01:00.2: transaction is not cleared; proceeding with reset anyway
pci-stub 0000:01:00.1: transaction is not cleared; proceeding with reset anyway
hub 1-1:1.0: over-current change on port 1
Stopping crond: [ OK ]
Stopping libvirtd daemon: [ OK ]
Shutting down ntpd: [ OK ]
Shutting down system logger: [ OK ]
Shutting down sntpc: [ OK ]
Stopping sshd: [ OK ]
Stopping vhostd: [ OK ]
Stopping watchdog: [ OK ]
Stopping xinetd: [ OK ]
```

```

Sending all processes the TERM signal... [ OK ]
Sending all processes the KILL signal... [ OK ]
Saving random seed: [ OK ]
Syncing hardware clock to system time [ OK ]
Turning off swap: [ OK ]
Unmounting file systems: [ OK ]
init: Re-executing /sbin/init
Halting system...
System halted.

```



CAUTION: The final output of any version of the `request vmhost halt` command is the “The operating system has halted.” message. Wait at least 60 seconds after first seeing this message before following the instructions in Step 4 and Step 5 to power off the router.

3. Wrap and fasten one end of the ESD grounding strap around your bare wrist and connect the other end of the strap to one of the ESD points on the chassis. One ESD point is located above the status LED panel on the front of the router chassis, and the other ESD point is located in the rear below the power supplies.
4. Disconnect power to the router by performing one of the following tasks:
 - AC power supply—Set the enable router switch to the off (O) position and gently pull out the coupler for the power cord from the faceplate.
 - DC power supply—Switch the circuit breaker on the panel board that services the DC circuit to the off position.
5. Remove the power source cable from the power supply faceplate:
 - AC power supply—Remove the power cord from the power supply faceplate by detaching the power cord retainer and gently pulling out the plug end of the power cord connected to the power supply faceplate.
 - DC power supply—Loosen the thumbscrews securing the DC power connector on the power source cables. Remove the power source cables from the power supply.
6. Remove any remaining cables and optics before removing it from the rack.

SEE ALSO

[Connect AC Power to a PTX10008 | 322](#)

[Connect DC Power to a PTX10008 | 323](#)

Remove a PTX10008 from a Four-Post Rack Using a Mechanical Lift

Before you remove the router using a lift:

- Ensure that the rack is stable and secured to the building.
- Ensure there is enough space to place the removed router in its new location and along the path to the new location. See ["PTX10008 Clearance Requirements for Airflow and Hardware Maintenance" on page 205](#).
- Review *General Safety Guidelines and Warnings*.
- Review the chassis lifting guidelines described in ["PTX10008 Chassis Lifting Guidelines" on page 490](#).
- Ensure that the router is safely powered off (see ["Power Off a PTX10008" on page 449](#)).
- Ensure that you have the following parts and tools with you to remove the router:
 - A mechanical lift rated for 500 lbs (226.8 kg)
 - A Phillips (+) screwdriver, number 2 or number 3, depending on the size of your rack mount screws



CAUTION: When removing more than one router chassis from a rack, remove the routers in order from top to bottom.

The router chassis weighs approximately 145 lb (66 kg) with only the fan tray controllers installed. Because of the router's size and weight, we strongly recommend that you use a mechanical lift to remove the PTX10008. Lifting the chassis and removing it from a rack or cabinet requires at least three people.

Make sure the chassis is empty (contains only the fan tray controllers) before you lift it.

NOTE: For instructions on installing a router without using a mechanical lift, see ["Remove a PTX10008 Manually from a Four-Post Rack" on page 454](#).

To remove the router using a mechanical lift (see [Figure 212 on page 454](#)):

1. Remove all line cards, RCBs, power supplies, fan trays, SIBs, and optics before attempting to move the router chassis.
 - ["Remove a PTX10008 Line Card" on page 437](#)
 - ["Remove a PTX10008 Routing and Control Board" on page 345](#)

- ["Remove a JNP10K-PWR-AC Power Supply" on page 369](#)
- ["Remove a JNP10K-PWR-DC Power Supply" on page 401](#)
- ["Remove a JNP10K-PWR-AC2 Power Supply" on page 377](#)
- ["Remove a JNP10K-PWR-DC2 Power Supply" on page 416](#)
- ["Remove a PTX10008 Fan Tray" on page 351](#)
- ["Remove a PTX10008 Switch Interface Board" on page 429](#)

Ensure that all of the removed components are stored in antistatic bags.

2. Use the appropriate Phillips (+) screwdriver to remove the screws that attach the chassis to the rack.
3. Move the lift to the rack and position it so that its platform is centered about 0.5 in. (1.27 cm) below the bottom of the router chassis and as close to it as possible.
4. Carefully slide the router from the mounting tray or the mounting brackets attached to the rack onto the lift.
5. Move the lift away from the rack and lower the platform on the lift.
6. Use the lift to transport the router to its new location.

After moving the router to its new location, install the components in the chassis or store the components in antistatic bags.

Figure 212: Move the PTX10008 Using a Mechanical Lift



SEE ALSO

Power Off a PTX10008

Remove a PTX10008 Manually from a Four-Post Rack

Before you manually remove the router from a rack:

- Ensure that the rack is stable and secured to the building.

- Ensure there is enough space to place the removed router in its new location and along the path to the new location. See ["PTX10008 Clearance Requirements for Airflow and Hardware Maintenance" on page 205](#).
- Review *General Safety Guidelines and Warnings*.
- Review the chassis lifting guidelines described in ["PTX10008 Chassis Lifting Guidelines" on page 490](#).
- Ensure that the router is safely powered off (see ["Power Off a PTX10008" on page 449](#)).
- Ensure you have a Phillips (+) screwdriver, number 2 or number 3, depending on the size of your rack mount screws.

If you cannot use a mechanical lift to remove the router (the preferred method), you can remove it manually.



CAUTION: The chassis weighs approximately 145 lb (66 kg) with only the fan tray controllers installed. Because of the router's size and weight, we strongly recommend that you use a mechanical lift to remove the PTX10008. Lifting the chassis and mounting it in a rack or cabinet requires at least three people.

Make sure the chassis is empty (contains only the backplane) before you lift it.



CAUTION: When removing more than one router chassis from a rack, remove the routers in order from top to bottom.

To manually remove a PTX10008 from a rack:

1. Remove all line cards, RCBs, power supplies, fan trays, SIBs, and optics before attempting to move the router chassis.
 - ["Remove a PTX10008 Line Card" on page 437](#)
 - ["Remove a PTX10008 Routing and Control Board" on page 345](#)
 - ["Remove a JNP10K-PWR-AC Power Supply" on page 369](#)
 - ["Remove a JNP10K-PWR-DC Power Supply" on page 401](#)
 - ["Remove a JNP10K-PWR-AC2 Power Supply" on page 377](#)
 - ["Remove a JNP10K-PWR-DC2 Power Supply" on page 416](#)
 - ["Remove a PTX10008 Fan Tray" on page 351](#)
 - ["Remove a PTX10008 Switch Interface Board" on page 429](#)

Ensure that all of the removed components are stored in antistatic bags.

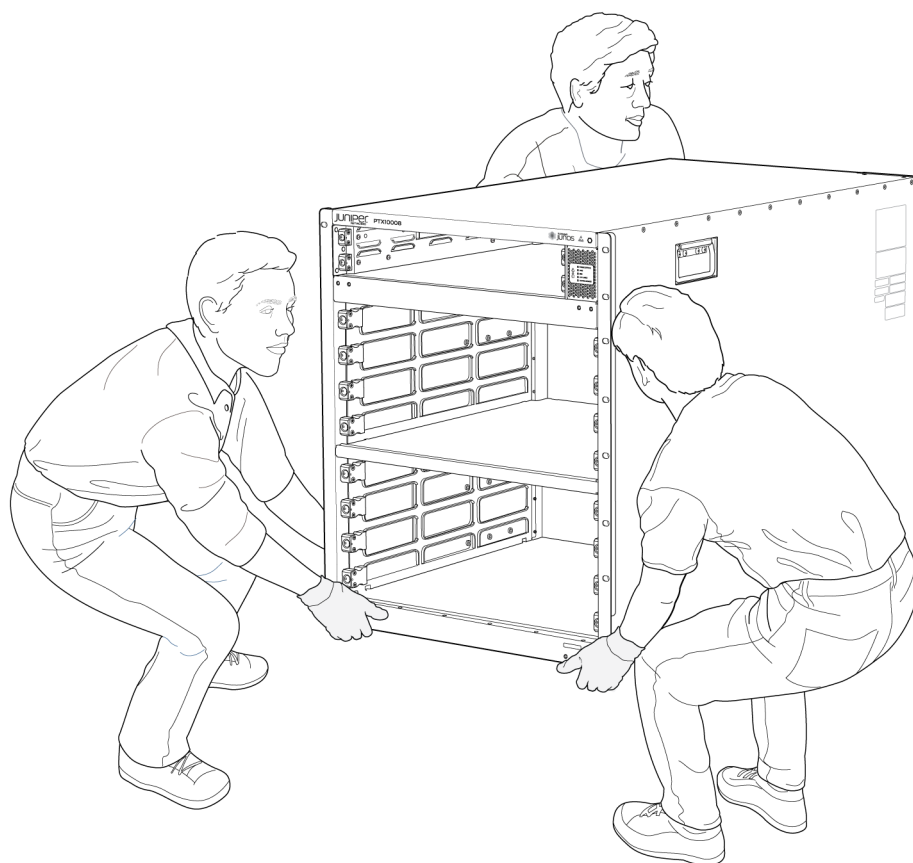
2. Use the appropriate Phillips (+) screwdriver to remove the screws that attach the chassis to the rack.



WARNING: To prevent injury, keep your back straight and lift with your legs, not your back. Do not twist your body as you lift. Balance the load evenly and be sure that your footing is firm.

3. Position one person on each side and another in the rear of the chassis. There are two handles on the side, but these handles are only meant to help guide the empty chassis out of the rack.
4. On each side, hold the bottom of the chassis and carefully lift it up from the mounting tray or mounting brackets.
5. Carefully lift it out of the rack. If you have a pallet jack, move the router onto the pallet jack. See [Figure 213 on page 456](#).

Figure 213: Lift the PTX10008 Without Using a Mechanical Lift



0396008

6. Carefully move the chassis to its new location.

After moving the router to its new location, install the components in the chassis or store the components in antistatic bags.

SEE ALSO

[Remove a PTX10008 from a Four-Post Rack Using a Mechanical Lift | 452](#)

[Connect the PTX10008 Router to Earth Ground | 320](#)

[Connect AC Power to a PTX10008 | 322](#)

[Connect DC Power to a PTX10008 | 323](#)

7

CHAPTER

Troubleshoot Hardware

[Alarm Messages](#) | 459

Alarm Messages

IN THIS SECTION

- [Alarms - A Glossary | 459](#)
- [Interface Alarm Messages | 460](#)

The following sections contain PTX10008 and PTX10016 alarm information.

Alarms - A Glossary

The PTX10008 and PTX10016 routers support different alarm types and severity levels. [Table 127 on page 459](#) provides a list of alarm terms and definitions that may help you in monitoring the device.

Table 127: Alarm Terms and Definitions

Term	Definition
Alarm	Signal alerting you to conditions that might prevent normal operation. On the device, alarm indicators might include the LCD panel and LEDs on the device. The LCD panel (if present on the device) displays the chassis alarm message count. Blinking amber LEDs indicate yellow alarm conditions for chassis components.
Alarm condition	Failure event that triggers an alarm.

Table 127: Alarm Terms and Definitions (Continued)

Term	Definition
Alarm severity levels	<p>Seriousness of the alarm. The level of severity can be either major (red) or minor (yellow).</p> <ul style="list-style-type: none"> • Major (red)—Indicates a critical situation on the device that has resulted from one of the following conditions. A red alarm condition requires immediate action. <ul style="list-style-type: none"> • One or more hardware components have failed. • One or more hardware components have exceeded temperature thresholds. • An alarm condition configured on an interface has triggered a critical warning. • Minor (yellow or amber)—Indicates a noncritical condition on the device that, if left unchecked, might cause an interruption in service or a degradation in performance. A yellow alarm condition requires monitoring or maintenance. For example, a missing rescue configuration generates a yellow system alarm.
Alarm types	<p>Alarms include the following types:</p> <ul style="list-style-type: none"> • Chassis alarm—Predefined alarm triggered by a physical condition on the device such as a power supply failure or excessive component temperature. • Interface alarm—Alarm you configure to alert you when an interface link is down. Applies to ethernet, fibre-channel, and management-ethernet interfaces. You can configure a red (major) or yellow (minor) alarm for the link-down condition, or have the condition ignored. • System alarm—Predefined alarm that might be triggered by a missing rescue configuration, failure to install a license for a licensed software feature, or high disk usage.

Interface Alarm Messages

Interface alarms are alarms that you configure to alert you when an interface is down.

To configure an interface link-down condition to trigger a red or yellow alarm, or to configure the link-down condition to be ignored, use the `alarm` statement at the `[edit chassis]` hierarchy level. You can specify the `ethernet`, `fibre-channel`, or `management-ethernet` interface type.

By default, major alarms are configured for interface link-down conditions on the control plane and management network interfaces. The link-down alarms indicate that connectivity to the control plane

network is down. You can configure these alarms to be ignored using the `alarm` statement at the `[edit chassis]` hierarchy level.

RELATED DOCUMENTATION

show chassis alarms

show system alarms

8

CHAPTER

Contact Customer Support and Return the Chassis or Components

[Contact Customer Support | 463](#)

[Return Procedures for the PTX10008 Chassis or Components | 464](#)

Contact Customer Support

You can contact Juniper Networks Technical Assistance Center (JTAC) 24 hours a day, 7 days a week in one of the following ways:

- On the Web, using the Service Request Manager link at:

<https://support.juniper.net/support/>

- By telephone:
 - From the US and Canada: 1-888-314-JTAC
 - From all other locations: 1-408-745-9500

NOTE: If contacting JTAC by telephone, enter your 12-digit service request number followed by the pound (#) key if this is an existing case, or press the star (*) key to be routed to the next available support engineer.

When requesting support from JTAC by telephone, be prepared to provide the following information:

- Your existing service request number, if you have one
- Details of the failure or problem
- Type of activity being performed on the device when the problem occurred
- Configuration data displayed by one or more `show` commands
- Your name, organization name, telephone number, fax number, and shipping address

The support representative validates your request and issues an RMA number for return of the component.

Return Procedures for the PTX10008 Chassis or Components

IN THIS SECTION

- [Return a PTX10008 Router or Component for Repair or Replacement | 464](#)
- [Locate the Serial Number on a PTX10008 Router or Component | 465](#)
- [Contact Customer Support to Obtain a Return Materials Authorization for a PTX10008 Router or Component | 476](#)
- [How to Pack a PTX10008 or Component for Shipping | 477](#)

To return a PTX10008 router or component, read the following sections:

Return a PTX10008 Router or Component for Repair or Replacement

If you need to return a PTX10008 router, or a component to Juniper Networks for repair or replacement, follow this procedure:

1. Determine the serial number of the component. For instructions, see "[Locate the Serial Number on a PTX10008 Router or Component](#)" on page 465.
2. Obtain a Return Materials Authorization (RMA) number from the Juniper Technical Assistance Center (JTAC), as described in "[Contact Customer Support to Obtain a Return Materials Authorization for a PTX10008 Router or Component](#)" on page 476.

NOTE: Do not return any component to Juniper Networks unless you have first obtained an RMA number. Juniper Networks reserves the right to refuse shipments that do not have an RMA. Refused shipments are returned to the customer through collect freight.

3. Pack the router or component for shipping, as described in "[How to Pack a PTX10008 or Component for Shipping](#)" on page 477.

For more information about return and repair policies, see the customer support page at <https://www.juniper.net/support/guidelines.html>.

SEE ALSO

[PTX10008 Hardware Overview](#) | 15

[How to Pack a PTX10008 or Component for Shipping](#) | 477

Locate the Serial Number on a PTX10008 Router or Component

IN THIS SECTION

- [List the PTX10008 Chassis and Component Details Using the CLI](#) | 466
- [Locate the Chassis Serial Number ID Label on a PTX10008](#) | 469
- [Locate the Serial Number ID Labels on PTX10008 Power Supplies](#) | 470
- [Locate the Serial Number ID Labels on PTX10008 Fan Trays and Fan Tray Controllers](#) | 473
- [Locate the Serial Number ID Labels on PTX10008 Routing and Control Boards](#) | 474
- [Locate the Serial Number ID Labels on a PTX10008 Line Card](#) | 474
- [Locate the Serial Number ID Labels on a PTX10008 Switch Interface Board \(SIB\)](#) | 475
- [Locate the Serial Number ID Label on a PTX10008 SATA SSD](#) | 475

If you are returning a router or component to Juniper Networks for repair or replacement, you must locate the serial number of the router or component. You must provide the serial number to the Juniper Networks Technical Assistance Center (JTAC) when you contact them to obtain a Return Materials Authorization (RMA). See "[Contact Customer Support to Obtain a Return Materials Authorization for a PTX10008 Router or Component](#)" on page 476.

If the router is operational and you can access the command-line interface (CLI), you can list serial numbers for the router and for some components with a CLI command. If you do not have access to the CLI or if the serial number for the component does not appear in the command output, you can locate the serial number ID label on the router or component.

NOTE: If you want to find the serial number ID label on a component, you need to remove the component from the router chassis, for which you must have the required parts and tools available.

List the PTX10008 Chassis and Component Details Using the CLI

To list the PTX10008 chassis and the components and their serial numbers, use the `show chassis hardware` CLI operational mode command. See the following examples for different types of configurations and the related output.

1. This example shows a PTX10008 with a JNP10008-SF fabric running standard Junos OS.

```

user@device> show chassis hardware

Hardware inventory:
Item          Version  Part number  Serial number  Description
Chassis                               DE519          JNP10008 [PTX10008]
Midplane      REV 27   750-071974  ACPD6951      Midplane 8
Routing Engine 1      BUILTIN  BUILTIN      RE-PTX-2X00x4
CB 1          REV 31   750-052688  ACPB6939      Control Board
FPC 0         REV 35   750-071976  ACNS6795      LC1101 - 30C / 30Q / 96X
  CPU                BUILTIN  BUILTIN      FPC CPU
  PIC 0              BUILTIN  BUILTIN      30x100GE/30x40GE/96x10GE
  Xcvr 0            REV 01   740-061405  1ACQ103601D  QSFP-100GBASE-SR4
FPC 1         REV 35   750-071976  ACPD2139      LC1101 - 30C / 30Q / 96X
  CPU                BUILTIN  BUILTIN      FPC CPU
  PIC 0              BUILTIN  BUILTIN      30x100GE/30x40GE/96x10GE
FPC 2         REV 37   750-071976  ACNP1701      LC1101 - 30C / 30Q / 96X
  CPU                BUILTIN  BUILTIN      FPC CPU
  PIC 0              BUILTIN  BUILTIN      30x100GE/30x40GE/96x10GE
  Xcvr 0            REV 01   740-061405  1ACQ12110AU  QSFP-100GBASE-SR4
  Xcvr 1            REV 01   740-061405  1ACQ12110NW  QSFP-100GBASE-SR4
  Xcvr 2            REV 01   740-061405  1ACQ12110NV  QSFP-100GBASE-SR4
  Xcvr 3            REV 01   740-061405  1ACQ12110AE  QSFP-100GBASE-SR4
  Xcvr 4            REV 01   740-061405  1ACQ12110HA  QSFP-100GBASE-SR4
  Xcvr 5            REV 01   740-061405  1ACQ12110NY  QSFP-100GBASE-SR4
  Xcvr 6            REV 01   740-061405  1ACQ12110GX  QSFP-100GBASE-SR4
  Xcvr 7            REV 01   740-061405  1ACQ121107B  QSFP-100GBASE-SR4
  Xcvr 8            REV 01   740-061405  1ACQ12110AD  QSFP-100GBASE-SR4
  Xcvr 9            REV 01   740-061405  1ACQ12110NC  QSFP-100GBASE-SR4
FPC 3         REV 32   750-071976  ACNS7312      LC1101 - 30C / 30Q / 96X
  CPU                BUILTIN  BUILTIN      FPC CPU
  PIC 0              BUILTIN  BUILTIN      30x100GE/30x40GE/96x10GE
FPC 4         REV 35   750-071976  ACPH7094      LC1101 - 30C / 30Q / 96X
  CPU                BUILTIN  BUILTIN      FPC CPU
  PIC 0              BUILTIN  BUILTIN      30x100GE/30x40GE/96x10GE
  Xcvr 0            REV 01   740-054053  QF3208KQ     QSFP+-4X10G-SR

```

Xcvr 1	REV 01	740-054053	QF4605YH	QSFP+-4X10G-SR
Xcvr 2	REV 01	740-054053	QG1500SJ	QSFP+-4X10G-SR
Xcvr 3	REV 01	740-054053	QF4605YM	QSFP+-4X10G-SR
FPC 5	REV 35	750-071976	ACPD3055	LC1101 - 30C / 30Q / 96X
CPU		BUILTIN	BUILTIN	FPC CPU
PIC 0		BUILTIN	BUILTIN	30x100GE/30x40GE/96x10GE
FPC 6	REV 35	750-071976	ACPD1831	LC1101 - 30C / 30Q / 96X
CPU		BUILTIN	BUILTIN	FPC CPU
PIC 0		BUILTIN	BUILTIN	30x100GE/30x40GE/96x10GE
FPC 7	REV 35	750-071976	ACPD2168	LC1101 - 30C / 30Q / 96X
CPU		BUILTIN	BUILTIN	FPC CPU
PIC 0		BUILTIN	BUILTIN	30x100GE/30x40GE/96x10GE
Xcvr 28	REV 01	740-058734	1ECQ113834H	QSFP-100GBASE-SR4
Xcvr 29	REV 01	740-032986	QF4303FE	QSFP+-40G-SR4
FPD Board	REV 07	711-054687	ACPC7192	Front Panel Display
Power Supply 0	REV 01	740-073147	1EDM6130223	Power Supply DC
Power Supply 1	REV 01	740-073147	1EDM6130145	Power Supply DC
Power Supply 2	REV 01	740-073147	1EDM6130205	Power Supply DC
Power Supply 3	REV 01	740-073147	1EDM6130288	Power Supply DC
Power Supply 4	REV 01	740-073147	1EDM6171060	Power Supply DC
Power Supply 5	REV 01	740-073147	1EDM6130352	Power Supply DC
FTC 0	REV 14	750-072657	ACNZ3483	Fan Controller 8
FTC 1	REV 14	750-072657	ACPE3951	Fan Controller 8
Fan Tray 0	REV 09	760-072656	ACNX9388	Fan Tray 8
Fan Tray 1	REV 09	760-072656	ACNV1977	Fan Tray 8
SIB 0	REV 24	750-072655	ACNZ2090	Switch Fabric 8
SIB 1	REV 24	750-072655	ACNZ2155	Switch Fabric 8
SIB 2	REV 24	750-072655	ACNY6520	Switch Fabric 8
SIB 3	REV 24	750-072655	ACNX7482	Switch Fabric 8
SIB 4	REV 24	750-072655	ACNZ2246	Switch Fabric 8
SIB 5	REV 24	750-072655	ACNZ2234	Switch Fabric 8

2. This example shows a PTX10008 with a JNP10008-SF3 fabric running Junos OS Evolved.

```

user@device> show chassis hardware
Hardware inventory:
Item          Version  Part number  Serial number  Description
Chassis                               JN001          JNP10008 [PTX10008]
Midplane 0    REV 06    750-054097  ACAM4922      Midplane 8
PSM 0         Rev 02    740-069994  1F219110277  JNP10K 5500W AC/HVDC Power Supply
Unit
PSM 1         Rev 03    740-069994  1F269200064  JNP10K 5500W AC/HVDC Power Supply

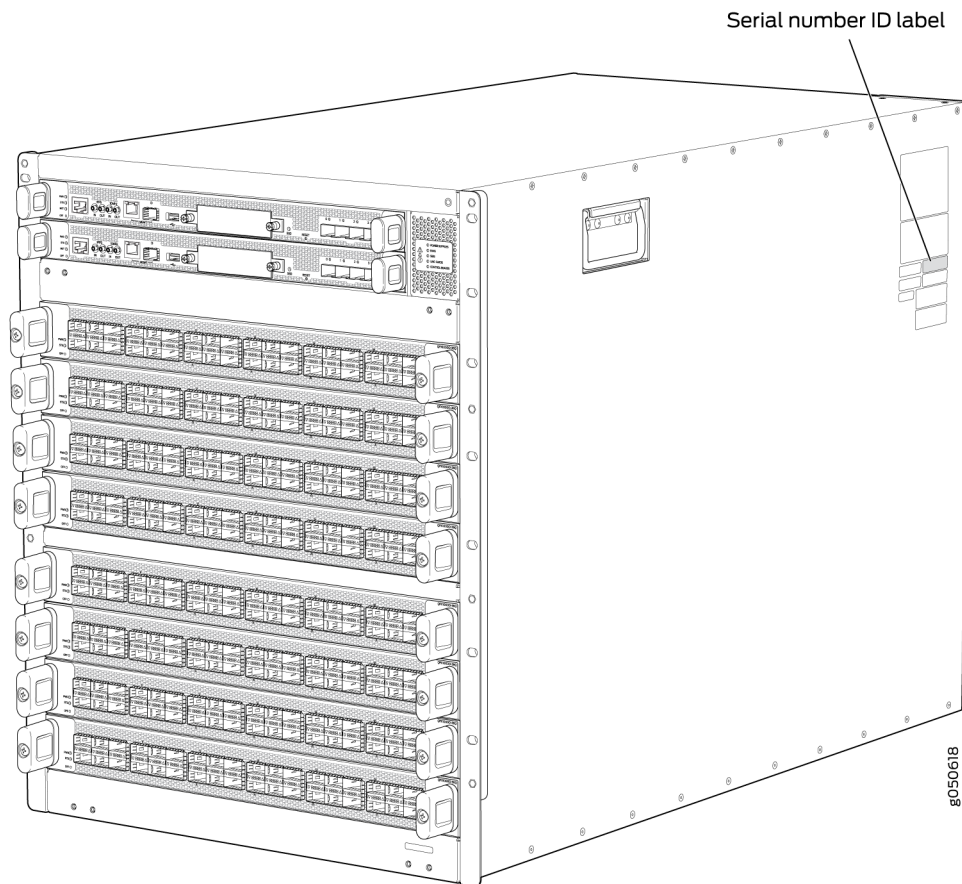
```

Unit				
PSM 2	Rev 02	740-069994	1F219110456	JNP10K 5500W AC/HVDC Power Supply
Unit				
PSM 3	Rev 02	740-069994	1F219110340	JNP10K 5500W AC/HVDC Power Supply
Unit				
PSM 4	Rev 02	740-069994	1F219110310	JNP10K 5500W AC/HVDC Power Supply
Unit				
PSM 5	Rev 02	740-069994	1F219110329	JNP10K 5500W AC/HVDC Power Supply
Unit				
Routing Engine 0		BUILTIN	BUILTIN	JNP10K-RE1-E
Routing Engine 1		BUILTIN	BUILTIN	JNP10K-RE1-E
CB 0	REV 14	750-079562	CAKY1871	Control Board
CB 1	REV 14	750-079562	CAKY1881	Control Board
FPC 0	REV 07	750-093524	BCBA1286	JNP10K-LC1201
CPU	REV 03	711-072984	CALJ4961	JNP10K-LC1201 PMB Board
PIC 0		BUILTIN	BUILTIN	JNP10K-36QDD-LC-PIC
Xcvr 0	XXXX	NON-JNPR	1829730235	QSFP56-DD-400G-CR8-CU-1M
Xcvr 1	REV 01	720-087756	1J1C45A414100	QSFP56-DD-400G-CR8-CU-1M
Xcvr 2	REV 01	720-087756	1J1C45A414100	QSFP56-DD-400G-CR8-CU-1M
Xcvr 3	REV 01	720-087756	1J1C45A414048	QSFP56-DD-400G-CR8-CU-1M
Xcvr 4	REV 01	720-087756	1J1C45A414048	QSFP56-DD-400G-CR8-CU-1M
Xcvr 5	REV 01	720-087756	1J1C45A414107	QSFP56-DD-400G-CR8-CU-1M
MEZZ 0	REV 03	711-084968	BCAY0470	JNP10K-LC1201 MEZZ Board
FPC 1	REV 07	750-093524	BCAY8271	JNP10K-LC1201
CPU	REV 03	711-072984	CALJ4968	JNP10K-LC1201 PMB Board
PIC 0		BUILTIN	BUILTIN	JNP10K-36QDD-LC-PIC
Xcvr 32	REV 01	720-087756	1J1C45A414140	QSFP56-DD-400G-CR8-CU-1M
Xcvr 33	REV 01	720-087756	1J1C45A414137	QSFP56-DD-400G-CR8-CU-1M
Xcvr 34	REV 01	720-087756	1J1C45A414137	QSFP56-DD-400G-CR8-CU-1M
Xcvr 35	XXXX	NON-JNPR	1829730171	QSFP56-DD-400G-CR8-CU-1M
MEZZ 0	REV 03	711-084968	CALS8492	JNP10K-LC1201 MEZZ Board
FPC 2	REV 07	750-093524	BCAZ2821	JNP10K-LC1201
CPU	REV 03	711-072984	BCAY0404	JNP10K-LC1201 PMB Board
PIC 0		BUILTIN	BUILTIN	JNP10K-36QDD-LC-PIC
MEZZ 0	REV 03	711-084968	BCAY0449	JNP10K-LC1201 MEZZ Board
FPC 3	REV 07	750-093524	BCAY8286	JNP10K-LC1201
CPU	REV 03	711-072984	CALJ4944	JNP10K-LC1201 PMB Board
PIC 0		BUILTIN	BUILTIN	JNP10K-36QDD-LC-PIC
FPC 4	REV 07	750-093524	BCAY8278	JNP10K-LC1201
CPU	REV 03	711-072984	CALJ4964	JNP10K-LC1201 PMB Board
PIC 0		BUILTIN	BUILTIN	JNP10K-36QDD-LC-PIC
MEZZ 0	REV 03	711-084968	CALS8503	JNP10K-LC1201 MEZZ Board
FPC 6	REV 07	750-093524	BCBA1277	JNP10K-LC1201

CPU	REV 03	711-072984	BCAY0388	JNP10K-LC1201 PMB Board
PIC 0		BUILTIN	BUILTIN	JNP10K-36QDD-LC-PIC
MEZZ 0	REV 03	711-084968	BCAY0456	JNP10K-LC1201 MEZZ Board
FPC 7	REV 07	750-093524	BCAY8288	JNP10K-LC1201
CPU	REV 03	711-072984	BCAW3545	JNP10K-LC1201 PMB Board
PIC 0		BUILTIN	BUILTIN	JNP10K-36QDD-LC-PIC
MEZZ 0	REV 03	711-084968	CALS8484	JNP10K-LC1201 MEZZ Board
SIB 0	REV 11	750-083423	BCAY0351	SIB-JNP10008
SIB 1	REV 06	750-083423	BCAN8992	SIB-JNP10008
SIB 2	REV 11	750-083423	BCAY0349	SIB-JNP10008
SIB 3	REV 06	750-083423	BCAN8990	SIB-JNP10008
SIB 4	REV 06	750-083423	BCAP3582	SIB-JNP10008
SIB 5	REV 06	750-083423	BCAP3563	SIB-JNP10008
FTC 0	REV 02	750-083435	BCAJ6881	Fan Controller 8
FTC 1	REV 02	750-083435	BCAJ3351	Fan Controller 8
Fan Tray 0	REV 05	760-086563	BCAF4564	Fan Tray 8
Fan Tray 1	REV 05	760-086563	BCAF4569	Fan Tray 8

Locate the Chassis Serial Number ID Label on a PTX10008

The serial number ID label is located on a label on the right side of the chassis. See [Figure 214 on page 470](#) for the location on a PTX10008.

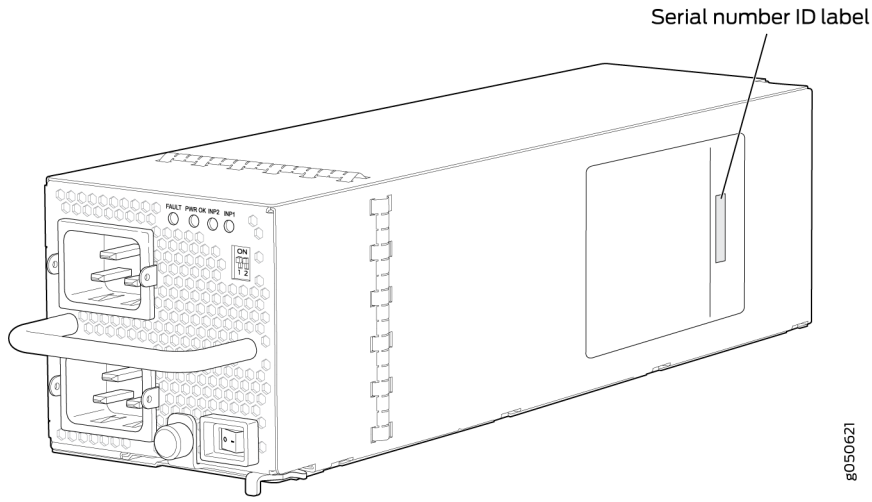
Figure 214: PTX10008 Serial Number Label

Locate the Serial Number ID Labels on PTX10008 Power Supplies

The power supplies installed in a PTX10008 are field-replaceable units (FRUs). For each FRU, you must remove the FRU from the router chassis to see the FRU serial number ID label.

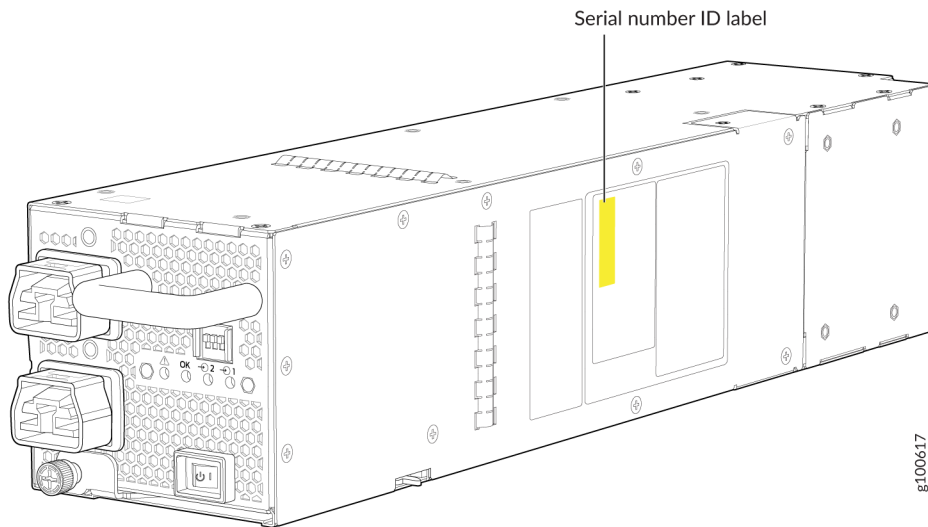
- JNP10K-PWR-AC power supply—The serial number ID label is on the right side of the JNP10K-PWR-AC power supply. See [Figure 215 on page 471](#).

Figure 215: JNP10K-PWR-AC Power Supply Serial Number Location



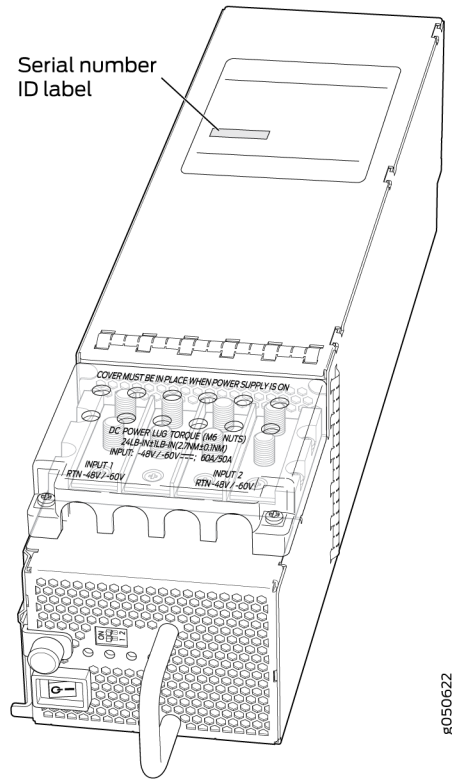
- JNP10K-PWR-AC2 power supply—The serial ID label is on the right side of the power supply. See [Figure 216 on page 471](#).

Figure 216: JNP10K-PWR-AC2 Power Supply Serial Number Location



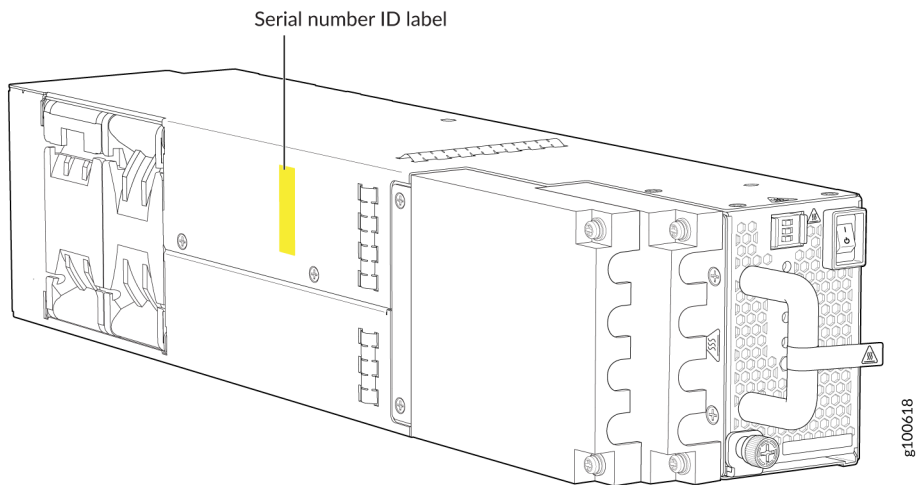
- JNP10K-PWR-DC power supply—The serial number ID label is on the left side of the DC power supply. See [Figure 217 on page 472](#).

Figure 217: JNP10K-PWR DC Power Supply Serial Number Location



- JNP10K-PWR-DC2 power supply—The serial number ID label is on the left side of the power supply. See [Figure 218 on page 472](#).

Figure 218: JNP10K-PWR-DC2 Power Supply Serial Number Location

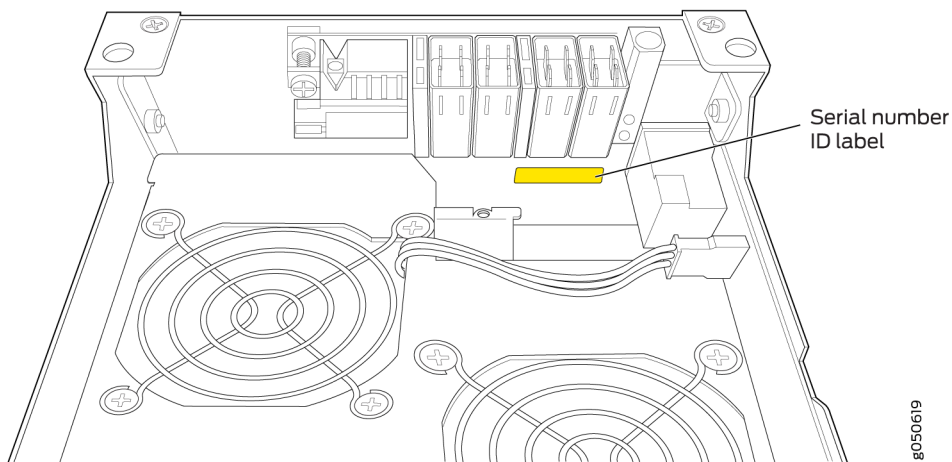


Locate the Serial Number ID Labels on PTX10008 Fan Trays and Fan Tray Controllers

The two fan trays and their associated fan tray controllers installed in a PTX10008 are field-replaceable units (FRUs). For each FRU, you must remove the FRU from the router chassis to see the FRU serial number ID label.

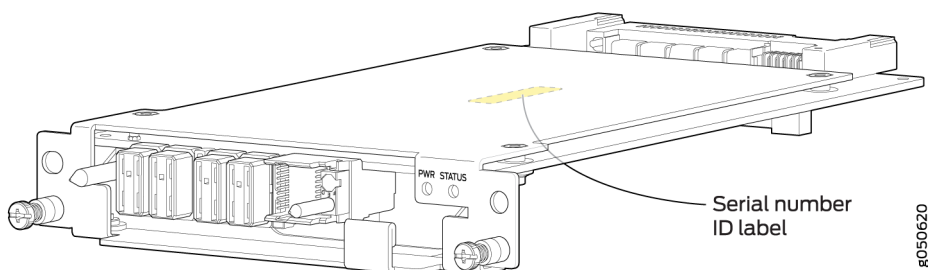
- Fan tray—The serial number ID label for all fan tray models (JNP10008-FAN and JNP10008-FAN2) is located on the inside of the fan tray at the base of the fan tray Control Board. See [Figure 219 on page 473](#).

Figure 219: PTX10008 Fan Tray Serial Number Location



- Fan tray controller—The serial number ID label for all fan tray controller models (JNP10008-FAN-CTRL and JNP10008-FTC2) is located on the top of the fan tray controller. See [Figure 220 on page 473](#).

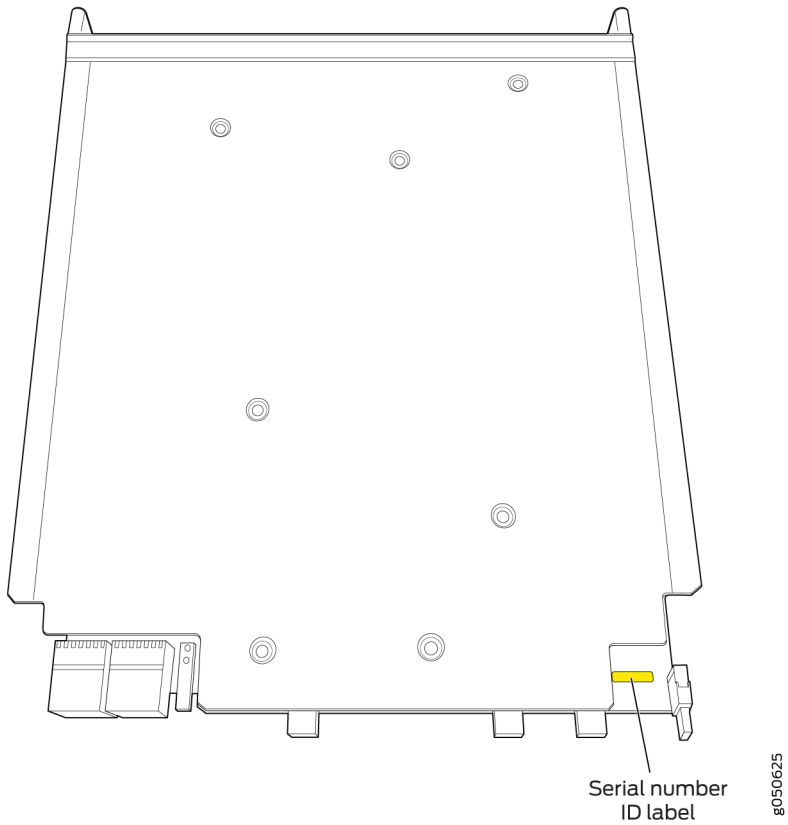
Figure 220: PTX10008 Fan Tray Controller Serial Number Location



Locate the Serial Number ID Labels on PTX10008 Routing and Control Boards

The serial number ID label for a Routing and Control Board (RCB) is located on the connector end of the unit. See [Figure 221 on page 474](#).

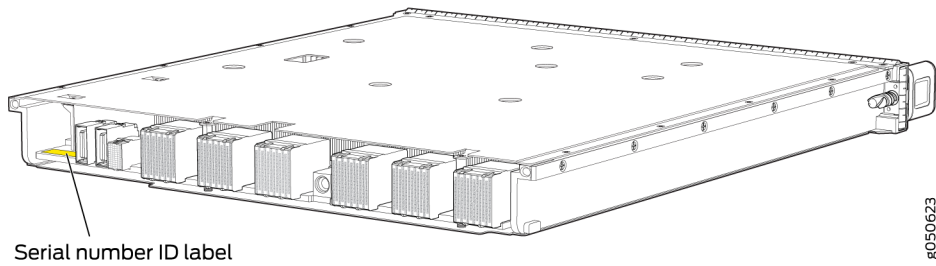
Figure 221: PTX10008 Routing and Control Board Serial Number Location



Locate the Serial Number ID Labels on a PTX10008 Line Card

The serial number ID label for a line card is located on the connector end of the card. See [Figure 222 on page 475](#).

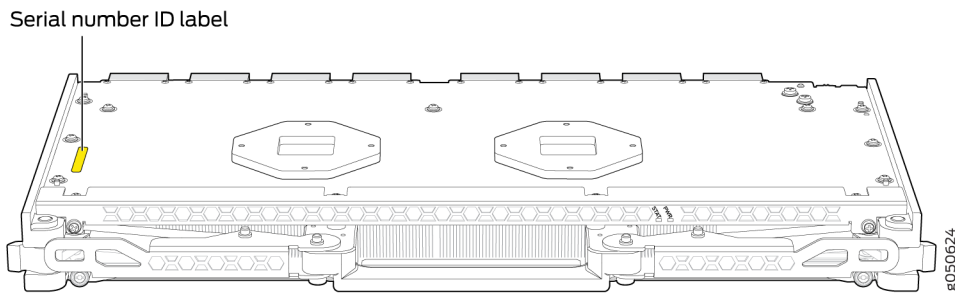
Figure 222: PTX10008 Line Card Serial Number Location



Locate the Serial Number ID Labels on a PTX10008 Switch Interface Board (SIB)

The serial number ID label for a SIB is located on the printed circuit board. See [Figure 223 on page 475](#).

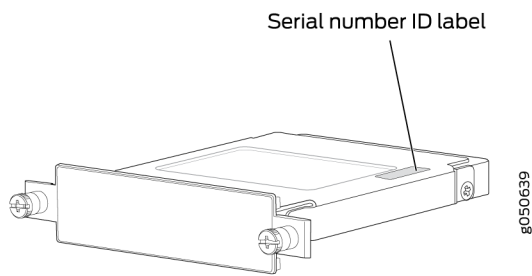
Figure 223: PTX10008 SIB Serial Number Location



Locate the Serial Number ID Label on a PTX10008 SATA SSD

The serial number for a SATA SSD is located on top of the drive. See [Figure 224 on page 475](#).

Figure 224: PTX10008 SATA SSD Serial Number Location



RELATED DOCUMENTATION

[PTX10008 Hardware Overview](#) | 15

Contact Customer Support to Obtain a Return Materials Authorization for a PTX10008 Router or Component

If you are returning a PTX10008 router or component to Juniper Networks for repair or replacement, you must first obtain a Return Materials Authorization (RMA) from the Juniper Networks Technical Assistance Center (JTAC).

After locating the serial number of the device or component you want to return, open a service request with Juniper Networks Technical Assistance Center (JTAC) on the Web or by telephone.

For instructions on locating the serial number of the device or component you want to return, see the following device instructions:

- ["Locate the Serial Number on a PTX10008 Router or Component" on page 465](#)

Before you request an RMA from JTAC, be prepared to provide the following information:

- Your existing service request number, if you have one
- Serial number of the component
- Your name, organization name, telephone number, fax number, and shipping address
- Details of the failure or problem
- Type of activity being performed on the device when the problem occurred
- Configuration data displayed by one or more `show` commands

You can contact JTAC 24 hours a day, seven days a week on the Web or by telephone:

- Service Request Manager: <https://support.juniper.net/support/>
- Telephone: +1-888-314-JTAC (+1-888-314-5822), toll-free in the USA, Canada, and Mexico

NOTE: For international or direct-dial options in countries without toll-free numbers, see <https://www.juniper.net/support/requesting-support.html>.

If you are contacting JTAC by telephone, enter your 12-digit service request number followed by the pound (#) key for an existing case, or press the star (*) key to be routed to the next available support engineer.

The support representative validates your request and issues an RMA number for return of the component.

How to Pack a PTX10008 or Component for Shipping

IN THIS SECTION

- [How to Pack a PTX10008 Chassis for Shipping | 478](#)
- [How to Pack PTX10008 Components for Shipping | 480](#)

Follow this procedure if you are returning a PTX10008 chassis or component to Juniper Networks for repair or replacement.

Before you pack a PTX10008 or component:

- Ensure that you have taken the necessary precautions to prevent electrostatic discharge (ESD) damage. See *Prevention of Electrostatic Discharge Damage*.
- Pack your chassis or component using one of these materials:
 - Use the packing material from the replacement chassis or component
 - Retrieve the original shipping carton and packing materials

Contact your JTAC representative if you do not have these materials, to learn about approved packing materials. See "[Contact Customer Support to Obtain a Return Materials Authorization for a PTX10008 Router or Component](#)" on page 476.

Ensure that you have the following parts and tools available:

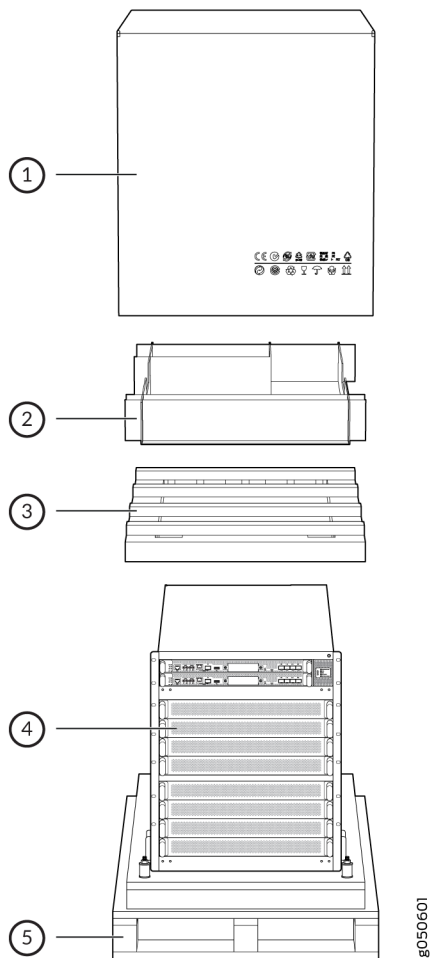
- ESD grounding strap.
- Electrostatic bag, one for each component.
- If you are returning the chassis:

- A 13/32-in. or 10-mm open-end or socket wrench to install the bracket bolts on the chassis and shipping pallet
- An appropriate screwdriver for the mounting screws used on your rack.

How to Pack a PTX10008 Chassis for Shipping

The PTX10008 is shipped in a cardboard box that has a two-layer wooden pallet base with foam cushioning between the layers. The router chassis is bolted to the pallet base with four pallet fasteners, two on each side of the chassis. See Figure 12 for the stacking configuration of the PTX10008.

Figure 225: Stacking Configuration for Packing the PTX10008 Chassis

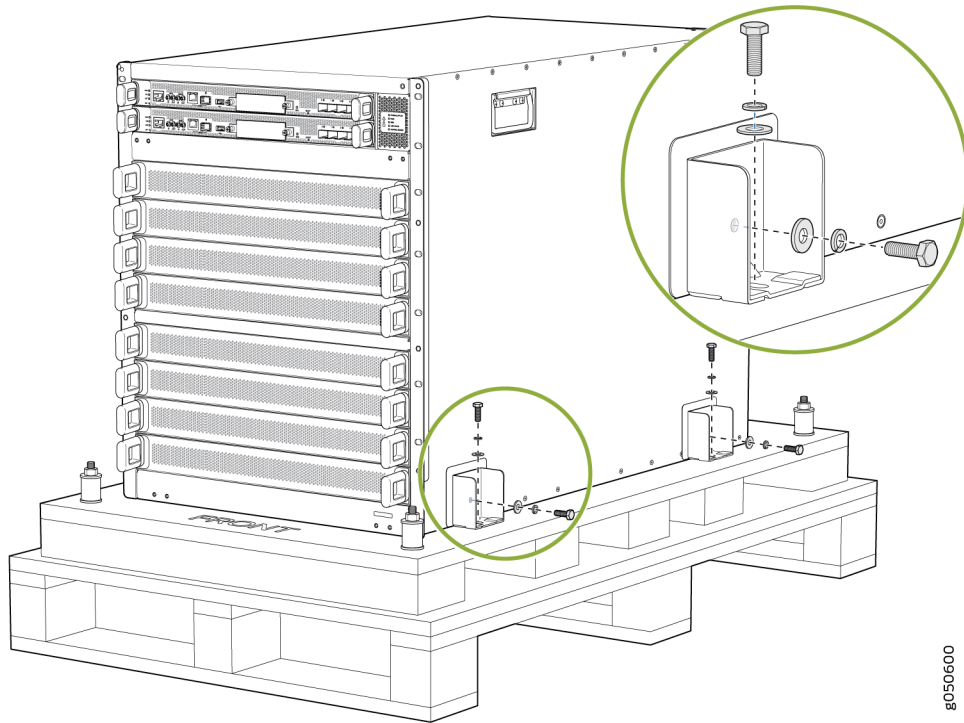


To pack a PTX10008 for shipping:

1. Power down the chassis and remove the power cables. See "[Power Off a PTX10008](#)" on page 449.
2. Remove the cables that connect the PTX10008 to all external devices.

3. Remove all line cards and pack them in their original shipping containers. See ["How to Pack a PTX10008 or Component for Shipping" on page 477](#).
4. Install covers over blank slots.
Leave components that came installed in the chassis, such as the Routing Control Boards or power supplies.
5. Move the wooden pallet and packing material to a staging area as close to the router as possible. Make sure there is enough space to move the chassis from the rack to the wooden pallet.
6. Position a mechanical lift under the device. If a mechanical lift is not available, have three people support the weight of the router while another person uses the screwdriver to remove the front mounting screws that attach the chassis mounting brackets to the rack. For PTX10008 removal, see ["Remove a PTX10008 from a Four-Post Rack Using a Mechanical Lift" on page 452](#) or ["Remove a PTX10008 Manually from a Four-Post Rack" on page 454](#).
7. Remove the router from the rack (see ["PTX10008 Chassis Lifting Guidelines" on page 490](#)) and place the router on the shipping pallet. Position the router on the pallet so that the front of the router is facing the silkscreened "front" mark on the pallet. The pallet also has crop marks to guide you in positioning the chassis.
8. Use the 13/32-in. or 10-mm open-end or socket wrench to install the four sets of brackets and bolts that secure the chassis to the wooden pallet.
9. Slide the plastic cover over the router chassis. The plastic cover is part of the router's original packing materials.
10. Place the packing foam on top of and around the router.
11. Place the power cords in the box.
12. Remove the rack mount kit from the rack and place it and the connecting screws in the accessory box.
13. If you are returning accessories or FRUs with the router, pack them as instructed in ["How to Pack a PTX10008 or Component for Shipping" on page 477](#).
14. Verify that all accessories are present. See ["Compare the PTX10008 Order to the Packing List" on page 285](#).
15. Slide the cardboard box over the chassis, making sure that the arrows on the box point up and the pallet fasteners to secure the cardboard box to the wooden pallet are near the bottom.
16. Attach the cardboard box to the wooden pallet by screwing two screws into each of the four pallet fasteners. See Figure 13.

Figure 226: Attach the PTX10008 to the Pallet



0090508

17. Write the RMA number on the exterior of the box to ensure proper tracking.

How to Pack PTX10008 Components for Shipping

Before you begin packing a router component, ensure that you have the following parts and tools available:

- Antistatic bag, one for each component
- Electrostatic discharge (ESD) grounding strap



CAUTION: Do not stack router components. Return individual components in separate boxes if they do not fit together on one level in the shipping box.

To pack and ship PTX10008 components:

1. Place individual FRUs in antistatic bags.
2. Use the original packing materials if they are available. If the original packing materials are not available, ensure the component is adequately packed to prevent damage during transit. The packing material you use must be able to support the weight of the component.
3. Ensure that the components are adequately protected with packing materials and packed so that the pieces are prevented from moving around inside the carton.

4. Close the top of the cardboard shipping box and seal it with packing tape.
5. Write the RMA number on the exterior of the box to ensure proper tracking.

RELATED DOCUMENTATION

[PTX10008 Hardware Overview | 15](#)

[How to Pack a PTX10008 or Component for Shipping | 477](#)

9

CHAPTER

Safety and Compliance Information

General Safety Guidelines and Warnings | 484

Definitions of Safety Warning Levels | 485

Qualified Personnel Warning | 487

Warning Statement for Norway and Sweden | 487

Fire Safety Requirements | 488

Installation Instructions Warning | 489

PTX10008 Chassis Lifting Guidelines | 490

Restricted Access Warning | 490

Ramp Warning | 492

Rack-Mounting and Cabinet-Mounting Warnings | 492

Grounded Equipment Warning | 496

Radiation from Open Port Apertures Warning | 497

Laser and LED Safety Guidelines and Warnings | 498

Maintenance and Operational Safety Guidelines and Warnings | 501

General Electrical Safety Guidelines and Warnings | 507

Action to Take After an Electrical Accident | 508

Prevention of Electrostatic Discharge Damage | 509

AC Power Electrical Safety Guidelines | 510

AC Power Disconnection Warning | 511

DC Power Electrical Safety Guidelines for the PTX10008 and PTX10016 Routers | 512

DC Power Copper Conductors Warning | 513

DC Power Disconnection Warning | 514

DC Power Grounding Requirements and Warning | 515

DC Power Wiring Sequence Warning | 516

DC Power Wiring Terminations Warning | 518

Multiple Power Supplies Disconnection Warning | 519

TN Power Warning | 520

PTX10008 and PTX10016 Agency Approvals and Compliance Statements | 521

General Safety Guidelines and Warnings

The following guidelines help ensure your safety and protect the device from damage. The list of guidelines might not address all potentially hazardous situations in your working environment, so be alert and exercise good judgment at all times.

- Perform only the procedures explicitly described in the hardware documentation for this device. Make sure that only authorized service personnel perform other system services.
- Keep the area around the device clear and free from dust before, during, and after installation.
- Keep tools away from areas where people could trip over them while walking.
- Do not wear loose clothing or jewelry, such as rings, bracelets, or chains, which could become caught in the device.
- Wear safety glasses if you are working under any conditions that could be hazardous to your eyes.
- Do not perform any actions that create a potential hazard to people or make the equipment unsafe.
- Never attempt to lift an object that is too heavy for one person to handle.
- Never install or manipulate wiring during electrical storms.
- Never install electrical jacks in wet locations unless the jacks are specifically designed for wet environments.
- Operate the device only when it is properly grounded.
- Follow the instructions in this guide to properly ground the device to earth.
- Replace fuses only with fuses of the same type and rating.
- Do not open or remove chassis covers or sheet-metal parts unless instructions are provided in the hardware documentation for this device. Such an action could cause severe electrical shock.
- Do not push or force any objects through any opening in the chassis frame. Such an action could result in electrical shock or fire.
- Avoid spilling liquid onto the chassis or onto any device component. Such an action could cause electrical shock or damage the device.
- Avoid touching uninsulated electrical wires or terminals that have not been disconnected from their power source. Such an action could cause electrical shock.

- Some parts of the chassis, including AC and DC power supply surfaces, power supply unit handles, SFB card handles, and fan tray handles might become hot. The following label provides the warning for hot surfaces on the chassis:



- Always ensure that all modules, power supplies, and cover panels are fully inserted and that the installation screws are fully tightened.

Definitions of Safety Warning Levels

The documentation uses the following levels of safety warnings (there are two *Warning* formats):

NOTE: You might find this information helpful in a particular situation, or you might overlook this important information if it was not highlighted in a Note.



CAUTION: You need to observe the specified guidelines to prevent minor injury or discomfort to you or severe damage to the device.

Attention Veillez à respecter les consignes indiquées pour éviter toute incommodité ou blessure légère, voire des dégâts graves pour l'appareil.



LASER WARNING: This symbol alerts you to the risk of personal injury from a laser.

Avertissement Ce symbole signale un risque de blessure provoquée par rayon laser.



WARNING: This symbol means danger. You are in a situation that could cause bodily injury. Before you work on any equipment, be aware of the hazards involved with electrical circuitry, and familiarize yourself with standard practices for preventing accidents.

Waarschuwing Dit waarschuwingssymbool betekent gevaar. U verkeert in een situatie die lichamelijk letsel kan veroorzaken. Voordat u aan enige apparatuur gaat werken, dient u zich bewust te zijn van de bij elektrische schakelingen betrokken risico's en dient u op de hoogte te zijn van standaard maatregelen om ongelukken te voorkomen.

Varoitus Tämä varoitusmerkki merkitsee vaaraa. Olet tilanteessa, joka voi johtaa ruumiinvammaan. Ennen kuin työskentelet minkään laitteiston parissa, ota selvää sähkökytkentöihin liittyvistä vaaroista ja tavanomaisista onnettomuuksien ehkäisykeinoista.

Avertissement Ce symbole d'avertissement indique un danger. Vous vous trouvez dans une situation pouvant causer des blessures ou des dommages corporels. Avant de travailler sur un équipement, soyez conscient des dangers posés par les circuits électriques et familiarisez-vous avec les procédures couramment utilisées pour éviter les accidents.

Warnung Dieses Warnsymbol bedeutet Gefahr. Sie befinden sich in einer Situation, die zu einer Körperverletzung führen könnte. Bevor Sie mit der Arbeit an irgendeinem Gerät beginnen, seien Sie sich der mit elektrischen Stromkreisen verbundenen Gefahren und der Standardpraktiken zur Vermeidung von Unfällen bewußt.

Avvertenza Questo simbolo di avvertenza indica un pericolo. La situazione potrebbe causare infortuni alle persone. Prima di lavorare su qualsiasi apparecchiatura, occorre conoscere i pericoli relativi ai circuiti elettrici ed essere al corrente delle pratiche standard per la prevenzione di incidenti.

Advarsel Dette varselsymbolet betyr fare. Du befinner deg i en situasjon som kan føre til personskade. Før du utfører arbeid på utstyr, må du være oppmerksom på de faremomentene som elektriske kretser innebærer, samt gjøre deg kjent med vanlig praksis når det gjelder å unngå ulykker.

Aviso Este símbolo de aviso indica perigo. Encontra-se numa situação que lhe poderá causar danos físicos. Antes de começar a trabalhar com qualquer equipamento, familiarize-se com os perigos relacionados com circuitos eléctricos, e com quaisquer práticas comuns que possam prevenir possíveis acidentes.

¡Atención! Este símbolo de aviso significa peligro. Existe riesgo para su integridad física. Antes de manipular cualquier equipo, considerar los riesgos que entraña la corriente eléctrica y familiarizarse con los procedimientos estándar de prevención de accidentes.

Varning! Denna varningssymbol signalerar fara. Du befinner dig i en situation som kan leda till personskada. Innan du utför arbete på någon utrustning måste du vara medveten om farorna med elkretsar och känna till vanligt förfarande för att förebygga skador.

Qualified Personnel Warning



WARNING: Only trained and qualified personnel should install or replace the device.

Waarschuwing Installatie en reparaties mogen uitsluitend door getraind en bevoegd personeel uitgevoerd worden.

Varoitus Ainoastaan koulutettu ja pätevä henkilökunta saa asentaa tai vaihtaa tämän laitteen.

Avertissement Tout installation ou remplacement de l'appareil doit être réalisé par du personnel qualifié et compétent.

Warnung Gerät nur von geschultem, qualifiziertem Personal installieren oder auswechseln lassen.

Avvertenza Solo personale addestrato e qualificato deve essere autorizzato ad installare o sostituire questo apparecchio.

Advarsel Kun kvalifisert personell med riktig opplæring bør montere eller bytte ut dette utstyret.

Aviso Este equipamento deverá ser instalado ou substituído apenas por pessoal devidamente treinado e qualificado.

¡Atención! Estos equipos deben ser instalados y reemplazados exclusivamente por personal técnico adecuadamente preparado y capacitado.

Varning! Denna utrustning ska endast installeras och bytas ut av utbildad och kvalificerad personal.

Warning Statement for Norway and Sweden



WARNING: The equipment must be connected to an earthed mains socket-outlet.

Advarsel Apparatet skal kobles til en jordet stikkontakt.

Varning! Apparaten skall anslutas till jordat nätuttag.

Fire Safety Requirements

IN THIS SECTION

- [Fire Suppression | 488](#)
- [Fire Suppression Equipment | 488](#)

In the event of a fire emergency, the safety of people is the primary concern. You should establish procedures for protecting people in the event of a fire emergency, provide safety training, and properly provision fire-control equipment and fire extinguishers.

In addition, you should establish procedures to protect your equipment in the event of a fire emergency. Juniper Networks products should be installed in an environment suitable for electronic equipment. We recommend that fire suppression equipment be available in the event of a fire in the vicinity of the equipment and that all local fire, safety, and electrical codes and ordinances be observed when you install and operate your equipment.

Fire Suppression

In the event of an electrical hazard or an electrical fire, you should first turn power off to the equipment at the source. Then use a Type C fire extinguisher, which uses noncorrosive fire retardants, to extinguish the fire.

Fire Suppression Equipment

Type C fire extinguishers, which use noncorrosive fire retardants such as carbon dioxide and Halotron™, are most effective for suppressing electrical fires. Type C fire extinguishers displace oxygen from the point of combustion to eliminate the fire. For extinguishing fire on or around equipment that draws air from the environment for cooling, you should use this type of inert oxygen displacement extinguisher instead of an extinguisher that leaves residues on equipment.

Do not use multipurpose Type ABC chemical fire extinguishers (dry chemical fire extinguishers). The primary ingredient in these fire extinguishers is monoammonium phosphate, which is very sticky and

difficult to clean. In addition, in the presence of minute amounts of moisture, monoammonium phosphate can become highly corrosive and corrodes most metals.

Any equipment in a room in which a chemical fire extinguisher has been discharged is subject to premature failure and unreliable operation. The equipment is considered to be irreparably damaged.

NOTE: To keep warranties effective, do not use a dry chemical fire extinguisher to control a fire at or near a Juniper Networks device. If a dry chemical fire extinguisher is used, the unit is no longer eligible for coverage under a service agreement.

We recommend that you dispose of any irreparably damaged equipment in an environmentally responsible manner.

Installation Instructions Warning



WARNING: Read the installation instructions before you connect the device to a power source.

Waarschuwing Raadpleeg de installatie-aanwijzingen voordat u het systeem met de voeding verbindt.

Varoitus Lue asennusohjeet ennen järjestelmän yhdistämistä virtälähteeseen.

Avertissement Avant de brancher le système sur la source d'alimentation, consulter les directives d'installation.

Warnung Lesen Sie die Installationsanweisungen, bevor Sie das System an die Stromquelle anschließen.

Avvertenza Consultare le istruzioni di installazione prima di collegare il sistema all'alimentatore.

Advarsel Les installasjonsinstruksjonene før systemet kobles til strømkilden.

Aviso Leia as instruções de instalação antes de ligar o sistema à sua fonte de energia.

¡Atención! Ver las instrucciones de instalación antes de conectar el sistema a la red de alimentación.

Varning! Läs installationsanvisningarna innan du kopplar systemet till dess strömförsörjningsenhet.

PTX10008 Chassis Lifting Guidelines

The weight of a chassis varies by the configuration. A chassis spare is the lightest at 273 lb (123.8 kg) and the weight goes up to 421 lb (191 kg) on the PTX10008-PREM3. Installing the PTX10008 router in a rack or cabinet requires either a mechanical lift or three people to lift the router and another person to secure it to the rack. To prevent injury, keep your back straight and lift with your legs, not your back.



CAUTION: If you are installing the PTX10008 without a mechanical lift, remove all power supplies, control boards, SIBs, cover panels, and fan trays before attempting to install the router. Unless you are using a mechanical lift, at least three people are required to perform the rack installation.

- Before installing a PTX10008, read the guidelines in "[PTX10008 Site Preparation Checklist](#)" on page 197 to verify that the intended site meets the specified power, environmental, and clearance requirements.
- Before lifting or moving the PTX10008, disconnect all external cables.
- When raising the PTX10008 into the rack, have two people lift and align the router with the rack while another person secures the router to the rack. As when lifting any heavy object, lift most of the weight with your legs rather than your back. Keep your knees bent and your back relatively straight and avoid twisting your body as you lift. Balance the load evenly and be sure that your footing is solid.

RELATED DOCUMENTATION

[Mount the PTX10008 by Using the JNP10004-RMK-4POST Rack Mount Kit | 291](#)

[Mount the PTX10008 by Using the EX-MOD-RMK-4POST Rack Mount Kit | 298](#)

Restricted Access Warning



WARNING: This unit is intended for installation in restricted access areas. A restricted access area is an area to which access can be gained only by service personnel through the use of a special tool, lock and key, or other means of security, and which is controlled by the authority responsible for the location.

Waarschuwing Dit toestel is bedoeld voor installatie op plaatsen met beperkte toegang. Een plaats met beperkte toegang is een plaats waar toegang slechts door servicepersoneel verkregen kan worden door middel van een speciaal instrument, een slot en sleutel, of een ander veiligheidsmiddel, en welke beheerd wordt door de overheidsinstantie die verantwoordelijk is voor de locatie.

Varoitus Tämä laite on tarkoitettu asennettavaksi paikkaan, johon pääsy on rajoitettua. Paikka, johon pääsy on rajoitettua, tarkoittaa paikkaa, johon vain huoltohenkilöstö pääsee jonkin erikoistyökalun, lukkoon sopivan avaimen tai jonkin muun turvalaitteen avulla ja joka on paikasta vastuussa olevien toimivaltaisten henkilöiden valvoma.

Avertissement Cet appareil est à installer dans des zones d'accès réservé. Ces dernières sont des zones auxquelles seul le personnel de service peut accéder en utilisant un outil spécial, un mécanisme de verrouillage et une clé, ou tout autre moyen de sécurité. L'accès aux zones de sécurité est sous le contrôle de l'autorité responsable de l'emplacement.

Warnung Diese Einheit ist zur Installation in Bereichen mit beschränktem Zutritt vorgesehen. Ein Bereich mit beschränktem Zutritt ist ein Bereich, zu dem nur Wartungspersonal mit einem Spezialwerkzeugs, Schloß und Schlüssel oder anderer Sicherheitsvorkehrungen Zugang hat, und der von dem für die Anlage zuständigen Gremium kontrolliert wird.

Avvertenza Questa unità deve essere installata in un'area ad accesso limitato. Un'area ad accesso limitato è un'area accessibile solo a personale di assistenza tramite un'attrezzo speciale, lucchetto, o altri dispositivi di sicurezza, ed è controllata dall'autorità responsabile della zona.

Advarsel Denne enheten er laget for installasjon i områder med begrenset adgang. Et område med begrenset adgang gir kun adgang til servicepersonale som bruker et spesielt verktøy, lås og nøkkel, eller en annen sikkerhetsanordning, og det kontrolleres av den autoriteten som er ansvarlig for området.

Aviso Esta unidade foi concebida para instalação em áreas de acesso restrito. Uma área de acesso restrito é uma área à qual apenas tem acesso o pessoal de serviço autorizado, que possua uma ferramenta, chave e fechadura especial, ou qualquer outra forma de segurança. Esta área é controlada pela autoridade responsável pelo local.

¡Atención! Esta unidad ha sido diseñada para instalarse en áreas de acceso restringido. Área de acceso restringido significa un área a la que solamente tiene acceso el personal de servicio mediante la utilización de una herramienta especial, cerradura con llave, o algún otro medio de seguridad, y que está bajo el control de la autoridad responsable del local.

Warning! Denna enhet är avsedd för installation i områden med begränsat tillträde. Ett område med begränsat tillträde får endast tillträdas av servicepersonal med ett speciellt verktyg, lås och nyckel, eller annan säkerhetsanordning, och kontrolleras av den auktoritet som ansvarar för området.

Ramp Warning



WARNING: When installing the device, do not use a ramp inclined at more than 10 degrees.

Waarschuwing Gebruik een oprijplaat niet onder een hoek van meer dan 10 graden.

Varoitus Älä käytä sellaista kaltevaa pintaa, jonka kaltevuus ylittää 10 astetta.

Avertissement Ne pas utiliser une rampe dont l'inclinaison est supérieure à 10 degrés.

Warnung Keine Rampen mit einer Neigung von mehr als 10 Grad verwenden.

Avvertenza Non usare una rampa con pendenza superiore a 10 gradi.

Advarsel Bruk aldri en rampe som heller mer enn 10 grader.

Aviso Não utilize uma rampa com uma inclinação superior a 10 graus.

¡Atención! No usar una rampa inclinada más de 10 grados.

Warning! Använd inte ramp med en lutning på mer än 10 grader.

Rack-Mounting and Cabinet-Mounting Warnings

Ensure that the rack or cabinet in which the device is installed is evenly and securely supported. Uneven mechanical loading could lead to a hazardous condition.



WARNING: To prevent bodily injury when mounting or servicing the device in a rack, take the following precautions to ensure that the system remains stable. The following directives help maintain your safety:

- Install the device in a rack that is secured to the building structure.
- Mount the device at the bottom of the rack if it is the only unit in the rack.
- When mounting the device on a partially filled rack, load the rack from the bottom to the top, with the heaviest component at the bottom of the rack.
- If the rack is provided with stabilizing equipment, install the stabilizers before mounting or servicing the device in the rack.

Waarschuwing Om lichamelijk letsel te voorkomen wanneer u dit toestel in een rek monteert of het daar een servicebeurt geeft, moet u speciale voorzorgsmaatregelen nemen om ervoor te zorgen dat het toestel stabiel blijft. De onderstaande richtlijnen worden verstrekt om uw veiligheid te verzekeren:

- De Juniper Networks switch moet in een stellage worden geïnstalleerd die aan een bouwsel is verankerd.
- Dit toestel dient onderaan in het rek gemonteerd te worden als het toestel het enige in het rek is.
- Wanneer u dit toestel in een gedeeltelijk gevuld rek monteert, dient u het rek van onderen naar boven te laden met het zwaarste onderdeel onderaan in het rek.
- Als het rek voorzien is van stabiliseringshulpmiddelen, dient u de stabilisatoren te monteren voordat u het toestel in het rek monteert of het daar een servicebeurt geeft.

Varoitus Kun laite asetetaan telineeseen tai huolletaan sen ollessa telineessä, on noudatettava erityisiä varotoimia järjestelmän vakavuuden säilyttämiseksi, jotta vältetään loukkaantumiselta. Noudata seuraavia turvallisuusohjeita:

- Juniper Networks switch on asennettava telineeseen, joka on kiinnitetty rakennukseen.
- Jos telineessä ei ole muita laitteita, aseta laite telineen alaosaan.
- Jos laite asetetaan osaksi täytettyyn telineeseen, aloita kuormittaminen sen alaosasta kaikkein raskaimmalla esineellä ja siirry sitten sen yläosaan.
- Jos telinettä varten on vakaimet, asenna ne ennen laitteen asettamista telineeseen tai sen huoltamista siinä.

Avertissement Pour éviter toute blessure corporelle pendant les opérations de montage ou de réparation de cette unité en casier, il convient de prendre des précautions

spéciales afin de maintenir la stabilité du système. Les directives ci-dessous sont destinées à assurer la protection du personnel:

- Le rack sur lequel est monté le Juniper Networks switch doit être fixé à la structure du bâtiment.
- Si cette unité constitue la seule unité montée en casier, elle doit être placée dans le bas.
- Si cette unité est montée dans un casier partiellement rempli, charger le casier de bas en haut en plaçant l'élément le plus lourd dans le bas.
- Si le casier est équipé de dispositifs stabilisateurs, installer les stabilisateurs avant de monter ou de réparer l'unité en casier.

Warnung Zur Vermeidung von Körperverletzung beim Anbringen oder Warten dieser Einheit in einem Gestell müssen Sie besondere Vorkehrungen treffen, um sicherzustellen, daß das System stabil bleibt. Die folgenden Richtlinien sollen zur Gewährleistung Ihrer Sicherheit dienen:

- Der Juniper Networks switch muß in einem Gestell installiert werden, das in der Gebäudestruktur verankert ist.
- Wenn diese Einheit die einzige im Gestell ist, sollte sie unten im Gestell angebracht werden.
- Bei Anbringung dieser Einheit in einem zum Teil gefüllten Gestell ist das Gestell von unten nach oben zu laden, wobei das schwerste Bauteil unten im Gestell anzubringen ist.
- Wird das Gestell mit Stabilisierungszubehör geliefert, sind zuerst die Stabilisatoren zu installieren, bevor Sie die Einheit im Gestell anbringen oder sie warten.

Avvertenza Per evitare infortuni fisici durante il montaggio o la manutenzione di questa unità in un supporto, occorre osservare speciali precauzioni per garantire che il sistema rimanga stabile. Le seguenti direttive vengono fornite per garantire la sicurezza personale:

- Il Juniper Networks switch deve essere installato in un telaio, il quale deve essere fissato alla struttura dell'edificio.
- Questa unità deve venire montata sul fondo del supporto, se si tratta dell'unica unità da montare nel supporto.

- Quando questa unità viene montata in un supporto parzialmente pieno, caricare il supporto dal basso all'alto, con il componente più pesante sistemato sul fondo del supporto.
- Se il supporto è dotato di dispositivi stabilizzanti, installare tali dispositivi prima di montare o di procedere alla manutenzione dell'unità nel supporto.

Advarsel Unngå fysiske skader under montering eller reparasjonsarbeid på denne enheten når den befinner seg i et kabinett. Vær nøye med at systemet er stabilt. Følgende retningslinjer er gitt for å verne om sikkerheten:

- Juniper Networks switch må installeres i et stativ som er forankret til bygningsstrukturen.
- Denne enheten bør monteres nederst i kabinettet hvis dette er den eneste enheten i kabinettet.
- Ved montering av denne enheten i et kabinett som er delvis fylt, skal kabinettet lastes fra bunnen og opp med den tyngste komponenten nederst i kabinettet.
- Hvis kabinettet er utstyrt med stabiliseringsutstyr, skal stabilisatorene installeres før montering eller utføring av reparasjonsarbeid på enheten i kabinettet.

Aviso Para se prevenir contra danos corporais ao montar ou reparar esta unidade numa estante, deverá tomar precauções especiais para se certificar de que o sistema possui um suporte estável. As seguintes directrizes ajudá-lo-ão a efectuar o seu trabalho com segurança:

- O Juniper Networks switch deverá ser instalado numa prateleira fixa à estrutura do edifício.
- Esta unidade deverá ser montada na parte inferior da estante, caso seja esta a única unidade a ser montada.
- Ao montar esta unidade numa estante parcialmente ocupada, coloque os itens mais pesados na parte inferior da estante, arrumando-os de baixo para cima.
- Se a estante possuir um dispositivo de estabilização, instale-o antes de montar ou reparar a unidade.

¡Atención! Para evitar lesiones durante el montaje de este equipo sobre un bastidor, oerriormente durante su mantenimiento, se debe poner mucho cuidado en que el sistema quede bien estable. Para garantizar su seguridad, proceda según las siguientes instrucciones:

- El Juniper Networks switch debe instalarse en un bastidor fijado a la estructura del edificio.
- Colocar el equipo en la parte inferior del bastidor, cuando sea la única unidad en el mismo.
- Cuando este equipo se vaya a instalar en un bastidor parcialmente ocupado, comenzar la instalación desde la parte inferior hacia la superior colocando el equipo más pesado en la parte inferior.
- Si el bastidor dispone de dispositivos estabilizadores, instalar éstos antes de montar o proceder al mantenimiento del equipo instalado en el bastidor.

Varning! För att undvika kroppsskada när du installerar eller utför underhållsarbete på denna enhet på en ställning måste du vidta särskilda försiktighetsåtgärder för att försäkra dig om att systemet står stadigt. Följande riktlinjer ges för att trygga din säkerhet:

- Juniper Networks switch måste installeras i en ställning som är förankrad i byggnadens struktur.
- Om denna enhet är den enda enheten på ställningen skall den installeras längst ned på ställningen.
- Om denna enhet installeras på en delvis fylld ställning skall ställningen fyllas nedifrån och upp, med de tyngsta enheterna längst ned på ställningen.
- Om ställningen är försedd med stabiliseringsdon skall dessa monteras fast innan enheten installeras eller underhålls på ställningen.

Grounded Equipment Warning



WARNING: This device must be properly grounded at all times. Follow the instructions in this guide to properly ground the device to earth.

Waarschuwing Dit apparaat moet altijd goed geaard zijn. Volg de instructies in deze gids om het apparaat goed te aarden.

Varoitus Laitteen on oltava pysyvästi maadoitettu. Maadoita laite asianmukaisesti noudattamalla tämän oppaan ohjeita.

Avertissement L'appareil doit être correctement mis à la terre à tout moment. Suivez les instructions de ce guide pour correctement mettre l'appareil à la terre.

Warnung Das Gerät muss immer ordnungsgemäß geerdet sein. Befolgen Sie die Anweisungen in dieser Anleitung, um das Gerät ordnungsgemäß zu erden.

Avvertenza Questo dispositivo deve sempre disporre di una connessione a massa. Seguire le istruzioni indicate in questa guida per connettere correttamente il dispositivo a massa.

Advarsel Denne enheten på jordes skikkelig hele tiden. Følg instruksjonene i denne veiledningen for å jorde enheten.

Aviso Este equipamento deverá estar ligado à terra. Siga las instrucciones en esta guía para conectar correctamente este dispositivo a tierra.

¡Atención! Este dispositivo debe estar correctamente conectado a tierra en todo momento. Siga las instrucciones en esta guía para conectar correctamente este dispositivo a tierra.

Varning! Den här enheten måste vara ordentligt jordad. Följ instruktionerna i den här guiden för att jorda enheten ordentligt.

Radiation from Open Port Apertures Warning



LASER WARNING: Because invisible radiation might be emitted from the aperture of the port when no fiber cable is connected, avoid exposure to radiation and do not stare into open apertures.

Waarschuwing Aangezien onzichtbare straling vanuit de opening van de poort kan komen als er geen fiberkabel aangesloten is, dient blootstelling aan straling en het kijken in open openingen vermeden te worden.

Varoitus Koska portin aukosta voi emittoitua näkymätöntä säteilyä, kun kuitukaapelia ei ole kytkettynä, vältä säteilylle altistumista äläkä katso avoimiin aukkoihin.

Avertissement Des radiations invisibles à l'il nu pouvant traverser l'ouverture du port lorsqu'aucun câble en fibre optique n'y est connecté, il est recommandé de ne pas regarder fixement l'intérieur de ces ouvertures.

Warnung Aus der Port-Öffnung können unsichtbare Strahlen emittieren, wenn kein Glasfaserkabel angeschlossen ist. Vermeiden Sie es, sich den Strahlungen auszusetzen, und starren Sie nicht in die Öffnungen!

Avvertenza Quando i cavi in fibra non sono inseriti, radiazioni invisibili possono essere emesse attraverso l'apertura della porta. Evitate di esporvi alle radiazioni e non guardate direttamente nelle aperture.

Advarsel Unngå utsettelse for stråling, og stirr ikke inn i åpninger som er åpne, fordi usynlig stråling kan emitteres fra portens åpning når det ikke er tilkoblet en fiberkabel.

Aviso Dada a possibilidade de emissão de radiação invisível através do orifício da via de acesso, quando esta não tiver nenhum cabo de fibra conectado, deverá evitar an EXposição à radiação e não deverá olhar fixamente para orifícios que se encontrarem a descoberto.

¡Atención! Debido a que la apertura del puerto puede emitir radiación invisible cuando no existe un cable de fibra conectado, evite mirar directamente a las aperturas para no exponerse a la radiación.

Warning! Osynlig strålning kan avges från en portöppning utan ansluten fiberkabel och du bör därför undvika att bli utsatt för strålning genom att inte stirra in i oskyddade öppningar.

Laser and LED Safety Guidelines and Warnings

IN THIS SECTION

- [General Laser Safety Guidelines | 499](#)
- [Class 1 Laser Product Warning | 499](#)
- [Class 1 LED Product Warning | 500](#)
- [Laser Beam Warning | 500](#)

Juniper Networks devices are equipped with laser transmitters, which are considered a Class 1 Laser Product by the U.S. Food and Drug Administration and are evaluated as a Class 1 Laser Product per IEC/EN 60825-1 requirements.

Observe the following guidelines and warnings:

General Laser Safety Guidelines

When working around ports that support optical transceivers, observe the following safety guidelines to prevent eye injury:

- Do not look into unterminated ports or at fibers that connect to unknown sources.
- Do not examine unterminated optical ports with optical instruments.
- Avoid direct exposure to the beam.



LASER WARNING: Unterminated optical connectors can emit invisible laser radiation. The lens in the human eye focuses all the laser power on the retina, so focusing the eye directly on a laser source—even a low-power laser—could permanently damage the eye.

Avertissement Les connecteurs à fibre optique sans terminaison peuvent émettre un rayonnement laser invisible. Le cristallin de l'œil humain faisant converger toute la puissance du laser sur la rétine, toute focalisation directe de l'œil sur une source laser, —même de faible puissance—, peut entraîner des lésions oculaires irréversibles.

Class 1 Laser Product Warning



LASER WARNING: Class 1 laser product.

Waarschuwing Klasse-1 laser produkt.

Varoitus Luokan 1 lasertuote.

Avertissement Produit laser de classe I.

Warnung Laserprodukt der Klasse 1.

Avvertenza Prodotto laser di Classe 1.

Advarsel Laserprodukt av klasse 1.

Aviso Produto laser de classe 1.

¡Atención! Producto láser Clase I.

Varning! Laserprodukt av klass 1.

Class 1 LED Product Warning



LASER WARNING: Class 1 LED product.

Waarschuwing Klasse 1 LED-product.

Varoitus Luokan 1 valodiodituote.

Avertissement Alarme de produit LED Class I.

Warnung Class 1 LED-Produktwarnung.

Avvertenza Avvertenza prodotto LED di Classe 1.

Advarsel LED-produkt i klasse 1.

Aviso Produto de classe 1 com LED.

¡Atención! Aviso sobre producto LED de Clase 1.

Varning! Lysdiodprodukt av klass 1.

Laser Beam Warning



LASER WARNING: Do not stare into the laser beam or view it directly with optical instruments.

Waarschuwing Niet in de straal staren of hem rechtstreeks bekijken met optische instrumenten.

Varoitus Älä katso säteeseen äläkä tarkastele sitä suoraan optisen laitteen avulla.

Avertissement Ne pas fixer le faisceau des yeux, ni l'observer directement à l'aide d'instruments optiques.

Warnung Nicht direkt in den Strahl blicken und ihn nicht direkt mit optischen Geräten prüfen.

Avvertenza Non fissare il raggio con gli occhi né usare strumenti ottici per osservarlo direttamente.

Advarsel Stirr eller se ikke direkte p strlen med optiske instrumenter.

Aviso Não olhe fixamente para o raio, nem olhe para ele directamente com instrumentos ópticos.

¡Atención! No mirar fijamente el haz ni observarlo directamente con instrumentos ópticos.

Warning! Rikta inte blicken in mot strålen och titta inte direkt på den genom optiska instrument.

Maintenance and Operational Safety Guidelines and Warnings

IN THIS SECTION

- [Battery Handling Warning | 502](#)
- [Jewelry Removal Warning | 503](#)
- [Lightning Activity Warning | 504](#)
- [Operating Temperature Warning | 505](#)
- [Product Disposal Warning | 506](#)

While performing the maintenance activities for devices, observe the following guidelines and warnings:

Battery Handling Warning



WARNING: Replacing a battery incorrectly might result in an explosion. Replace a battery only with the same or equivalent type recommended by the manufacturer. Dispose of used batteries according to the manufacturer's instructions.

Waarschuwing Er is ontploffingsgevaar als de batterij verkeerd vervangen wordt. Vervang de batterij slechts met hetzelfde of een equivalent type dat door de fabrikant aanbevolen is. Gebruikte batterijen dienen overeenkomstig fabrieksvoorschriften weggegooid te worden.

Varoitus Räjähdyksen vaara, jos akku on vaihdettu väärään akkuun. Käytä vaihtamiseen ainoastaan saman- tai vastaavantyyppistä akkua, joka on valmistajan suosittama. Hävitä käytetyt akut valmistajan ohjeiden mukaan.

Avertissement Danger d'explosion si la pile n'est pas remplacée correctement. Ne la remplacer que par une pile de type semblable ou équivalent, recommandée par le fabricant. Jeter les piles usagées conformément aux instructions du fabricant.

Warnung Bei Einsetzen einer falschen Batterie besteht Explosionsgefahr. Ersetzen Sie die Batterie nur durch den gleichen oder vom Hersteller empfohlenen Batterietyp. Entsorgen Sie die benutzten Batterien nach den Anweisungen des Herstellers.

Advarsel Det kan være fare for eksplosjon hvis batteriet skiftes på feil måte. Skift kun med samme eller tilsvarende type som er anbefalt av produsenten. Kasser brukte batterier i henhold til produsentens instruksjoner.

Avvertenza Pericolo di esplosione se la batteria non è installata correttamente. Sostituire solo con una di tipo uguale o equivalente, consigliata dal produttore. Eliminare le batterie usate secondo le istruzioni del produttore.

Aviso Existe perigo de explosão se a bateria for substituída incorrectamente. Substitua a bateria por uma bateria igual ou de um tipo equivalente recomendado pelo fabricante. Destrua as baterias usadas conforme as instruções do fabricante.

¡Atención! Existe peligro de explosión si la batería se reemplaza de manera incorrecta. Reemplazar la batería EXclusivamente con el mismo tipo o el equivalente recomendado por el fabricante. Desechar las baterías gastadas según las instrucciones del fabricante.

Varning! Explosionsfara vid felaktigt batteribyte. Ersätt endast batteriet med samma batterityp som rekommenderas av tillverkaren eller motsvarande. Följ tillverkarens anvisningar vid kassering av använda batterier.

Jewelry Removal Warning



WARNING: Before working on equipment that is connected to power lines, remove jewelry, including rings, necklaces, and watches. Metal objects heat up when connected to power and ground and can cause serious burns or can be welded to the terminals.

Waarschuwing Alvorens aan apparatuur te werken die met elektrische leidingen is verbonden, sieraden (inclusief ringen, kettingen en horloges) verwijderen. Metalen voorwerpen worden warm wanneer ze met stroom en aarde zijn verbonden, en kunnen ernstige brandwonden veroorzaken of het metalen voorwerp aan de aansluitklemmen lassen.

Varoitus Ennen kuin työskentelet voimavirtajohtoihin kytkettyjen laitteiden parissa, ota pois kaikki korut (sormukset, kaulakorut ja kellot mukaan lukien). Metalliesineet kuumenevat, kun ne ovat yhteydessä sähkövirran ja maan kanssa, ja ne voivat aiheuttaa vakavia palovammoja tai hitsata metalliesineet kiinni liitäntänapoihin.

Avertissement Avant d'accéder à cet équipement connecté aux lignes électriques, ôter tout bijou (anneaux, colliers et montres compris). Lorsqu'ils sont branchés à l'alimentation et reliés à la terre, les objets métalliques chauffent, ce qui peut provoquer des blessures graves ou souder l'objet métallique aux bornes.

Warnung Vor der Arbeit an Geräten, die an das Netz angeschlossen sind, jeglichen Schmuck (einschließlich Ringe, Ketten und Uhren) abnehmen. Metallgegenstände erhitzen sich, wenn sie an das Netz und die Erde angeschlossen werden, und können schwere Verbrennungen verursachen oder an die Anschlußklemmen angeschweißt werden.

Avvertenza Prima di intervenire su apparecchiature collegate alle linee di alimentazione, togliersi qualsiasi monile (inclusi anelli, collane, braccialetti ed orologi). Gli oggetti metallici si riscaldano quando sono collegati tra punti di alimentazione e massa: possono causare ustioni gravi oppure il metallo può saldarsi ai terminali.

Advarsel Fjern alle smykker (inkludert ringe, halskjeder og klokker) før du skal arbeide på utstyr som er koblet til kraftledninger. Metallgjenstander som er koblet til kraftledninger og jord blir svært varme og kan forårsake alvorlige brannskader eller smelte fast til polene.

Aviso Antes de trabalhar em equipamento que esteja ligado a linhas de corrente, retire todas as jóias que estiver a usar (incluindo anéis, fios e relógios). Os objectos metálicos aquecerão em contacto com a corrente e em contacto com a ligação à terra, podendo causar queimaduras graves ou ficarem soldados aos terminais.

¡Atención! Antes de operar sobre equipos conectados a líneas de alimentación, quitarse las joyas (incluidos anillos, collares y relojes). Los objetos de metal se calientan cuando se conectan a la alimentación y a tierra, lo que puede ocasionar quemaduras graves o que los objetos metálicos queden soldados a los bornes.

Varning! Tag av alla smycken (inklusive ringar, halsband och armbandsur) innan du arbetar på utrustning som är kopplad till kraftledningar. Metallobjekt hettas upp när de kopplas ihop med ström och jord och kan förorsaka allvarliga brännskador; metallobjekt kan också sammansvetsas med kontakterna.

Lightning Activity Warning



WARNING: Do not work on the system or connect or disconnect cables during periods of lightning activity.

Waarschuwing Tijdens onweer dat gepaard gaat met bliksem, dient u niet aan het systeem te werken of kabels aan te sluiten of te ontkoppelen.

Varoitus Älä työskentele järjestelmän parissa äläkä yhdistä tai irrota kaapeleita ukkosilmalla.

Avertissement Ne pas travailler sur le système ni brancher ou débrancher les câbles pendant un orage.

Warnung Arbeiten Sie nicht am System und schließen Sie keine Kabel an bzw. trennen Sie keine ab, wenn es gewittert.

Avvertenza Non lavorare sul sistema o collegare oppure scollegare i cavi durante un temporale con fulmini.

Advarsel Utfør aldri arbeid på systemet, eller koble kabler til eller fra systemet når det tordner eller lyner.

Aviso Não trabalhe no sistema ou ligue e desligue cabos durante períodos de mau tempo (trovoada).

¡Atención! No operar el sistema ni conectar o desconectar cables durante el transcurso de descargas eléctricas en la atmósfera.

Varning! Vid åska skall du aldrig utföra arbete på systemet eller ansluta eller koppla loss kablar.

Operating Temperature Warning



WARNING: To prevent the device from overheating, do not operate it in an area that exceeds the maximum recommended ambient temperature. To prevent airflow restriction, allow at least 6 in. (15.2 cm) of clearance around the ventilation openings.

Waarschuwing Om te voorkomen dat welke switch van de Juniper Networks router dan ook oververhit raakt, dient u deze niet te bedienen op een plaats waar de maximale aanbevolen omgevingstemperatuur van 40° C wordt overschreden. Om te voorkomen dat de luchtstroom wordt beperkt, dient er minstens 15,2 cm speling rond de ventilatie-openingen te zijn.

Varoitus Ettei Juniper Networks switch-sarjan reititin ylikuumentuisi, sitä ei saa käyttää tilassa, jonka lämpötila ylittää korkeimman suositellun ympäristölämpötilan 40° C. Ettei ilmanvaihto estyisi, tuuletusaukkojen ympärille on jätettävä ainakin 15,2 cm tilaa.

Avertissement Pour éviter toute surchauffe des routeurs de la gamme Juniper Networks switch, ne l'utilisez pas dans une zone où la température ambiante est supérieure à 40° C. Pour permettre un flot d'air constant, dégagez un espace d'au moins 15,2 cm autour des ouvertures de ventilations.

Warnung Um einen Router der switch vor Überhitzung zu schützen, darf dieser nicht in einer Gegend betrieben werden, in der die Umgebungstemperatur das empfohlene Maximum von 40° C überschreitet. Um Lüftungsverschluß zu verhindern, achten Sie darauf, daß mindestens 15,2 cm lichter Raum um die Lüftungsöffnungen herum frei bleibt.

Avvertenza Per evitare il surriscaldamento dei switch, non adoperateli in un locale che ecceda la temperatura ambientale massima di 40° C. Per evitare che la circolazione dell'aria sia impedita, lasciate uno spazio di almeno 15.2 cm di fronte alle aperture delle ventole.

Advarsel Unngå overoppheting av eventuelle rutere i Juniper Networks switch Disse skal ikke brukes på steder der den anbefalte maksimale omgivelsestemperaturen overstiger 40° C (104° F). Sørg for at klaringen rundt lufteåpningene er minst 15,2 cm (6 tommer) for å forhindre nedsatt luftsirkulasjon.

Aviso Para evitar o sobreaquecimento do encaminhador Juniper Networks switch, não utilize este equipamento numa área que exceda a temperatura máxima recomendada de 40° C. Para evitar a restrição à circulação de ar, deixe pelo menos um espaço de 15,2 cm à volta das aberturas de ventilação.

¡Atención! Para impedir que un encaminador de la serie Juniper Networks switch se recaliente, no lo haga funcionar en un área en la que se supere la temperatura ambiente máxima recomendada de 40° C. Para impedir la restricción de la entrada de aire, deje un espacio mínimo de 15,2 cm alrededor de las aperturas para ventilación.

Warning! Förhindra att en Juniper Networks switch överhettas genom att inte använda den i ett område där den maximalt rekommenderade omgivningstemperaturen på 40° C överskrids. Förhindra att luftcirkulationen inskränks genom att se till att det finns fritt utrymme på minst 15,2 cm omkring ventilationsöppningarna.

Product Disposal Warning



WARNING: Disposal of this device must be handled according to all national laws and regulations.

Waarschuwing Dit produkt dient volgens alle landelijke wetten en voorschriften te worden afgedankt.

Varoitus Tämän tuotteen lopullisesta hävittämisestä tulee huolehtia kaikkia valtakunnallisia lakeja ja säännöksiä noudattaen.

Avertissement La mise au rebut définitive de ce produit doit être effectuée conformément à toutes les lois et réglementations en vigueur.

Warnung Dieses Produkt muß den geltenden Gesetzen und Vorschriften entsprechend entsorgt werden.

Avvertenza L'eliminazione finale di questo prodotto deve essere eseguita osservando le normative italiane vigenti in materia

Advarsel Endelig disponering av dette produktet må skje i henhold til nasjonale lover og forskrifter.

Aviso A descartagem final deste produto deverá ser efectuada de acordo com os regulamentos e a legislação nacional.

¡Atención! El desecho final de este producto debe realizarse según todas las leyes y regulaciones nacionales

Warning! Slutlig kassering av denna produkt bör skötas i enlighet med landets alla lagar och föreskrifter.

General Electrical Safety Guidelines and Warnings



WARNING: Certain ports on the device are designed for use as intrabuilding (within-the-building) interfaces only (Type 2 or Type 4 ports as described in *GR-1089-CORE*) and require isolation from the exposed outside plant (OSP) cabling. To comply with NEBS (Network Equipment-Building System) requirements and protect against lightning surges and commercial power disturbances, the intrabuilding ports *must not* be metallicly connected to interfaces that connect to the OSP or its wiring. The intrabuilding ports on the device are suitable for connection to intrabuilding or unexposed wiring or cabling only. The addition of primary protectors is not sufficient protection for connecting these interfaces metallicly to OSP wiring.

Avertissement Certains ports de l'appareil sont destinés à un usage en intérieur uniquement (ports Type 2 ou Type 4 tels que décrits dans le document *GR-1089-CORE*) et doivent être isolés du câblage de l'installation extérieure exposée. Pour respecter les exigences NEBS et assurer une protection contre la foudre et les perturbations de tension secteur, les ports pour intérieur *ne doivent pas* être raccordés physiquement aux interfaces prévues pour la connexion à l'installation extérieure ou à son câblage. Les ports pour intérieur de l'appareil sont réservés au raccordement de câbles pour intérieur ou non exposés uniquement. L'ajout de protections ne constitue pas une précaution suffisante pour raccorder physiquement ces interfaces au câblage de l'installation extérieure.



CAUTION: Before removing or installing components of a device, connect an electrostatic discharge (ESD) grounding strap to an ESD point and wrap and fasten the other end of the strap around your bare wrist. Failure to use an ESD grounding strap could result in damage to the device.

Attention Avant de retirer ou d'installer des composants d'un appareil, raccordez un bracelet antistatique à un point de décharge électrostatique et fixez le bracelet à votre poignet nu. L'absence de port d'un bracelet antistatique pourrait provoquer des dégâts sur l'appareil.

- Install the device in compliance with the following local, national, and international electrical codes:
 - United States—National Fire Protection Association (NFPA 70), United States National Electrical Code.
 - Other countries—International Electromechanical Commission (IEC) 60364, Part 1 through Part 7.
 - Evaluated to the TN power system.

- Canada—Canadian Electrical Code, Part 1, CSA C22.1.
- Suitable for installation in Information Technology Rooms in accordance with Article 645 of the National Electrical Code and NFPA 75.

Peut être installé dans des salles de matériel de traitement de l'information conformément à l'article 645 du National Electrical Code et à la NFPA 75.

- Locate the emergency power-off switch for the room in which you are working so that if an electrical accident occurs, you can quickly turn off the power.
- Make sure that you clean grounding surface and give them a bright finish before making grounding connections.
- Do not work alone if potentially hazardous conditions exist anywhere in your workspace.
- Never assume that power is disconnected from a circuit. Always check the circuit before starting to work.
- Carefully look for possible hazards in your work area, such as moist floors, ungrounded power extension cords, and missing safety grounds.
- Operate the device within marked electrical ratings and product usage instructions.
- To ensure that the device and peripheral equipment function safely and correctly, use the cables and connectors specified for the attached peripheral equipment, and make certain they are in good condition.

You can remove and replace many device components without powering off or disconnecting power to the device, as detailed elsewhere in the hardware documentation for this device. Never install equipment that appears to be damaged.

Action to Take After an Electrical Accident

If an electrical accident results in an injury, take the following actions in this order:

1. Use caution. Be aware of potentially hazardous conditions that could cause further injury.
2. Disconnect power from the device.
3. If possible, send another person to get medical aid. Otherwise, assess the condition of the victim, and then call for help.

Prevention of Electrostatic Discharge Damage

Device components that are shipped in antistatic bags are sensitive to damage from static electricity. Some components can be impaired by voltages as low as 30 V. You can easily generate potentially damaging static voltages whenever you handle plastic or foam packing material or if you move components across plastic or carpets. Observe the following guidelines to minimize the potential for electrostatic discharge (ESD) damage, which can cause intermittent or complete component failures:

- Always use an ESD wrist strap when you are handling components that are subject to ESD damage, and make sure that it is in direct contact with your skin.

If a grounding strap is not available, hold the component in its antistatic bag (see [Figure 227 on page 510](#)) in one hand and touch the exposed, bare metal of the device with the other hand immediately before inserting the component into the device.



WARNING: For safety, periodically check the resistance value of the ESD grounding strap. The measurement must be in the range 1 through 10 Mohms.

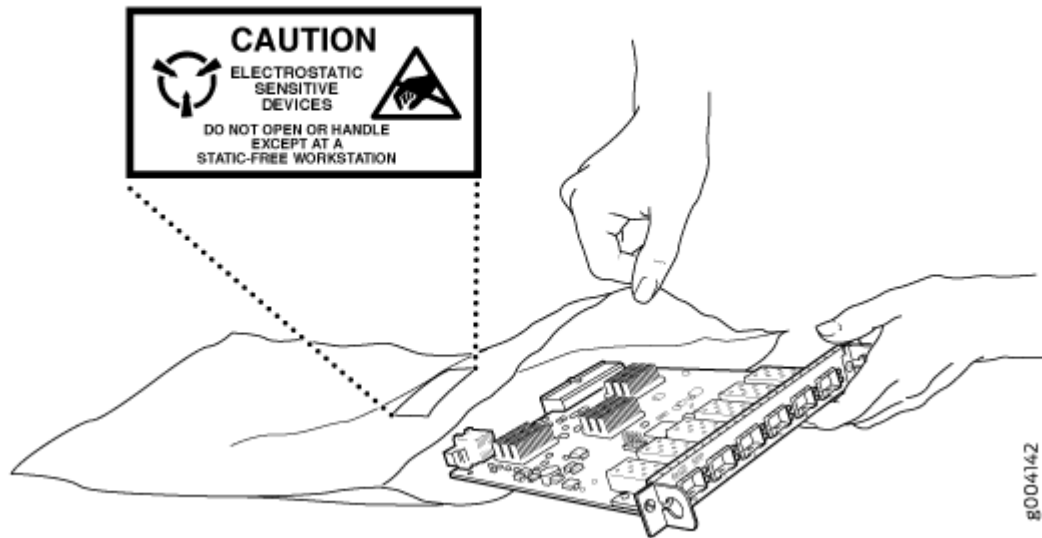
Avertissement Par mesure de sécurité, vérifiez régulièrement la résistance du bracelet antistatique. Cette valeur doit être comprise entre 1 et 10 mégohms (Mohms).

- When handling any component that is subject to ESD damage and that is removed from the device, make sure the equipment end of your ESD wrist strap is attached to the ESD point on the chassis.

If no grounding strap is available, touch the exposed, bare metal of the device to ground yourself before handling the component.

- Avoid contact between the component that is subject to ESD damage and your clothing. ESD voltages emitted from clothing can damage components.
- When removing or installing a component that is subject to ESD damage, always place it component-side up on an antistatic surface, in an antistatic card rack, or in an antistatic bag (see [Figure 227 on page 510](#)). If you are returning a component, place it in an antistatic bag before packing it.

Figure 227: Placing a Component into an Antistatic Bag



CAUTION: ANSI/TIA/EIA-568 cables such as Category 5e and Category 6 can get electrostatically charged. To dissipate this charge, always ground the cables to a suitable and safe earth ground before connecting them to the system.

Attention Les câbles ANSI/TIA/EIA-568, par exemple Cat 5e et Cat 6, peuvent emmagasiner des charges électrostatiques. Pour évacuer ces charges, reliez toujours les câbles à une prise de terre adaptée avant de les raccorder au système.

AC Power Electrical Safety Guidelines

The following electrical safety guidelines apply to AC-powered devices:

- Note the following warnings printed on the device:

“CAUTION: THIS UNIT HAS MORE THAN ONE POWER SUPPLY CORD. DISCONNECT ALL POWER SUPPLY CORDS BEFORE SERVICING TO AVOID ELECTRIC SHOCK.”

“ATTENTION: CET APPAREIL COMPORTE PLUS D'UN CORDON D'ALIMENTATION. AFIN DE PRÉVENIR LES CHOCS ÉLECTRIQUES, DÉBRANCHER TOUT CORDON D'ALIMENTATION AVANT DE FAIRE LE DÉPANNAGE.”

- AC-powered devices are shipped with a three-wire electrical cord with a grounding-type plug that fits only a grounding-type power outlet. Do not circumvent this safety feature. Equipment grounding must comply with local and national electrical codes.
- You must provide an external certified circuit breaker (2-pole circuit breaker or 4-pole circuit breaker based on your device) rated minimum 20 A in the building installation.
- The power cord serves as the main disconnecting device for the AC-powered device. The socket outlet must be near the AC-powered device and be easily accessible.
- For devices that have more than one power supply connection, you must ensure that all power connections are fully disconnected so that power to the device is completely removed to prevent electric shock. To disconnect power, unplug all power cords (one for each power supply).

Power Cable Warning (Japanese)

WARNING: The attached power cable is only for this product. Do not use the cable for another product.

注意

附属の電源コードセットはこの製品専用です。
他の電気機器には使用しないでください。

007783

AC Power Disconnection Warning



WARNING: Before working on the device or near power supplies, unplug all the power cords from an AC-powered device.

Waarschuwing Voordat u aan een frame of in de nabijheid van voedingen werkt, dient u bij wisselstroom toestellen de stekker van het netsnoer uit het stopcontact te halen.

Varoitus Kytke irti vaihtovirtalaitteiden virtajohto, ennen kuin teet mitään asennuspohjalle tai työskentelet virtalähteiden läheisyydessä.

Avertissement Avant de travailler sur un châssis ou à proximité d'une alimentation électrique, débrancher le cordon d'alimentation des unités en courant alternatif.

Warnung Bevor Sie an einem Chassis oder in der Nähe von Netzgeräten arbeiten, ziehen Sie bei Wechselstromeinheiten das Netzkabel ab bzw.

Avvertenza Prima di lavorare su un telaio o intorno ad alimentatori, scollegare il cavo di alimentazione sulle unità CA.

Advarsel Før det utføres arbeid på kabinettet eller det arbeides i nærheten av strømforsyningsenheter, skal strømledningen trekkes ut på vekselstrømsenheter.

Aviso Antes de trabalhar num chassis, ou antes de trabalhar perto de unidades de fornecimento de energia, desligue o cabo de alimentação nas unidades de corrente alternada.

¡Atención! Antes de manipular el chasis de un equipo o trabajar cerca de una fuente de alimentación, desenchufar el cable de alimentación en los equipos de corriente alterna (CA).

Varning! Innan du arbetar med ett chassi eller nära strömförsörjningsenheter skall du för växelströmsenheter dra ur nätsladden.

DC Power Electrical Safety Guidelines for the PTX10008 and PTX10016 Routers

This topic applies to hardware devices in the PTX10008 and PTX10016 routers.

- A DC-powered device is equipped with a DC terminal block that is rated for the power requirements of a maximally configured device.

NOTE: To supply sufficient power, terminate the DC input wiring on a facility DC source that is capable of supplying a minimum of 60 A at -48 VDC for the PTX10008 routers and PTX10016 routers.

Incorporate an easily accessible disconnect device into the facility wiring. Be sure to connect the ground wire or conduit to a solid office earth ground. A closed loop ring is recommended for terminating the ground conductor at the ground stud.

- Run two wires from the circuit breaker box to a source of 48 VDC.

- A DC-powered device that is equipped with a DC terminal block is intended for installation only in a restricted-access location. In the United States, a restricted-access area is one in accordance with Articles 110-16, 110-17, and 110-18 of the National Electrical Code ANSI/NFPA 70.

NOTE: Primary overcurrent protection is provided by the building circuit breaker. This breaker must protect against excess currents, short circuits, and earth grounding faults in accordance with NEC ANSI/NFPA 70.

- Ensure that the polarity of the DC input wiring is correct. Under certain conditions, connections with reversed polarity might trip the primary circuit breaker or damage the equipment.
- For personal safety, connect the green and yellow wire to safety (earth) ground at both the device and the supply side of the DC wiring.
- The marked input voltage of -48 VDC for a DC-powered device is the nominal voltage associated with the battery circuit, and any higher voltages are to be associated only with float voltages for the charging function.
- Because the device is a positive ground system, you must connect the positive lead to the terminal labeled **RTN**, the negative lead to the terminal labeled -48 VDC, and the earth ground to the device grounding points.

DC Power Copper Conductors Warning



WARNING: Use copper conductors only.

Waarschuwing Gebruik alleen koperen geleiders.

Varoitus Käytä vain kuparijohtimia.

Attention Utilisez uniquement des conducteurs en cuivre.

Warnung Verwenden Sie ausschließlich Kupferleiter.

Avvertenza Usate unicamente dei conduttori di rame.

Advarsel Bruk bare kobberledninger.

Aviso Utilize apenas fios condutores de cobre.

¡Atención! Emplee sólo conductores de cobre.

Warning! Använd endast ledare av koppar.

DC Power Disconnection Warning



WARNING: Before performing any of the DC power procedures, ensure that power is removed from the DC circuit. To ensure that all power is off, locate the circuit breaker on the panel board that services the DC circuit, switch the circuit breaker to the OFF position, and tape the device handle of the circuit breaker in the OFF position.

Waarschuwing Voordat u een van de onderstaande procedures uitvoert, dient u te controleren of de stroom naar het gelijkstroom circuit uitgeschakeld is. Om u ervan te verzekeren dat alle stroom UIT is geschakeld, kiest u op het schakelbord de stroomverbreker die het gelijkstroom circuit bedient, draait de stroomverbreker naar de UIT positie en plakt de schakelaarhendel van de stroomverbreker met plakband in de UIT positie vast.

Varoitus Varmista, että tasavirtapiirissä ei ole virtaa ennen seuraavien toimenpiteiden suorittamista. Varmistaaksesi, että virta on KATKAISTU täysin, paikanna tasavirrasta huolehtivassa kojetaulussa sijaitseva suojakytkin, käännä suojakytkin KATKAISTU-asentoon ja teippaa suojakytkimen varsi niin, että se pysyy KATKAISTU-asennossa.

Avertissement Avant de pratiquer l'une quelconque des procédures ci-dessous, vérifier que le circuit en courant continu n'est plus sous tension. Pour en être sûr, localiser le disjoncteur situé sur le panneau de service du circuit en courant continu, placer le disjoncteur en position fermée (OFF) et, à l'aide d'un ruban adhésif, bloquer la poignée du disjoncteur en position OFF.

Warnung Vor Ausführung der folgenden Vorgänge ist sicherzustellen, daß die Gleichstromschaltung keinen Strom erhält. Um sicherzustellen, daß sämtlicher Strom abgestellt ist, machen Sie auf der Schalttafel den Unterbrecher für die Gleichstromschaltung ausfindig, stellen Sie den Unterbrecher auf AUS, und kleben Sie den Schaltergriff des Unterbrechers mit Klebeband in der AUS-Stellung fest.

Avvertenza Prima di svolgere una qualsiasi delle procedure seguenti, verificare che il circuito CC non sia alimentato. Per verificare che tutta l'alimentazione sia scollegata (OFF), individuare l'interruttore automatico sul quadro strumenti che alimenta il circuito

CC, mettere l'interruttore in posizione OFF e fissarlo con nastro adesivo in tale posizione.

Advarsel Før noen av disse prosedyrene utføres, kontroller at strømmen er frakoblet likestrømkretsen. Sørg for at all strøm er slått AV. Dette gjøres ved å lokalisere strømbryteren på brytertavlen som betjener likestrømkretsen, slå strømbryteren AV og teipe bryterhåndtaket på strømbryteren i AV-stilling.

Aviso Antes de executar um dos seguintes procedimentos, certifique-se que desligou a fonte de alimentação de energia do circuito de corrente contínua. Para se assegurar que toda a corrente foi DESLIGADA, localize o disjuntor no painel que serve o circuito de corrente contínua e coloque-o na posição OFF (Desligado), segurando nessa posição a manivela do interruptor do disjuntor com fita isoladora.

¡Atención! Antes de proceder con los siguientes pasos, comprobar que la alimentación del circuito de corriente continua (CC) esté cortada (OFF). Para asegurarse de que toda la alimentación esté cortada (OFF), localizar el interruptor automático en el panel que alimenta al circuito de corriente continua, cambiar el interruptor automático a la posición de Apagado (OFF), y sujetar con cinta la palanca del interruptor automático en posición de Apagado (OFF).

Warning! Innan du utför någon av följande procedurer måste du kontrollera att strömförsörjningen till likströmskretsen är bruten. Kontrollera att all strömförsörjning är BRUTEN genom att slå AV det överspänningsskydd som skyddar likströmskretsen och tejsa fast överspänningsskyddets omkopplare i FRÅN-läget.

DC Power Grounding Requirements and Warning

An insulated grounding conductor that is identical in size to the grounded and ungrounded branch circuit supply conductors but is identifiable by green and yellow stripes is installed as part of the branch circuit that supplies the device. The grounding conductor is a separately derived system at the supply transformer or motor generator set.



WARNING: When you install the device, the ground connection must always be made first and disconnected last.

Waarschuwing Bij de installatie van het toestel moet de aardverbinding altijd het eerste worden gemaakt en het laatste worden losgemaakt.

Varoitus Laitetta asennettaessa on maahan yhdistäminen aina tehtävä ensiksi ja maadoituksen irti kytkeminen viimeiseksi.

Avertissement Lors de l'installation de l'appareil, la mise à la terre doit toujours être connectée en premier et déconnectée en dernier.

Warnung Der Erdanschluß muß bei der Installation der Einheit immer zuerst hergestellt und zuletzt abgetrennt werden.

Avvertenza In fase di installazione dell'unità, eseguire sempre per primo il collegamento a massa e disconnetterlo per ultimo.

Advarsel Når enheten installeres, må jordledningen alltid tilkobles først og frakobles sist.

Aviso Ao instalar a unidade, a ligação à terra deverá ser sempre a primeira a ser ligada, e a última a ser desligada.

¡Atención! Al instalar el equipo, conectar la tierra la primera y desconectarla la última.

Warning! Vid installation av enheten måste jordledningen alltid anslutas först och kopplas bort sist.

DC Power Wiring Sequence Warning



WARNING: Wire the DC power supply using the appropriate lugs. When connecting power, the proper wiring sequence is ground to ground, +RTN to +RTN, then -48 V to -48 V. When disconnecting power, the proper wiring sequence is -48 V to -48 V, +RTN to +RTN, then ground to ground. Note that the ground wire must always be connected first and disconnected last.

Waarschuwing De juiste bedradingsvolgorde verbonden is aarde naar aarde, +RTN naar +RTN, en -48 V naar -48 V. De juiste bedradingsvolgorde losgemaakt is en -48 naar -48 V, +RTN naar +RTN, aarde naar aarde.

Varoitus Oikea yhdistettävä kytkentäjäjärjestys on maajohto maajohtoon, +RTN varten +RTN, -48 V varten -48 V. Oikea irrotettava kytkentäjäjärjestys on -48 V varten -48 V, +RTN varten +RTN, maajohto maajohtoon.

Avertissement Câblez l'alimentation CC En utilisant les crochets appropriés à l'extrémité de câblage. En reliant la puissance, l'ordre approprié de câblage

est rectifié pour rectifier, +RTN à +RTN, puis -48 V à -48 V. En débranchant la puissance, l'ordre approprié de câblage est -48 V à -48 V, +RTN à +RTN, a alors rectifié pour rectifier. Notez que le fil de masse devrait toujours être relié d'abord et débranché pour la dernière fois. Notez que le fil de masse devrait toujours être relié d'abord et débranché pour la dernière fois.

Warnung Die Stromzufuhr ist nur mit geeigneten Ringösen an das DC Netzteil anzuschliessen. Die richtige Anschlusssequenz ist: Erdanschluss zu Erdanschluss, +RTN zu +RTN und dann -48V zu -48V. Die richtige Sequenz zum Abtrennen der Stromversorgung ist -48V zu -48V, +RTN zu +RTN und dann Erdanschluss zu Erdanschluss. Es ist zu beachten dass der Erdanschluss immer zuerst angeschlossen und als letztes abgetrennt wird.

Avvertenza Mostra la morsettiera dell alimentatore CC. Cablare l'alimentatore CC usando i connettori adatti all'estremità del cablaggio, come illustrato. La corretta sequenza di cablaggio è da massa a massa, da positivo a positivo (da linea ad L) e da negativo a negativo (da neutro a N). Tenere presente che il filo di massa deve sempre venire collegato per primo e scollegato per ultimo.

Advarsel Riktig tilkoples tilkoplingssekvens er jord til jord, +RTN til +RTN, -48 V til -48 V. Riktig frakoples tilkoplingssekvens er -48 V til -48 V, +RTN til +RTN, jord til jord.

Aviso Ate con alambre la fuente de potencia cc Usando los terminales apropiados en el extremo del cableado. Al conectar potencia, la secuencia apropiada del cableado se muele para moler, +RTN a +RTN, entonces -48 V a -48 V. Al desconectar potencia, la secuencia apropiada del cableado es -48 V a -48 V, +RTN a +RTN, entonces molió para moler. Observe que el alambre de tierra se debe conectar siempre primero y desconectar por último. Observe que el alambre de tierra se debe conectar siempre primero y desconectar por último.

¡Atención! Wire a fonte de alimentação de DC Usando os talões apropriados nan Extremidade da fiação. Ao conectar a potência, a seqüência apropriada da fiação é moída para moer, +RTN a +RTN, então -48 V a -48 V. Ao desconectar a potência, a seqüência apropriada da fiação é -48 V a -48 V, +RTN a +RTN, moeu então para moer. Anote que o fio à terra deve sempre ser conectado primeiramente e desconectado por último. Anote que o fio à terra deve sempre ser conectado primeiramente e desconectado por último.

Varning! Korrekt kopplingssekvens ar jord till jord, +RTN till +RTN, -48 V till -48 V. Korrekt kopplas kopplingssekvens ar -48 V till -48 V, +RTN till +RTN, jord till jord.

DC Power Wiring Terminations Warning



WARNING: When stranded wiring is required, use approved wiring terminations, such as closed-loop or spade-type with upturned lugs. These terminations must be the appropriate size for the wires and must clamp both the insulation and conductor.

Waarschuwing Wanneer geslagen bedrading vereist is, dient u bedrading te gebruiken die voorzien is van goedgekeurde aansluitpunten, zoals het gesloten-lus type of het grijperschop type waarbij de aansluitpunten omhoog wijzen. Deze aansluitpunten dienen de juiste maat voor de draden te hebben en dienen zowel de isolatie als de geleider vast te klemmen.

Varoitus Jos säikeellinen johdin on tarpeen, käytä hyväksyttyä johdinliitääntä, esimerkiksi suljettua silmukkaa tai kourumaista liitääntä, jossa on ylöspäin käännetyt kiinnityskorvat. Tällaisten liitääntöjen tulee olla kooltaan johtimiin sopivia ja niiden tulee puristaa yhteen sekä eristeen että johdinosan.

Avertissement Quand des fils torsadés sont nécessaires, utiliser des douilles terminales homologuées telles que celles à circuit fermé ou du type à plage ouverte avec cosses rebroussées. Ces douilles terminales doivent être de la taille qui convient aux fils et doivent être refermées sur la gaine isolante et sur le conducteur.

Warnung Wenn Litzenverdrahtung erforderlich ist, sind zugelassene Verdrahtungsabschlüsse, z.B. für einen geschlossenen Regelkreis oder gabelförmig, mit nach oben gerichteten Kabelschuhen zu verwenden. Diese Abschlüsse sollten die angemessene Größe für die Drähte haben und sowohl die Isolierung als auch den Leiter festklemmen.

Avvertenza Quando occorre usare trecce, usare connettori omologati, come quelli a occhiello o a forcilla con linguette rivolte verso l'alto. I connettori devono avere la misura adatta per il cablaggio e devono serrare sia l'isolante che il conduttore.

Advarsel Hvis det er nødvendig med flertrådede ledninger, brukes godkjente ledningsavslutninger, som for eksempel lukket sløyfe eller spadetype med oppoverbøyde kabelsko. Disse avslutningene skal ha riktig størrelse i forhold til ledningene, og skal klemme sammen både isolasjonen og ledere.

Aviso Quando forem requeridas montagens de instalação eléctrica de cabo torcido, use terminações de cabo aprovadas, tais como, terminações de cabo em circuito fechado e planas com terminais de orelha voltados para cima. Estas terminações de cabo deverão ser do tamanho apropriado para os respectivos cabos, e deverão prender simultaneamente o isolamento e o fio condutor.

¡Atención! Cuando se necesite hilo trenzado, utilizar terminales para cables homologados, tales como las de tipo "bucle cerrado" o "espada", con las lengüetas de conexión vueltas hacia arriba. Estos terminales deberán ser del tamaño apropiado para los cables que se utilicen, y tendrán que sujetar tanto el aislante como el conductor.

Warning! När flertrådiga ledningar krävs måste godkända ledningskontakter användas, t.ex. kabelsko av slutet eller öppen typ med uppåtvänd tapp. Storleken på dessa kontakter måste vara avpassad till ledningarna och måste kunna hålla både isoleringen och ledaren fastklämda.

Multiple Power Supplies Disconnection Warning



WARNING: The network device has more than one power supply connection. All connections must be removed completely to remove power from the unit completely.

Waarschuwing Deze eenheid heeft meer dan één stroomtoevoerverbinding; alle verbindingen moeten volledig worden verwijderd om de stroom van deze eenheid volledig te verwijderen.

Varoitus Tässä laitteessa on useampia virtalähdekytkentöjä. Kaikki kytkennät on irrotettava kokonaan, jotta virta poistettaisiin täysin laitteesta.

Avertissement Cette unité est équipée de plusieurs raccordements d'alimentation. Pour supprimer tout courant électrique de l'unité, tous les cordons d'alimentation doivent être débranchés.

Warnung Diese Einheit verfügt über mehr als einen Stromanschluß; um Strom gänzlich von der Einheit fernzuhalten, müssen alle Stromzufuhren abgetrennt sein.

Avvertenza Questa unità ha più di una connessione per alimentatore elettrico; tutte le connessioni devono essere completamente rimosse per togliere l'elettricità dall'unità.

Advarsel Denne enheten har mer enn én strømtilkobling. Alle tilkoblinger må kobles helt fra for å eliminere strøm fra enheten.

Aviso Este dispositivo possui mais do que uma conexão de fonte de alimentação de energia; para poder remover a fonte de alimentação de energia, deverão ser desconectadas todas as conexões existentes.

¡Atención! Esta unidad tiene más de una conexión de suministros de alimentación; para eliminar la alimentación por completo, deben desconectarse completamente todas las conexiones.

Varning! Denna enhet har mer än en strömförsörjningsanslutning; alla anslutningar måste vara helt avlägsnade innan strömtillförseln till enheten är fullständigt bruten.

TN Power Warning



WARNING: The device is designed to work with a TN power system.

Waarschuwing Het apparaat is ontworpen om te functioneren met TN energiesystemen.

Varoitus Koje on suunniteltu toimimaan TN-sähkövoimajärjestelmien yhteydessä.

Avertissement Ce dispositif a été conçu pour fonctionner avec des systèmes d'alimentation TN.

Warnung Das Gerät ist für die Verwendung mit TN-Stromsystemen ausgelegt.

Avvertenza Il dispositivo è stato progettato per l'uso con sistemi di alimentazione TN.

Advarsel Utstyret er utfomet til bruk med TN-strømsystemer.

Aviso O dispositivo foi criado para operar com sistemas de corrente TN.

¡Atención! El equipo está diseñado para trabajar con sistemas de alimentación tipo TN.

Varning! Enheten är konstruerad för användning tillsammans med elkraftssystem av TN-typ.

PTX10008 and PTX10016 Agency Approvals and Compliance Statements

IN THIS SECTION

- [Agency Approvals for the PTX10008 and PTX10016 Routers | 521](#)
- [Compliance Statements for EMC Requirements for the PTX10008 and PTX10016 Routers | 523](#)

Agency Approvals for the PTX10008 and PTX10016 Routers

IN THIS SECTION

- [Compliance Statement for Argentina | 523](#)

The PTX10008 and PTX10016 routers are tested against the following standards:

- Safety
 - UL 62368-1 Standard for Audio/video, information and communication technology equipment - Part 1: Safety requirements
 - CAN/CSA-C22.2 No. 60950-1 Information Technology Equipment – Safety
 - IEC 62368-1 Information Technology Equipment – Safety
 - IEC 60950-1 Information Technology Equipment – Safety CB Scheme report
 - IEC 60825-1 Laser safety
- EMC
 - FCC 47 CFR, Part 15 Class A (2012) USA radiated emissions – Class A
 - IC ICES-003 Issue 6, Jan 2016 Canada radiated emissions – Class A
 - EN 300 386 V1.6.1 Telecom network equipment – EMC requirements Class A

- EN 300 386 V2.1.1 Telecom network equipment – EMC requirements Class A
- EN 55032:2012 + EN55032:2012/AC:2013 Electromagnetic compatibility of multimedia equipment – Emission requirements Class A
- CISPR 32:2012 Electromagnetic compatibility of multimedia equipment – Emission Requirements Class A
- EN 55024:2010/AC:2011 European radiated emissions Class A
- CISPR 24 Information technology equipment - Immunity testing
- EN 55035:2017 – Electromagnetic compatibility of multimedia equipment – Immunity requirements
- CISPR 35:2016 – Electromagnetic compatibility of multimedia equipment – Immunity requirements
- IEC/EN 61000 Series – Electromagnetic compatibility
- AS/NZS CISPR 32:2015 Electromagnetic compatibility of multimedia equipment – Emission requirements Class A
- VCCI-CISPR 32:2016 Japanese radiated and conducted emissions Class A
- BSMI CNS 13438 – Taiwan radiated emissions Class A
- KN32 and KN35 – Korea radiated emission (at 10 Meter) Class A
- KN 61000 Series – Korea electromagnetic compatibility
- TEC/SD/DD/EMC-221/05/Oct-16 – Electromagnetic compatibility
- VCCI-V-3/2013.04 and V-4/2012.04 – Japanese radiated emissions Class A
- TCVN 7189 – Vietnam Electromagnetic compatibility for Multimedia
- TCVN 7317:2003 – Vietnam Electromagnetic compatibility for Multimedia
- Network Equipment Building System (NEBS)
 - EN 300 019-2-1 – Environmental engineering
 - EN 300 019-2-2 – Equipment engineering
 - EN 300 019-2-3 – Environmental engineering
 - EN 300 753 – Equipment engineering
 - GR-63-CORE – Requirements, physical protection

- GR-1089-CORE, Issue 7 – Acoustic noise

Compliance Statement for Argentina

EQUIPO DE USO IDÓNEO.

Compliance Statements for EMC Requirements for the PTX10008 and PTX10016 Routers

IN THIS SECTION

- [Canada | 523](#)
- [European Community | 524](#)
- [Israel | 524](#)
- [Japan | 524](#)
- [Korea | 525](#)
- [United States | 525](#)
- [Nonregulatory Environmental Standards | 525](#)

This topic describes the EMC requirements for the PTX10008 and PTX10016 routers for:

Canada

This Class A digital apparatus complies with Canadian ICES-003.

Cet appareil numérique de la classe A est conforme à la norme NMB-003 du Canada.

The Industry Canada label identifies certified equipment. This certification means that the equipment meets certain telecommunications network protective, operational, and safety requirements. Industry Canada does not guarantee the equipment will operate to the users' satisfaction.

Before installing this equipment, users should ensure that it is permissible to connect the equipment to the facilities of the local telecommunications company. The equipment must also be installed using an acceptable method of connection. In some cases, the inside wiring associated with a single line individual service may be extended by means of a certified connector assembly. The customer should be

aware that compliance with the above conditions may not prevent degradation of service in some situations.

Repairs to certified equipment should be made by an authorized Canadian maintenance facility designated by the supplier. Any repairs or alterations made by the user to this equipment, or equipment malfunctions, may give the telecommunications company cause to request the user to disconnect the equipment.



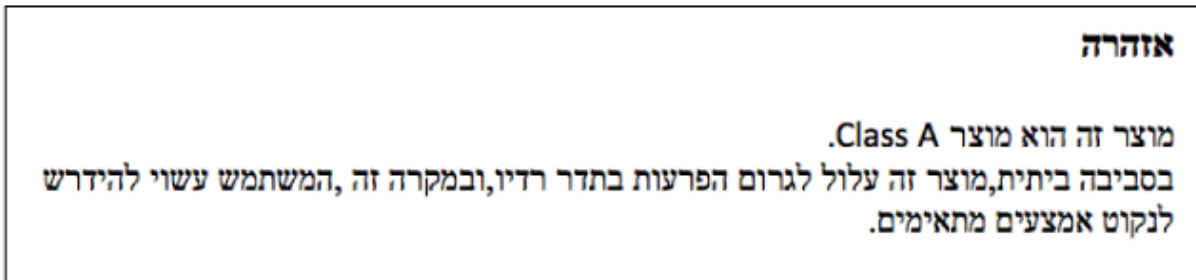
CAUTION: Users should not attempt to make electrical ground connections by themselves, but should contact the appropriate inspection authority or an electrician, as appropriate.

Users should ensure for their own protection that the electrical ground connections of the power utility, telephone lines, and internal metallic water pipe system, if present, are connected together. This precaution may be particularly important in rural areas.

European Community

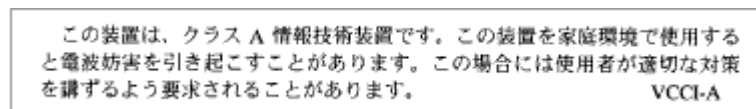
This is a Class A product. In a domestic environment this product may cause radio interference in which case the user may be required to take adequate measures.

Israel



Translation from Hebrew–Warning: This product is Class A. In residential environments, the product may cause radio interference, and in such a situation, the user may be required to take adequate measures.

Japan



The preceding translates as follows:

This is a Class A product. In a domestic environment this product may cause radio interference in which case the user may be required to take adequate measures.

VCCI-A

Korea

이 기기는 업무용(A급) 전자파적합기기로서 판매자 또는 사용자는 이 점을 주의하시기 바라며, 가정외의 지역에서 사용하는 것을 목적으로 합니다.

Korean Class A Warning

9040913

The preceding translates as follows:

This equipment is Industrial (Class A) electromagnetic wave suitability equipment and seller or user should take notice of it, and this equipment is to be used in the places except for home.

United States

The PTX10008 and PTX10016 devices have been tested and found to comply with the limits for a Class A digital device, pursuant to Part 15 of the FCC Rules. These limits are designed to provide reasonable protection against harmful interference when the equipment is operated in a commercial environment. This equipment generates, uses, and can radiate radio frequency energy and, if not installed and used in accordance with the instruction manual, may cause harmful interference to radio communications. Operation of this equipment in a residential area is likely to cause harmful interference in which case the user will be required to correct the interference at his own expense.

Nonregulatory Environmental Standards

These PTX Series product SKUs are designed to be Network Equipment Building System (NEBS) compliant:

- PTX10008
- PTX10016

For specific line card compliance, see [Table 128 on page 526](#).

Those device product SKUs are designed to meet the following NEBS compliance standards:

- SR-3580 NEBS Criteria Levels (Level 3 Compliance)
- GR-1089-CORE, Issue 7: EMC and Electrical Safety—Generic Criteria for Network Telecommunications Equipment
 - The equipment is suitable for installation in locations where the National Electrical Code (NEC) applies.
 - The battery return connection is to be treated as an Isolated DC return (DC-I), as defined in GR-1089-CORE.
- GR-63-CORE: NEBS, Physical Protection
 - The equipment is suitable for installation as part of the Common Bonding Network (CBN).
 - The equipment is suitable for installation in a central office (CO).

Table 128: Line Card Compliance

Line Card	Compliance
PTX10K-LC1101	NEBS compliant
PTX10K-LC1102	NEBS compliant
PTX10K-LC1104	Data center GR-3160 compliant
PTX10K-LC1105	NEBS compliant
PTX10K-LC1201-36CD	NEBS compliant
PTX10K-LC1202-36MR	Data center GR-3160 compliant when installed in a PTX10008 router
QFX10000-60S-6Q	NEBS compliant