

# QFX10008 Switch Hardware Guide

Published  
2024-05-27

Juniper Networks, Inc.  
1133 Innovation Way  
Sunnyvale, California 94089  
USA  
408-745-2000  
www.juniper.net

Juniper Networks, the Juniper Networks logo, Juniper, and Junos are registered trademarks of Juniper Networks, Inc. in the United States and other countries. All other trademarks, service marks, registered marks, or registered service marks are the property of their respective owners.

Juniper Networks assumes no responsibility for any inaccuracies in this document. Juniper Networks reserves the right to change, modify, transfer, or otherwise revise this publication without notice.

*QFX10008 Switch Hardware Guide*

Copyright © 2024 Juniper Networks, Inc. All rights reserved.

The information in this document is current as of the date on the title page.

## YEAR 2000 NOTICE

Juniper Networks hardware and software products are Year 2000 compliant. Junos OS has no known time-related limitations through the year 2038. However, the NTP application is known to have some difficulty in the year 2036.

## END USER LICENSE AGREEMENT

The Juniper Networks product that is the subject of this technical documentation consists of (or is intended for use with) Juniper Networks software. Use of such software is subject to the terms and conditions of the End User License Agreement ("EULA") posted at <https://support.juniper.net/support/eula/>. By downloading, installing or using such software, you agree to the terms and conditions of that EULA.

# Table of Contents

About This Guide | xi

1

## Overview

**QFX10008 System Overview | 2**

QFX10008 Hardware Overview | 2

QFX10008 Configurations and Upgrade Options | 14

QFX10000 Hardware and CLI Terminology Mapping | 19

QFX10000 Component Redundancy | 21

**QFX10008 Chassis | 23**

QFX10000 Field-Replaceable Units | 23

QFX10000 Status Panel | 25

QFX10000 EMI Front Panel | 27

QFX10000 Optional Equipment | 29

**QFX10008 Cooling System | 32**

QFX10008 Cooling System and Airflow | 32

QFX10000 Fan Tray LEDs and Fan Tray Controller LEDs | 37

**QFX10000 AC Power System | 44**

QFX10000-PWR-AC Power Supply | 45

QFX10000-PWR-AC Power Specifications | 48

JNP10K-PWR-AC2 Power Supply | 48

JNP10K-PWR-AC2 Power Specifications | 51

QFX10000 Power Cables Specifications | 52

QFX10000 AC Power Supply LEDs | 61

JNP10K-PWR-AC2 Power Supply LEDs | 63

**QFX10000 DC Power System | 65**

- QFX10000-PWR-DC Power Supply | 66
- QFX10000-PWR-DC Power Specifications | 69
- JNP10K-PWR-DC2 Power Supply | 70
- JNP10K-PWR-DC2 Power Specifications | 72
- QFX10000-PWR-DC Power Supply LEDs | 73
- JNP10K-PWR-DC2 Power Supply LEDs | 75

## **QFX10008 Switch Interface Board | 77**

- QFX10008 Switch Interface Board Description | 77
- QFX10008 Switch Interface Board LEDs | 79

## **QFX10000 Routing and Control Board | 81**

- QFX10000 Routing and Control Board Description | 81
- QFX10000 Routing and Control Board LEDs | 83

## **QFX10000 Line Cards | 88**

- QFX10000-30C Line Card | 88
- QFX10000-30C-M Line Card | 93
- QFX10000-36Q Line Card | 99
- QFX10000-60S-6Q Line Card | 107
- QFX10K-12C-DWDM Coherent Line Card | 114
- 1.2-Terabyte Per Second DWDM OTN Module Wavelengths | 120
- QFX10000 Line Card LEDs | 146
- Offline Button | 147

## **Site Planning, Preparation, and Specifications**

### **QFX10008 Site Preparation Checklist | 150**

### **QFX10008 Site Guidelines and Requirements | 151**

- QFX10000 Environmental Requirements and Specifications | 152
- General Site Guidelines | 153

Site Electrical Wiring Guidelines | 154

QFX10000 Rack Requirements | 155

QFX10000 Clearance Requirements for Airflow and Hardware Maintenance | 158

QFX10008 Chassis Physical Specifications | 159

### **QFX10008 Power Planning | 163**

Power Requirements for QFX10000 Components | 163

Calculating Power Requirements for a QFX10008 | 165

How to Calculate the Power Consumption of Your QFX10008 | 166

How to Calculate the Number of Power Supplies Required for Your QFX10008 | 168

QFX10008 and QFX100016 Grounding Cable and Lug Specifications | 170

### **QFX10000 Transceiver and Cable Specifications | 171**

QFX10000 Optical Transceiver and Cable Support | 171

Cable Specifications for QSFP+, QSFP28, and QSFP-DD Transceivers | 172

Understanding QFX Series Fiber-Optic Cable Signal Loss, Attenuation, and Dispersion | 174

Calculating Power Budget and Power Margin for Fiber-Optic Cables | 176

How to Calculate Power Budget for Fiber-Optic Cables | 176

How to Calculate Power Margin for Fiber-Optic Cables | 177

### **QFX10000 Console and Management Cable Specifications and Pinouts | 179**

QFX10000 Cable Specifications for Console and Management Connections | 179

RJ-45 to DB-9 Serial Port Adapter Pinout Information | 180

RJ-45 Management Port Connector Pinout Information | 181

Console Port Connector Pinout Information | 182

USB Port Specifications for the QFX Series | 183

## **3**

### **Initial Installation and Configuration**

**QFX10008 Installation Overview | 186**

**Unpacking the QFX10008 | 187**

Unpacking the Chassis | 187

Unpacking QFX10000 Line Cards, Routing and Control Boards, and Switch Interface Boards | 189

Comparing the QFX10000 Order to the Packing List | 191

Register Products—Mandatory to Validate SLAs | 197

## **Installing the Mounting Hardware for a QFX10000 | 197**

### **Installing the QFX10008 into a Rack | 200**

Mounting a QFX10008 in a 4-Post Rack Using a Mechanical Lift | 200

Manually Mounting a QFX10008 in a 4-Post Rack | 203

### **Installing the Front Panel on a QFX10000 | 207**

### **Connecting the QFX10008 or QFX10016 to Power | 213**

Connect the QFX10008 or QFX10016 to Earth Ground | 213

Connect AC Power to a QFX Modular Chassis | 217

Connect DC Power to a QFX10008 or QFX10016 | 217

### **Connecting the QFX10000 to External Devices | 218**

Connect a Device to a Network for Out-of-Band Management | 219

Connect a Device to a Management Console Using an RJ-45 Connector | 219

### **Performing an Initial Configuration of a QFX10000 | 221**

## **4**

## **Maintaining Components**

### **Handling and Storing QFX10000 Line Cards, RCBs, and SIBs | 226**

Holding Line Cards and RCBs | 226

Holding SIBs | 227

Storing Line Cards, RCBs, and SIBs | 229

### **Maintaining QFX10000 Routing and Control Boards | 230**

Removing a QFX10000 Routing and Control Board | 230

Installing a QFX10000 Routing and Control Board | 232

### **Maintaining QFX10008 Cooling System | 235**

Removing a QFX10008 Fan Tray | 235

Installing a QFX10008 Fan Tray | 237

Removing a QFX10008 Fan Tray Controller | 239

Installing a QFX10008 Fan Tray Controller | 241

### **Maintaining QFX10000 Power System | 243**

How to Remove a QFX10000-PWR-AC Power Supply | 244

How to Install a QFX10000-PWR-AC Power Supply | 248

How to Remove a JNP10K-PWR-AC2 Power Supply | 256

How to Install a JNP10K-PWR-AC2 Power Supply | 260

How to Remove a QFX10000-PWR-DC Power Supply | 267

How to Install a QFX10000-PWR-DC Power Supply | 271

How to Remove a JNP10K-PWR-DC2 Power Supply | 283

How to Install a JNP10K-PWR-DC2 Power Supply | 287

### **Maintaining QFX10000 Switch Interface Boards | 298**

Removing a QFX10000 Switch Interface Board | 298

Installing a QFX10000 Switch Interface Board | 303

### **Maintaining QFX10000 Line Cards | 309**

Removing a QFX10000 Line Card | 309

Installing a QFX10000 Line Card | 313

Installing the QFX10000 Cable Management System | 316

### **Maintaining QFX10000 Solid State Drives | 319**

Removing the Optional SATA Solid State Drive in a QFX10000 | 319

Installing the Optional SATA Solid State Drive in a QFX10000 | 321

### **Maintaining Transceivers and Fiber-Optic Cables on QFX10000 | 323**

Removing a Transceiver | 323

Install a Transceiver | 325

Disconnect a Fiber-Optic Cable | 329

Connect a Fiber-Optic Cable | 329

How to Handle Fiber-Optic Cables | 330

## Removing the QFX10008 | 331

Powering Off a QFX10000 | 332

Removing a QFX10008 From a 4-Post Rack Using a Mechanical Lift | 334

Manually Removing a QFX10008 from a 4-Post Rack | 336

5

## Troubleshooting

### Troubleshooting QFX10000 Modular Chassis | 341

QFX10000 Troubleshooting Resources Overview | 341

QFX Series Alarm Messages Overview | 342

Chassis Alarm Messages on QFX10008 and QFX10016 Modular Chassis Switches | 342

6

## Contacting Customer Support and Returning the Chassis or Components

### Contact Customer Support to Obtain a Return Material Authorization | 348

### Returning the QFX10000 Chassis or Component | 349

How to Return a Hardware Component to Juniper Networks, Inc. | 349

Locating the Serial Number on a QFX10000 Switch or Component | 350

Listing the Chassis and Component Details Using the CLI | 351

Locating the Chassis Serial Number ID Label on a QFX10008 or QFX10016 | 352

Locating the Serial Number ID Labels on QFX10000 Power Supplies | 354

Locating the Serial Number ID Labels on QFX10000 Fan Trays and Fan Tray Controllers | 357

Locating the Serial Number ID Labels on QFX10000 Routing Control Boards | 358

Locating the Serial Number ID Labels on a QFX10000 Line Card | 358

Locating the Serial Number ID Labels on a QFX10000 Switch Interface Board (SIB) | 359

Locating the Serial Number ID Label on a QFX10000 SATA SSD | 359

Packing a QFX10000 or Component for Shipping | 360

Packing a QFX10000 Switch Chassis for Shipping | 360

Packing QFX10000 Switch Components for Shipping | 365

7

## Safety and Compliance Information

### General Safety Guidelines and Warnings | 369



Definitions of Safety Warning Levels	370
Qualified Personnel Warning	372
Warning Statement for Norway and Sweden	372
Fire Safety Requirements	373
Installation Instructions Warning	374
Chassis and Component Lifting Guidelines	375
Restricted Access Warning	375
Ramp Warning	377
Rack-Mounting and Cabinet-Mounting Warnings	377
Grounded Equipment Warning	381
Radiation from Open Port Apertures Warning	382
Laser and LED Safety Guidelines and Warnings for the QFX Series	383
Maintenance and Operational Safety Guidelines and Warnings	386
General Electrical Safety Guidelines and Warnings	392
Action to Take After an Electrical Accident	394
Prevention of Electrostatic Discharge Damage	394
AC Power Electrical Safety Guidelines	396
AC Power Disconnection Warning	397
DC Power Electrical Safety Guidelines	398
DC Power Disconnection Warning	399
DC Power Grounding Requirements and Warning	400
DC Power Wiring Terminations Warning	401
Multiple Power Supplies Disconnection Warning	403
TN Power Warning	403
Agency Approvals for the QFX Series	404

**Compliance Statements for EMC Requirements for the QFX Series | 406**

**QFX Series Compliance Statements for NEBS | 410**

**Compliance Statements for Environmental Requirements | 411**

# About This Guide

Use this guide to plan, install, perform initial software configuration, perform routine maintenance, and to troubleshoot QFX10008 modular switches.

After completing the installation and basic configuration procedures covered in this guide, refer to the Junos OS documentation for further software configuration.

# 1

CHAPTER

## Overview

---

QFX10008 System Overview | 2

QFX10008 Chassis | 23

QFX10008 Cooling System | 32

QFX10000 AC Power System | 44

QFX10000 DC Power System | 65

QFX10008 Switch Interface Board | 77

QFX10000 Routing and Control Board | 81

QFX10000 Line Cards | 88

---

# QFX10008 System Overview

## IN THIS SECTION

- [QFX10008 Hardware Overview | 2](#)
- [QFX10008 Configurations and Upgrade Options | 14](#)
- [QFX10000 Hardware and CLI Terminology Mapping | 19](#)
- [QFX10000 Component Redundancy | 21](#)

## QFX10008 Hardware Overview

### IN THIS SECTION

- [Benefits of QFX10000 Modular Chassis Switches | 3](#)
- [Chassis Description | 3](#)
- [Routing and Control Board | 6](#)
- [Line Cards | 7](#)
- [Switch Fabric | 8](#)
- [Cooling System | 9](#)
- [Power Supplies | 10](#)
- [Software | 13](#)

The Juniper Networks® QFX10008 modular switch builds a strong underlay foundation for flexible, high-performance, standards-based fabrics and routing that improve network reliability and agility. This high-performance, 13 rack unit (13 U) modular chassis can provide 48 Tbps of throughput and 16 Bpps of forwarding capacity. The QFX10008 has eight slots for line cards that can support a maximum of 1152 10-Gigabit Ethernet ports, 288 40-Gigabit Ethernet ports, or 240 100-Gigabit Ethernet ports.

The QFX10008 can be deployed in various network designs and fabrics including:

- Layer 3 fabrics

- Junos Fusion
- Juniper Networks MC-LAG for Layer 2 and 3 networks

The QFX10008 is available in both base and redundant configurations for both AC and DC operation. All systems feature front to back airflow. This airflow is also known as airflow out (AFO).

This topic covers:

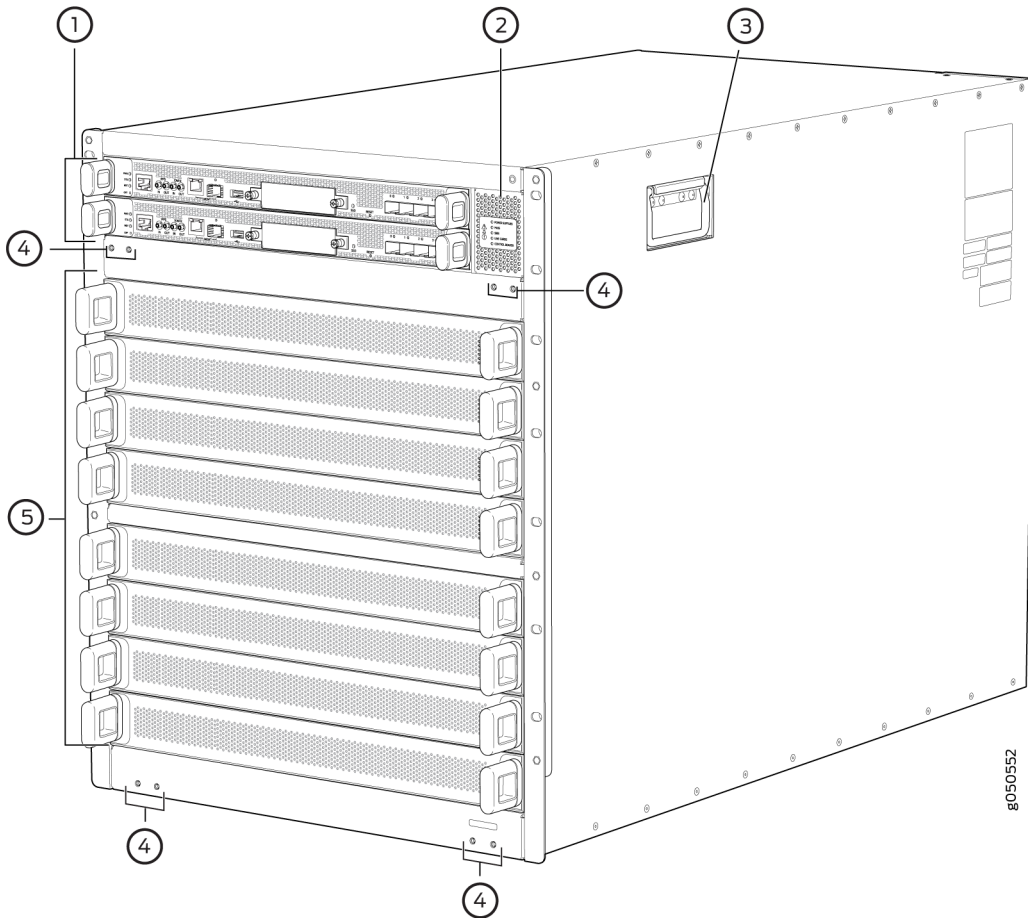
## Benefits of QFX10000 Modular Chassis Switches

<b>System throughput</b>	The Juniper Networks® QFX10008 line of modular switches delivers up to 96 Tbps of system throughput to meet the rapid and ongoing traffic growth in data center, campus, and routing environments. Industry-leading scale and density on the QFX10008 modular switches redefine per-slot economics, enabling you to do more with less while simplifying network design and reducing operating expenditures.
<b>Logical scale</b>	The QFX10008 modular switches deliver the highest Layer 2 / Layer 3 scale with up to 1 million MAC addresses, 2 million host routes, and 2 million FIB. The system also supports deep buffers with up to 100ms packet buffering per port. Virtual output Queue (VoQ) based architecture prevents head-of-line blocking.
<b>Network architectures</b>	The QFX10008 line can be deployed in a number of different network designs, including IP fabrics, EVPN-VXLAN overlays for Layer 2 and Layer 3 networks, along with support for DC edge and DCI use cases, giving customers complete architectural flexibility. Additionally, the open architecture ensures that customers can innovate on top of Juniper Networks Junos® operating system to accelerate the pace of innovation.

## Chassis Description

The QFX10008 is 13 U tall. Up to 3 QFX10008 chassis can fit in a standard 42 U rack with adequate cooling and power. All key QFX10008 components are field-replaceable units (FRUs). [Figure 1 on page 4](#) illustrates the key components visible from the front of the chassis, [Figure 2 on page 5](#) illustrates the components that are visible from the rear of the chassis, and [Figure 3 on page 6](#) illustrates the components that are internal to the chassis.

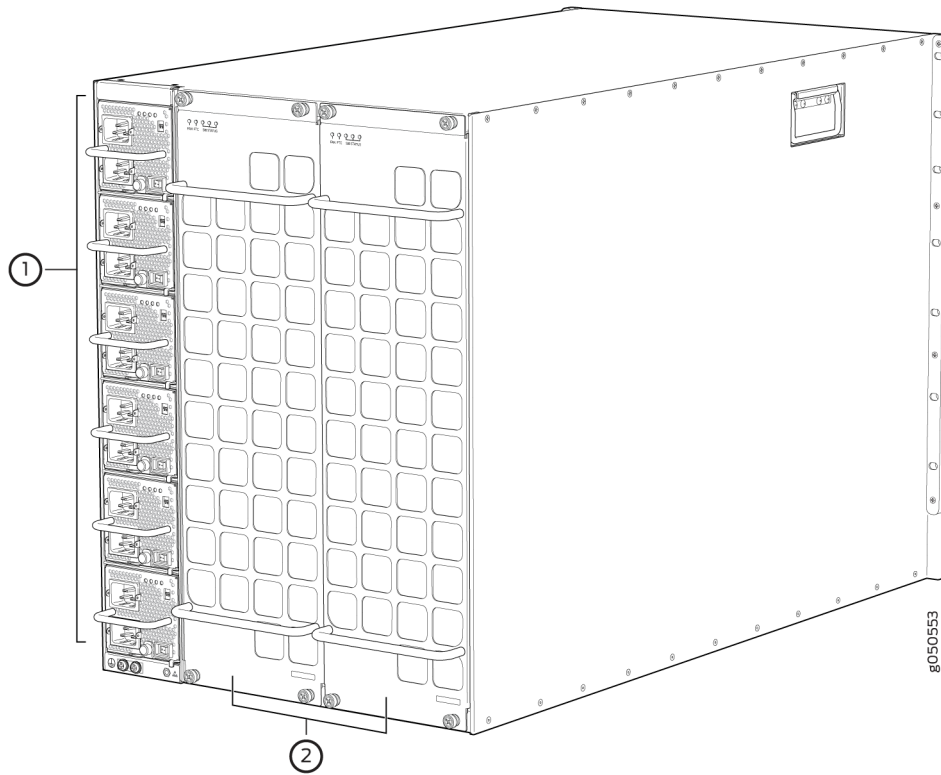
Figure 1: QFX10008 Chassis Front



1– RCBs slots 0 and 1 (numbered top to bottom)	4– Installation holes for the front panel
2– Status LED panel	5– Line card slots 0-7 (numbered top to bottom)
3– Handles	

Some chassis ship with an enhanced power bus to support the power needs of higher wattage line cards. Chassis with the enhanced power bus have a modified Status Panel (see "[QFX10000 Status Panel](#)" on page 25).

Figure 2: QFX10008 Chassis Rear



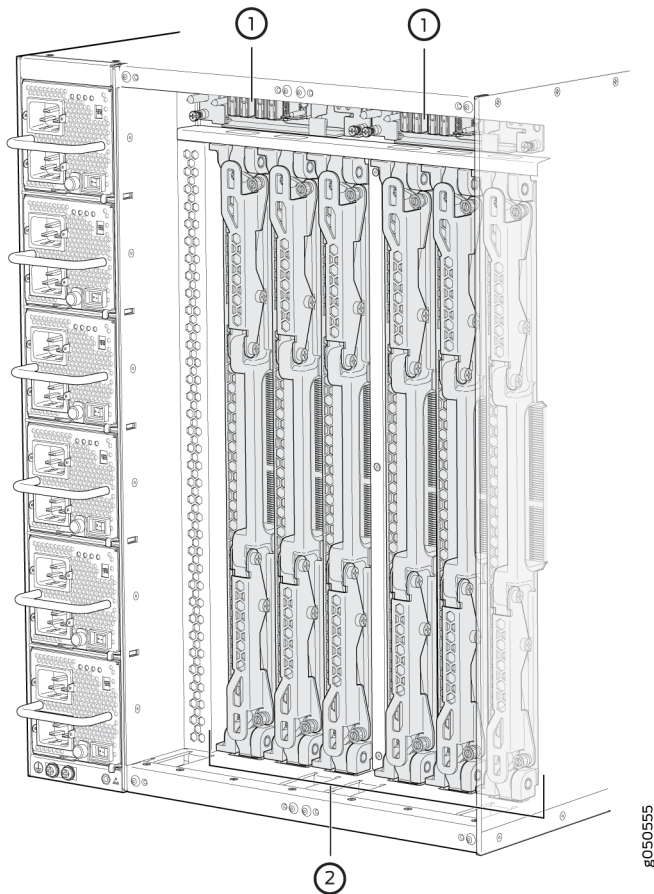
1– AC or DC power supplies slots 0-7  
(numbered top to bottom)

2– Fan trays with redundant fans

Figure 3 on page 6 illustrates the components that are internal to the chassis.



Figure 3: QFX10008 Chassis Internal Components



1– Fan tray controllers slots 0 and 1 (numbered left to right)

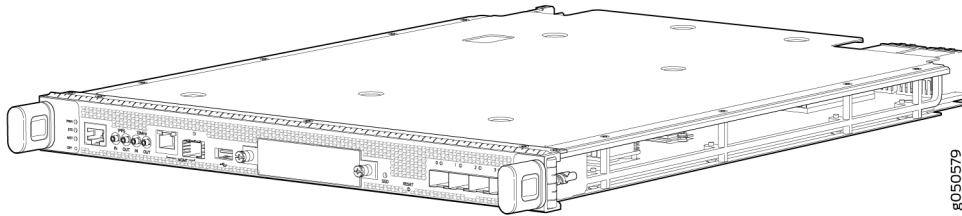
2– Switch interface boards (SIBs) slots 0-5 (numbered left to right)

See ["QFX10008 Chassis Physical Specifications"](#) on page 159 and ["QFX10000 Field-Replaceable Units"](#) on page 23.

## Routing and Control Board

The Routing and Control Board (RCB) contains a routing engine and Control Board that is responsible for system management and system control in the QFX10008 switch. See [Figure 4 on page 7](#). RCBs are field replaceable and installed in the front of the chassis in the slots labeled **CB0** and **CB1**. The base configuration has a single RCB; the fully-redundant configuration has two RCBs. The RCB also contains Precision Time Protocol (PTP) ports and four Media Access Control Security (MACsec) capable ports. See ["QFX10000 Routing and Control Board Description"](#) on page 81.

**Figure 4: QFX10000 Routing and Control Board (QFX10000-RE)**



## Line Cards

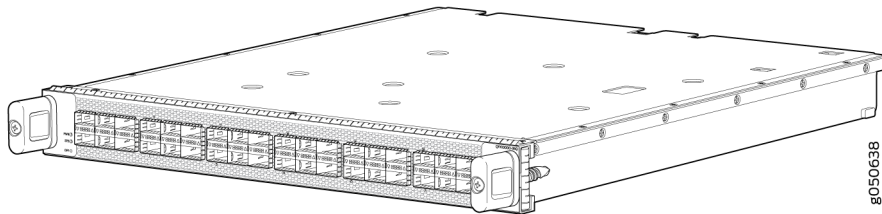
The QFX10008 features eight horizontal line card slots and supports line rate for each line card. The line cards combine a Packet Forwarding Engine (PFE) and Ethernet interfaces enclosed in a single assembly. The QFX10008 line-card architecture is based on number of identical, independent PFE slices each with 500 Gbps full-duplex throughput. Line cards are FRUs that can be installed in the line-card slots labeled **0** through **7** (top to bottom) on the front of the switch chassis. All line cards are hot-removable and hot-insertable.

The QFX10008 supports the following line cards:

- QFX10000-36Q—provides 36 ports of 40-gigabit QSFP+. Twelve ports are designed to be 100-Gigabit capable using QSFP28. Each of the 40-Gigabit QSFP+ can be configured as either a native 40-Gigabit port or four 10-Gigabit ports using a breakout cable. With breakout cables, the line card supports a maximum of 144 logical 10-Gigabit Ethernet ports.
- QFX10000-30C—provides 30 ports of either 100-gigabit or 40-gigabit QSFP28. The ports autodetect the type of transceiver installed and set the configuration to the appropriate speed. Each of the 40-gigabit ports can be configured as either a native 40-gigabit port or four 10-gigabit ports using a breakout cable. With breakout cables, the line card supports a maximum of 96 logical 10-Gigabit Ethernet ports.
- QFX10000-30C-M—provides 30 ports of either 100-gigabit or 40-gigabit QSFP28 that support MACsec security features.
- QFX10000-60S-6Q—provides 60 SFP+ ports that can be configured for either 1-gigabit or 10-gigabit speeds. The card also provides six flexible configuration ports for 100-gigabit and 40-gigabit speeds. Of the six flexible configuration ports, two ports have QSFP28 sockets that support either 100-gigabit or 40-gigabit speeds. The remaining four ports have QSFP+ sockets that can be configured as either a native 40-gigabit port or four 10-gigabit ports using a breakout cable. With breakout cables, the line card supports a maximum of 84 logical 10-Gigabit Ethernet ports.
- QFX10K-12C-DWDM—provides 6 coherent dense wavelength-division multiplexing (DWDM) ports with built-in optics. The card supports MACsec security features and provides a flexible rate modulation at 100 Gbps, 150 Gbps, and 200 Gbps speeds.

See [Figure 5 on page 8](#) for an example of a QFX10008 line card.

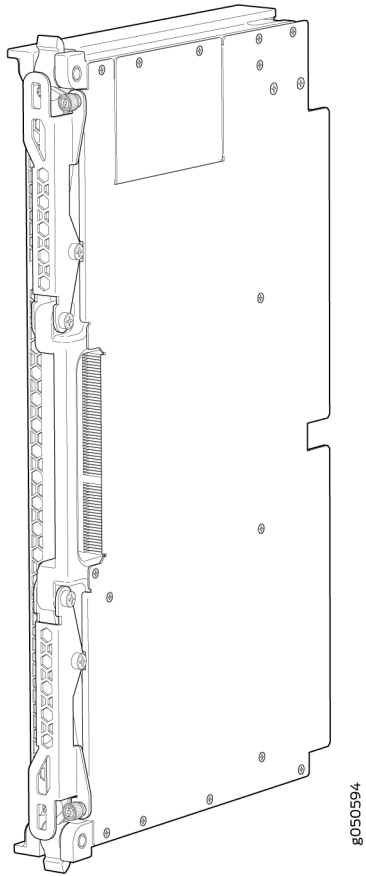
**Figure 5: QFX10000-36Q Line Card**



## Switch Fabric

Five Switch Interface Boards (SIBs) provide the necessary switching functionality to a base configuration QFX10008. A sixth SIB is available in the redundant configuration to provide  $n+1$  redundancy. SIBs are installed between the line cards and the fan trays inside of the chassis (see [Figure 6 on page 9](#)). Each QFX10008 SIB has eight connectors that match to a line-card slot, eliminating the need for a backplane. When all six SIBs are installed, the QFX10008 has a net switching capacity of 42 Tbps. See "[QFX10008 Switch Interface Board](#)" on page 77.

Figure 6: SIB (QFX10008-SF)



## Cooling System

The cooling system in a QFX10008 consists of two hot-removable and hot-insertable field-replaceable fan trays (see [Figure 7 on page 10](#)) and two fan tray controllers (see [Figure 8 on page 10](#)). The fan trays install vertically on the rear of the chassis and provides front-to-back chassis cooling. See "[QFX10008 Cooling System](#)" on page 32.

Figure 7: Fan Tray ( QFX10008-FAN)

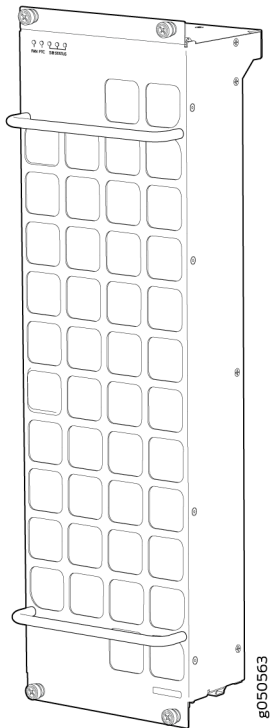
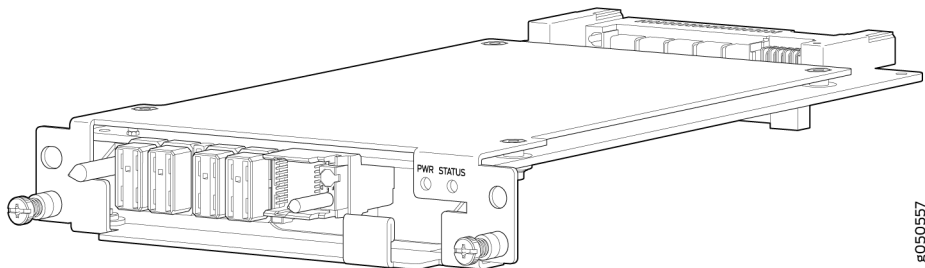


Figure 8: Fan Tray Controller (QFX10008-FAN-CTRL)



## Power Supplies

The QFX10008 switches support AC, DC, high voltage alternating current (HVAC) and high voltage direct current (HVDC) by offering the following power supplies:

- QFX10000-PWR-AC
- JNP10K-PWR-AC2

- QFX10000-PWR-DC
- JNP10K-PWR-DC2

All of the power supplies are fully redundant, load-sharing, and hot-removable and hot-insertable field-replaceable units (FRUs). Each QFX10008 base configuration has three QFX10000-PWR-AC or QFX10000-PWR-DC power supplies; redundant configurations hold the maximum of six QFX10000-PWR-AC or QFX10000-PWR-DC power supplies. There are also high-voltage alternating current (HVAC), DC and high-voltage direct current (HVDC) base and redundant configurations. See "[QFX10008 Configurations and Upgrade Options](#)" on page 14. Each power supply has an internal fan for cooling. You can install the power supplies in any slot. See [Table 1 on page 11](#) and [Figure 9 on page 12](#) through [Figure 12 on page 13](#). See [QFX10000 Status Panel. Table 1 on page 11](#) provides the specifications for these different power supplies.

**Table 1: Power Supply Overview**

	QFX10000-PWR-AC	JNP10K-PWR-AC2	QFX10000-PWR-DC	JNP10K-PWR-DC2
Maximum output power	2700 W	5000 W, single feed or 5500 W, dual feed when set for high power (30-A); 3000 W when set for low power (20-A)	2500 W	5500 W when set for high power (80-A) or 4400 W when set for low power (60-A)
Inputs	2 AC only ( <b>INP1</b> , <b>INP2</b> )	2 AC, HVAC, or HVDC ( <b>INP1</b> , <b>INP2</b> )	2 DC only ( <b>INPUT 1</b> , <b>INPUT 2</b> )	4 DC only ( <b>INPUT 1</b> , <b>INPUT 2</b> )
Minimum Junos OS release	15.1X53	19.2R1	15.1X53	19.2R1



**CAUTION:** Do not mix power supply models in the same chassis in a running environment. DC and HVDC power supplies can coexist in the same chassis when you hot swap of DC for an HVDC model. The system provides  $2n$  source redundancy and  $n + 1$  power supply redundancy. If one power source fails, the power supply switches to the alternate source.

Figure 9: QFX10000-PWR-AC Power Supply

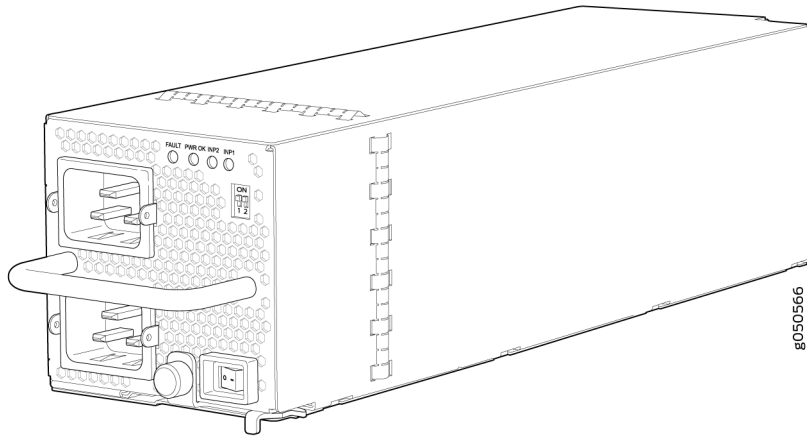
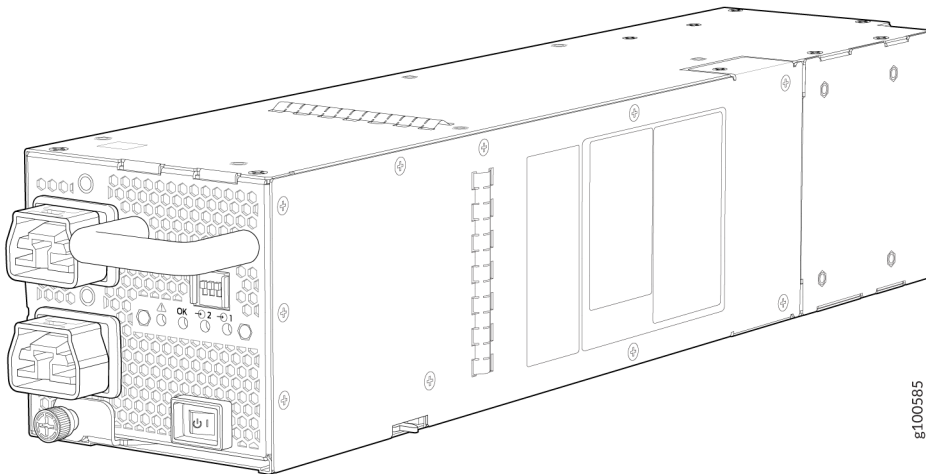
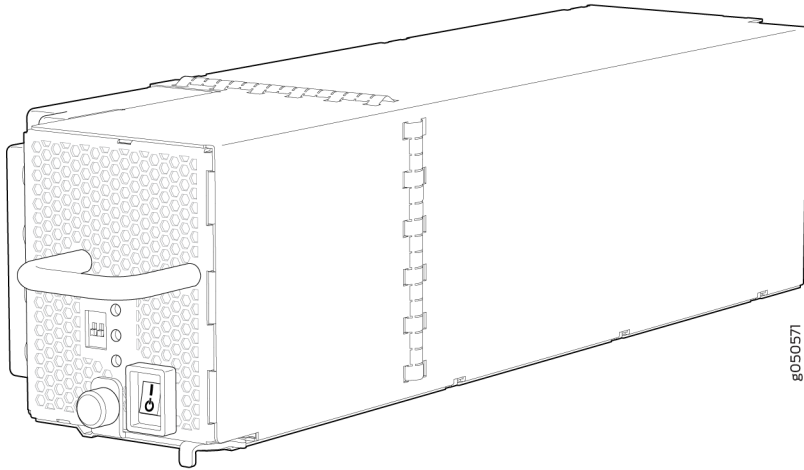


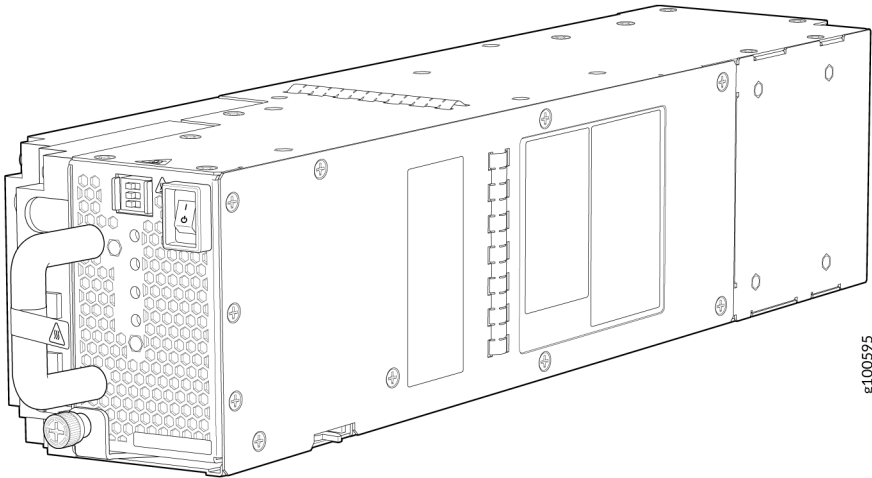
Figure 10: JNP10K-PWR-AC2 Power Supply



**Figure 11: QFX10000-PWR DC Power Supply**



**Figure 12: QFX10000-PWR-DC Power Supply**



[Table 1 on page 11](#) provides an overview of the differences among the power supplies.

## Software

The Juniper Networks QFX Series Ethernet Switches runs the Junos operating system (Junos OS), which provides Layer 2 and Layer 3 switching, routing, and security services. The same Junos OS code base that runs on QFX Series switches also runs on all Juniper Networks ACX Series, EX Series, M Series, MX Series, and T Series routers and SRX Series Firewalls.



## QFX10008 Configurations and Upgrade Options

### IN THIS SECTION

- [QFX10008 Configurations | 14](#)
- [Upgrade Kits | 17](#)

### QFX10008 Configurations

[Table 2 on page 14](#) lists the four hardware configurations for a QFX10008 modular chassis—base (AC version), redundant (AC and DC versions), and redundant (HVAC, DC, and HVDC)—and the components included in each configuration.

**Table 2: QFX10008 Hardware Configurations**

Switch Configuration	Configuration Components
Base AC configuration QFX10008-BASE	<ul style="list-style-type: none"> <li>● Chassis</li> <li>● One QFX10000-RE Routing and Control Board (RCB)</li> <li>● Two QFX10008-FAN-CTRL fan tray controllers</li> <li>● Two QFX10008-FAN fan trays</li> <li>● Three QFX10000-PWR-AC power supplies</li> <li>● Three power supply covers</li> <li>● Six power cords</li> <li>● Five QFX10008-SF Switch Interface Boards (SIBs)</li> <li>● One RCB/SSD cover</li> <li>● One SIB cover</li> <li>● Eight line card covers</li> <li>● Front door</li> </ul>

Table 2: QFX10008 Hardware Configurations (*Continued*)

Switch Configuration	Configuration Components
Base HVAC/HVDC configuration QFX10008-BASE-H	<ul style="list-style-type: none"> <li>• Chassis</li> <li>• One Routing and Control Board (RCB)</li> <li>• Two QFX10008-FAN-CTRL fan tray controllers</li> <li>• Two QFX10008-FAN fan trays</li> <li>• Three JNP10K-PWR-AC2 power supplies</li> <li>• Three power supply covers</li> <li>• Six CG_CBL-HVDC-02 power cords</li> <li>• Five Switch Interface Boards (SIBs)</li> <li>• One RCB/SSD covers</li> <li>• One SIB covers</li> <li>• Eight line card covers</li> <li>• Front door</li> </ul>
Redundant AC configuration QFX10008-REDUND	<ul style="list-style-type: none"> <li>• Chassis,</li> <li>• Two QFX10000-RE RCBs</li> <li>• Two QFX10008-FAN-CTRL fan tray controllers</li> <li>• Two QFX10008-FAN fan trays</li> <li>• Six QFX10000-PWR-AC power supplies</li> <li>• Twelve power cords</li> <li>• Six QFX10008-SF SIBs</li> <li>• Eight line card covers</li> <li>• Front door</li> </ul>

Table 2: QFX10008 Hardware Configurations (*Continued*)

Switch Configuration	Configuration Components
Redundant HVAC/HVDC configuration  QFX10008-REDUND-H	<ul style="list-style-type: none"> <li>• Chassis,</li> <li>• Two QFX10000-RE RCBs</li> <li>• Two QFX10008-FAN-CTRL fan tray controllers</li> <li>• Two QFX10008-FAN fan trays</li> <li>• Six JNP10K-PWR-AC2 power supplies</li> <li>• Twelve power cords</li> <li>• Six QFX10008-SF SIBs</li> <li>• Two RCB/SSD cover</li> <li>• Eight line card covers</li> <li>• Front door</li> </ul>
Redundant DC configuration  QFX10008-REDUND-DC	<ul style="list-style-type: none"> <li>• Chassis,</li> <li>• Two RCBs</li> <li>• Two fan tray controllers</li> <li>• Two fan trays</li> <li>• Six QFX10000-PWR-DC power supplies</li> <li>• Six SIBs</li> <li>• Eight line card covers</li> <li>• Front door</li> </ul>

**NOTE:** You can install up to eight line cards (any combination of line cards) in the switch.

**NOTE:** Line cards, the cable management system, and the SATA solid state drive are not part of the base or redundant configurations. You must order them separately.

**NOTE:** If you want to purchase additional power supplies (AC, DC, HVAC, or HVDC) SIBs, or RCBs for your switch configuration, you must order them separately.

## Upgrade Kits

If you would like to be using newer technologies, such as 14.4 Tbps line cards, you can upgrade your QFX10008 hardware configurations to become one of the newer PTX10008 hardware offerings. You can convert your QFX10008 switch to a PTX10008 router using an upgrade kit. Upgrading requires JNP10008-FAN2, JNP10008-FTC2 cooling system, and 5550 W power supplies. Depending on whether you already have the newer cooling system and power supplies will determine your upgrade kit. You can use [Table 3 on page 17](#) to find the right upgrade kit.

**Table 3: Upgrade Kit Matrix**

Original Configuration	Upgrading to Configuration	Current Power and Cooling	Order Power Supply Upgrade Kit
QFX10008-BASE	PTX10008-BASE3	QFX10000-PWR-AC and QFX10008-FAN	PTX10008-AC-UPGKIT and PTX10008-B3-UPGKIT
	PTX10008-PREM2	QFX10000-PWR-AC and QFX10008-FAN	PTX10008-AC-UPGKIT and PTX10008-P2-UPGKIT
	PTX10008-PREM3	QFX10000-PWR-AC and QFX10008-FAN	PTX10008-AC-UPGKIT and PTX10008-P3-UPGKIT
QFX10008-BASE-H	PTX10008-BASE3	QFX10000-PWR-AC2 and QFX10008-FAN	PTX10008-B3-UPGKIT
	PTX10008-PREM2	QFX10000-PWR-AC2 and QFX10008-FAN	PTX10008-P2-UPGKIT

**Table 3: Upgrade Kit Matrix (Continued)**

Original Configuration	Upgrading to Configuration	Current Power and Cooling	Order Power Supply Upgrade Kit
	PTX10008-PREM3	QFX10000-PWR-AC2 and QFX10008-FAN	PTX10008-P3-UPGKIT
QFX10008-REDUND	PTX10008-BASE3	QFX10000-PWR-AC and QFX10008-FAN	PTX10008-AC-UPGKIT and PTX10008-B3-UPGKIT
	PTX10008-PREM2	JNP10K-PWR-AC2 and JNP10008-FAN2	PTX10008-AC-UPGKIT and PTX10008-P2-UPGKIT
	PTX10008-PREM3	JNP10K-PWR-DC and JNP10008-FAN	PTX10008-AC-UPGKIT and PTX10008-P3-UPGKIT
QFX10008-REDUND-DC	PTX10008-BASE3	QFX10000-PWR-DC and QFX10008-FAN	PTX10008-DC-UPGKIT and PTX10008-B3-UPGKIT
	PTX10008-PREM2	QFX10000-PWR-DC and QFX10008-FAN	PTX10008-DC-UPGKIT and PTX10008-P2-UPGKIT
	PTX10008-PREM3	QFX10000-PWR-DC and QFX10008-FAN	PTX10008-DC-UPGKIT and PTX10008-P3-UPGKIT
QFX10008-REDUND-H	PTX10008-BASE3	QFX10000-PWR-AC2 and QFX10008-FAN	PTX10008-B3-UPGKIT
	PTX10008-PREM2	QFX10000-PWR-AC2 and QFX10008-FAN	PTX10008-P2-UPGKIT
	PTX10008-PREM3	QFX10000-PWR-AC2 and QFX10008-FAN	PTX10008-P3-UPGKIT

**NOTE:** You can install up to eight line cards that support any switch fabric compatible line card in the QFX10008.

**NOTE:** Line cards and the cable management system are not part of the base or redundant configurations. You must order them separately.

## SEE ALSO

[QFX10008 Chassis Physical Specifications](#) | 159

## QFX10000 Hardware and CLI Terminology Mapping

This topic describes the hardware terms used in QFX10000 documentation and the corresponding terms used in the Junos OS CLI. See [Table 4 on page 19](#).

**Table 4: CLI Equivalents of Terms Used in Documentation for QFX10000 Switches**

Hardware Item (CLI)	Description (CLI)	Value (CLI)	Item In Documentation	Additional Information
Chassis	QFX10008 QFX10016	-	Switch chassis	" <a href="#">QFX10008 Physical Specifications</a> " on page 159 and " <a href="#">QFX10016 Chassis Physical Specifications</a> "
Routing and Control Board	CB ( <i>n</i> )	<i>n</i> is a value in the range of 0–1.  Multiple line items appear in the CLI if more than one RCB (CB) is installed in the chassis.		" <a href="#">QFX10000 Routing and Control Board</a> " on page 81

Table 4: CLI Equivalents of Terms Used in Documentation for QFX10000 Switches (*Continued*)

Hardware Item (CLI)	Description (CLI)	Value (CLI)	Item In Documentation	Additional Information
FPC ( <i>n</i> )	Abbreviated name of the Flexible PIC Concentrator (FPC)  On QFX10008 and QFX10016, an FPC equates to a line card.	<i>n</i> is a value in the range of 0–7 for the QFX10008 and 0–15 for the QFX10016. The value corresponds to the line card slot number in which the line card is installed.	Line card (The switch does not have actual FPCs—the line cards are the FPC equivalents on the switch.)	<a href="#">Understanding Interface Naming Conventions</a>
Xcvr ( <i>n</i> )	Abbreviated name of the transceiver	<i>n</i> is a value equivalent to the number of the port in which the transceiver is installed.	Optical transceivers	<a href="#">"QFX10000 Optical Transceiver and Cable Support" on page 171</a>
PSU ( <i>n</i> )	One of the following: <ul style="list-style-type: none"> <li>• QFX10000-PWR-AC</li> <li>• QFX10000-PWR-DC</li> <li>• JNP10K-PWR-AC2</li> <li>• JNP10K-PWR-DC2</li> </ul>	<i>n</i> is a value in the range of 0–5. The value corresponds to the power supply slot number.	AC, DC, HVAC, or HVDC	<ul style="list-style-type: none"> <li>• <a href="#">"QFX10000-PWR-AC Power Supply" on page 45</a></li> <li>• <a href="#">JNP10K-PWR-AC2 Power Supply</a></li> <li>• <a href="#">"QFX10000-PWR-DC Power Supply" on page 66</a></li> <li>• <a href="#">JNP10K-PWR-DC2 Power Supply</a></li> </ul>
Fan tray	QFX10008-FAN  JNP10008-FAN2  QFX10016-FAN	–	Fan tray	<a href="#">"QFX10008 Cooling System and Airflow "</a> <a href="#">on page 32</a>  <a href="#">QFX10016 Cooling System and Airflow</a>

Table 4: CLI Equivalents of Terms Used in Documentation for QFX10000 Switches (*Continued*)

Hardware Item (CLI)	Description (CLI)	Value (CLI)	Item In Documentation	Additional Information
SIB ( <i>n</i> )	<p>This field indicates:</p> <ul style="list-style-type: none"> <li>• State of the fabric plane: <ul style="list-style-type: none"> <li>• Active</li> <li>• Spare</li> <li>• Check State</li> </ul> </li> <li>• Status of the Packet Forwarding Engine in each fabric plane: <ul style="list-style-type: none"> <li>• Links OK</li> <li>• Error</li> </ul> </li> </ul>	<i>n</i> is a value in the range of 0–5.	Fabric plane	<a href="#"><i>show chassis fabric sibs</i></a>
PIC ( <i>n</i> )	–	Value of <i>n</i> is always 0.	–	<a href="#"><i>Understanding Interface Naming Conventions</i></a>

## QFX10000 Component Redundancy

The QFX10000 is designed so that no single point of failure can cause the entire system to fail. The following major hardware components in the redundant configuration provide redundancy:

- Routing and Control Board (RCB)—The RCB consolidates the Routing Engine function with control plane function in a single unit. The QFX10000 can have one or two RCBs. When two RCBs are installed, one functions as the primary and the other functions as the backup. If the primary RCB (or



either of its components) fails, the backup can take over as the primary. See "[QFX10000 Routing and Control Board Description](#)" on page 81.

- **Switch Interface Boards (SIBs)**—The QFX10000 has six SIB slots. Five SIBs are required for base operation and the sixth SIB provides  $n+1$  redundancy. All six SIBs are active and can sustain full throughput rate. The fabric plane can tolerate one SIB failure without any loss of performance. See the "[QFX10008 Switch Interface Board Description](#)" on page 77 and [QFX10016 Switch Interface Board Description](#).
- **Power supplies**—The QFX10000 requires three power supplies for minimum operation (two RCBs, two fan trays, six SIBs and no line cards). With additional power supplies, it provides  $n+1$  redundancy for the system. AC, DC, HVAC, and HVDC systems tolerate a single power supply to fail without system interruption. If one power supply fails in a fully redundant system, the other power supplies can provide full power to the QFX10000 indefinitely.

The QFX10000 also supports source redundancy. Two sets of lugs are provided for the QFX10000-PWR-AC cables, four sets of lugs are provided for the JNP10K-PWR-DC2 cables, and two AC power cords are provided for each JNP10K-PWR-AC2 power supply.

- **Cooling system**—The fan trays have redundant fans, which are controlled by the fan tray controller. If one of the fans fails, the host subsystem increases the speed of the remaining fans to provide sufficient cooling for the switch indefinitely. See "[QFX10008 Cooling System and Airflow](#)" on page 32 and [QFX10016 Cooling System and Airflow](#).

## RELATED DOCUMENTATION

---

[QFX10008 Cooling System](#) | 32

---

[QFX10008 Chassis](#) | 23

---

[QFX10000 Routing and Control Board Description](#) | 81

---

[QFX10000-PWR-AC Power Supply](#) | 45

---

[QFX10000-PWR-DC Power Supply](#) | 66

---

[QFX10008 Switch Interface Board](#) | 77

# QFX10008 Chassis

## IN THIS SECTION

- [QFX10000 Field-Replaceable Units | 23](#)
- [QFX10000 Status Panel | 25](#)
- [QFX10000 EMI Front Panel | 27](#)
- [QFX10000 Optional Equipment | 29](#)

## QFX10000 Field-Replaceable Units

Field-replaceable units (FRUs) are switch components that you can replace at your site. The switch uses these types of FRUs:

- Hot-insertable and hot-removable—You can remove and replace these components without powering off the switch or disrupting the switching function.
- Hot-pluggable—You can remove and replace these components without powering off the switch, but the switching function is interrupted until you replace the component.

[Table 5 on page 23](#) lists the FRUs and their types for the QFX10000.

**Table 5: FRUs in an QFX10000**

FRU	Type
Power supplies	Hot-insertable and hot-removable.
Fan tray	Hot-insertable and hot-removable.
Fan tray controller	Hot-insertable and hot-removable.

Table 5: FRUs in an QFX10000 (Continued)

FRU	Type
Routing Control Board (RCB)	<p>Redundant configuration:</p> <ul style="list-style-type: none"> <li>• Primary RCB is hot-pluggable.</li> <li>• Backup RCB is hot-insertable and hot-removable.</li> </ul> <p>Base configuration:</p> <ul style="list-style-type: none"> <li>• Removal of the RCB will cause the switch to shut down. You can install a replacement RCB in the second slot. The system will restart to elect a primary and backup. If necessary, you can switch the primary and backup using the request chassis routing-engine master switch command.</li> </ul> <p>See "<a href="#">QFX10008 Configurations and Upgrade Options</a>" on page 14 and <a href="#">QFX10016 Components and Configurations</a>.</p>
Switch Interface Boards (SIBs)	<p>SIBs are hot-insertable and hot-removable. We recommend that you take SIBs offline before removing them to avoid traffic loss while the switch fabric is being reconfigured. For example:</p> <pre>user@switch&gt; request chassis sib (offline   online) slot <i>slot-number</i> offline</pre>
Line cards	<p>Hot-insertable and hot-removable. We recommend that you take line cards offline before removing them. For example:</p> <pre>user@switch&gt; request chassis fpc slot <i>slot-number</i> offline</pre>
Optical transceivers  See the <a href="#">Hardware Compatibility Tool</a> .	Hot-insertable and hot-removable.

**NOTE:** Line cards are not part of the base or redundant configuration. You must order them separately.

**NOTE:** If you have a Juniper Care service contract, register any addition, change, or upgrade of hardware components at <https://www.juniper.net/customers/support/tools/updateinstallbase/>. Failure to do so can result in significant delays if you need replacement parts. This note does not apply if you replace an existing component with the same type of component.

## QFX10000 Status Panel

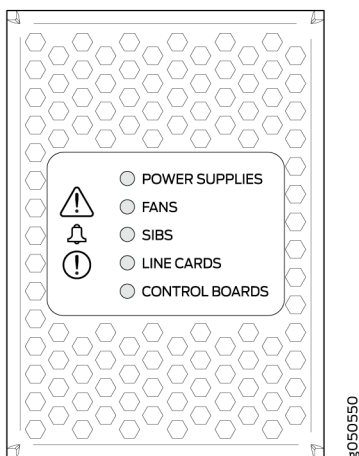
The status panel of the QFX10008 and QFX10016 has two purposes:

- Shows the overall status of the chassis
- Indicates the type of power bus internal to the chassis

Some chassis ship with an enhanced power bus to support the power needs of higher wattage line cards.

The status panel indicates chassis status through a set of five bi-color LEDs. See [Figure 13 on page 25](#) for chassis with the original power bus.

**Figure 13: Status Panel**



Other chassis have the same set of five bi-color LEDs, but also have an azure blue line to indicate the enhanced power bus (see [Figure 14 on page 26](#)).

Figure 14: Status Panel on Chassis with the Enhanced Power Bus

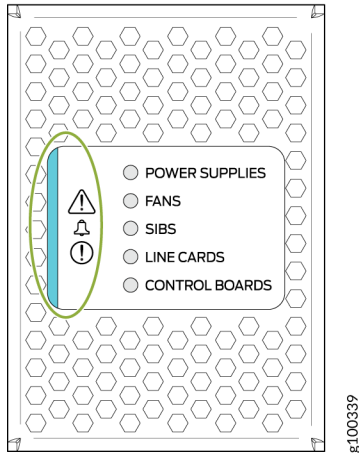


Table 6 on page 26 describes the status panel LEDs.

Table 6: Status Panel LEDs in a QFX10000

Name	Color	State	Description
Power supplies	Green	On steadily	All of the power supplies are online and operating normally.
	Yellow	On steadily	One or more of the power supplies has an error.
	None	Off	None of the power supplies is receiving power.
Fans	Green	On steadily	The fans and the fan tray controllers are online and operating normally.
	Yellow	On steadily	There is an error in a fan or in one of the fan tray controllers.
	None	Off	The fan tray controllers and fan trays are not receiving power.

**Table 6: Status Panel LEDs in a QFX10000 (Continued)**

Name	Color	State	Description
SIBs	Green	On steadily	All installed Switch Interface Boards (SIBs) are online.
	Yellow	On steadily	There is an error in one or more SIBs.
	None	Off	One or more SIBs are offline.
Line cards	Green	On steadily	All installed line cards are online.
	Yellow	On steadily	One or more line cards have an error condition.
	None	Off	One or more line cards are offline.
Routing Control Boards	Green	On steadily	All installed RCBs are online.
	Yellow	Blinking	One or more RCBs have an error condition.
	None	Off	The installed RCBs are offline.

**SEE ALSO**

[QFX10000 Troubleshooting Resources Overview | 341](#)

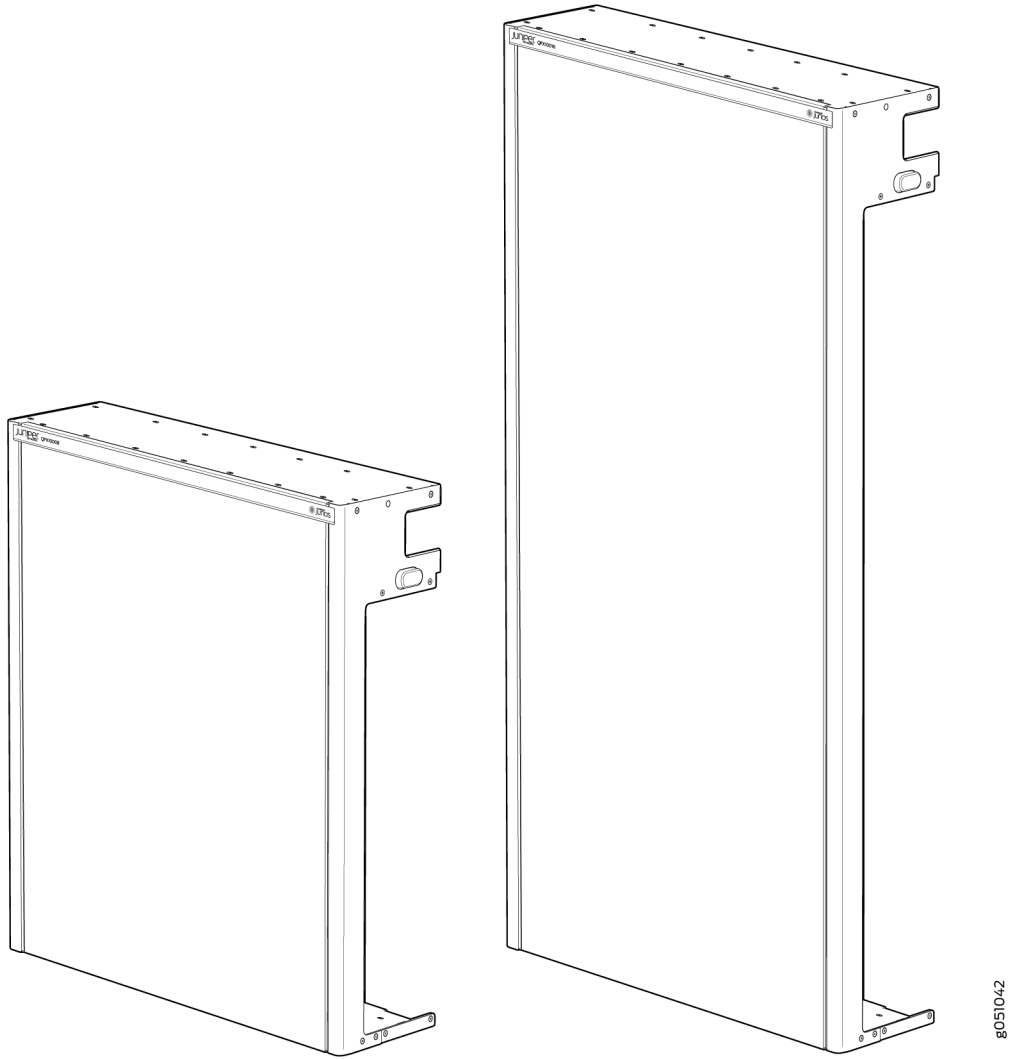
[QFX10000 Line Cards | 88](#)

## QFX10000 EMI Front Panel

The QFX10000 modular chassis models come equipped with a screened door, or panel, that provides additional electromagnetic interference (EMI) protection.

The panel attaches to the front of the chassis and swings open to allow easy access to optics and line cards, see [Figure 15 on page 28](#) and [Table 7 on page 28](#).

**Figure 15: QFX10008 and QFX10016 EMI Front Panels**



**Table 7: QFX10000 EMI Door Specifications**

Model	Dimensions	Weight
QFX10008	22.25 in. H x 17.70 in. W x 6.10 in. D	12.8 lb

Table 7: QFX10000 EMI Door Specifications (Continued)

Model	Dimensions	Weight
QFX10016	36.43 in. H x 17.70 in. W x 6.10 in. D	20.3 lb

**SEE ALSO**

[Installing the Front Panel on a QFX10000 | 207](#)

## QFX10000 Optional Equipment

**IN THIS SECTION**

- [QFX10000 Cable Management System | 29](#)
- [QFX10000 SATA SSD | 31](#)

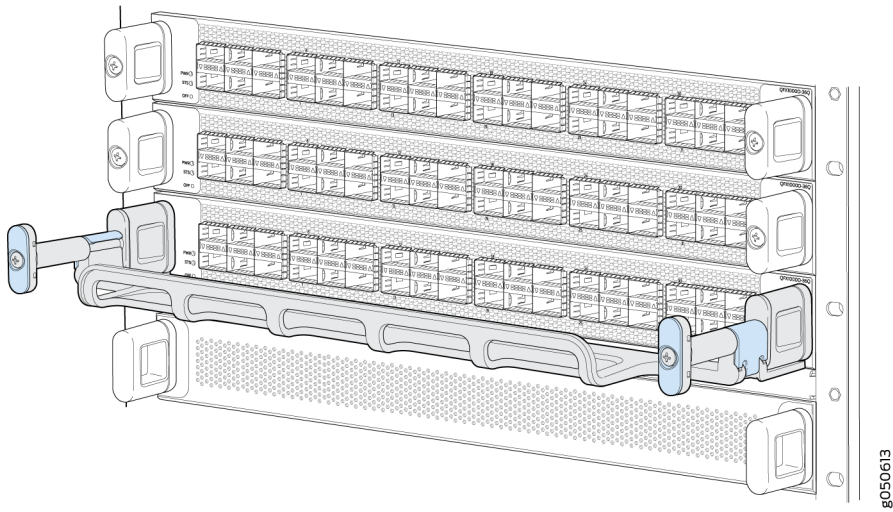
The QFX10000 line of modular chassis switches supports the following optional equipment and systems:

### QFX10000 Cable Management System

The QFX10000 cable management system (see [Figure 16 on page 30](#)) enables you to route optical cables away from the line card ports for better airflow through the chassis. Using this optional system also makes it easier to use cable ties or strips to organize the cabling.

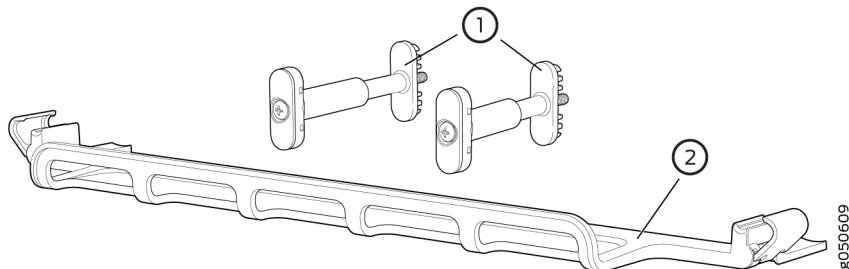


Figure 16: QFX10000 Cable Management System



The cable management system is comprised of a set of handle extensions and a tray that snaps to the extensions (see [Figure 17 on page 30](#)) for an individual line card. The handle extensions can be used with or without the cable tray. It is not necessary to remove the handle extensions if you want to remove a line card.

Figure 17: Cable Management Parts

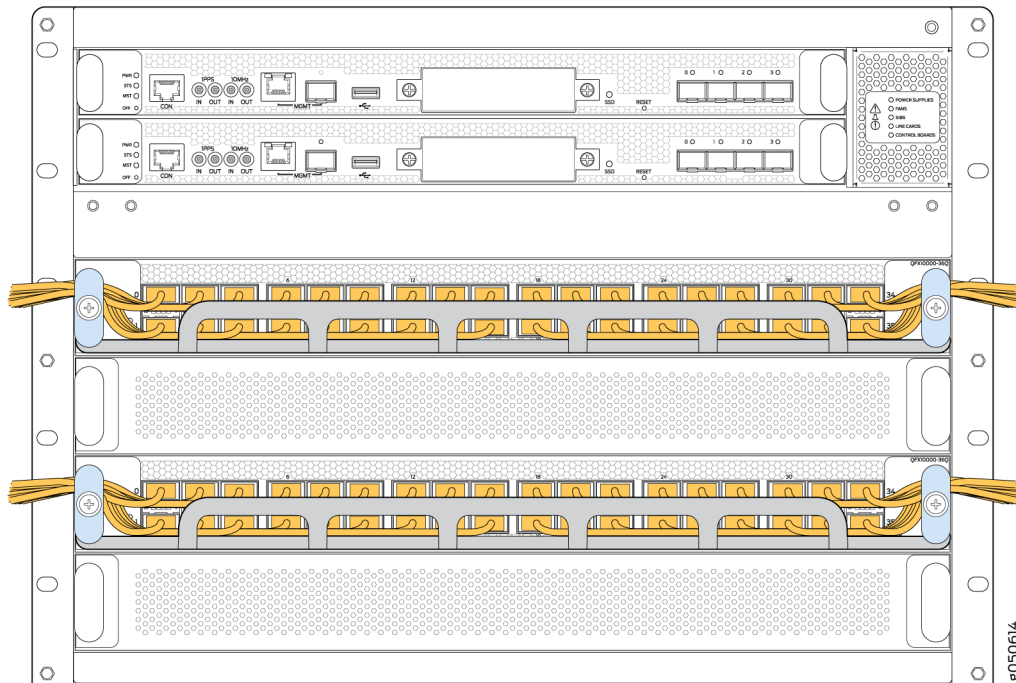


1– Handle extensions

2– Cable tray

Cables are draped across or under the handle extensions and then secured with cable wraps (see [Figure 18 on page 31](#)).

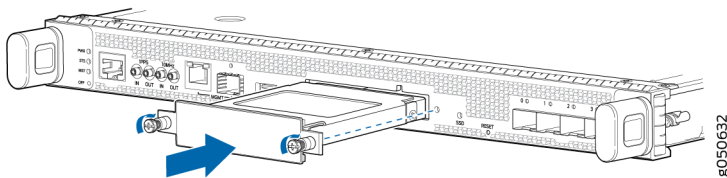
Figure 18: Two Cable Management Systems Installed on QFX10016



## QFX10000 SATA SSD

The QFX10000 line of modular chassis switches allows you to install one of two Serial Advanced Technology Attachment (SATA) solid-state drives (SSDs) as a secondary boot drive or for log storage. The drive is available in either a 50 GB or 100 GB version. The SATA SSD is field-replaceable unit (FRU) that is installed in the front panel of a Routing and Control Board (see [Figure 19 on page 31](#)).

Figure 19: SATA SSD



## SEE ALSO

[Installing the QFX10000 Cable Management System | 316](#)

| [Installing the Optional SATA Solid State Drive in a QFX10000](#) | 321

### RELATED DOCUMENTATION

| [QFX10008 Configurations and Upgrade Options](#) | 14

| [QFX10000 Optical Transceiver and Cable Support](#) | 171

## QFX10008 Cooling System

### IN THIS SECTION

- [QFX10008 Cooling System and Airflow](#) | 32
- [QFX10000 Fan Tray LEDs and Fan Tray Controller LEDs](#) | 37

The QFX10008 cooling system components work together to keep all components within the acceptable temperature range. If the maximum temperature specification is exceeded and the system cannot be adequately cooled, the Routing and Control Board shuts down some or all of the hardware components.

## QFX10008 Cooling System and Airflow

### IN THIS SECTION

- [Fan Trays](#) | 33
- [Fan Tray Controllers](#) | 34
- [Airflow Direction in the QFX10008](#) | 36

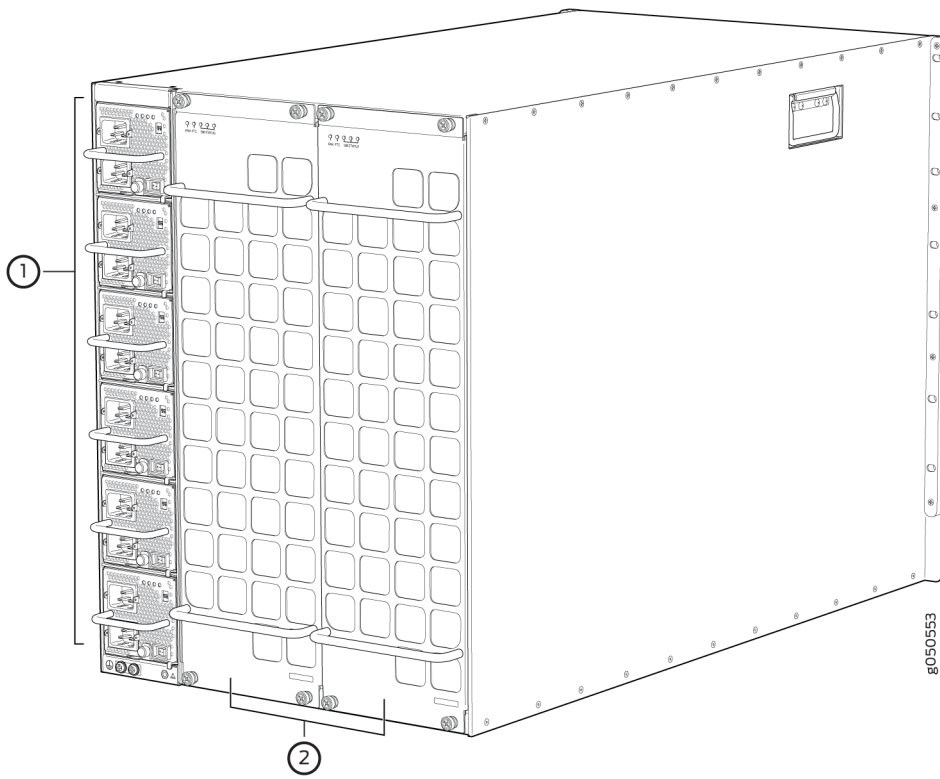
The cooling system in a QFX10008 chassis consists of dual fan trays and dual fan tray controllers.

## Fan Trays

Each fan tray is a hot-insertable and hot-removable FRU. Each fan tray contains 11 fans, a non-removable control board, and LEDs.

The two fan trays install vertically, side by side, next to the power supplies on the FRU side of the chassis. Two handles on each front faceplate facilitate handling of the fan tray. See [Figure 20 on page 33](#).

**Figure 20: Installed Fan Trays in a QFX10008**



1– QFX10000-PWR-AC power supplies

2– QFX10008-FAN fan trays

See [Table 8 on page 33](#) for the physical specifications for the fan trays.

**Table 8: Fan Tray Specifications**

Specification	Value
Height	22.4 in. (56.9 cm)

**Table 8: Fan Tray Specifications (Continued)**

Specification	Value
Width	6.6 in. (16.8 cm)
Depth	4.0 in. (10.2 cm) without handles, 5.2 in. (13.2 cm) with handles
Weight	11.8 lb (5.4 kg)
Number of fans per fan tray	11
Number of fans per chassis	22
Volume flow at 100%	1437.37 CFM per fan tray

Only remove one fan tray when replacing an existing fan tray while the switch is running. The switch continues to operate for a limited time with a single operating fan tray without triggering a thermal alarm.



**CAUTION:** To avoid a thermal alarm, do not remove both fan trays while the switch is operating.



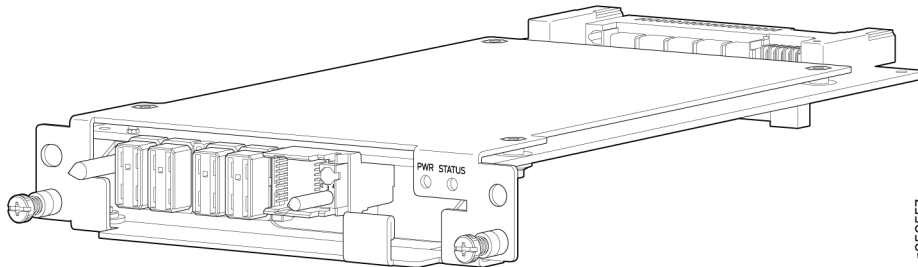
**CAUTION:** The chassis will shut down if a thermal alarm is raised for more than three minutes.

The internal fan Control Board in each fan tray contains the LEDs for the associated fan tray controllers and the LEDs for the three Switch Interface Boards (SIBs) directly behind the fan tray.

## Fan Tray Controllers

The two fan tray controllers provide the control logic and power to hot-insert and hot-remove a fan tray. The fans in each fan tray are numbered 0 through 20. See [Figure 21 on page 35](#).

Figure 21: Fan Tray Controller QFX10008-FAN-CTRL



The system continually monitors the temperature of critical parts across the chassis and adjusts the chassis fan speed according to the temperature.

Software controls the fan speed. Under normal operating conditions, the fans in the fan tray run at less than full speed. If one fan tray controller fails or appears missing (such as when a SIB is being replaced) the other fan tray controller sets the fans to full speed. This allows the switch to continue to operate normally as long as the remaining fans cool the chassis sufficiently. Use the `show chassis fan` command to see the status of individual fans and fan speed. The following example shows the fan status for a system running QFX1008-FAN and QFX10008-FAN-CTRL

```

root> show chassis fan
  Item                Status  RPM    Measurement
  Fan Tray 0 Fan 0    OK      6300   Spinning at normal speed
  Fan Tray 0 Fan 1    OK      6150   Spinning at normal speed
  Fan Tray 0 Fan 2    OK      6300   Spinning at normal speed
  Fan Tray 0 Fan 3    OK      6300   Spinning at normal speed
  Fan Tray 0 Fan 4    OK      6150   Spinning at normal speed
  Fan Tray 0 Fan 5    OK      6000   Spinning at normal speed
  Fan Tray 0 Fan 6    OK      6150   Spinning at normal speed
  Fan Tray 0 Fan 7    OK      6150   Spinning at normal speed
  Fan Tray 0 Fan 8    OK      6150   Spinning at normal speed
  Fan Tray 0 Fan 9    OK      6300   Spinning at normal speed
  Fan Tray 0 Fan 10   OK      6300   Spinning at normal speed
  Fan Tray 1 Fan 0    OK      6300   Spinning at normal speed
  Fan Tray 1 Fan 1    OK      6150   Spinning at normal speed
  Fan Tray 1 Fan 2    OK      6300   Spinning at normal speed
  Fan Tray 1 Fan 3    OK      6150   Spinning at normal speed
  Fan Tray 1 Fan 4    OK      6300   Spinning at normal speed
  Fan Tray 1 Fan 5    OK      6300   Spinning at normal speed
  Fan Tray 1 Fan 6    OK      6150   Spinning at normal speed
  Fan Tray 1 Fan 7    OK      6150   Spinning at normal speed

```

Fan Tray 1 Fan 8	OK	6150	Spinning at normal speed
Fan Tray 1 Fan 9	OK	6150	Spinning at normal speed
Fan Tray 1 Fan 10	OK	6300	Spinning at normal speed
root>			

See [Table 9 on page 36](#) for the physical specifications for the fan tray controller.

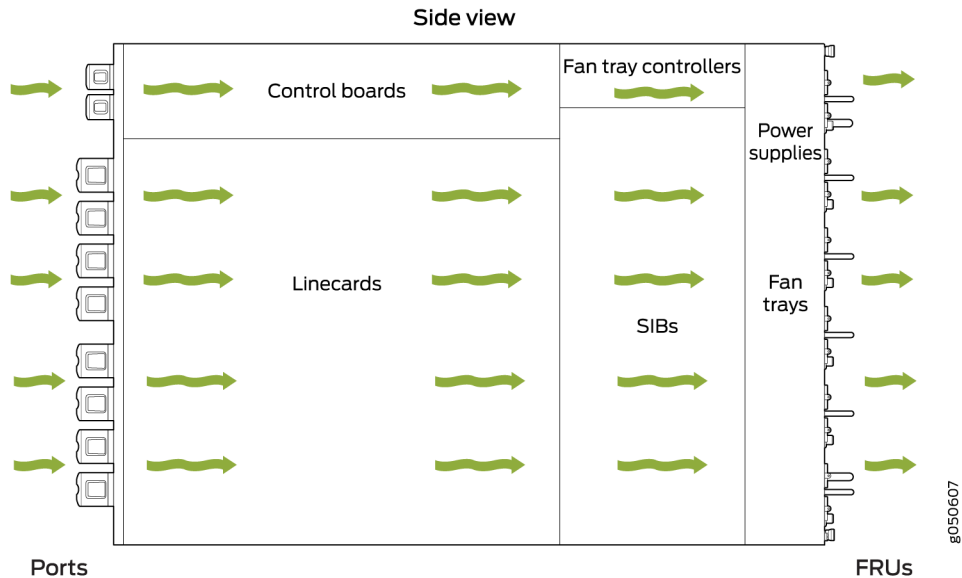
**Table 9: Fan Tray Controller Specifications**

Specification	Value
Height	1.5 in. (3.81 cm)
Width	6.5 in. (15.24 cm)
Depth	9.3 in. (23.62 cm)
Weight	1.5 lb (0.68 kg)

### Airflow Direction in the QFX10008

The air intake to cool the chassis is located on the port (line card) side of the chassis. Air flows into the chassis from the ports in the RCBs and line cards, through the SIBs, and exits from the fan trays and the power supplies. This airflow is called port-to-FRU cooling or airflow out (AFO). See [Figure 22 on page 37](#).

Figure 22: Airflow Through a QFX10008



The fan tray continues to operate indefinitely and provide sufficient cooling even when a single fan fails, provided the room temperature is within the operating range. You can check the status of fans by viewing the LEDs on each fan tray.

You cannot replace a single fan. If one or more fans fail, you must replace the entire fan tray.

In addition to the fan trays, there is an internal fan in each power supply.

#### SEE ALSO

[QFX10000 Field-Replaceable Units | 23](#)

## QFX10000 Fan Tray LEDs and Fan Tray Controller LEDs

#### IN THIS SECTION

- [Fan Tray LEDs | 38](#)
- [Fan Tray Controller LEDs | 43](#)

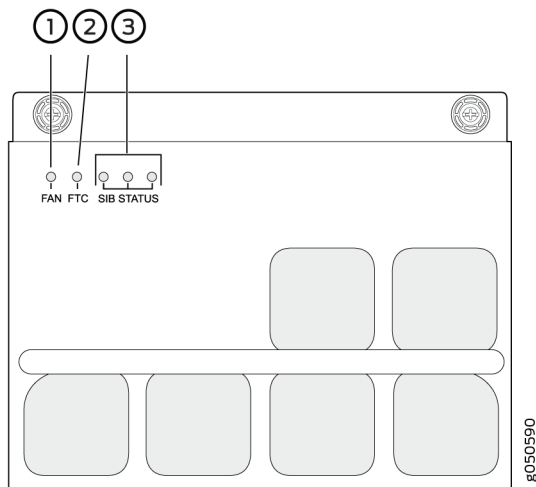


Each fan tray has a set of LEDs, and each corresponding fan tray controller also has a set of LEDs.

### Fan Tray LEDs

The two fan trays have a set of LEDs that represent the status of the fans in the fan tray, the fan tray controller, and the three Switch Interface Boards (SIBs). The fan tray LEDs are located in the top left corner of each fan tray. [Figure 23 on page 38](#) shows the location of the LEDs on the QFX10008-FAN and QFX10016-FAN fan tray.

**Figure 23: Fan Tray QFX10000-FAN LEDs**



1- Fan status LED

3- SIB status (SIB 0 through SIB 2 for the left fan tray and SIB 3 through 5 for the right fan tray)

2- Fan tray controller status

[Table 10 on page 38](#) describes the functions of the fan tray LEDs.

**Table 10: Fan Tray LEDs on a QFX10000 Switch**

Name	Color	State	Description
Fan status	Green	On steadily	All fans are operating normally. The system has verified that the fan tray is engaged, that the airflow is in the correct direction, and that all fans are operating correctly.

Table 10: Fan Tray LEDs on a QFX10000 Switch (Continued)

Name	Color	State	Description
	Green	Blinking	The beacon feature is enabled. This feature is enabled using the request chassis beacon command.
	Yellow	Blinking	An error has been detected in one or more fans in the fan tray. Replace the fan tray as soon as possible. Either the fan has failed or it has become disconnected. To maintain proper airflow through the chassis, leave the fan tray installed in the chassis until you are ready to replace it.
	None	Off	The fan is not receiving power from the fan tray controller.
Fan tray controller status	Green	On steadily	The fan tray controller is online and is operating normally.
	Green	Blinking	The beacon feature is enabled. This feature is enabled using the request chassis beacon command.
	Yellow	Blinking	An error has been detected in the fan tray controller. Replace the fan tray controller as soon as possible. The fan tray controller is located behind the fan tray above the SIBs. To maintain proper airflow through the chassis, leave the fan tray installed in the chassis until you are ready to replace the fan tray controller.
	None	Off	The fan tray controller is not receiving power.

Table 10: Fan Tray LEDs on a QFX10000 Switch (Continued)

Name	Color	State	Description
SIB 0 status	Green	On steadily	The left-most SIB in the chassis is online.
	Green	Blinking	The beacon feature is enabled. This feature is enabled using the request chassis beacon command.
	Yellow	Blinking	An error has been detected in SIB 0. Replace the SIB as soon as possible. The SIB is located behind the left fan tray and is the left-most SIB in the chassis. To maintain proper airflow through the chassis, leave the fan tray installed in the chassis until you are ready to replace the SIB.
	None	Off	The SIB is offline.
SIB 1 status	Green	On steadily	The center SIB behind the left fan tray is online.
	Green	Blinking	The beacon feature is enabled. This feature is enabled using the request chassis beacon command.
	Yellow	Blinking	An error has been detected in SIB 1. Replace the SIB as soon as possible. The SIB is located behind the left fan tray and is the middle SIB in the grouping of 3. To maintain proper airflow through the chassis, leave the fan tray installed in the chassis until you are ready to replace the SIB.
	None	Off	The SIB is offline.

Table 10: Fan Tray LEDs on a QFX10000 Switch (Continued)

Name	Color	State	Description
SIB 2 status	Green	On steadily	The right-most SIB behind the left fan tray is online.
	Green	Blinking	The beacon feature is enabled. This feature is enabled using the request chassis beacon command.
	Yellow	Blinking	An error has been detected in SIB 2. Replace the SIB as soon as possible. The SIB is located behind the left fan tray and is the right-most SIB in the grouping of 3. To maintain proper airflow through the chassis, leave the fan tray installed in the chassis until you are ready to replace the SIB.
	None	Off	The SIB is offline.
SIB 3 status	Green	On steadily	The left-most SIB behind the right fan tray is online.
	Green	Blinking	The beacon feature is enabled. This feature is enabled using the request chassis beacon command.
	Yellow	Blinking	An error has been detected in SIB 3. Replace the SIB as soon as possible. The SIB is located behind the right fan tray and is the left-most SIB in the grouping of 3. To maintain proper airflow through the chassis, leave the fan tray installed in the chassis until you are ready to replace the SIB.
	None	Off	The SIB is offline.

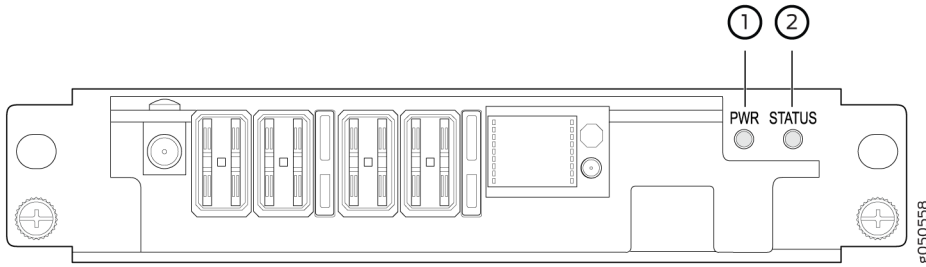
Table 10: Fan Tray LEDs on a QFX10000 Switch (Continued)

Name	Color	State	Description
SIB 4 status	Green	On steadily	The center SIB behind the right fan tray is online.
	Green	Blinking	The beacon feature is enabled. This feature is enabled using the request chassis beacon command.
	Yellow	Blinking	An error has been detected in SIB 4. Replace the SIB as soon as possible. The SIB is located behind the right fan tray and is the middle SIB in the grouping of 3. To maintain proper airflow through the chassis, leave the fan tray installed in the chassis until you are ready to replace the SIB.
	None	Off	The SIB is offline.
SIB 5 status	Green	On steadily	The right-most SIB behind the right fan tray is online.
	Green	Blinking	The beacon feature is enabled. This feature is enabled using the request chassis beacon command.
	Yellow	Blinking	An error has been detected in SIB 5. Replace the SIB as soon as possible. The SIB is located behind the right fan tray and is the right-most SIB in the grouping of 3. To maintain proper airflow through the chassis, leave the fan tray installed in the chassis until you are ready to replace the SIB.
	None	Off	The SIB is offline.

## Fan Tray Controller LEDs

The fan tray controller LEDs are only visible when the associated fan tray is removed. The fan tray controller LEDs are located on the right of the controller panel. [Figure 24 on page 43](#) shows the location of the LEDs on the QFX10000-FAN-CTRL fan tray controller panel.

**Figure 24: Fan Tray Controller LEDs on a QFX10000-FAN-CTRL**



1– Fan tray controller power

2– Fan tray controller status

[Table 11 on page 43](#) describes the functions of the fan tray controller LEDs.

**Table 11: Fan Tray Controller LEDs on a QFX100000**

Name	Color	State	Description
Fan controller power	Green	On steadily	The fan tray controller has power and is operating normally.
	Yellow	Blinking	A power error has been detected in the fan tray controller. Replace the fan tray controller as soon as possible. To maintain proper airflow through the chassis, leave the fan tray installed in the chassis until you are ready to replace the fan tray controller.
	None	Off	The fan tray controller is not powered on or is not receiving power.
Fan tray controller status	Green	On steadily	The fan tray controller is online and is operating normally.

**Table 11: Fan Tray Controller LEDs on a QFX100000 (Continued)**

Name	Color	State	Description
	Green	Blinking	The beacon feature is enabled. This feature is enabled using the request chassis beacon command.
	Yellow	Blinking	An error has been detected in the fan tray controller. Replace the fan tray controller as soon as possible. To maintain proper airflow through the chassis, leave the fan tray installed in the chassis until you are ready to replace the fan tray controller.
	None	Off	The fan tray controller is not receiving power.

**RELATED DOCUMENTATION**

[Installing a QFX10008 Fan Tray | 237](#)

[Installing a QFX10008 Fan Tray Controller | 241](#)

[QFX10000 Troubleshooting Resources Overview | 341](#)

## QFX10000 AC Power System

**IN THIS SECTION**

- [QFX10000-PWR-AC Power Supply | 45](#)
- [QFX10000-PWR-AC Power Specifications | 48](#)
- [JNP10K-PWR-AC2 Power Supply | 48](#)
- [JNP10K-PWR-AC2 Power Specifications | 51](#)

- [QFX10000 Power Cables Specifications | 52](#)
- [QFX10000 AC Power Supply LEDs | 61](#)
- [JNP10K-PWR-AC2 Power Supply LEDs | 63](#)

## QFX10000-PWR-AC Power Supply

### IN THIS SECTION

- [QFX10000-PWR-AC Power Supply Description | 45](#)

### QFX10000-PWR-AC Power Supply Description

The QFX10000-PWR-AC power supply is a 2700 W, hot-insertable, hot-removable, field-replaceable unit (FRU). You can install up to six power supplies in a QFX10008 in the slots labeled **PSU 0** through **PSU 5** (top to bottom) located in the rear of the chassis. In QFX10016, you can install up to 10 power supplies in the slots labeled **PSU 0** through **PSU 9**. Power supplies install in any available power supply slot.

The AC power supply supports 200–240 VAC. Each AC power supply has two independent 16 A rated AC inlets on the faceplate. The output is 12 VDC; the output power is 2700 W.



**WARNING:** The switch is pluggable type A equipment installed in a restricted-access location. It has a separate protective earthing terminal on the chassis that must be connected to earth ground permanently to ground the chassis adequately and protect the operator from electrical hazards.



**CAUTION:** Before you begin installing the switch, ensure that a licensed electrician has attached an appropriate grounding lug to the grounding cable that you supply. Using a grounding cable with an incorrectly attached lug can damage the switch.



**NOTE:** All base configuration QFX10008 switches are shipped with three power supplies; base configuration for QFX10016 switches are shipped with five power supplies. Covers are installed over the remaining power supply slots. You can add additional power supplies to base configuration switches as necessary. To calculate the number of additional power supplies needed for your specific system, see ["Calculating Power Requirements for a QFX10008" on page 165](#) and ["Calculating Power Requirements for a QFX10016"](#). For details about different switch configurations, see ["QFX10008 Configurations and Upgrade Options" on page 14](#) and ["QFX10016 Components and Configurations"](#).

The JNP10K-PWR-AC power supplies do not share power.

Each QFX10000-PWR-AC power supply weighs approximately 6.8 lb (3.08 kg) and has 2 independent 16 A rated AC inlets on the faceplate. Although each inlet provides sufficient input power to provide full output, always connect to a dedicated AC power feed to provide redundancy. Only one power feed is operational at a time.

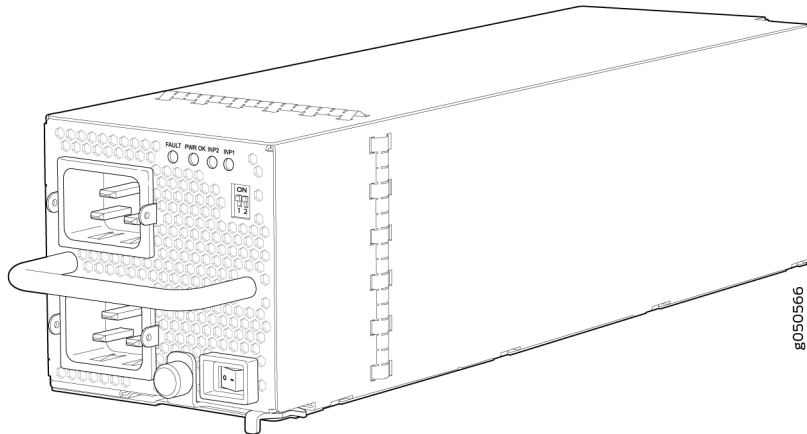
QFX10000 modular switches employ automatic transfer switch (ATS) technology. The system provides  $2n$  source redundancy and  $n+1$  power supply redundancy, allowing you to use fewer power supplies than you would require in a  $2n$  configuration. Should one power source fail, ATS switches the power supply to the alternate source.

**NOTE:** For redundancy, always plug the two power cords from each power supply:

- **INP1** into a UPS
- **INP2** into the public electricity supply

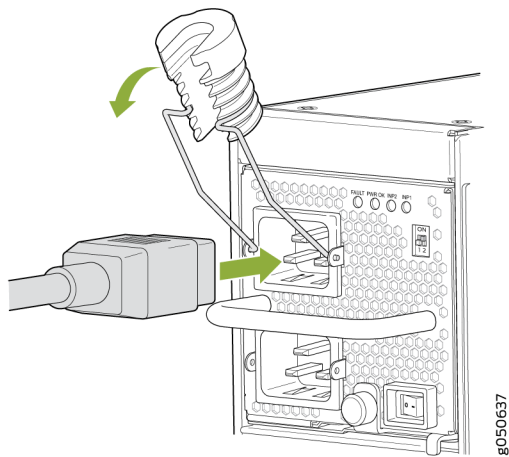
Each QFX10000-PWR-AC power supply has a power switch with international markings for on (I) and off (O), a fan, and four LEDs on the faceplate that indicate the status of the power supply. See [Figure 25 on page 47](#).

**Figure 25: QFX10000-PWR-AC Power Supply**



Each QFX10000-PWR-AC power supply comes with two power cord retainers that hold the power cords in place. See [Figure 26 on page 47](#). Each power cord retainer has a clip and an adjustment nut. The ends of the clip hook into the bracket holes on each side of the AC appliance inlet on the faceplate. The adjustment nut holds the power cord in the correct position. For instructions for installing the power cord retainers, see "[Connect AC Power to a QFX Modular Chassis](#)" on page 217.

**Figure 26: Power Cord Retainer for a QFX10000-PWR-AC Power Supply**



Each power supply connects to the power rail in the switch. The power rail distributes the output power produced by the power supplies to different switch components. Each AC power supply provides power to all the components in the switch.

Each power supply has its own fan and is cooled by its own internal cooling system. Hot air exhausts from the rear of the chassis.

## QFX10000-PWR-AC Power Specifications

Table 12 on page 48 lists the power specifications for the AC power supply used in a QFX10000 modular chassis.

**Table 12: Power Specifications for a QFX10000-PWR-AC Power Supply**

Item	Specifications
AC input voltage	Operating range: 200–240 VAC
AC input line frequency	50–60 Hz
AC input current rating	16 A
AC output power	2700 W

Table 13 on page 48 shows the physical specifications for a QFX10000-PWR-AC power supply.

**Table 13: Physical Specifications for a QFX10000-PWR-AC Power Supply**

Specification	Value
Height	3.5 in. (8.89 cm)
Width	3.6 in. (9.14 cm)
Depth	14.4 in. (6.53 cm)
Weight	6.8 lb (3.08 kg)

## JNP10K-PWR-AC2 Power Supply

The JNP10K-PWR-AC2 power supply is a high-capacity, high-line model that is designed to support either AC or DC systems in either a low-power or high-power mode. The power supply takes AC input

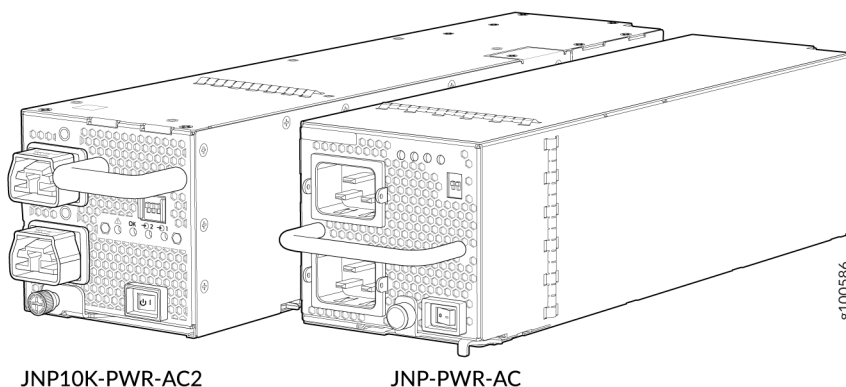
and provides DC output of 12.3 VDC, 5000 W with a single feed and 5500 W with a dual feed. For AC systems, the operating input voltage is 180 to 305 VAC and for DC systems, the operating input voltage is 190 to 410 VDC.

The number of power feeds and whether the power supplies provide high output (30-A) or low output (20-A) power is configured using a set of dual inline package (DIP) switches on the faceplate of the power supply. If one power supply in the chassis is set to low power, the power budget for the chassis is reduced to low power, regardless of their DIP switch settings or the output results in CLI. This design safeguards against accidentally setting the power supply to 30-A in a facility that can only provide 20-A and tripping the facility circuit breaker. We recommend that you do not mix DIP switch settings in your system. See [Table 14 on page 50](#).

The JNP10K-PWR-AC2 power supplies share power.

The JNP10K-PWR-AC2 fits into the standard power supply bay but when compared to most other models, the JNP10K-PWR-AC2 is longer and protrudes from the bay when fully inserted into the chassis. See [Figure 27 on page 49](#) for the settings for the dip switches.

**Figure 27: Comparison of the JNP10K-PWR-AC2 to the QFX10000-PWR-AC Power Supply**



**WARNING:** Extreme burn danger—Do not handle an HVAC or HVDC power supply running in the chassis without heat protective gloves, such as welder’s gloves. The JNP10K-PWR-AC2 can reach temperatures in the range of 158°F (70°C) to 176°F (80°C) under running conditions.



**WARNING:** The switch is pluggable type A equipment installed in a restricted-access location. It has a separate protective earthing terminal on the chassis that must be

connected to earth ground permanently to ground the chassis adequately and protect the operator from electrical hazards.



**CAUTION:** Before you begin installing the switch, ensure that a licensed electrician has attached an appropriate grounding lug to the grounding cable that you supply. Using a grounding cable with an incorrectly attached lug can damage the device.



**CAUTION:** Use a 2-pole circuit breaker rated at 25 A in the building installation and the system, or as per local electrical code.

**Table 14: Power Input and Output Voltages for JNP10K-PWR-AC2 Power Supplies**

INP0 (Switch 1)	INP1 (Switch 2)	H/L (High Input 30 A/Low Input 20A)	Output Power
On	On	On (30 A)	5500 W
On	On	Off (20 A)	3000 W
On	Off	On (30 A)	5000 W
Off	On	On (30 A)	5000 W
On	Off	Off (20 A)	2700 W
Off	On	Off (20 A)	2700 W



**CAUTION:** It is important to connect both input feeds of the JNP10K-PWR-AC2 power supply to AC mains before loading the system with power.

The JNP10K-PWR-AC2 requires the enhanced power bus to operate at full power. You can use the standard bus, but available power is 3000 W for power budget from the power management software. To determine whether your system has the standard power bus or the enhanced power bus, see "[QFX10000 Status Panel](#)" on page 25.

## JNP10K-PWR-AC2 Power Specifications

The JNP10K-PWR-AC2 power supply supports AC, HVAC, and HVDC.

[Table 15 on page 51](#) lists the power specifications for the JNP10K-PWR-AC power supply.

**Table 15: Power Specifications for a JNP10K-PWR-AC2 Power Supply**

Item	Specifications
AC input voltage	180–305 VAC
DC input voltage	190–410 VDC
Input current rating	28.5 A
DC output power	12.3 V, 5500 W with dual feed and 5000 W with single feed

[Table 16 on page 51](#) shows the physical specifications for a JNP10K-PWR-AC2 power supply.

**Table 16: Physical Specifications for a JNP10K-PWR-AC2 Power Supply**

Specification	Value
Height	3.5 in. (8.89 cm)
Width	3.6 in. (9.14 cm)
Depth	15.1 in. (38.35 cm)
Weight	11.4 lb (5.17 kg)

## QFX10000 Power Cables Specifications

### IN THIS SECTION

- [QFX10000-PWR-AC Power Cable Specifications | 53](#)
- [JNP10K-PWR-AC2 Power Cable Specifications | 55](#)
- [JNP10K-PWR-AC2 Power Cable Specifications for 30-A Input | 58](#)

Most sites distribute power through a main conduit that leads to frame-mounted power distribution panels, one of which can be located at the top of the rack that houses the switch. An AC power cord connects each power supply to the power distribution panel.

Each detachable AC power cord is 8 feet (approximately 2.5 meters) long. The coupler end of the appliance cord inserts into the AC appliance inlet on the faceplate of the AC power supply. The coupler type is C19 as described by the International Electrotechnical Commission (IEC) standard 60320. The plug end of the power cord fits into the power source outlet that is standard for your geographical location.

**NOTE:** In North America, AC power cords must not exceed 15 feet (approximately 4.5 meters) in length, to comply with National Electrical Code (NEC) Sections 400-8 (NFPA 75, 5-2.2) and 210-52 and Canadian Electrical Code (CEC) Section 4-010(3). The cords shipped with the switch to North America and Canada are in compliance.

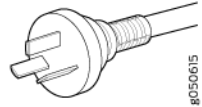
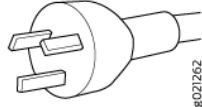

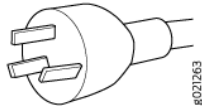
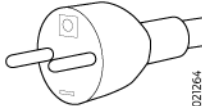

QFX10000 AC, high-voltage alternating current (HVAC), and high-voltage direct current (HVDC) have specific cord requirements. Use the following sections to determine the cable requirements based on the model of your power supply and any mode settings:

- QFX10000-PWR-AC see "[QFX10000-PWR-AC Power Cable Specifications](#)" on page 53
- JNP10K-PWR-AC2 with 20-A input, see "[JNP10K-PWR-AC2 Power Cable Specifications](#)" on page 55
- JNP10K-PWR-AC2 with 30-A input, see "[JNP10K-PWR-AC2 Power Cable Specifications for 30-A Input](#)" on page 58

## QFX10000-PWR-AC Power Cable Specifications

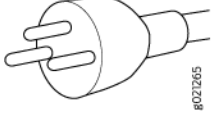

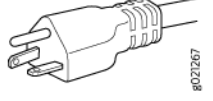
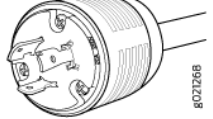
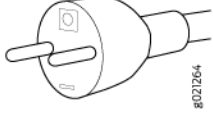
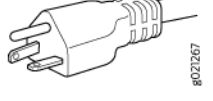

Table 17 on page 53 lists the AC power cord specifications for QFX10000-PWR-AC for various countries and regions.

**Table 17: AC Power Cord Specifications for QFX10000-PWR-AC Power Supplies**

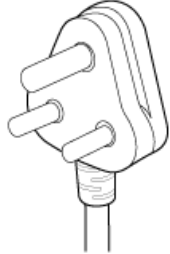


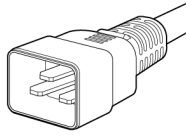
Country/Region	Electrical Specifications	Plug Standards	Juniper Model Number	Graphic
Argentina	250 VAC, 16 A, 50 Hz	IRAM Type RA/3/20	CBL-EX-PWR-C19-AR	
Australia	250 VAC, 15 A, 50 Hz	AS/NZS 3112 Type SAA/3/15	CBL-EX-PWR-C19-AU	
Brazil	250 VAC, 16 A, 50 Hz	NBR 14136: 2002 Type BR/3/20	CBL-EX-PWR-C19-BR	
China	250 VAC, 16 A, 50 Hz	GB 1002 Type PRC/3/16	CBL-EX-PWR-C19-CH	
Europe (except Italy, Switzerland, and United Kingdom)	250 VAC, 16 A, 50 Hz	CEE (7) VII Type VIIG	CBL-EX-PWR-C19-EU	
India	250 AC, 16 A, 50 Hz	SABS 164/1:1992 Type ZA/3	CBL-EX-PWR-C19-SA	



**Table 17: AC Power Cord Specifications for QFX10000-PWR-AC Power Supplies (Continued)**

Country/Region	Electrical Specifications	Plug Standards	Juniper Model Number	Graphic
Israel	250 AC, 16 A, 50 Hz	SI 32/1971 Type IL/3	CBL-EX-PWR-C19-IL	 #021265
Italy	250 VAC, 16 A, 50 Hz	CEI 23-16 Type I/3/16	CBL-EX-PWR-C19-IT	 #021266
Japan	250 VAC, 16 A, 60 Hz	NEMA 6-20 Type N6/20	CBL-EX-PWR-C19-JP (default)	 #021267
	250 VAC, 16 A, 60 Hz	NEMA L6-20P Type NEMA Locking	CBL-EX-PWR-C19-JPL	 #021268
Korea	250 VAC, 16 A, 50 Hz	CEE (7) VII Type VIIG	CBL-EX-PWR-C19-KR	 #021264
North America	250 VAC, 16 A, 60 Hz	NEMA 6-20 Type N6/20	CBL-EX-PWR-C19-US (default)	 #021267
	250 VAC, 16 A, 60 Hz	NEMA L6-20P Type NEMA Locking	CBL-EX-PWR-C19-USL	 #021268

**Table 17: AC Power Cord Specifications for QFX10000-PWR-AC Power Supplies (Continued)**

Country/Region	Electrical Specifications	Plug Standards	Juniper Model Number	Graphic
South Africa	250 VAC, 16 A, 50 Hz	SABS 164/1:1992 Type ZA/3	CBL-EX-PWR-C19-SA	 g021289
Switzerland	250 VAC, 16 A, 50 Hz	SEV 5934/2 Type 23G	CBL-EX-PWR-C19-SZ	 g050617
United Kingdom	250 VAC, 13 A, 50 Hz	BS 1363/A Type BS89/13	CBL-EX-PWR-C19-UK	 g021271
Worldwide (except Japan)	250 VAC, 16 A, 50 Hz	EN 60320-2-2/1	CBL-EX-PWR-C19-C20	 g050751

## JNP10K-PWR-AC2 Power Cable Specifications

The JNP10K-PWR-AC2 power supply operates in two modes:

- 30-A input with 5500 W output

"[JNP10K-PWR-AC2 Power Cable Specifications for 30-A Input](#)" on page 58 shows the cables and connectors for 30-A input.

- 20-A input with 3000 W output

[Table 18](#) on page 56 shows the cables appropriate for 20-A input.

- HVAC input with 3000 W output

Table 19 on page 58 shows the cable appropriate for HVAC input.



**WARNING:** Do not run JNP10K-PWR-AC2 power supplies using 20-A cables if connected to 30-A input.

**Table 18: JNP10K-PWR-AC2 Power Cable Specifications for 20-A Input**

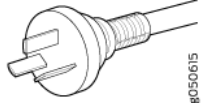
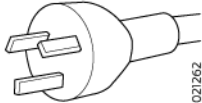

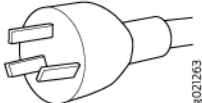
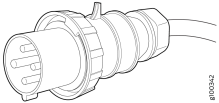


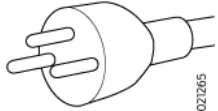

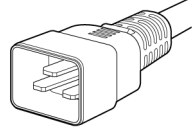
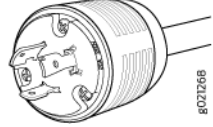
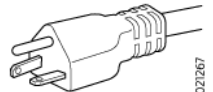
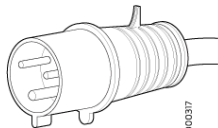
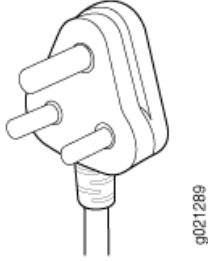

Locale	Cord Set Rating	Plug Standards	Spare Juniper Model Number	Graphic
Argentina	16 A, 250 VAC	IRAM 2073 Type RA/3	CBL-JNP-SG4-AR	
Australia and New Zealand	15 A, 250 VAC	AS/NZS 4417	CBL-JNP-SG4-AU	
Brazil	16 A, 250 VAC	NBR 14136 Type BR/3	CBL-JNP-SG4-BR	
China	16 A, 250 VAC	GB2099	CBL-JNP-SG4-CH	
Europe (except Italy, Switzerland, and United Kingdom)	20 A, 250 VAC	IEC 316P6W	CG_CBL-APP-400-02	
Great Britain	13 A, 250 VAC,	BS1363	CBL-JNP-SG4-UK	

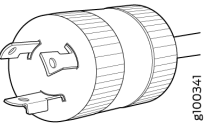
Table 18: JNP10K-PWR-AC2 Power Cable Specifications for 20-A Input (Continued)

Locale	Cord Set Rating	Plug Standards	Spare Juniper Model Number	Graphic
India	16 A, 250 VAC	SANS 164/1	CBL-JNP-SG4-SA	 #021270
Israel	16 A, RA, 250 VAC	SI 32/1971 Type IL/3G	CBL-JNP-SG4-IL	 #021265
Italy	16 A, 250 VAC	CEI 23-16	CBL-JNP-SG4-IT	 #021266
North America	20 A, 250 VAC	C20 to Anderson 3-5958p4	CBL-JNP-SG4-C20	 #050751
North America	16 A, 250 VAC	Locking NEMA L6-20P	CBL-JNP-SG4-US-L	 #021268
North America	16 A, 250 VAC	NEMA 6-20P	CBL-JNP-SG4-US	 #021267
North America	20 A, 250 V	IEC 320P6W	CG_CBL-APP-400-02	 #000317

**Table 18: JNP10K-PWR-AC2 Power Cable Specifications for 20-A Input (Continued)**

Locale	Cord Set Rating	Plug Standards	Spare Juniper Model Number	Graphic
South Africa	16 A, 250 VAC	SANS 164/1	CBL-JNP-SG4-SA	 #021289
Switzerland	16 A, 250 VAC	CEI 23-50	CBL-JNP-SG4-SZ	 #02266

**Table 19: JNP10K-PWR-AC2 Power Cable Specifications for HVAC Input**

Locale	Cord Set Rating	Plug Standards	Spare Juniper Model Number	Graphic
North America	16 A, 277 V	NEMA L7-20P	CBL-JNP-SG4-HVAC	 #100341

### JNP10K-PWR-AC2 Power Cable Specifications for 30-A Input

The JNP10K-PWR-AC2 HVAC or HVDC power supplies requires a high voltage cable assembly when set for 30-A input. One end of the cable has an Anderson APP-400 connector, the other end of the cable is bare wire. See [Figure 28 on page 59](#) and [Table 20 on page 59](#). These cables are separately orderable and are not shipped automatically with JNP10K-PWR-AC2 orders. An example of the right-angle cable and connector is shown in [Figure 30 on page 60](#).

For connection to AC systems, Juniper provides a cable with either a NEMA 30-A connector ([Figure 28 on page 59](#)) or an IEC 330P6W connector ([Figure 29 on page 59](#)).

Figure 28: NEMA 30-A Connector

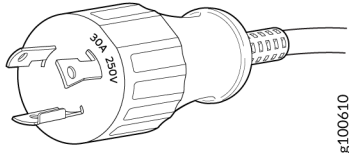


Figure 29: IEC 330P6W Connector

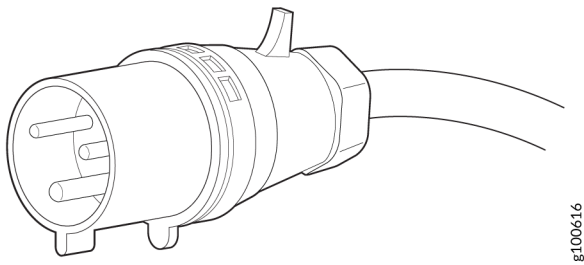


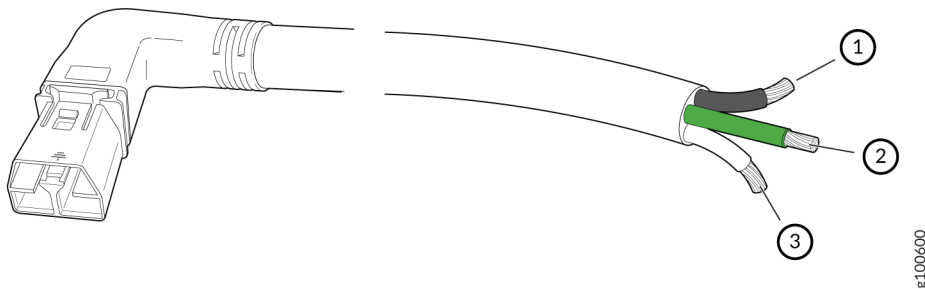
Table 20: 30-A Cabling Options

Power Cord	Locale	Cord Set Rating	Plug Standards	Connector	Spare Juniper Model Number
HVDC power cord	Any	30- A, 400 VAC	UL 950 and IEC 60950	Anderson/straight to bare wire	CBL-PWR2-BARE
HVDC power cord	Any	30-A, 400 VAC	UL 950 and IEC 60950	Anderson/right-angle to bare wire	CBL-PWR2-BARE-RA
AC power cord	Continental Europe	30-A 250 VAC	UL 950 and IEC332P6	Anderson/straight to IEC 332P6	CBL-PWR2-332P6W-RA
AC power cord	North America	30-A 250 VAC	UL 950 and IEC332P6	Anderson/straight to IEC332P6	CBL-PWR2-332P6W

**Table 20: 30-A Cabling Options (Continued)**

Power Cord	Locale	Cord Set Rating	Plug Standards	Connector	Spare Juniper Model Number
AC power cord	North America	30-A 240 VAC	IEC330P6	Anderson/right-angle to IEC 330P6	CBL-PWR2-330P6W-RA
AC power cord	North America	30-A 240 VAC	IEC330P6	Anderson/straight to IEC 330P6	CBL-PWR2-330P6W
AC power cord	North America	30-A 250 VAC	UL 498, IEC5958P4	Anderson/straight to L6-30P	CBL-PWR2-L6-30P
AC jumper power cord	North America	30-A 400 VAC	UL, CSA	Anderson/straight to Anderson	CG-CBL-APP-400-02
AC power cord	North America	30-A 250 VAC	UL 498, CSA	Anderson/right-angle to L6-30P	CBL-PWR2-L6-30P-RA

**Figure 30: Right-Angle, Bare Cable with Anderson Connector**



1– Black wire–Return (+)

3– White wire–Neutral

2– Green wire–Ground

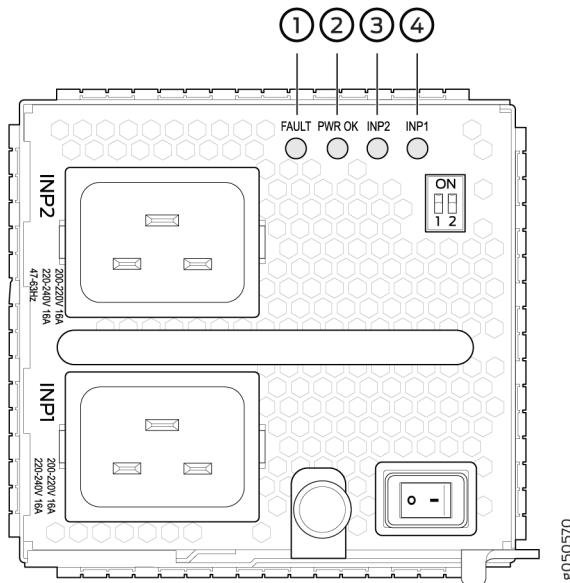
## SEE ALSO

*General Electrical Safety Guidelines and Warnings*

## QFX10000 AC Power Supply LEDs

The QFX10000-PWR-AC power supply has four LEDs on its faceplate: **INP1**, **INP2**, **PWR OK**, and **FAULT**. These LEDs display information about the status of the power supply. See [Figure 31 on page 61](#).

**Figure 31: LEDs on a QFX10000-PWR-AC, Power Supply in QFX10000 Switches**



1– **FAULT**

2– **PWR OK**

3– **INP2**–Source input 2

4– **INP1**–Source input 1

[Table 21 on page 62](#) describes the LEDs on a QFX10000-AC power supply in QFX10008 and QFX10016 modular chassis.



Table 21: LEDs on a QFX10000-AC Power Supply in a QFX10000

LED	Color	State	Description
<b>INP1</b> (INP0 in CLI output) or <b>INP2</b> (INP1 in CLI output)	Yellow	Blinking	Indicates that the AC power input voltage is not within normal operating range.
	Green	Solid	AC is within operating range (200–240 VAC).
	Dark	Unlit	The power supply is switched off.
<b>PWR OK</b>	Green	Solid	DC power output is within normal operating range.
	Yellow	Blinking	The output is out of the limits.
<b>FAULT</b>	Dark	Unlit	Power supply is functioning normally.
	Red	Solid	Power supply has failed and must be replaced. Or, only one input is powered and the enabled switch for the input that is not powered is set to <b>ON</b> . See <a href="#">"Connect AC Power to a QFX Modular Chassis" on page 217</a> for more information about the enable switches.

**NOTE:** If the **INP1** or **INP2** LED and the **PWR OK** LED are unlit, the AC power cord is not installed properly or the power supply has failed.

If the **INP1** or **INP2** LED is lit and the **PWR OK** LED is unlit, the AC power supply is not installed properly or the power supply has an internal failure.

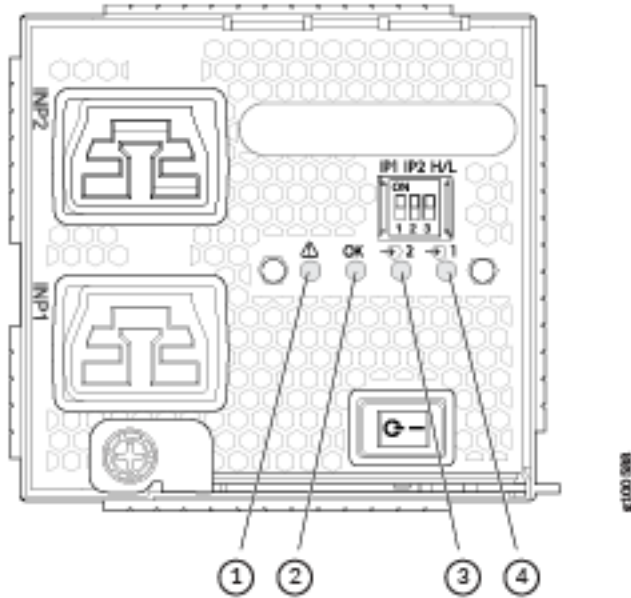
## SEE ALSO

[Power Requirements for QFX10000 Components](#) | 163

## JNP10K-PWR-AC2 Power Supply LEDs

The JNP10K-PWR-AC2 power supply has four LEDs on its faceplate: **!**, **OK**, **2**, and **1**. These LEDs display information about the status of the power supply. See [Figure 32 on page 63](#).

Figure 32: LEDs on a JNP10K-PWR-AC2 HVAC/HVDC Power Supply



1– **!** FAULT

2– **OK** PWR OK

3– **2** INP2–Source input 1

4– **1** INP1–Source input 0

**NOTE:** Physical markings on the power supply are INP1 and INP2. These markings correspond to INP0 and INP1 in the `show chassis power` output (see [Table 22 on page 63](#)).

Table 22: Physical Markings on Chassis Versus Show Chassis Power Command

Physical Marking on JNP10K-PWR-AC2	Show Chassis Power Command
INP1	INP0
INP2	INP1

Table 23 on page 64 describes the LEDs on a JNP10K-PWR-AC2 power supply.

**Table 23: Interpreting JNP10K-PWR-AC2 LEDs**

LED	Color	State	Description
<b>INP1</b> or INP0 in CLI output	Yellow	Blinking	The input voltage is present, but is not within normal operating range.
	Green	Solid	The input voltage is present and within normal operating range.
	Unlit	Off	The power supply is switched off; voltage is zero.
<b>INP2</b> or INP1 in CLI output	Yellow	Blinking	The input voltage is present, but is not within normal operating range.
	Green	Solid	The input voltage is present and within normal operating range.
	Unlit	Off	The power supply is switched off; voltage is zero.
<b>OK</b>	Green	Solid	The power supply output is within normal operating range.
	Yellow	Blinking	The power supply output is out of the power limits or is over-current position.
<b>!</b>	Red	Solid	Power supply has failed and must be replaced.
	Unlit	Off	Power supply is functioning normally.

## RELATED DOCUMENTATION

[Maintaining QFX10000 Power System | 243](#)

[Connect AC Power to a QFX Modular Chassis | 217](#)

# QFX10000 DC Power System

## IN THIS SECTION

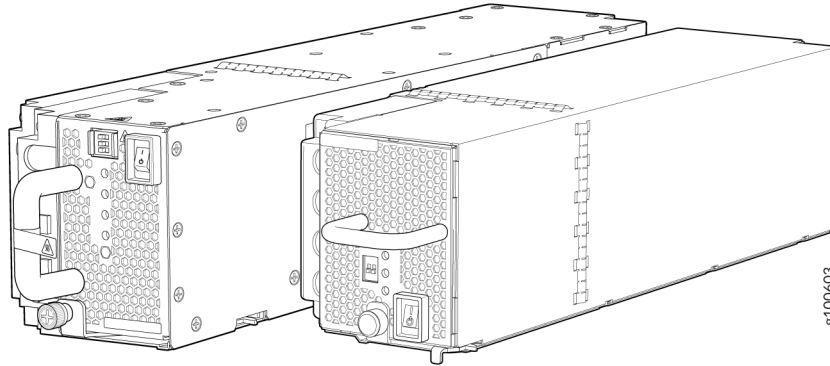
- [QFX10000-PWR-DC Power Supply | 66](#)
- [QFX10000-PWR-DC Power Specifications | 69](#)
- [JNP10K-PWR-DC2 Power Supply | 70](#)
- [JNP10K-PWR-DC2 Power Specifications | 72](#)
- [QFX10000-PWR-DC Power Supply LEDs | 73](#)
- [JNP10K-PWR-DC2 Power Supply LEDs | 75](#)

The QFX10000 supports three types of DC power supply modules:

- QFX10000-PWR-DC—A 2500-W, 12-VDC dual power supply.
- JNP10K-PWR-DC2—A 5500-W, 12-VDC quad input power supply. For details on this power supply, see "[JNP10K-PWR-DC2 Power Supply](#)" on page 70.
- JNP10K-PWR-AC2—An AC, high-voltage alternating current (HVAC,) or high-voltage direct current (HVDC) power supply. In high power mode, this power supply provides 12.3 V, 5000 W with a single feed and 5500 W with dual feeds. For details on this power supply, see "[JNP10K-PWR-AC2 Power Supply](#)" on page 48.

All three power supplies fit into a power slot bay, but the JNP10K-PWR-AC2 and JNP10K-PWR-DC2 are longer and protrude from the bay when fully inserted into the chassis. See [Figure 33](#) on page 66.

Figure 33: Size Comparison Between QFX10000-PWR-DC and JNP10K-PWR-DC2 Power Supplies



## QFX10000-PWR-DC Power Supply



**CAUTION:** Do not mix power supply models in the same chassis in a running environment. DC and HVDC can coexist in the same chassis during the hot swap of DC for HVDC.

The QFX10000-PWR-DC power supply is a 2500-W, 12-VDC, dual input power supply. The output of each QFX10000-PWR-DC power supply is 12-VDC. The output power is 2500 W.



**WARNING:** The switch is pluggable type A equipment installed in a restricted-access location. It has a separate protective earthing terminal on the chassis that must be connected to earth ground permanently to ground the chassis adequately and protect the operator from electrical hazards.



**CAUTION:** Before you begin installing the switch, ensure that a licensed electrician has attached an appropriate grounding lug to the grounding cable that you supply. Using a grounding cable with an incorrectly attached lug can damage the switch.

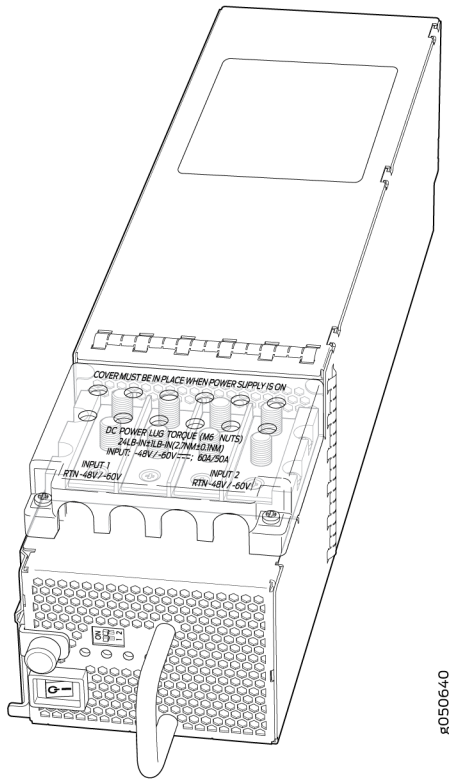
**NOTE:** QFX10000-PWR-DC power supplies are shipped only in the redundant configuration of QFX10000 switches. For details about different chassis configurations, see "[QFX10008 Configurations and Upgrade Options](#)" on page 14 and [QFX10016 Components and Configurations](#).

Each QFX10000-PWR-DC power supply weighs approximately 6 lb (2.7 kg) and has two independent pairs of DC input lugs (**Input 1, RTN, -48V/-60V** and **Input 2, RTN, -48V/-60V**) on the faceplate of the power supply. Each inlet requires a dedicated DC power feed. Although each inlet provides sufficient input power to provide full output, always connect to a dedicated DC power feed to provide redundancy. Only one power feed is operational at a time.

DC power models employ electronic A-B input selection. It provides  $2n$  source redundancy and  $n+1$  power supply redundancy using fewer power supplies than you would require in a  $2n$  configuration. Should one power source fail, electronic A-B input selection switches the power supply to the alternate source.

Each QFX10000-PWR-DC power supply has a power switch with international markings for on (I) and off (O), a fan, and four LEDs on the faceplate that indicate the status of the power supply. See [Figure 34 on page 68](#).

Figure 34: QFX10000-PWR-DC Power Supply



**NOTE:** The QFX10000-PWR-DC power supply requires a dedicated circuit breaker for each input DC feed. The chosen breaker should be sized to deliver 60 A of input current.

Each power supply connects to the combined power rail in a QFX10008 or QFX10016. The power rail distributes the output power produced by the power supplies to different switch components. Each QFX10000-PWR-DC power supply provides power to all the components in the switch.

**NOTE:** Ensure that the power cables do not block access to router components or drape where people can trip on them. Always prevent cables from being exposed to hot air exhaust by routing them away from the fan trays and power supplies at the rear of the chassis.

A DC power supply can operate with only one input DC feed connected. The RCB only enables the components for which sufficient power is available.

The JNP10K-PWR-DC power supplies do not share power.

QFX10000-PWR-DC power supplies can use the standard bus or the enhanced bus.

Each QFX10000-PWR-DC power supply has its own fan and is cooled by its own internal cooling system. The airflow is from the front of the power supply to the back. Hot air exhausts from the rear of the chassis.

## QFX10000-PWR-DC Power Specifications

QFX10000-PWR-DC power supplies are supported in only the QFX10008 and QFX10016 redundant configuration. [Table 24 on page 69](#) lists the power specifications for the QFX10000-PWR-DC power supply used in a QFX10000 modular chassis.

**Table 24: Power Specifications for the QFX10000-PWR-DC Power Supply**

Item	Specifications
DC input voltage	<ul style="list-style-type: none"> <li>• Minimum operating voltage: -40 VDC</li> <li>• Nominal operating voltage: -48 VDC</li> <li>• Operating voltage range: -40 VDC through -72 VDC</li> </ul>
DC input current rating	60 A maximum at nominal operating voltage (-48 VDC) for each input terminal
Output power	2500 W

[Table 25 on page 69](#) shows the physical specifications for a QFX10000-PWR-DC power supply.

**Table 25: Physical Specifications of a QFX10000-PWR-DC Power Supply**

Specification	Value
Height	3.5 in. (8.89 cm)
Width	3.6 in. (9.14 cm)
Depth	14.4 in. (36.58 cm)



**Table 25: Physical Specifications of a QFX10000-PWR-DC Power Supply (Continued)**

Specification	Value
Weight	6 lb (2.72 kg)

## JNP10K-PWR-DC2 Power Supply

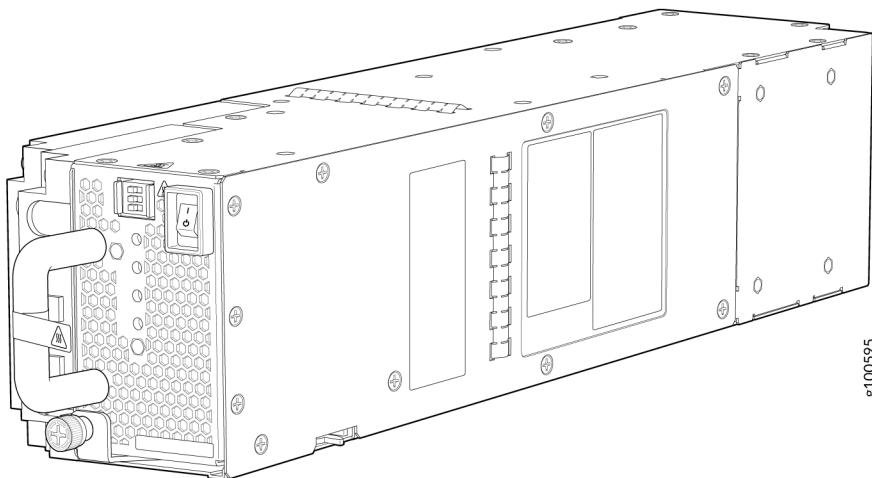
The JNP10K-PWR-DC2 power supply provides two power supplies in a single housing that accepts either 60 A or 80 A using four redundant input power feeds. PS\_0 and PS\_1 each have redundant input feeds: A0 and/or B0 for PS\_0 and A1 and/or B1 for PS\_1. The input is configured using a set of DIP switches on the power supply faceplate. The output is dependant on the settings of these DIP switches. See [Table 26 on page 70](#). See [Figure 35 on page 71](#).

The JNP10K-PWR-DC2 power supplies share power.

**Table 26: Power Input and Output Voltages for JNP10K-PWR-DC2 Power Supplies**

INP0 (Switch 1)	INP1 (Switch 2)	H/L (High Input 80 A/Low Input 60A)	Output Power
On	On	On (80 A)	5500 W
On	On	Off (60 A)	4400 W
On	Off	On (80 A)	2750 W
Off	On	On (80 A)	2750 W
On	Off	Off (60 A)	2200 W
Off	On	Off (60 A)	2200 W

Figure 35: JNP10K-PWR-DC2 Power Supply



**CAUTION:** Do not mix power supply models in the same chassis in a running environment. JNP10K-PWR-DC and JNP10K-PWR-DC2 can coexist in the same chassis during power supply upgrades.



**WARNING:** The router is pluggable type A equipment installed in a restricted-access location. It has a separate protective earthing terminal on the chassis that must be connected to earth ground permanently to ground the chassis adequately and protect the operator from electrical hazards.



**CAUTION:** Before you begin installing the router, ensure that a licensed electrician has attached an appropriate grounding lug to the grounding cable that you supply. Using a grounding cable with an incorrectly attached lug can damage the router.

**NOTE:** DC power supplies are shipped only in the redundant configuration of QFX10000 switches. For details about different chassis configurations, see "[QFX10008 Configurations and Upgrade Options](#)" on page 14 and [QFX10016 Components and Configurations](#).

Chassis with the enhanced bus support the full 5500 W available from the JNP10K-PWR-DC2. Chassis with the standard bus provides 3000 W for power budget from the power management software. To determine whether your system has the standard power bus or the enhanced power bus, see "[QFX10000 Status Panel](#)" on page 25.

## JNP10K-PWR-DC2 Power Specifications

Table 27 on page 72 lists the power specifications for the JNP10K-PWR-DC2 power supply used in a QFX10000 chassis.

**Table 27: Power Specifications for the JNP10K-PWR-DC2 Power Supply**

Item	Specifications
DC input voltage	<ul style="list-style-type: none"> <li>• Minimum operating voltage: -40 VDC</li> <li>• Nominal operating voltage: -48 VDC</li> <li>• Operating voltage range: -40 VDC through -72 VDC</li> </ul>
DC input current rating	<ul style="list-style-type: none"> <li>• 76-A maximum at minimum operating voltage (-40 VDC) with 80-A dip switch setting and 5500 W output load.</li> <li>• 64-A maximum at nominal operating voltage (-48 VDC) with 80-A dip switch setting and 5500 W output load.</li> <li>• 60-A maximum at minimum operating voltage (-40 VDC) with 60-A dip switch setting and 4400 W output load.</li> <li>• 50-A maximum at nominal operating voltage (-48 VDC) with 60-A dip switch setting and 4400 W output load.</li> </ul>
Output power	<p>2200 W for low input (60-A) single feed</p> <p>4400 W for low input (60-A) dual feed</p> <p>2750 W for high input (80-A) single feed</p> <p>5500 W for high input (80-A) dual feed</p>

Table 28 on page 72 shows the physical specifications for a JNP10K-PWR-DC2 power supply.

**Table 28: Physical Specifications of a JNP10K-PWR-DC2 Power Supply**

Specification	Value
Height	3.5 in. (8.89 cm)

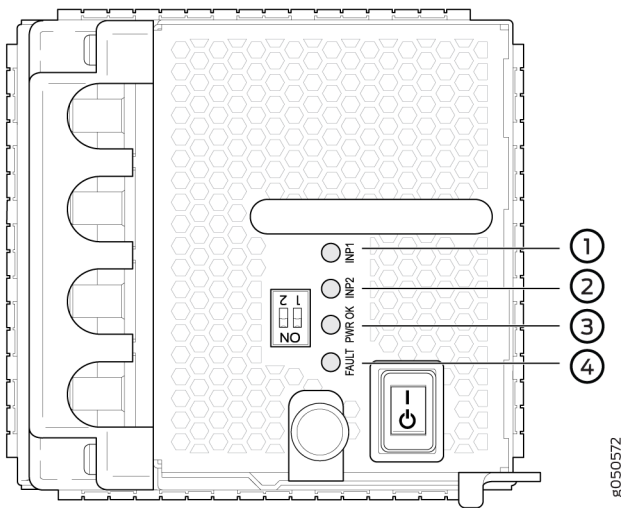
**Table 28: Physical Specifications of a JNP10K-PWR-DC2 Power Supply (Continued)**

Specification	Value
Width	3.6 in. (1.63 cm)
Depth	16.05 in. (40.77 cm)
Weight	8.1 lb (3.67 kg)

## QFX10000-PWR-DC Power Supply LEDs

A QFX10000-PWR-DC power supply has four LEDs on its faceplate: **INP1**, **INP2**, **PWR OK**, and **FAULT**. These LEDs display information about the status of the power supply. See [Figure 36 on page 73](#).

**Figure 36: LEDs on a QFX10000-PWR-DC Power Supply in QFX10000 Switches**



1– INP1–Source input 1

3– PWR OK

2– INP2–Source input 2

4– FAULT

[Table 29 on page 74](#) describes the LEDs in QFX10008 and QFX10016 modular chassis.

Table 29: LEDs on an QFX10000-PWR-DC Power Supply in QFX10000

LED	Color	State	Description
1 (INP0 in CLI output) or 2 (INP1 in CLI output)	Yellow	Blinking	Indicates the DC power input voltage is not within normal operating range.
	Green	Solid	DC power is within operating range (-40 VDC to -72 VDC).
	Unlit	Off	The power supply is switched off.
PWR OK	Green	Solid	DC power output is within normal operating range.
	Yellow	Blinking	The output is out of the limits.
FAULT	Red	Solid	Power supply has failed and must be replaced.
	Unlit	Off	Power supply is functioning normally. Or, only one input is powered and the enable switch for the input that is not powered is set to <b>ON</b> . See <a href="#">"Connect DC Power to a QFX10008 or QFX10016" on page 217</a> for more information on the enable switches.

**NOTE:** If the **INP1** or **INP2** and the **PWR OK** LED are unlit, the power cords are not installed properly or the power supply has failed.

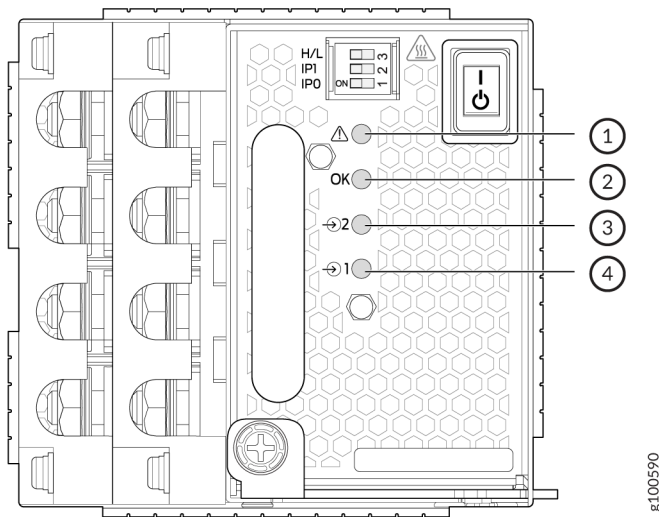
If the **INP1** or **INP2** LED is lit green and the **PWR OK** LED is unlit, the power supply is not installed properly or the power supply has an internal failure.

If the **FAULT** LED is blinking, add a power supply to balance the power demand and supply.

## JNP10K-PWR-DC2 Power Supply LEDs

A JNP10K-PWR-DC2 power supply module has four LEDs on its faceplate: **1**, **2**, **OK**, and the symbol for fault, **!**. These LEDs display information about the status of the power supply. See [Figure 37 on page 75](#).

**Figure 37: LEDs on a JNP10K-PWR-DC2 Power Supply**



1– !-FAULT

3– 2-Source input 1

2– OK-Power okay

4– 1-Source input 0

[Table 30 on page 75](#) describes the LEDs on a JNP10K-PWR-DC2 power supply.

**Table 30: LEDs on a JNP10K-PWR-DC2 Power Supply**

LED	Color	State	Description
1 (INP0 in CLI output) or 2 (INP1 in CLI output)	Yellow	Blinking	Indicates the DC power input voltage is not within normal operating range.
	Green	Solid	DC power is within operating range (-40 VDC to -72 VDC).
	Unlit	Off	The power supply is switched off.

Table 30: LEDs on a JNP10K-PWR-DC2 Power Supply (Continued)

LED	Color	State	Description
OK	Green	Solid	DC power output is within normal operating range.
	Yellow	Blinking	The output is out of the limits.
!	Red	Solid	Power supply has failed and must be replaced.
	Unlit	Off	Power supply is functioning normally. Or, only one input is powered and the enable switch for the input that is not powered is set to <b>ON</b> . See <a href="#">"Connecting the QFX10008 or QFX10016 to Power" on page 213</a> for more information on the enable switches.

**NOTE:** If the **1** or **2** and the **OK** LED are unlit, the power cables are not installed properly or the power supply has failed.

If the **1** or LED is lit green and the **OK** LED is unlit, the power supply is not installed properly or the power supply has an internal failure.

If the **!** LED is blinking, add a power supply to balance the power demand and supply.

## RELATED DOCUMENTATION

[Maintaining QFX10000 Power System | 243](#)

[Power Requirements for QFX10000 Components | 163](#)

[Connect DC Power to a QFX10008 or QFX10016 | 217](#)

# QFX10008 Switch Interface Board

## IN THIS SECTION

- [QFX10008 Switch Interface Board Description | 77](#)
- [QFX10000 Switch Interface Board LEDs | 79](#)

## QFX10008 Switch Interface Board Description

Switch Interface Boards (SIBs) create the switch fabric for the QFX10008. Each QFX10008 contains six SIBs that are installed vertically, mid-chassis, between the line cards and the RCBs in the front and the fan trays in the rear. When all six SIBs are installed, the QFX10008 has a net switching capacity of 42 terabits per second (Tbps).

The SIBs make up the QFX10008 switching plane. Five SIBs are required for operation with the sixth providing  $n+1$  redundancy. Each SIB has eight connectors that match and connect to a connector on one of the eight line cards. SIB slots are numbered 0 to 5, numbered from left to right. See [Figure 38 on page 78](#).



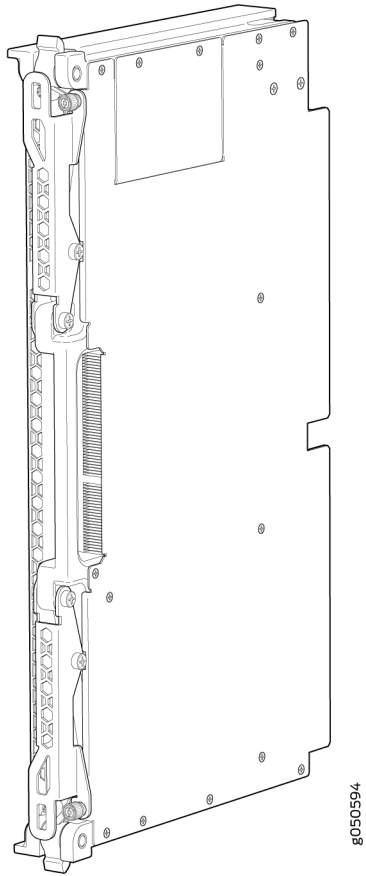
**Figure 38: SIB**

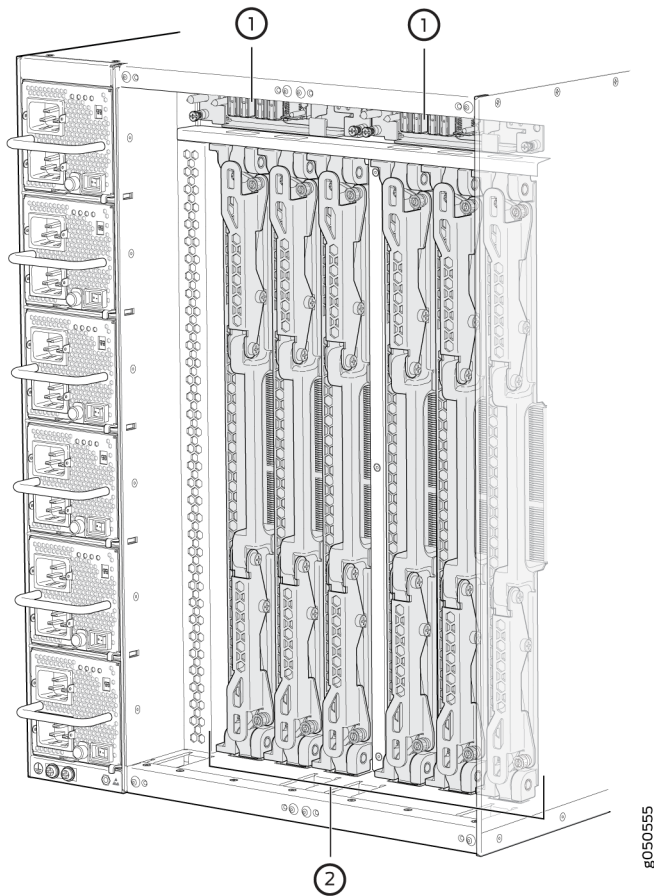
Table 31 on page 78 shows the physical specifications for a QFX10008 SIB.

**Table 31: Dimensions of a QFX10008 SIB**

Specification	Value
Height	19.7 in. (50.04 cm)
Width	1.8 in. (4.57 cm)
Depth	10.4 in. (26.42 cm)
Weight	14.8 lb (6.71 kg)

SIBs are hot-removable and hot-insertable field-replaceable units (FRUs). They are not visible from the outside of the switch chassis. You must remove one of the fan trays in order to view the SIBs. The SIBs are numbered from left to right **SIB0** to **SIB5**. See [Figure 39 on page 79](#).

**Figure 39: SIBs Installed in a QFX10008**



1– Fan tray controllers

2– SIBs

## QFX10000 Switch Interface Board LEDs

The Switch Interface Board (SIB) has two status LEDs at the top of each board. See [Figure 40 on page 80](#).

Figure 40: SIB LEDs

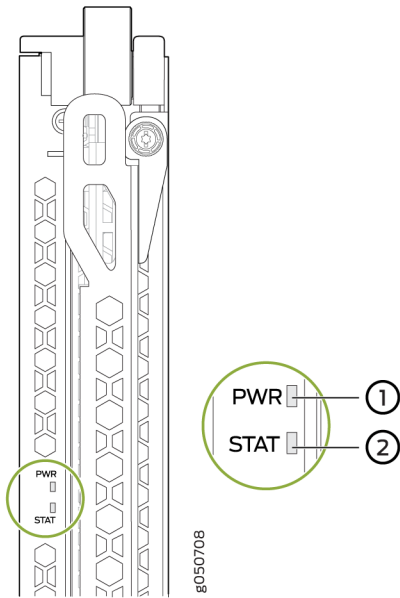


Table 32 on page 80 describes the functions of these LEDs.

Table 32: SIB LEDs

Label	Color	State	Description
<b>PWR</b>	Green	On steadily	The SIB is receiving power.
	Yellow	Blinking	Power fault.
	Unlit	Off	The SIB is either offline or not receiving power.
<b>STAT</b>	Green	On steadily	The SIB is online and functioning normally.
	Green	Blinking	The beacon feature is enabled.
	Yellow	On steadily	The SIB has failed.
	Unlit	Off	The fan tray controller is having a power problem.

## RELATED DOCUMENTATION

[Handling and Storing QFX10000 Line Cards, RCBs, and SIBs | 226](#)

[Maintaining QFX10000 Switch Interface Boards | 298](#)

# QFX10000 Routing and Control Board

## IN THIS SECTION

- [QFX10000 Routing and Control Board Description | 81](#)
- [QFX10000 Routing and Control Board LEDs | 83](#)

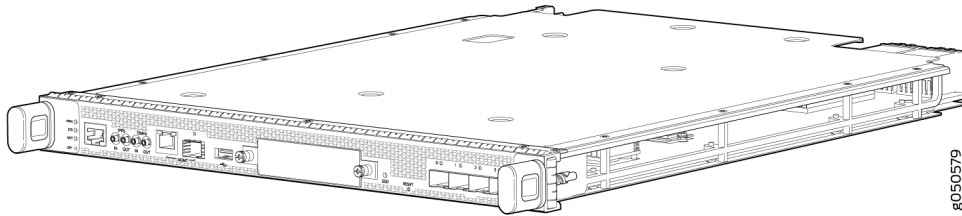
## QFX10000 Routing and Control Board Description

### IN THIS SECTION

- [RCB Functions | 82](#)
- [RCB Components | 82](#)

The Routing and Control Board (RCB) is responsible for system management in a QFX10008 or QFX10016 (see [Figure 41 on page 82](#)). The switch chassis can run with one or two RCBs. The base configurations ship with one RCB that can be expanded with a second RCB for a fully-redundant system. When two RCBs are installed, one functions as the primary and the second as a backup. If the primary RCB is removed, the backup restarts and becomes the primary.

**Figure 41: QFX10000 RCB**



This topic covers:

## **RCB Functions**

The RCB integrates the control plane and Routing Engine functions into a single management unit. Each RCB provides all the functions needed to manage the operation of the modular chassis:

- System control functions such as environmental monitoring
- Routing Layer 2 and Layer 3 protocols
- Communication to all components such as line cards, Switch Interface Boards (SIBs), and power and cooling
- Transparent clocking
- Alarm and logging functions

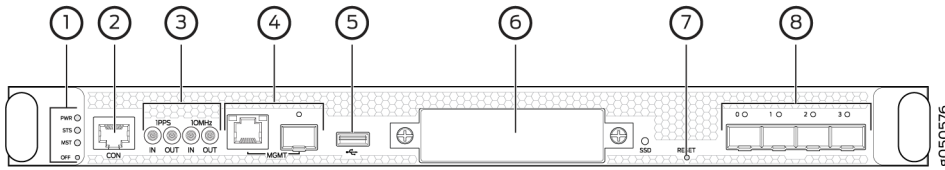
## **RCB Components**

Each RCB consists of the following internal components:

- Quad-core 2.5 GHz CPU
- 32 GB SDRAM
- 50 GB or 100 GB onboard SATA SSD

Other standard interfaces are shown in [Figure 42 on page 83](#).

Figure 42: RCB Faceplate



1– RCB status LEDs	5– USB 2.0 port
2– Console port	6– SATA SSD slot
3– PTP-capable connections: SMB In, SMB Out, 10 MHz In, 10 MHz Out	7– Reset button
4– Ethernet management ports: RJ-45 for 10/100/1000 BASE-T (em0) and small-form factor pluggable (SFP) for fiber (em1). If both copper and fiber cables are installed, the RJ-45 is the default.	8– Four SFP+ ports (reserved for future use)

**NOTE:** You can use either management interface, em0 or em1 when the RCB is running as the primary RE. Use only em1 when the RCB is running as the backup RE.

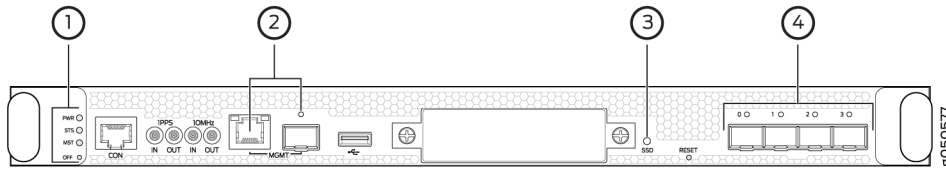
## QFX10000 Routing and Control Board LEDs

### IN THIS SECTION

- RCB Status Panel LEDs | 84
- QFX10000 Management Port LEDs | 85
- SATA SSD LEDs | 87
- Virtual Port Connections | 87

The QFX10000 Routing and Control Boards (RCBs) have four types of LED indicators (see [Figure 43 on page 84](#)).

Figure 43: QFX10000 RCB LEDs

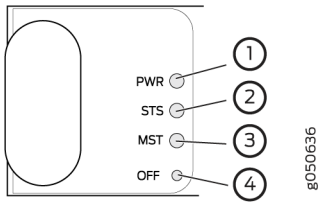


1– RCB status panel	3– SATA SSD
2– Management ports	4– Virtual port connection

### RCB Status Panel LEDs

The RCB status panel LEDs indicate the state of the RCB (see [Figure 44 on page 84](#)).

Figure 44: RCB Status Panel LEDs



1– Power ( <b>PWR</b> ) LED	3– Primary ( <b>MST</b> ) LED
2– Status ( <b>STS</b> ) LED	4– Offline button

[Table 33 on page 84](#) describes the LEDs on the RCB status panel.

Table 33: Routing Control Board Status LEDs

LED	Color	State	Description
<b>PWR</b>	Green	On steadily	The RCB is receiving adequate power.
	Yellow	Blinking	The RCB has detected an error.
	Dark	Unlit	The RCB is not powered up.
<b>STS</b>	Green	On steadily	The RCB is online and functioning correctly.

**Table 33: Routing Control Board Status LEDs (Continued)**

LED	Color	State	Description
	Green	Blinking	The beacon feature is enabled.
	Yellow	On steadily	The RCB is booting.
	Yellow	Blinking	The RCB has detected an error.
	Dark	Unlit	The power supply is switched off.
<b>MST</b>	Green	On steadily	The RCB is the primary.
	Dark	Unlit	The RCB is the backup.

### QFX10000 Management Port LEDs

There are two management ports on the RCB of a QFX10008 and QFX10016 that have LEDs that indicate link status and link activity. These two ports, located on the RCB panel between the clocking connections and the USB port, are both labeled **MGMT**. The left management port is an SFP cage that can accommodate up to 1G copper or fiber connections (see [Figure 45 on page 85](#)). The copper (RJ-45) port has separate LEDs for status and activity. The fiber (SFP) port has a combination link and activity LED.

**Figure 45: Management Port LEDs on a QFX10000**

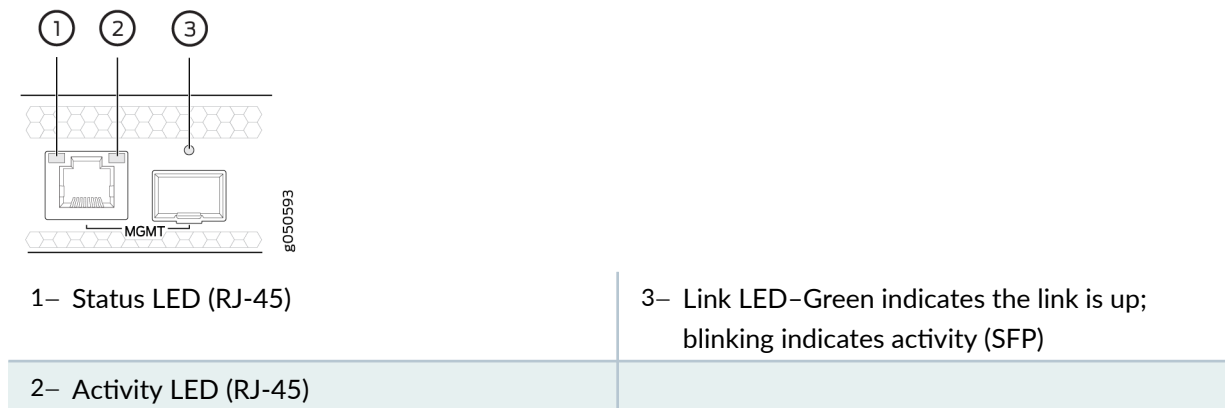




Table 34 on page 86 describes the RJ-45 management port LEDs, and Table 35 on page 86 describes the SFP status LEDs.

**Table 34: RJ-45 Management Port LEDs on a QFX10000 RCB**

LED	Color	State	Description
Port speed	Unlit	Off	The port speed is 10 MB.
	Green	Blinking	The port speed is 100 MB.
	Green	On steadily	The port speed is 1000 MB.
Link/Activity/Status	Unlit	Off	No link is established, there is a fault, or the link is down.
	Green	On steadily	A link is established.
		Blinking	There is link activity.
	Yellow	Blinking or flickering	The beacon feature is enabled.

**Table 35: SFP Management Port LEDs on a QFX10000 RCB**

LED	Color	State	Description
Link/Activity/Status	Unlit	Off	No transceiver is present.
	Green	On steadily	A link is established. The interface is up.
	Green	Blinking or flickering	The beacon feature is enabled.
	Yellow	Blinking	An error has occurred.

## SATA SSD LEDs

The Serial Advanced Technology Attachment (SATA) solid-state drive (SSD) LEDs indicate the status of the optional drive.

[Table 36 on page 87](#) describes the LEDs for the optional SATA drive.

**Table 36: Control Board Status LEDs**

LED	Color	State	Description
SSD	Green	On steadily	A SATA drive is present.
	Green	Blinking	The drive is active.
	Yellow	On steadily	The drive is active.
	Dark	Unlit	A drive is not installed.

## Virtual Port Connections

The four small form-factor pluggable plus (SFP+) ports are reserved for future use.

### RELATED DOCUMENTATION

[Handling and Storing QFX10000 Line Cards, RCBs, and SIBs | 226](#)

[Maintaining QFX10000 Routing and Control Boards | 230](#)

[Connect a Device to a Network for Out-of-Band Management | 219](#)

# QFX10000 Line Cards

## IN THIS SECTION

- [QFX10000-30C Line Card | 88](#)
- [QFX10000-30C-M Line Card | 93](#)
- [QFX10000-36Q Line Card | 99](#)
- [QFX10000-60S-6Q Line Card | 107](#)
- [QFX10K-12C-DWDM Coherent Line Card | 114](#)
- [1.2-Terabyte Per Second DWDM OTN Module Wavelengths | 120](#)
- [QFX10000 Line Card LEDs | 146](#)
- [Offline Button | 147](#)

## QFX10000-30C Line Card

### IN THIS SECTION

- [Overview | 89](#)
- [Channelizing 40-Gigabit Ports | 89](#)
- [Switch Ports | 91](#)
- [Status and Activity LEDs | 91](#)

The QFX10000-30C line card consists of thirty 28-Gbps QSFP+ Pluggable Solution (QSFP28) cages that support 40-Gigabit Ethernet or 100-Gigabit Ethernet optical transceivers. The QFX10000-30C ports automatically detect the type of transceiver installed and set the configuration to the appropriate speed. The line card can support 10-Gigabit Ethernet by channelizing the 40-Gigabit ports. Channelization is supported on fiber breakout cable using standard structured cabling techniques.

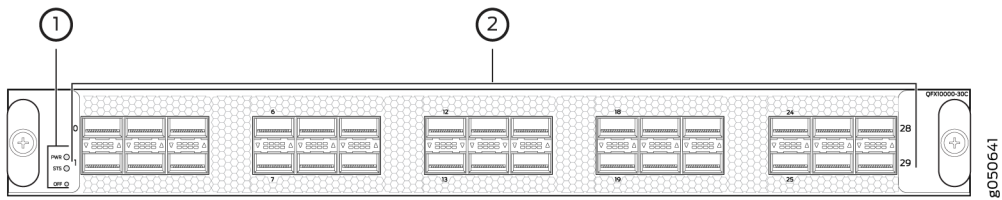
The QFX10000-30C line card is supported on Junos OS Release 15.1X53-D30 and later. Support for channelizing the 40-Gigabit Ethernet ports to four independent 10-Gigabit Ethernet ports is supported in Junos OS Release 17.1R1 and later.

This topic describes:

### Overview

The line cards in QFX10000 modular switches combine a Packet Forwarding Engine and Ethernet interfaces in a single assembly. Line cards are field-replaceable units (FRUs) that can be installed in the line card slots on the front of the switch chassis. The line cards are hot-insertable and hot-removable; you can remove and replace them without powering off the switch or disrupting switch functions. See [Figure 46 on page 89](#).

**Figure 46: QFX10000-30C Port Panel**



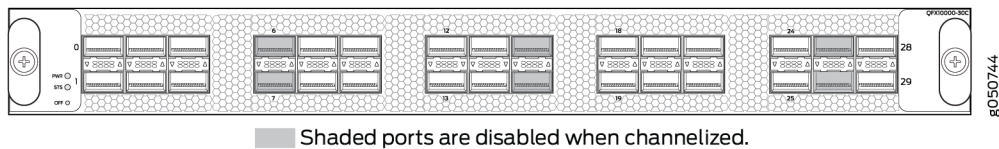
1– Power and status LEDs

2– Network ports

### Channelizing 40-Gigabit Ports

Beginning with Junos OS Release 17.1R1, 40-Gigabit Ethernet ports on the QFX10000-30C line card can be channelized to 10-Gigabit Ethernet. When ports are in channelization mode, every fourth port is disabled. See [Figure 47 on page 89](#) to see which ports are disabled and see [Table 37 on page 90](#) for the maximum port configurations.

**Figure 47: Disabled Ports in Channelization Mode**



**Table 37: Maximum Port Configuration**

Port Speed	Non-Channelized Mode (Mode D)	Channelized Mode (Mode A)
100 Gbps	30 or	24 or
40 Gbps	30	24 or
10 Gbps	0	96

Unlike the QFX10000-36C line card, the QFX10000-30C line card does not have port groups; instead, port behavior is tied to the ASIC associated with the port. You must configure each port individually, in order to channelize a 40-Gigabit Ethernet port to 4 independent 10-Gigabit Ethernet ports. The first time a port for an associated ASIC is changed from the default configuration mode (mode D) to the channelization mode (mode A), the FPC reboots. Subsequent channelization of the ports for that ASIC does not cause the FPC to reboot. However if the last channelized port is changed back to the default configuration mode, the FPC will again reboot. See [Table 38 on page 90](#) for the list of available ports and the associated ASIC and [Figure 47 on page 89](#) to locate the available and disabled ports.



**CAUTION:** Changing the channelization mode (mode D to mode A or mode A to mode D) causes the FPC to reboot. Because there can be a slight loss of data while the FPC reboots, we recommend that you only configure the changes during a maintenance window.

**Table 38: Port Mapping for Channelization**

ASIC	Available Ports	Disabled Port
PE0	0, 2, 4, 6, 8	6
PE1	1, 3, 5, 7, 9	7
PE2	10, 12, 14, 16, 18	16
PE3	11, 13, 15, 17, 19	17
PE4	20, 22, 24, 26, 28	26

**Table 38: Port Mapping for Channelization (Continued)**

ASIC	Available Ports	Disabled Port
PE5	21, 23, 25, 27, 29	27

To change from the default mode to 40-Gigabit Ethernet channelized mode, use the Junos OS operational command **set chassis fpc *slot-number* pic 0 port *port number* channel-speed 10g**.

## Switch Ports

Each of the 30 QSFP28 ports supports:

- 100-Gigabit Ethernet using QSFP28 optical transceivers. When a QSFP28 transceiver is inserted into any of the ports, the QSFP28 port is enabled for 100-Gigabit Ethernet.
- 40-Gigabit Ethernet using QSFP+ optical transceivers. When a QSFP+ transceiver is inserted into any of the ports, the QSFP+ port is enabled for 40-Gigabit Ethernet.
- 100-Gigabit Ethernet active optic cables (AOC)
- QSFP28 direct attach copper (DAC) cables
- QSFP+ DAC cables
- QSFP+ to SFP+ direct attach copper breakout (DACBO) cables
- Access ports—You can use 40-Gigabit Ethernet QSFP+ transceivers and QSFP+ DAC cables in any downstream port. See "[QFX10000 Optical Transceiver and Cable Support](#)" on page 171.
- Uplink ports—You can configure all the QSFP28 ports as uplinks.

On the QFX10000-30C, the ports are enabled by default, and the default configuration adds the ports to the default VLAN.

## Status and Activity LEDs

All QSFP28 ports have an up or down indicator for each port and four bi-colored LEDs that show port status and link activity based on whether or not the port is configured for channelization. See [Figure 48 on page 92](#) and [Table 39 on page 92](#).

Figure 48: Indicators for QSFP28 Ports on QFX10000-30C Line Cards

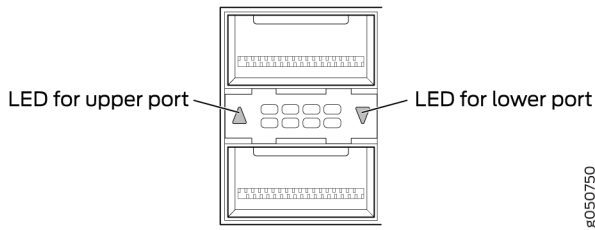


Table 39: Network Port Status and Activity LEDs on a QFX10000-30C Line Card

Color	State	Description
Unlit	Off	The port is administratively disabled, there is no power, the link is down, or a transceiver is not present. All sub-channels are disabled.
Green	On steadily	A link is established. When channelized, all sub-channels are up. When not channelized, it indicates no activity.
	Blinking	A link is up and there is activity. When not channelized, it indicates the port is up and active in either 40-Gigabit or 100-Gigabit mode. When channelized, all four channels are up and active.
Yellow or Amber (channelized)	On steadily	At least one channel link is up, but not all channels are up. There is no activity on the channel link.
	Flashing	At least one channel link is up, but not all channels are up. There is activity on the channel link.
	Slow blink, or blip	The beacon function is enabled on one or more sub-channels.
	Blinking	One or more sub-channels has a fault condition.
Yellow or Amber (non-channelized)	Blinking	A single LED blinking indicates an interface fault. All four LEDs blink to indicate the beacon function was enabled on the port.

## SEE ALSO

[QFX10000 Field-Replaceable Units | 23](#)

*Channelizing Interfaces on QFX3500, QFX3600, QFX5100, QFX10002, QFX10008, QFX10016, and EX4600 Switches*

[QFX10000 Line Card LEDs | 146](#)

[Installing a QFX10000 Line Card | 313](#)

## QFX10000-30C-M Line Card

### IN THIS SECTION

- [Overview | 94](#)
- [Channelizing 40-Gigabit Ports | 94](#)
- [Network Ports | 96](#)
- [Power and Status LEDs | 96](#)
- [Port Status and Activity LEDs | 97](#)

The QFX10000-30C-M line card is designed to provide secure Ethernet communication across high-speed links. The card consists of 30 ports of 28 Gbps QSFP+ Pluggable Solution (QSFP28) that are Media Access Control Security (MACsec) capable. The ports support speeds of 100 Gbps or 40 Gbps and can automatically detect the type of transceiver installed and set the configuration to the appropriate speed.

As part of Juniper Networks Open Cloud Interconnect, the QFX10000-30C-M line card brings secure data center interconnect (DCI), inter-data center and intra-data center connectivity using MACsec at 100 Gbps and 40 Gbps speeds. When configured for 40 Gigabit Ethernet, a QSFP28 port can breakout to 4 independent 10 small form-factor pluggable plus+ (SFP+) ports. MACsec provides point-to-point security on Ethernet links between directly connected nodes and is capable of identifying and preventing most security threats, including denial of service, intrusion, man-in-the-middle, masquerading, passive wiretapping, and playback attacks.

The QFX10000-30C-M line card is supported on Junos OS Release 17.4R1-S2 and later. Support for channelizing the 40-Gigabit Ethernet ports to four independent 10-Gigabit Ethernet ports is supported in Junos OS Release 19.2R1 and later.

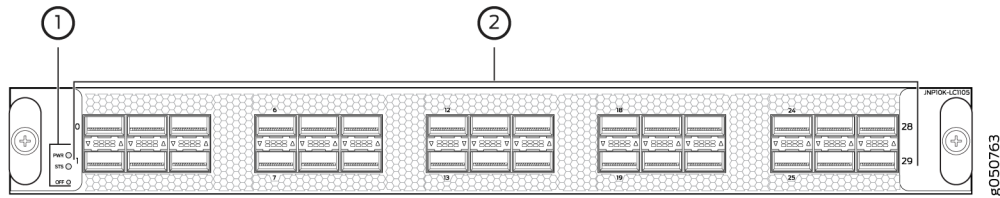
This topic describes:



## Overview

The line cards in QFX10000 modular switches combine a Packet Forwarding Engine and Ethernet interfaces in a single assembly. Line cards are field-replaceable units (FRUs) that can be installed in the line card slots on the front of the switch chassis. The line cards are hot-insertable and hot-removable; you can remove and replace them without powering off the switch or disrupting switch functions. See [Figure 49 on page 94](#).

**Figure 49: QFX10000-30C-M Port Panel**



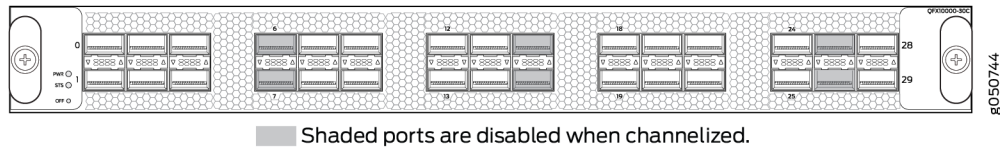
1– Power LED, status LED, and offline button

2– Network ports

## Channelizing 40-Gigabit Ports

Beginning with Junos OS Release 18.2R1, 40-Gigabit Ethernet ports on the QFX10000-30C-M line card can be channelized to 10-Gigabit Ethernet. When ports are in channelization mode, every fourth port is disabled. See [Figure 50 on page 94](#) to see which ports are disabled and see [Table 40 on page 94](#) for the maximum port configurations.

**Figure 50: Disabled Ports in Channelization Mode**



**Table 40: Maximum Port Configuration**

Port Speed	Non-Channelized Mode (Mode D)	Channelized Mode (Mode A)
100 Gbps	30 or	24 or

**Table 40: Maximum Port Configuration (Continued)**

Port Speed	Non-Channelized Mode (Mode D)	Channelized Mode (Mode A)
40 Gbps	30	24 or
10 Gbps	0	96

Unlike the QFX10000-36C line card, the QFX10000-30C-M line card does not have port groups; instead, port behavior is tied to the ASIC associated with the port. You must configure each port individually, in order to channelize a 40-Gigabit Ethernet port to 4 independent 10-Gigabit Ethernet ports. The first time a port for an associated ASIC is changed from the default configuration mode (mode D) to the channelization mode (mode A), the FPC reboots. Subsequent channelization of the ports for that ASIC does not cause the FPC to reboot. However if one of the channelized ports is changed back to the default, the FPC will again reboot. See [Table 41 on page 95](#) for the list of available ports and the associated ASIC and [Figure 50 on page 94](#) to locate the available and disabled ports.



**CAUTION:** Changing the channelization mode (mode D to mode A or mode A to mode D) causes the FPC to reboot. Because there can be a slight loss of data while the FPC reboots, we recommend that you only configure the changes during a maintenance window.

**Table 41: Port Mapping for Channelization**

ASIC	Available Ports	Disabled Port
PE0	0, 2, 4, 6, 8	6
PE1	1, 3, 5, 7, 9	7
PE2	10, 12, 14, 16, 18	16
PE3	11, 13, 15, 17, 19	17
PE4	20, 22, 24, 26, 28	26
PE5	21, 23, 25, 27, 29	27

To change from the default mode to 40-Gigabit Ethernet channelized mode, use the Junos OS operational command `set chassis fpc slot-number pic 0 port port number channel-speed 10g`.

## Network Ports

Each of the 30 QSFP28 ports supports:

- 100-Gigabit Ethernet using QSFP28 optical transceivers. When a QSFP28 transceiver is inserted into any of the ports, the QSFP28 port is enabled for 100-Gigabit Ethernet.
- 40-Gigabit Ethernet using QSFP+ optical transceivers. When a QSFP+ transceiver is inserted into any of the ports, the QSFP+ port is enabled for 40-Gigabit Ethernet.
- QSFP+ to SFP+ direct attach copper breakout (DACBO) cables

On the QFX10000-30C-M, the ports are enabled by default, and the default configuration adds the ports to the default VLAN.

## Power and Status LEDs

The two LEDs to the left of the network ports indicate the power (**PWR**) and status (**STS**) for the line card. See [Table 42 on page 96](#) and [Table 43 on page 96](#).

**Table 42: Power LED**

Color	State	Description
Unlit	Off	There is no power to the line card.
Green	On steadily	The line card has power.
Yellow or amber	Blinking	The line card has a power fault.

**Table 43: Status LED**

Color	State	Description
Unlit	Off	The line card is offline or disabled..
Green	On steadily	The line card is online.

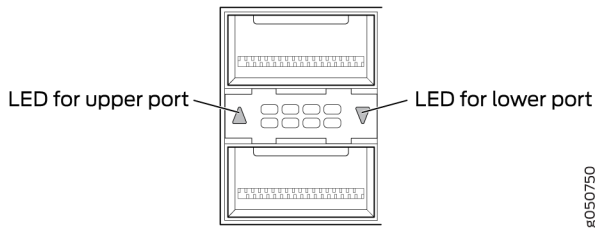
**Table 43: Status LED (Continued)**

Color	State	Description
Yellow or amber	On steadily	The line card is booting.
	Blinking	The line card has a fault condition or alarm.
	Slow blink or blip	The beacon function is enabled.

### Port Status and Activity LEDs

Each QSFP28 port has a bi-colored up or down LED indicator that show port status and link activity. See [Figure 51 on page 97](#) and [Table 44 on page 97](#).

**Figure 51: Indicators for QSFP28 Ports on QFX10000-30C-M Line Cards**



**Table 44: Network Port Status and Activity LEDs on a QFX10000-30C-M Line Card**

Color	State	Description
Unlit	Off	The port is administratively disabled, there is no power, the link is down, or a transceiver is not present. All sub-channels are disabled.
Green	On steadily	A link is established. When channelized, all sub-channels are up. When not channelized, it indicates no activity.

**Table 44: Network Port Status and Activity LEDs on a QFX10000-30C-M Line Card (Continued)**

Color	State	Description
	Blinking	A link is up and there is activity. When not channelized, it indicates the port is up and active in either 40-Gigabit or 100-Gigabit mode. When channelized, all four channels are up and active.
Yellow or Amber (channelized)	On steadily	At least one channel link is up, but not all channels are up. There is no activity on the channel link.
	Flashing	At least one channel link is up, but not all channels are up. There is activity on the channel link.
	Slow blink, or blip	The beacon function is enabled on one or more sub-channels.
	Blinking	One or more sub-channels has a fault condition.
Yellow or Amber	Blinking	A single LED blinking indicates an interface fault. All four LEDs blink to indicate the beacon function was enabled on the port.

## SEE ALSO

[QFX10000 Field-Replaceable Units | 23](#)

*Configuring MACsec on EX, QFX and SRX Devices*

*Channelizing Interfaces on QFX3500, QFX3600, QFX5100, QFX10002, QFX10008, QFX10016, and EX4600 Switches*

[Installing a QFX10000 Line Card | 313](#)

## QFX10000-36Q Line Card

### IN THIS SECTION

- Overview | 99
- Switch Ports | 100
- Status and Activity LEDs | 105

The QFX10000-36Q line card consists of 36 quad small form-factor pluggable plus (QSFP+) ports that support 40-Gigabit Ethernet optical transceivers. Out of these 36 ports, 12 ports are QSFP28 capable. The QSFP28 capable ports are dual speed and can support either 40-Gigabit or 100-Gigabit Ethernet optical transceivers. The line card can support 10-Gigabit Ethernet by channelizing the 40-Gigabit ports. Channelization is supported on fiber breakout cable using standard structured cabling techniques.

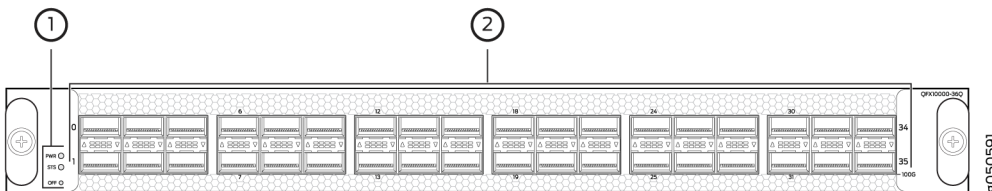
The QFX10000-36Q line card is supported on Junos OS Release 15.1X53-D30 and later.

This topic describes:

### Overview

The line cards in QFX10000 modular switches combine a Packet Forwarding Engine and Ethernet interfaces in a single assembly. Line cards are field-replaceable units (FRUs) that can be installed in the line card slots on the front of the switch chassis. The line cards are hot-insertable and hot-removable; you can remove and replace them without powering off the switch or disrupting switch functions. See [Figure 52 on page 99](#).

Figure 52: QFX10000-36Q Port Panel



1– Status and activity LEDs

2– Network ports

Each QSFP28 socket can be configured to support:

- 100-Gigabit Ethernet using QSFP28 optical transceivers. When a QSFP28 transceiver is inserted into the ports marked with a fine black line underneath the socket and the port is configured for 100-Gigabit Ethernet, the two adjacent ports are disabled and the QSFP28 socket is enabled for 100-Gigabit Ethernet.
- 40-Gigabit Ethernet using QSFP+ optical transceivers.
- 10-Gigabit Ethernet using breakout cabling and attached optical transceivers. When configured for channelization, the system converts the 40-Gigabit Ethernet port into 4 independent 10-Gigabit Ethernet ports.

Any of the 36 ports **0** through **35** can be configured as either uplink or access ports.

## Switch Ports

Each of the 12 QSFP28 ports supports:

- 100-Gigabit Ethernet QSFP28 transceivers
- 40-Gigabit Ethernet QSFP+ transceivers
- QSFP28 direct attach copper (DAC) cables
- QSFP+ DAC cables
- QSFP+ to SFP+ direct attach copper breakout (DACBO) cables

Each of the 36 QSFP+ ports supports:

- 40-Gigabit Ethernet QSFP+ transceivers
- QSFP+ DAC cables
- QSFP+ to SFP+ fiber breakout and DACBO cables
- Access ports

You can use 40-Gigabit Ethernet QSFP+ transceivers and QSFP+ DAC cables in any downstream port. See ["QFX10000 Optical Transceiver and Cable Support" on page 171](#).

- Uplink ports

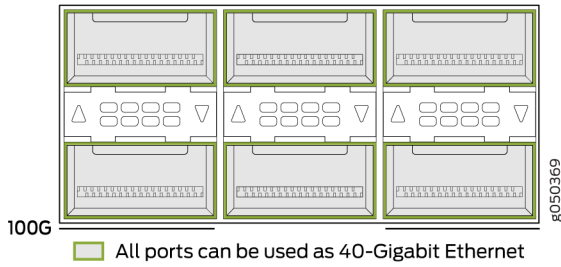
You can configure all the QSFP+ ports as uplinks.

Every second and sixth port in a 6XQSFP cage on a QFX10000-36Q supports 100-Gigabit Ethernet using QSFP28 transceivers. These 100-Gigabit Ethernet ports work either as 100-Gigabit Ethernet or as 40-Gigabit Ethernet, but are recognized as 40-Gigabit Ethernet by default. See [Figure 53 on page 101](#) for a closeup view of a 6XQSFP+ cage. When a 40-Gigabit Ethernet transceiver is inserted into a 100-

Gigabit Ethernet port, the port recognizes the 40-Gigabit Ethernet port speed. When a 100-Gigabit Ethernet transceiver is inserted into the port and enabled in the CLI, the port recognizes the 100-Gigabit Ethernet speed and disables two adjacent 40-Gigabit Ethernet ports. See [Figure 54 on page 101](#) and [Figure 55 on page 102](#). You can also use an 100-Gigabit Ethernet transceiver and run it at 40-Gigabit Ethernet by using the CLI to set the port speed to 40-Gigabit Ethernet.

[Figure 53 on page 101](#) shows the location of QSFP+ ports for the QFX10000-36Q.

**Figure 53: All Ports Are Enabled for 40-Gigabit Ethernet by Default**



**Figure 54: 100-Gigabit Ethernet Ports**

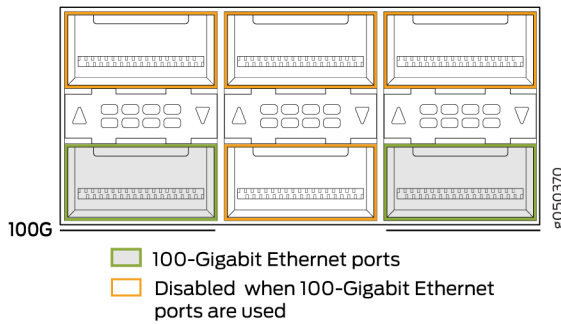
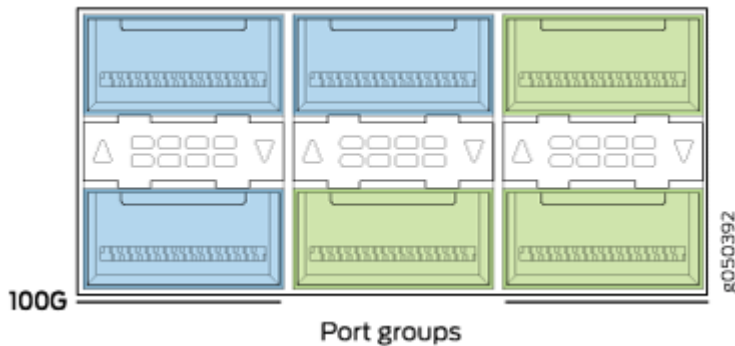


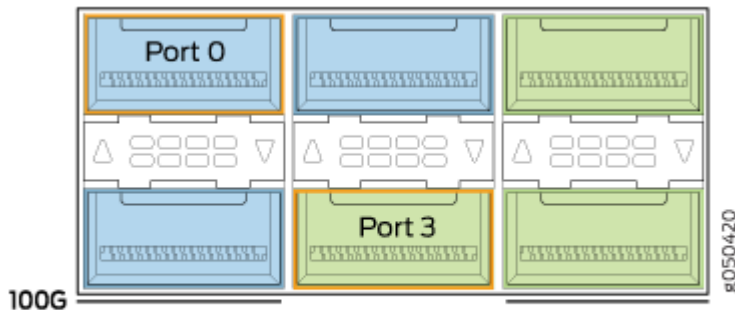


Figure 55: 100-Gigabit Ethernet Port Disables Two Associated 40-Gigabit Ethernet Ports



The 40-Gigabit Ethernet ports can operate independently or bundled with the next two consecutive ports and channelized into twelve 10-Gigabit Ethernet ports as a port range. You cannot channelize an individual port on this card. Each port is part of a port group of 3. Only the first and fourth port in each 6XQSFP cage are available to channelize a port range (see [Figure 56 on page 102](#)). The port range must be configured using the `set chassis fpc pic port channel-speed` command. For example, to channelize the first switch port, use the `set chassis fpc 0 pic 0port 1channel-speed 10g` command.

Figure 56: Use the First and Fourth Port in Each 6XQSFP Cage to Channelize a Port Range



Use every third port to create a port range for 40-Gigabit Channelization.

[Table 45 on page 103](#) shows the available combinations for the ports. Most 100-Gigabit Ethernet transceiver ports are used as uplinks. On the QFX10000-36Q, the ports are enabled by default, and the default configuration adds the ports to the default VLAN.

Table 45: QFX10000-36Q Port Mapping

Port Number	4X10-Gigabit Ethernet	4X10-Gigabit Channelized Port Group	40-Gigabit Ethernet	100-Gigabit Ethernet	100-Gigabit Ethernet Disables
0	✓	✓	✓	-	-
1	✓		✓	✓	0, 2
2	✓		✓	-	-
3	✓	✓	✓	-	-
4	✓		✓	-	-
5	✓		✓	✓	3, 4
6	✓	✓	✓	-	-
7	✓		✓	✓	6, 8
8	✓		✓	-	-
9	✓	✓	✓	-	-
10	✓		✓	-	-
11	✓		✓	✓	9, 10
12	✓	✓	✓	-	-
13	✓		✓	✓	12, 14
14	✓		✓	-	-

Table 45: QFX10000-36Q Port Mapping (Continued)

Port Number	4X10-Gigabit Ethernet	4X10-Gigabit Channelized Port Group	40-Gigabit Ethernet	100-Gigabit Ethernet	100-Gigabit Ethernet Disables
15	✓	✓	✓	-	-
16	✓		✓	-	-
17	✓		✓	✓	15, 16
18	✓	✓	✓	-	-
19	✓		✓	✓	18, 20
20	✓		✓	-	-
21	✓	✓	✓	-	-
22	✓		✓	-	-
23	✓		✓	✓	21, 22
24	✓	✓	✓	-	-
25	✓		✓	✓	24, 26
26	✓		✓	-	-
27	✓	✓	✓	-	-
28	✓		✓	-	-
29	✓		✓	✓	27, 28

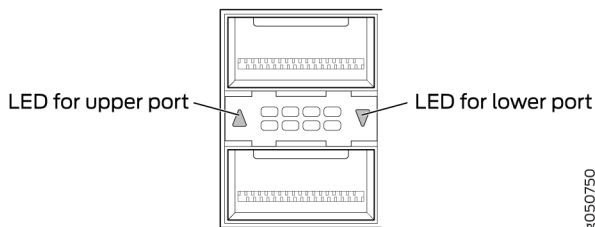
Table 45: QFX10000-36Q Port Mapping (Continued)

Port Number	4X10-Gigabit Ethernet	4X10-Gigabit Channelized Port Group	40-Gigabit Ethernet	100-Gigabit Ethernet	100-Gigabit Ethernet Disables
30	✓	✓	✓	-	-
31	✓		✓	✓	30, 32
32	✓		✓	-	-
33	✓	✓	✓	-	-
34	✓		✓	-	-
35	✓		✓	✓	33, 34

### Status and Activity LEDs

All ports have an up or down indicator for each port and four bi-colored LEDs that show port status and link activity based on whether or not the port is configured for channelization. See [Figure 57 on page 105](#) and [Table 46 on page 106](#).

Figure 57: LED Indicators for QSFP+ and QSFP28 Ports



8050750

**Table 46: Network Port Status and Activity LEDs on a QFX10000-36Q Line Card**

Color	State	Description
Unlit	Off	The port is administratively disabled, there is no power, the link is down, or a transceiver is not present. All sub-channels are disabled.
Green	On steadily	A link is established. When channelized, all sub-channels are up. When not channelized, it indicates no activity.
	Blinking	A link is up and there is activity. When not channelized, it indicates the port is up and active in either 40-Gigabit or 100-Gigabit mode. When channelized, all four channels are up and active.
Yellow or Amber (channelized)	On steadily	At least one channel link is up, but not all channels are up. There is no activity on the channel link.
	Flashing	At least one channel link is up, but not all channels are up. There is activity on the channel link.
	Slow blink, or blip	The beacon function is enabled on one or more sub-channels.
	Blinking	One or more sub-channels has a fault condition.
Yellow or Amber (non-channelized)	Blinking	A single LED blinking indicates an interface fault. All four LEDs blink to indicate the beacon function was enabled on the port.

**SEE ALSO**

[QFX10000 Field-Replaceable Units](#) | 23

## QFX10000-60S-6Q Line Card

### IN THIS SECTION

- [Hardware Features | 107](#)
- [Port Groups | 109](#)
- [Channelization of 40-Gigabit Ethernet Ports | 110](#)
- [Using Copper and Fiber SFP Transceivers | 110](#)
- [SFP+ Status and Activity LEDs | 112](#)
- [QSFP+ and QSFP28 Status and Activity LEDs | 113](#)

The QFX10000-60S-6Q line card consists of 60 small form-factor pluggable plus (SFP+) ports, that support 10-Gbps or 1-Gbps port speeds, 2 dual-speed QSFP28 ports that support either 40-Gbps or 100-Gbps port speed, and 4 QSFP+ ports that support 40-Gbps. All of the SFP+ ports are configured to 10-Gbps by default. The QSFP28 ports are configured to 40-Gbps by default, but port **60** and port **64** are dual-speed ports and can be configured to support either 40-Gigabit Ethernet or 100-Gigabit Ethernet optical transceivers. See the [Hardware Compatibility Tool](#) for details of supported optical transceivers.

The QFX10000-60S-6Q line card is supported on Junos OS Release 17.1R1 and later.

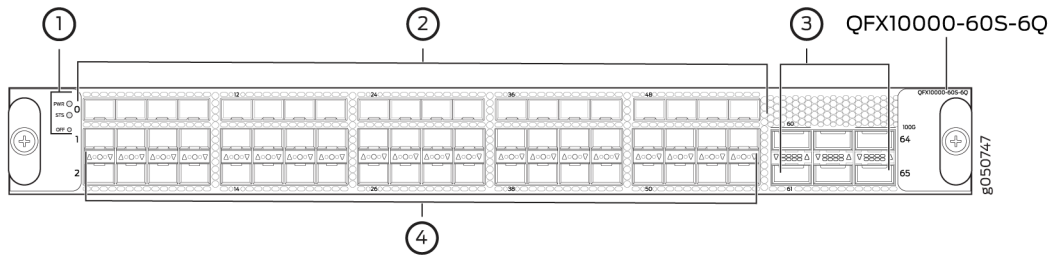
**NOTE:** Junos OS Release 17.1R1 does not support 1-Gigabit Ethernet on the 10-Gigabit Ethernet SFP+ ports. Junos OS Release 17.2R1 supports 1-Gigabit Ethernet on the 10-Gigabit Ethernet SFP+ ports.

This topic describes:

### Hardware Features

The line cards in QFX10000 modular switches combine a Packet Forwarding Engine and Ethernet interfaces in a single assembly. Line cards are field-replaceable units (FRUs) that can be installed in the line card slots on the front of the switch chassis. The line cards are hot-insertable and hot-removable; you can remove and replace them without powering off the switch or disrupting switch functions. See [Figure 58 on page 108](#).

Figure 58: QFX10000-60S-6Q Port Panel



1– Power LED, status LED, and offline button	3– QSFP28 ports, QSFP+ ports, and port groups
2– SFP+ ports	

Each QSFP28 port (**60** and **64**) controls a port group and can be configured to support:

- 100-Gigabit Ethernet using QSFP28 optical transceivers. The interface speeds are configured by port group. When a QSFP28 transceiver is inserted into the one of the QSFP28 ports marked with a fine black line above the port (**60** or **64**) and the port is configured for 100-Gigabit Ethernet, the two adjacent ports are disabled and the QSFP28 port is enabled for 100-Gigabit Ethernet. When port **60** is configured for 100-Gbps, ports **61** and **62** are disabled; when port **64** is configured for 100-Gbps, ports **63** and **65** are disabled.
- 40-Gigabit Ethernet using QSFP+ optical transceivers. The default speed is 40 Gbps.
- 10-Gigabit Ethernet using breakout cabling and attached optical transceivers. When configured for channelization, the system converts the 40-Gigabit Ethernet port into 4 independent 10-Gigabit Ethernet ports. Use the `set chassis fpc slot-number port port-number channel-speed speed` command to change the port speed.

Each QSFP+ port (**61**, **62**, **63**, and **65**) is part of a port group and is controlled either by the associated QSFP28 port (**60** or **64**). A QSFP28 port operating at 40-Gbps speeds, the QSFP+ ports can be configured to support:

- 40-Gigabit Ethernet using QSFP+ optical transceivers. The default speed is 40 Gbps.
- 10-Gigabit Ethernet using breakout cables with attached optical transceivers. When configured for channelization, the system converts the 40-Gigabit Ethernet port into 4 independent 10-Gigabit Ethernet ports. Use the `set chassis fpc slot-number port port-number channel-speed speed` command to change the port speed.

Each SFP+ port (**0** through **59**) can be configured to support:

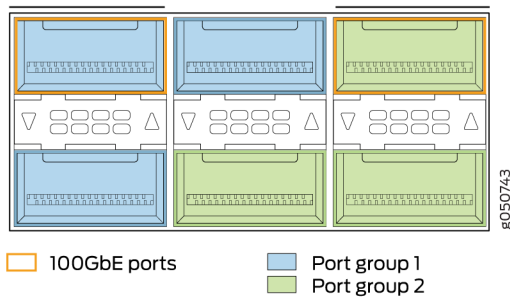
- 10-Gigabit Ethernet using SFP+ optical transceivers. The default speed is 10 Gbps.
- 1-Gigabit Ethernet using SFP optical or SFP-T copper transceivers. See ["Using Copper and Fiber SFP Transceivers"](#) on page 107.

Any of the 66 ports **0** through **65** can be configured as either uplink or access ports. The ports are enabled by default, and the default configuration adds the ports to the default VLAN.

### Port Groups

The six combination ports of QSFP28 and QSFP+ can operate either as six independent 40-Gigabit Ethernet ports or as two port groups. The first port group is controlled by QSFP28 port **60** and administratively bundled with QSFP+ ports **61** and **62**. The second port group is controlled by QSFP28 port **64** and administratively bundled with QSFP+ ports **63** and **65**. To enable the port group, insert a 100-Gigabit Ethernet transceiver into the QSFP28 port and configure a port for 100-Gbps. Junos OS enables the QSFP28 port at 100-Gbps speed and disables the two QSFP+ ports bundled in the port group. [Figure 59 on page 109](#) shows the location of QSFP28 ports and port groups for the QFX10000-60S-6Q. [Table 47 on page 109](#) shows the available combinations for the ports.

**Figure 59: QFX10000-60S-6Q Port Groups**



**Table 47: QFX10000-60S-6Q Port Mapping**

Port Number	4X10-Gigabit Ethernet	4X10-Gigabit Channelized Port Group	40-Gigabit Ethernet	100-Gigabit Ethernet	100-Gigabit Ethernet Disables
60	✓	✓	✓	✓	61, 62
61	✓		✓	-	-
62	✓		✓	-	-
63	✓	✓	✓	-	-



Table 47: QFX10000-60S-6Q Port Mapping (Continued)

Port Number	4X10-Gigabit Ethernet	4X10-Gigabit Channelized Port Group	40-Gigabit Ethernet	100-Gigabit Ethernet	100-Gigabit Ethernet Disables
64	✓		✓	✓	63, 65
65	✓		✓	-	-

## Channelization of 40-Gigabit Ethernet Ports

Channelization from a 40-Gigabit Ethernet port into 4 independent 10-Gigabit Ethernet ports is supported on the QSFP28 and QSFP+ ports. Channelization to 50-Gbps or 25-Gbps speed is not supported on the 100-Gigabit Ethernet QSFP28 port. All ports in the port group are channelized when port **60** or port **64** are channelized. Ports cannot be channelized individually.

To channelize a 40-Gbps port to 4 independent 10-Gbps ports, use the `set chassis fpc slot-number pic pic-number port port-number channel-speed speed` command. For example, to channelize ports **60** through **62** for a line card in slot **6**:

```
[edit chassis fpc 6 pic 1]
user@switch# set port 60 channel-speed 10g
```

Review your configuration and issue the `commit` command.

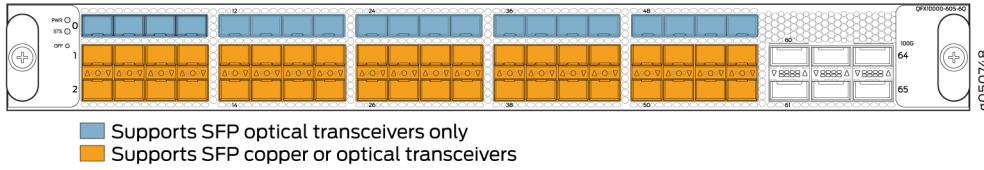
If you want to return the port to the default, delete the `speed` statement from the configuration at the `[chassis fpc 6 pic 1 port port-number]` hierarchy level and commit the configuration. The network port is reset to the default 40-Gigabit Ethernet interface.

```
[edit chassis fpc 6 pic 1]
user@switch# delete port 60 channel-speed 10g
```

## Using Copper and Fiber SFP Transceivers

When you configure the 10-Gigabit Ethernet ports **0** to **59** as 1-Gigabit Ethernet ports, you can use optical fiber SFP transceivers in any of the ports. However, copper SFP transceivers are restricted to the lower two rows. See [Figure 60 on page 111](#).

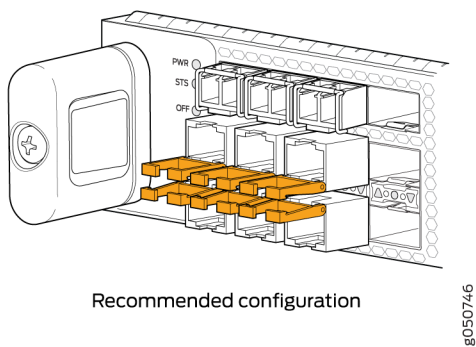
Figure 60: Supported Placement for Copper and Fiber SFP+ Transceivers



**CAUTION:** When you use the latest OEM part number FCLF8521P2BTL (printed on the transceiver label), you can install 1GbE transceivers (such as QFX-SFP-1GE-T) in any port with no restrictions. The same applies for devices that support 10GbE copper transceivers. However, if you are using the older OEM part number SP7041-M1-JN (not shipped in last 3+ years) instead, do not install 1GbE copper transceivers (such as QFX-SFP-1GE-T) directly above or below another 1GbE copper transceiver. Use only the top row or bottom row to avoid damage to the device caused when the transceivers are installed above or below each other.

Because 1 Gbps copper SFP transceivers are physically larger than optical SFP transceivers, there is insufficient room for 3 copper SFP transceivers to be stacked. Use the top row only for optical SFP transceivers. You can stack copper transceivers in the bottom two rows. Ports are arranged belly-to-belly. Stacking three SFP transceivers in a column can damage the line card. For the recommended configuration, see [Figure 61 on page 111](#).

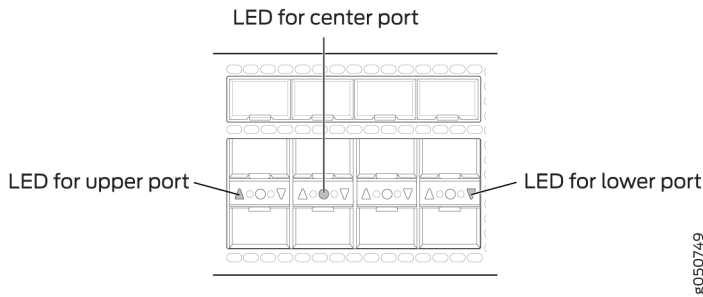
Figure 61: Belly-to-Belly SFP Transceivers



### SFP+ Status and Activity LEDs

All status and activity LEDs for the SFP+ ports are located between the second and third rows of SFP+. The up arrow, circle, and down arrow indicate the row of the status. A bi-color LED indicates the status and activity. See [Figure 62 on page 112](#) and [Table 48 on page 112](#).

**Figure 62: SFP+ Port Indicators and Status LEDs on a QFX10000-60S-6Q Line Card**



- An up arrow indicates the first row.
- A circle indicates the second row.
- A down arrow indicates the third row.

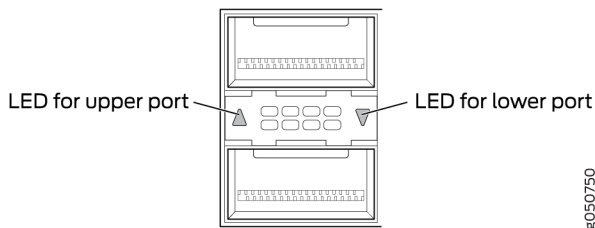
**Table 48: Network Port Status and Activity LEDs for SFP+ Ports on a QFX10000-60S-6Q Line Card**

Color	State	Description
Unlit	Off	The port is administratively disabled, there is no power, the link is down, or a transceiver is not present.
Green	On steadily	A link is established.
Yellow or Amber	Slow blink, or blip	The beacon function is enabled on one or more sub-channels.
	Blinking	The interface has a fault condition.

## QSFP+ and QSFP28 Status and Activity LEDs

All QSFP+ and QSFP28 ports have an up or down indicator for each port and four bi-colored LEDs that show port status and link activity based on whether or not the port is configured for channelization. See [Table 49 on page 113](#).

**Figure 63: LED Indicators on QSFP+ and QSFP28 Ports on QFX10000-60S-6Q Line Card**



**Table 49: QSFP+ and QSFP28 Network Port Status and Activity LEDs**

Color	State	Description
Unlit	Off	The port is administratively disabled, there is no power, the link is down, or a transceiver is not present. All sub-channels are disabled.
Green	On steadily	A link is established. When channelized, all sub-channels are up. When not channelized, it indicates no activity.
Yellow or Amber	On steadily	At least one channel link is up, but not all channels are up.
	Slow blink, or blip	The beacon function is enabled on one or more sub-channels.
	Blinking	One or more sub-channels has a fault condition.

### SEE ALSO

[QFX10000 Field-Replaceable Units](#) | 23

## QFX10K-12C-DWDM Coherent Line Card

### IN THIS SECTION

- Hardware Features | 114
- Compatibility | 116
- Optical Transmit Specifications | 117
- Optical Receive Specifications | 118
- Status and Activity LEDs | 119

The QFX10K-12C-DWDM line card is the combination of Juniper Networks Junos OS for QFX10000 modular chassis software running on Juniper Networks JNP10K-LC1104 hardware. The QFX10000-12C-DWDM line card provides up to 1.2 Tbps packet forwarding for cloud providers, service providers, and enterprises that need coherent dense wavelength-division multiplexing (DWDM) with MACsec security features. The 6 port line card, with built-in optics, supports flexible rate modulation at 100 Gbps, 150 Gbps, and 200 Gbps speeds.

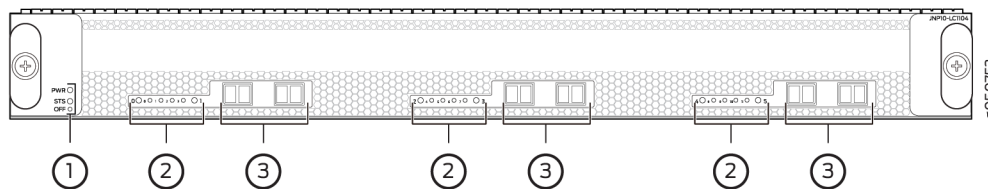
The QFX10K-12C-DWDM line card is supported on Junos OS Release 17.2R1 and later.

This topic includes:

### Hardware Features

The line cards in QFX10000 modular switches combine a Packet Forwarding Engine and Ethernet interfaces in a single assembly. Line cards are field-replaceable units (FRUs) that can be installed in the line card slots on the front of the switch chassis. The line cards are hot-insertable and hot-removable; you can remove and replace them without powering off the switch or disrupting switch functions. See [Figure 64 on page 114](#).

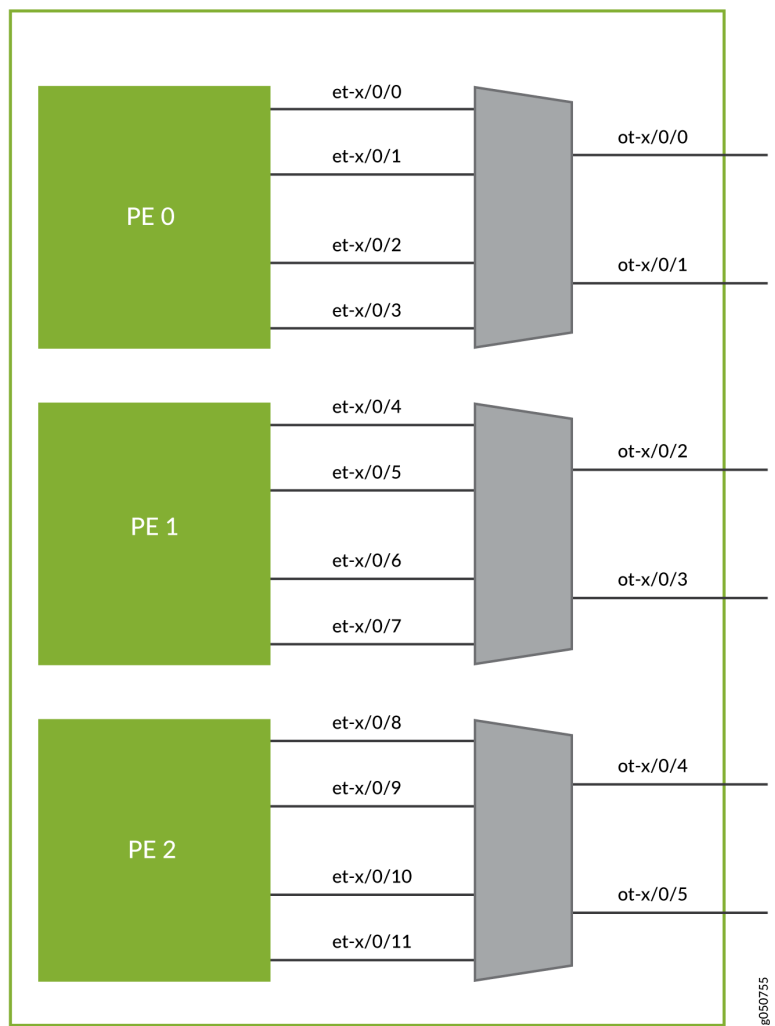
Figure 64: QFX10000-6C-DWDM Port Panel



1– Power and status LEDs	3– Ports with embedded optics
2– Network link and Ethernet link LEDs	

Each QFX10K-12C-DWDM has 6 physical interfaces (OT) that connect to one of three built-in flexible rate optical transponders. Each transponder connects four 100-Gigabit Ethernet logical interfaces (ET) to one of three forwarding ASICs. The ASICs through a MACsec to PHY to MACsec encryption is optionally supported on each 100-Gigabit Ethernet interface. See [Figure 65 on page 115](#).

**Figure 65: QFX10K-12C-DWDM Interfaces**



**NOTE:** All optical properties are configured under the OT interface. Use the **set interfaces ot-x/x/x optics-options** CLI command to set these options.

Each of the six network ports can operate in one of three modulation formats, see [Table 50 on page 116](#).

**Table 50: QFX10000-6C-DWDM Modulation**

Speed	Modulation	Distance
100 Gbps	DP-PSK	long haul–2485.49 miles (4000 km)
150 Gbps	DP-8QAM	regional or metro–1242.74 miles (2000 km)
200 Gbps	DP-16QAM	metro DCI–621.37 miles (1000 km)

## Compatibility

The Juniper Networks Open Cloud Interconnect solution includes integrated 100 GbE coherent optics on Juniper Networks QFX Series switches; MX Series 5G Universal Routing Platforms and PTX Series Packet Transport Routers; and BTI Packet Optical Platforms optimized for DCI. As part of the Open Cloud Interconnect solution, the QFX10K-12C-DWDM coherent line card is compatible with many third-party optical products as well as Juniper Networks optical solutions and offerings. The QFX10K-12C-DWDM coherent line card is interoperable with the BTI Series Packet Optical Transport UFM6 in 100 Gbps, 150 Gbps, and 200 Gbps modes. It is also compatible with the MX Series MICs and PTX Series PICs in 100 Gbps mode using SDFEC or SDFEC25 FEC. See [Table 51 on page 116](#).

**Table 51: Juniper Networks Compatible Products in 100 Gbps Mode**

Platform	Cards	Model Information
MX Series	MIC3-100G-DWDM	See the Hardware Compatibility Tool, <a href="#">MIC3-100G-DWDM</a> .
PTX Series	PTX-5-100-WDM	See the Hardware Compatibility Tool, <a href="#">PTX-5-100-WDM</a> .
	P1-PTX-2-100G-WDM	See the Hardware Compatibility Tool, <a href="#">P1-PTX-2-100G-WDM</a> .

## Optical Transmit Specifications

The line card is connected using single-mode fiber (SMF) and LC connectors. See [Table 52 on page 117](#) and [Table 53 on page 118](#) for the optical transponder specifications.

**Table 52: QFX10000-6C-DWDM Optical Transmit Specifications**

Specification	Value
Standards compliance	IEEE 802.3 IEC 60825-1 Class 1
Modulation format	DP-QPSK, DP-8QAM, DP-16QAM
Line rate	DP-QPSK = 136.66 Gbps DP-8QAM = 205 Gbps DP-16QAM = 273.33 Gbps
FEC types	SDFEC and SDFEC25 (default)
Channel-plan wavelength range	Extended C-band, 1528.77 nm to 1568.36 nm
Channel-plan frequency range	196.1 THz to 191.35 THz
Channel spacing	0.125 THz
Channel tunability	128 channels. See <a href="#">"1.2-Terabyte Per Second DWDM OTN Module Wavelengths"</a> on page 120.
Optical transmitter output power (on)	-12 to 1.5 dBm, 0.1 dB steps, +/- 1 dB accuracy
Optical transmitter output power (off)	≤ -40 dBM
Optical transmitter wavelength accuracy	+/- 1.8 GHz



**Table 52: QFX10000-6C-DWDM Optical Transmit Specifications (Continued)**

Specification	Value
Optical transmitter channel tuning time	≤ 90 seconds across C-band
TX output power OSNR	≥ 36 dB

## Optical Receive Specifications

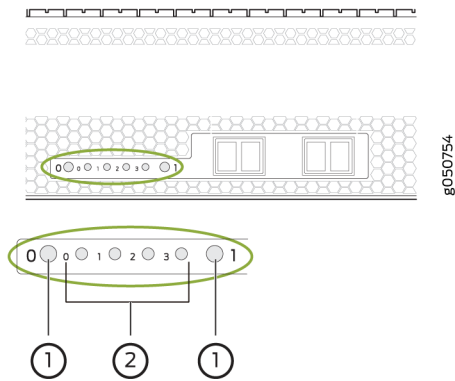
**Table 53: QFX10K-12C-DWDM Optical Receive Specifications**

Specification	100G DP-PSK	150G DP-8QAM	200G DP-16QAM
Optical receiver input power range (low Rx OSNR)	-18 dBm to 0 dBm	-18 dBm to 0 dBm	-18 dBm to 0 dBm
Optical receiver input power range (unamplified / dark fiber applications)	-32 dBm to 0 dBm	-27 dBm to 0 dBm	-25 dBm to 0 dBm
Optical receiver damage input power threshold	+17 dBm	+17 dBm	+17 dBm
Optical receiver minimum OSNR (back-to-back), typical	10.5 dB	15.0 dB	17 dB
Optical receiver minimum OSNR (back-to-back), worst-case, EOL	11.5 dB	16.0 dB	19.0 dB
Optical receiver chromatic dispersion tolerance	+/- 70,000 ps/nm	+/- 45,000 ps/nm	+/- 30,000 ps/nm
Optical receiver PMD tolerance	30 ps mean DGD	20 ps mean DGD	15 ps mean DGD
Optical receiver polarization tracking	100 krad/s	50 krad/s	50 krad/s

### Status and Activity LEDs

There are two kinds of LEDs for the network ports: port LEDs and Ethernet link LEDs. The LEDs for the six physical ports indicate the link state of an OT interface. There are four LEDs in between each port pair that indicate the link state of the associated ET interfaces, see [Figure 66 on page 119](#). To determine the link state of the OT interface, see [Table 54 on page 119](#).

**Figure 66: DWDM Port and Ethernet Link State LEDs**



1– Port LEDs (OT interfaces)

2– Ethernet LEDs (ET interfaces)

**Table 54: Network Port Status LEDs (OT Interfaces)**

Color	Description
Unlit	The port is not configured.
Solid Green	A link is established on the OT interface.
Solid Amber	The optical module associated with the port has a fault condition, or the port is configured but the link is down.

You can also determine the configuration of the ET interfaces by examining the pattern of the 4 Ethernet LEDs. See [Table 55 on page 120](#). To determine the link status and of those ET interfaces see [Table 56 on page 120](#).

**Table 55: Valid ET Interface Link Combinations**

Modulation Format	Aggregate Data Rate	OT Interface Data Rate		ET Interface	Configuration
		Ports 0, 2,	1, 3, 5		
16-QAM (x2)	4 x 100 Gigabit Ethernet	200 Gbps	200 Gbps	0, 1, 2, 3	2 independent 200 Gbps 16-QAM
QPSK and 16-QAM	3 x 100 Gigabit Ethernet	100 Gbps	200 Gbps	0, 2, 3	Independent QPSK and 16-QAM
16-QAM and QPSK	3 x 100 Gigabit Ethernet	200 Gbps	100 Gbps	0, 1, 2	Independent QPSK and 16-QAM
8-QAM	3 x 100 Gigabit Ethernet	150 Gbps	150 Gbps	0, 1, 2	2 Coupled 150 Gbps 8-QAM
QPSK and QPSK	2 x 100 Gigabit Ethernet	100 Gbps	100 Gbps	0,2	Independent 100G QPSK

**Table 56: Ethernet Link LEDs (ET Interfaces)**

Color	Description
Unlit	The ET interface is down.
Solid Green	The ET interface is up but there is no activity.
Blinking Green	The link is up on the ET interface and there is activity.

## 1.2-Terabyte Per Second DWDM OTN Module Wavelengths

The PTX10K-LC1104 coherent line card and the QFX10000-12C-DWDM line card provide six 200-Gbps coherent MACsec ports with built-in long-reach optics. DWDM channel frequency offsets are

0.02 THz. The QFX10000-12C-DWDM line card is available for the QFX10008 and QFX10016 switch chassis running Junos OS Release 17.3R1 and later. The PTX10K-LC1104 coherent line card is available for the PTX10008 and PTX10016 routers. See [Table 57 on page 121](#) for the available channel frequencies and wavelengths.

**Table 57: DWDM Module Wavelengths**

Frequency (THz)	Wavelength (nm)	Offset (GHz)
191.35	1566.72	12.5/50
191.36	1566.62	12.5
191.38	1566.52	12.5
191.39	1566.42	12.5
191.4	1566.31	12.5/50/100
191.41	1566.21	12.5
191.43	1566.11	12.5
191.44	1566.01	12.5
191.45	1565.91	12.5/50
191.46	1565.8	12.5
191.48	1565.7	12.5
191.49	1565.6	12.5
191.5	1565.5	12.5/50/100
191.51	1565.39	12.5

Table 57: DWDM Module Wavelengths (Continued)

Frequency (THz)	Wavelength (nm)	Offset (GHz)
191.53	1565.29	12.5
191.54	1565.19	12.5
191.55	1565.09	12.5/50
191.56	1564.99	12.5
191.58	1564.88	12.5
191.59	1564.78	12.5
191.6	1564.68	12.5/50/100
191.61	1564.58	12.5
191.63	1564.48	12.5
191.64	1564.37	12.5
191.65	1564.27	12.5/50
191.66	1564.17	12.5
191.68	1564.07	12.5
191.69	1563.97	12.5
191.7	1563.86	12.5/50/100

Table 57: DWDM Module Wavelengths (Continued)

Frequency (THz)	Wavelength (nm)	Offset (GHz)
191.71	1563.76	12.5
191.73	1563.66	12.5
191.74	1563.56	12.5
191.75	1563.46	12.5/50
191.76	1563.35	12.5
191.78	1563.25	12.5
191.79	1563.15	12.5
191.8	1563.05	12.5/50/100
191.81	1562.95	12.5
191.83	1562.84	12.5
191.84	1562.74	12.5
191.85	1562.64	12.5/50
191.86	1562.54	12.5
191.88	1562.44	12.5
191.89	1562.33	12.5

Table 57: DWDM Module Wavelengths (Continued)

Frequency (THz)	Wavelength (nm)	Offset (GHz)
191.9	1562.23	12.5/50/100
191.91	1562.13	12.5
191.93	1562.03	12.5
191.94	1561.93	12.5
191.95	1561.83	12.5/50
191.96	1561.72	12.5
191.98	1561.62	12.5
191.99	1561.52	12.5
192	1561.42	12.5/50/100
192.01	1561.32	12.5
192.03	1561.22	12.5
192.04	1561.11	12.5
192.05	1561.01	12.5/50
192.06	1560.91	12.5
192.08	1560.81	12.5

Table 57: DWDM Module Wavelengths (Continued)

Frequency (THz)	Wavelength (nm)	Offset (GHz)
192.09	1560.71	12.5
192.1	1560.61	12.5/50/100
192.11	1560.51	12.5
192.13	1560.4	12.5
192.14	1560.3	12.5
192.15	1560.2	12.5/50
192.16	1560.1	12.5
192.18	1560	12.5
192.188	1559.9	12.5
192.2	1559.79	12.5/50/100
192.21	1559.69	12.5
192.23	1559.59	12.5
192.24	1559.49	12.5
192.25	1559.39	12.5/50
192.26	1559.29	12.5



Table 57: DWDM Module Wavelengths (Continued)

Frequency (THz)	Wavelength (nm)	Offset (GHz)
192.28	1559.19	12.5
192.29	1559.08	12.5
192.3	1558.98	12.5/50/100
192.31	1558.88	12.5
192.33	1558.78	12.5
192.34	1558.68	12.5
192.35	1558.58	12.5/50
192.36	1558.48	12.5
192.38	1558.38	12.5
192.39	1558.27	12.5
192.4	1558.17	12.5/50/100
192.41	1558.07	12.5
192.43	1557.97	12.5
192.44	1557.87	12.5
192.45	1557.77	12.5/50

Table 57: DWDM Module Wavelengths (Continued)

Frequency (THz)	Wavelength (nm)	Offset (GHz)
192.46	1557.67	12.5
192.48	1557.57	12.5
192.49	1557.47	12.5
192.5	1557.36	12.5/50/100
192.51	1557.26	12.5
192.53	1557.16	12.5
192.54	1557.06	12.5
192.55	1556.96	12.5/50
192.56	1556.86	12.5
192.58	1556.76	12.5
192.59	1556.66	12.5
192.6	1556.56	12.5/50/100
192.61	1556.45	12.5
192.63	1556.35	12.5
192.64	1556.25	12.5

Table 57: DWDM Module Wavelengths (Continued)

Frequency (THz)	Wavelength (nm)	Offset (GHz)
192.65	1556.15	12.5/50
192.66	1556.05	12.5
192.68	1555.95	12.5
192.69	1555.85	12.5
192.7	1555.75	12.5/50/100
192.71	1555.65	12.5
192.73	1555.55	12.5
192.74	1555.44	12.5
192.75	1555.34	12.5/50
192.76	1555.24	12.5
192.78	1555.14	12.5
192.79	1555.04	12.5
192.8	1554.94	12.5/50/100
192.81	1554.84	12.5
192.83	1554.74	12.5

Table 57: DWDM Module Wavelengths (Continued)

Frequency (THz)	Wavelength (nm)	Offset (GHz)
192.84	1554.64	12.5
192.85	1554.54	12.5/50
192.86	1554.44	12.5
192.88	1554.34	12.5
192.89	1554.24	12.5
192.9	1554.13	1554.134
192.91	1554.03	12.5
192.93	1553.93	12.5
192.94	1553.83	12.5
192.95	1553.73	12.5/50
192.96	1553.63	12.5
192.98	1553.53	12.5
192.99	1553.43	12.5
193	1553.33	12.5/50/100
193.01	1553.23	12.5

Table 57: DWDM Module Wavelengths (Continued)

Frequency (THz)	Wavelength (nm)	Offset (GHz)
193.03	1553.13	12.5
193.04	1553.03	12.5
193.05	1552.93	12.5/50
193.06	1552.83	12.5
193.08	1552.73	12.5
193.09	1552.63	12.5
193.1	1552.52	12.5/50/100
193.11	1552.42	12.5
193.13	1552.32	12.5
193.14	1552.22	12.5
193.15	1552.12	12.5/50
193.16	1552.02	12.5
193.18	1551.92	12.5
193.19	1551.82	12.5
193.2	1551.72	12.5/50/100

Table 57: DWDM Module Wavelengths (Continued)

Frequency (THz)	Wavelength (nm)	Offset (GHz)
193.21	1551.62	12.5
193.23	1551.52	12.5
193.24	1551.42	12.5
193.25	1551.32	12.5/50
193.26	1551.22	12.5
193.28	1551.12	12.5
193.29	1551.02	12.5
193.3	1550.92	12.5/50/100
193.31	1550.82	12.5
193.33	1550.72	12.5
193.34	1550.62	12.5
193.35	1550.52	12.5/50
193.36	1550.42	12.5
193.38	1550.32	12.5
193.39	1550.22	12.5

Table 57: DWDM Module Wavelengths (Continued)

Frequency (THz)	Wavelength (nm)	Offset (GHz)
193.4	1550.12	12.5/50/100
193.41	1550.02	12.5
193.43	1549.92	12.5
193.44	1549.82	12.5
193.45	1549.72	12.5/50
193.46	1549.62	12.5
193.48	1549.52	12.5
193.49	1549.42	12.5
193.5	1549.32	12.5/50/100
193.51	1549.22	12.5
193.53	1549.12	12.5
193.54	1549.02	12.5
193.55	1548.92	12.5/50
193.56	1548.82	12.5
193.58	1548.72	12.5

Table 57: DWDM Module Wavelengths (Continued)

Frequency (THz)	Wavelength (nm)	Offset (GHz)
193.59	1548.62	12.5
193.6	1548.52	12.5/50/100
193.61	1548.42	12.5
193.63	1548.32	12.5
193.64	1548.22	12.5
193.65	1548.12	12.5/50
193.66	1548.02	12.5
193.68	1547.92	12.5
193.69	1547.82	12.5
193.7	1547.72	12.5/50/100
193.71	1547.62	12.5
193.73	1547.52	12.5
193.74	1547.42	12.5
193.75	1547.32	12.5/50
193.76	1547.22	12.5



Table 57: DWDM Module Wavelengths (Continued)

Frequency (THz)	Wavelength (nm)	Offset (GHz)
193.78	1547.12	12.5
193.79	1547.02	12.5
193.8	1546.92	12.5/50/100
193.81	1546.82	12.5
193.83	1546.72	12.5
193.84	1546.62	12.5
193.85	1546.52	12.5/50
193.86	1546.42	12.5
193.88	1546.32	12.5
193.89	1546.22	12.5
193.9	1546.12	12.5/50/100
193.91	1546.02	12.5
193.93	1545.92	12.5
193.94	1545.82	12.5
193.95	1545.72	12.5/50

Table 57: DWDM Module Wavelengths (Continued)

Frequency (THz)	Wavelength (nm)	Offset (GHz)
193.96	1545.62	12.5
193.98	1545.52	12.5
193.99	1545.42	12.5
194	1545.32	12.5/50/100
194.01	1545.22	12.5
194.03	1545.12	12.5
194.04	1545.02	12.5
194.05	1544.92	12.5/50
194.06	1544.82	12.5
194.08	1544.73	12.5
194.09	1544.63	12.5
194.1	1544.53	12.5/50/100
194.11	1544.43	12.5
194.13	1544.33	12.5
194.14	1544.23	12.5

Table 57: DWDM Module Wavelengths (Continued)

Frequency (THz)	Wavelength (nm)	Offset (GHz)
194.15	1544.13	12.5/50
194.16	1544.03	12.5
194.18	1543.93	12.5
194.19	1543.83	12.5
194.2	1543.73	12.5/50/100
194.21	1543.63	12.5
194.23	1543.53	12.5
194.24	1543.43	12.5
194.25	1543.33	12.5/50
194.26	1543.23	12.5
194.28	1543.14	12.5
194.29	1543.04	12.5
194.3	1542.94	12.5/50/100
194.31	1542.84	12.5
194.33	1542.74	12.5

Table 57: DWDM Module Wavelengths (Continued)

Frequency (THz)	Wavelength (nm)	Offset (GHz)
194.34	1542.64	12.5
194.35	1542.54	12.5/50
194.36	1542.44	12.5
194.38	1542.34	12.5
194.39	1542.24	12.5
194.4	1542.14	12.5/50/100
194.41	1542.04	12.5
194.43	1541.94	12.5
194.44	1541.85	12.5
194.45	1541.75	12.5/50
194.46	1541.65	12.5
194.48	1541.55	12.5
194.49	1541.45	12.5
194.5	1541.35	12.5/50/100
194.51	1541.25	12.5

Table 57: DWDM Module Wavelengths (Continued)

Frequency (THz)	Wavelength (nm)	Offset (GHz)
194.53	1541.15	12.5
194.54	1541.05	12.5
194.55	1540.95	12.5/50
194.56	1540.85	12.5
194.58	1540.76	12.5
194.59	1540.66	12.5
194.6	1540.56	12.5/50/100
194.61	1540.46	12.5
194.63	1540.36	12.5
194.64	1540.26	12.5
194.65	1540.16	12.5/50
194.66	1540.06	12.5
194.68	1539.96	12.5
194.69	1539.87	12.5
194.7	1539.77	12.5/50/100

Table 57: DWDM Module Wavelengths (Continued)

Frequency (THz)	Wavelength (nm)	Offset (GHz)
194.71	1539.67	12.5
194.73	1539.57	12.5
194.74	1539.47	12.5
194.75	1539.37	12.5/50
194.76	1539.27	12.5
194.78	1539.17	12.5
194.79	1539.07	12.5
194.8	1538.98	12.5/50/100
194.81	1538.88	12.5
194.83	1538.78	12.5
194.84	1538.68	12.5
194.85	1538.58	12.5/50
194.86	1538.48	12.5
194.88	1538.38	12.5
194.89	1538.29	12.5

Table 57: DWDM Module Wavelengths (Continued)

Frequency (THz)	Wavelength (nm)	Offset (GHz)
194.9	1538.19	12.5/50/100
194.91	1538.09	12.5
194.93	1537.99	12.5
194.94	1537.89	12.5
194.95	1537.79	12.5/50
194.96	1537.69	12.5
194.98	1537.59	12.5
194.99	1537.5	12.5
195	1537.4	12.5/50/100
195.01	1537.3	12.5
195.03	1537.2	12.5
195.04	1537.1	12.5
195.05	1537	12.5/50
195.06	1536.9	12.5
195.08	1536.8	12.5

Table 57: DWDM Module Wavelengths (*Continued*)

Frequency (THz)	Wavelength (nm)	Offset (GHz)
195.09	1536.7	12.5
195.1	1536.6	12.5/50/100
195.11	1536.51	12.5
195.13	1536.41	12.5
195.14	1536.31	12.5
195.15	1536.22	12.5/50
195.16	1536.12	12.5
195.18	1536.02	12.5
195.19	1535.92	12.5
195.2	1535.82	12.5/50/100
195.21	1535.72	12.5
195.23	1535.63	12.5
195.24	1535.53	12.5
195.25	1535.43	12.5/50
195.26	1535.33	12.5



Table 57: DWDM Module Wavelengths (Continued)

Frequency (THz)	Wavelength (nm)	Offset (GHz)
195.28	1535.23	12.5
195.29	1535.13	12.5
195.3	1535.03	12.5/50/100
195.31	1534.94	12.5
195.33	1534.84	12.5
195.34	1534.74	12.5
195.35	1564.64	12.5/50
195.36	1534.55	12.5
195.38	1534.45	12.5
195.39	1534.35	12.5
195.4	1534.25	12.5/50/100
195.41	1534.15	12.5
195.43	1534.05	12.5
195.44	1533.96	12.5
195.45	1533.86	12.5/50

Table 57: DWDM Module Wavelengths (Continued)

Frequency (THz)	Wavelength (nm)	Offset (GHz)
195.46	1533.76	12.5
195.48	1533.66	12.5
195.49	1533.56	12.5
195.5	1533.47	12.5/50/100
195.51	1533.37	12.5
195.53	1533.27	12.5
195.54	1533.17	12.5
195.55	1533.07	12.5/50
195.56	1532.98	12.5
195.58	1532.88	12.5
195.59	1532.78	12.5
195.6	1532.68	12.5/50/100
195.61	1532.58	12.5
195.63	1532.49	12.5
195.64	1532.39	12.5

Table 57: DWDM Module Wavelengths (Continued)

Frequency (THz)	Wavelength (nm)	Offset (GHz)
195.65	1532.29	12.5/50
195.66	1532.19	12.5
195.68	1532.09	12.5
195.69	1532	12.5
195.7	1531.9	12.5/50/100
195.71	1531.8	12.5
195.73	1531.7	12.5
195.74	1531.61	12.5
185.75	1531.51	12.5/50
185.76	1531.41	12.5
195.78	1531.31	12.5
195.79	1531.21	12.5
195.8	1531.12	12.5/50/100
195.81	1531.02	12.5
195.83	1530.92	12.5

Table 57: DWDM Module Wavelengths (Continued)

Frequency (THz)	Wavelength (nm)	Offset (GHz)
195.84	1530.82	12.5
195.85	1530.73	12.5/50
195.86	1530.63	12.5
195.88	1530.53	12.5
195.89	1530.43	12.5
195.9	1530.33	12.5/50/100
195.91	1530.34	12.5
195.93	1530.24	12.5
195.94	1530.04	12.5
195.95	1529.94	12.5/50
195.96	1529.85	12.5
195.98	1529.75	12.5
195.99	1529.65	12.5
196	1529.55	12.5/50/100
196.01	1529.46	12.5

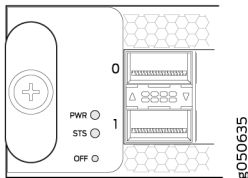
Table 57: DWDM Module Wavelengths (Continued)

Frequency (THz)	Wavelength (nm)	Offset (GHz)
196.03	1529.36	12.5
196.04	1529.26	12.5
196.05	1529.16	12.5/50
196.06	1529.07	12.5
196.08	1528.97	12.5
196.09	1528.87	12.5
196.1	1528.77	12.5/50/100

## QFX10000 Line Card LEDs

All QFX10000 line cards have three bi-colored LEDs (see [Figure 67 on page 146](#)).

Figure 67: Line Card LEDs



[Table 58 on page 147](#) describes the functions of the line card LEDs.

Table 58: Power and Status LEDs

Label	Color	State	Description
PWR	Green	On steadily	The line card is receiving power.
	Yellow	Blinking	The line card has a power error, such as insufficient power.
	Unlit	Off	The line card is not receiving power.
STS	Green	On steadily	The line card is online and functioning normally.
	Green	Blinking	The beacon feature is enabled on the line card.
	Yellow	On steadily	The line card is booting.
	Yellow	Blinking	The line card is detecting an error.
	Unlit	Off	The line card is offline.
OFF	Green	On steadily	The line card is offline.

## Offline Button

The offline/online button is recessed below the faceplate directly below the status (STS) LED. You can take any QFX10000 offline or online by using either of these two methods:

- Press the **OFF** button with a non-conductive pin tool, such as a toothpick, until the **STS** LED goes out (about 5 seconds).
- Issue the CLI command:

```
user@host> request chassis pic fpc-slot fpc-slot pic-slot pic-slot offline
```

## RELATED DOCUMENTATION

[Maintaining QFX10000 Line Cards | 309](#)

*Channelizing Interfaces on QFX3500, QFX3600, QFX5100, QFX10002, QFX10008, QFX10016, and EX4600 Switches*

# 2

CHAPTER

## Site Planning, Preparation, and Specifications

---

QFX10008 Site Preparation Checklist | 150

QFX10008 Site Guidelines and Requirements | 151

QFX10008 Power Planning | 163

QFX10000 Transceiver and Cable Specifications | 171

QFX10000 Console and Management Cable Specifications and Pinouts | 179

---



# QFX10008 Site Preparation Checklist

The checklist in [Table 59 on page 150](#) summarizes the tasks you need to perform when preparing a site for a QFX10008 chassis installation.

**Table 59: Site Preparation Checklist**

✓	Item or Task	For More Information
<b>Environment</b>		
□	Verify that environmental factors such as temperature and humidity do not exceed router tolerances.	<a href="#">"QFX10000 Environmental Requirements and Specifications" on page 152</a>
<b>Power</b>		
□	Measure the distance between external power sources and the router installation site.	
□	Calculate the power consumption and requirements.	<a href="#">"QFX10008 Power Planning" on page 163</a>
<b>Rack</b>		
□	Verify that your rack meets the minimum requirements for the installation of the router.	<a href="#">"QFX10000 Rack Requirements" on page 155</a>
□	Plan rack location, including required space clearances.	<a href="#">"QFX10000 Clearance Requirements for Airflow and Hardware Maintenance" on page 158</a>
□	Secure the rack to the floor and building structure.	
<b>Cables</b>		

Table 59: Site Preparation Checklist (*Continued*)

✓	Item or Task	For More Information
□	Acquire cables and connectors: <ul style="list-style-type: none"> <li>• Determine the number of cables needed based on your planned configuration.</li> <li>• Review the maximum distance allowed for each cable. Choose the length of cable based on the distance between the hardware components being connected.</li> </ul>	The list of supported transceivers for the QFX10008 line cards is located at <a href="https://pathfinder.juniper.net/hct/product/#prd=QFX10008">https://pathfinder.juniper.net/hct/product/#prd=QFX10008</a> .
□	Plan the cable routing and management.	
□	<b>Hardware Upgrades</b>	Order individual components. See "QFX10008 Configurations and Upgrade Options" on page 14.

## RELATED DOCUMENTATION

*General Safety Guidelines and Warnings*

*General Site Guidelines*

[QFX10008 Installation Overview | 186](#)

# QFX10008 Site Guidelines and Requirements

## IN THIS SECTION

- [QFX10000 Environmental Requirements and Specifications | 152](#)
- [General Site Guidelines | 153](#)
- [Site Electrical Wiring Guidelines | 154](#)
- [QFX10000 Rack Requirements | 155](#)
- [QFX10000 Clearance Requirements for Airflow and Hardware Maintenance | 158](#)

## QFX10000 Environmental Requirements and Specifications

The QFX10008 and QFX10016 modular switches must be installed in a four-post rack. It must be housed in a dry, clean, well-ventilated, and temperature-controlled environment.

Follow these environmental guidelines:

- The site must be as dust-free as possible, because dust can clog air intake vents and filters, reducing the efficiency of the switch cooling system.
- Maintain ambient airflow for normal switch operation. If the airflow is blocked or restricted, or if the intake air is too warm, the switch might overheat, leading to the switch temperature monitor shutting down the device to protect the hardware components.

[Table 60 on page 152](#) provides the required environmental conditions for normal switch operation.

**Table 60: QFX10000 Environmental Tolerances**

Description	Tolerance
Altitude	No performance degradation to 6562 feet (2000 meters).
Relative humidity	<p>Normal operation ensured in relative humidity range of 5% through 90%, noncondensing.</p> <ul style="list-style-type: none"> <li>• Short-term operation ensured in relative humidity range of 5% through 93%, noncondensing.</li> </ul> <p><b>NOTE:</b> As defined in NEBS GR-63-CORE, Issue 3, short-term events can be up to 96 hours in duration but not more than 15 days per year.</p>

Table 60: QFX10000 Environmental Tolerances (*Continued*)

Description	Tolerance
Temperature	<ul style="list-style-type: none"> <li>Normal operation ensured in temperature range of 32° F through 104° F (0° C through 40° C).</li> </ul> <p><b>NOTE:</b> Ensure the room temperature does not increase or decrease more than 2° C per minute.</p> <ul style="list-style-type: none"> <li>Nonoperating storage temperature in shipping container: -40° F through 158° F (-40° C through 70° C).</li> </ul>
Seismic	Designed to comply with Zone 4 earthquake requirements per NEBS GR-63-CORE, Issue 3.

**NOTE:** Install QFX10008 and QFX10016 modular switches only in restricted areas, such as dedicated equipment rooms and equipment closets, in accordance with Articles 110-16, 110-17, and 110-18 of the National Electrical Code, ANSI/NFPA 70.

## SEE ALSO

[QFX10008 Installation Overview | 186](#)

[QFX10016 Installation Overview](#)

## General Site Guidelines

Efficient device operation requires proper site planning and maintenance. It also requires proper layout of the equipment, rack or cabinet, and wiring closet.

To plan and create an acceptable operating environment for your device and prevent environmentally caused equipment failures:

- Keep the area around the chassis free from dust and conductive material, such as metal flakes.
- Follow the prescribed airflow guidelines to ensure that the cooling system functions properly. Ensure that exhaust from other equipment does not blow into the intake vents of the device.

- Follow the prescribed electrostatic discharge (ESD) prevention procedures to prevent damaging the equipment. Static discharge can cause components to fail completely or intermittently over time.
- Install the device in a secure area, so that only authorized personnel can access the device.

## Site Electrical Wiring Guidelines

Table 61 on page 154 describes the factors you must consider while planning the electrical wiring at your site.



**WARNING:** You must provide a properly grounded and shielded environment and use electrical surge-suppression devices.

**Avertissement** Vous devez établir un environnement protégé et convenablement mis à la terre et utiliser des dispositifs de parasurtension.

**Table 61: Site Electrical Wiring Guidelines**

Site Wiring Factor	Guidelines
Signaling limitations	<p>If your site experiences any of the following problems, consult experts in electrical surge suppression and shielding:</p> <ul style="list-style-type: none"> <li>• Improperly installed wires cause radio frequency interference (RFI).</li> <li>• Damage from lightning strikes occurs when wires exceed recommended distances or pass between buildings.</li> <li>• Electromagnetic pulses (EMPs) caused by lightning damage unshielded conductors and electronic devices.</li> </ul>
Radio frequency interference	<p>To reduce or eliminate RFI from your site wiring, do the following:</p> <ul style="list-style-type: none"> <li>• Use a twisted-pair cable with a good distribution of grounding conductors.</li> <li>• If you must exceed the recommended distances, use a high-quality twisted-pair cable with one ground conductor for each data signal, when applicable.</li> </ul>

**Table 61: Site Electrical Wiring Guidelines (Continued)**

Site Wiring Factor	Guidelines
Electromagnetic compatibility	<p>If your site is susceptible to problems with electromagnetic compatibility (EMC), particularly from lightning or radio transmitters, seek expert advice.</p> <p>Strong sources of electromagnetic interference (EMI) can cause:</p> <ul style="list-style-type: none"> <li>• Destruction of the signal drivers and receivers in the device</li> <li>• Electrical hazards as a result of power surges conducted over the lines into the equipment.</li> </ul>

## QFX10000 Rack Requirements

The QFX10000 modular switch chassis are designed to be installed in four-post racks.

Rack requirements consist of:

- Rack type
- Rack mount kit hole spacing
- Rack size and strength
- Rack connection to the building structure

[Table 62 on page 156](#) provides the rack requirements and specifications for the QFX10008 and the QFX10016.

Table 62: Rack Requirements for the QFX10000

Rack Requirement	Guidelines
Rack type: four-post	<p>Use a four-post rack that provides bracket holes or hole patterns spaced at 1 U (1.75 in. or 4.45 cm) increments and that meets the size and strength requirements to support the weight.</p> <p>A U is the standard rack unit defined in <i>Cabinets, Racks, Panels, and Associated Equipment</i> (document number EIA-310-D) published by the Electronics Industry Association.</p> <p>You can stack two QFX10016 or three QFX10008 chassis in a four-post rack if:</p> <ul style="list-style-type: none"> <li>• The rack is 42 U or greater.</li> <li>• The rack meets the strength requirements to support the weight.</li> <li>• The facility can provide adequate power and cooling.</li> </ul>
Rack mount kit hole spacing	<p>The holes in the rack mount kit are spaced at 1 U (1.75 in. or 4.45 cm), so that the switch can be mounted in any rack that provides holes spaced at that distance.</p>

Table 62: Rack Requirements for the QFX10000 (Continued)

Rack Requirement	Guidelines
Rack size and strength	<ul style="list-style-type: none"> <li>• Ensure that the rack complies with the standards for a 19-in. wide rack as defined in <i>Cabinets, Racks, Panels, and Associated Equipment</i> (document number EIA-310-D) published by the Electronics Industry Association.</li> <li>• Use one of the standard rack lengths as defined in the four-part <i>Equipment Engineering (EE); European telecommunications standard for equipment practice</i> (document numbers ETS 300 119-1 through 119-4) published by the European Telecommunications Standards Institute. <ul style="list-style-type: none"> <li>• 23.62 in. (600 mm)</li> <li>• 30.0 in. (762 mm)</li> <li>• 31.5 in. (800 mm)</li> </ul> </li> <li>• Ensure that the rack rails are spaced widely enough to accommodate the switch chassis' external dimensions. The outer edges of the flanges, attached to the chassis, extend the chassis width to 19 in. (48.26 cm).</li> <li>• Ensure that the rack is strong enough to support the weight of the switch and cabling.</li> <li>• Ensure that the spacing of rails and adjacent racks allows for proper clearance around the switch and rack. .</li> </ul>
Rack connection to building structure	<ul style="list-style-type: none"> <li>• Secure the rack to the building structure.</li> <li>• If earthquakes are a possibility in your geographical area, secure the rack to the floor.</li> <li>• Secure the rack to the ceiling as well as wall or floor for maximum stability.</li> </ul>

**SEE ALSO**

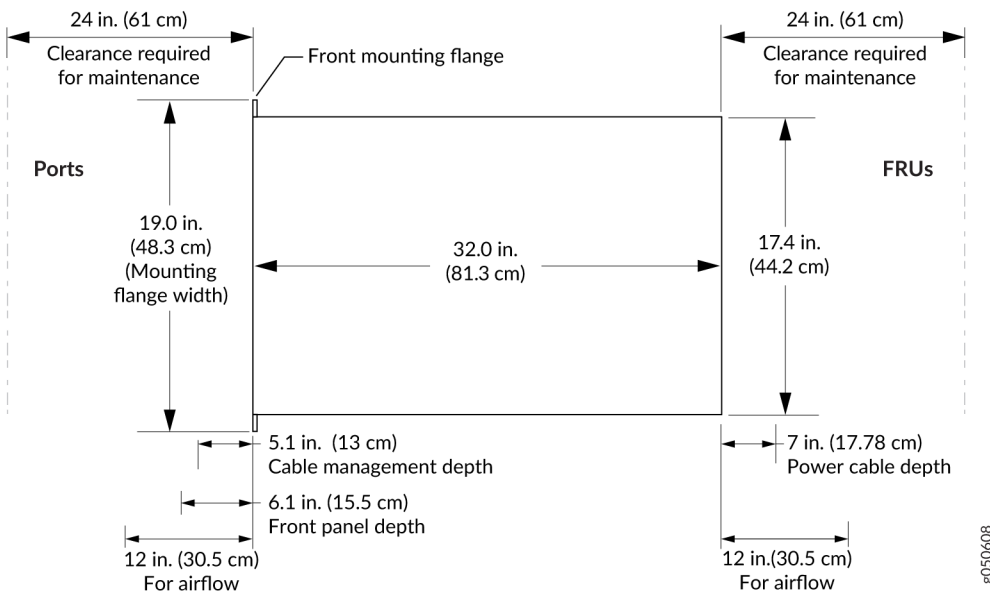
*Rack-Mounting and Cabinet-Mounting Warnings*



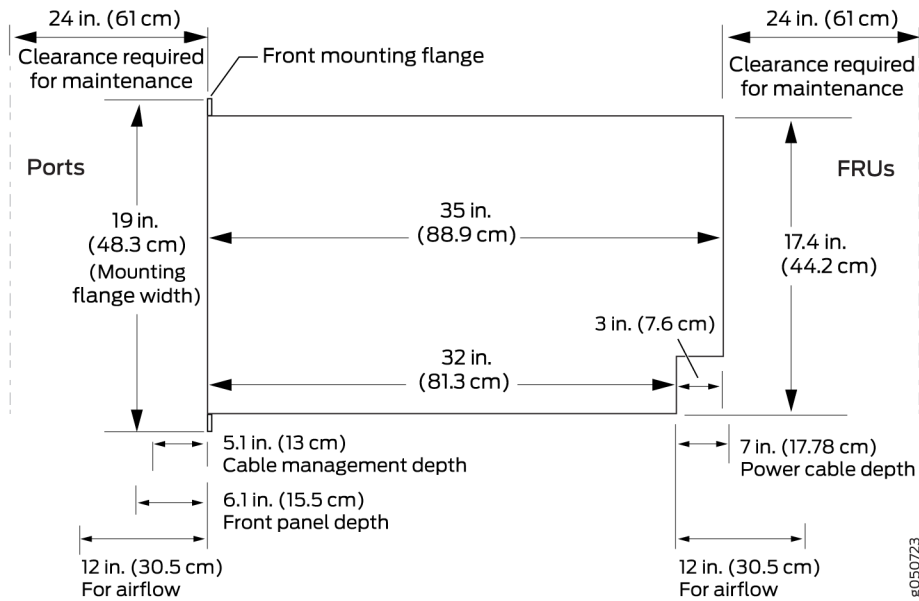
## QFX10000 Clearance Requirements for Airflow and Hardware Maintenance

When planning the site for a QFX10008 or QFX10016 installation, you must allow sufficient clearance around the installed chassis for cooling and maintenance (see [Figure 68 on page 158](#) for QFX10008 and [Figure 69 on page 159](#) for QFX100016).

**Figure 68: Clearance Requirements for Airflow and Hardware Maintenance for a QFX10008 Modular Chassis**



**Figure 69: Clearance Requirements for Airflow and Hardware Maintenance for a QFX10016 Modular Chassis**



Follow these guidelines:

- For the cooling system to function properly, the airflow around the chassis must be unrestricted.
- If you are mounting a QFX10000 in a rack with other equipment, ensure that the exhaust from other equipment does not blow into the intake vents of the chassis.
- Leave at least 24 in. (61 cm) both in front of and behind the QFX10000 for service personnel to remove and install hardware components. To be NEBS GR-63 compliant, allow at least 30 in. (76.2 cm) in front of the rack and 24 in. (61 cm) behind the rack.

## SEE ALSO

*Rack-Mounting and Cabinet-Mounting Warnings*

## QFX10008 Chassis Physical Specifications

The QFX10008 modular chassis is a rigid sheet-metal structure that houses the other switch components. You can mount up to three QFX10008 chassis in a standard 19-in. 4-post rack (42 U) rack provided the rack can handle the combined weight and there is adequate power and cooling. [Table 63 on page 160](#) summarizes the physical specifications of the chassis. See [Figure 70 on page 162](#).

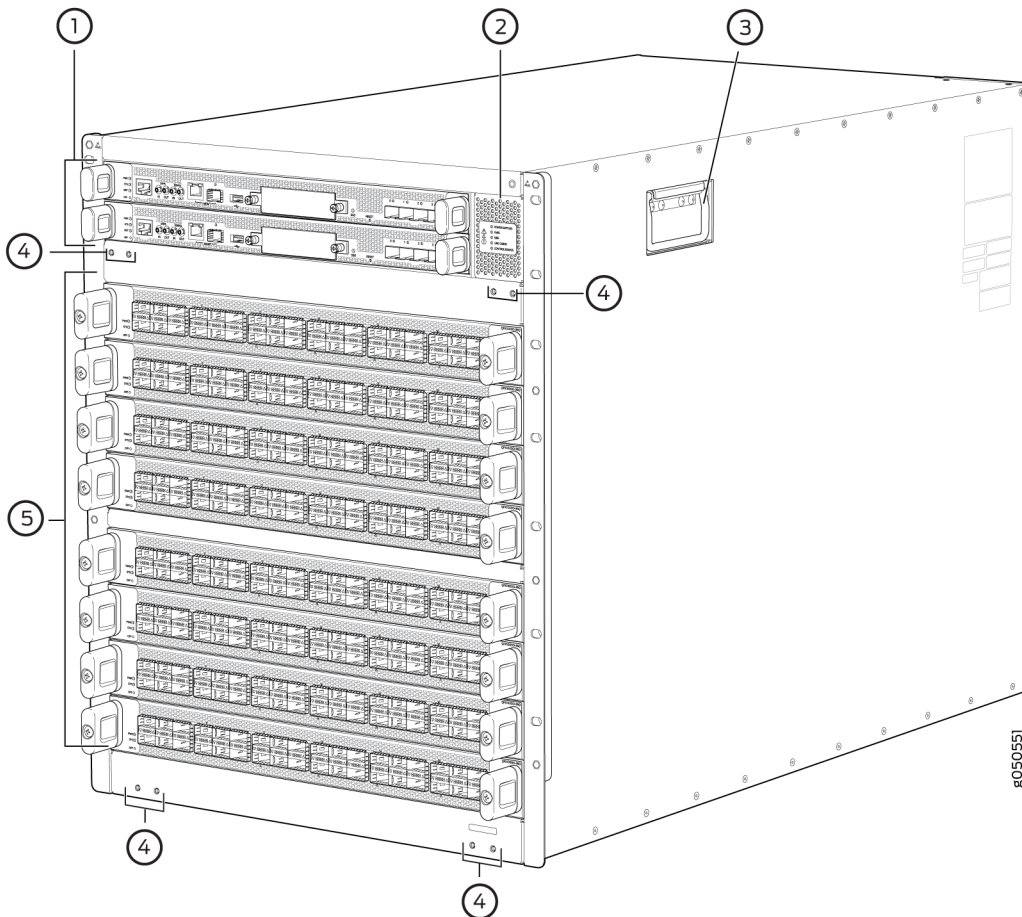
Table 63: QFX10008 Physical Specifications

Description	Weight	Height	Width	Depth
Chassis, spare	145.2 lb (65.86 kg)	22.6 in. (57.4 cm)	17.4 in. (44.2 cm) <b>NOTE:</b> The outer edges of the mounting-bracket flange extend the width to 19 in. (48.3 cm).	32 in. (81.28 cm)
Chassis base AC configuration  Includes 1 RCB, 3 QFX10000-PWR-AC power supplies, 2 QFX10008-FAN fan trays, 2 QFX10008-FAN-CTRL fan tray controllers, and 5 Switch Interface Boards (SIBs)	280 lb (127 kg)	22.6 in. (57.4 cm)	17.4 in. (44.2 cm) <b>NOTE:</b> The outer edges of the mounting-bracket flange extend the width to 19 in. (48.3 cm).	32 in. (81.28 cm)
Chassis redundant AC configuration  Includes 2 RCBs, 6 QFX10000-PWR-AC power supplies, QFX10008-FAN fan trays, 2 QFX10008-FAN-CTRL fan tray controllers, and 6 SIBs	322 lb (146.06 kg)	22.6 in. (57.4 cm)	17.4 in. (44.2 cm) <b>NOTE:</b> The outer edges of the mounting-bracket flange extend the width to 19 in. (48.3 cm).	32 in. (81.28 cm)
Chassis redundant DC configuration  Includes 2 RCBs, 6 QFX10000-PWR-DC power supplies, QFX10008-FAN fan trays, 2 QFX10008-FAN-CTRL fan tray controllers, and 6 SIBs	319 lb (144.7 kg)	22.6 in. (57.4 cm)	17.4 in. (44.2 cm) <b>NOTE:</b> The outer edges of the mounting-bracket flange extend the width to 19 in. (48.3 cm).	32 in. (81.28 cm)
QFX10000-30C Line Card	27 lb (12.2 kg)	1.89 in. (4.8 cm)	17.2 in. (43.7 cm)	20.54 in. (52.2 cm)

**Table 63: QFX10008 Physical Specifications (Continued)**

Description	Weight	Height	Width	Depth
QFX10000-30C-M Line Card	28.5 lb (12.9 kg)	1.89 in. (4.8 cm)	17.2 in. (43.7 cm)	20.54 in. (52.2 cm)
QFX10000-36Q Line Card	22.6 lb (10.2 kg)	1.89 in. (4.8 cm)	17.2 in. (43.7 cm)	20.54 in. (52.2 cm)
QFX10000-60S-6Q Line Card	21.4 lb (9.7 kg)	1.89 in. (4.8 cm)	17.2 in. (43.7 cm)	20.54 in. (52.2 cm)
QFX10K-12C-DWDM	31 lb (14.06 kg)	1.89 in. (4.8 cm)	17.2 in. (43.7 cm)	20.54 in. (52.2 cm)

Figure 70: Front View of QFX10008



1– Control boards

2– Status panel

3– Handles

4– Mounting holes for front panel

5– Line cards



**WARNING:** The handles on each side of the chassis facilitate the fine-tune positioning of the chassis on the mounting brackets. Do not use the handles to lift the chassis, even when the chassis is empty. See "[Installing the QFX10008 into a Rack](#)" on page 200 for instructions for properly moving a loaded chassis.

## SEE ALSO

[QFX10008 Configurations and Upgrade Options](#) | 14

[QFX10008 Cooling System and Airflow](#) | 32

## RELATED DOCUMENTATION

[QFX10000 Rack Requirements](#) | 155

# QFX10008 Power Planning

## IN THIS SECTION

- [Power Requirements for QFX10000 Components](#) | 163
- [Calculating Power Requirements for a QFX10008](#) | 165
- [QFX10008 and QFX10016 Grounding Cable and Lug Specifications](#) | 170

Use the information to calculate the power consumption for the QFX10008 and plan your configuration's power requirements.

## Power Requirements for QFX10000 Components

[Table 64 on page 163](#) lists the power requirements for different hardware components of a QFX10008 and QFX10016 under typical voltage conditions. For power requirements for chassis configurations, see "[Calculating Power Requirements for a QFX10008](#)" on page 165 and [Calculating Power Requirements for a QFX10016](#).

**Table 64: Power Requirements for QFX10000 Components**

Components	Description	Power Requirements (Watts)	
		Typical Power	Maximum Power
QFX10008-SF	QFX10008 SIB	170 W	225 W
QFX10016-SF	QFX10016 SIB	510 W	675 W

Table 64: Power Requirements for QFX10000 Components (Continued)

Components	Description	Power Requirements (Watts)	
		Typical Power	Maximum Power
QFX10008-FAN	QFX10008 standard fan tray	225 W at 77° F (25° C)	475 W at maximum fan speed
QFX10016-FAN	QFX10016 fan tray	475 W at 77° F (25° C)	975 W at maximum fan speed
QFX10000-RE	QFX10000 Routing and Control Board	50 W	125 W
QFX10000-30C	QFX10000 30-port QSFP28 line card	890 W	1150 W
QFX10000-30C-M	QFX10000 30-port MACsec QSSP28 line card	950 W	1250 W
QFX10000-36Q	QFX10000 36-port QSFP+ line card	520 W	675 W
QFX10000-60S-6Q	QFX10000 60-port SFP+ and 6-port QSFP+ line card	365 W	455 W
QFX10K-12C-DWDM	QFX10000 Coherent line card	900 W	1050 W

## Calculating Power Requirements for a QFX10008

### IN THIS SECTION

- [How to Calculate the Power Consumption of Your QFX10008 | 166](#)
- [How to Calculate the Number of Power Supplies Required for Your QFX10008 | 168](#)

Use the information in this topic to calculate power requirements of your QFX10008 configuration and the number of power supplies required for different QFX10008 switch configurations.



**CAUTION:** To ensure adequate power and to avoid raising a power alarm, you must maintain a redundant power supply in your device at all times. This additional power supply provides for the recommended  $n+1$  redundancy.

Replace failed power supplies immediately to prevent unexpected failures.

If a new line card is installed in an operational switch, power management does not power on the line card if the increased power demand exceeds the total available power, including redundant power. If redundant power is used to power on the line card, a minor alarm is raised, which becomes a major alarm in five minutes if the condition is not corrected.

**NOTE:** The calculations in this topic represent the maximum power requirements that you need to budget for your QFX10008 modular switch configuration. The actual power consumption of your switch will be less than the calculated results shown here and will vary based on the hardware and software configuration of your switch, the amount of traffic passing through the line cards, and environmental variables such as room temperature.

Before you begin these calculations:

- Ensure you understand the different switch configurations. See "[QFX10008 Configurations and Upgrade Options](#)" on page 14.
- Ensure that you know the power requirements of different switch components. See "[Power Requirements for QFX10000 Components](#)" on page 163.

This topic describes these tasks:



## How to Calculate the Power Consumption of Your QFX10008

Use the following procedure to determine the maximum power you need to supply to the switch. To calculate maximum system power consumption, you first determine the combined maximum internal power requirements of all the switch components and then divide this result by the power supply output power.

To calculate maximum system power consumption:

1. Determine the maximum power consumption of the base chassis components (that is, the components other than the line cards). Use Table 2 if your switch is configured as either one of the base or redundant configurations.

**Table 65: Chassis Power Consumption for Standard Configurations**

Chassis Component	Base Configuration or Base HVAC/HVDC Configuration	Redundant Configuration or HVAC/HVDC Configuration
QFX10008-FAN	950 W	950 W
QFX10000-RE	125 W	250 W
QFX10008-SF	1125 W	1350 W
<b>Total</b>	<b>2220 W</b>	<b>2550 W</b>

2. Calculate the maximum internal power consumption of the entire switch by adding in the power requirements of each line card. See Table 3 for a chart of the power needed for line cards.

**Table 66: Line Card Power Consumption**

Number of Line Cards	QFX10000-36Q	QFX10000-30C	QFX10000-30C-M	QFX10000-60S-6Q	QFX10000-12C-DWDM
1	675 W	1150 W	1250 W	455 W	1050 W
2	1350 W	2300 W	2500 W	910 W	2100 W
3	2025 W	3450 W	3750 W	1365 W	3150 W

Table 66: Line Card Power Consumption (Continued)

Number of Line Cards	QFX10000-36Q	QFX10000-30C	QFX10000-30C-M	QFX10000-60S-6Q	QFX10000-12C-DWDM
4	2700 W	4600 W	5000 W	1820 W	4200 W
5	3375 W	5750 W	6250 W	2275 W	—
6	4050 W	6900 W	7500 W	2730 W	—
7	4725 W	8050 W	8750 W	3185 W	—
8	5400 W	9200 W	10000 W	3640 W	—

**NOTE:** The QFX10000-12C-DWDM line card is designed to comply with NEBS regulations on the QFX10000 line of modular switch chassis when these switches are used in typical configurations. In a typical configuration, a QFX10008 switch supports up to eight line cards, with up to four QFX10000-12C-DWDM in any of the eight slots.

To comply with EMC regulations, you must also install front panel on the QFX10008 chassis. See "[QFX10000 EMI Front Panel](#)" on page 27.

For example, for a QFX10008 with five QFX10000-36Q line cards and three QFX10000-30C, the maximum power consumption is:

= 5 (power consumed by QFX10000-36Q in watts) + 3 (power consumed by QFX10000-30C line cards in watts)

= 5 (675 W) + 3 (1150 W)

= (3375 W + 3450 W)

= 6825 W

3. Add the power consumption from Step 1 and the total line card consumption from Step 2.

To continue from the previous example, add the wattage from five QFX10000-36Q and three QFX10000-30C cards to a redundant configuration.

(6825 W) + (2550 W)

= 9375 W required

## How to Calculate the Number of Power Supplies Required for Your QFX10008

Use this procedure to calculate the number of power supplies required by your switch configuration. The minimum power configuration for QFX10008 switches is three power supplies. However, using the calculated minimum power configuration does not prevent the system from raising a power alarm. To ensure you do not log power alarms, you must configure your router for  $n+1$  power supplies.

To calculate the number of power supplies required for your minimum switch configuration:

1. Determine the power available from the power supplies. [Table 67 on page 168](#) shows the power available for installed power supplies.

**NOTE:** DC systems are only supported in the redundant configuration.

**Table 67: Total Power Available**

Power Supply Module Models	With Three Power Supplies	With Four Power Supplies	With Five Power Supplies
QFX10000-PWR-AC	8100 W	10,800 W	13,500 W
JNP10K-PWR-AC2 dual feed, high power (30-A) setting	16,500 W	22,000 W	27,500 W
JNP10K-PWR-AC2 single feed, high power (20-A) setting	15,000 W	20,000 W	25,000 W
QFX10000-PWR-DC	6,600 W	8,800 W	12,500 W
JNP10K-PWR-DC2 dual feed, high power (80-A) setting	16,500 W	22,000 W	27,500 W
JNP10K-PWR-DC2 dual feed, low power (60-A) setting	13,200 W	17,600 W	22,000 W

**Table 67: Total Power Available (Continued)**

Power Supply Module Models	With Three Power Supplies	With Four Power Supplies	With Five Power Supplies
JNP10K-PWR-DC2 single feed, high power (80-A) setting	8,250 W	11,000 W	13,750 W
JNP10K-PWR-DC2 single feed, low power (60-A) setting	6,600 W	8,800 W	11,000 W

**NOTE:** The HVAC/HVDC power supply, JNP10K-PWR-AC2, has a set of DIP switches on the faceplate that allows you to configure the power supply for either high power (30 A) or low power (20 A) input mode. If any JNP10K-PWR-AC2 power supply is set to 20 A, then the power budget for all power supplies installed in the system becomes 20 A, regardless if other power supplies are set at 30 A. This design is to prevent overloading of the power supply that is set to 20 A. See [Table 14 on page 50](#) for details on setting the DIP switches.

- Determine the total power required for your configuration with line cards installed. The total power available to the chassis is calculated by dividing the wattage needed by the power rating, then rounding up.

In the previous examples, we calculated that a QFX10008 AC system would require 9385 W with five QFX10000-36Q and three QFX10000-30C line cards. In this example, we calculate the total power available for this configuration:

$$= (9375 \text{ W}) / (2700 \text{ W})$$

$$= 3.47$$

Round up the result to 4 AC power supplies, which is the minimum number without a redundant power supply (RPS). Add one more power supply for a  $n+1$  redundancy. In this example, a total of five power supplies are needed.

## QFX10008 and QFX100016 Grounding Cable and Lug Specifications

You must install the switch in a restricted-access location and ensure it is adequately grounded at all times. Proper grounding ensures your switch is operating correctly and that it meets safety and electromagnetic interference (EMI) requirements. A QFX modular chassis, has a 2-hole protective grounding terminal on the rear of the chassis beneath the power supplies for grounding.

For AC powered systems, you must also use the grounding wire in the AC power cord along with the 2-hole lug ground connection. This tested system meets or exceeds all applicable EMC regulatory requirements with the 2-hole protective grounding terminal.



**WARNING:** To comply with GR-1089 requirements, all intra-building copper cabling used for SFP+, QSFP+, and QSFP28 ports must be shielded and grounded at both ends.



**CAUTION:** Before switch installation begins, a licensed electrician must attach a cable lug to the grounding cable that you supply. See ["Connect the QFX10008 or QFX10016 to Earth Ground" on page 213](#). A cable with an incorrectly attached lug can damage the switch.

Before connecting the switch to earth ground, review the following information:

- Two threaded inserts (PEM nuts) are provided on the lower rear of the chassis for connecting the switch to earth ground. The grounding points are spaced at 0.63 in. (16 mm) centers.
- The grounding lug required is a Panduit LCD6-10A-L or equivalent (provided). The grounding lug accommodates 6 AWG (13.3 mm<sup>2</sup>) stranded wire. If one or more JNP10K-PWR-DC2 power supplies are installed in the chassis and set for high input (80-A), use the Panduit LCD4-14A-L or equivalent (provided). This lug accommodates 4 AWG (21.1mm<sup>2</sup>) stranded wire.
- The grounding cable that you provide for a QFX10016 must be the same size or heavier than the input wire of each power supply. Minimum recommendations are 6 AWG (13.3 mm<sup>2</sup>) stranded copper wire, Class B; 90° C wire, or as permitted by local code.

### SEE ALSO

[Connecting the QFX10008 or QFX10016 to Power | 213](#)

### RELATED DOCUMENTATION

[QFX10000 AC Power System | 44](#)

# QFX10000 Transceiver and Cable Specifications

## IN THIS SECTION

- QFX10000 Optical Transceiver and Cable Support | 171
- Cable Specifications for QSFP+, QSFP28, and QSFP-DD Transceivers | 172
- Understanding QFX Series Fiber-Optic Cable Signal Loss, Attenuation, and Dispersion | 174
- Calculating Power Budget and Power Margin for Fiber-Optic Cables | 176

## QFX10000 Optical Transceiver and Cable Support

The QFX10000 line cards support optical transceivers, direct attach copper (DAC) cables, and DAC breakout (DACBO) cables for uplinks, downlinks, or as access ports. The QFX10000 Control Board also supports using small form-factor pluggable (SFP) transceivers to connect the SFP management (**MGMT**) port.

You can find information about the optical transceivers supported on your Juniper device by using the Hardware Compatibility Tool. In addition to transceiver and connection type, the optical and cable characteristics—where applicable—are documented for each transceiver. The Hardware Compatibility Tool enables you to search by product, displaying all the transceivers supported on that device, or category, by interface speed or type. The list of supported transceivers for the QFX10008 line cards is located at <https://pathfinder.juniper.net/hct/product/#prd=QFX10008> and for the QFX10016 line cards at <https://pathfinder.juniper.net/hct/product/#prd=QFX10016>.



**CAUTION:** The Juniper Networks Technical Assistance Center (JTAC) provides complete support for Juniper-supplied optical modules and cables. However, JTAC does not provide support for third-party optical modules and cables that are not qualified or supplied by Juniper Networks. If you face a problem running a Juniper device that uses third-party optical modules or cables, JTAC may help you diagnose host-related issues if the observed issue is not, in the opinion of JTAC, related to the use of the third-party optical modules or cables. Your JTAC engineer will likely request that you check the

third-party optical module or cable and, if required, replace it with an equivalent Juniper-qualified component.

Use of third-party optical modules with high-power consumption (for example, coherent ZR or ZR+) can potentially cause thermal damage to or reduce the lifespan of the host equipment. Any damage to the host equipment due to the use of third-party optical modules or cables is the users' responsibility. Juniper Networks will accept no liability for any damage caused due to such use.

## Cable Specifications for QSFP+, QSFP28, and QSFP-DD Transceivers

The 40-Gigabit Ethernet QSFP+, 100-Gigabit Ethernet QSFP28, and 400G (QDD-400G-DR4 and QDD-400G-SR4P2) transceivers that are used in QFX Series switches use 12-ribbon multimode fiber crossover cables with socket MPO-12 (UPC/APC) connectors. The fiber can be either OM3 or OM4. These cables are not sold by Juniper Networks.



**CAUTION:** To maintain agency approvals, use only a properly constructed, shielded cable.

**TIP:** Ensure that you order cables with the correct polarity. Vendors refer to these crossover cables as *key up to key up*, *latch up to latch up*, *Type B*, or *Method B*. If you are using patch panels between two QSFP+ or QSFP28 transceivers, ensure that the proper polarity is maintained through the cable plant.

[Table 68 on page 172](#) describes the signals on each fiber. [Table 69 on page 173](#) shows the pin-to-pin connections for proper polarity.

**Table 68: QSFP+ and QSFP28 Optical Module Receptacle Pinouts**

Fiber	Signal
1	Tx0 (Transmit)
2	Tx1 (Transmit)
3	Tx2 (Transmit)

Table 68: QSFP+ and QSFP28 Optical Module Receptacle Pinouts (*Continued*)

Fiber	Signal
4	Tx3 (Transmit)
5	Unused
6	Unused
7	Unused
8	Unused
9	Rx3 (Receive)
10	Rx2 (Receive)
11	Rx1 (Receive)
12	Rx0 (Receive)

Table 69: QSFP+ MPO Fiber-Optic Crossover Cable Pinouts

Pin	Pin
1	12
2	11
3	10
4	9
5	8



Table 69: QSFP+ MPO Fiber-Optic Crossover Cable Pinouts (*Continued*)

Pin	Pin
6	7
7	6
8	5
9	4
10	3
11	2
12	1

## Understanding QFX Series Fiber-Optic Cable Signal Loss, Attenuation, and Dispersion

### IN THIS SECTION

- [Signal Loss in Multimode and Single-Mode Fiber-Optic Cables | 175](#)
- [Attenuation and Dispersion in Fiber-Optic Cable | 175](#)

To determine the power budget and power margin needed for fiber-optic connections, you need to understand how signal loss, attenuation, and dispersion affect transmission. The QFX Series uses various types of network cables, including multimode and single-mode fiber-optic cables.

## Signal Loss in Multimode and Single-Mode Fiber-Optic Cables

Multimode fiber is large enough in diameter to allow rays of light to reflect internally (bounce off the walls of the fiber). Interfaces with multimode optics typically use LEDs as light sources. However, LEDs are not coherent light sources. They spray varying wavelengths of light into the multimode fiber, which reflect the light at different angles. Light rays travel in jagged lines through a multimode fiber, causing signal dispersion. When light traveling in the fiber core radiates into the fiber cladding (layers of lower refractive index material in close contact with a core material of higher refractive index), higher-order mode loss occurs. Together, these factors reduce the transmission distance of multimode fiber compared to that of single-mode fiber.

Single-mode fiber is so small in diameter that rays of light reflect internally through one layer only. Interfaces with single-mode optics use lasers as light sources. Lasers generate a single wavelength of light, which travels in a straight line through the single-mode fiber. Compared to multimode fiber, single-mode fiber has a higher bandwidth and can carry signals for longer distances. It is consequently more expensive.

For information about the maximum transmission distance and supported wavelength range for the types of single-mode and multimode fiber-optic cables that are connected to the QFX Series, see [the Hardware Compatibility Tool](#). Exceeding the maximum transmission distances can result in significant signal loss, which causes unreliable transmission.

## Attenuation and Dispersion in Fiber-Optic Cable

An optical data link functions correctly provided that modulated light reaching the receiver has enough power to be demodulated correctly. *Attenuation* is the reduction in strength of the light signal during transmission. Passive media components such as cables, cable splices, and connectors cause attenuation. Although attenuation is significantly lower for optical fiber than for other media, it still occurs in both multimode and single-mode transmission. An efficient optical data link must transmit enough light to overcome attenuation.

*Dispersion* is the spreading of the signal over time. The following two types of dispersion can affect signal transmission through an optical data link:

- Chromatic dispersion, which is the spreading of the signal over time caused by the different speeds of light rays.
- Modal dispersion, which is the spreading of the signal over time caused by the different propagation modes in the fiber.

For multimode transmission, modal dispersion, rather than chromatic dispersion or attenuation, usually limits the maximum bit rate and link length. For single-mode transmission, modal dispersion is not a factor. However, at higher bit rates and over longer distances, chromatic dispersion limits the maximum link length.

An efficient optical data link must have enough light to exceed the minimum power that the receiver requires to operate within its specifications. In addition, the total dispersion must be within the limits specified for the type of link in the Telcordia Technologies document GR-253-CORE (Section 4.3) and International Telecommunications Union (ITU) document G.957.

When chromatic dispersion is at the maximum allowed, its effect can be considered as a power penalty in the power budget. The optical power budget must allow for the sum of component attenuation, power penalties (including those from dispersion), and a safety margin for unexpected losses.

## Calculating Power Budget and Power Margin for Fiber-Optic Cables

### IN THIS SECTION

- [How to Calculate Power Budget for Fiber-Optic Cables | 176](#)
- [How to Calculate Power Margin for Fiber-Optic Cables | 177](#)

Use the information in this topic and the specifications for your optical interface to calculate the power budget and power margin for fiber-optic cables.

**TIP:** You can use the [Hardware Compatibility Tool](#) to find information about the pluggable transceivers supported on your Juniper Networks device.

To calculate the power budget and power margin, perform the following tasks:

### How to Calculate Power Budget for Fiber-Optic Cables

To ensure that fiber-optic connections have sufficient power for correct operation, you need to calculate the link's power budget, which is the maximum amount of power it can transmit. When you calculate the power budget, you use a worst-case analysis to provide a margin of error, even though all the parts of an actual system do not operate at the worst-case levels. To calculate the worst-case estimate of power budget ( $P_B$ ), you assume minimum transmitter power ( $P_T$ ) and minimum receiver sensitivity ( $P_R$ ):

$$P_B = P_T - P_R$$

The following hypothetical power budget equation uses values measured in decibels (dB) and decibels referred to one milliwatt (dBm):

$$P_B = P_T - P_R$$

$$P_B = -15 \text{ dBm} - (-28 \text{ dBm})$$

$$P_B = 13 \text{ dB}$$

## How to Calculate Power Margin for Fiber-Optic Cables

After calculating a link's power budget, you can calculate the power margin ( $P_M$ ), which represents the amount of power available after subtracting attenuation or link loss (LL) from the power budget ( $P_B$ ). A worst-case estimate of  $P_M$  assumes maximum LL:

$$P_M = P_B - LL$$

$P_M$  greater than zero indicates that the power budget is sufficient to operate the receiver.

Factors that can cause link loss include higher-order mode losses, modal and chromatic dispersion, connectors, splices, and fiber attenuation. [Table 70 on page 177](#) lists an estimated amount of loss for the factors used in the following sample calculations. For information about the actual amount of signal loss caused by equipment and other factors, refer to vendor documentation.

**Table 70: Estimated Values for Factors Causing Link Loss**

Link-Loss Factor	Estimated Link-Loss Value
Higher-order mode losses	Single mode—None Multimode—0.5 dB
Modal and chromatic dispersion	Single mode—None Multimode—None, if product of bandwidth and distance is less than 500 MHz-km
Faulty connector	0.5 dB
Splice	0.5 dB
Fiber attenuation	Single mode—0.5 dB/km Multimode—1 dB/km

The following sample calculation for a 2-km-long multimode link with a power budget ( $P_B$ ) of 13 dB uses the estimated values from [Table 70 on page 177](#). This example calculates link loss (LL) as the sum of fiber attenuation (2 km @ 1 dB/km, or 2 dB) and loss for five connectors (0.5 dB per connector, or 2.5 dB) and two splices (0.5 dB per splice, or 1 dB) as well as higher-order mode losses (0.5 dB). The power margin ( $P_M$ ) is calculated as follows:

$$P_M = P_B - LL$$

$$P_M = 13 \text{ dB} - 2 \text{ km (1 dB/km)} - 5 (0.5 \text{ dB}) - 2 (0.5 \text{ dB}) - 0.5 \text{ dB}$$

$$P_M = 13 \text{ dB} - 2 \text{ dB} - 2.5 \text{ dB} - 1 \text{ dB} - 0.5 \text{ dB}$$

$$P_M = 7 \text{ dB}$$

The following sample calculation for an 8-km-long single-mode link with a power budget ( $P_B$ ) of 13 dB uses the estimated values from [Table 70 on page 177](#). This example calculates link loss (LL) as the sum of fiber attenuation (8 km @ 0.5 dB/km, or 4 dB) and loss for seven connectors (0.5 dB per connector, or 3.5 dB). The power margin ( $P_M$ ) is calculated as follows:

$$P_M = P_B - LL$$

$$P_M = 13 \text{ dB} - 8 \text{ km (0.5 dB/km)} - 7(0.5 \text{ dB})$$

$$P_M = 13 \text{ dB} - 4 \text{ dB} - 3.5 \text{ dB}$$

$$P_M = 5.5 \text{ dB}$$

In both examples, the calculated power margin is greater than zero, indicating that the link has sufficient power for transmission and does not exceed the maximum receiver input power.

## RELATED DOCUMENTATION

[QFX10000 Line Cards | 88](#)

[Maintaining QFX10000 Line Cards | 309](#)

# QFX10000 Console and Management Cable Specifications and Pinouts

## IN THIS SECTION

- [QFX10000 Cable Specifications for Console and Management Connections | 179](#)
- [RJ-45 to DB-9 Serial Port Adapter Pinout Information | 180](#)
- [RJ-45 Management Port Connector Pinout Information | 181](#)
- [Console Port Connector Pinout Information | 182](#)
- [USB Port Specifications for the QFX Series | 183](#)

## QFX10000 Cable Specifications for Console and Management Connections

[Table 71 on page 179](#) lists the specifications for the cables that connect the QFX10000 line of switches to a management device.

**NOTE:** The QFX10000 models can be configured with SFP management ports that support 1000BASE-SX transceivers. See [The Hardware Compatibility Tool](#) for more on the fiber-optic cables required for use with these transceivers.

**Table 71: Cable Specifications for Console and Management Connections for the QFX10000 Line of Switches**

Port on QFX Series Device	Cable Specification	Cable Supplied	Maximum Length	Device Receptacle
Console port	RS-232 (EIA-232) serial cable	One 7-foot (2.13-meter) long RJ-45 patch cable and RJ-45 to DB-9 adapter	7 feet (2.13 meters)	RJ-45

**Table 71: Cable Specifications for Console and Management Connections for the QFX10000 Line of Switches (Continued)**

Port on QFX Series Device	Cable Specification	Cable Supplied	Maximum Length	Device Receptacle
Management port	Category 5 cable or equivalent suitable for 1000BASE-T operation	One 7-foot (2.13-meter) long RJ-45 patch cable	328 feet (100 meters)	RJ-45

## SEE ALSO

*Console Port Connector Pinouts for the QFX Series*

*Management Port Connector Pinouts for the QFX Series*

*Connecting a QFX Series Device to a Management Console*

## RJ-45 to DB-9 Serial Port Adapter Pinout Information

The console port on a Juniper Networks device is an RS-232 serial interface that uses an RJ-45 connector to connect to a management device such as a laptop or a desktop PC. If your laptop or desktop PC does not have a DB-9 plug connector pin and you want to connect your laptop or desktop PC to the device, use a combination of the RJ-45 to DB-9 socket adapter along with a USB to DB-9 plug adapter.

[Table 72 on page 180](#) provides the pinout information for the RJ-45 to DB-9 serial port adapter.

**Table 72: RJ-45 to DB-9 Serial Port Adapter Pinout Information**

RJ-45 pin	Signal	DB-9 pin	Signal
1	NC	8	CTS
2	NC	6	DSR
3	TxD	2	RxD

**Table 72: RJ-45 to DB-9 Serial Port Adapter Pinout Information (Continued)**

RJ-45 pin	Signal	DB-9 pin	Signal
4	GND	5	GND
6	RxD	3	TxD
7	DCD	4	DTR
8	NC	7	RTS

## RJ-45 Management Port Connector Pinout Information

[Table 73 on page 181](#) provides the pinout information for the RJ-45 connector for the management port on Juniper Networks devices.

**Table 73: RJ-45 Management Port Connector Pinout Information**

Pin	Signal	Description
1	TRP1+	Transmit/receive data pair 1
2	TRP1-	Transmit/receive data pair 1
3	TRP2+	Transmit/receive data pair 2
4	TRP3+	Transmit/receive data pair 3
5	TRP3-	Transmit/receive data pair 3
6	TRP2-	Transmit/receive data pair 2



Table 73: RJ-45 Management Port Connector Pinout Information (*Continued*)

Pin	Signal	Description
7	TRP4+	Transmit/receive data pair 4
8	TRP4-	Transmit/receive data pair 4

## Console Port Connector Pinout Information

The console port on a Juniper Networks device is an RS-232 serial interface that uses an RJ-45 connector to connect to a console management device. The default baud rate for the console port is 9600 baud.

Table 74 on page 183 provides the pinout information for the RJ-45 console connector.

**NOTE:** We no longer include the RJ-45 console cable with the DB-9 adapter as part of the device package. If the console cable and adapter are not included in your device package, or if you need a different type of adapter, you can order the following separately:

- RJ-45 to DB-9 adapter (JNP-CBL-RJ45-DB9)
- RJ-45 to USB-A adapter (JNP-CBL-RJ45-USBA)
- RJ-45 to USB-C adapter (JNP-CBL-RJ45-USBC)

If you want to use RJ-45 to USB-A or RJ-45 to USB-C adapter you must have X64 (64-Bit) Virtual COM port (VCP) driver installed on your PC. See, <https://ftdichip.com/drivers/vcp-drivers/> to download the driver.

**NOTE:** If your laptop or desktop PC does not have a DB-9 plug connector pin and you want to connect your laptop or desktop PC directly to a device, use a combination of the RJ-45-to-DB-9 socket adapter and a USB-to-DB-9 plug adapter. You must provide the USB-to-DB-9 plug adapter.

**Table 74: Console Port Connector Pinout Information**

Pin	Signal	Description
1	NC	No connect
2	NC	No connect
3	TxD Output	Transmit data
4	GND	Signal ground
5	GND	Signal ground
6	RxD Input	Receive data
7	DCD Input	Data carrier detect
8	NC	No connect

## USB Port Specifications for the QFX Series

The following Juniper Networks USB flash drives have been tested and are officially supported for the USB port in the QFX Series:

- RE-USB-1G-S—1-gigabyte (GB) USB flash drive (except QFX3100 Director device)
- RE-USB-2G-S—2-GB USB flash drive (except QFX3100 Director device)
- RE-USB-4G-S—4-GB USB flash drive



**CAUTION:** Any USB memory product not listed as supported for the QFX Series has not been tested by Juniper Networks. The use of any unsupported USB memory product could expose your device to unpredictable behavior. Juniper Networks Technical Assistance Center (JTAC) can provide only limited support for issues related to

unsupported hardware. We strongly recommend that you use only supported USB flash drives.



**CAUTION:** Remove the USB flash drive before upgrading Junos OS or rebooting a QFX Series device. Failure to do so could expose your device to unpredictable behavior.

**NOTE:** Executing the `request system snapshot` CLI command on a QFX3500 device requires an external USB flash drive with at least 4 GB of free space. We recommend using the RE-USB-4G-S flash drive.

**NOTE:** USB flash drives used with the QFX Series device must support USB 2.0 or later.

## RELATED DOCUMENTATION

| [Connecting the QFX10000 to External Devices](#) | 218

# 3

CHAPTER

## Initial Installation and Configuration

---

[QFX10008 Installation Overview | 186](#)

[Unpacking the QFX10008 | 187](#)

[Installing the Mounting Hardware for a QFX10000 | 197](#)

[Installing the QFX10008 into a Rack | 200](#)

[Installing the Front Panel on a QFX10000 | 207](#)

[Connecting the QFX10008 or QFX10016 to Power | 213](#)

[Connecting the QFX10000 to External Devices | 218](#)

[Performing an Initial Configuration of a QFX10000 | 221](#)

---

# QFX10008 Installation Overview

The QFX10008 is a rigid sheet-metal switch-chassis that houses the other hardware components such as control boards, Switch Interface Boards (SIBs), power supplies, fan trays, and line cards. The switch chassis ships in a cardboard box that has a two-layer wooden pallet base. The switch chassis is bolted to the pallet base. You can install a QFX10008 switch in a standard 19 in. (483 mm) equipment rack by using the supplied rack-mounting kit and the front-mounting bracket that is attached to the chassis.

The steps to install the QFX10008 are:

1. Unpack the switch following the instructions in ["Unpacking the QFX10008" on page 187](#).
2. Mount the chassis in the rack following either the instructions in ["Mounting a QFX10008 in a 4-Post Rack Using a Mechanical Lift" on page 200](#) or in ["Manually Mounting a QFX10008 in a 4-Post Rack" on page 203](#).

Because of the weight of the chassis, mounting using a mechanical lift is preferred as the easiest and safest method.

3. Install the line cards following the instructions in ["Installing a QFX10000 Line Card" on page 313](#).
4. Connect the chassis to earth ground following the instructions in ["Connect the QFX10008 or QFX10016 to Earth Ground" on page 213](#).
5. Connect power to the power supplies following either the instructions in ["Connect AC Power to a QFX Modular Chassis" on page 217](#) or ["Connect DC Power to a QFX10008 or QFX10016" on page 217](#).
6. Connect to the network.
  - To connect the switch to a network for out-of-band management, follow instructions in ["Connect a Device to a Network for Out-of-Band Management" on page 219](#).
  - To connect the switch to a management console, follow instructions in ["Connect a Device to a Management Console Using an RJ-45 Connector" on page 219](#).
7. Configure the switch following the instructions in ["Performing an Initial Configuration of a QFX10000" on page 221](#).
8. Install optional equipment such as the SATA SSD or the cable management system. See ["Installing the Optional SATA Solid State Drive in a QFX10000" on page 321](#) and ["Installing the QFX10000 Cable Management System" on page 316](#).

## RELATED DOCUMENTATION

[QFX10000 Rack Requirements | 155](#)

[QFX10000 Clearance Requirements for Airflow and Hardware Maintenance | 158](#)

[QFX10002 Installation Safety Guidelines](#)

# Unpacking the QFX10008

## IN THIS SECTION

- [Unpacking the Chassis | 187](#)
- [Unpacking QFX10000 Line Cards, Routing and Control Boards, and Switch Interface Boards | 189](#)
- [Comparing the QFX10000 Order to the Packing List | 191](#)
- [Register Products—Mandatory to Validate SLAs | 197](#)

## Unpacking the Chassis

After you prepare the installation site as described in "[QFX10008 Site Preparation Checklist](#)" on page 150, you can unpack the switch.

**NOTE:** The chassis is maximally protected inside the shipping box. Do not unpack it until you are ready to begin installation.

Ensure that you have the following parts and tools available to unpack the QFX10008:

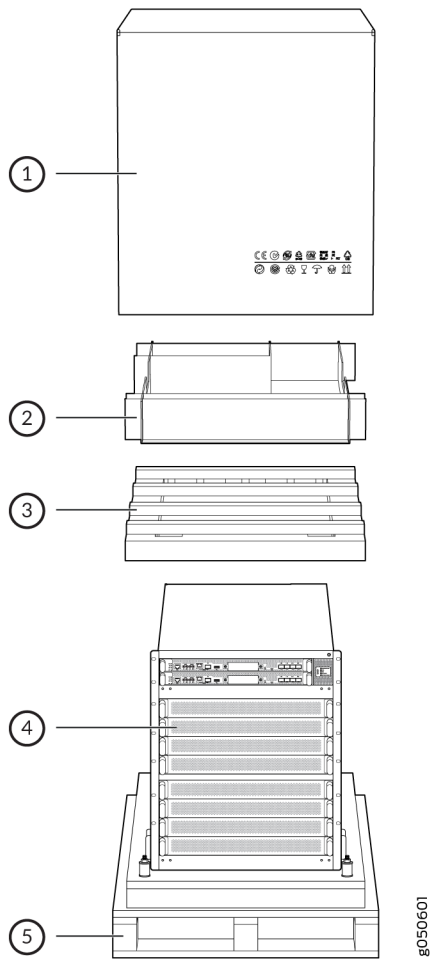
- A 13/32 in. (10 mm) open-end or socket wrench to remove the bracket bolts from the shipping pallet
- A box cutter or packing knife to slice open the nylon straps and tape that seal the crate and boxes

The chassis ships in a cardboard box that has a two-layer wooden pallet base with foam cushioning between the layers. The switch chassis is bolted to the pallet base.

The shipper has the option to either ship the front panel separately or to ship along with the chassis. If the front panel arrives with the chassis, set aside the front panel box until you are ready to verify the contents of the order.

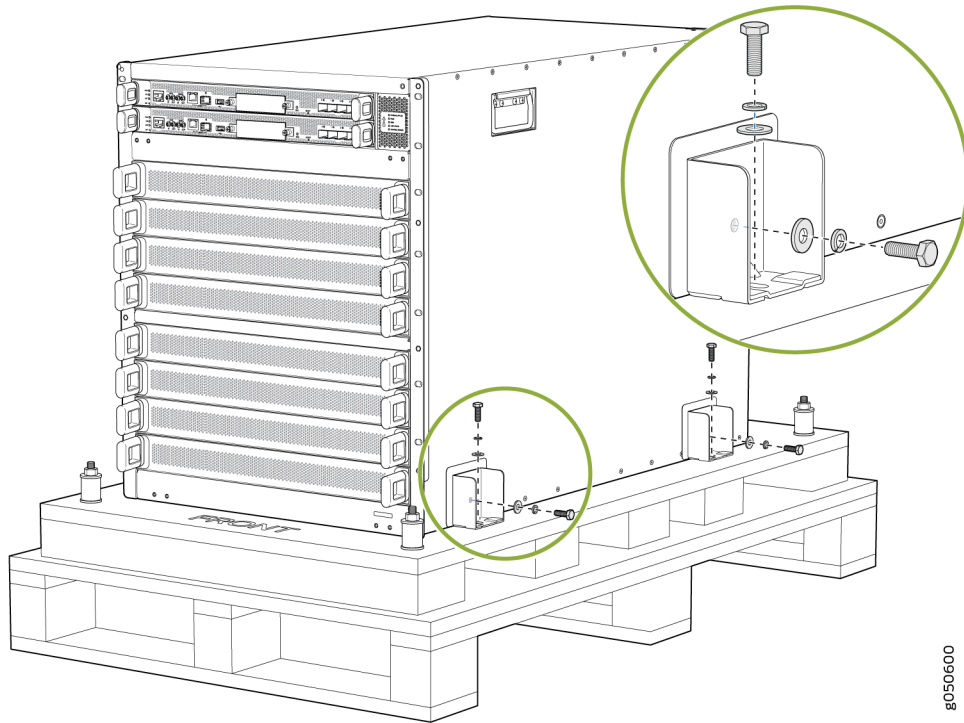
To unpack the chassis (see [Figure 71 on page 188](#)):

**Figure 71: Shipping Crate and Accessory Box**



1. Move the shipping box to a staging area as close to the installation site as possible. While the chassis is bolted to the pallet, you can use a forklift or pallet jack to move it. Make sure there is enough space to remove components from the chassis.
2. Position the shipping box with the arrows pointing up.
3. Slice the nylon straps with the box cutter that hold the shipping boxes to the pallet.
4. Lift the shipping box off the chassis.
5. Remove the cardboard accessory box.
6. Remove the foam padding from the top of the box.
7. Remove the plastic cover from the switch chassis.
8. Use a 13/32 in. (10 mm) open-end or socket wrench to remove the four sets of bracket bolts that secure the chassis to the shipping pallet (see [Figure 72 on page 189](#)).

Figure 72: Bracket Bolt Removal



9. Unpack the accessory box and lay out the contents so that they are ready for use.
10. Verify that your order includes all appropriate parts. See ["Comparing the QFX10000 Order to the Packing List"](#) on page 191 and ["QFX10008 Configurations and Upgrade Options"](#) on page 14 for information about base configurations and redundant configurations.
11. Store the brackets and bolts inside the accessory box.
12. Save the shipping box and packing materials in case you need to move or ship the switch at a later time.

#### SEE ALSO

[Installing the QFX10008 into a Rack](#) | 200

## Unpacking QFX10000 Line Cards, Routing and Control Boards, and Switch Interface Boards

Before you unpack a component:



- Ensure that you have taken the necessary precautions to prevent electrostatic discharge (ESD) damage. See [Prevention of Electrostatic Discharge Damage](#).
- Ensure that you know how to handle and store the component. (See "[Handling and Storing QFX10000 Line Cards, RCBs, and SIBs](#)" on page 226).

Orders for line cards, additional Routing and Control Boards (RCBs), and Switch Interface Boards (SIBs) components are FRUs that are shipped separately from the switch chassis. The housing for the RCBs and line cards are rigid sheet-metal structures that house the electronics. SIBs have an exposed printed circuit board on one side and sheet metal on the other. All these components are shipped in a cardboard carton, secured with packing material.

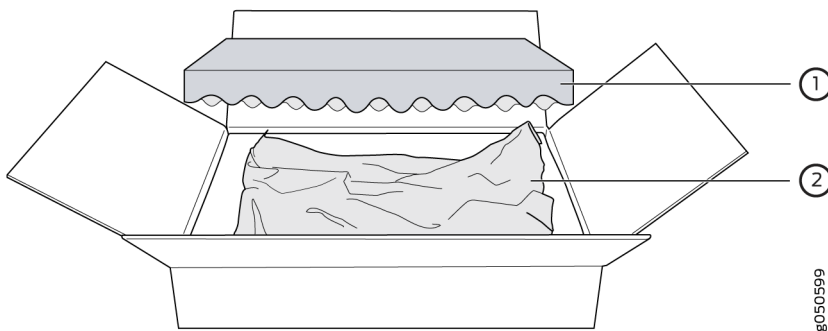


**CAUTION:** The components are maximally protected inside the shipping carton. Do not unpack them until you are ready to install the components in the switch chassis.

To unpack an RCB, SIB, or line card, (see [Figure 73 on page 190](#)):

1. Move the shipping carton to a staging area as close to the installation site as possible.
2. Position the carton so that the arrows are pointing up.
3. Open the top flaps on the shipping carton.
4. Pull out the packing material that holds the component in place.
5. Remove the component from the electrostatic bag.
6. Save the shipping carton and packing materials for later, in case you need to move or ship the RCB, SIB, or line card.

**Figure 73: Unpacking a Line Card**



6650509

1– Foam packing material

2– Paper packaging and electrostatic bag

## SEE ALSO

[Installing a QFX10000 Line Card | 313](#)

[Installing a QFX10000 Switch Interface Board | 303](#)

[Installing a QFX10000 Routing and Control Board | 232](#)

## Comparing the QFX10000 Order to the Packing List

Use the following procedure to compare the sales order and packing list against the contents of the chassis shipping crate.

The switch chassis shipment includes a packing list. Check the parts you receive in the shipping crate against the items on the packing list. The packing list specifies the part number and description of each part in your order.

If any part on the packing list is missing, contact your customer service representative, or contact Juniper Networks Customer Care from within the U.S. or Canada by telephone at 1-888-314-5822. For international-dial or direct-dial options in countries without toll-free numbers, see <https://www.juniper.net/support/requesting-support.html>.

Items that ship separately from the chassis are:

- Line cards
- Chassis front panel kit

**NOTE:** The kit is a spare part and can ship with the chassis or separately.

- Cable management kit
- SATA solid state drive

1. Determine the configuration. The parts shipped depend on the configuration you order. Supported configurations are:

- Redundant configuration. See [Table 75 on page 192](#).
  - QFX10008-REDUND
  - QFX10008-REDUND-DC
  - QFX10008-REDUND-H
  - QFX10016-REDUND

- QFX10016-REDUND-DC
- Base configuration. See [Table 76 on page 193](#).
- QFX10008-BASE
- QFX10008-BASE-H
- QFX10016-BASE

2. Compare redundant configuration orders using [Table 75 on page 192](#).

**Table 75: Redundant Configuration Order**

Component	QFX10008 Quantity	QFX10016 Quantity
Chassis, including power bus	1	1
Routing Control Boards	2	2
Fan tray controllers	2	2
Fan trays	2	2
Power supplies <ul style="list-style-type: none"> <li>• QFX10000-PWR-AC</li> <li>• JNP10K-PWR-AC2</li> <li>• QFX10000-PWR-DC</li> <li>• JNP10K-PWR-DC2</li> </ul>	6	10
DC terminal lugs, 2-hole, 10-32, 4 AWG	24 for DC systems only	40 for DC systems only
Power cables	12 for AC systems; 0 for DC systems	20 for AC systems; 0 for DC systems
Switch Interface Boards (SIBs)	6	6

**Table 75: Redundant Configuration Order (Continued)**

Component	QFX10008 Quantity	QFX10016 Quantity
Line card slot covers	8	16
Accessory kit (see <a href="#">Table 77 on page 195</a> )	1	1
Rack mount kit (see <a href="#">Table 78 on page 196</a> )	1	1
Front panel kit (see <a href="#">Table 79 on page 196</a> )	1	1
Documentation roadmap	1	1
Port dust covers	10	10

3. Compare base configuration orders using [Table 76 on page 193](#).

**Table 76: Base Configuration Order**

Component	QFX10008 Quantity	QFX10016 Quantity
Chassis, including power bus	1	1
Routing Control Boards	1	1
Routing Control Board slot cover	1	1
Fan tray controllers	2	2
Fan trays	2	2

Table 76: Base Configuration Order (Continued)

Component	QFX10008 Quantity	QFX10016 Quantity
Power supplies <ul style="list-style-type: none"> <li>• QFX10000-PWR-AC</li> <li>• JNP10K-PWR-AC2</li> <li>• QFX10000-PWR-DC</li> <li>• JNP10K-PWR-DC2</li> </ul>	3	5
DC terminal lugs, 2-hole, 10-32, 4 AWG	12, DC power supplies only	20, DC power supplies only
Power cables	6, AC power supplies only	10, AC power supplies only
SIBs	5	5
SIB slot cover	1	1
Power supply slot cover	3	5
Line card slot cover	8	16
Accessory kit (see <a href="#">Table 77 on page 195</a> )	1	1
Rack mount kit (see <a href="#">Table 78 on page 196</a> )	1	1
Front panel kit (see <a href="#">Table 79 on page 196</a> )	1	1
Documentation Roadmap	1	1
Port dust covers	5	5

4. Compare the contents of the accessory kit with [Table 77 on page 195](#).

Table 77: QFX10000 Accessory Kit

Component	AC Configurations Quantity	DC Configurations Quantity
Warranty card	1	1
End-user license agreement (EULA)	1	1
Electrostatic discharge (ESD) wrist strap with cable	1	1
Media kit (flash drives, PCMCIA card adapter)	1	1
Chassis ground lug, 2-hole, 10-32, 6 AWG	1	1
Power cord retainer clips		
<ul style="list-style-type: none"> <li>• QFX10008</li> <li>• QFX10016</li> </ul>	<ul style="list-style-type: none"> <li>• Redundant, 12 Base, 6</li> <li>• Redundant, 20 Base, 10</li> </ul>	<ul style="list-style-type: none"> <li>-</li> <li>-</li> </ul>
ESD bags <ul style="list-style-type: none"> <li>• 3 in. x 5 in.</li> <li>• 4 in. x 6 in.</li> <li>• 9 in. x 12 in.</li> </ul>	3	

**NOTE:** We no longer include the RJ-45 console cable with the DB-9 adapter as part of the device package. If the console cable and adapter are not included in your device package, or if you need a different type of adapter, you can order the following separately:

- RJ-45 to DB-9 adapter (JNP-CBL-RJ45-DB9)
- RJ-45 to USB-A adapter (JNP-CBL-RJ45-USBA)
- RJ-45 to USB-C adapter (JNP-CBL-RJ45-USBC)

If you want to use RJ-45 to USB-A or RJ-45 to USB-C adapter you must have X64 (64-Bit) Virtual COM port (VCP) driver installed on your PC. See, <https://ftdichip.com/drivers/vcp-drivers/> to download the driver.

5. Compare the contents of the rack mount kit with [Table 78 on page 196](#).

**Table 78: QFX10000 Rack Mount Kit**

Component	Quantity
Phillips flat-head screws, 8-32 x .375 in.	12
Rear brackets	2
Right base bracket	1
Left base bracket	1

6. Compare the contents of the front panel kit with [Table 79 on page 196](#).

**Table 79: QFX10000 Front Panel Kit**

Component	Quantity
Front panel	1
Left base bracket	1
Right base bracket	1

Table 79: QFX10000 Front Panel Kit (Continued)

Component	Quantity
Latch brackets	2
Phillips flat-head screws	8
Warranty card	1

## Register Products—Mandatory to Validate SLAs

Register all new Juniper Networks hardware products and changes to an existing installed product using the Juniper Networks website to activate your hardware replacement service-level agreements (SLAs).



**CAUTION:** Register product serial numbers on the Juniper Networks website. Update the installation base data if any addition or change to the installation base occurs or if the installation base is moved. Juniper Networks is not responsible for not meeting the hardware replacement service-level agreement for products that do not have registered serial numbers or accurate installation base data.

Register your product(s) at <https://tools.juniper.net/svcreg/SRegSerialNum.jsp>.

Update your installation base at <https://www.juniper.net/customers/csc/management/updateinstallbase.jsp>.

### RELATED DOCUMENTATION

[QFX10008 Configurations and Upgrade Options | 14](#)

## Installing the Mounting Hardware for a QFX10000

Ensure that you have the following parts and tools available to install the mounting hardware:

- A Phillips (+) screwdriver, number 1, 2, or 3, depending on the size of your rack screws



- A Phillips (+) screwdriver, number 2, to install the screws that connect the rear and base brackets
- 12 Phillips flat-head screws (provided)
- 14 mounting screws appropriate for your rack to attach the mounting hardware to the rack (not provided)

The switch can be installed in a four-post rack or in an open-frame rack. Install the mounting hardware on the rack before installing the switch.

To mount the chassis on a four-post rack, you must first install the mounting hardware in the rack. QFX10008 and QFX10016 switches come with a four-piece set of mounting brackets that support the chassis in the rack. This rack mount kit, EX-MOD-RMK-4POST, can be ordered as a spare. However, if you prefer a solid-shelf design for the rack, JNP-MOD-RMK-4PST is also available by separate order.

**NOTE:** Two-post installation racks are not supported.

The main pieces of the rack mount kit are:

- One left base bracket. The bracket is labeled **LEFT FRONT** on the side of the bracket that faces the interior of the rack, near the holes for attaching the bracket to the rack.
- One right base bracket. The bracket is labeled **RIGHT FRONT** on the side of the bracket that faces the interior of the rack, near the holes for attaching the bracket to the rack.
- Two rear brackets. These brackets are labeled **REAR** on the side of the bracket that faces the interior of the rack, near the holes for attaching the bracket to the rack. The rear brackets are interchangeable; you can use either of the rear brackets with the right or left base bracket.

When you install the base and rear brackets, the adjustable portion of the brackets overlap. Use the overlap area to adjust the total bracket length to fit any of the four standard rack sizes: 19 in. (483 mm), 23.62 in. (600 mm), 30 in. (762 mm), or 31.5 in. (800 mm).

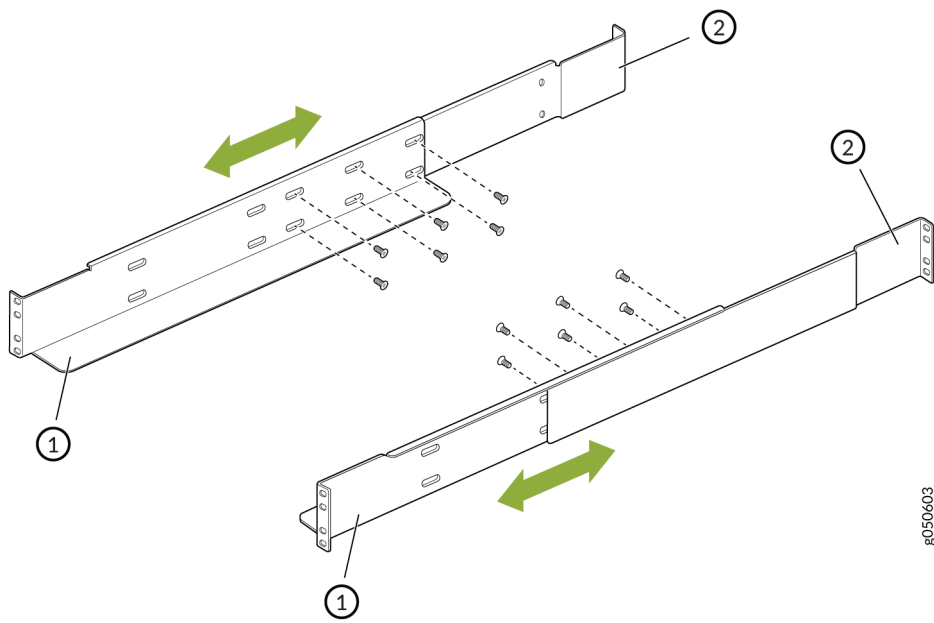
To install the mounting hardware in a four-post rack:

1. Remove the mounting brackets from the rack mount kit box.
2. Decide where to place the chassis in the rack. If the rack is empty, mount the switch in the lowest possible location. See "[QFX10000 Rack Requirements](#)" on page 155.
3. Position the left base bracket at the desired position in the left side of the rack and line up its front screw holes with the holes in the rack. Use four mounting screws appropriate for your rack to attach the left base bracket to the rack.
4. Position one of the rear brackets at the left rear of the rack on the same level as the left base bracket, so that the rear bracket overlaps with the left base bracket. The screw holes for connecting the base

and rear brackets should overlap. Use four mounting screws appropriate for your rack to attach the rear bracket to the rack.

5. Connect left base bracket and rear brackets (see [Figure 74 on page 199](#)):
  - a. Insert six of the flat-head screws provided with the mounting brackets into the overlapping bracket holes.
  - b. Hand-tighten the screws fully (to 12–16 in.-lb torque) using a number 2 Phillips screwdriver.

**Figure 74: Mounting Brackets for Four-Post Rack Installation**



1– Right and left base brackets

2– Rear brackets

6. Position the right base bracket at the desired position in the right side of the rack opposite the installed left base bracket, so that it is on the same rack level as the left base bracket. If the right and left base brackets are not on the same level, the chassis will rest at an angle in the rack instead of resting flat and level. Line up the right base bracket's front screw holes with the holes in the rack. Use four mounting screws appropriate for your rack to attach the right base bracket to front of the rack.
7. Position the other rear bracket at the right rear of the rack on the same level as the right base bracket, so that the rear bracket overlaps with the right base bracket. The screw holes for connecting the base and rear brackets should overlap. Use four mounting screws appropriate for your rack to attach the rear bracket to the rack.
8. Connect the right base and rear brackets (see [Figure 74 on page 199](#)):
  - a. Insert six of the screws provided with the mounting brackets into the overlapping bracket holes.
  - b. Hand-tighten the screws fully (to 12–16 in.-lb torque) using a number 2 Phillips screwdriver.

## RELATED DOCUMENTATION

| [QFX10016 Chassis Lifting Guidelines](#)

# Installing the QFX10008 into a Rack

## IN THIS SECTION

- [Mounting a QFX10008 in a 4-Post Rack Using a Mechanical Lift | 200](#)
- [Manually Mounting a QFX10008 in a 4-Post Rack | 203](#)

You can install a QFX10008 router into a rack by using a mechanical lift, or you can install it manually. The following sections describe both the procedures.

## Mounting a QFX10008 in a 4-Post Rack Using a Mechanical Lift

Before you install the switch:

- Prepare the site for installation as described in "[QFX10008 Site Preparation Checklist](#)" on page 150.
- Ensure the site has adequate clearance for both airflow and hardware maintenance as described in "[QFX10000 Clearance Requirements for Airflow and Hardware Maintenance](#)" on page 158.
- Unpack the switch as described in "[Unpacking the QFX10008](#)" on page 187.
- In a four-post rack, install the mounting hardware at the desired position (see "[Installing the Mounting Hardware for a QFX10000](#)" on page 197).
- Review chassis lifting guidelines described in "[Chassis and Component Lifting Guidelines](#)" on page 375.

Ensure that you have the following parts and tools available to install the switch:

- A mechanical lift rated for 350 lbs. (158.8 kg)
- 14 mounting screws appropriate for your rack
- A Phillips (+) screwdriver, number 2 or number 3, depending on the size of your mounting screws

Because of the switch's size and weight, we strongly recommend using a mechanical lift to install the QFX10008.

**NOTE:** For instructions on installing a switch without using a mechanical lift, see ["Manually Mounting a QFX10008 in a 4-Post Rack" on page 203](#).



**CAUTION:** Do not install line cards in the chassis until after you mount the chassis securely on a rack or cabinet.



**CAUTION:** Before front-mounting the switch on a rack or cabinet, have a qualified technician verify that the rack or cabinet is strong enough to support the switch's weight and is adequately supported at the installation site.



**CAUTION:** If you are installing more than one switch in a rack or cabinet, install the first switch at the bottom of the rack.

To install the switch using a mechanical lift (see [Figure 75 on page 202](#)):

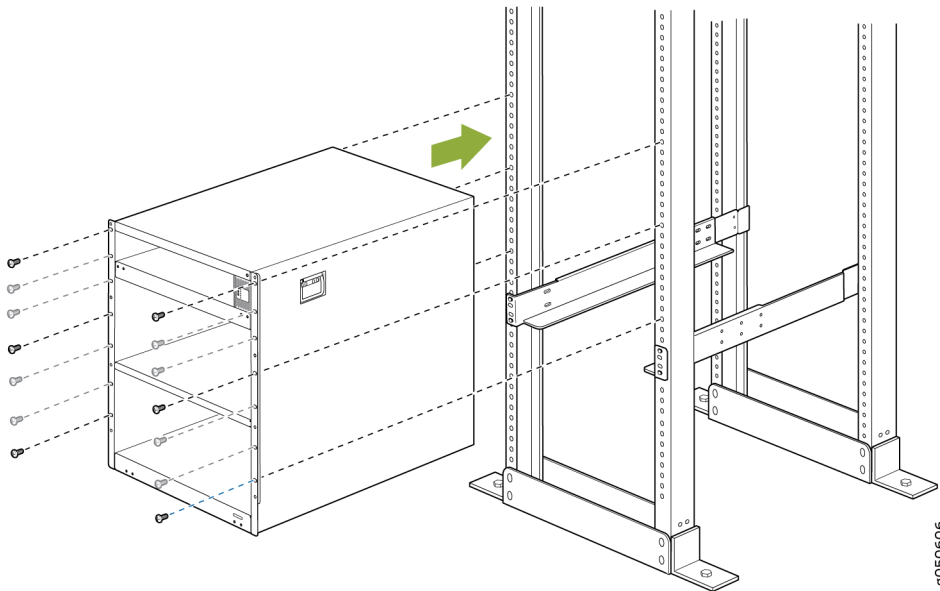
1. Ensure that the rack or cabinet is placed in its permanent location and is secured to the building. Ensure that the installation site allows adequate clearance for both airflow and maintenance. For details, see ["QFX10000 Clearance Requirements for Airflow and Hardware Maintenance" on page 158](#).
2. Load the switch onto the lift, making sure it rests securely on the lift platform.

Figure 75: Loading the QFX10008 into a Rack Using a Mechanical Lift



3. Using the lift, align the switch in front of the rack, centering it in front of the base brackets.
4. Lift the chassis approximately 0.75 in. (1.9 cm) above the surface of the base brackets. Align the chassis as close as possible to the base brackets.
5. Carefully slide the chassis onto the adjustable base and rear mounting brackets until the chassis flanges contact the rack rails. The mounting brackets ensure that the holes in the flanges align with the holes in the rack rails. See [Figure 76 on page 203](#).

Figure 76: Attaching the Chassis Flanges to the Rack



6. Move the lift away from the rack.
7. Attach the chassis to the rack by installing a mounting screw through the open flange holes and rack, starting from the bottom.
8. Visually inspect the alignment of the switch. If the switch is installed properly in the rack, all the mounting screws on one side of the rack are aligned with the mounting screws on the opposite side and the switch is level.
9. After ensuring that the switch is aligned properly, tighten the screws using a screwdriver..
10. After you install the mounting screws and securely bolt the chassis to the rack, reinstall the components in the chassis.

#### SEE ALSO

[Performing an Initial Configuration of a QFX10000 | 221](#)

## Manually Mounting a QFX10008 in a 4-Post Rack

Before you install the switch:

1. Prepare the site for installation as described in "[QFX10008 Site Preparation Checklist](#)" on page 150.

2. Ensure the site has adequate clearance for both airflow and hardware maintenance as described in ["QFX10000 Clearance Requirements for Airflow and Hardware Maintenance"](#) on page 158.
3. Unpack the switch as described in ["Unpacking the Chassis"](#) on page 187.
4. Remove all components except the two fan tray controllers from the chassis. See:
  - ["Removing a QFX10000 Routing and Control Board"](#) on page 230
  - ["Removing a QFX10000 Switch Interface Board"](#) on page 298
  - ["Removing a QFX10008 Fan Tray"](#) on page 235
  - ["How to Remove a QFX10000-PWR-AC Power Supply"](#) on page 244 or ["How to Remove a QFX10000-PWR-DC Power Supply"](#) on page 267
5. Install the mounting hardware at the desired position (see ["Installing the Mounting Hardware for a QFX10000"](#) on page 197).
6. Review chassis lifting guidelines as described in ["Chassis and Component Lifting Guidelines"](#) on page 375.

Ensure that you have the following parts and tools available to install the switch:

- 14 mounting screws appropriate for your rack
- A Phillips (+) screwdriver, number 2 or number 3, depending on the size of your rack screws

If you cannot use a mechanical lift to install the switch (the preferred method), you can install it manually.



**CAUTION:** The chassis weighs approximately 145 lb (66 kg) with only the fan tray controllers installed. Lifting the chassis and mounting it in a rack or cabinet requires at least three people. Make sure the chassis is empty (contains only the backplane) before you lift it.

The chassis has two handles that are designed for subtle positioning of the chassis. Do not lift the chassis by the handles.



**CAUTION:** Before front-mounting the switch in a rack, have a qualified technician verify that the rack is strong enough to support the switch's weight and is adequately supported at the installation site.

To install the switch in the rack or cabinet (see [Figure 78 on page 207](#)):



**CAUTION:** If you are installing more than one switch in a rack or cabinet, install the first one at the bottom of the rack. Do not attempt to install a switch manually in an upper position in a rack or cabinet.

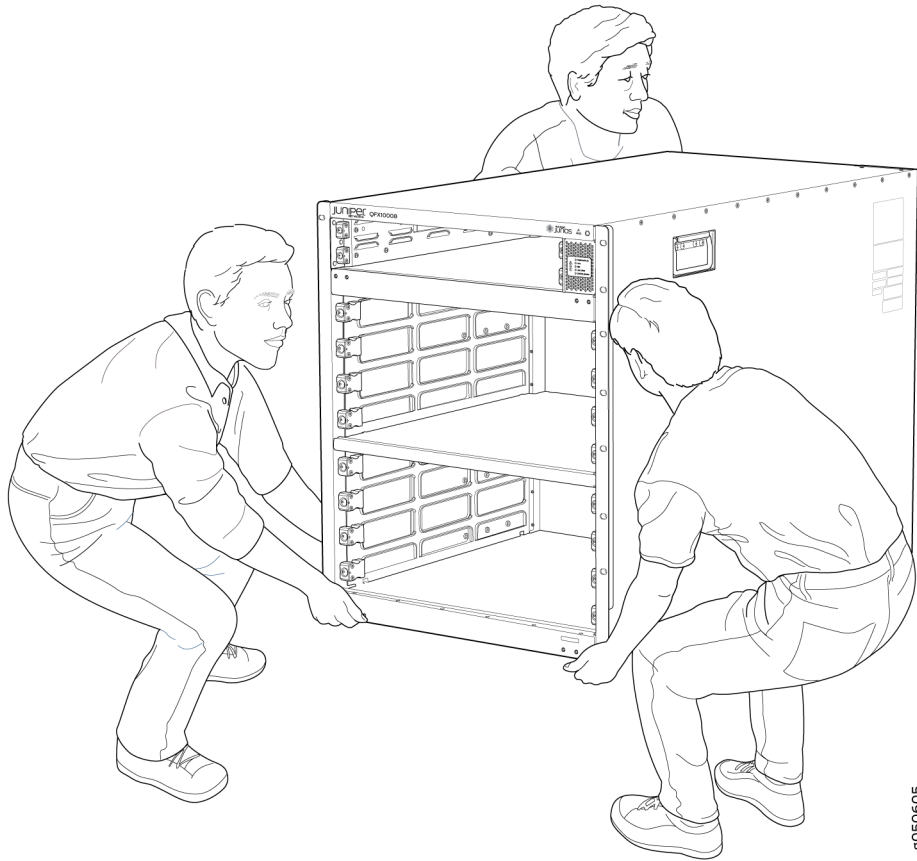
1. Ensure that the rack or cabinet is placed in its permanent location and is secured to the building.
2. Align the switch in front of the rack or cabinet, centering it in front of the adjustable base and rear mounting brackets. Use a pallet jack if one is available.
3. With one person on each side and one person in the rear, hold the bottom of the chassis and carefully lift it onto the adjustable base and rear brackets installed in a four-post rack. See [Figure 77 on page 206](#).



**WARNING:** To prevent injury, keep your back straight and lift with your legs, not your back. Do not twist your body as you lift. Balance the load evenly and be sure that your footing is firm.

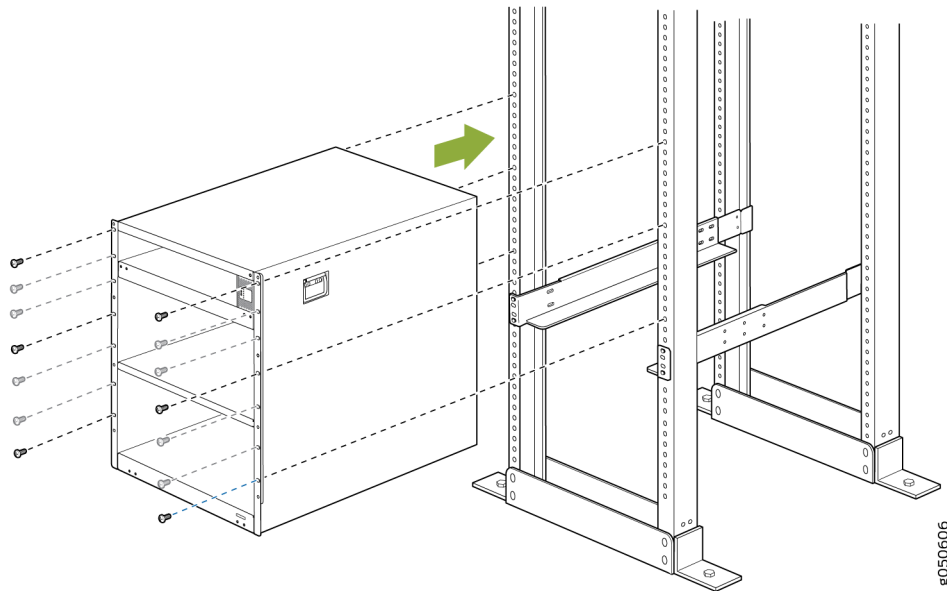


Figure 77: Lifting the QFX10008 Without Using a Mechanical Lift



4. Carefully slide the switch onto the base and rear mounting brackets until the chassis flanges contact the rack rails. The mounting brackets ensure that the holes in the flanges align with the holes in the rack rails. See [Figure 78 on page 207](#).
5. Attach the chassis to the rack by installing a mounting screw through the open flange holes and rack, starting from the bottom.
6. Visually inspect the alignment of the chassis. If the chassis is installed properly in the rack, all the mounting screws on one side of the rack are aligned with the mounting screws on the opposite side and the switch is level.
7. After ensuring that the switch is aligned properly, tighten the screws.

Figure 78: Installing a QFX10008 in a 4-Post Rack



After you install the mounting screws and securely bolt the chassis to the rack, reinstall the components in the chassis. See:

- ["Installing a QFX10000 Line Card" on page 313](#)
- ["Installing a QFX10000 Switch Interface Board" on page 303](#)
- ["Installing a QFX10008 Fan Tray" on page 237](#)
- ["How to Install a QFX10000-PWR-AC Power Supply" on page 248](#) or ["How to Install a QFX10000-PWR-DC Power Supply" on page 271](#)

### RELATED DOCUMENTATION

| [Connecting the QFX10008 or QFX10016 to Power | 213](#)

## Installing the Front Panel on a QFX10000

The front panel is required on the QFX10008 and QFX10016 to protect fiber optic cabling and to provide additional protection from electromagnetic interference (EMI). The front panel can be installed with or without the optional cable management system.

Ensure you have the following tools and parts before you begin:

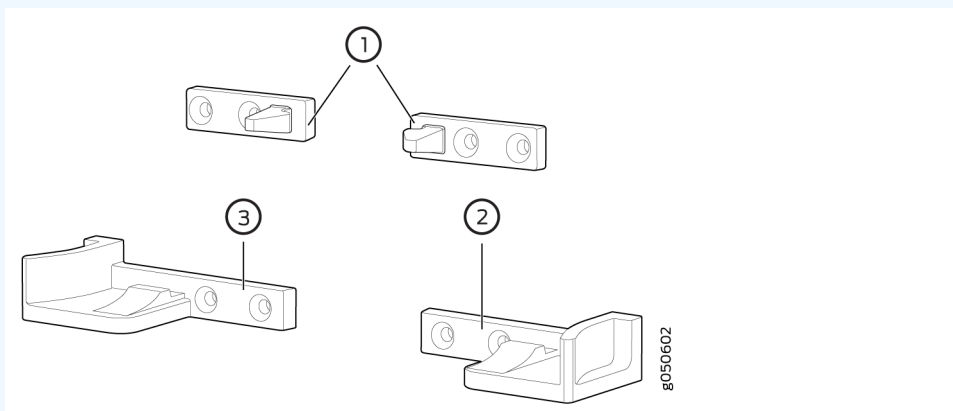
- A Phillips (+) screwdriver, number 2
- Front panel (provided with the switch chassis)
- Right base bracket (provided)
- Left base bracket (provided)
- 2 interchangeable latch brackets (provided)
- 8 Phillips flat-head mounting screws (provided)

To install the front panel:

1. Remove the plastic bag that is taped to the front panel, which holds the brackets and screws.
2. Use the Phillips screwdriver to attach two mounting screws to the left base bracket at the bottom left side of the chassis frame. The base brackets are larger than the latch brackets.

**NOTE:** The right and left base bracket cannot be interchanged (see [Figure 79 on page 208](#)).

**Figure 79: Front Panel Mounting Hardware**



1– Latch brackets

3– Left base bracket

2– Right base bracket

3. Use the Phillips screwdriver to attach two mounting screws to the right base bracket at the bottom right side of the chassis frame.
4. Use the Phillips screwdriver to attach two mounting screws to the latch bracket at the top left of the chassis frame (see [Figure 80 on page 209](#) for QFX10008 and for QFX10016 installations).

Figure 80: Attaching Front Panel Brackets on a QFX10008

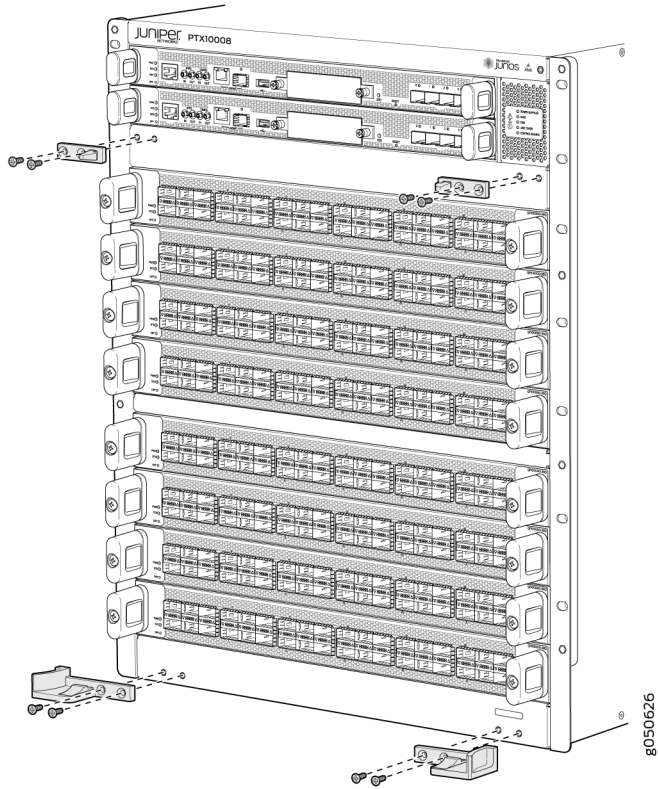
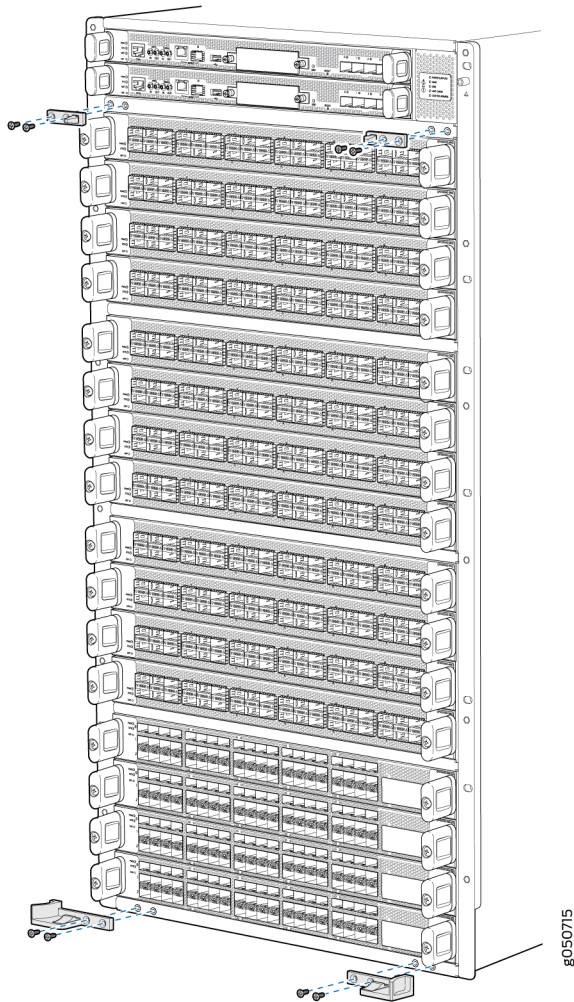


Figure 81: Attaching Front Panel Brackets on a QFX10016



5. Use the final two mounting screws to attach a latch bracket to the top right of the chassis frame so there are brackets on all four corners of the front of the chassis.
6. Lift the front panel and rest it on the two bottom brackets.
7. Slide the panel back on the bracket glides until it engages on the two ramps.
8. Tilt the panel towards the chassis until it is vertical with the chassis. The blue release buttons on the side of the panel click into place (see [Figure 82 on page 211](#) for QFX10008 and [Figure 83 on page 212](#) for QFX10016).

Figure 82: Front Panel Installation on a QFX10008

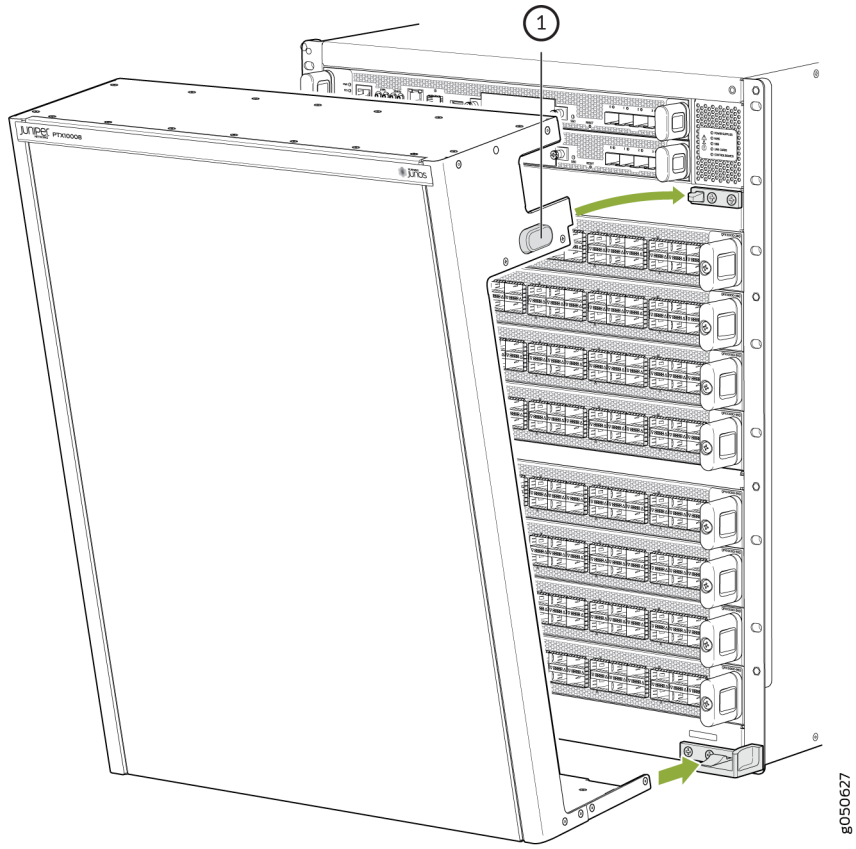
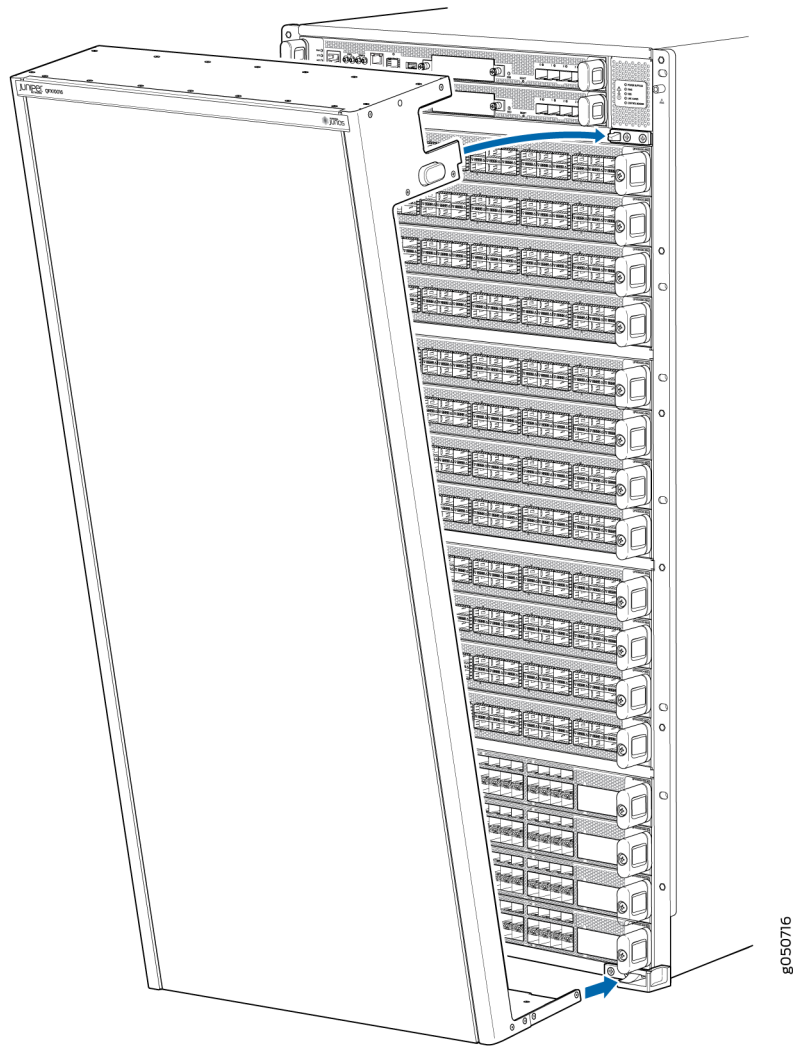


Figure 83: Front Panel Installation on a QFX10016



#### RELATED DOCUMENTATION

[QFX10000 EMI Front Panel | 27](#)

[QFX10000 Optional Equipment | 29](#)

# Connecting the QFX10008 or QFX10016 to Power

## IN THIS SECTION

- [Connect the QFX10008 or QFX10016 to Earth Ground | 213](#)
- [Connect AC Power to a QFX Modular Chassis | 217](#)
- [Connect DC Power to a QFX10008 or QFX10016 | 217](#)

QFX10008 and QFX10016 switches support both AC and DC power supplies. Additionally, QFX modular chassis switches also support high voltage alternating current (HVAC) and high voltage direct current (HVDC) power supplies.

**NOTE:** Do not mix power supply models in the same chassis in a running environment. DC and HVDC can coexist in the same chassis during the hot swap of DC for HVDC.

## Connect the QFX10008 or QFX10016 to Earth Ground

To ensure proper operation and to meet safety and electromagnetic interference (EMI) requirements, you must connect the chassis to earth ground before you connect power to the device.

You must install the QFX10008 and QFX10016 in a restricted-access location and ensure that the chassis is always properly grounded. The QFX10008 and QFX10016 has a two-hole protective grounding terminal provided on the chassis. See [Figure 86 on page 216](#). Under all circumstances, use this grounding connection to ground the chassis. For AC-powered systems, you must also use the grounding wire in the AC power cord along with the two-hole grounding lug connection. This tested system meets or exceeds all applicable EMC regulatory requirements with the two-hole protective grounding terminal.

Ensure that a licensed electrician has attached an appropriate grounding lug to the grounding cable you supply. Using a grounding cable with an incorrectly attached lug can damage the switch.



**NOTE:** Mount your switch in the rack before attaching the grounding lug to the switch. For the QFX10008, see ["Mounting a QFX10008 in a 4-Post Rack Using a Mechanical Lift" on page 200](#) or ["Manually Mounting a QFX10008 in a 4-Post Rack" on page 203](#).

For the QFX10016, see ["Mounting a QFX10016 in a Four-Post Rack Using a Mechanical Lift"](#).

Ensure that you have the following parts and tools available:

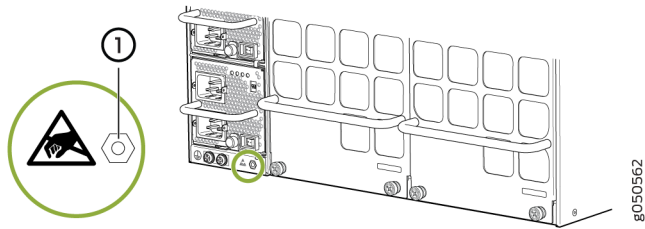
- An electrostatic discharge (ESD) grounding strap (provided).
- Protective earthing terminal lug (provided).
- Grounding cable for your chassis (not provided)—The grounding cable must be 6 AWG (13.3 mm<sup>2</sup>), minimum 90° C wire, or as permitted by the local code.
- Grounding lug for your grounding cable (provided)—This bracket attaches to the lower left corner of the chassis next to **PSU 5** on the QFX10008 and **PSU 9** on the QFX10016. The grounding lug required is a Panduit LCD6-10A-L or equivalent.
- A Phillips screwdriver to tighten the two screws that are mounted on the chassis (not provided).

An AC-powered QFX modular chassis gains additional grounding when you plug the power supply in the switch into a grounded AC power outlet by using an AC power cord appropriate for your geographical location.

To connect earth ground to a QFX10008 or QFX10016 chassis:

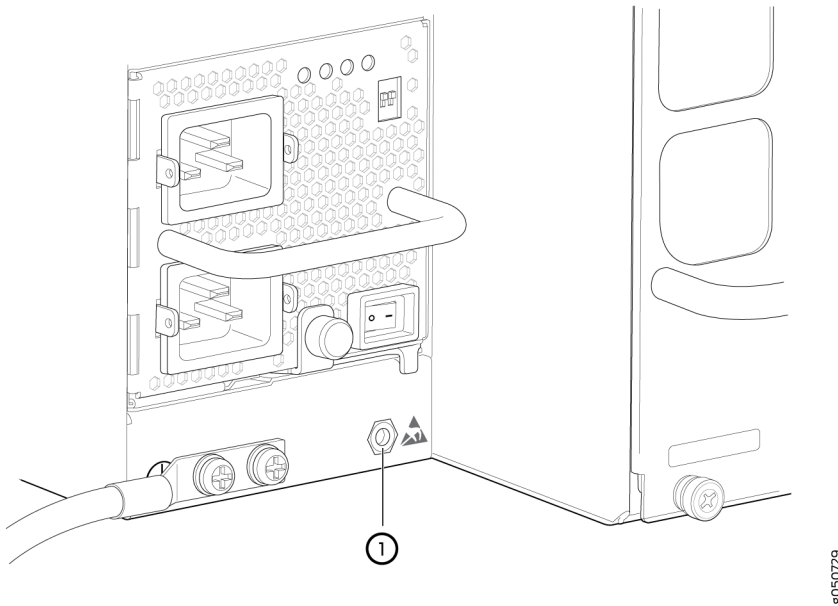
1. Verify that a licensed electrician has attached the cable lug (provided in the accessory kit) to the grounding cable.
2. Connect the other end of the grounding cable to a proper earth ground, such as the rack in which the switch is mounted.
3. Attach an ESD grounding strap to your bare wrist, and connect the strap to the ESD grounding point next to the earthing posts (see [Figure 84 on page 215](#) and [Figure 85 on page 215](#)).

Figure 84: ESD Point for the QFX10008



1- Grounding point

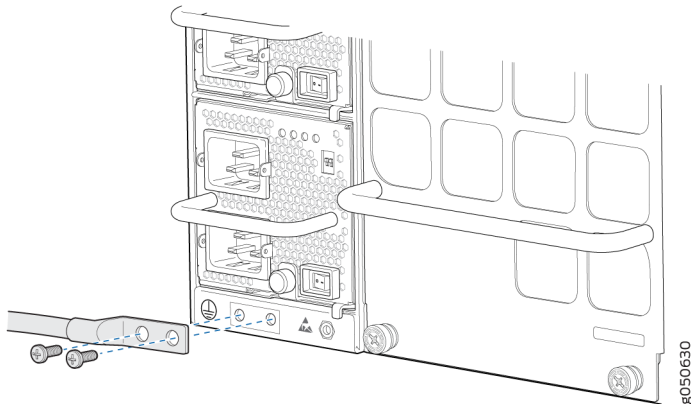
Figure 85: ESD Point for the QFX10016



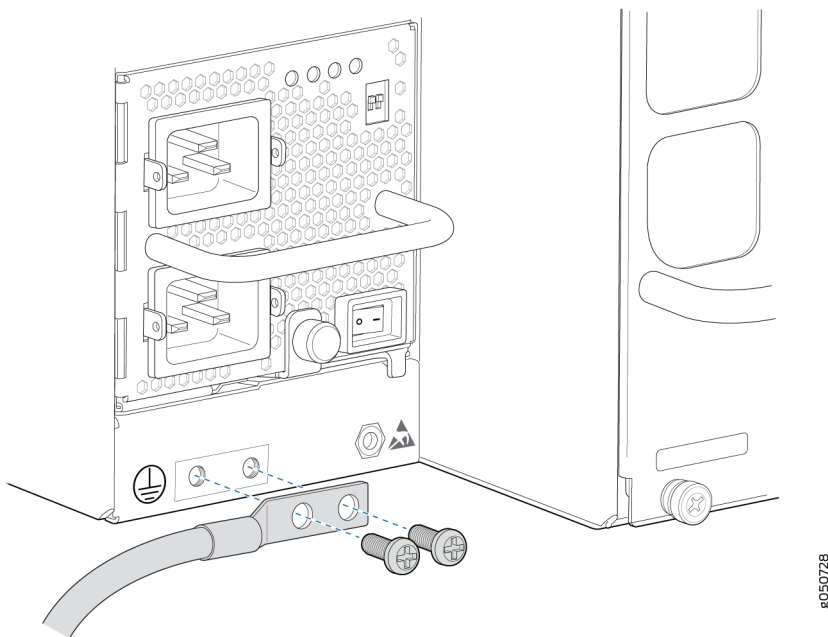
1- Grounding point

4. Remove the two screws on the chassis using a Phillips screwdriver.
5. Place the chassis grounding lug and cable over the PEM nuts with the cable connection pointing to the left. See [Figure 86 on page 216](#) and [Figure 87 on page 216](#).

**Figure 86: Connecting a Grounding Cable to the QFX10008**



**Figure 87: Connecting a Grounding Cable to the QFX10016**



6. Place the two screws over the grounding lug and grounding cable.
7. Tighten the two screws using a Phillips screwdriver.
8. Dress the grounding cable and ensure that it does not touch or block access to other device components and that it does not drape where people can trip over it.

#### SEE ALSO

*General Safety Guidelines and Warnings*

## Connect AC Power to a QFX Modular Chassis

Before you begin to connect power to the switch, be sure you understand how to prevent ESD damage. See [Prevention of Electrostatic Discharge Damage](#).

After you ground the chassis, add power supplies, and supply power to the chassis, the system initiates the power-on sequence. This sequence can start incrementally with a single power supply, but it is not recommended that you bring up a QFX system with less than three power supplies.

To connect AC power to a QFX modular chassis:

1. Connect the chassis to earth ground (see ["Connect the QFX10008 or QFX10016 to Earth Ground" on page 213](#)).



**CAUTION:** To meet safety and electromagnetic interference (EMI) requirements and to ensure proper operation, a QFX modular chassis must be adequately grounded before it is connected to power.

For installations that require a separate grounding conductor to the chassis, use the protective earthing terminal on the rear panel of the QFX10008 or QFX10016 to connect to the earth ground.

A QFX modular chassis gets additional grounding when you plug the power supply in the switch into a grounded AC power outlet by using the AC power cord appropriate for your geographical location. See ["QFX10000 Power Cables Specifications" on page 52](#).

2. Install power supplies in the switch and apply power. See ["How to Install a QFX10000-PWR-AC Power Supply" on page 248](#) and ["How to Install a JNP10K-PWR-AC2 Power Supply" on page 260](#).

## Connect DC Power to a QFX10008 or QFX10016

The overall process of bringing up a DC-powered chassis involves the proper cabling of the individual power supplies, adding the power supplies to the chassis, and supplying power. The power-on sequence can start incrementally with a single power supply, but it is not recommended that you bring up a QFX modular chassis system with less than three power supplies.

Each power supply input feed must be connected to a dedicated DC power source outlet.

Before you begin to connect power to the switch be sure you understand how to prevent electrostatic discharge (ESD) damage. See [Prevention of Electrostatic Discharge Damage](#).

To connect DC power to a QFX10000-PWR-DC power supply, see "[How to Install a QFX10000-PWR-DC Power Supply](#)" on page 271. To connect DC power to a JNP10K-PWR-DC2 power supply, see "[How to Install a JNP10K-PWR-DC2 Power Supply](#)" on page 287.

1. Ensure the chassis is properly grounded.



**CAUTION:** To meet safety and electromagnetic interference (EMI) requirements and to ensure proper operation, a QFX modular chassis must be adequately grounded before it is connected to power.

2. Connect DC power to each DC power supply, see "[How to Install a QFX10000-PWR-DC Power Supply](#)" on page 271.

Each power supply input feed must be connected to a dedicated DC power source outlet.

#### SEE ALSO

[QFX10000 DC Power System | 65](#)

[Prevention of Electrostatic Discharge Damage](#)

#### RELATED DOCUMENTATION

[Maintaining QFX10000 Power System | 243](#)

## Connecting the QFX10000 to External Devices

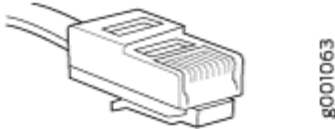
#### IN THIS SECTION

- [Connect a Device to a Network for Out-of-Band Management | 219](#)
- [Connect a Device to a Management Console Using an RJ-45 Connector | 219](#)

## Connect a Device to a Network for Out-of-Band Management

Ensure that you have an Ethernet cable that has an RJ-45 connector at either end. [Figure 88 on page 219](#) shows the RJ-45 connector of the Ethernet cable.

**Figure 88: RJ-45 Connector on an Ethernet Cable**

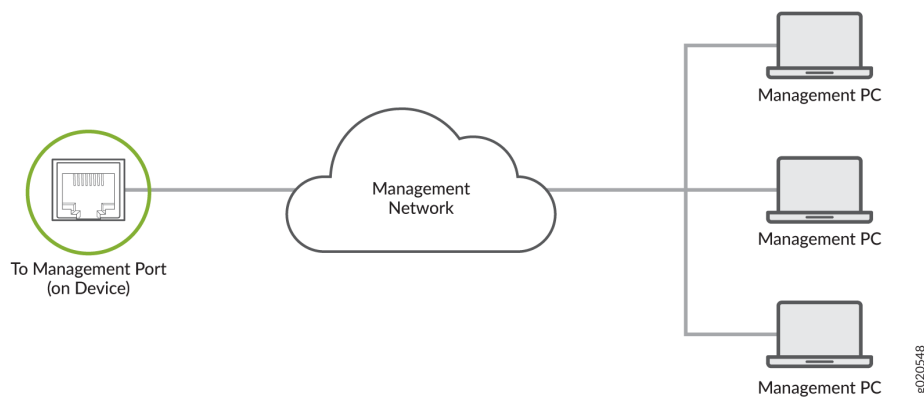


You can monitor and manage these devices by using a dedicated management channel. Each device has a management port to which you can connect an Ethernet cable with an RJ-45 connector. Use the management port to connect the device to the management device.

To connect a device to a network for out-of-band management (see [Figure 89 on page 219](#)):

1. Connect one end of the Ethernet cable to the management port on the device.
2. Connect the other end of the Ethernet cable to the management device.

**Figure 89: Connect a Device to a Network for Out-of-Band Management**

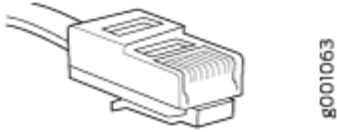


## Connect a Device to a Management Console Using an RJ-45 Connector

Ensure that you have an Ethernet cable that has an RJ-45 connector at either end and an RJ-45-to-DB-9 serial port adapter.

Figure 90 on page 220 shows the RJ-45 connector on the Ethernet cable.

**Figure 90: RJ-45 Connector on an Ethernet Cable**



**NOTE:** We no longer include the RJ-45 console cable with the DB-9 adapter as part of the device package. If the console cable and adapter are not included in your device package, or if you need a different type of adapter, you can order the following separately:

- RJ-45 to DB-9 adapter (JNP-CBL-RJ45-DB9)
- RJ-45 to USB-A adapter (JNP-CBL-RJ45-USBA)
- RJ-45 to USB-C adapter (JNP-CBL-RJ45-USBC)

If you want to use RJ-45 to USB-A or RJ-45 to USB-C adapter you must have X64 (64-Bit) Virtual COM port (VCP) driver installed on your PC. See, <https://ftdichip.com/drivers/vcp-drivers/> to download the driver.

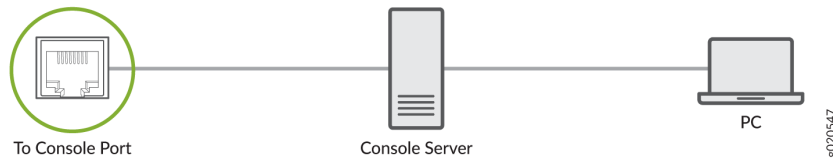
**NOTE:** If your laptop or desktop PC does not have a DB-9 plug connector pin and you want to connect your laptop or desktop PC directly to the device, use a combination of the RJ-45-to-DB-9 socket adapter and a USB-to-DB-9 plug adapter. You must provide the USB-to-DB-9 plug adapter.

You can configure and manage your network devices using a dedicated management channel. Each device has a console port that you can connect to using an Ethernet cable with an RJ-45 connector. Use the console port to connect the device to the console server or management console. The console port accepts a cable that has an RJ-45 connector.

To connect the device to a management console (see [Figure 91 on page 221](#) and [Figure 92 on page 221](#)):

1. Connect one end of the Ethernet cable to the console port (labeled **CON**, **CONSOLE**, or **CON1**) on the device.
2. Connect the other end of the Ethernet cable to the console server (see [Figure 91 on page 221](#)) or management console (see [Figure 92 on page 221](#)).

**Figure 91: Connect a Device to a Management Console Through a Console Server**



**Figure 92: Connect a Device Directly to a Management Console**



## RELATED DOCUMENTATION

[QFX10000 Console and Management Cable Specifications and Pinouts](#) | 179

# Performing an Initial Configuration of a QFX10000

Before you begin connecting and configuring the switch, set the following parameter values on the console server or PC:

- Baud Rate—9600
- Flow Control—None
- Data—8
- Parity—None
- Stop Bits—1
- DCD State—Disregard

You must perform the initial configuration of a QFX10000 modular switch through the console port using the command-line interface (CLI) or through Zero Touch Provisioning (ZTP). On QFX10002 fixed-



chassis models, in addition to using the CLI, you may also use ZTP. In order to provision the QFX10002 using ZTP, you must have access to a Dynamic Host Control Protocol (DHCP) server and a File Transfer Protocol (anonymous FTP), Hypertext Transfer Protocol (HTTP), or Trivial File Transfer Protocol (TFTP) server on which the software image and configuration files are stored. For more information about using ZTP for provisioning the device, see [Zero Touch Provisioning Overview](#).

The following procedure sets up the QFX10000 using the command-line interface (CLI).

To connect and configure the switch from the console:

1. Connect the console port to a laptop or PC using an RJ-45 cable and RJ-45 to DB-9 adapter. The console (**CON**) port is located on the port panel of the switch.
2. Log in as **root**. There is no password. If the software booted before you connected to the console port, you might need to press the Enter key for the prompt to appear.

```
login: root
```

3. Start the CLI.

```
root@% cli
```

4. Enter configuration mode.

```
root> configure
```

5. Add a password to the root administration user account.

```
[edit]  
root@# set system root-authentication plain-text-password  
New password: password  
Retype new password: password
```

6. (Optional) Configure the name of the switch. If the name includes spaces, enclose the name in quotation marks (" ").

```
[edit]  
root@# set system host-name host-name
```

7. Configure the default gateway.

```
[edit]
root@# set routing-options static route default next-hop address
```

8. Configure the IP address and prefix length for the switch management interface.

```
[edit]
root@# set interfaces em0 unit 0 family inet address address/prefix-length
```



**CAUTION:** Although the CLI permits you to configure two management Ethernet interfaces within the same subnet, only one interface is usable and supported.

**NOTE:** The management ports, `em0` (**MGMT** for RJ-45 connections) and `em1` (also labeled **MGMT** for fiber connections), are found on the port panel of the QFX10002 and on each of the Routing and Control Boards of the QFX10008 and QFX10016.

**NOTE:** We no longer include the RJ-45 console cable with the DB-9 adapter as part of the device package. If the console cable and adapter are not included in your device package, or if you need a different type of adapter, you can order the following separately:

- RJ-45 to DB-9 adapter (JNP-CBL-RJ45-DB9)
- RJ-45 to USB-A adapter (JNP-CBL-RJ45-USBA)
- RJ-45 to USB-C adapter (JNP-CBL-RJ45-USBC)

If you want to use RJ-45 to USB-A or RJ-45 to USB-C adapter you must have X64 (64-Bit) Virtual COM port (VCP) driver installed on your PC. See, <https://ftdichip.com/drivers/vcp-drivers/> to download the driver.

9. (Optional) Configure the static routes to remote prefixes with access to the management port.

```
[edit]
root@# set routing-options static route remote-prefix next-hop destination-ip retain no-readvertise
```

10. Enable Telnet service.

```
[edit]  
root@# set system services telnet
```

**NOTE:** When Telnet is enabled, you cannot log in to a QFX10000 through Telnet using root credentials. Root login is allowed only for SSH access.

11. Commit the configuration to activate it on the switch.

```
[edit]  
root@# commit
```

## RELATED DOCUMENTATION

[QFX10008 Installation Overview | 186](#)

[QFX10002 System Overview](#)

# 4

CHAPTER

## Maintaining Components

---

Handling and Storing QFX10000 Line Cards, RCBs, and SIBs | 226

Maintaining QFX10000 Routing and Control Boards | 230

Maintaining QFX10008 Cooling System | 235

Maintaining QFX10000 Power System | 243

Maintaining QFX10000 Switch Interface Boards | 298

Maintaining QFX10000 Line Cards | 309

Maintaining QFX10000 Solid State Drives | 319

Maintaining Transceivers and Fiber-Optic Cables on QFX10000 | 323

Removing the QFX10008 | 331

---

# Handling and Storing QFX10000 Line Cards, RCBs, and SIBs

## IN THIS SECTION

- [Holding Line Cards and RCBs | 226](#)
- [Holding SIBs | 227](#)
- [Storing Line Cards, RCBs, and SIBs | 229](#)

The QFX10008 and QFX10016 chassis have several field-replaceable units (FRUs) that have fragile components. To avoid damaging the line cards, Routing and RCBs (RCBs), and Switch Interface Boards (SIBs), be sure you follow the following safe handling practices. This topic covers:

## Holding Line Cards and RCBs

Pay proper attention to the way you are holding line cards and RCBs. These FRUs are installed horizontally and it is best to hold them by the sides of the units when they are not in the chassis.

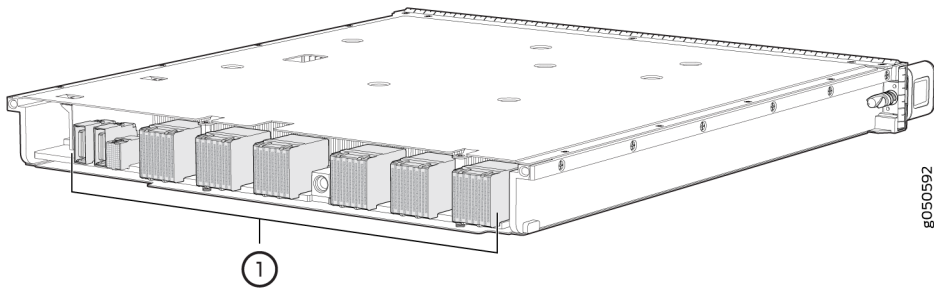
When walking with a line card or RCB:

1. Orient the line card or the RCB so that the faceplate is toward you.
2. Grasp each side of the unit firmly as you slide the unit out of the chassis.
3. Take care not to strike the unit against any object as you carry it.



**CAUTION:** Never hold the line card or RCB by the connector edge. The connectors are fragile and the line card or RCB will not seat properly if the connector is damaged. See [Figure 93 on page 227](#).

Figure 93: Connector Edge of a Line Card



1– Connectors

4. If you must rest a line card or RCB on an edge, place a cushion between the edge and the surface.

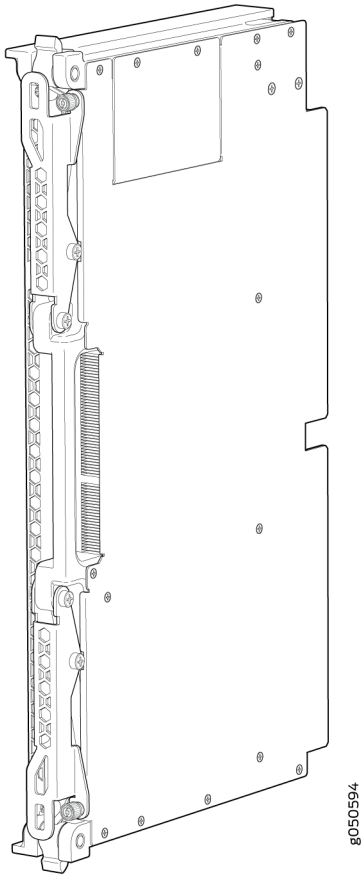


**CAUTION:** Do not stack line cards or RCBs on top of one another or on top of any other component.

5. Place each line card separately in an electrostatic bag or on an antistatic mat placed on a flat, stable surface.

## Holding SIBs

SIBs are installed vertically and should be held vertically until they are clear of the switch before rotating them 90 degrees and placing them on an antistatic mat or placing them in an electrostatic bag for storage. See [Figure 94 on page 228](#).

**Figure 94: QFX10000 SIB**

The proper method of holding a SIB is to:

1. Hold the SIB by the ejectors while you keep the SIB vertical, and slide the SIB about three-quarters of the way out of the chassis.
2. Place one hand underneath the SIB to support it, and slide it completely out of the chassis.



**CAUTION:** Never hold the SIB by the connector edge. The connectors are fragile and the SIB will not align and seat properly if the connector is damaged.



**CAUTION:** Do not stack SIBs on top of one another or on top of any other component.

## Storing Line Cards, RCBs, and SIBs

You must store line cards, RCBs, and SIBs either in the chassis or in a spare shipping container, horizontally and sheet metal side down. Do not stack these units on top of one another or on top of any other component. Place each unit separately in an antistatic bag or on an antistatic mat placed on a flat, stable surface.



**WARNING:** Never place any material, such as port dust caps, on top of an installed line card because the system fans can pull the material into the chassis.

**NOTE:** Because these units are heavy, and because electrostatic bags are fragile, inserting the line card into the bag is best done with two people.

To insert a line card, RCB, or SIB into an electrostatic bag:

1. Hold the unit horizontally with the faceplate toward you.
2. Slide the opening of the bag over the connector edge.

If you must insert the line card, RCB, or SIB into a bag by yourself:

1. Lay the unit horizontally on an antistatic mat that is on a flat, stable surface with the sheet metal side down.
2. Orient the unit with the faceplate toward you.
3. Carefully insert the connector edge into the opening of the bag and pull the bag toward you to cover the unit.

### RELATED DOCUMENTATION

[QFX10000 Line Cards | 88](#)

[QFX10008 Switch Interface Board | 77](#)

[QFX10000 Routing and Control Board | 81](#)



# Maintaining QFX10000 Routing and Control Boards

## IN THIS SECTION

- [Removing a QFX10000 Routing and Control Board | 230](#)
- [Installing a QFX10000 Routing and Control Board | 232](#)

## Removing a QFX10000 Routing and Control Board

The QFX10000 line of modular chassis can have one or two Routing and Control Boards (RCBs), depending on the configuration. RCBs can be installed in either of the two top slots on the front of the chassis.

In redundant configurations, a QFX10000 RCB is a hot-removable and hot-insertable field-replaceable unit (FRU). In base configurations, you need to install a second RCB before removing a failing RCB in order to prevent the switch from shutting down. We recommend that you take base systems offline before replacing the RCB.

Before you remove an RCB, ensure that you have an electrostatic discharge (ESD) grounding strap.



**CAUTION:** In base configurations, removal of the RCB causes the system to shut down. In redundant configurations, removal of the RCB causes the system to reboot and start the election process for a new primary.

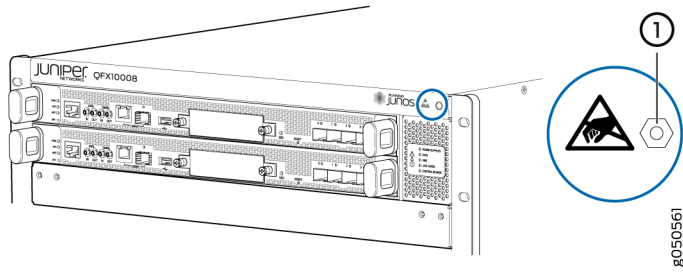
To remove an RCB:

1. Take the RCB offline.

Place an electrostatic bag or antistatic mat on a flat, stable surface.

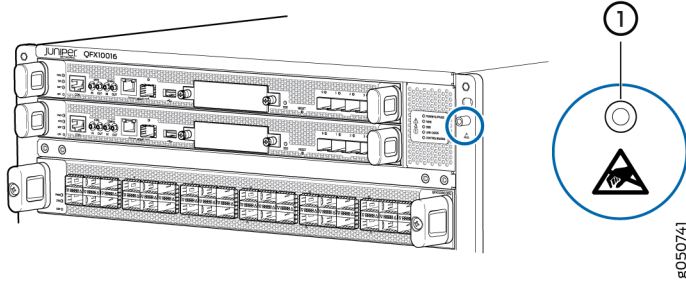
2. Attach the ESD grounding strap to your bare wrist, and connect the strap to the ESD point on the chassis (see [Figure 95 on page 231](#) and [Figure 96 on page 231](#)).

Figure 95: ESD Point on QFX10008 Chassis Front



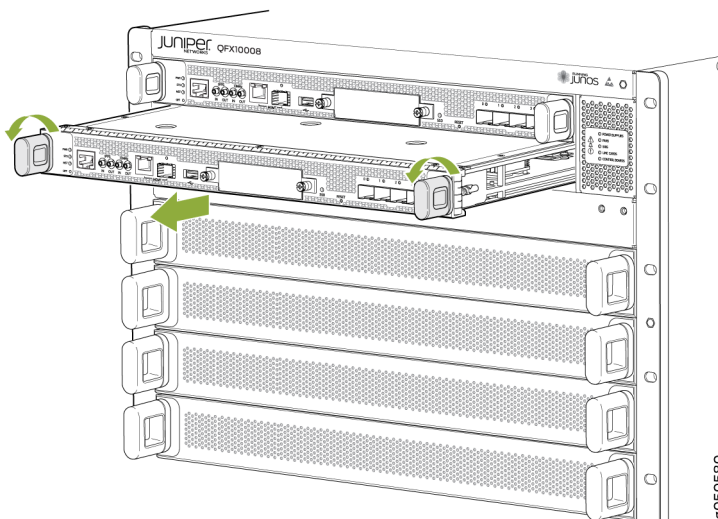
1- ESD point

Figure 96: ESD Point on QFX10016 Chassis Front



- 3. Simultaneously rotate the RCB handles counterclockwise to unseat the RCB.
- 4. Grasp the handles and slide the RCB about halfway out of the chassis (see [Figure 97 on page 231](#)).

Figure 97: Removing an RCB



5. Grasp each side of the RCB and slide it completely out of the chassis.
6. Place the RCB on the antistatic mat.
7. If you are not replacing the RCB now, install a cover in the empty slot.

## Installing a QFX10000 Routing and Control Board

The QFX10000 line of modular chassis can have one or two Routing and Control Boards (RCBs), depending on the configuration. RCBs can be installed in either of the two top slots on the front of the chassis.

In redundant configurations, a QFX10000 RCB is a hot-removable and hot-insertable field-replaceable unit (FRU). In base configurations, you need to install a second RCB before removing a failing RCB in order to prevent the switch from shutting down.

Before you install a RCB, ensure that you have an electrostatic discharge (ESD) grounding strap.

To install a RCB:

1. Attach the ESD grounding strap to your bare wrist, and connect the strap to the ESD point on the front of the chassis (see [Figure 98 on page 232](#) and [Figure 99 on page 233](#)).

**Figure 98: ESD Point for QFX10008 Chassis Front**

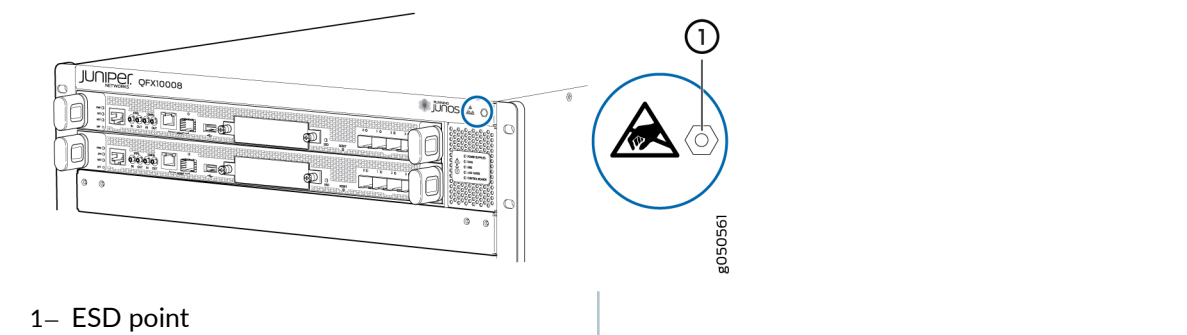
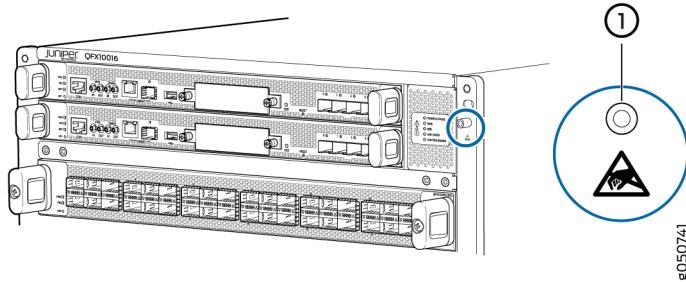
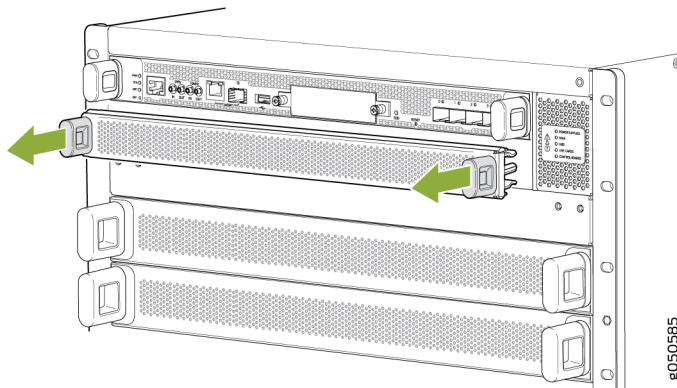


Figure 99: ESD Point for QFX10016 Chassis Front



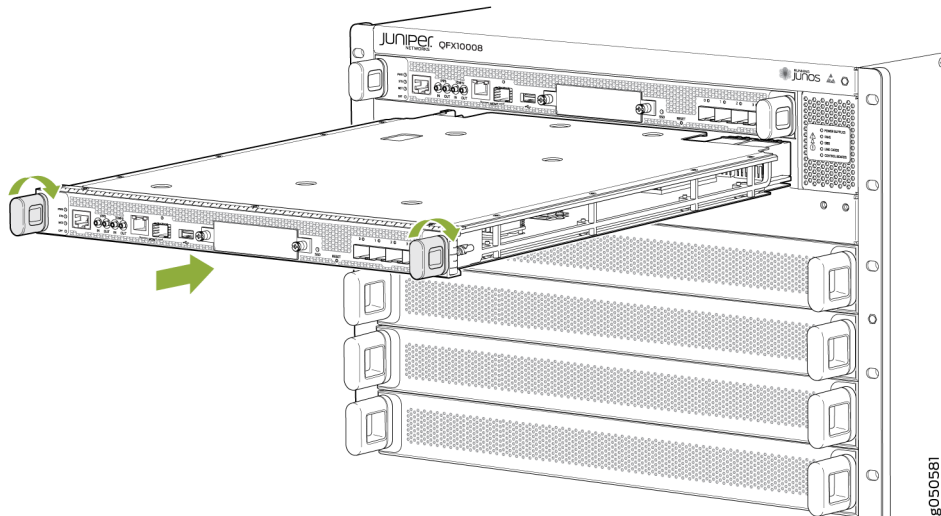
2. Either remove the cover from the available RCB slot (see [Figure 100 on page 233](#)) or remove the failing RCB (see "[Removing a QFX10000 Routing and Control Board](#)" on page 230).

Figure 100: Removing a RCB Cover Panel



3. Remove the new RCB from the electrostatic bag and inspect it for any damage before installing it into the chassis.
4. Lift the RCB by its sides, being careful not to bump the connectors.
5. Carefully align the sides of the RCB with the guides inside the chassis.
6. Slide the RCB into the chassis, carefully ensuring that it is correctly aligned.
7. Grasp both handles and rotate them simultaneously clockwise until the RCB is fully seated and the handles are vertical (see [Figure 101 on page 234](#)).

Figure 101: RCB Installation



The RCB begins the power-on sequence when fully seated.

8. To verify that the RCB is functioning normally, check the **PWR** LED on its faceplate and the **CONTROL BOARDS** LED on the status panel. Both LEDs should light steadily shortly after the RCB is installed. If the **PWR** LED is blinking yellow, there might be insufficient power available. See ["Power Requirements for QFX10000 Components" on page 163](#) to ensure that you have adequate power for the additional unit.

Another method of verifying that the RCB is online is to use the CLI command:

```
user@host> show chassis environment cb
```

## RELATED DOCUMENTATION

[QFX10000 Routing and Control Board | 81](#)

[Power Requirements for QFX10000 Components | 163](#)

[QFX10000 Routing and Control Board LEDs | 83](#)

# Maintaining QFX10008 Cooling System

## IN THIS SECTION

- [Removing a QFX10008 Fan Tray | 235](#)
- [Installing a QFX10008 Fan Tray | 237](#)
- [Removing a QFX10008 Fan Tray Controller | 239](#)
- [Installing a QFX10008 Fan Tray Controller | 241](#)

Both QFX10008 and QFX10016 switches have two independent, field-replaceable fan trays, each with an associated fan tray controller.

## Removing a QFX10008 Fan Tray

Before you remove a fan tray:

- Ensure you understand how to prevent ESD damage. See [Prevention of Electrostatic Discharge Damage](#).
- Ensure that you have the following parts and tools available to remove a fan tray from a QFX10008 chassis:
  - Electrostatic discharge (ESD) grounding strap
  - Replacement fan tray
  - A Phillips (+) screwdriver, number 1 or 2 (optional), for the captive screws

The QFX10008 chassis has two independent, field-replaceable fan trays. Each fan tray is a hot-removable and hot-insertable field-replaceable unit (FRU); you can remove and replace the fan tray while the switch is running without turning off power to the switch or disrupting switching functions.



**CAUTION:** Do not remove the fan tray unless you have a replacement fan tray available.

Each fan tray is installed vertically on the rear, or FRU-side, of the chassis.

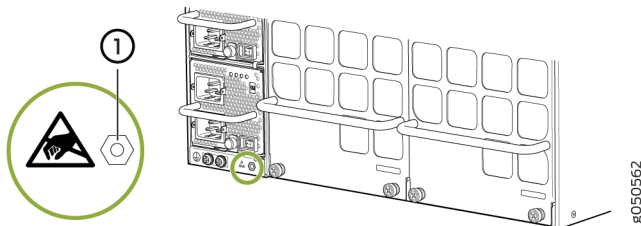


**CAUTION:** The fan tray can be removed and replaced while the switch is operating. However, the fan tray must be replaced within 3 minutes of removing the fan tray to prevent overheating of the chassis.

To remove a QFX10000 fan tray (see [Figure 103 on page 237](#) for the QFX10008 chassis):

1. Attach the electrostatic discharge (ESD) grounding strap to your bare wrist, and connect the strap to the ESD point on the rear left side of the chassis. See [Figure 102 on page 236](#).

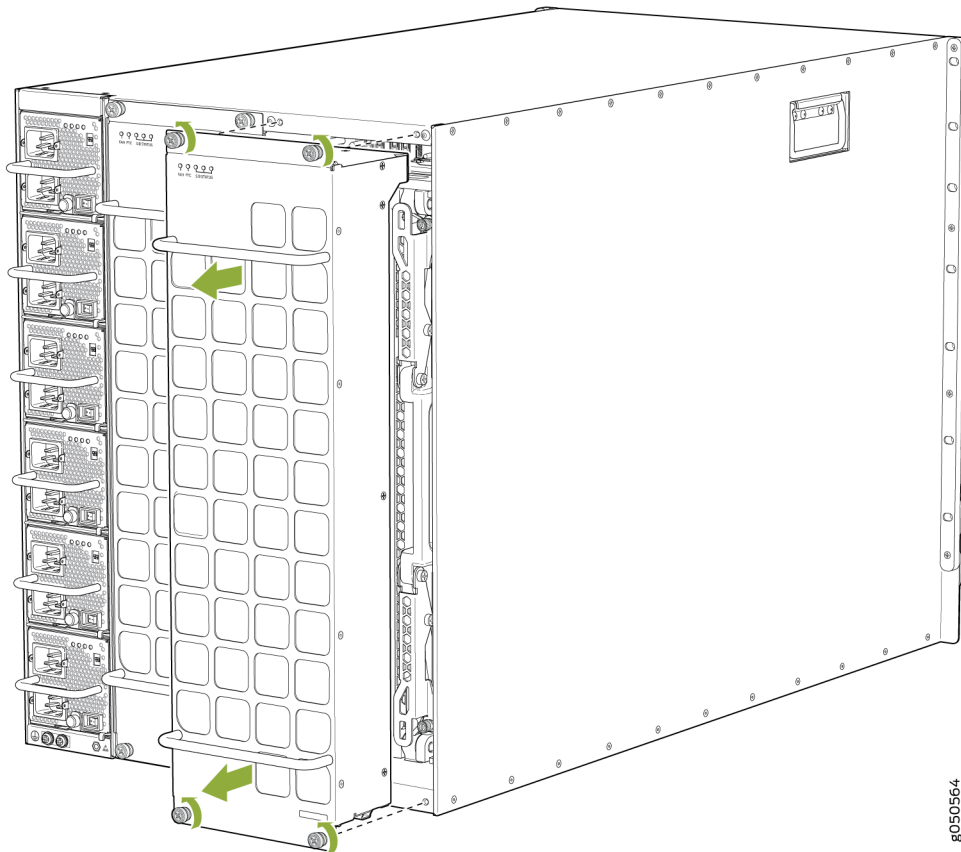
**Figure 102: ESD Point on QFX10008 Chassis Rear**



1– ESD point

2. Loosen the four captive screws either by unscrewing with your thumb and forefinger or with a Phillips screwdriver.
3. Grasp the top and bottom handles and pull the fan tray out about 3 in. (7.6 cm). See [Figure 103 on page 237](#).

Figure 103: Removing a Fan Tray from a QFX10008 Chassis



4. Tilt the top of the fan tray forward.
5. Using both hands, lift the fan tray out of the slot and rest it on a flat surface with the handles to the side.



**CAUTION:** Replace a fan tray within three minutes to avoid chassis overheating.

## Installing a QFX10008 Fan Tray

Before you begin to install a fan tray:

- Ensure you understand how to prevent ESD damage. See [Prevention of Electrostatic Discharge Damage](#).

Ensure that you have the following parts and tools available to install a fan tray in a QFX10008 chassis:



- Electrostatic discharge (ESD) grounding strap
- A Phillips (+) screwdriver, number 1 or 2 (optional), for the captive screws
- A replacement fan tray



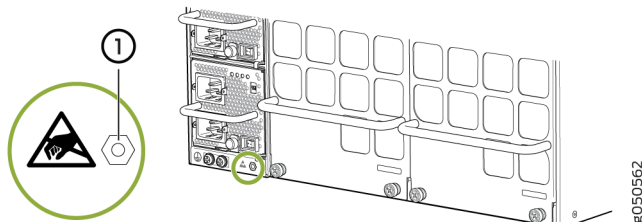
**CAUTION:** The fan tray can be removed and replaced while the switch is operating. However, the fan tray must be replaced within three minutes of removing the fan tray to prevent the chassis from overheating.

The QFX10008 chassis has two independent, field-replaceable fan trays. Each fan tray is a hot-removable and hot-insertable field-replaceable unit (FRU); you can remove and replace the fan tray while the switch is running without turning off power to the switch or disrupting switching functions.

To install a QFX10008 fan tray, see [Figure 105 on page 239](#):

1. Attach the ESD grounding strap to your bare wrist, and connect the strap to the ESD point on the rear left side of the chassis. See [Figure 104 on page 238](#).

**Figure 104: ESD Point for QFX10008 Chassis Rear**



1– ESD point

2. Grasp the top and bottom fan tray handles and align the bottom of the fan tray with the bottom of the fan tray slot.
3. Rest the bottom edge of the fan tray in the slot and slide the fan tray into place so it is fully seated.
4. Tighten the captive screws until finger tight. See [Figure 105 on page 239](#).

Figure 105: Installing a JNP10008-FAN Fan Tray in a QFX10008 Chassis

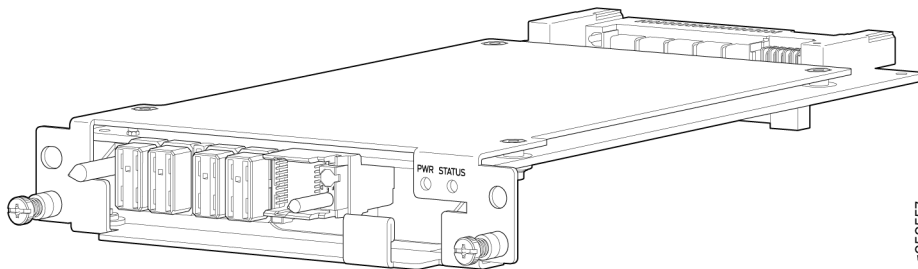


8050565

## Removing a QFX10008 Fan Tray Controller

For each of the two fan trays, there is a fan tray controller. Each controller is a hot-removable and hot-insertable field-replaceable unit (FRU); you can remove and replace one fan tray controller while the switch is running without turning off power to the switch or disrupting switching functions. See [Figure 106 on page 240](#).

Figure 106: QFX10008 Fan Tray Controller



**CAUTION:** Do not remove the fan tray controller unless you have a replacement controller available.

In order to access a fan tray controller, you must first remove the fan tray. With the fan tray removed, the fan tray controller is installed horizontally above the switch interface boards (SIBs) at the top of the chassis.

Before you remove a fan tray controller:

- Ensure you understand how to prevent ESD damage. See "[Prevention of Electrostatic Discharge Damage](#)" on page 394.

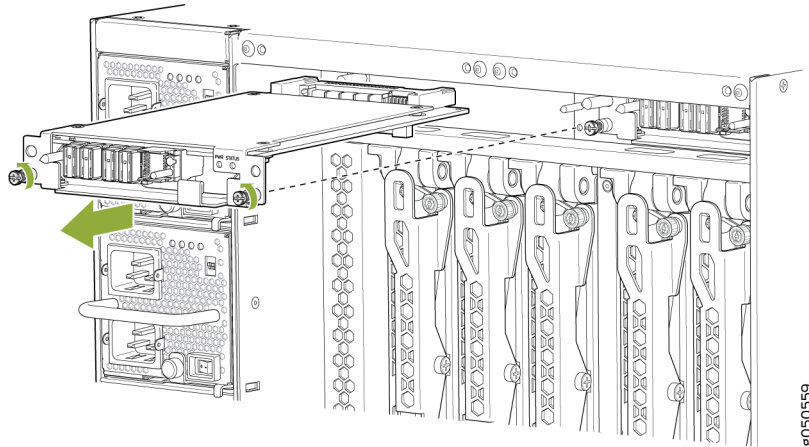
Ensure that you have the following parts and tools available to remove a fan tray controller from a QFX10008 chassis:

- Electrostatic discharge (ESD) grounding strap
- An electrostatic bag or an antistatic mat
- Replacement fan tray controller
- A Phillips (+) screwdriver, number 1, for the captive screws

To remove the fan tray controller:

1. Remove the fan tray. See "[Removing a QFX10008 Fan Tray](#)" on page 235.
2. Loosen the two captive screws on each side of the fan tray controller.
3. Grasp the fan tray controller and pull it straight out of the slot. See [Figure 107](#) on page 241.

Figure 107: Removing a QFX10008 Fan Tray Controller



4. Place the fan tray controller in an electrostatic bag or on an antistatic mat.

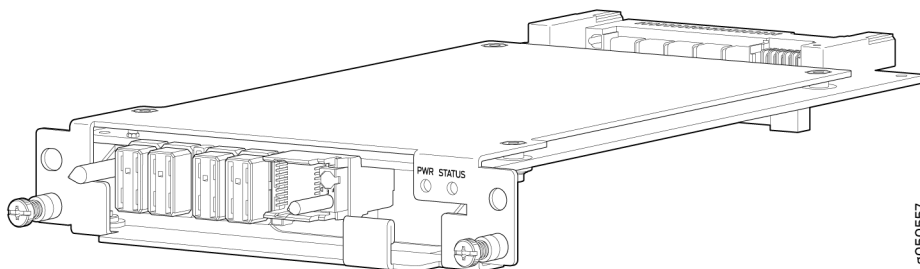
#### SEE ALSO

[QFX10008 Cooling System | 32](#)

## Installing a QFX10008 Fan Tray Controller

For each of the two fan trays, there is a fan tray controller. Each controller is a hot-removable and hot-insertable field-replaceable unit (FRU); you can remove and replace one fan tray controller while the switch is running without turning off power to the switch or disrupting switching functions. See [Figure 108 on page 241](#).

Figure 108: Fan Tray Controller





**CAUTION:** Do not remove the fan tray controller unless you have a replacement controller available.

In order to access a fan tray controller, you must first remove the associated fan tray. With the fan tray removed, the fan tray controller is installed horizontally above the Switch Interface Boards (SIBs) at the top of the chassis.

Before you replace a fan tray controller:

- Ensure you understand how to prevent ESD damage. See "[Prevention of Electrostatic Discharge Damage](#)" on page 394.
- You have removed the associated fan tray and fan tray controller. See "[Removing a QFX10008 Fan Tray](#)" on page 235 and "[Removing a QFX10008 Fan Tray Controller](#)" on page 239.

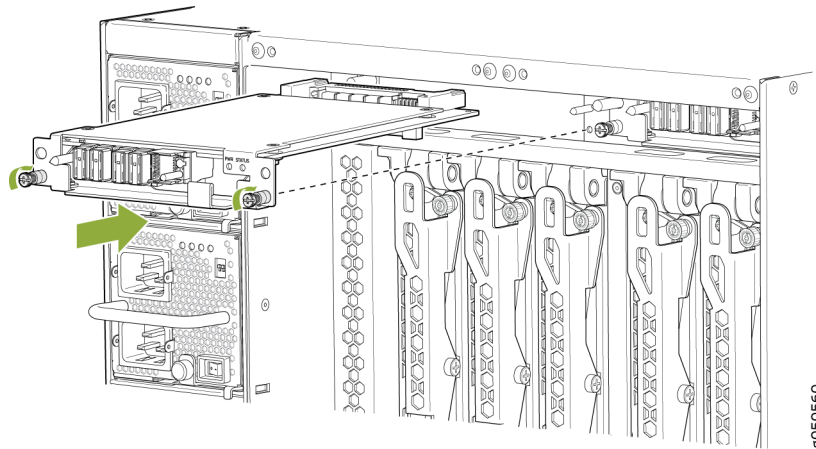
Ensure that you have the following parts and tools available to install a fan tray controller into a QFX10008 chassis:

- Electrostatic discharge (ESD) grounding strap
- Replacement fan tray controller
- A Phillips (+) screwdriver, number 1 for the captive screws

To install a fan tray controller:

1. Remove the replacement fan tray controller from the electrostatic bag.
2. Carefully slide the fan tray controller into the fan tray controller slot until it is flush with the mounting holes. See [Figure 109 on page 243](#).

Figure 109: Replacing a QFX10008 Fan Tray Controller



3. Using a Phillips screwdriver, tighten the captive screws for the fan tray controller.
4. Replace the fan tray. See "[Installing a QFX10008 Fan Tray](#)" on page 237.

#### SEE ALSO

[QFX10000 Fan Tray LEDs and Fan Tray Controller LEDs](#) | 37

#### RELATED DOCUMENTATION

[QFX10008 Cooling System](#) | 32

[QFX10000 Field-Replaceable Units](#) | 23

## Maintaining QFX10000 Power System

#### IN THIS SECTION

- [How to Remove a QFX10000-PWR-AC Power Supply](#) | 244
- [How to Install a QFX10000-PWR-AC Power Supply](#) | 248
- [How to Remove a JNP10K-PWR-AC2 Power Supply](#) | 256
- [How to Install a JNP10K-PWR-AC2 Power Supply](#) | 260

- [How to Remove a QFX10000-PWR-DC Power Supply | 267](#)
- [How to Install a QFX10000-PWR-DC Power Supply | 271](#)
- [How to Remove a JNP10K-PWR-DC2 Power Supply | 283](#)
- [How to Install a JNP10K-PWR-DC2 Power Supply | 287](#)

QFX10008 and QFX10016 routers support both AC and DC power supplies. Additionally, QFX10000 routers support high voltage alternating current (HVAC) or high voltage direct current (HVDC) power supplies. To install and remove the power supplies in a QFX10008 router or a QFX10016 router, refer to the following sections.

## How to Remove a QFX10000-PWR-AC Power Supply

Before you remove a power supply from the chassis:

- Ensure you understand how to prevent ESD damage. See [Prevention of Electrostatic Discharge Damage](#).

Ensure that you have the following parts and tools available to remove an QFX10000-PWR-AC power supply from a QFX10000 switch:

- Electrostatic discharge (ESD) grounding strap
- Phillips (+) screwdriver, number 1
- Replacement power supply or a cover for the power supply slot

The QFX10000-PWR-AC power supply in a QFX10008 and QFX10016 switch chassis is a hot-removable and hot-insertable field-replaceable unit (FRU). You remove all power supplies from the rear of the chassis.



**CAUTION:** Before you remove a power supply, ensure that you have power supplies sufficient to power the switch left in the chassis. See ["Power Requirements for QFX10000 Components"](#) on page 163.

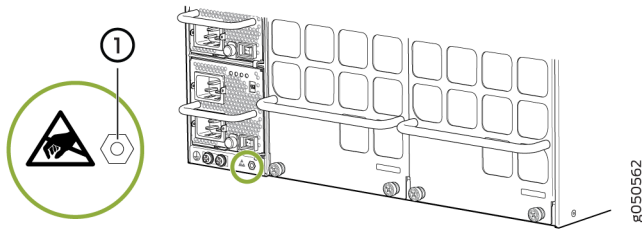


**CAUTION:** Do not leave the power supply slot empty for a long time while the switch is operational. Either replace the power supply promptly or install a cover over the empty slot.

To remove a QFX10000-PWR-AC power supply from a QFX10000 switch:

1. Attach the electrostatic discharge (ESD) grounding strap to your bare wrist, and connect the strap to the ESD point on the chassis. There is an ESD point located next to the protective earthing terminal and below **PSU 5** on the QFX10008 rear panel (see [Figure 110 on page 245](#)) and below **PSU\_9** on the QFX10016 (see [Figure 111 on page 246](#)).

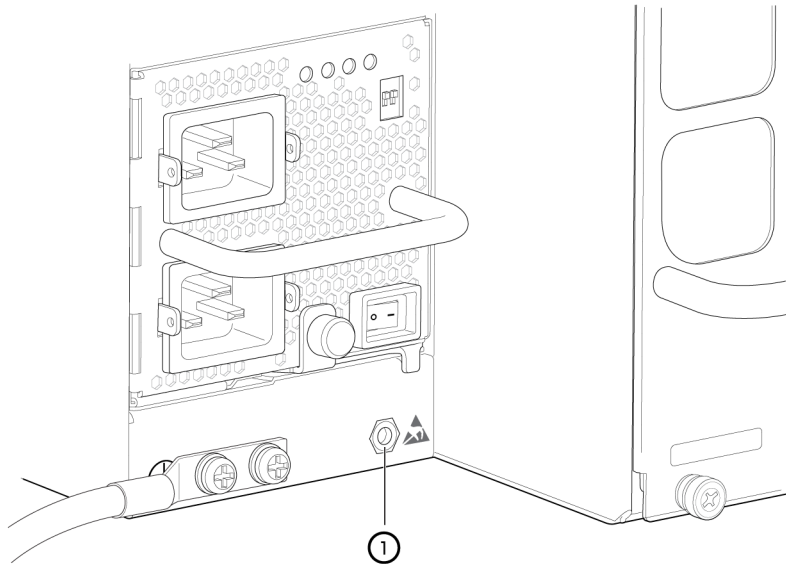
**Figure 110: ESD Point on QFX10008 Chassis Rear**



1– ESD point



Figure 111: ESD Point on QFX10016 Chassis Rear



8050729

1– ESD point

2. Flip the **Enable** switch next to the appliance inlet on the power supply to the standby position.
3. Disconnect power from the switch by performing one of the two following tasks:
  - If the AC power source outlets have a power switch, set them to the OFF position.
  - If the AC power source outlets do not have a power switch, gently pull the plug end of the power cords connected to the power source outlets out of the outlets.
4. Remove the power cords from the AC appliance inlets on the AC power supply faceplate.
5. Turn the adjustment nut of the power cord retainers counterclockwise till you can see the power cord. Pull the power cord from the slot in the adjustment nuts.
6. Unscrew the captive screw counterclockwise by using your fingers or by using the Phillips (+) screwdriver, number 1. See [Figure 112 on page 247](#) and [Figure 113 on page 248](#).
7. Rotate the captive screw away from the faceplate of the power supply to release the latch.
8. Taking care not to touch the power supply output connections, pins, leads, or solder connections, place one hand under the power supply to support it. Grasp the power supply handle with your other hand and pull the power supply completely out of the chassis.



**CAUTION:** Do not bump the output connections. If the connection hits a solid object, it could damage the power supply.

9. If you are not replacing the power supply, install the cover over the slot by inserting your thumb and forefinger into the finger holes, squeezing and pulling the cover out of the slot.

**Figure 112: Removing a QFX10000-PWR-AC Power Supply from a QFX10008**

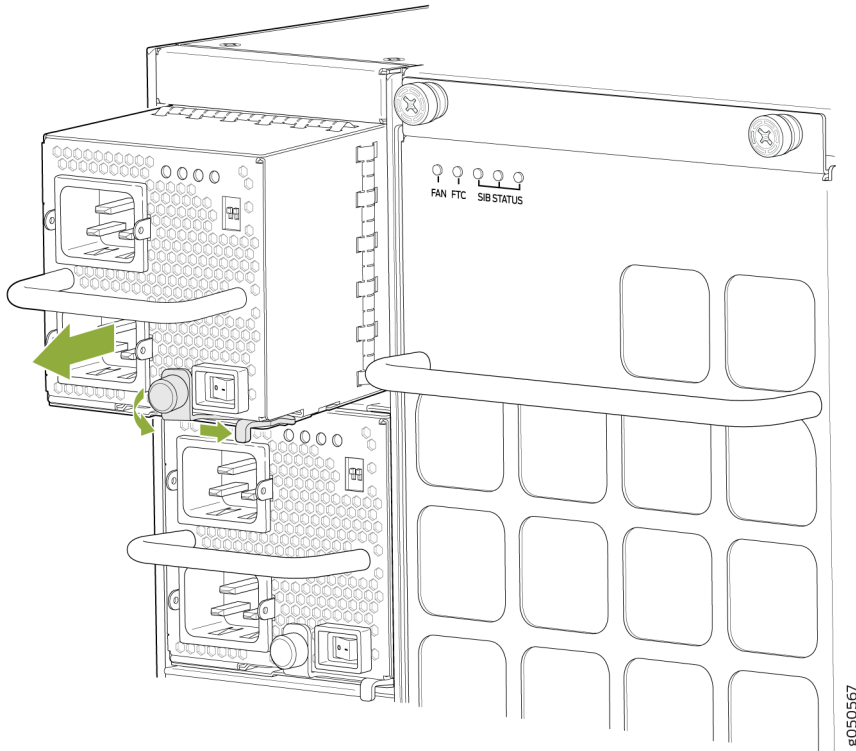
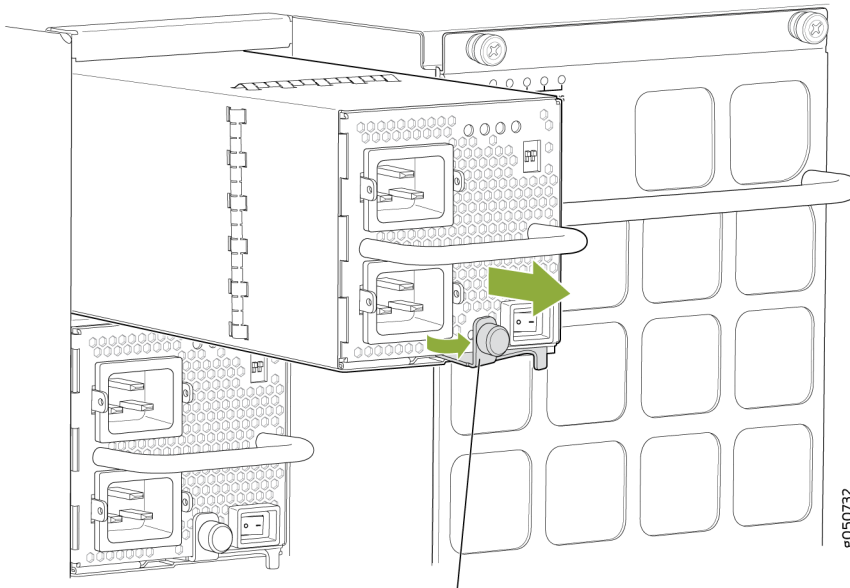


Figure 113: Removing a QFX10000-PWR-AC Power Supply from a QFX10016



Keep latch in open position during removal.

## How to Install a QFX10000-PWR-AC Power Supply

Before you install an QFX10000-PWR-AC power supply in the switch:

- Ensure you understand how to prevent ESD damage. See [Prevention of Electrostatic Discharge Damage](#).
- If the AC power source outlets have a power switch, set them to the off (O) position.

Ensure that you have the following parts and tools available to install a QFX10000-PWR-AC power supply:

- Electrostatic discharge (ESD) grounding strap
- Phillips (+) screwdriver, number 1
- Power cords appropriate for your geographical location. See "[QFX10000 Power Cables Specifications](#)" on page 52.
- Power cord retainer clips

The QFX10000-PWR-AC power supply is a hot-insertable and hot-removable field-replaceable unit (FRU). You can install up to 6 QFX10000-PWR-AC power supplies in a QFX10008 and 10 in a

QFX10016 switch chassis. All power supplies install in the rear of the chassis in the slots provided along the left side.



**CAUTION:** Do not mix AC and DC power supplies in the same chassis.

To install a QFX10000-PWR-AC power supply in a QFX10008 or QFX10016:

1. Attach the electrostatic discharge (ESD) grounding strap to your bare wrist, and connect the strap to the ESD point on the chassis. There is an ESD point located next to the protective earthing terminal and below **PSU 5** on the QFX10008 rear panel (see [Figure 114 on page 249](#)) or below **PSU\_9** on the QFX10016 (see [Figure 115 on page 250](#)).

**Figure 114: ESD Point on QFX10008 Chassis Rear**

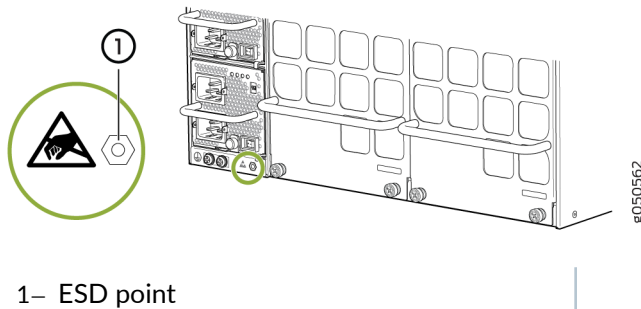
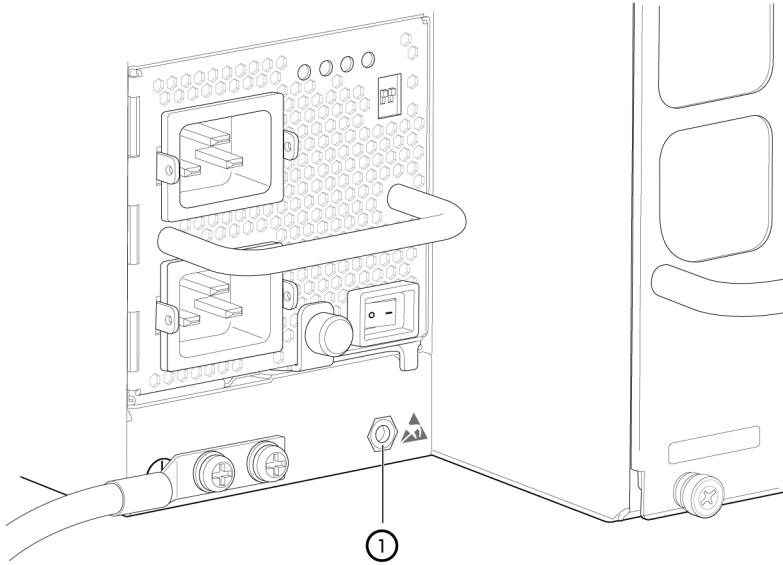


Figure 115: ESD Point on QFX10016 Chassis Rear



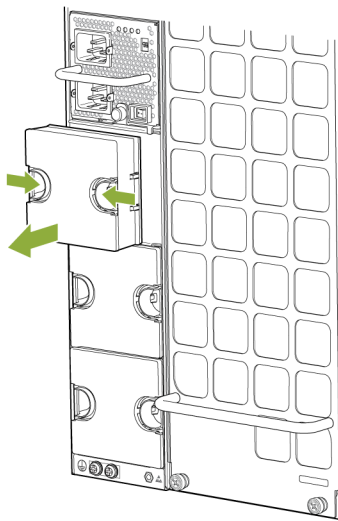
8050729

- 1- ESD point

---

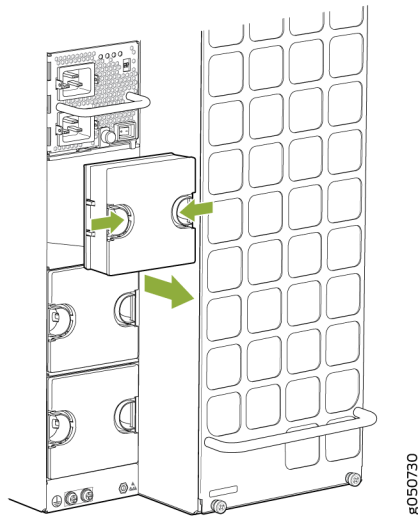
- 2. If the power supply slot has a cover panel, insert your thumb and forefinger into the finger holes, squeeze and pull the cover panel out of the slot. Save the cover panel for later use. See [Figure 116 on page 250](#) for removal on a QFX10008 and [Figure 117 on page 251](#) for the QFX10016.

Figure 116: Removing the PSU Cover Panel on a QFX10008



8050587

Figure 117: Removing the PSU Cover Panel on a QFX10016

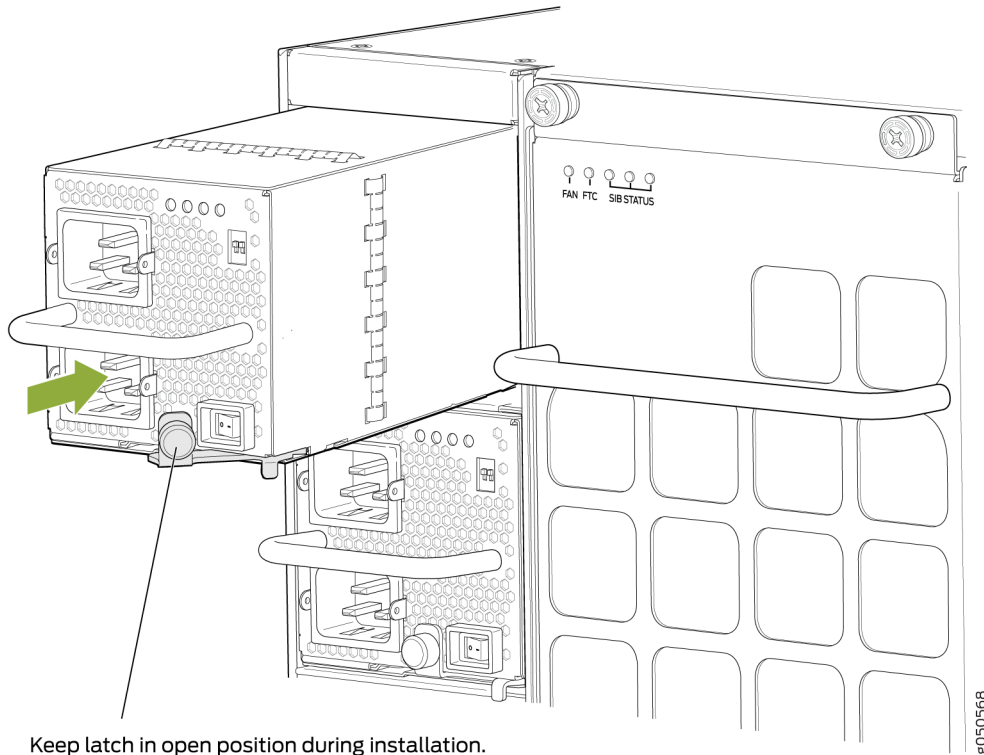


3. Taking care not to touch power supply connections, remove the power supply from its bag.
4. Peel back and remove the protective plastic wrap that covers all four sides of the power supply.
5. Ensure the power switch is set to the standby (O) position. This switch turns off the output voltage; it does not interrupt AC.
6. Unscrew the captive screw in the counterclockwise direction by using your fingers or by using the Phillips (+) screwdriver, number 1.
7. Rotate the captive screw away from the faceplate of the power supply to release the latch.

**NOTE:** You can install the power supplies in any slot labeled **PSU 0** through **PSU 5** (top to bottom) on a QFX10008, and **PSU 0** through **PSU 9** on a QFX10016.

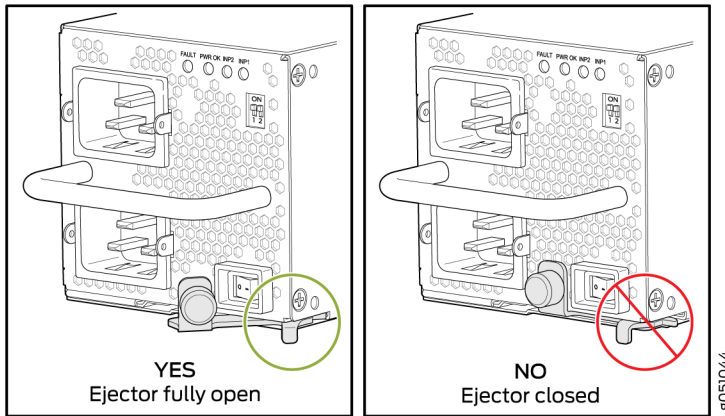
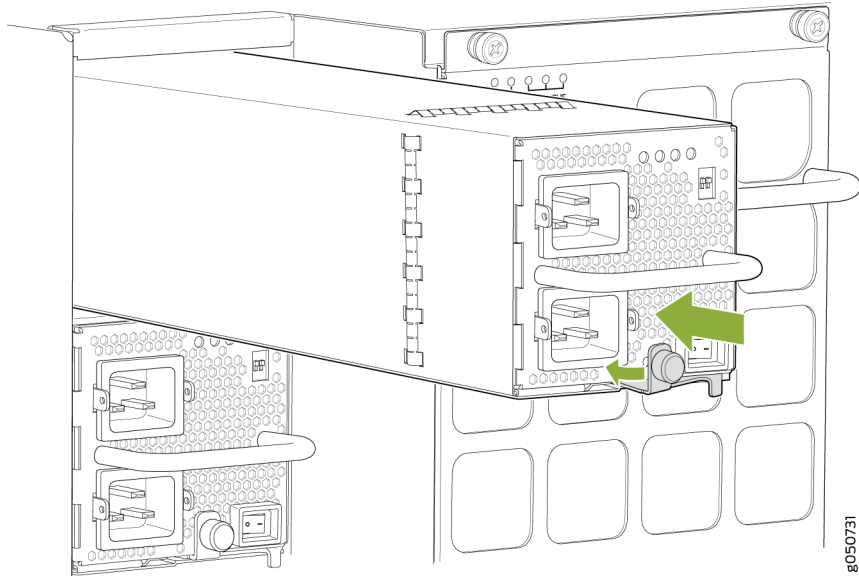
8. Using both hands, place the power supply in the power supply slot on the rear of the system.
9. Slide the power supply straight into the chassis until the power supply is fully seated in the slot. Ensure the power supply faceplate is flush with any adjacent power supply faceplates or power supply covers (see [Figure 118 on page 252](#) and [Figure 119 on page 253](#)).
10. Push the captive screw into the power supply faceplate. Ensure that the screw is seated inside the corresponding hole on the faceplate.
11. Tighten the captive screw by turning it clockwise by using your fingers or by using the Phillips (+) screwdriver, number 1. Do not overtighten—do not apply more than 7.3 lb-in (0.82 Nm) of torque to the screws. When the screw is completely tight, the latch locks into the switch chassis.

Figure 118: Installing a QFX10000-PWR-AC Power Supply in a QFX10008



**NOTE:** Ensure that the ejector is fully open to avoid scratching the chassis.

Figure 119: Installing a QFX10000-PWR-AC Power Supply in a QFX10016



12. Manually load balance the power supplies as you attach each power cable to a dedicated AC power source outlet. To load balance, route the power cables to alternate between power sources. The QFX10000-PWR-AC does not share power; all power comes into INP1 (lower receptacle) and only uses INP2 (top receptacle) at fail over. See [Figure 120 on page 254](#) for QFX10008 and [Figure 121 on page 254](#).



Figure 120: Proper Load Balancing for QFX10000-PWR-AC Power Cables on QFX10008

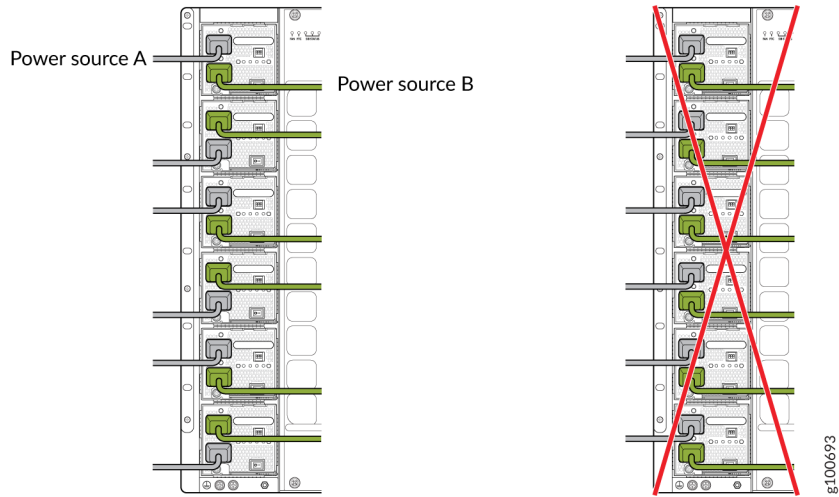
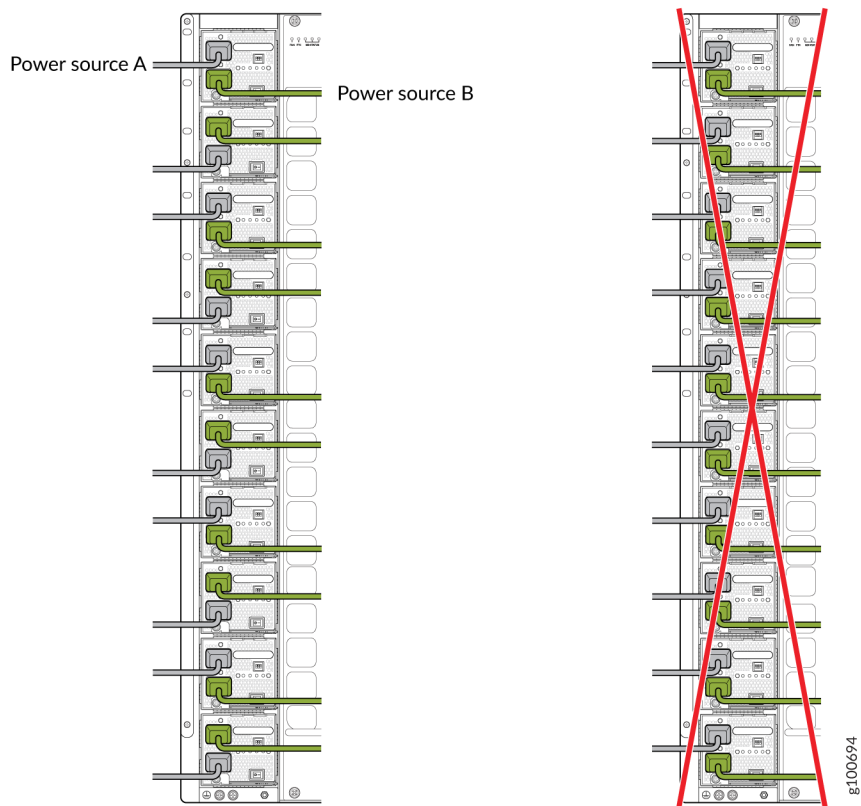


Figure 121: Proper Load Balancing for QFX10000-PWR-AC Power Cables on QFX10016





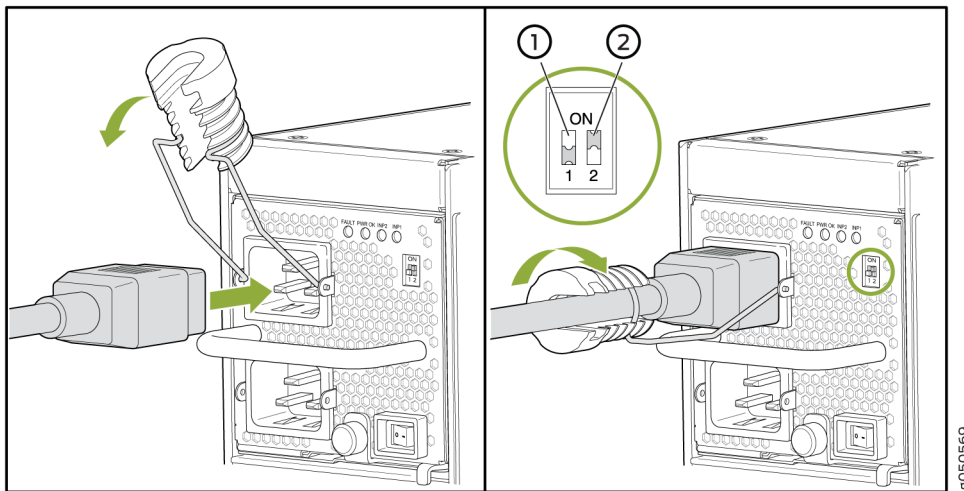
**WARNING:** Ensure that the power cords do not block access to router components or drape where people can trip on them. Always prevent cords and cables from being exposed to hot air exhaust by routing them away from the fan trays and power supplies at the rear of the chassis.

13. Squeeze the two sides of the power cord retainer clip and insert the ends of the clip into the holes in the bracket on each side of the AC appliance inlets on the AC power supply faceplate. See [Figure 122 on page 255](#).
14. Locate two power cords shipped with the switch; the cords have plugs appropriate for your geographical location.
15. Insert the power cord coupler into the power supply.

Each AC power supply has two independent 16 A rated AC inlets on the faceplate. Each inlet must be connected to a dedicated AC power feed to achieve 2n source redundancy. If redundancy is not a requirement, use the default input **INP1** for a single connection.

16. Fasten the cord retainer by lowering the clip over the cord and pushing the cord into the adjustment nut of the cord retainer. Rotate the nut until it is tight against the base of the cord. See [Figure 122 on page 255](#).

**Figure 122: Power Cord and Retainer Clip**



1– Enable switch for **INP1**

2– Enable switch for **INP2**



**WARNING:** Ensure that the power cords do not block access to switch components or drape where people can trip on them.

17. If the AC power source outlets have a power switch, set them to the on (I) position.
18. Move the enable switches for input 1 and input 2 to the **ON** position.
19. Verify that the **INP1** and **INP2** LEDs on the power supply faceplate are lit and are on steadily.
20. Press the power switch to the on (I) position.

## SEE ALSO

[QFX10008 Power Planning | 163](#)

[QFX10016 Power Planning](#)

## How to Remove a JNP10K-PWR-AC2 Power Supply

Before you remove an JNP10K-PWR-AC2 power supply from the chassis:

- Ensure you understand how to prevent ESD damage. See [Prevention of Electrostatic Discharge Damage](#).

Ensure that you have the following parts and tools available to remove a JNP10K-PWR-AC2 power supply from a QFX10000 switch:

- Heat protective gloves able to withstand temperatures in the range of 158°F (70°C) to 176°F (80°C)
- Electrostatic discharge (ESD) grounding strap
- Phillips (+) screwdriver, number 1
- Replacement power supply or a cover panel for the power supply slot

The JNP10K-PWR-AC2 power supply in a QFX10008 or a QFX10016 chassis is a hot-removable and hot-insertable field-replaceable unit (FRU). You remove all power supplies from the rear of the chassis.



**WARNING:** Protect yourself from severe burns by wearing heat-protective gloves when removing a working QFX10000-PWR-AC2 power supply from the chassis. These power supplies can reach in the range of 158°F (70°C) to 176°F (80°C).



**CAUTION:** Before you remove a power supply, ensure that you have power supplies sufficient to power the switch left in the chassis. See "[Power Requirements for QFX10000 Components](#)" on page 163.

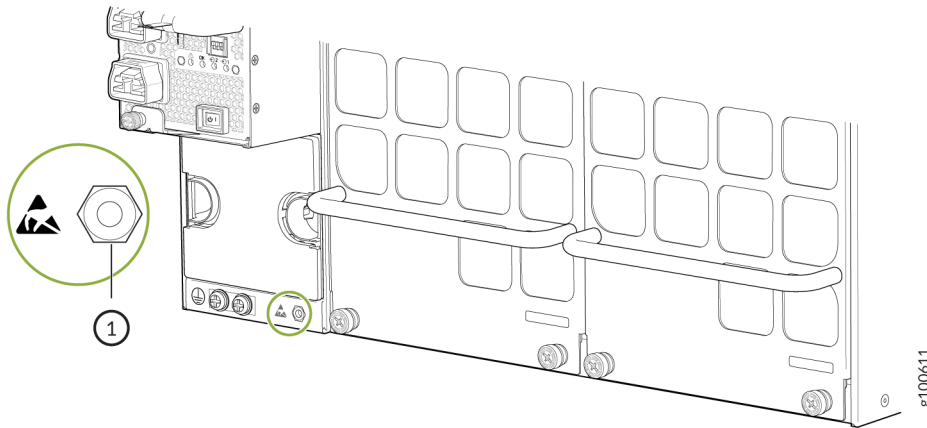


**CAUTION:** Do not leave the power supply slot empty for a long time while the switch is operational. Either replace the power supply promptly or install a cover panel over the empty slot.

To remove a JNP10K-PWR-AC2 power supply from a QFX10000 switch:

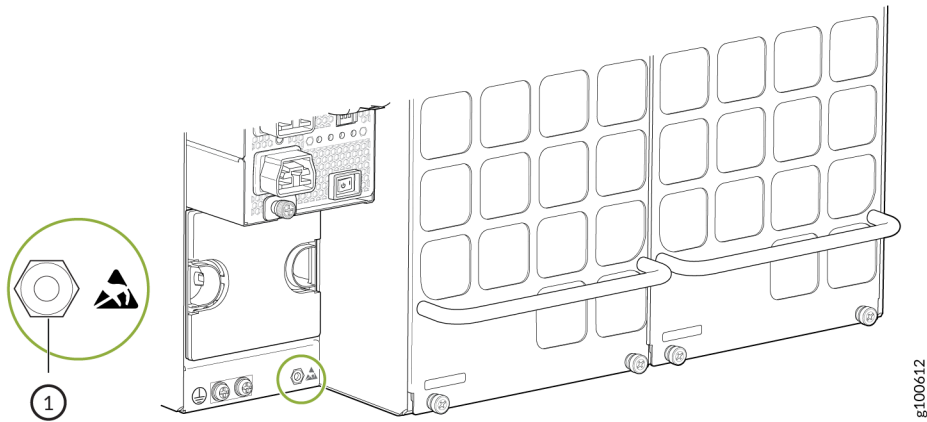
1. Attach the electrostatic discharge (ESD) grounding strap to your bare wrist, and connect the strap to the ESD point on the chassis. There is an ESD point located next to the protective earthing terminal and below **PSU 5** on the QFX10008 rear panel (see [Figure 123 on page 257](#)) and below **PSU\_9** on the QFX10016 (see [Figure 124 on page 258](#)).

**Figure 123: ESD Point on QFX10008 Chassis Rear**



1- ESD point

Figure 124: ESD Point on QFX10016 Chassis Rear



1– ESD point

2. Flip the power | switch next to the appliance inlet on the power supply to the standby position.
3. If the AC or DC power source outlets have a power switch, set them to the OFF position.
4. Disconnect the Anderson connectors from each input on the JNP10K-PWR-AC2 power supply faceplate.
5. Unscrew the captive screw counterclockwise by using your fingers or by using the Phillips (+) screwdriver, number 1. See [Figure 125 on page 259](#) and [Figure 126 on page 259](#).

Figure 125: Removing a JNP10K-PWR-AC2 from a QFX10008 Chassis

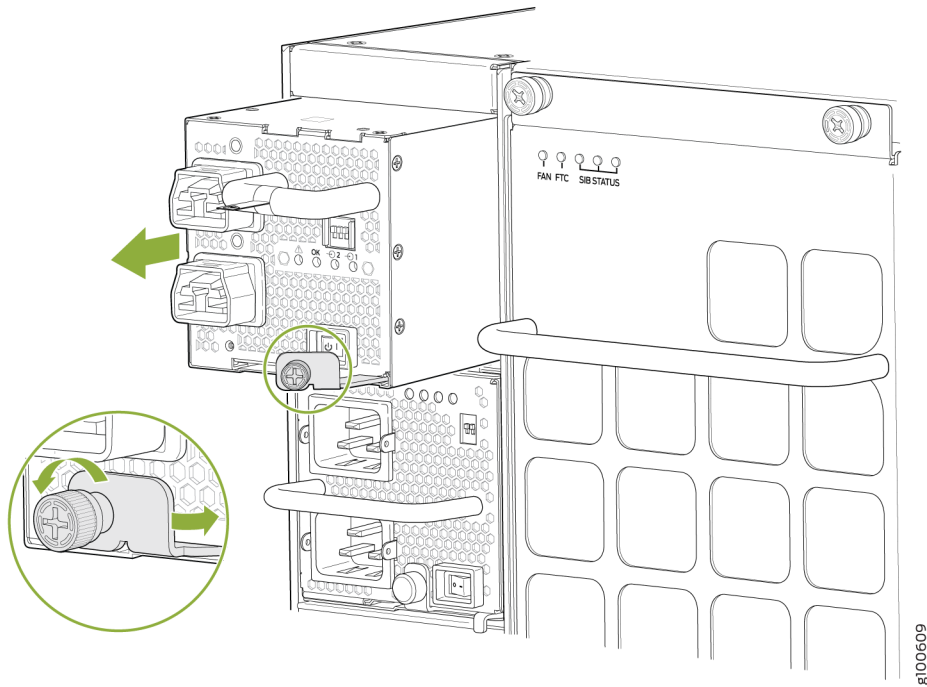
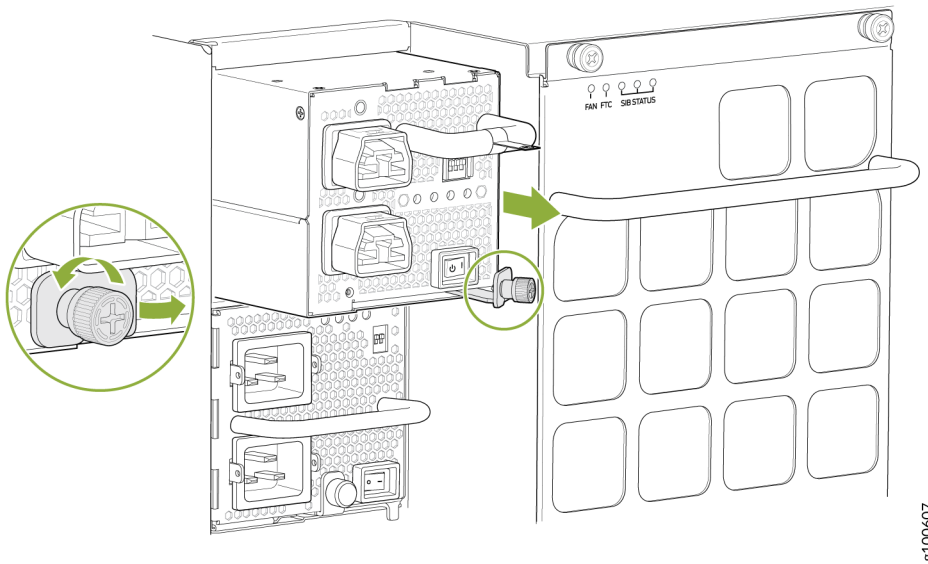


Figure 126: Removing a JNP10K-PWR-AC2 from a QFX10016 Chassis



6. Rotate the captive screw away from the faceplate of the power supply to release the latch.
7. Put on your heat protective gloves before removing the power supply from the chassis.

8. Taking care not to touch the power supply output connections, pins, leads, or solder connections, place one hand under the power supply to support it. Grasp the power supply handle with your other hand and pull the power supply completely out of the chassis.



**CAUTION:** Do not bump the output connections. If the connection hits a solid object, it could damage the power supply.

9. Place the JNP10K-PWR-AC2 on an antistatic surface to completely cool before placing the power supply in an antistatic bag for storage.
10. If you are not replacing the power supply, install the cover panel over the slot by inserting your thumb and forefinger into the finger holes, squeezing and pulling the cover out of the slot. Do not run the chassis without a power supply or cover panel in place.

## How to Install a JNP10K-PWR-AC2 Power Supply

The JNP10K-PWR-AC2 power supply in a QFX10008 or a QFX10016 chassis is a hot-insertable and hot-removable field-replaceable unit (FRU). You can install up to 6 JNP10K-PWR-AC2 power supplies in a QFX10008 and 10 in a QFX10016 switch chassis. All power supplies install in the rear of the chassis in the slots provided along the left side.



**CAUTION:** Do not mix AC and DC power supplies in the same running chassis. You may have both QFX10000-PWR-AC and JNP10K-PWR-AC2 in the same chassis while swapping out one type of power supply for the other.



**WARNING:** Protect yourself from severe burns by wearing heat-protective gloves when removing a running JNP10K-PWR-AC2 power supply from the chassis. The power supply can reach in the range of 158°F (70°C) to 176°F (80°C).

Before you install a JNP10K-PWR-AC2 power supply in the chassis:

Ensure that you have followed all safety warnings and cautions:

- Ensure you understand how to prevent ESD damage. See [Prevention of Electrostatic Discharge Damage](#).
- If the AC or DC power source outlets have a power switch, set them to the off (O) position.

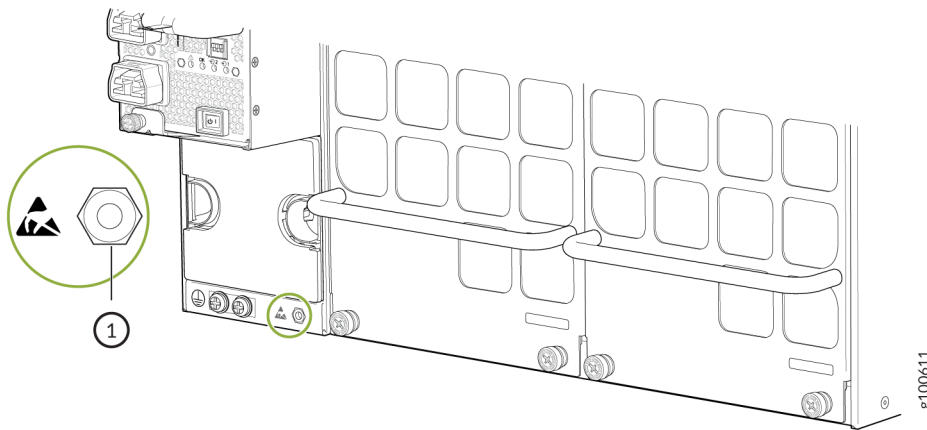
Ensure that you have the following parts and tools available to install an JNP10K-PWR-AC2 power supply:

- Electrostatic discharge (ESD) grounding strap
- Phillips (+) screwdriver, number 1
- Power cables appropriate for your geographical location (for low voltage installations) or input amperage (for high voltage installations). See "[QFX10000 Power Cables Specifications](#)" on page 52. HVAC and HVDC connectors and lugs must be installed by a qualified electrician before installation.

To install a JNP10K-PWR-AC2 power supply in a QFX10008 or a QFX10016:

1. Attach the electrostatic discharge (ESD) grounding strap to your bare wrist, and connect the strap to the ESD point on the chassis. There is an ESD point located next to the protective earthing terminal and below **PSU5** on the QFX10008 rear panel (see [Figure 127 on page 261](#)) or below **PSU9** on the QFX10016 (see [Figure 128 on page 262](#)).

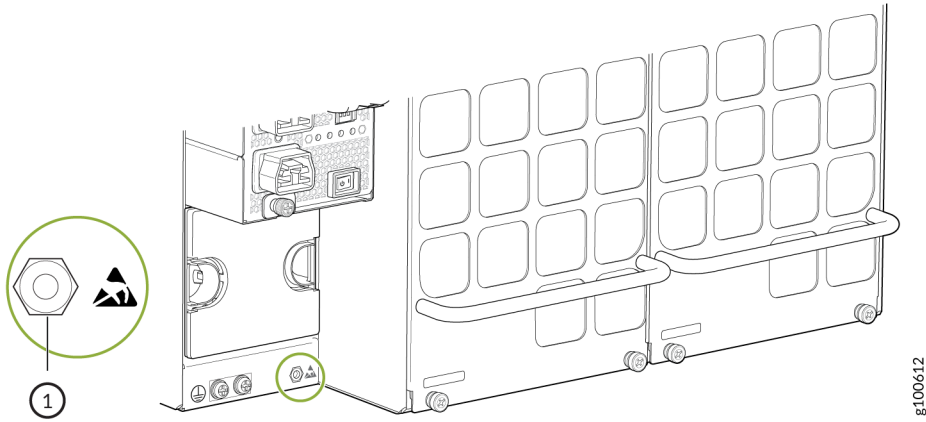
**Figure 127: ESD Point on the QFX10008 Chassis Rear**



1– ESD point



Figure 128: ESD Point on QFX10016 Chassis Rear



1- ESD point

2. If the power supply slot has a cover panel on it, insert your thumb and forefinger into the finger holes, squeeze, and pull the cover out of the slot. Save the cover panel for later use. See [Figure 129 on page 262](#) for removal on a QFX10008 and [Figure 130 on page 263](#) for the QFX10016.

Figure 129: Removing the Power Supply Cover Panel on a QFX10008

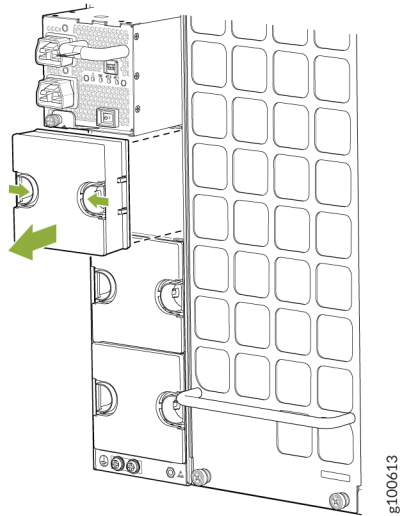
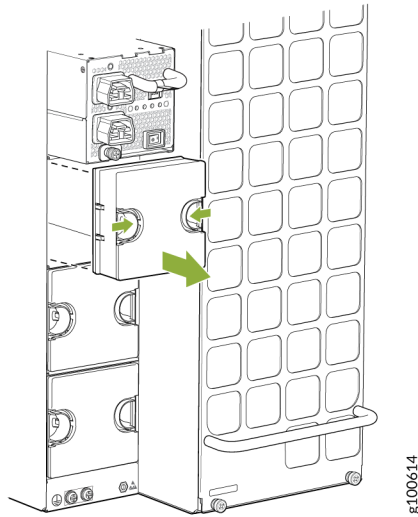


Figure 130: Removing the Power Supply Cover Panel on a QFX10016



3. Taking care not to touch power supply connections, remove the power supply from its bag.
4. Peel back and remove the protective plastic wrap that covers all four sides of the power supply.
5. Ensure the power switch is set to the standby (O) position. This switch turns off the output voltage; it does not interrupt input power.
6. Unscrew the captive screw in the counterclockwise direction by using your fingers or by using the Phillips (+) screwdriver, number 1.
7. Rotate the captive screw away from the faceplate of the power supply to release the latch.

**NOTE:** You can install the power supplies in any slot labeled **PSU 0** through **PSU 5** (top to bottom) on a QFX10008, and **PSU 0** through **PSU 9** on a QFX10016.

8. Using both hands, place the power supply in the power supply slot on the rear of the system. Slide the power supply straight into the chassis until the power supply is fully seated in the slot. Ensure the power supply faceplate is flush with any adjacent power supply faceplates or power supply cover panels (see [Figure 131 on page 264](#) and [Figure 132 on page 264](#)).
9. Push the captive screw into the power supply faceplate. Ensure that the screw is seated inside the corresponding hole on the faceplate.
10. Tighten the captive screw by turning it clockwise by using your fingers or by using the Phillips (+) screwdriver, number 1. When the screw is completely tight, the latch locks into the switch chassis.

Figure 131: Installing a JNP10K-PWR-AC2 in a QFX10008

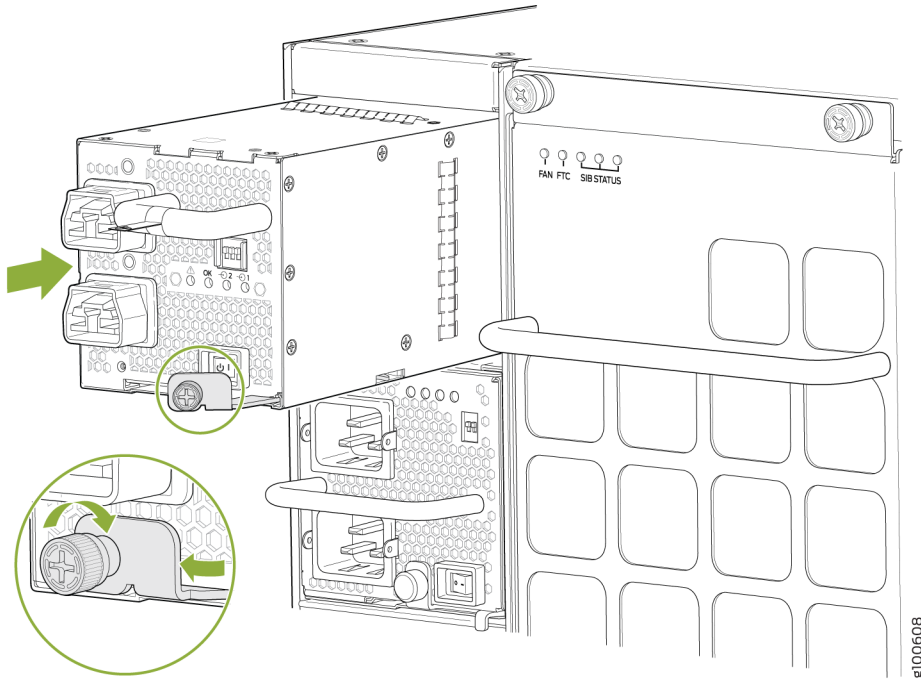
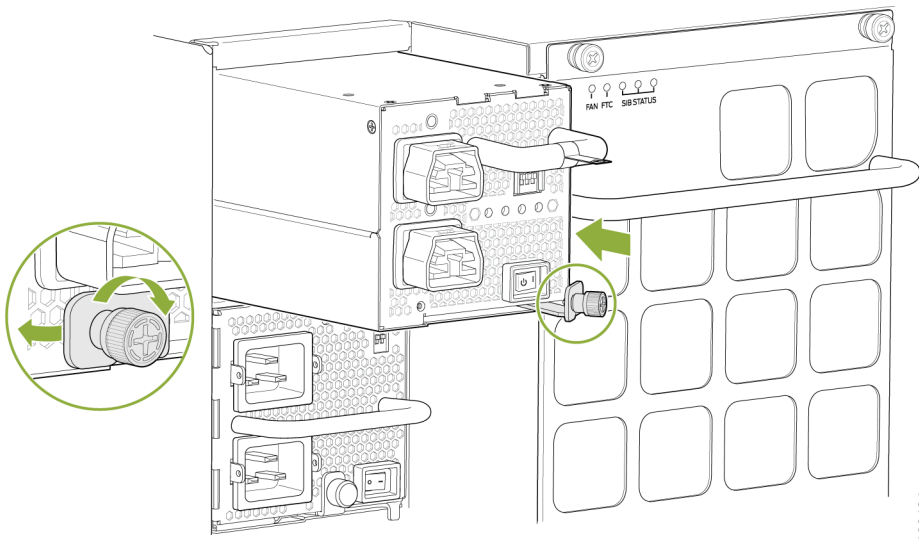


Figure 132: Installing a JNP10K-PWR-AC2 in a QFX10016



- 11. Attach each power cable to a dedicated power source (A and B). The JNP10K-PWR-AC2 only requires that each power supply be connected to a separate source. See [Figure 133 on page 265](#) for some possible cabling combinations for QFX10008 and [Figure 134 on page 266](#) for QFX10016.

**Figure 133: Proper Load Balancing for QFX10000-PWR-AC2 Power Cables on QFX10008**

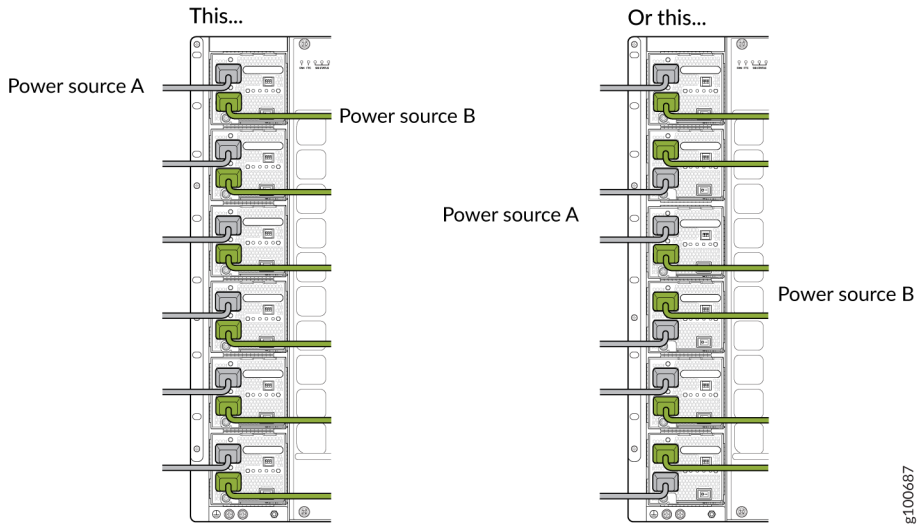
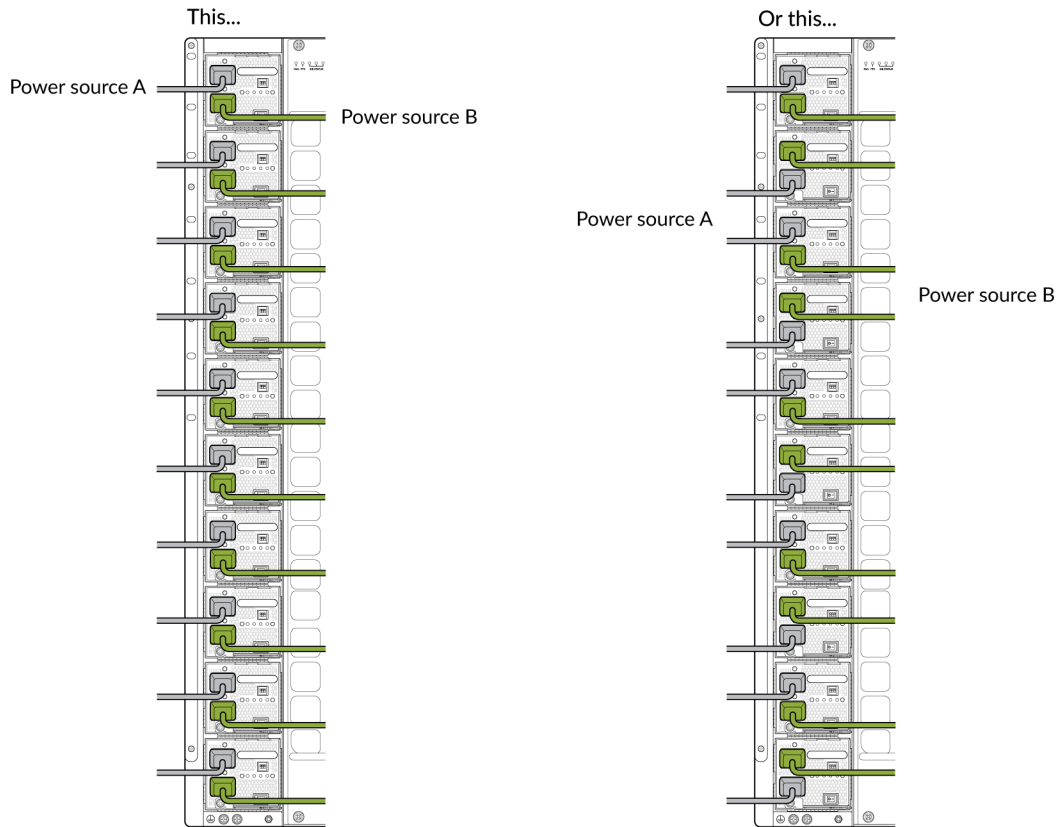


Figure 134: Proper Load Balancing for QFX10000-PWR-AC2 Power Cables on QFX100016



12. For each power cable, insert the end of the cable with the Anderson connector into the JNP10K-PWR-AC2 power supply module. The connector snaps and locks the cable into position.



**WARNING:** Ensure that the power cords do not block access to switch components or drape where people can trip on them.

13. If the AC or DC power source outlets have a power switch, set them to the on (I) position.
14. Set the three DIP switches to set the inputs and whether the power supply is running at 3000 W, 5000 W, or 5500 W. See [Table 80 on page 267](#).

Set both enable switches to the **on** position when using both source inputs. When not using source redundancy, set the unused source to the **O** (off) position. The LED turns red and indicates an error if a source input is not in use and the enable switch is | (on).

**Table 80: Setting the JNP10K-PWR-AC2 DIP Switches**

Switch	State	Field
1	On	IP0 is present
	Off	IP0 is not present
2	On	IP1 is present
	Off	IP1 is not present
3	On	Enabled for 30 A feed; 5500-W for a single feed, 5000-W for dual feeds
	Off	Enabled for 20 A feed; power supply capacity is 3000-W



**CAUTION:** It is important to connect both input feeds of the JNP10K-PWR-AC2 power supply to AC mains before loading the system with power.

15. Verify that the **INP1** and **INP2** LEDs on the power supply faceplate are lit and are on steadily.
16. Press the power switch to the on (I) position.

## How to Remove a QFX10000-PWR-DC Power Supply

Before you remove a DC power supply from the switch:

- Ensure you understand how to prevent ESD damage. See [Prevention of Electrostatic Discharge Damage](#).

Ensure that you have the following parts and tools available to remove a QFX10000-PWR-DC power supply:

- Electrostatic discharge (ESD) grounding strap
- Phillips (+) screwdriver, numbers 1 and 2

- 13/32 in. (10 mm) nut driver or socket wrench
- Replacement power supply or a cover for the power supply slot

The QFX10000-PWR-DC power supply in a QFX10008 and QFX10016 chassis is a hot-removable and hot-insertable field-replaceable unit (FRU). You remove DC power supplies from the rear of the chassis.



**CAUTION:** Before you remove a power supply, ensure that you have power supplies sufficient to power the switch left in the chassis. See "[Power Requirements for QFX10000 Components](#)" on page 163.



**WARNING:** Before performing DC power procedures, ensure that power is removed from the DC circuit. To ensure that all power is off, locate the circuit breaker on the panel board that services the DC circuit, switch the circuit breaker to the OFF position, and tape the switch handle of the circuit breaker in the OFF position.

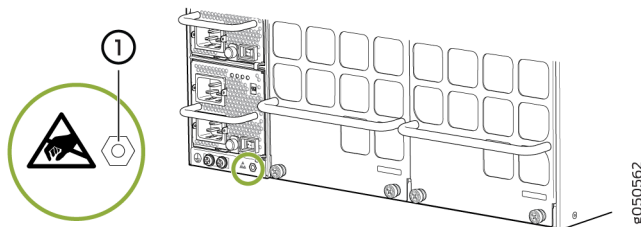


**CAUTION:** Do not leave the power supply slot empty for a long time while the switch is operational. Either replace the power supply promptly or install a cover over the empty slot.

To remove a QFX10000-PWR-DC power supply from a QFX10000 switch (see [Figure 137 on page 270](#)):

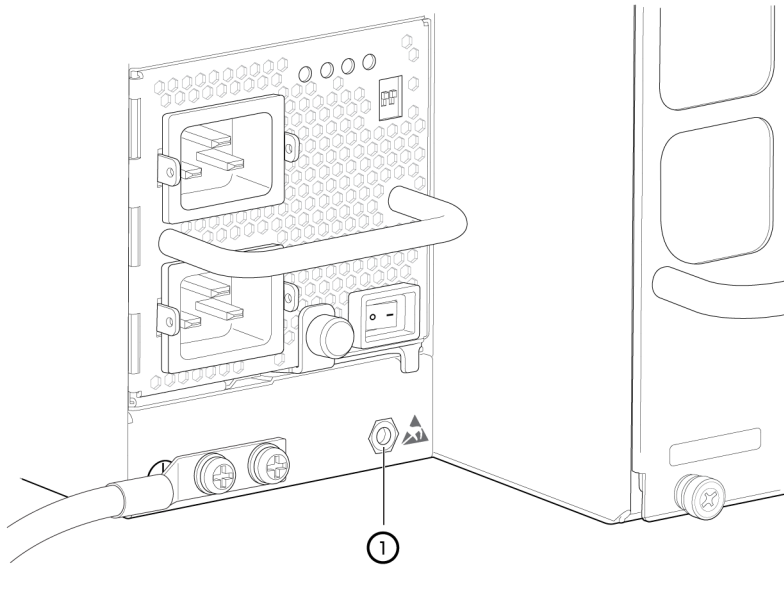
1. Attach the electrostatic discharge (ESD) grounding strap to your bare wrist, and connect the strap to the ESD point on the chassis. There is an ESD point located next to the protective earthing terminal and below **PSU 5** on the QFX10008 rear panel (see [Figure 135 on page 268](#)) and below **PSU\_9** on the QFX10016 (see [Figure 136 on page 269](#)).

**Figure 135: ESD Point on QFX10008 Chassis Rear**



1- ESD point

Figure 136: ESD Point on QFX10016 Chassis Rear



1– ESD point

2. Make sure that the voltage across the DC power source cables leads is 0 V and that there is no chance that the cables might become active during the removal process.
3. Ensure the black power supply output switch, to the right of the captive screw, is set to the standby position.
4. Unscrew the captive screw counterclockwise by using your fingers or by using the Phillips (+) screwdriver, number 1.
5. Rotate the captive screw away from the faceplate of the power supply to release the latch. See [Figure 137 on page 270](#) and [Figure 138 on page 271](#).
6. Taking care not to touch power supply components, pins, leads, or solder connections, place one hand under the power supply to support it. Grasp the power supply handle with your other hand and pull the power supply completely out of the chassis.



**CAUTION:** See the heat symbol





. The power supply surfaces are hot. Allow a few minutes for the power supply to cool by pulling the power supply halfway out of the chassis, or wear heat-resistant gloves while removing the power supply.

7. If you are not replacing the power supply, install the cover over the slot.
  - a. Insert your thumb and forefinger into the finger holes of the cover.
  - b. Squeeze and place the cover panel in the slot.
  - c. Release your fingers and the cover panel remains in the slot.
8. Unscrew the screw on the plastic cable cover that shield the input terminal studs counterclockwise by using the Phillips (+) screwdriver, number 2.
9. Unscrew the nuts counterclockwise using the 13/32 in. (10 mm) nut driver or socket wrench from the input terminal studs.
10. Remove the cable lugs from the input terminal studs.

**Figure 137: Removing a QFX10000-PWR-DC Power Supply from a QFX10008**

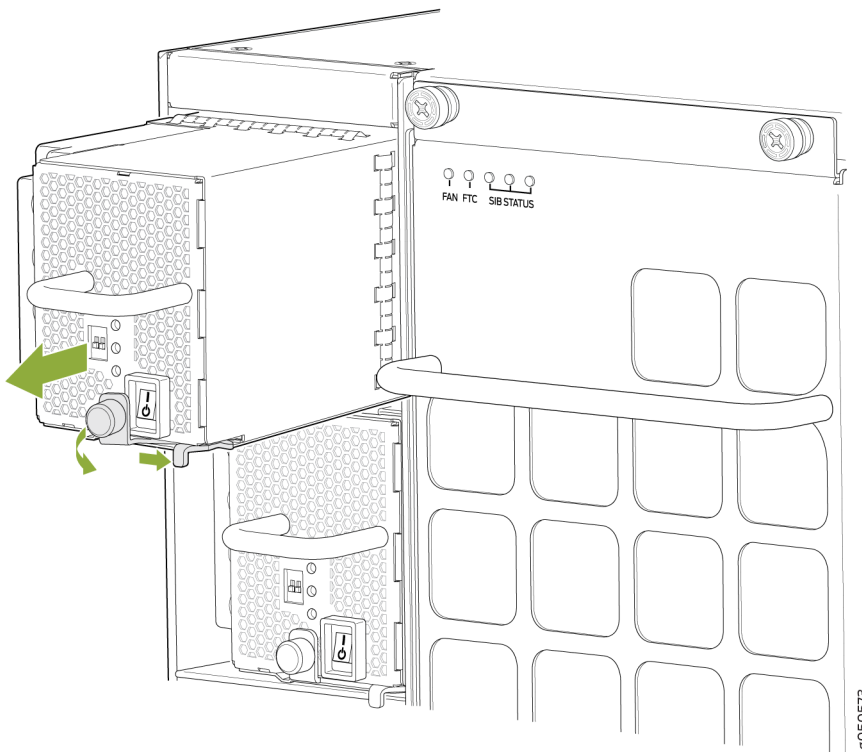
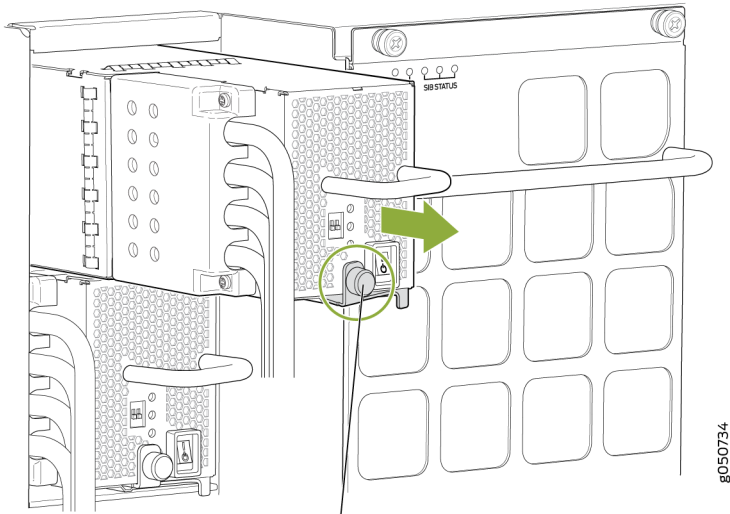
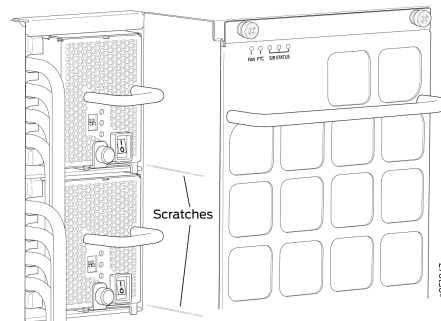
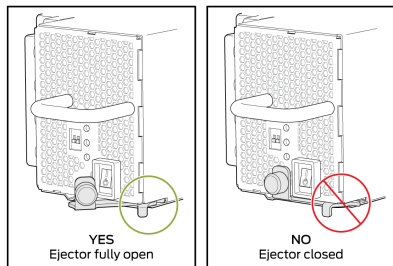


Figure 138: Removing a QFX10000-PWR-DC Power Supply from a QFX10016



Keep latch in open position during removal.

**NOTE:** Ensure that the ejector is fully open to avoid scratching the chassis.



## How to Install a QFX10000-PWR-DC Power Supply

Before you install a QFX10000-PWR-DC power supply in the chassis, ensure that you have followed all safety warnings and cautions:



**WARNING:** Before performing DC power procedures, ensure that power is removed from the DC circuit. To ensure that all power is off, locate the circuit breaker on the panel board that services the DC circuit, switch the circuit breaker to the OFF position, and tape the switch handle of the circuit breaker in the OFF position.



**CAUTION:** Before you connect power to the switch, a licensed electrician must attach a cable lug to the grounding and power cables that you supply. A cable with an incorrectly attached lug can damage the switch (for example, by causing a short circuit).



**CAUTION:** Do not mix AC and DC power supplies in the same chassis.



**CAUTION:** To meet safety and electromagnetic interference (EMI) requirements and to ensure proper operation, you must connect QFX10008 switches to earth ground before you connect them to power. For installations that require a separate grounding conductor to the chassis, use the protective earthing terminal on the switch chassis to connect to earth ground. For instructions on connecting a QFX10000 switch to ground using a separate grounding conductor, see "[Connect the QFX10008 or QFX10016 to Earth Ground](#)" on page 213.

**NOTE:** The battery returns of the QFX10000-PWR-DC power supply must be connected as an isolated DC return (DC-I).

- Ensure you understand how to prevent ESD damage. See [Prevention of Electrostatic Discharge Damage](#).
- Ensure that you have the following parts and tools available to install a QFX10000-PWR-DC power supply:
  - Electrostatic discharge (ESD) grounding strap
  - DC power source cables (not provided) with the cable lugs (provided) attached

The provided terminal lugs in a QFX10000 are sized for either 4 AWG (21.1 mm<sup>2</sup>) or 6 AWG (13.3 mm<sup>2</sup>) power source cables. When running all QFX10000-PWR-DC power supply modules in the chassis, the DC power source cables that you provide must be 6 AWG (13.3 mm<sup>2</sup>) stranded wire. We recommend that you install heat-shrink tubing insulation around the crimped section of the power cables and lugs.

**NOTE:** If you upgrade the QFX10000-PWR-DC to a JNP10K-PWR-DC2 and set the input mode to high (80-A), you must use 4 AWG (21.1 mm<sup>2</sup>) stranded wire.

**NOTE:** See the heat symbol



. Wear heat-resistant gloves while accessing the fan tray and power supply.

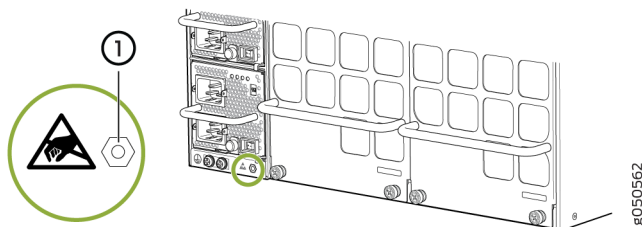
- 13/32 in. (10 mm) nut driver or socket wrench
- Phillips (+) screwdrivers, numbers 1 and 2
- Multimeter

The QFX10000-PWR-DC power supply in QFX10008 and QFX10016 chassis is a hot-removable and hot-insertable field-replaceable unit (FRU). You can install up to 6 QFX10000-PWR-DC power supplies in a QFX10008 switch chassis and 10 in a QFX10016 switch chassis. All DC power supplies install in the rear of the chassis in the slots along the left side of the chassis.

To install a QFX10000-PWR-DC power supply in a QFX10000:

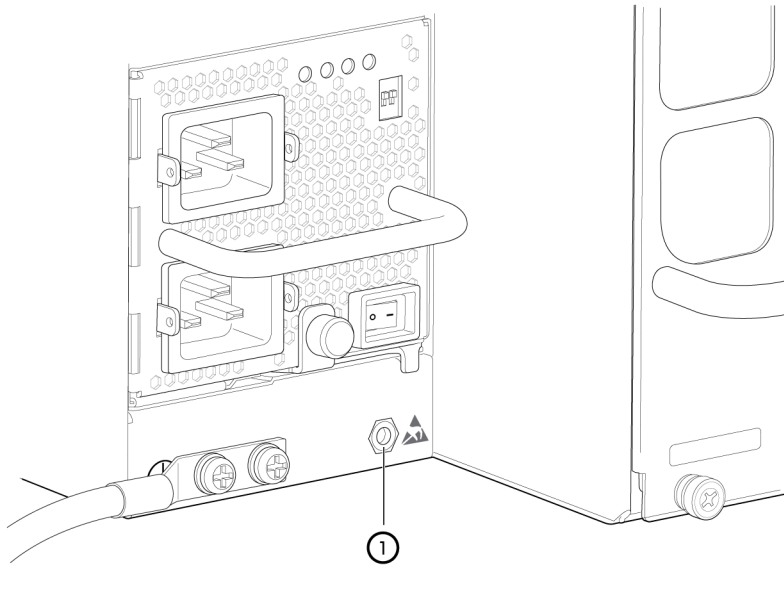
1. Attach the electrostatic discharge (ESD) grounding strap to your bare wrist, and connect the strap to the ESD point on the chassis. There is an ESD point located next to the protective earthing terminal and below **PSU 5** on the QFX10008 rear panel (see [Figure 139 on page 273](#)) and below **PSU\_9** on the QFX10016 rear panel (see [Figure 140 on page 274](#)).

**Figure 139: ESD Point on QFX10008 Chassis Rear**



1– ESD point

Figure 140: ESD Point on QFX10016 Chassis Rear



8050729

1– ESD point

2. Taking care not to touch power supply components, pins, leads, or solder connections, remove the power supply from its bag.



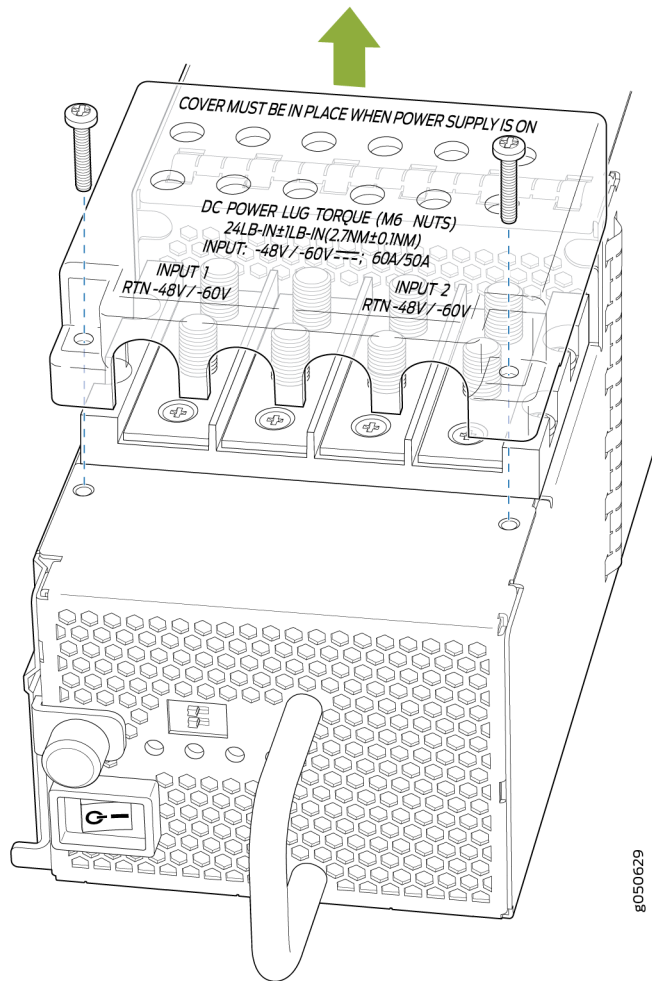
**CAUTION:** See the heat symbol



. The power supply surfaces are hot. Allow a few minutes for the power supply to cool by pulling the power supply halfway out of the chassis, or wear heat-resistant gloves while removing the power supply.

3. Peel back and remove the protective plastic wrap that covers all four sides of the power supply.
4. Ensure the power switch is set to the standby (O) position. This switch turns off the output voltage; it does not interrupt DC.
5. Remove the plastic cable cover from the DC power input terminals by using the Phillips (+) screwdriver, number 2, to loosen the screws (see [Figure 141 on page 275](#)).

Figure 141: Removing the Plastic Cable Cover on a QFX10000-PWR-DC Power Supply



6. Remove the nuts from each DC power input terminal, using the 13/32 in. (10 mm) nut driver or socket wrench to loosen the nuts.
7. Ensure that the power source circuit breaker is open so that the voltage across the DC power source cable leads is 0 V and that the cable leads do not become active while you are connecting DC power.
8. Install a power lug on each DC power cable. Ensure the lug meets the double hole standard lug terminal for 4 AWG wire. The lugs should be dual, 1/4 in. spaced 5/8 in. apart. The terminal must accommodate double hole standard lug terminal for 4 AWG or larger wire.
9. Verify that the DC power cables are correctly labeled before making connections to the power supply. In a typical power distribution scheme where the return is connected to chassis ground at the battery plant, you can use a multimeter to verify the resistance of the **-48V** and **RTN** DC cables to chassis ground:
  - The cable with very high resistance (indicating an open circuit) to chassis ground is negative (-) and will be installed on the **-48V** (input) DC power input terminal.

- The cable with very low resistance (indicating a closed circuit) to chassis ground is positive (+) and will be installed on the **RTN** (return) DC power input terminal.



**CAUTION:** You must ensure that power connections maintain the proper polarity. The power source cables might be labeled (+) and (-) to indicate their polarity. There is no standard color coding for DC power cables.

**10.** Install heat-shrink tubing insulation around the power cables.

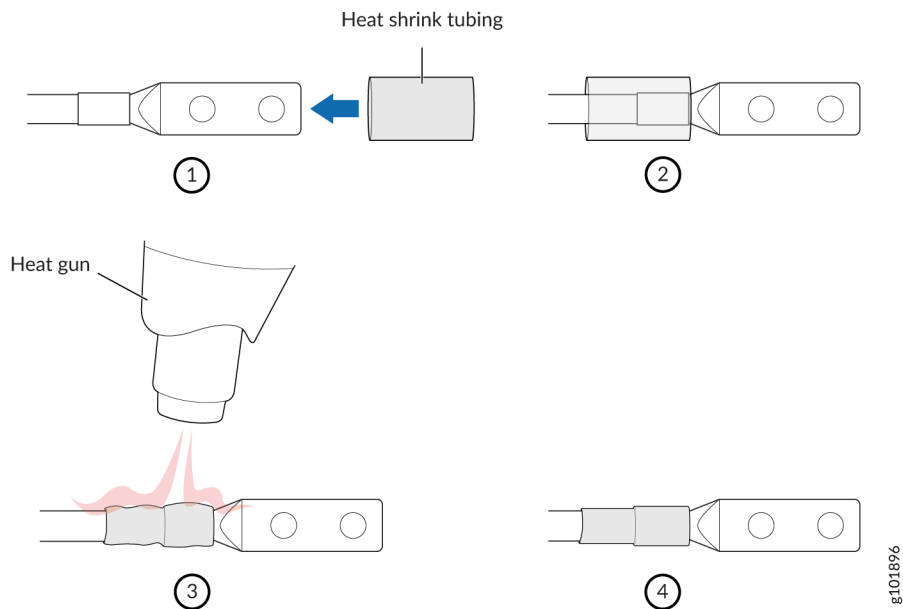
To install heat-shrink tubing:

- Slide the tubing over the portion of the cable where it is attached to the lug barrel. Ensure that tubing covers the end of the wire and the barrel of the lug attached to it.
- Shrink the tubing with a heat gun. Ensure that you heat all sides of the tubing evenly so that it shrinks around the cable tightly.

Figure 142 on page 276 shows the steps to install heat-shrink tubing.

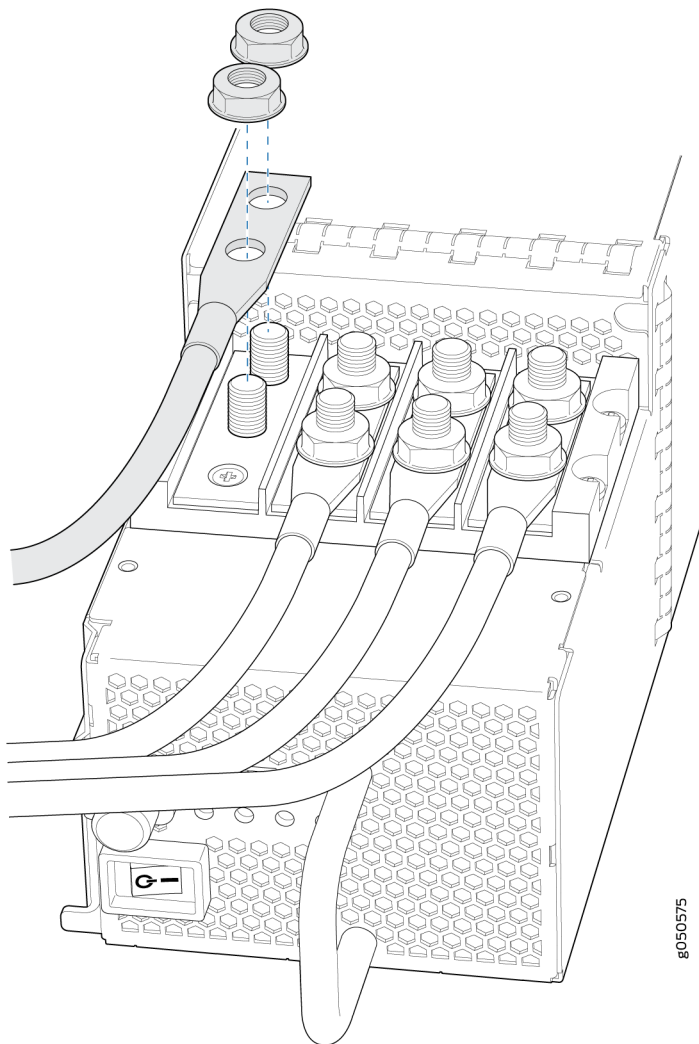
**NOTE:** Do not overheat the tubing.

**Figure 142: How to Install Heat-Shrink Tubing**



11. Install each power cable lug on the DC power input terminal, securing it with the nut (see [Figure 143 on page 277](#)). Apply between 23 in.-lb (2.6 Nm) and 25 in.-lb (2.8 Nm) of torque to each nut. (Use the 13/32 in. [10 mm] nut driver or socket wrench.)
  - a. Secure each positive (+) DC source power cable lug to the **RTN** (return) DC power input terminal.
  - b. Secure each negative (-) DC source power cable lug to the **-48V** (input) DC power input terminal.

**Figure 143: Connecting the QFX10000-PWR-DC Power Supply Cables to a QFX10000**



Each power supply has two independent sets of DC power input terminals (**INPUT 1: RTN -48V/-60V:** and **INPUT 2: : RTN -48V/-60V**). For feed redundancy, each power supply must be powered by dedicated power feeds derived from feed **INPUT 1** and feed **INPUT 2**. This configuration



provides the commonly deployed INPUT 1 / INPUT 2 feed redundancy for the switch. There is basic insulation between the inputs and the chassis ground. Also, there is basic insulation between RTN input feeds.

12. Install the plastic cable cover over each set of power cables by using the Phillips (+) screwdriver, number 2, to tighten the screw.
13. If the power supply slot on the chassis has a cover panel on it, insert your thumb and forefinger into the finger holes, squeeze, and pull the cover panel out of the slot. Save the cover panel for later use (see [Figure 144 on page 278](#) for QFX10008 installations and [Figure 145 on page 279](#) for QFX10016 installations).

**Figure 144: Removing the PSU Cover Panel on a QFX10008**

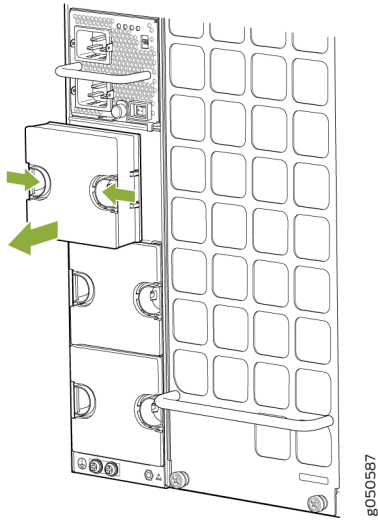
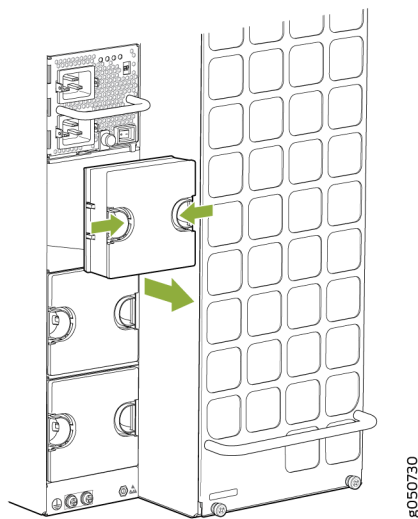


Figure 145: Removing the PSU Cover Panel on a QFX10016



14. Unscrew the captive screw in the counterclockwise direction by using your fingers or by using the Phillips (+) screwdriver, number 1.
15. Pull the captive screw away from the faceplate of the power supply to release the latch.

**NOTE:** You can install the power supplies in any slot labeled **PSU 0** through **PSU 5** (top to bottom) on a QFX10008 and **PSU 0** through **PSU 9** on a QFX10016.

16. Using both hands, place the power supply in the power supply slot on the rear of the switch..
17. Slide the power supply straight into the chassis until the power supply is fully seated in the slot. Ensure the power supply faceplate is flush with any adjacent power supply faceplates or power supply cover panels (see [Figure 146 on page 280](#) and [Figure 147 on page 280](#)).
18. Push the captive screw into the power supply faceplate. Ensure that the screw is seated inside the corresponding hole on the faceplate.
19. Tighten the captive screw by turning it clockwise by using your fingers or by using the Phillips (+) screwdriver, number 1. Do not overtighten—do not apply more than 7.3 lb-in. (0.82 Nm) of torque to the screws. When the screw is completely tight, the latch locks into the switch chassis.

Figure 146: Installing a QFX10000-PWR-DC Power Supply in a QFX10008

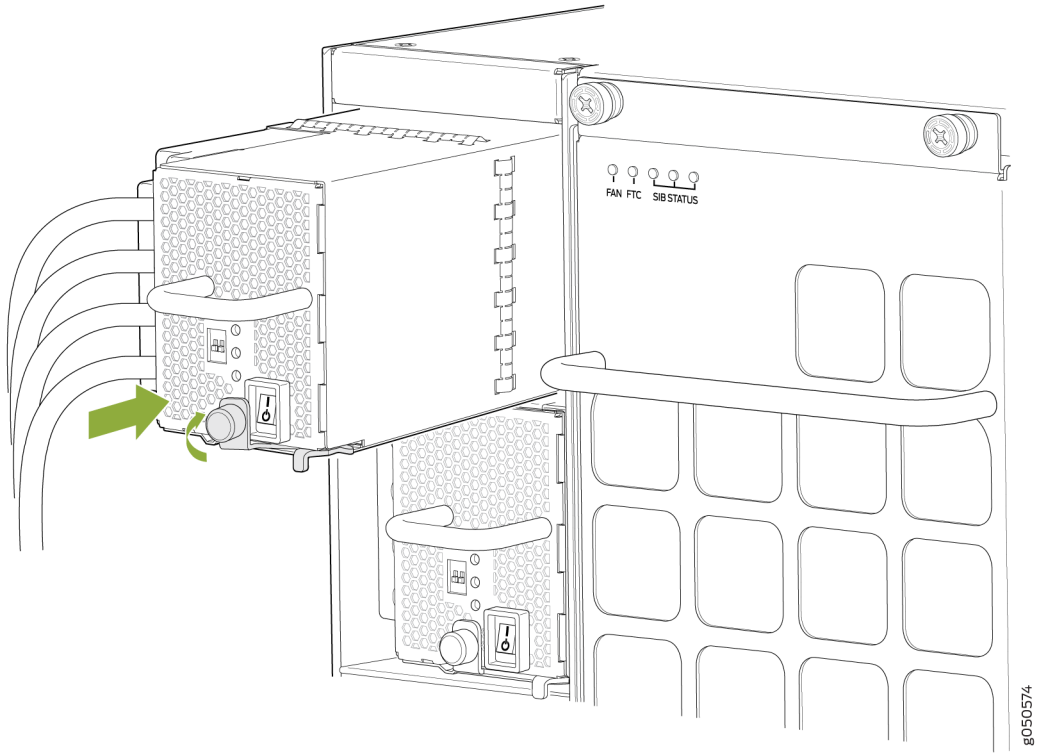
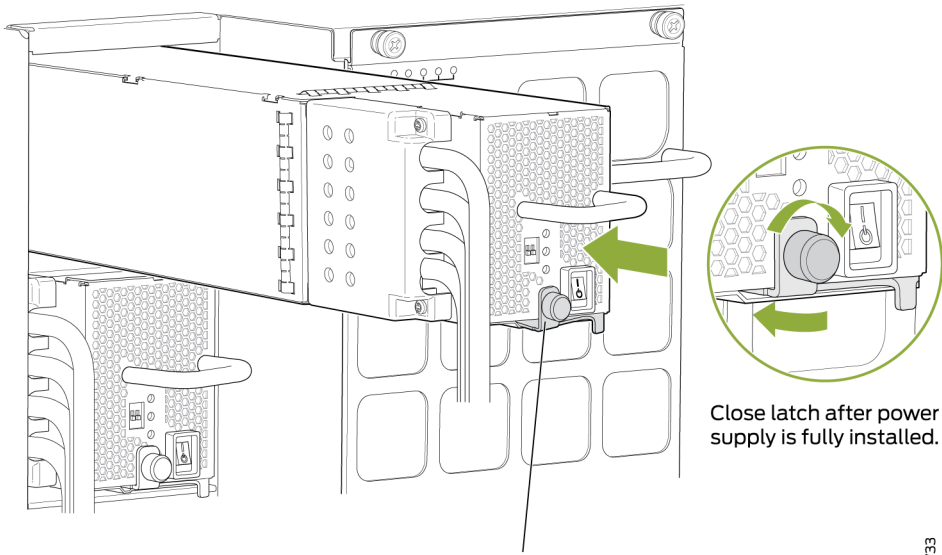


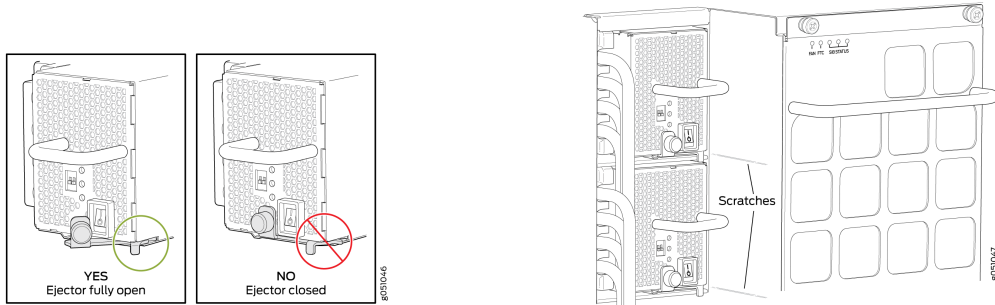
Figure 147: Installing a QFX10000-PWR-DC Power Supply in a QFX10016



Keep latch in open position during installation.

8050733

**NOTE:** Ensure that the ejector is fully open to avoid scratching the chassis.



- 20. Route INP1 cables to a power source and INP2 to another power source. The QFX10000-PWR-DC shares power, so if power dips on one input, the power supply is able to load balance internally. See [Figure 148 on page 281](#) and [Figure 149 on page 282](#).

**Figure 148: Proper Load Balancing for QFX10000-PWR-DC Power Cables on QFX10008**

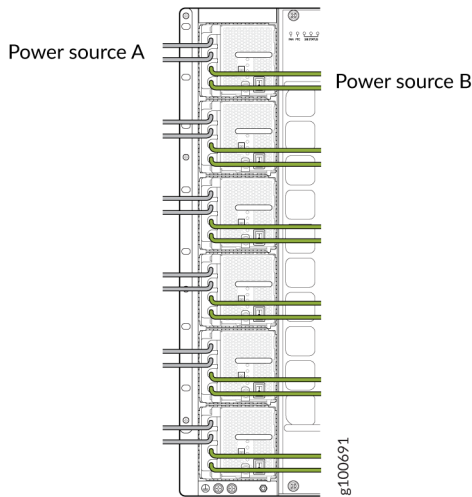
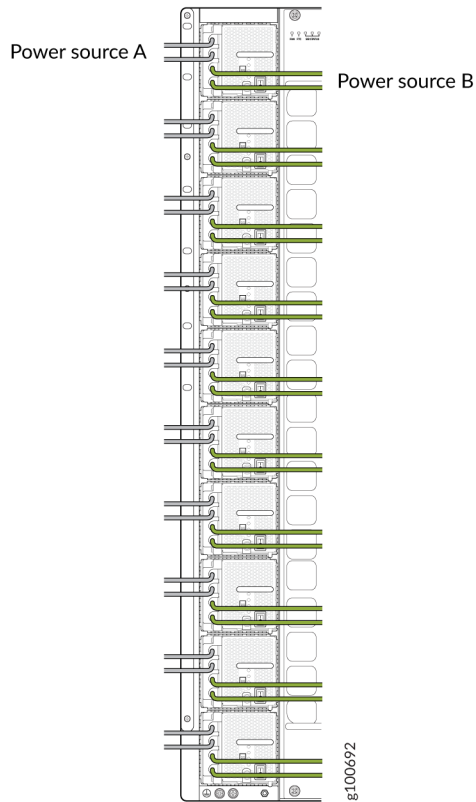


Figure 149: Proper Load Balancing for QFX10000-PWR-DC Power Cables on QFX100016

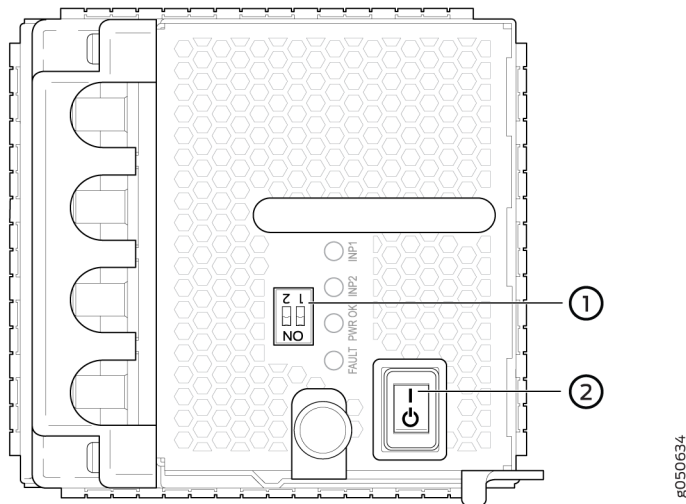


**WARNING:** Ensure that the power cables do not block access to router components or drape where people can trip on them. Always prevent cables from being exposed to hot air exhaust by routing them away from the fan trays and power supplies at the rear of the chassis.

21. Set the enable switches for input 1 and input 2 (see [Figure 150 on page 283](#)).

Set both enable switches to the | (on) position when using both source inputs. When not using source redundancy, set the unused source to the O (off) position. The LED turns red and indicates an error if a source input is not in use and the enable switch is | (on).

Figure 150: Setting the Enable Switches for the Power Source



1– Dip switches for enabling input sources

2– Power switch, on (I) and standby (o)

22. Verify that the input 1 and 2 LEDs on the power supply faceplate are lit and are on steadily.
23. Press the power switch to the on (I) position.

## How to Remove a JNP10K-PWR-DC2 Power Supply

Before you remove a DC power supply from the switch:

- Ensure you understand how to prevent ESD damage. See [Prevention of Electrostatic Discharge Damage](#).

Ensure that you have the following parts and tools available to remove a JNP10K-PWR-DC2 power supply:

- Heat protective gloves able to withstand temperatures in the range of 158°F (70°C) to 176°F (80°C)
- Electrostatic discharge (ESD) grounding strap
- Phillips (+) screwdriver, numbers 1 and 2
- 13/32 in. (10 mm) nut driver or socket wrench
- Replacement power supply or a cover panel for the power supply slot

The JNP10K-PWR-DC2 power supply in a QFX10000 chassis is a hot-removable and hot-insertable field-replaceable unit (FRU). You remove power supplies from the rear of the chassis.



**CAUTION:** A working JNP10K-PWR-DC2 power supply can reach temperatures in the range of 158°F (70°C) to 176°F (80°C); In order to avoid injury, do not touch a running power supply with your bare hands.



**CAUTION:** Before you remove a power supply, ensure that you have power supplies sufficient to power the switch left in the chassis. See "[QFX10008 Power Planning](#)" on [page 163](#), [QFX10016 Power Planning](#) and "[Power Requirements for QFX10000 Components](#)" on [page 163](#).

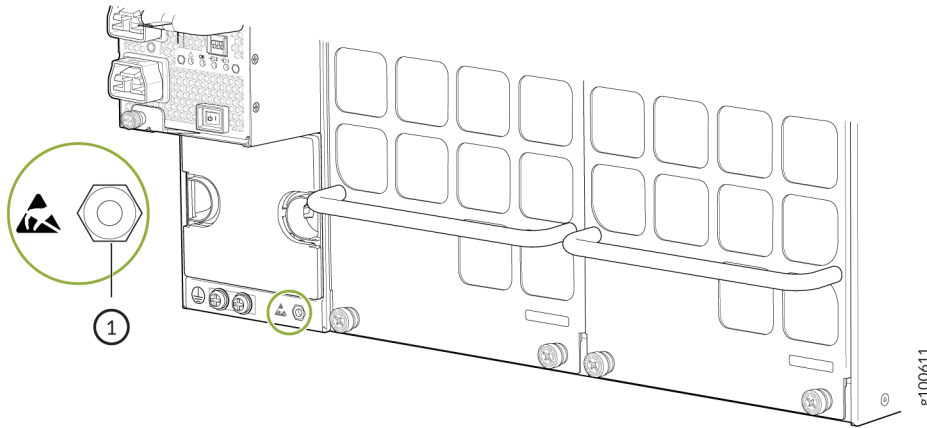


**CAUTION:** Do not leave the power supply slot empty for a long time while the switch is operational. Either replace the power supply promptly or install a cover panel over the empty slot.

To remove a JNP10K-PWR-DC2 power supply from a QFX10000 switch:

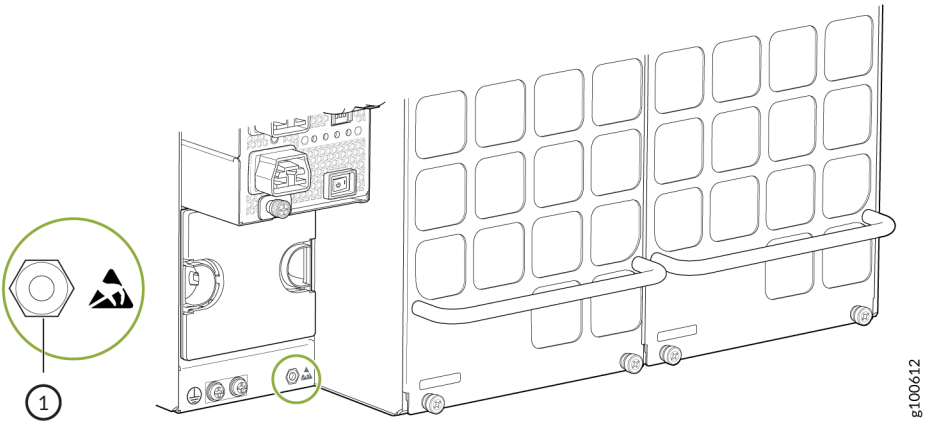
1. Attach the electrostatic discharge (ESD) grounding strap to your bare wrist, and connect the strap to the ESD point on the chassis. There is an ESD point located next to the protective earthing terminal and below **PSU 5** on the QFX10008 rear panel (see [Figure 151 on page 285](#) and below **PSU\_9** on the QFX10016 (see [Figure 152 on page 285](#)).

Figure 151: ESD Point on QFX10008 Chassis Rear



1– ESD point

Figure 152: ESD Point on QFX10016 Chassis Rear



1– ESD point

2. Make sure that the voltage across the DC power source cables leads is 0 V and that there is no chance that the cables might become active during the removal process.
3. Ensure the black power supply output switch, to the right of the captive screw, is set to the standby position.
4. Unscrew the captive screw counterclockwise by using your fingers or by using the Phillips (+) screwdriver, number 1.
5. Rotate the captive screw away from the faceplate of the power supply to release the latch. (See [Figure 153 on page 286](#) and [Figure 154 on page 286](#).)



Figure 153: Removing a JNP10K-PWR-DC2 Power Supply on QFX10008

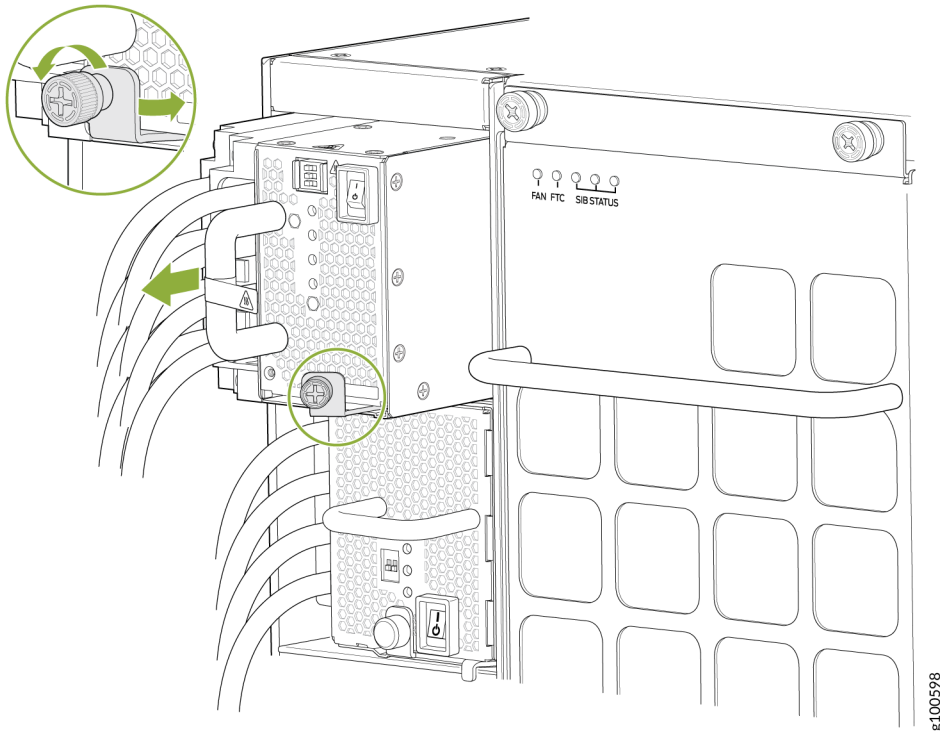
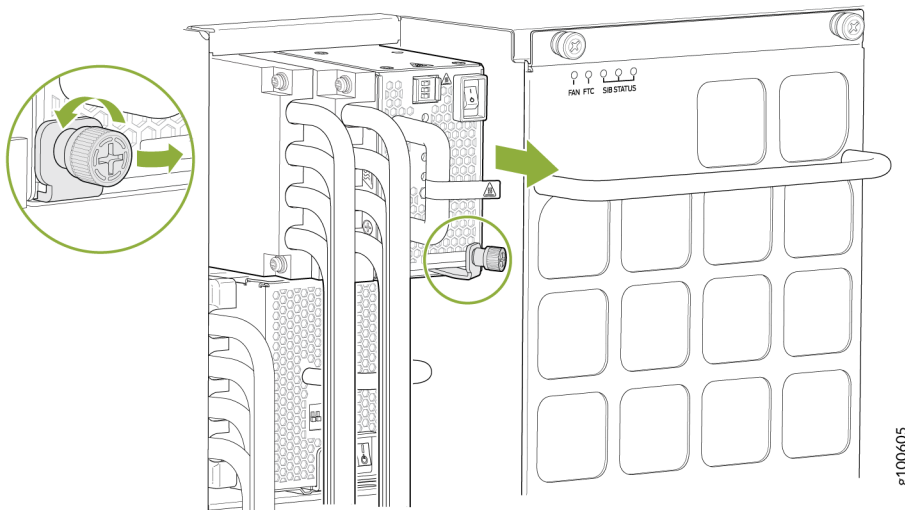


Figure 154: Removing a JNP10K-PWR-DC2 Power Supply on QFX10016



6. Put on the heat resistant gloves to protect your hands from the hot power supply.

7. Taking care not to touch power supply components, pins, leads, or solder connections, place one gloved hand under the power supply to support it. Grasp the power supply handle with your other hand and pull the power supply completely out of the chassis.
8. If you are not replacing the power supply, install the cover panel over the slot.
  - a. Insert your thumb and forefinger into the finger holes of the cover panel.
  - b. Squeeze and place the cover in the slot.
  - c. Release your fingers and the cover remains in the slot.
9. Unscrew the screw on the plastic cable cover that shield the input terminal studs counterclockwise by using the Phillips (+) screwdriver, number 2.
10. Unscrew the nuts counterclockwise using the 13/32 in. (10 mm) nut driver or socket wrench from the input terminal studs.
11. Remove the cable lugs from the input terminal studs.

## How to Install a JNP10K-PWR-DC2 Power Supply

Before you install an HVDC power supply in the chassis, ensure that you have followed all safety warnings and cautions:



**WARNING:** Before performing DC power procedures, ensure that power is removed from the DC circuit. To ensure that all power is off, locate the circuit breaker on the panel board that services the DC circuit, switch the circuit breaker to the OFF position, and tape the switch handle of the circuit breaker in the OFF position.



**WARNING:** Protect yourself from severe burns by wearing heat-protective gloves when removing a working HVDC power supply from the chassis. HVDC power supplies can reach in the range of 158°F (70°C) to 176°F (80°C).



**CAUTION:** Before you connect power to the switch, a licensed electrician must attach a cable lug to the grounding and power cables that you supply. A cable with an incorrectly attached lug can damage the switch (for example, by causing a short circuit).



**CAUTION:** Do not mix AC, DC, or HVDC power supplies in the same running chassis. You can mix DC and HVDC power supplies while swapping out one type for another during installation.



**CAUTION:** To meet safety and electromagnetic interference (EMI) requirements and to ensure proper operation, you must connect QFX10008 switches to earth ground before you connect them to power. For installations that require a separate grounding conductor to the chassis, use the protective earthing terminal on the switch chassis to connect to earth ground. For instructions on connecting a QFX10000 switch to ground using a separate grounding conductor, see "[Connect the QFX10008 or QFX10016 to Earth Ground](#)" on page 213.

**NOTE:** The battery returns of the JNP10K-PWR-DC2 power supply must be connected as an isolated DC return (DC-I).

- Ensure you understand how to prevent ESD damage. See [Prevention of Electrostatic Discharge Damage](#).
- Ensure that you have the following parts and tools available to install a DC power supply:
  - Electrostatic discharge (ESD) grounding strap
  - Use high current cable assembly, CBL-PWR2-BARE (not provided) with the cable lugs (provided) attached

The provided terminal lugs for the JNP10K-PWR-DC2 are Panduit LCD4-14A-L, or equivalent, and sized for 4 AWG (21.1 mm<sup>2</sup>) power source cables. We recommend that you install heat-shrink tubing insulation around the crimped section of the power cables and lugs.

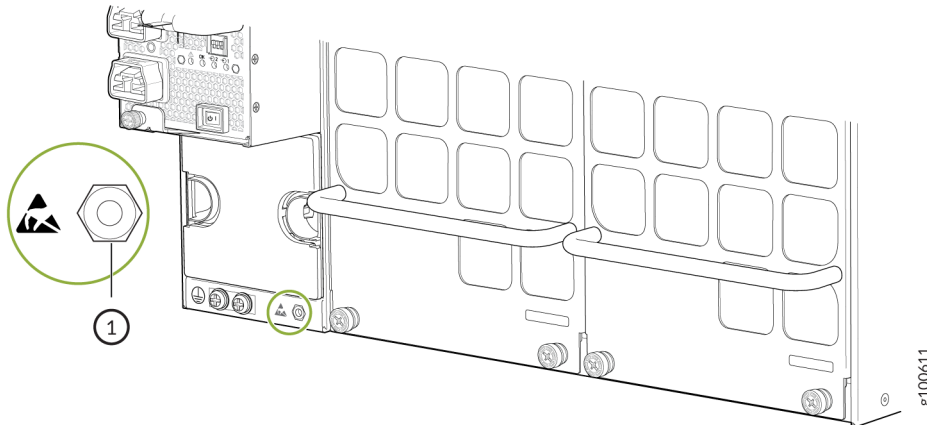
- 13/32 in. (10 mm) nut driver or socket wrench
- Phillips (+) screwdrivers, numbers 1 and 2
- Multimeter

The JNP10K-PWR-DC2 power supply in a QFX10000 chassis is a hot-removable and hot-insertable field-replaceable unit (FRU). You can install up to 6 power supplies in a QFX10008 switch chassis. All HVDC power supplies install in the rear of the chassis in the slots along the left side of the chassis.

To install a JNP10K-PWR-DC2 power supply in a QFX10008 or QFX10016 :

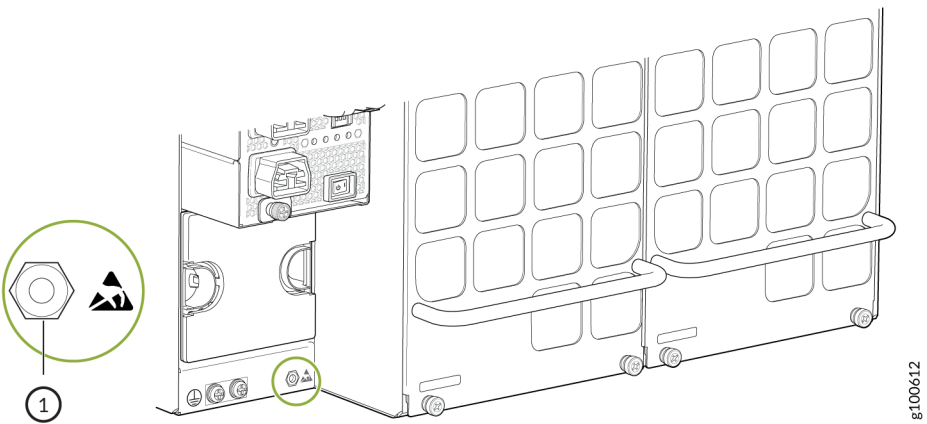
1. Attach the electrostatic discharge (ESD) grounding strap to your bare wrist, and connect the strap to the ESD point on the chassis. There is an ESD point located next to the protective earthing terminal and below **PSU 5** on the QFX10008 rear panel (see [Figure 155 on page 289](#)) and below **PSU\_9** on the QFX10016 (see [Figure 156 on page 289](#)).

**Figure 155: ESD Point on QFX10008 Chassis Rear**



1– ESD point

**Figure 156: ESD Point on QFX10016 Chassis Rear**

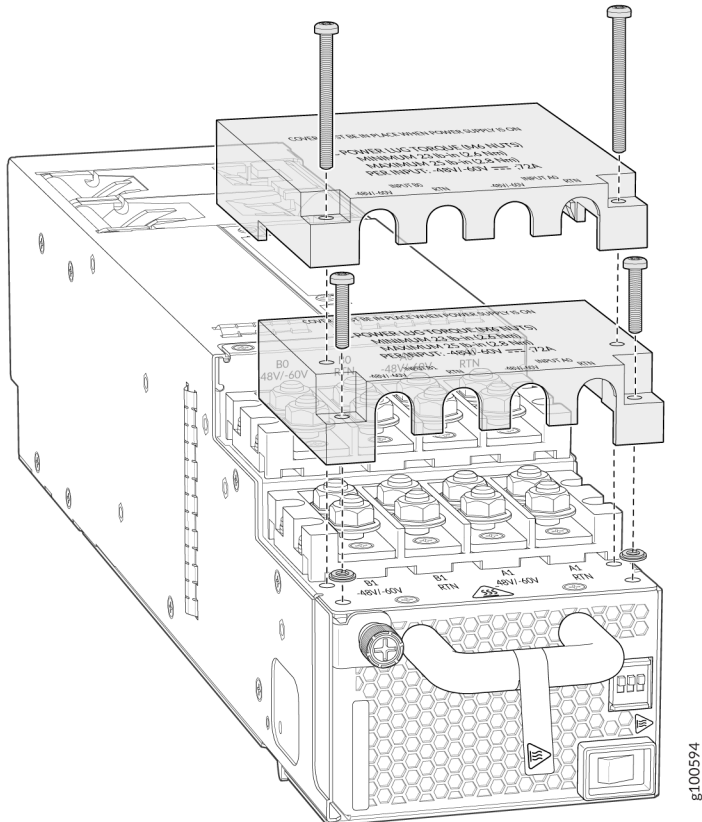


1– ESD point

2. Taking care not to touch power supply components, pins, leads, or solder connections, remove the power supply from its bag.
3. Peel back and remove the protective plastic wrap that covers all four sides of the power supply.

4. Ensure the power switch is set to the standby (O) position. This switch turns off the output voltage; it does not interrupt DC.
5. Remove the plastic cable cover from the power input terminals by using the Phillips (+) screwdriver, number 2, to loosen the screws (see [Figure 157 on page 290](#)).

**Figure 157: Removing the Plastic Cable Cover on a JNP10K-PWR-DC2 Power Supply**



6. Remove the nuts from each DC power input terminal, using the 13/32 in. (10 mm) nut driver or socket wrench to loosen the nuts.
7. Ensure that the power source circuit breaker is open so that the voltage across the DC power source cable leads is 0 V and that the cable leads do not become active while you are connecting DC power.
8. Verify that the DC power cables are correctly labeled before making connections to the power supply. In a typical power distribution scheme where the return is connected to chassis ground at the battery plant, you can use a multimeter to verify the resistance of the **-48V** and **RTN** DC cables to chassis ground:
  - The cable with very high resistance (indicating an open circuit) to chassis ground is negative (-) and will be installed on the **-48V** (input) DC power input terminal.

- The cable with very low resistance (indicating a closed circuit) to chassis ground is positive (+) and will be installed on the **RTN** (return) DC power input terminal.



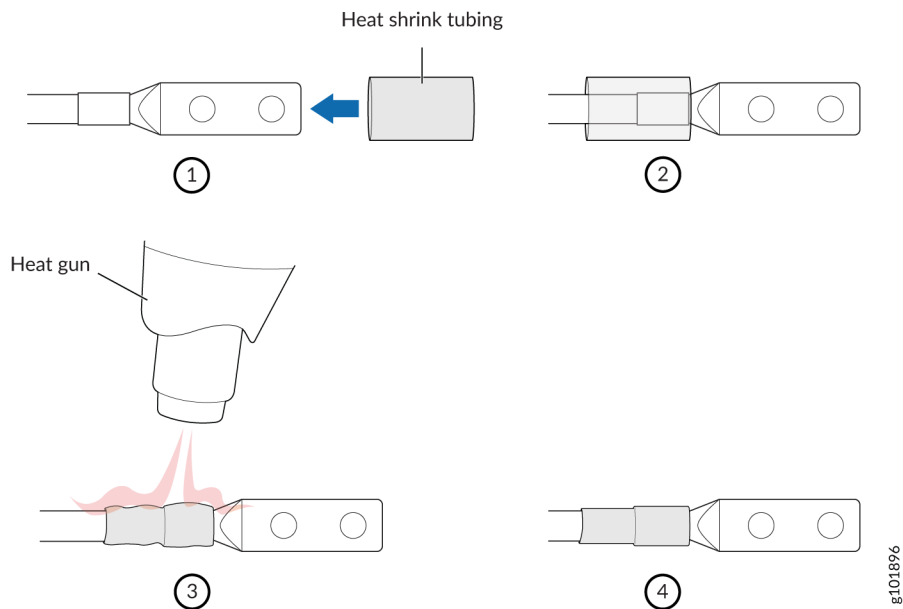
**CAUTION:** You must ensure that power connections maintain the proper polarity. The power source cables might be labeled (+) and (-) to indicate their polarity. There is no standard color coding for DC power cables.

9. Install heat-shrink tubing insulation around the power cables.
  - To install heat-shrink tubing:
    - a. Slide the tubing over the portion of the cable where it is attached to the lug barrel. Ensure that tubing covers the end of the wire and the barrel of the lug attached to it.
    - b. Shrink the tubing with a heat gun. Ensure that you heat all sides of the tubing evenly so that it shrinks around the cable tightly.

Figure 158 on page 291 shows the steps to install heat-shrink tubing.

**NOTE:** Do not overheat the tubing.

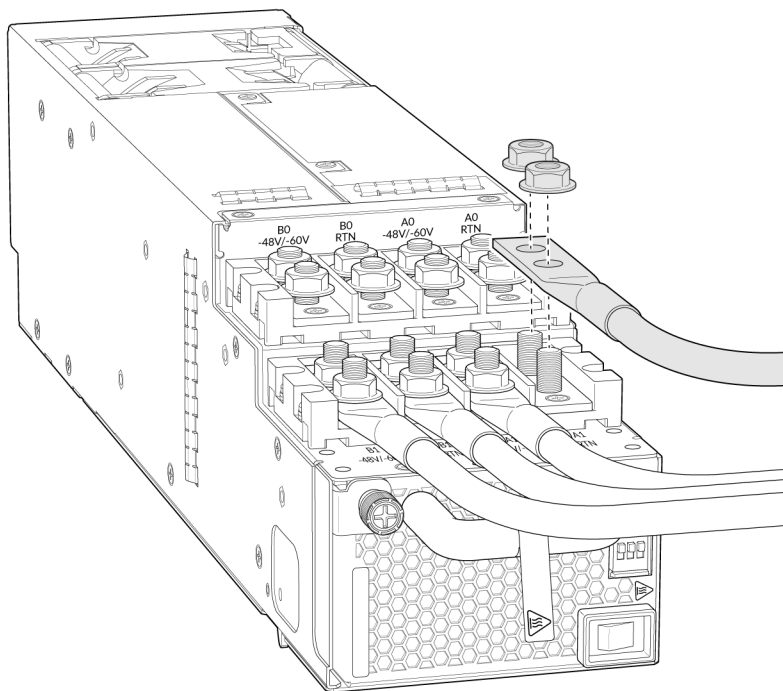
**Figure 158: How to Install Heat-Shrink Tubing**



10. Install each power cable lug on the DC power input terminal, securing it with the nut (see [Figure 159 on page 292](#)). Apply between 23 in.-lb (2.6 N-m) and 25 in.-lb (2.8 N-m) of torque to each nut. (Use the 13/32 in. [10 mm] nut driver or socket wrench.)
  - a. Secure each positive (+) DC source power cable lug to the **RTN** (return) DC power input terminal.
  - b. Secure each negative (-) DC source power cable lug to the **-48V** (input) DC power input terminal.

Each power supply has two independent sets of DC power input terminals (**INPUT 1: RTN -48V/-60V:** and **INPUT 2: : RTN -48V/-60V**). For feed redundancy, each power supply must be powered by dedicated power feeds derived from feed **INPUT 1** and feed **INPUT 2**. This configuration provides the commonly deployed INPUT 1 / INPUT 2 feed redundancy for the switch. There is basic insulation between the inputs and the chassis ground. Also, there is basic insulation between RTN input feeds.

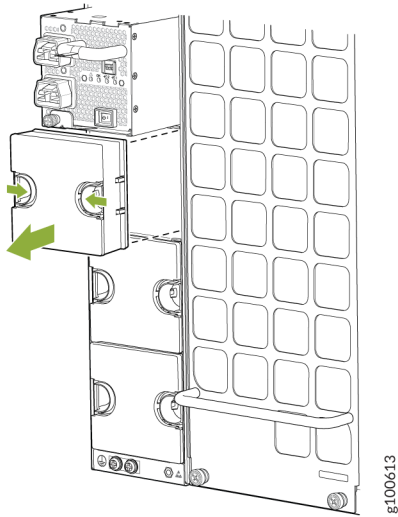
**Figure 159: Connecting the DC Power Supply Cables to a JNP10K-PWR-DC2**



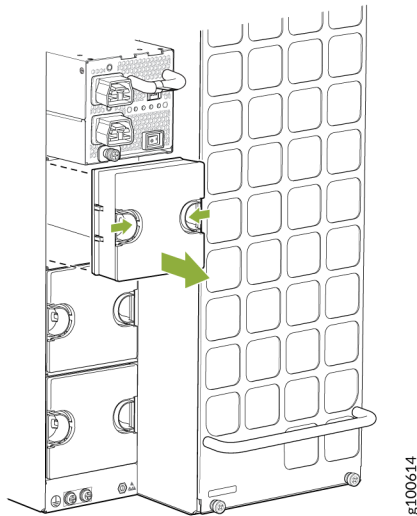
11. Install the plastic cable cover over each set of power cables by using the Phillips (+) screwdriver, number 2, to tighten the screw.

12. If the power supply slot on the chassis has a cover panel on it, insert your thumb and forefinger into the finger holes, squeeze, and pull the cover out of the slot. Save the cover panel for later use (see [Figure 160 on page 293](#) and [Figure 161 on page 293](#)).

**Figure 160: Removing the Power Supply Cover Panel on a QFX10008**



**Figure 161: Removing the Power Supply Cover Panel on a QFX10016**

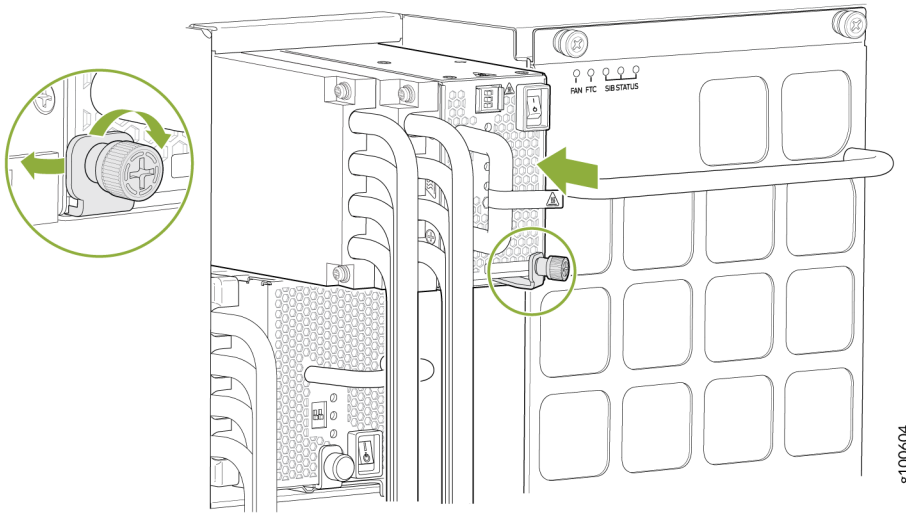


13. Unscrew the captive screw in the counterclockwise direction by using your fingers or by using the Phillips (+) screwdriver, number 1.
14. Rotate the captive screw away from the faceplate of the power supply to release the latch.





Figure 163: Installing a JNP10K-PWR-DC2 in QFX10016



- 18. Route INP1 cables to a power source and INP2 to another power source. The JNP10K-PWR-DC2 shares power, so if power dips on one input, the power supply is able to load balance internally. See [Figure 164 on page 295](#) and [Figure 165 on page 296](#).

Figure 164: Proper Load Balancing for JNP10K-PWR-DC2 Power Cables on QFX10008

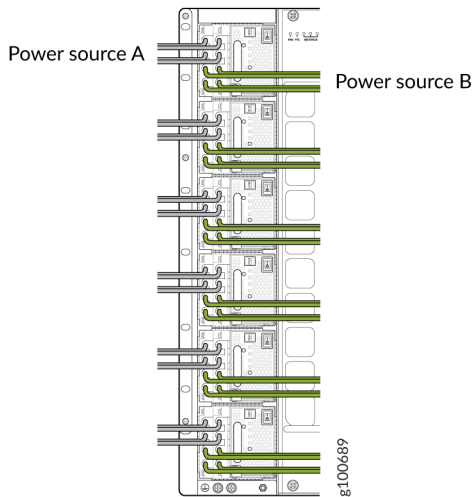
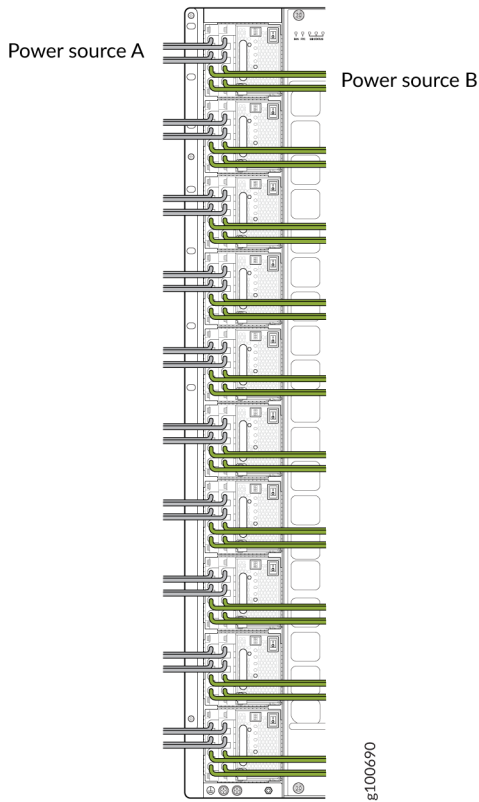


Figure 165: Proper Load Balancing for JNP10K-PWR-DC2 Power Cables on QFX100016



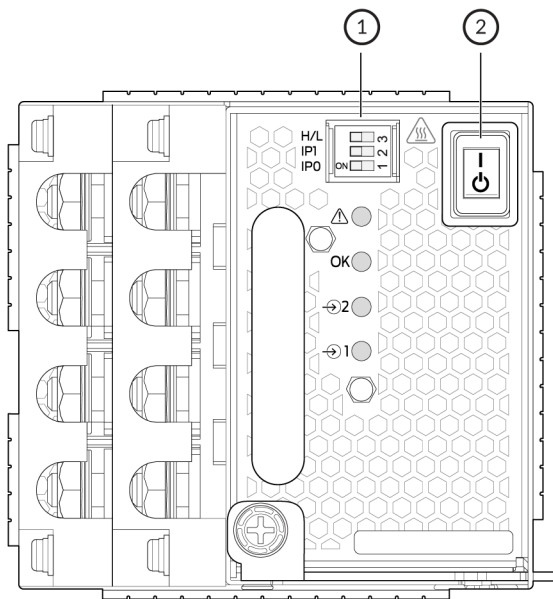
**WARNING:** Ensure that the power cables do not block access to router components or drape where people can trip on them. Always prevent cables from being exposed to hot air exhaust by routing them away from the fan trays and power supplies at the rear of the chassis.

19. Set the three DIP switches to set the inputs and whether the power supply is running at 3000 W or at 5500 W. See [Table 81 on page 297](#) and [Figure 166 on page 297](#).

Set both enable switches to the **on** position when using both source inputs. When not using source redundancy, set the unused source to the **O** (off) position. The LED turns red and indicates an error if a source input is not in use and the enable switch is | (on).

**Table 81: Setting the JNP10K-PWR-DC2 DIP Switches**

Switch	State	Field
1	On	IP0 is present
	Off	IP0 is not present
2	On	IP1 is present
	Off	IP1 is not present
3	On	Enabled for 30 A feed; 5500-W for a single feed, 5000-W for dual feeds
	Off	Enabled for 20 A feed; power supply capacity is 3000-W

**Figure 166: Setting the Enable Switches for the Power Source**

g100597

1– Dip switches

2– Power switch, on (I) and standby (O)

20. Verify that the input 1 and 2 LEDs on the power supply faceplate are lit and are on steadily.

21. Press the power switch to the on (I) position.

#### RELATED DOCUMENTATION

[QFX10000 AC Power System | 44](#)

[QFX10000 DC Power System | 65](#)

## Maintaining QFX10000 Switch Interface Boards

#### IN THIS SECTION

- [Removing a QFX10000 Switch Interface Board | 298](#)
- [Installing a QFX10000 Switch Interface Board | 303](#)

### Removing a QFX10000 Switch Interface Board

A QFX10008 and QFX10016 switch has six Switch Interface Boards (SIBs) that are located in the middle of the chassis behind the fan trays. **SIB 0** through **SIB 2** are located behind the left fan tray and **SIB 3** through **SIB 5** are located behind the right fan tray. You must remove the appropriate fan tray to access the failing SIB. See "[Removing a QFX10008 Fan Tray](#)" on [page 235](#).

Ensure you have the following equipment on hand before replacing a SIB:

- Electrostatic bag or antistatic mat
- Electrostatic discharge (ESD) grounding strap

To remove a SIB (see [Figure 170](#) on [page 301](#)):

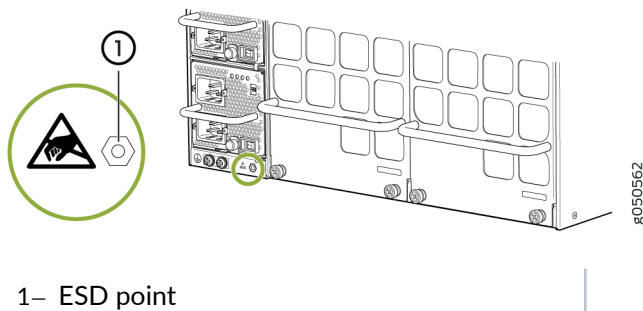
1. Take the SIB offline using the request chassis sib slot *slot number* offline command.

**NOTE:** If you suspect the SIB is faulty and want to ensure packets do not flow through the SIB, power down the SIB instead of taking the SIB offline. To power down the SIB, use the set

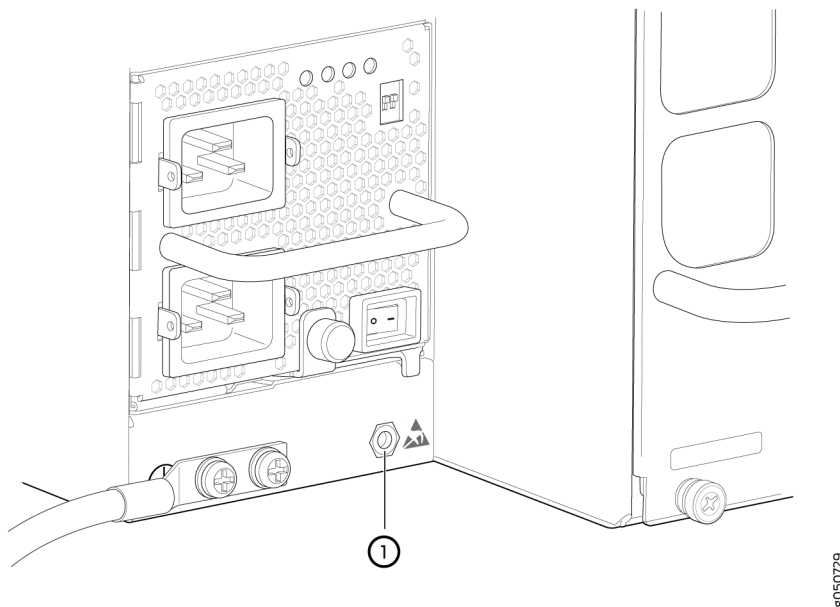
chassis sib power-off slot *slot number* command. To bring up a new SIB up in the slot, you must delete the old configuration using the delete chassis sib power-off slot *slot number* command.

2. Place an electrostatic bag or an antistatic mat on a flat, stable surface.
3. Attach the ESD grounding strap to your bare wrist, and connect the strap to the ESD point on the chassis. There is an ESD point located next to the protective earthing terminal and below **PSU 5** on the QFX10008 rear panel (see [Figure 167 on page 299](#)) and below **PSU\_9** on the QFX10016 (see [Figure 168 on page 299](#)).

**Figure 167: ESD Point on QFX10008 Chassis Rear**



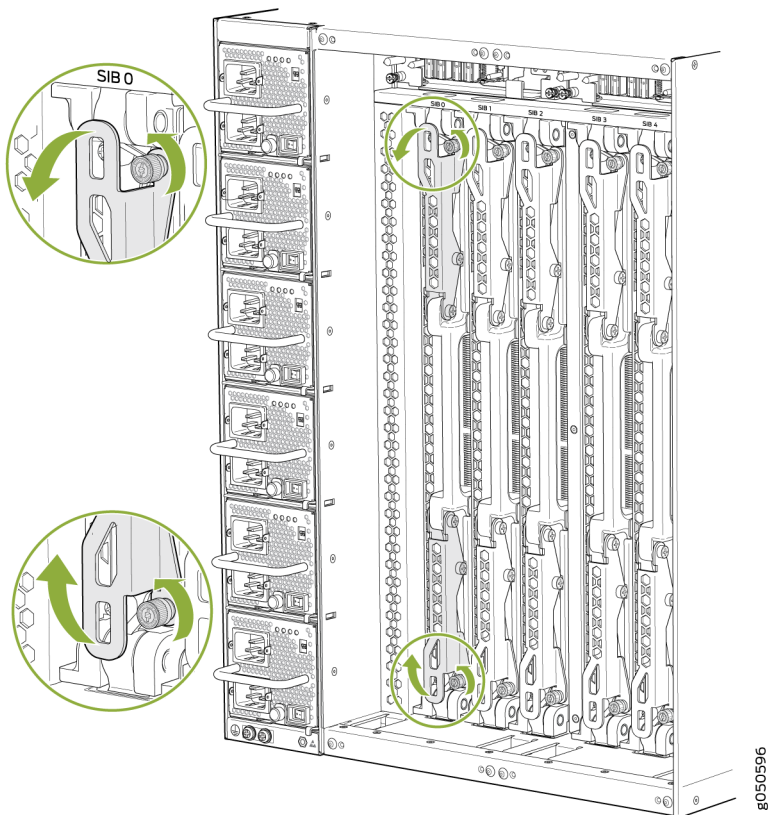
**Figure 168: ESD Point on QFX10016 Chassis Rear**



4. Remove the appropriate fan tray (see ["Removing a QFX10008 Fan Tray" on page 235](#)).

5. Loosen the captive screws at the top and bottom of the card.
6. Grasp both ejector handles and spread them apart. The SIB slides about a quarter of the way out of the slot. See [Figure 169 on page 300](#).

**Figure 169: Loosening Captive Screws and Spread Ejector Handles**



7. Grasp the ejector handle with one hand and place your other hand under the SIB for support as you slide the SIB out of the slot (see [Figure 170 on page 301](#) and [Figure 171 on page 302](#)).

Figure 170: Removing the SIB from a QFX10008 Chassis

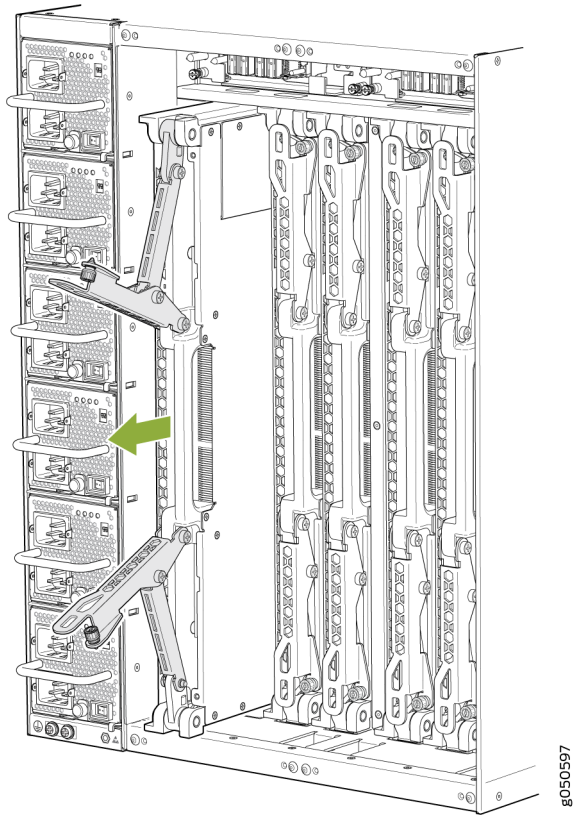
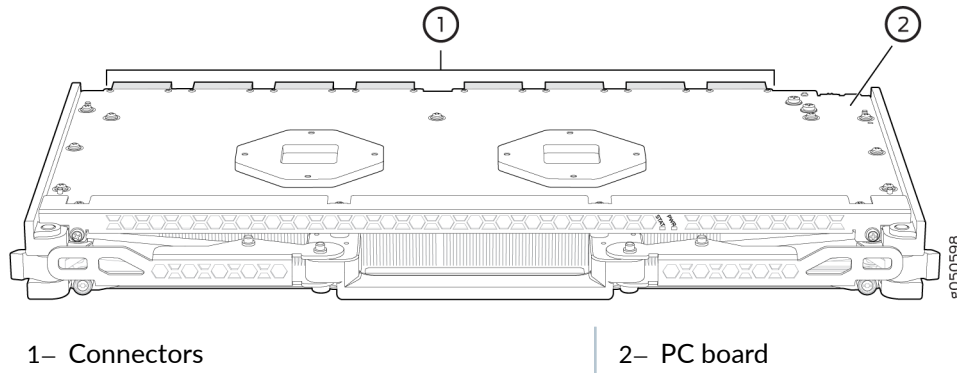






Figure 172: Extracted SIB



9. If you aren't replacing a SIB immediately, place a SIB cover into the vacant slot.

## SEE ALSO

[QFX10008 Switch Interface Board | 77](#)

[QFX10016 Switch Interface Board](#)

[QFX10000 Switch Interface Board LEDs](#)

## Installing a QFX10000 Switch Interface Board

A QFX10008 and QFX10016 switch has six Switch Interface Boards (SIBs) that are located in the middle of the chassis behind the fan trays. **SIB 0** through **SIB 2** are located behind the left fan tray, and **SIB 3** through **SIB 5** are located behind the right fan tray. You must remove the appropriate fan tray to install a SIB. See "[Removing a QFX10008 Fan Tray](#)" on page 235.

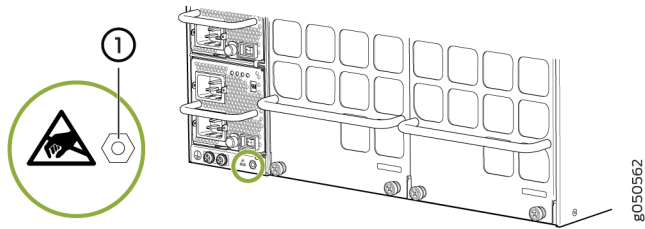
Ensure you have the following equipment on hand before installing a SIB:

- Electrostatic bag or antistatic mat
- Electrostatic discharge (ESD) grounding strap

To install a SIB:

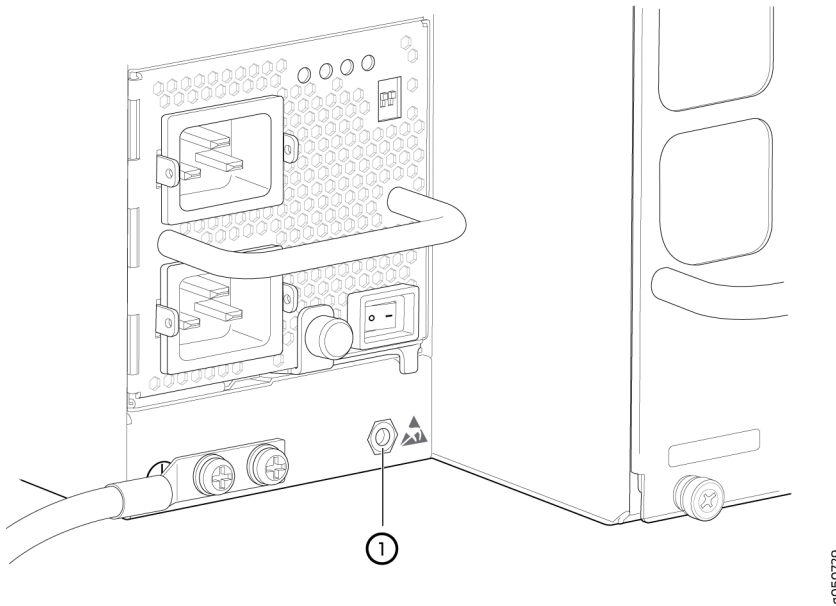
1. Place an electrostatic bag or an antistatic mat on a flat, stable surface.
2. Attach the ESD grounding strap to your bare wrist, and connect the strap to the ESD point on the chassis. There is an ESD point located next to the protective earthing terminal and below **PSU 5** on the QFX10008 rear panel (see [Figure 173 on page 304](#)) and below **PSU\_9** on the QFX10016 rear panel (see [Figure 174 on page 304](#)).

Figure 173: ESD Point on QFX10008 Chassis Rear



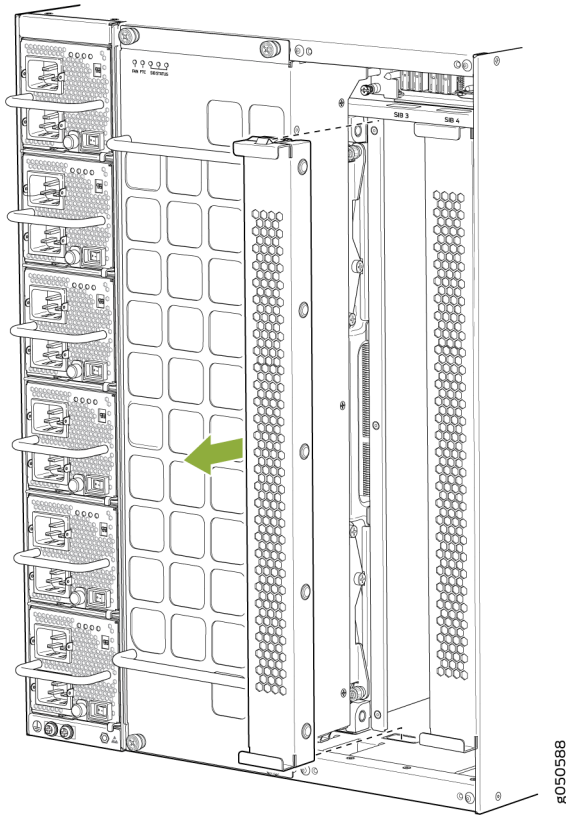
1– ESD point

Figure 174: ESD Point on QFX10016 Chassis Rear



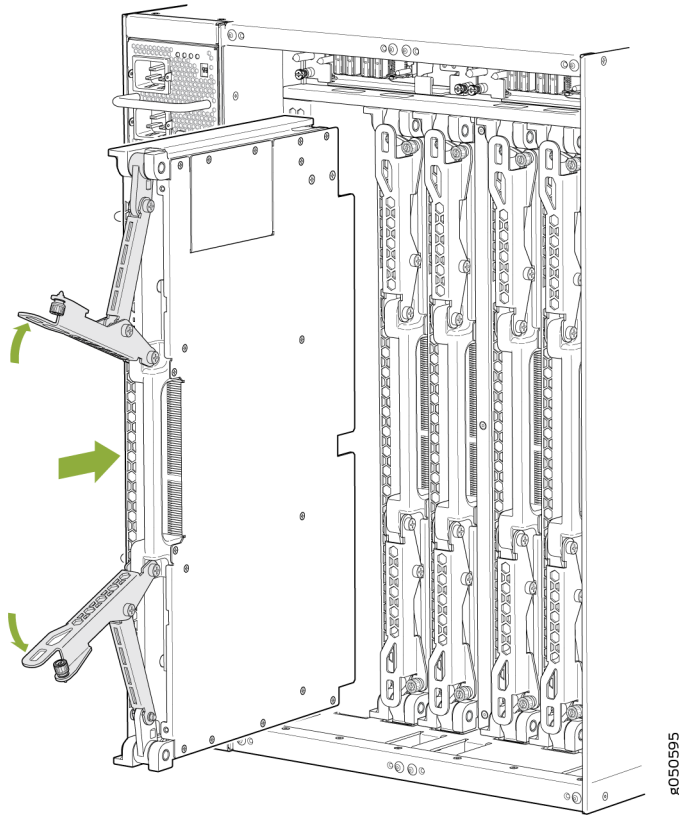
3. Remove the appropriate fan tray (see ["Removing a QFX10008 Fan Tray" on page 235](#)).
4. Either remove the failing SIB (see ["Removing a QFX10000 Switch Interface Board" on page 298](#)) or remove the cover by grasping each side of the plate and pulling straight out (see [Figure 175 on page 305](#) for an example using the QFX10008).

Figure 175: Removing a SIB Cover Plate on a QFX10008



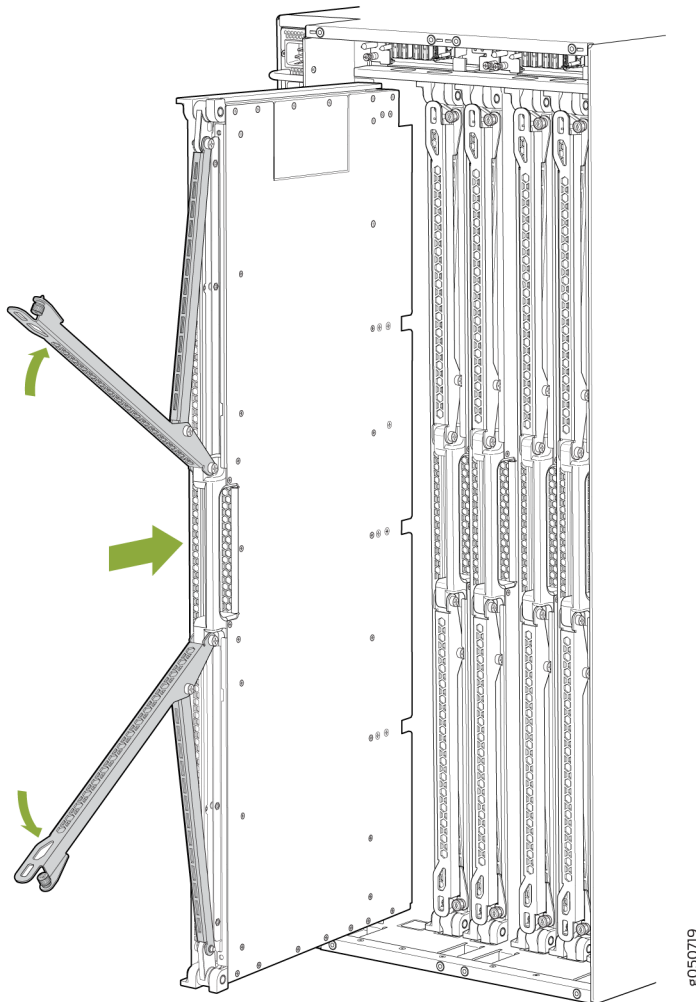
5. Lift the SIB by the handle with one hand and support the lower edge with the other hand.
6. Holding the SIB vertically, slide the SIB into the open slot until the ejector handles engage and start to close.
7. Grasp the two ejector handles and fold them inward until they latch to seat the SIB (see [Figure 176 on page 306](#) for the QFX10008 and [Figure 177 on page 307](#) for the QFX10016).

Figure 176: Installing a QFX10008 SIB



8050595

Figure 177: Installing a QFX10016 SIB



8. Hand-tighten the captive screws.
9. Bring the SIB online using the request chassis sib slot *sSlot number* online command.

You can check the status of the SIB using the show chassis fabric sibs and the show chassis fabric plane-location commands. For example:

```

root> show chassis fabric sibs
Fabric management SIB state:
SIB #0 Online
  FASIC #0 (plane 0) Active
    FPC #0
      PFE #0 : OK
      PFE #1 : OK
      PFE #2 : OK

```

```

    PFE #3 : OK
    PFE #4 : OK
    PFE #5 : OK
  FPC #3
    PFE #0 : OK
    PFE #1 : OK
    PFE #2 : OK
    PFE #3 : OK
    PFE #4 : OK
    PFE #5 : OK
  FASIC #1 (plane 1) Active
    FPC #0
      PFE #0 : OK
      PFE #1 : OK
      PFE #2 : OK
      PFE #3 : OK
      PFE #4 : OK
      PFE #5 : OK
    FPC #3
      PFE #0 : OK
      PFE #1 : OK
      PFE #2 : OK
      PFE #3 : OK
      PFE #4 : OK
      PFE #5 : OK
  SIB #1 Empty
  SIB #2 Empty
  SIB #3 Empty
  SIB #4 Empty
  SIB #5 Empty

```

```
root> show chassis fabric plane-location
```

```

-----Fabric Plane Locations-----
SIB      Planes
  0        0   1
  1        2   3
  2        4   5
  3        6   7
  4        8   9
  5       10  11

```

**NOTE:** If you completely powered off the SIB using the `set chassis sib power-off slot slot` command, you must delete the configuration in order to bring the SIB online. To delete the configuration and bring a replacement SIB online, use the `delete chassis sib power-off slot slot number` command.

## SEE ALSO

[Removing a QFX10008 Fan Tray | 235](#)

[Removing a QFX10000 Switch Interface Board | 298](#)

## RELATED DOCUMENTATION

[Removing a QFX10008 Fan Tray | 235](#)

[QFX10008 Switch Interface Board | 77](#)

# Maintaining QFX10000 Line Cards

## IN THIS SECTION

- [Removing a QFX10000 Line Card | 309](#)
- [Installing a QFX10000 Line Card | 313](#)
- [Installing the QFX10000 Cable Management System | 316](#)

## Removing a QFX10000 Line Card

QFX10000 line cards are field-replaceable units (FRUs) that can be installed in the line card slots on the front of the chassis. The line cards are hot-insertable and hot-removable: you can remove and replace them without powering off the switch or disrupting switch functions. However, we recommend that you take them offline before removing them.



If you have the optional line-card cable management system, it is not necessary to remove the cable management system before removing the line card.

Before you remove a line card from the switch chassis:

- Ensure that you have taken the necessary precautions to prevent electrostatic discharge (ESD) damage. See [Prevention of Electrostatic Discharge Damage](#).
- If there are any optical cables, (including transceivers, direct-attach copper (DAC), or DAC break-out) installed in the line card), remove them before you remove the line card. See ["Removing a Transceiver" on page 323](#).
- Ensure that you know how to handle and store the line card. See ["Unpacking QFX10000 Line Cards, Routing and Control Boards, and Switch Interface Boards" on page 189](#).

Ensure that you have the following parts and tools available to remove a line card from a QFX10000 chassis:

- ESD grounding strap
- An electrostatic bag or an antistatic mat

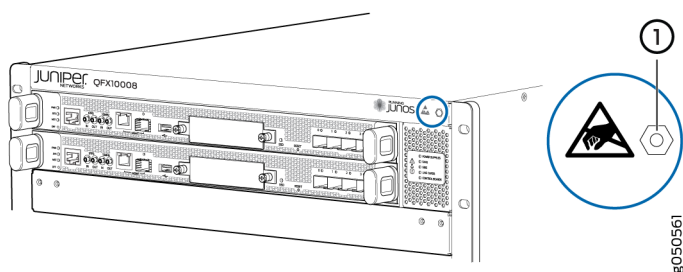
**NOTE:** Placing a line card in an electrostatic bag might require a second person to assist with sliding the line card into the bag.

- Replacement line card or a cover for the empty slot

To remove a line card from a QFX10000 switch chassis:

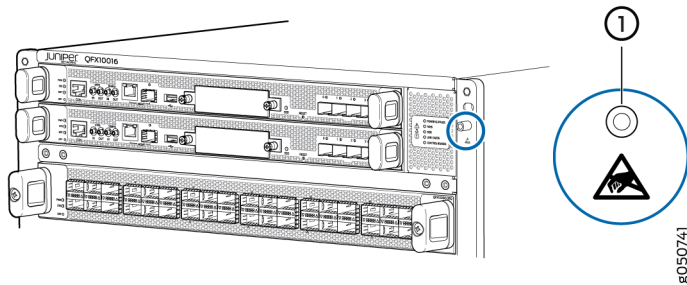
1. Place the antistatic bag or antistatic mat on a flat, stable surface.
2. Attach the ESD grounding strap to your bare wrist and connect the strap to the ESD point above the status LEDs on the switch chassis (see [Figure 178 on page 310](#)).

**Figure 178: ESD Point on QFX10008 Chassis Front**



1- ESD point

Figure 179: ESD Point on QFX10016 Chassis Front



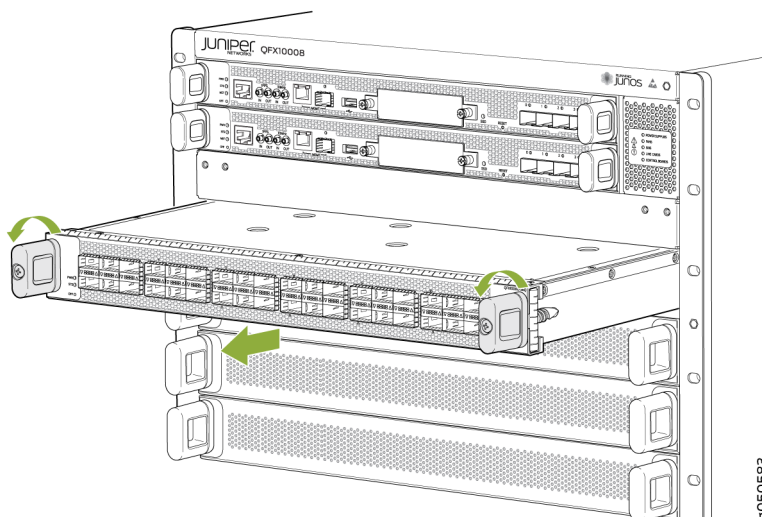
1– ESD point

3. Label the cables connected to each port on the line card so you can reconnect the cables to the correct ports.
4. Take the line card offline by issuing the following CLI command:

```
user@switch> request chassis fpc slot slot-number offline
```

5. Unscrew the line card from the chassis by continually turning the handles to the left until the line card is fully unseated. See [Figure 180 on page 311](#).

Figure 180: Removing a QFX10000 Line Card



6. Using the handles, slide the line card halfway out of the chassis.



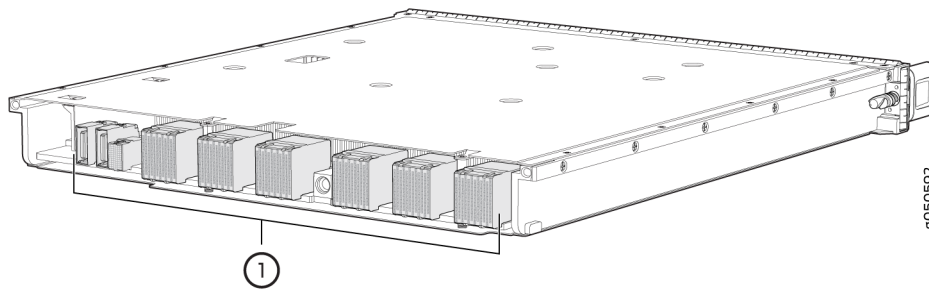
**CAUTION:** Do not stack line cards on top of one another or on top of any other component. Place each line card separately in the electrostatic bag or on the antistatic mat placed on a flat, stable surface.



**CAUTION:** Each QFX10000 line card weighs between 20.9 lb (9.5 kg) and 27.3 lb (12.4 kg). Be prepared to support the full weight as you slide the line card out of the chassis.

7. Grasp both sides of line card at midpoint and remove the line card from the chassis. Either have someone assist you in putting the line card into the electrostatic bag or rest the card on the antistatic mat. Take care not to bump or store the line cards on the connectors. See [Figure 181 on page 312](#).

**Figure 181: QFX10000 Line Card Connectors**



1– Connectors

8. If you are not installing a line card in the emptied line card slot within a short time, install a cover over the slot. Do this to protect the interior of the chassis from dust or other foreign substances and to ensure that the airflow inside the chassis is not disrupted.

## SEE ALSO

| [QFX10000 Line Cards](#) | 88

## Installing a QFX10000 Line Card

QFX10000 line cards are field-replaceable units (FRUs) that can be installed in any of the line card slots on the front of the chassis. The line cards are hot-insertable and hot-removable: you can remove and replace them without powering off the switch or disrupting switch functions.

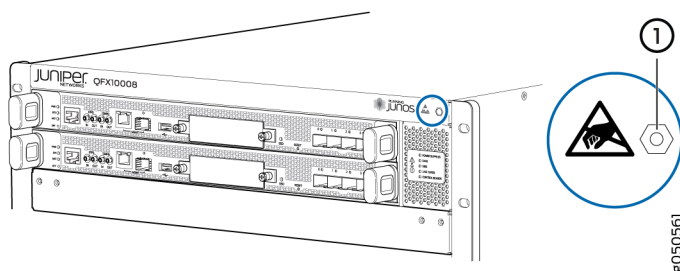
Before you install a line card in the switch chassis:

- Ensure that you have taken the necessary precautions to prevent electrostatic discharge (ESD) damage. See [Prevention of Electrostatic Discharge Damage](#).
- Ensure that you know how to handle and store the line card. See ["Handling and Storing QFX10000 Line Cards, RCBs, and SIBs" on page 226](#).
- Inspect the connector edge of the line card for physical damage. Installing a damaged line card might damage the switch.
- Ensure that the switch has sufficient power to power the line card while maintaining its  $N+1$  power redundancy. To determine whether the switch has enough power available for the line card, use the `show chassis power-budget-statistics` command. See also ["Power Requirements for QFX10000 Components" on page 163](#).
- Ensure that you have the following parts and tools available to install a line card in the switch:
  - ESD grounding strap
  - Phillips (+) screwdriver, number 2

To install a line card in the switch chassis:

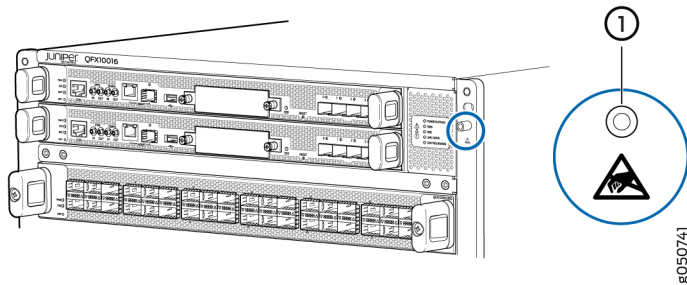
1. Attach the ESD grounding strap to your bare wrist and connect the strap to the ESD point on the switch chassis. The ESD point is located above the status LED panel on the front of the switch chassis. See [Figure 182 on page 313](#) and [Figure 183 on page 314](#).

Figure 182: ESD Point on QFX10008 Chassis Front



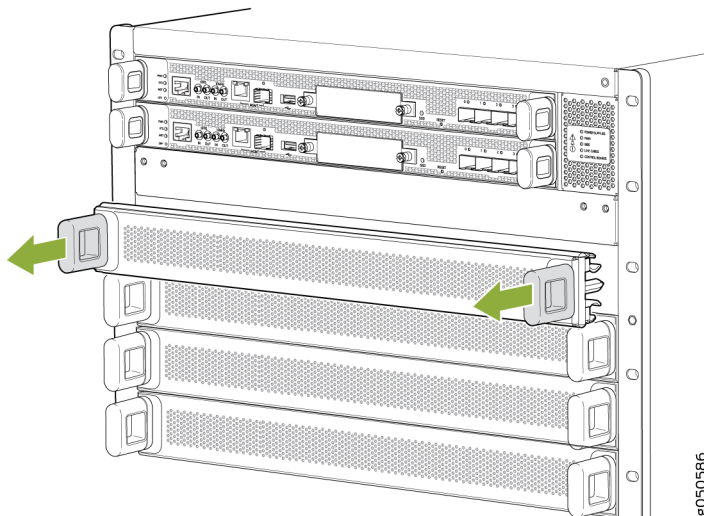
1– ESD point

Figure 183: ESD Point on QFX10016 Chassis Front



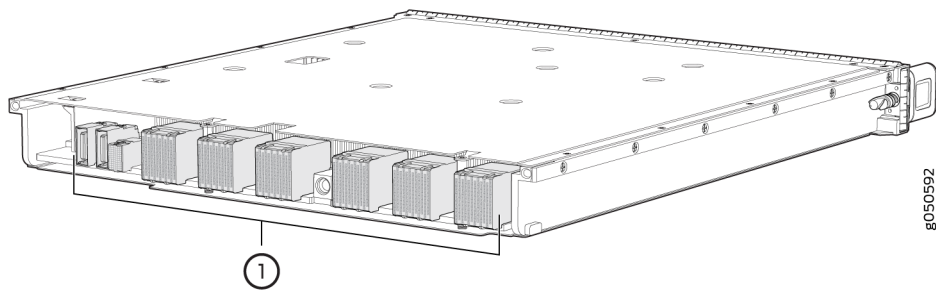
2. Remove the cover panel by grasping the handles and pulling straight out to expose the slot for the line card. See [Figure 184 on page 314](#).

Figure 184: Removing the Cover for a Line Card



**CAUTION:** Do not lift the line card by holding the edge connectors or the handles on the faceplate. Neither the handles or the edge connectors can support the weight of the line card. Lifting the line card by the handles or edge connectors might bend them, which would prevent the line cards from being properly seated in the chassis. See [Figure 185 on page 315](#).

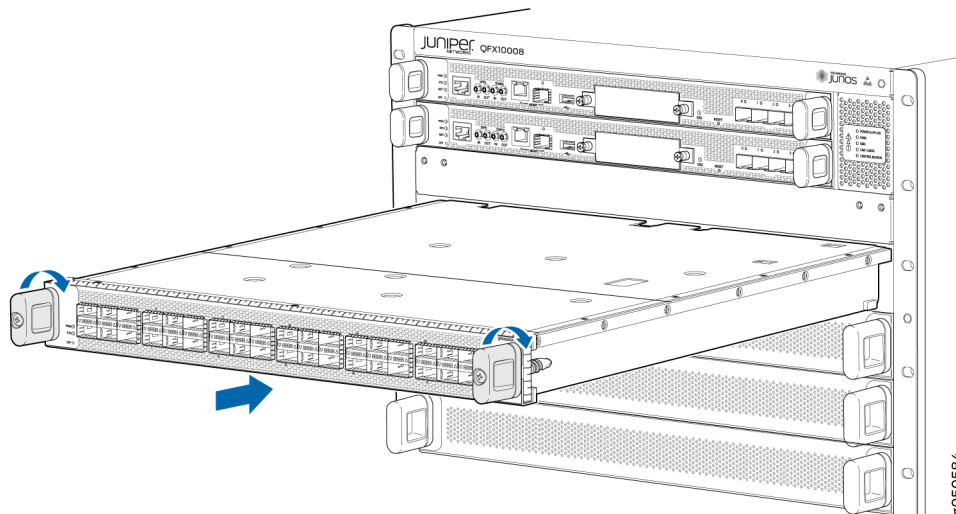
Figure 185: Line Card Connectors



1– Connectors

3. Remove the line card from the electrostatic bag and inspect it for any damage before installing it into the chassis.
4. Grasp and lift the line card by the sides.
5. Slide the line card all the way into the slot until the handle holes align. See [Figure 186 on page 315](#).

Figure 186: Inserting a Line Card into the Slot and Rotating the Handles



6. Screw the line card into the chassis by rotating the handles until the card is fully seated and the handles are vertical.
7. Bring the line card online:

```
user@switch> request chassis fpc slot slot-number online
```

You can install the optional cable management kit after the card is installed.

## SEE ALSO

[Power Requirements for QFX10000 Components](#) | 163

## Installing the QFX10000 Cable Management System

The QFX10000 cable management system is an optional kit that can be ordered to organize and protect optical cabling attached to the line cards. After a card is installed, you can still remove the line card without needing to remove the cable management system.

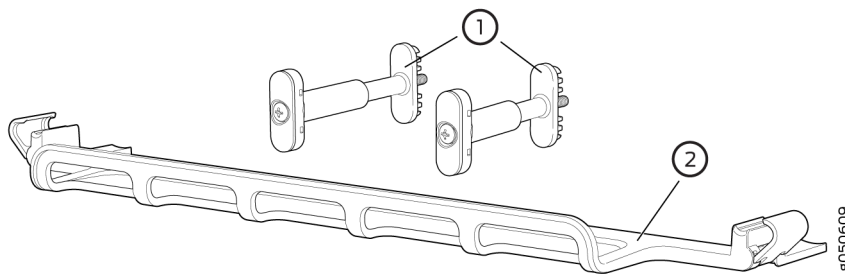
Ensure that you have the following parts and tools available to install the QFX10000 cable management system on a line card:

- Phillips (+) screwdriver, number 2

To install the cable management system (see [Figure 187 on page 316](#)):

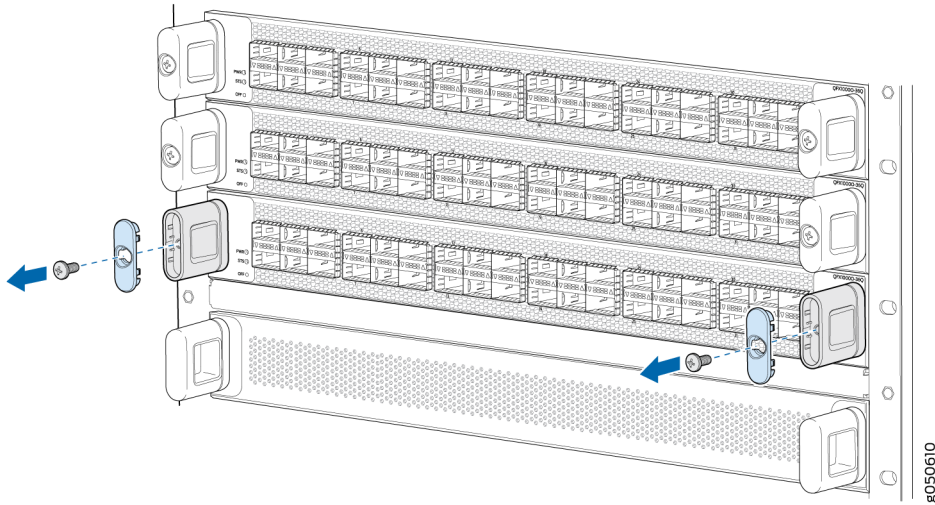
1. Open the shipping carton for cable management system and check that you have:
  - Two handle extensions
  - One cable tray

**Figure 187: Cable Management System Components**



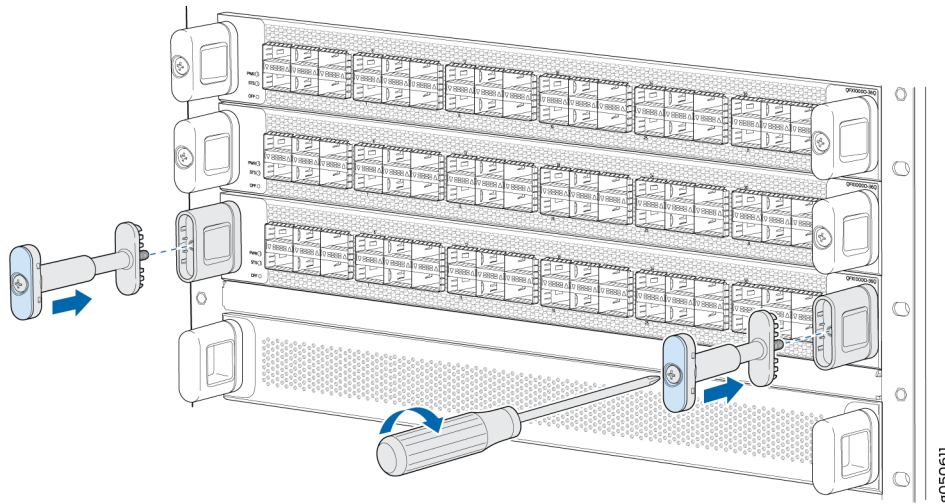
2. Use the Phillips screwdriver to loosen and remove the screws on the two line card handles (see [Figure 188 on page 317](#)).

**Figure 188: Removing the Handle Screws**



3. Replace the blue cap on the line card handle with the two handle extensions (see [Figure 189 on page 317](#)).

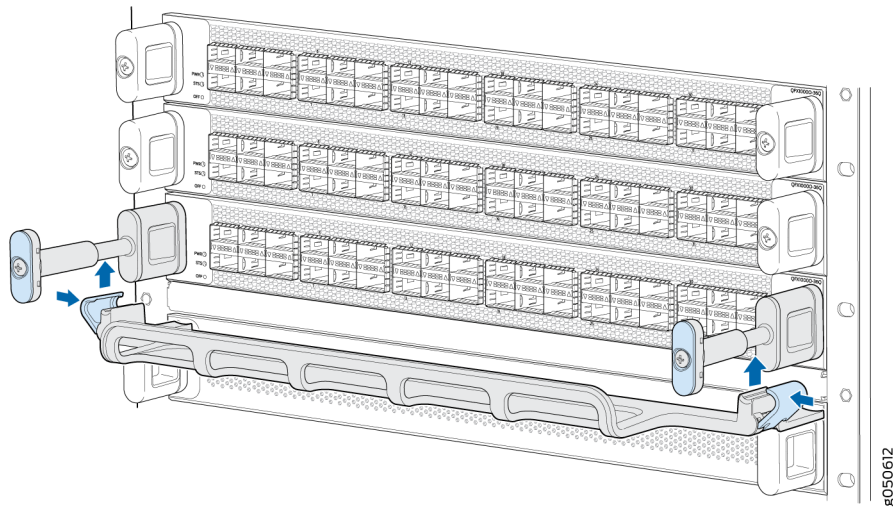
**Figure 189: Adding Handle Extensions**



4. Tighten the screws into the handle extensions.
5. Snap open the blue clips on the ends of the cable tray with your hands.
6. Place the cable tray across the front of the line card so that the two ends of the cable tray are under the handle extensions.
7. Snap to close the blue clips of the cable tray around the handle extensions (see [Figure 190 on page 318](#)).

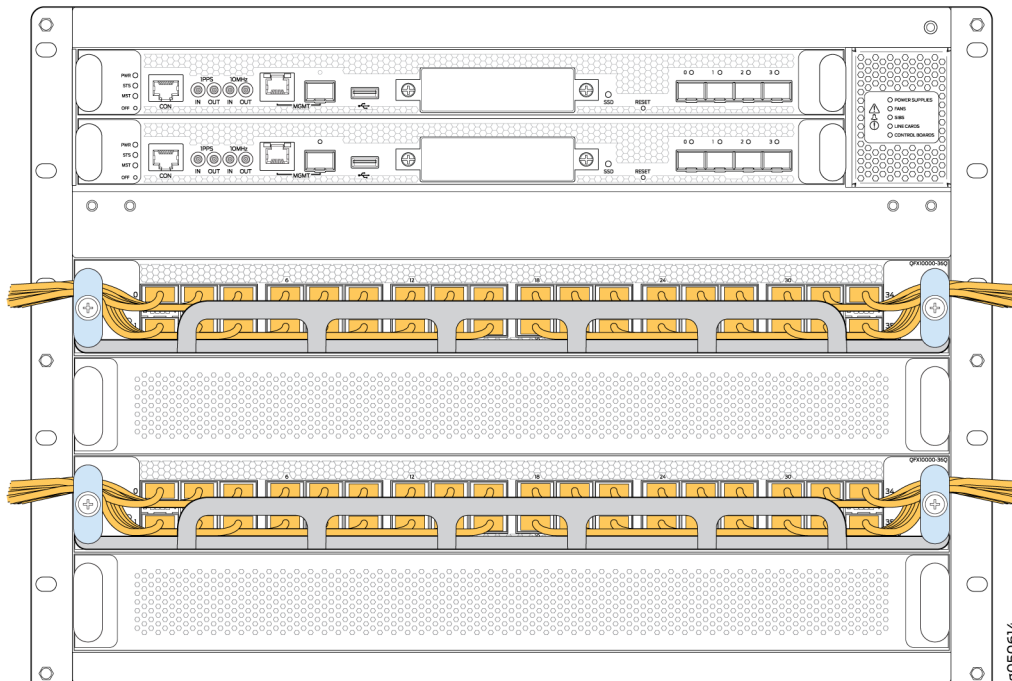


Figure 190: Adding the Cable Tray



8. Drape and tie the optical cables to the side (see [Figure 191 on page 318](#)). Another option is to drape some of the cables under the handle extension and some cables over the handle extension.

Figure 191: Completed Cable Management System



## SEE ALSO

[QFX10000 Optional Equipment | 29](#)

[QFX10000 EMI Front Panel | 27](#)

## RELATED DOCUMENTATION

[Handling and Storing QFX10000 Line Cards, RCBs, and SIBs | 226](#)

# Maintaining QFX10000 Solid State Drives

## IN THIS SECTION

- [Removing the Optional SATA Solid State Drive in a QFX10000 | 319](#)
- [Installing the Optional SATA Solid State Drive in a QFX10000 | 321](#)

## Removing the Optional SATA Solid State Drive in a QFX10000

The QFX100000 allows optional installation of either a 50 GB or a 100 GB serial advanced technology attachment (SATA) solid state drive (SSD) as a secondary boot drive or for log storage. The SATA SSD is a field-replaceable unit (FRU).

Before you remove an SATA SSD from the switch:

- Drain traffic queues to prevent traffic loss.
- Ensure that you understand how to prevent ESD damage. See [Prevention of Electrostatic Discharge Damage](#).

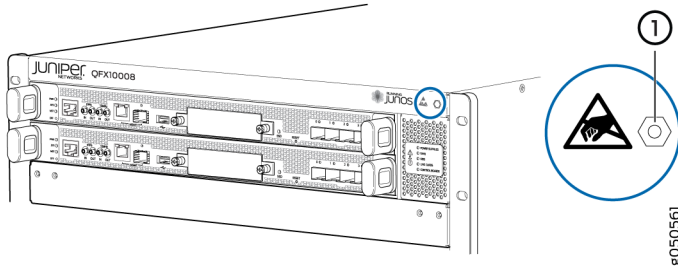
Ensure that you have the following parts and tools available to remove an SATA SSD from a QFX10000:

- Electrostatic discharge (ESD) grounding strap
- Phillips (+) screwdriver, number 1
- An electrostatic bag or antistatic mat

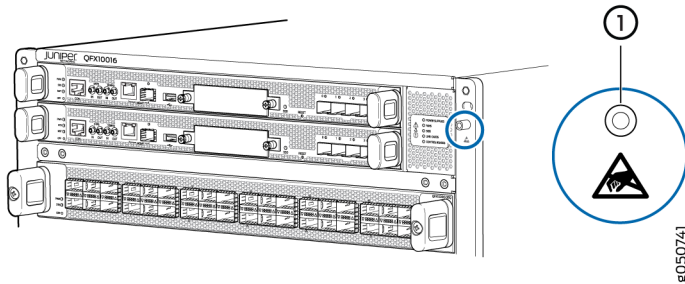
To remove either size of SATA SSD in a QFX10000:

1. Attach the ESD grounding strap to your bare wrist, and connect the strap to the ESD point on the chassis. There is an ESD point located above the status LED panel on the right side of the switch chassis (see [Figure 192 on page 320](#) and [Figure 193 on page 320](#)).

**Figure 192: ESD Point on QFX10008 Chassis Front**



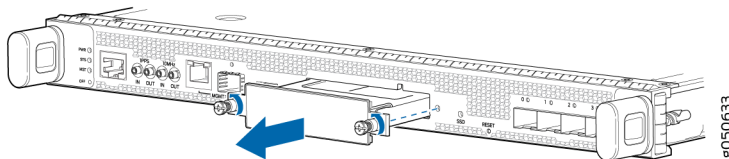
**Figure 193: ESD Point on QFX10016 Chassis Front**



1– ESD point

2. Loosen the two captive screws of the SATA SSD on the control panel by using the Phillips (+) screwdriver, number 1.
3. Grasp the faceplate of the SATA SSD by the captive screws and slide the drive out of the control panel (see [Figure 194 on page 320](#)).

**Figure 194: Removing the SATA SSD**



4. Place the SATA SSD in an electrostatic bag or on an antistatic mat.
5. Replace the drive with either a new SATA SSD or with a slot cover.



**CAUTION:** A drive or cover must be in place to prevent dust contamination.

6. Tighten the captive screws of the cover plate or replacement SATA SSD.

## Installing the Optional SATA Solid State Drive in a QFX10000

The QFX100000 allows optional installation of either a 50 GB or a 100 GB serial advanced technology attachment (SATA) solid state drive (SSD) as a secondary boot drive or for log storage. The SATA SSD is a field-replaceable unit (FRU).

Before you install an SATA SSD in the switch, ensure you that understand how to prevent ESD damage. See [Prevention of Electrostatic Discharge Damage](#).

Ensure that you have the following parts and tools available to install an SATA SSD in a QFX10000:

- Electrostatic discharge (ESD) grounding strap
- Phillips (+) screwdriver, number 1

To install either size of SATA SSD in a QFX10000:

1. Attach the ESD grounding strap to your bare wrist, and connect the strap to the ESD point on the front of the chassis. There is an ESD point located above the status LED panel on the right side (see [Figure 195 on page 321](#) and [Figure 196 on page 322](#)).

**Figure 195: ESD Point on QFX10008 Chassis Front**

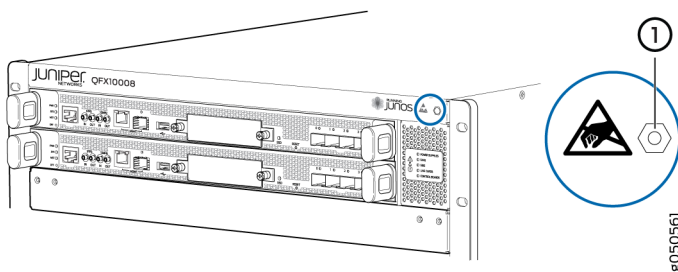
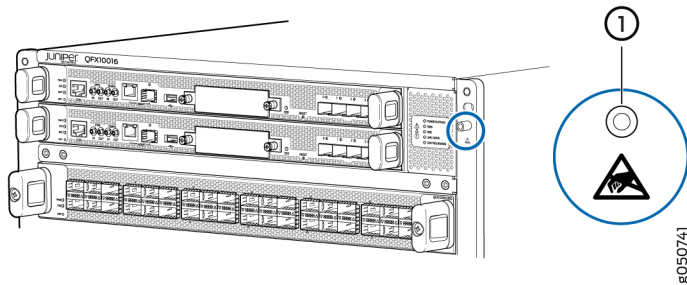


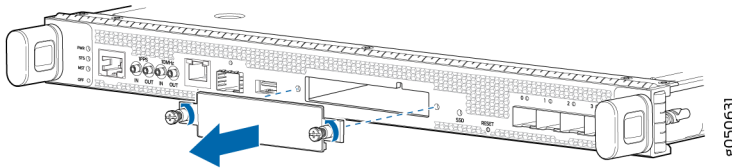
Figure 196: ESD Point on QFX10016 Chassis Front



1– ESD point

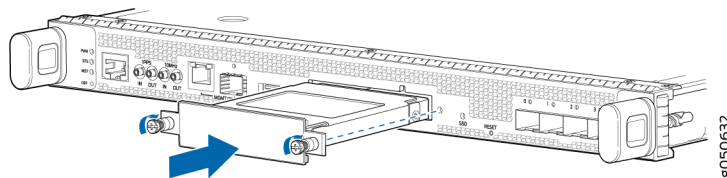
2. Loosen the two captive screws to remove the cover on the RCB by using the Phillips (+) screwdriver, number 1 (see [Figure 197 on page 322](#)).

Figure 197: Removing the SATA SSD Cover



3. Remove the SATA SSD from the electrostatic bag, taking care not to touch the connectors.
4. Slide the SATA SSD into the open slot until the pins engage and the faceplate is flush with the front panel of the Control Board (see [Figure 198 on page 322](#)).

Figure 198: Installing the SATA SSD into the Slot



5. Tighten the two captive screws on the faceplate until hand-tight using the Phillips (+) screwdriver, number 1.

## RELATED DOCUMENTATION

QFX10000 Optional Equipment | 29

# Maintaining Transceivers and Fiber-Optic Cables on QFX10000

## IN THIS SECTION

- [Removing a Transceiver | 323](#)
- [Install a Transceiver | 325](#)
- [Disconnect a Fiber-Optic Cable | 329](#)
- [Connect a Fiber-Optic Cable | 329](#)
- [How to Handle Fiber-Optic Cables | 330](#)

## Removing a Transceiver

Before you begin to remove a transceiver from a device, ensure that you have taken the necessary precautions for safe handling of lasers (see [Laser and LED Safety Guidelines and Warnings](#)).

Ensure that you have the following parts and tools available:

- An antistatic bag or an antistatic mat
- Rubber safety caps to cover the transceiver and fiber-optic cable connector
- A dust cover to cover the port or a replacement transceiver

The transceivers for Juniper Networks devices are hot-removable and hot-insertable field-replaceable units (FRUs). You can remove and replace them without powering off the device or disrupting device functions.

**NOTE:** After you remove a transceiver or when you change the media-type configuration, wait for 6 seconds for the interface to display the operational commands.

[Figure 199 on page 325](#) shows how to remove a QSFP+ transceiver. The procedure is the same for all types of transceivers except the QSFP28 and CFP transceivers.

To remove a transceiver from a device:

1. Place the antistatic bag or antistatic mat on a flat, stable surface.
2. Wrap and fasten one end of the ESD wrist strap around your bare wrist, and connect the other end of the strap to the ESD point on the switch.
3. Label the cable connected to the transceiver so that you can reconnect it correctly.



**LASER WARNING:** Do not look directly into a fiber-optic transceiver or into the ends of fiber-optic cables. Fiber-optic transceivers and fiber-optic cables connected to transceivers emit laser light that can damage your eyes.



**LASER WARNING:** Do not leave a fiber-optic transceiver uncovered except when inserting or removing a cable. The rubber safety cap keeps the port clean and prevents accidental exposure to laser light.



**CAUTION:** Do not bend fiber-optic cables beyond their minimum bend radius. An arc smaller than a few inches in diameter can damage the cables and cause problems that are difficult to diagnose.

4. Remove the cable connected to the transceiver (see [Disconnect a Fiber-Optic Cable](#)). Cover the transceiver and the end of each fiber-optic cable connector with a rubber safety cap immediately after disconnecting the fiber-optic cables.
5. To remove an SFP, SFP+, XFP, or a QSFP+ transceiver:
  - a. By using your fingers, pull open the ejector lever on the transceiver to unlock the transceiver.



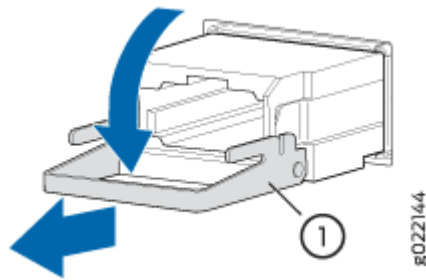
**CAUTION:** Before removing the transceiver, make sure that you open the ejector lever completely until you hear it click. This prevents damage to the transceiver.

- b. Grasp the transceiver ejector lever and gently slide the transceiver approximately 0.5 in. (1.3 cm) straight out of the port.



**CAUTION:** To prevent electrostatic discharge (ESD) damage to the transceiver, do not touch the connector pins at the end of the transceiver.

Figure 199: Removing an SFP, SFP+, XFP, or a QSFP+ Transceiver



1– Ejector lever

To remove a CFP transceiver:

- a. Loosen the screws on the transceiver by using your fingers.
- b. Grasp the screws on the transceiver and gently slide the transceiver approximately 0.5 in. (1.3 cm) straight out of the port.



**CAUTION:** To prevent electrostatic discharge (ESD) damage to the transceiver, do not touch the connector pins at the end of the transceiver.

6. By using your fingers, grasp the body of the transceiver and pull it straight out of the port.
7. Place the transceiver in the antistatic bag or on the antistatic mat placed on a flat, stable surface.
8. Place the dust cover over the empty port or install the replacement transceiver.

## Install a Transceiver

Before you install a transceiver in a device, ensure that you have taken the necessary precautions for safe handling of lasers (see [Laser and LED Safety Guidelines and Warnings](#)).

Ensure that you have a rubber safety cap available to cover the transceiver.

The transceivers for Juniper Networks devices are hot-removable and hot-insertable field-replaceable units (FRUs). You can remove and replace the transceivers without powering off the device or disrupting the device functions.

**NOTE:** After you insert a transceiver or after you change the media-type configuration, wait for 6 seconds for the interface to display operational commands.



**NOTE:** We recommend that you use only optical transceivers and optical connectors purchased from Juniper Networks with your Juniper Networks device.



**CAUTION:** The Juniper Networks Technical Assistance Center (JTAC) provides complete support for Juniper-supplied optical modules and cables. However, JTAC does not provide support for third-party optical modules and cables that are not qualified or supplied by Juniper Networks. If you face a problem running a Juniper device that uses third-party optical modules or cables, JTAC may help you diagnose host-related issues if the observed issue is not, in the opinion of JTAC, related to the use of the third-party optical modules or cables. Your JTAC engineer will likely request that you check the third-party optical module or cable and, if required, replace it with an equivalent Juniper-qualified component.

Use of third-party optical modules with high-power consumption (for example, coherent ZR or ZR+) can potentially cause thermal damage to or reduce the lifespan of the host equipment. Any damage to the host equipment due to the use of third-party optical modules or cables is the users' responsibility. Juniper Networks will accept no liability for any damage caused due to such use.

Figure 200 on page 328 shows how to install a QSFP+ transceiver. The procedure is the same for all types of transceivers except the QSFP28 and CFP transceivers.

To install a transceiver:



**CAUTION:** To prevent electrostatic discharge (ESD) damage to the transceiver, do not touch the connector pins at the end of the transceiver.

1. Wrap and fasten one end of the ESD wrist strap around your bare wrist, and connect the other end of the strap to the ESD point on the switch.
2. Remove the transceiver from its bag.
3. Check to see whether the transceiver is covered with a rubber safety cap. If it is not, cover the transceiver with a rubber safety cap.



**LASER WARNING:** Do not leave a fiber-optic transceiver uncovered except when inserting or removing a cable. The rubber safety cap keeps the port clean and protects your eyes from accidental exposure to laser light.

4. If the port in which you want to install the transceiver is covered with a dust cover, remove the dust cover and save it in case you need to cover the port later. If you are hot-swapping a transceiver, wait for at least 10 seconds after removing the transceiver from the port before installing a new transceiver.
5. Using both hands, carefully place the transceiver in the empty port. The connectors must face the chassis.



**CAUTION:** Before you slide the transceiver into the port, ensure that the transceiver is aligned correctly. Misalignment might cause the pins to bend, making the transceiver unusable.

6. Slide the transceiver in gently until it is fully seated. If you are installing a CFP transceiver, use your fingers to tighten the captive screws on the transceiver.
7. Remove the rubber safety cap from the transceiver and the end of the cable, and insert the cable into the transceiver.



**LASER WARNING:** Do not look directly into a fiber-optic transceiver or into the ends of fiber-optic cables. Fiber-optic transceivers and fiber-optic cable connected to a transceiver emit laser light that can damage your eyes.



**CAUTION:** Do not leave a fiber-optic transceiver uncovered except when inserting or removing cable. The safety cap keeps the port clean and protects your eyes from accidental exposure to laser light.

8. If there is a cable management system, arrange the cable in the cable management system to prevent the cable from dislodging or developing stress points. Secure the cable so that it does not support its own weight as it hangs toward the floor. Place excess cable out of the way in a neatly coiled loop in the cable management system. Placing fasteners on the loop helps to maintain its shape.



**CAUTION:** Do not let fiber-optic cable hang free from the connector. Do not allow fastened loops of cable to dangle, which stresses the cable at the fastening point.



**CAUTION:** Avoid bending fiber-optic cable beyond its minimum bend radius. An arc smaller than a few inches in diameter can damage the cable and cause problems that are difficult to diagnose.

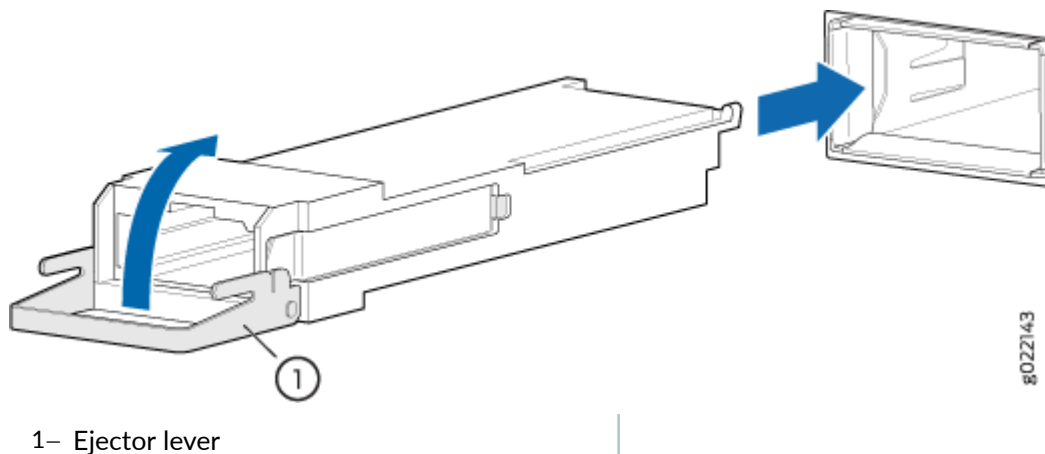
**NOTE:** When you install SFP-DD transceivers, push it hard until you hear a click sound. Use a long nose plier to pull the SFP-DD transceiver connected on the top and bottom rows of the chassis where the pull tabs face each other.

**NOTE:** Make sure to use a dust cap to cover ports that are unused.

**NOTE:** While using Finisar AOC SFP+ optical module with the QFX5130-48C switch, you may need to pull the module upwards to pull out the module smoothly from the cage.

**NOTE:** "

Figure 200: Install a Transceiver



## Disconnect a Fiber-Optic Cable

Before you disconnect a fiber-optic cable from an optical transceiver, ensure that you have taken the necessary precautions for safe handling of lasers. See [Laser and LED Safety Guidelines and Warnings](#).

Ensure that you have the following parts and tools available:

- A rubber safety cap to cover the transceiver
- A rubber safety cap to cover the fiber-optic cable connector

Juniper Networks devices have optical transceivers to which you can connect fiber-optic cables.

To disconnect a fiber-optic cable from an optical transceiver installed in the device:

1. Disable the port in which the transceiver is installed by issuing the following command:

```
[edit interfaces]
user@device# set interface-name disable
```



**LASER WARNING:** Do not look directly into a fiber-optic transceiver or into the ends of fiber-optic cables. Fiber-optic transceivers and fiber-optic cables connected to transceivers emit laser light that can damage your eyes.

2. Carefully unplug the fiber-optic cable connector from the transceiver.
3. Cover the transceiver with a rubber safety cap.



**LASER WARNING:** Do not leave a fiber-optic transceiver uncovered except when inserting or removing a cable. The rubber safety cap keeps the port clean and protects your eyes from accidental exposure to laser light.

4. Cover the fiber-optic cable connector with the rubber safety cap.

## Connect a Fiber-Optic Cable

Before you connect a fiber-optic cable to an optical transceiver installed in a device, ensure that you have taken the necessary precautions for safe handling of lasers (see [Laser and LED Safety Guidelines and Warnings](#)).

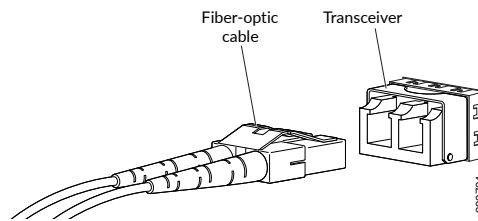
To connect a fiber-optic cable to an optical transceiver installed in a device:



**LASER WARNING:** Do not look directly into a fiber-optic transceiver or into the ends of fiber-optic cables. Fiber-optic transceivers and fiber-optic cables connected to transceivers emit laser light that can damage your eyes.

1. If the fiber-optic cable connector is covered with a rubber safety cap, remove the cap. Save the cap.
2. Remove the rubber safety cap from the optical transceiver. Save the cap.
3. Insert the cable connector into the optical transceiver (see [Figure 201 on page 330](#)).

**Figure 201: Connect a Fiber-Optic Cable to an Optical Transceiver Installed in a Device**



4. Secure the cables so that they do not support their own weight. Place excess cable out of the way in a neatly coiled loop. Placing fasteners on a loop helps cables maintain their shape.



**CAUTION:** Do not bend fiber-optic cables beyond their minimum bend radius. An arc smaller than a few inches in diameter can damage the cables and cause problems that are difficult to diagnose.

Do not let fiber-optic cables hang free from the connector. Do not allow fastened loops of cables to dangle, which stresses the cables at the fastening point.

## How to Handle Fiber-Optic Cables

Fiber-optic cables connect to optical transceivers that are installed in Juniper Networks devices.

Follow these guidelines when handling fiber-optic cables:

- When you unplug a fiber-optic cable from a transceiver, place rubber safety caps over the transceiver and on the end of the cable.

- Anchor fiber-optic cables to prevent stress on the connectors. When attaching a fiber-optic cable to a transceiver, be sure to secure the fiber-optic cable so that it does not support its own weight as it hangs to the floor. Never let a fiber-optic cable hang free from the connector.
- Avoid bending fiber-optic cables beyond their minimum bend radius. Bending fiber-optic cables into arcs smaller than a few inches in diameter can damage the cables and cause problems that are difficult to diagnose.
- Frequent plugging and unplugging of fiber-optic cables in and out of optical instruments can damage the instruments, which are expensive to repair. To prevent damage from overuse, attach a short fiber extension to the optical equipment. The short fiber extension absorbs wear and tear due to frequent plugging and unplugging, which is easier and less expensive to replace than the instruments.
- Keep fiber-optic cable connections clean. Microdeposits of oil and dust in the canal of the transceiver or cable connector can cause loss of light, reduction in signal power, and possibly intermittent problems with the optical connection.
  - To clean the transceiver canal, use an appropriate fiber-cleaning device such as RIFOCS Fiber Optic Adaptor Cleaning Wands (part number 946). Follow the instructions in the cleaning kit you use.
  - After cleaning the transceiver, make sure that the connector tip of the fiber-optic cable is clean. Use only an approved alcohol-free fiber-optic cable cleaning kit such as the Opptex Cletop-S® Fiber Cleaner. Follow the instructions in the cleaning kit you use.

## RELATED DOCUMENTATION

| *Laser and LED Safety Guidelines and Warnings*

# Removing the QFX10008

## IN THIS SECTION

- [Powering Off a QFX10000 | 332](#)
- [Removing a QFX10008 From a 4-Post Rack Using a Mechanical Lift | 334](#)
- [Manually Removing a QFX10008 from a 4-Post Rack | 336](#)

## Powering Off a QFX10000

Before you power off a QFX10000:

- Ensure that you have taken the necessary precautions to prevent electrostatic discharge (ESD) damage. See [Prevention of Electrostatic Discharge Damage](#).
- Ensure that you do not need to forward traffic through the switch.

**NOTE:** Use the following procedure to power off a QFX10000.

Ensure that you have the following parts and tools available to power off the switch:

- An ESD grounding strap
- An external management device such as a PC
- An RJ-45 to DB-9 rollover cable to connect the external management device to the console port on one of the Routing and Control Board (RCBs)

To power off a QFX10000:

1. Connect to the switch using one of the following methods:
  - Connect a management device to the console (**CON**) port on a RCB by following the instructions in ["Connect a Device to a Management Console Using an RJ-45 Connector"](#) on page 219.
  - Connect a management device to one of the two management (**MGMT**) ports on the RCB by following the instructions in ["Connect a Device to a Network for Out-of-Band Management"](#) on page 219.
2. Shut down Junos OS from the external management device by issuing the request `system halt` operational mode CLI command. This command shuts down the switch gracefully and preserves system state information. A message appears on the console, confirming that the operating system has halted.

You see the following output (or something similar, depending on the hardware being shut down) after entering the command:

```
Shutdown NOW!
System going down IMMEDIATELY

Terminated
Poweroff for hypervisor to respawn
```

```
Oct 25 10:35:05 init: event-processing (PID 1114) exited with status=1
Oct 25 10:35:05 init: packet-forwarding-engine (PID 1424) exited with status=8
.
Waiting (max 60 seconds) for system process `vnlru_mem' to stop...done
Waiting (max 60 seconds) for system process `vnlru' to stop...done
Waiting (max 60 seconds) for system process `bufdaemon' to stop...done
Waiting (max 60 seconds) for system process `syncer' to stop...
Syncing disks, vnodes remaining...0 0 0 0 done

syncing disks... All buffers synced.
Uptime: 11h0m30s
Normal shutdown (no dump device defined)
unloading fpga driver
unloading fx-scpld
Powering system off using ACPI
kvm: 28646: cpu0 disabled perfctr wrmsr: 0xc1 data 0xabcd
pci-stub 0000:01:00.2: transaction is not cleared; proceeding with reset anyway
pci-stub 0000:01:00.1: transaction is not cleared; proceeding with reset anyway
hub 1-1:1.0: over-current change on port 1
Stopping crond: [ OK ]
Stopping libvirtd daemon: [ OK ]
Shutting down ntpd: [ OK ]
Shutting down system logger: [ OK ]
Shutting down sntpc: [ OK ]
Stopping sshd: [ OK ]
Stopping vehostd: [ OK ]
Stopping watchdog: [ OK ]
Stopping xinetd: [ OK ]
Sending all processes the TERM signal... [ OK ]
Sending all processes the KILL signal... [ OK ]
Saving random seed: [ OK ]
Syncing hardware clock to system time [ OK ]
Turning off swap: [ OK ]
Unmounting file systems: [ OK ]
init: Re-executing /sbin/init
Halting system...
System halted.
```





**CAUTION:** The final output of any version of the request system halt command is the “The operating system has halted.” Wait at least 60 seconds after first seeing this message before following the instructions in Step 4 and Step 5 to power off the switch.

3. Attach the grounding strap to your bare wrist and to one of the two site ESD points on the chassis.
4. Disconnect power to the switch by performing one of the following tasks:
  - AC power supply—Set the enable switch to the OFF (O) position and gently pull out the coupler for the power cord from the faceplate.
  - DC power supply—Switch the circuit breaker on the panel board that services the DC circuit to the OFF position.
5. Remove the power source cable from the power supply faceplate:
  - AC power supply—Remove the power cord from the power supply faceplate by detaching the power cord retainer and gently pulling out the plug end of the power cord connected to the power supply faceplate.
  - DC power supply—Loosen the thumbscrews securing the DC power connector on the power source cables. Remove the power source cables from the power supply.
6. Remove any remaining cables and optics from the switch before removing it from the rack.

## Removing a QFX10008 From a 4-Post Rack Using a Mechanical Lift

Before you remove the switch using a lift:

- Ensure that the rack is stable and secured to the building.
- Ensure there is enough space to place the removed switch in its new location and along the path to the new location. See ["QFX10000 Clearance Requirements for Airflow and Hardware Maintenance" on page 158](#).
- Review ["General Safety Guidelines and Warnings" on page 369](#).
- Review the chassis lifting guidelines described in [QFX10002 Installation Safety Guidelines](#).
- Ensure that the switch has been safely powered off.



**CAUTION:** When removing more than one switch chassis from a rack, remove the switches in order from top to bottom.

Ensure that you have the following parts and tools available to remove the switch:

- A mechanical lift rated for 500 lbs. (226.8 kg)
- A Phillips (+) screwdriver, number 2 or number 3, depending on the size of your rack-mounting screws

Because of the switch's size and weight, we strongly recommend using a mechanical lift to install the QFX10008.

**NOTE:** For instructions on installing a switch without using a mechanical lift, see "[Manually Removing a QFX10008 from a 4-Post Rack](#)" on page 336.

To remove the switch using a mechanical lift (see [Figure 202 on page 336](#)):

1. Use the appropriate Phillips (+) screwdriver to remove the 24 mounting screws that attach the chassis front-mounting brackets to the rack.
2. Move the lift to the rack and position it so that its platform is centered about 0.5 in. (1.27 cm) below the bottom of the switch chassis and as close to it as possible.
3. Carefully slide the switch from the adjustable mounting brackets attached to the rack onto the lift.
4. Move the lift away from the rack and lower the lift.
5. Use the lift to transport the switch to its new location.

Figure 202: Moving the QFX10008 Using a Mechanical Lift



#### SEE ALSO

[QFX10000 Clearance Requirements for Airflow and Hardware Maintenance](#) | 158

## Manually Removing a QFX10008 from a 4-Post Rack

Before you manually remove the switch from a rack:

- Ensure that the rack is stable and secured to the building.

- Ensure there is enough space to place the removed switch in its new location and along the path to the new location. See ["QFX10000 Clearance Requirements for Airflow and Hardware Maintenance" on page 158](#).
- Review ["General Safety Guidelines and Warnings" on page 369](#).
- Review the chassis lifting guidelines described in ["Chassis and Component Lifting Guidelines" on page 375](#).
- Ensure that the switch has been safely powered off.

Ensure you have a Phillips (+) screwdriver, number 2 or number 3, depending on the size of your rack-mounting screws.

If you cannot use a mechanical lift to remove the switch (the preferred method), you can install it manually.



**CAUTION:** The chassis weighs approximately 145 lb (66 kg) with only the fan tray controllers installed. Lifting the chassis and mounting it in a rack or cabinet requires at least four people.

Make sure the chassis is empty (contains only the backplane) before you lift it.



**CAUTION:** When removing more than one switch chassis from a rack, remove the switches in order from top to bottom.

To manually remove a QFX10008 from a rack:

1. Remove all line cards, Control Boards, power supplies, fan trays, and SIBs before attempting to move the switch chassis.
  - ["Removing a QFX10000 Line Card" on page 309](#)
  - ["Removing a QFX10000 Routing and Control Board" on page 230](#)
  - ["How to Remove a QFX10000-PWR-AC Power Supply" on page 244](#)
  - ["How to Remove a QFX10000-PWR-DC Power Supply" on page 267](#)
  - ["Removing a QFX10008 Fan Tray" on page 235](#)
  - ["Removing a QFX10000 Switch Interface Board" on page 298](#)

Ensure that all of the removed components are stored in electrostatic bags.

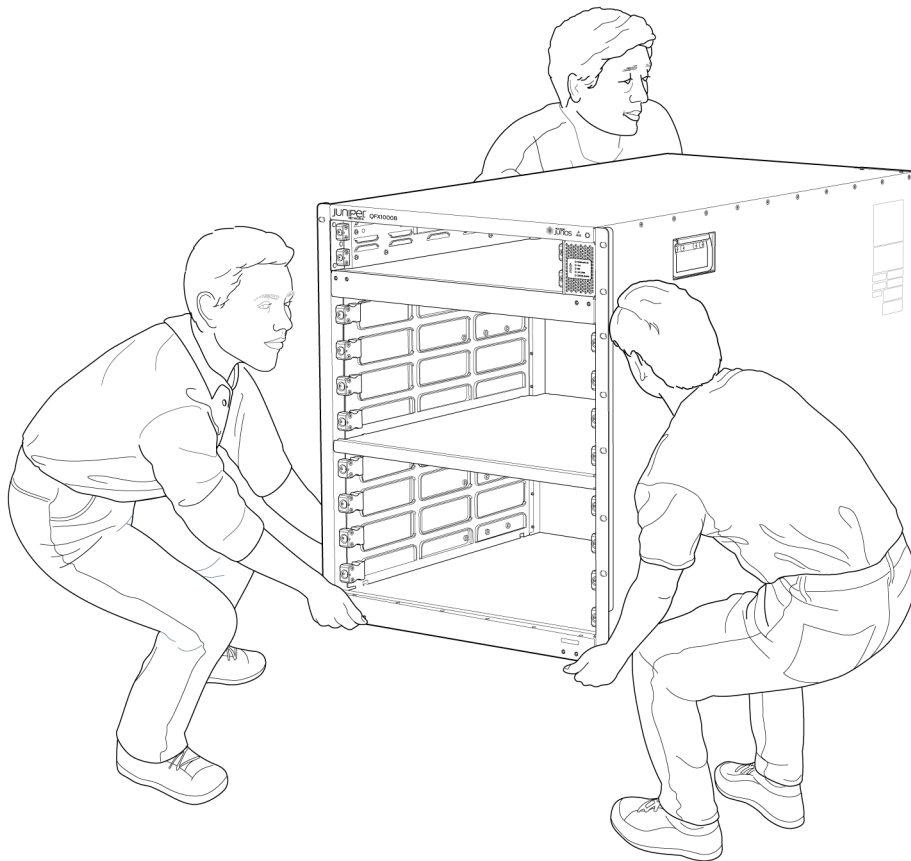
2. Use the appropriate Phillips (+) screwdriver to remove the 24 mounting screws that attach the chassis front-mounting brackets to the rack.



**WARNING:** To prevent injury, keep your back straight and lift with your legs, not your back. Do not twist your body as you lift. Balance the load evenly and be sure that your footing is firm.

3. Position one person on each side and another in the rear of the chassis. There are two handles on the side, but these handles are only meant to help guide the empty chassis out of the mounting brackets.
4. On each side, hold the bottom of the chassis and carefully lift it onto the mounting brackets on the four-post rack.
5. Carefully lift it out of the adjustable mounting brackets attached to the rack. If you have a pallet jack, move the switch onto the pallet jack. See [Figure 203 on page 338](#).

**Figure 203: Lifting the QFX10008 Without Using a Mechanical Lift**



8050605

6. Carefully move the chassis to its new location.

After moving the switch to its new location, reinstall the components in the chassis or store the components in electrostatic bags.

**SEE ALSO**

[Chassis and Component Lifting Guidelines | 375](#)

**RELATED DOCUMENTATION**

[QFX10000 AC Power System | 44](#)

[QFX10000 DC Power System | 65](#)

---

# 5

CHAPTER

## Troubleshooting

---

Troubleshooting QFX10000 Modular Chassis | 341

---

# Troubleshooting QFX10000 Modular Chassis

## IN THIS SECTION

- [QFX10000 Troubleshooting Resources Overview | 341](#)
- [QFX Series Alarm Messages Overview | 342](#)
- [Chassis Alarm Messages on QFX10008 and QFX10016 Modular Chassis Switches | 342](#)

## QFX10000 Troubleshooting Resources Overview

To troubleshoot a QFX10000 modular chassis, you use the Junos OS CLI, alarms, and LEDs on the network ports, management panel, and components.

- LEDs—When the Routing Engine detects an alarm condition, it lights the red or yellow alarm LED on the management panel as appropriate. In addition, you can also use component LEDs and network port LEDs to troubleshoot the QFX10000. For more information, see the following topics:
  - ["Status Panel" on page 25](#)
  - ["QFX10000 Routing and Control Board LEDs" on page 83](#)
  - ["QFX10000 Line Card LEDs" on page 146](#)
  - ["QFX10000 Fan Tray LEDs and Fan Tray Controller LEDs" on page 37](#)
  - ["QFX10000 AC Power Supply LEDs" on page 61](#) and ["QFX10000-PWR-DC Power Supply LEDs" on page 73](#)
- CLI—The CLI is the primary tool for controlling and troubleshooting hardware, Junos OS, routing protocols, and network connectivity. CLI commands display information from routing tables, information specific to routing protocols, and information about network connectivity derived from the ping and traceroute utilities. For information about using the CLI to troubleshoot Junos OS, see the appropriate Junos OS configuration guide.
- JTAC—If you need assistance during troubleshooting, you can contact the Juniper Networks Technical Assistance Center (JTAC) by using the Web or by telephone. If you encounter software problems, or problems with hardware components not discussed here, contact JTAC.
- Knowledge Base articles—[Knowledge Base](#).



**SEE ALSO**

| [Contact Customer Support to Obtain a Return Material Authorization](#) | 348

## QFX Series Alarm Messages Overview

When a QFX Series switch detects an alarm condition, it lights the red or yellow alarm LED on the management panel as appropriate. To view a more detailed description of the alarm cause, issue the `show chassis alarms` CLI command:

```
user@host> show chassis alarms
6 alarms currently active
Alarm time           Class Description
2018-02-07 12:12:18 PST Major FPC Management1 Ethernet Link Down
2018-02-07 12:11:54 PST Minor FPC0: LED 3:Alarm LED Read Error
2018-02-07 12:11:54 PST Minor FPC0: LED 3:Alarm LED Write Error
2018-02-07 12:11:54 PST Major FPC0: PEM 1 Not Supported
2018-02-07 12:11:54 PST Major FPC0: PEM 0 Not Supported
2018-02-07 12:11:54 PST Major FPC0: PEM 0 Not Powered
```

For Junos OS Evolved systems, `show system alarms` CLI command indicates major and minor alarms on the system. In this example from a Junos OS Evolved system, a fan tray error is shown in slot 4.

```
user@host> show system alarms
2 alarms currently active
Alarm time           Class Description
2018-11-15 11:52:22 PST Major Fan Tray 4 Failure <<<<<
2018-11-15 10:40:08 PST Minor Host 0 Disk 2 Labelled incorrectly
```

## Chassis Alarm Messages on QFX10008 and QFX10016 Modular Chassis Switches

Chassis alarms indicate a failure on the device or one of its components. Chassis alarms are preset and cannot be modified.

Chassis alarms on QFX10008 and QFX10016 modular chassis have two severity levels:

- Major (red)—Indicates a critical situation on the device that has resulted from one of the conditions described in [Table 82 on page 343](#). A red alarm condition requires immediate action.
- Minor (yellow or amber)—Indicates a noncritical condition on the device that, if left unchecked, might cause an interruption in service or degradation in performance. A yellow alarm condition requires monitoring or maintenance.

[Table 82 on page 343](#) describes the chassis alarm messages on QFX10000 modular chassis switches.

**Table 82: Chassis Component Alarm Conditions on QFX10000 Modular Models**

Chassis Component	Alarm Condition	Alarm Severity	Remedy
<b>Control board</b>	A Control board has failed.	Major (red)	Replace the failed Control board.
	A Control board has been removed.	Minor (yellow)	Install a Control board in the empty slot.
<b>Line Cards</b>	A line card is offline.	Minor (yellow)	Check the line card. Remove and reinstall the line card. If this fails, replace the failed card.
	A line card has failed.	Major (red)	Replace the failed line card.
	A line card has been removed.	Major (red)	Install a line card in the empty slot.
<b>Fan trays</b>	A fan tray has been removed from the chassis.	Major (red)	Install the missing fan tray.
	One fan in the chassis is not spinning or is spinning below required speed.	Major (red)	Replace the fan tray.
	A fan is not receiving power from the fan tray controller.	Major (red)	Check and replace the failed fan tray controller if required.
<b>Fan Tray Controller</b>	A fan tray controller has failed.	Minor (yellow)	Check and replace the failed fan tray controller if required.

Table 82: Chassis Component Alarm Conditions on QFX10000 Modular Models (Continued)

Chassis Component	Alarm Condition	Alarm Severity	Remedy
	One of the fan tray controller in the chassis is not receiving enough power.	Major (red)	Check the power supply.
<b>Switch Interface Boards (SIBs)</b>	One of the SIB has failed.	Minor (yellow)	Check the below: <ul style="list-style-type: none"> <li>The SIB is not receiving power.</li> <li>The fan tray controller is having a power problem.</li> </ul>
<b>SATA SSD slot</b>	The SSD has failed or removed.	Major (red)	Install the SSD.
<b>Ethernet</b>	The Ethernet management interface on the Control board is down.	Minor (yellow)	<ul style="list-style-type: none"> <li>Check the interface cable connection.</li> <li>Reboot the system.</li> <li>If the alarm recurs, open a support case using the Case Manager link at <a href="https://www.juniper.net/support/">https://www.juniper.net/support/</a> or call 1-888-314-5822 (toll free, US &amp; Canada) or 1-408-745-9500 (from outside the United States).</li> </ul>
<b>Hot swapping</b>	Too many hot-swap interrupts are occurring.	Major (red)	Replace the failed components.
<b>Power supplies</b>	A power supply has been removed from the chassis.	Minor (yellow)	Install a power supply in the empty slot.
	A power supply has a high temperature.	Major (red)	Replace the failed power supply.
	A power supply input has failed.	Major (red)	Check power supply input connection and the power cord.

**Table 82: Chassis Component Alarm Conditions on QFX10000 Modular Models (Continued)**

Chassis Component	Alarm Condition	Alarm Severity	Remedy
	A power supply output has failed.	Major (red)	Check power supply output connection.
	A power supply has failed.	Major (red)	Replace the failed power supply.
	AC and DC power supplies are installed.	Major (red)	Do not mix AC and DC power supplies.
	Inadequate number of power supplies.	Major (red)	Install an additional power supply.
<b>Temperature</b>	The chassis temperature has exceeded 131° F (55° C), the fans have been turned on to full speed, and one or more fans have failed.	Minor (yellow)	<ul style="list-style-type: none"> <li>• Check room temperature.</li> <li>• Check airflow.</li> <li>• Replace the fan tray.</li> </ul>
	The chassis temperature has exceeded 149° F (65° C), and the fans have been turned on to full speed.	Minor (yellow)	<ul style="list-style-type: none"> <li>• Check room temperature.</li> <li>• Check airflow.</li> <li>• Check the fans.</li> </ul>
	The chassis temperature has exceeded 149° F (65° C), and a fan has failed. If this condition persists for more than 4 minutes, the switch will shut down.	Major (red)	<ul style="list-style-type: none"> <li>• Check room temperature.</li> <li>• Check airflow.</li> <li>• Check the fan.</li> </ul>
	Chassis temperature has exceeded 167° F (75° C). If this condition persists for more than 4 minutes, the switch will shut down.	Major (red)	<ul style="list-style-type: none"> <li>• Check room temperature.</li> <li>• Check airflow.</li> <li>• Check fan.</li> </ul>

**Table 82: Chassis Component Alarm Conditions on QFX10000 Modular Models (Continued)**

Chassis Component	Alarm Condition	Alarm Severity	Remedy
	The temperature sensor has failed.	Major (red)	Open a support case using the Case Manager link at <a href="https://www.juniper.net/support/">https://www.juniper.net/support/</a> or call 1-888-314-5822 (toll free, US & Canada) or 1-408-745-9500 (from outside the United States).

**SEE ALSO**

*Configuring Junos OS to Determine Conditions That Trigger Alarms on Different Interface Types*  
*alarm*

**RELATED DOCUMENTATION**

*Contact Customer Support to Obtain Return Material Authorization*

# 6

CHAPTER

## Contacting Customer Support and Returning the Chassis or Components

---

[Contact Customer Support to Obtain a Return Material Authorization | 348](#)

[Returning the QFX10000 Chassis or Component | 349](#)

---

# Contact Customer Support to Obtain a Return Material Authorization

If you need to return a device or hardware component to Juniper Networks for repair or replacement, obtain a Return Material Authorization (RMA) number from Juniper Networks Technical Assistance Center (JTAC). You must obtain an RMA number before you attempt to return the component.

After locating the serial number of the device or hardware component you want to return, open a service request with the Juniper Networks Technical Assistance Center (JTAC) on the Web or by telephone.

Before you request an RMA number from JTAC, be prepared to provide the following information:

- Your existing service request number, if you have one
- Serial number of the component
- Your name, organization name, telephone number, fax number, and shipping address
- Details of the failure or problem
- Type of activity being performed on the device when the problem occurred
- Configuration data displayed by one or more `show` commands

You can contact JTAC 24 hours a day, seven days a week on the Web or by telephone:

- Service Request Manager: <https://support.juniper.net/support>
- Telephone: +1-888-314-JTAC (+1-888-314-5822), toll free in U.S., Canada, and Mexico

**NOTE:** For international or direct-dial options in countries without toll free numbers, see <https://support.juniper.net/support>.

If you are contacting JTAC by telephone, enter your 12-digit service request number followed by the pound (#) key for an existing case, or press the star (\*) key to be routed to the next available support engineer.

The support representative validates your request and issues an RMA number for return of the component.

# Returning the QFX10000 Chassis or Component

## IN THIS SECTION

- How to Return a Hardware Component to Juniper Networks, Inc. | 349
- Locating the Serial Number on a QFX10000 Switch or Component | 350
- Packing a QFX10000 or Component for Shipping | 360

## How to Return a Hardware Component to Juniper Networks, Inc.

If a hardware component fails, please contact Juniper Networks, Inc. to obtain a Return Material Authorization (RMA) number. This number is used to track the returned material at the factory and to return repaired or new components to the customer as needed.

**NOTE:** Do not return any component to Juniper Networks, Inc. unless you have first obtained an RMA number. Juniper Networks, Inc. reserves the right to refuse shipments that do not have an RMA. Refused shipments are returned to the customer by collect freight.

For more information about return and repair policies, see the customer support webpage at <https://support.juniper.net/support/>.

For product problems or technical support issues, contact the Juniper Networks Technical Assistance Center (JTAC) by using the Service Request Manager link at <https://support.juniper.net/support/> or at 1-888-314-JTAC (within the United States) or 1-408-745-9500 (from outside the United States).

To return a defective hardware component:

1. Determine the part number and serial number of the defective component.
2. Obtain an RMA number from the Juniper Networks Technical Assistance Center (JTAC). You can send e-mail or telephone as described above.
3. Provide the following information in your e-mail message or during the telephone call:
  - Part number and serial number of component
  - Your name, organization name, telephone number, and fax number
  - Description of the failure



4. The support representative validates your request and issues an RMA number for return of the component.
5. Pack the component for shipment.

## Locating the Serial Number on a QFX10000 Switch or Component

### IN THIS SECTION

- [Listing the Chassis and Component Details Using the CLI | 351](#)
- [Locating the Chassis Serial Number ID Label on a QFX10008 or QFX10016 | 352](#)
- [Locating the Serial Number ID Labels on QFX10000 Power Supplies | 354](#)
- [Locating the Serial Number ID Labels on QFX10000 Fan Trays and Fan Tray Controllers | 357](#)
- [Locating the Serial Number ID Labels on QFX10000 Routing Control Boards | 358](#)
- [Locating the Serial Number ID Labels on a QFX10000 Line Card | 358](#)
- [Locating the Serial Number ID Labels on a QFX10000 Switch Interface Board \(SIB\) | 359](#)
- [Locating the Serial Number ID Label on a QFX10000 SATA SSD | 359](#)

If you are returning a switch or component to Juniper Networks for repair or replacement, you must locate the serial number of the switch or component. You must provide the serial number to the Juniper Networks Technical Assistance Center (JTAC) when you contact them to obtain a Return Materials Authorization (RMA). See [Contact Customer Support to Obtain Return Material Authorization](#).

If the switch is operational and you can access the command-line interface (CLI), you can list serial numbers for the switch and for some components with a CLI command. If you do not have access to the CLI or if the serial number for the component does not appear in the command output, you can locate the serial number ID label on the switch or component.

**NOTE:** If you want to find the serial number ID label on a component, you need to remove the component from the switch chassis, for which you must have the required parts and tools available.

## Listing the Chassis and Component Details Using the CLI

To list the QFX10008 or QFX10016 chassis and the components and their serial numbers, use the `show chassis hardware` CLI operational mode command.

```

user@device> show chassis hardware
Hardware inventory:
Item           Version  Part number  Serial number  Description
Chassis                               BLANK          QFX10008
Midplane       REV 03   750-054097  ACAM4920      QFX10008 Midplane
Routing Engine 0          BUILTIN      BUILTIN       Routing Engine
Routing Engine 1          BUILTIN      BUILTIN       Routing Engine
CB 0           REV 18   750-052688  ACAM7712      Control Board
CB 1           REV 18   750-052688  ACAM7720      Control Board
FPC 0          REV 16   750-051354  ACAM8331      ULC-36Q-12Q28
  CPU                               BUILTIN        BUILTIN       FPC CPU
  PIC 0                               BUILTIN        BUILTIN       36X40G
    Xcvr 0       REV 01   740-032986  QC260842      QSFP+40G-SR4
    Xcvr 1       REV 01   740-032986  QE147578      QSFP+40G-SR4
    Xcvr 2       REV 01   740-032986  QE119008      QSFP+40G-SR4
    Xcvr 3       REV 01   740-032986  QD503969      QSFP+40G-SR4
    Xcvr 4       REV 01   740-032986  QA470217      QSFP+40G-SR4
    Xcvr 5       REV 01   740-032986  QC320521      QSFP+40G-SR4
    Xcvr 6       REV 01   740-046565  QC470283      QSFP+40G-SR4
    Xcvr 7       REV 01   740-032986  QC320611      QSFP+40G-SR4
    Xcvr 11      REV      740-038624  APF14260038R37  QSFP+40G-CU3M
    Xcvr 12      REV      740-038624  APF14260030135  QSFP+40G-CU3M
    Xcvr 13      REV 01   740-032986  QB130489      QSFP+40G-SR4
    Xcvr 14      REV 01   740-032986  QD503964      QSFP+40G-SR4
  Xcvr 16      REV 01   740-032986  QA470031      QSFP+40G-SR4
    Xcvr 17      REV 01   740-032986  QE118996      QSFP+40G-SR4
    Xcvr 19      REV 01   740-032986  QE141901      QSFP+40G-SR4
    Xcvr 22      REV 01   740-032986  QA390341      QSFP+40G-SR4
    Xcvr 23      REV 01   740-032986  QD503968      QSFP+40G-SR4
    Xcvr 28      REV      740-038624  APF15230034PKT  QSFP+40G-CU3M
    Xcvr 29      REV 01   740-032986  QD503958      QSFP+40G-SR4
    Xcvr 31      REV 01   740-032986  QE118997      QSFP+40G-SR4
    Xcvr 33      REV 01   740-032986  QD503965      QSFP+40G-SR4
FPC 4          REV 16   750-051354  ACAM8342      ULC-36Q-12Q28
  CPU                               BUILTIN        BUILTIN       FPC CPU
  PIC 0                               BUILTIN        BUILTIN       36X40G
    Xcvr 1       REV 01   740-032986  QC320517      QSFP+40G-SR4

```

```

Xcvr 2      REV 01  740-032986  QD475008      QSFP+40G-SR4
Xcvr 3      REV      740-038624  APF14260038R44  QSFP+40G-CU3M
Xcvr 4      REV 01  740-032986  QD372520      QSFP+40G-SR4
Xcvr 6      REV 01  740-032986  QE119029      QSFP+40G-SR4
Xcvr 13     REV 01  740-032986  QC320507      QSFP+40G-SR4
Xcvr 14     REV 01  740-032986  QD420798      QSFP+40G-SR4
Xcvr 22     REV 01  740-032986  QD512208      QSFP+40G-SR4
Xcvr 23     REV 01  740-032986  QC320520      QSFP+40G-SR4
Xcvr 27     REV 01  740-032986  QD472868      QSFP+40G-SR4
Xcvr 30     REV 01  740-032986  QD503966      QSFP+40G-SR4
Xcvr 34     REV 01  740-032986  QD420760      QSFP+40G-SR4
FPC 6      REV 16  750-051357  ACAM7581      ULC-30Q28
CPU
PIC 0
Xcvr 0      REV 01  740-061405  1ACQ103602H   100GBASE-SR4
Xcvr 1      REV 01  740-061405  1ACQ103601M   100GBASE-SR4
Xcvr 4      REV01  740-061001  LE01528003N   QSFP28-100G-CU3M
Xcvr 7      REV01  740-061001  LE015280045   QSFP28-100G-CU3M
Xcvr 15     REV01  740-061001  LE01528004J   QSFP28-100G-CU3M
Xcvr 23     REV01  740-061001  LE015280053   QSFP28-100G-CU3M
FPD Board
Power Supply 0  REV 01  740-049388  1EDL44300CY   AC 12V Power Supply
Power Supply 1  REV 01  740-049388  1EDL44300BW   AC 12V Power Supply
Power Supply 2  REV 01  740-049388  1EDL44300CC   AC 12V Power Supply
FTC 0
FTC 1      REV 08  750-050108  ACAM9108      QFX10000 FTC
Fan Tray 0    REV 03  760-054372  ACAM3620      QFX10008 FHB
Fan Tray 1    REV 03  760-054372  ACAM3613      QFX10008 FHB
SIB 0      REV 10  750-050058  ACAM8348      QFX10008 SIB
SIB 1      REV 05  750-050058  ACAM3938      QFX10008 SIB
SIB 2      REV 05  750-050058  ACAM3940      QFX10008 SIB
SIB 3      REV 05  750-050058  ACAM3967      QFX10008 SIB
SIB 4      REV 05  750-050058  ACAM3927      QFX10008 SIB
SIB 5      REV 05  750-050058  ACAM3953      QFX10008 SIB

user@device>

```

## Locating the Chassis Serial Number ID Label on a QFX10008 or QFX10016

The serial number ID label is located on a label on the right side of the chassis. See [Figure 204 on page 353](#) for the location on a QFX10008 and [Figure 205 on page 354](#) for the QFX10016.

Figure 204: QFX10008 Serial Number Label

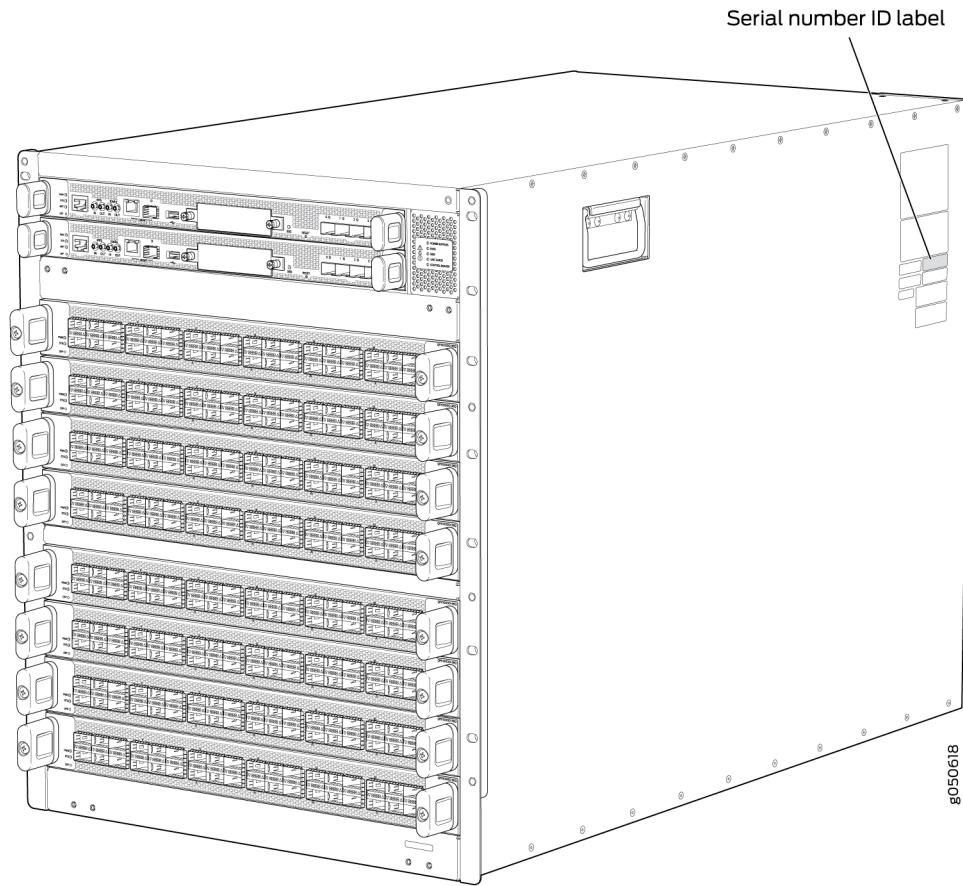
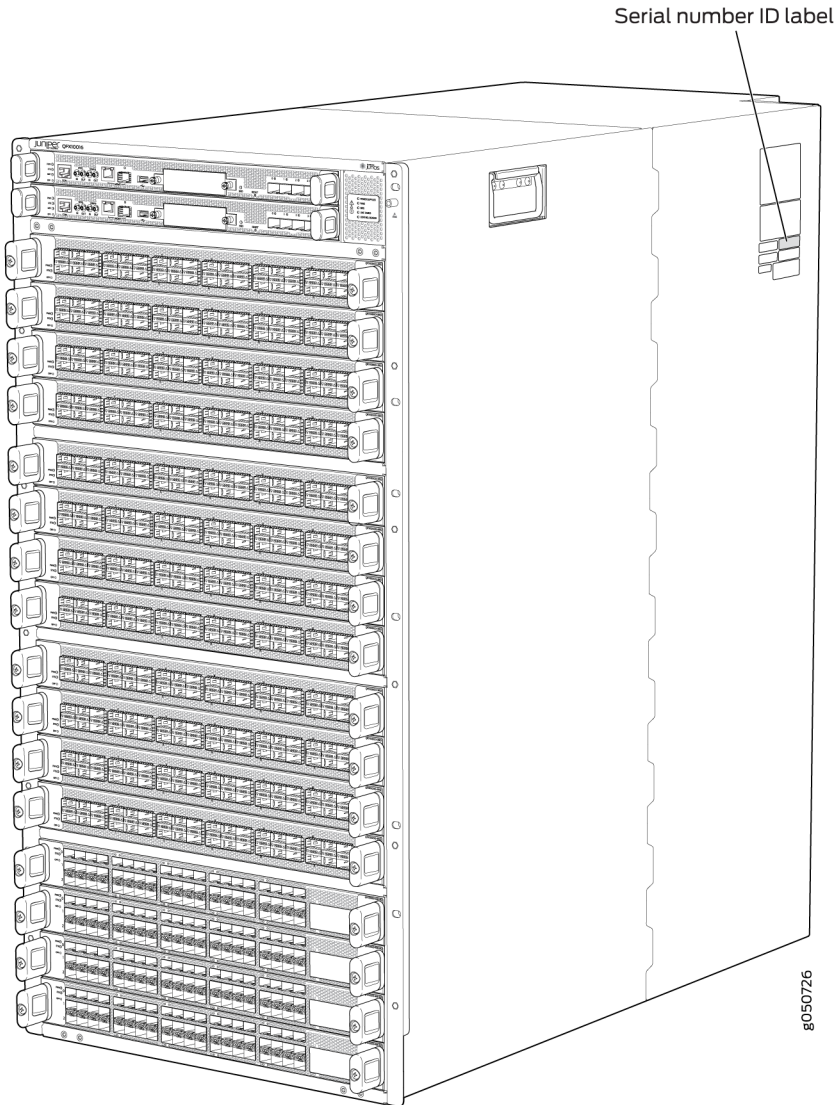


Figure 205: QFX10016 Serial Number Label

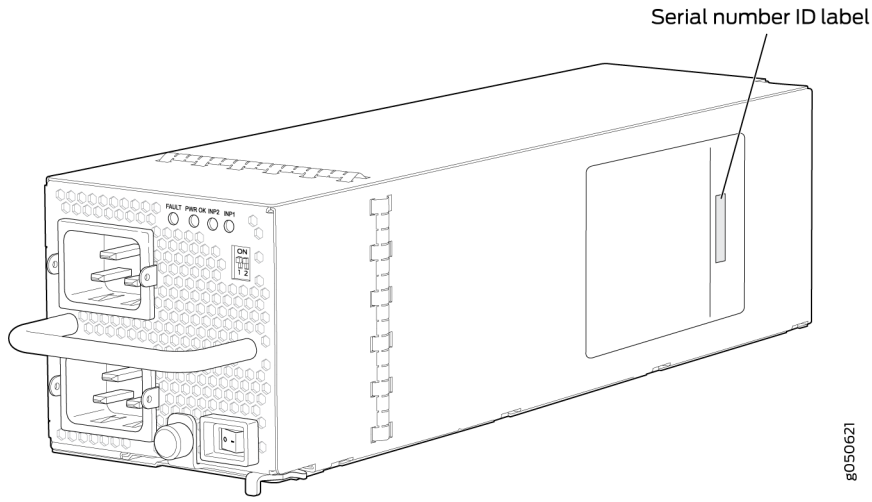


### Locating the Serial Number ID Labels on QFX10000 Power Supplies

The power supplies installed in a QFX10000 are field-replaceable units (FRUs). For each FRU, you must remove the FRU from the switch chassis to see the FRU serial number ID label.

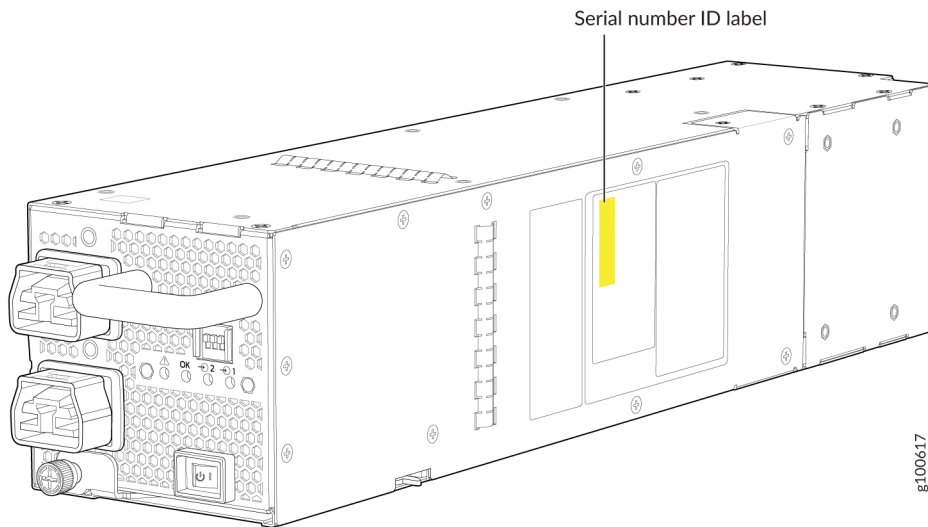
- QFX10000-PWR-AC power supply—The serial number ID label is on the right side of the power supply. See [Figure 206 on page 355](#).

**Figure 206: QFX10000 PWR-AC Power Supply Serial Number Location**



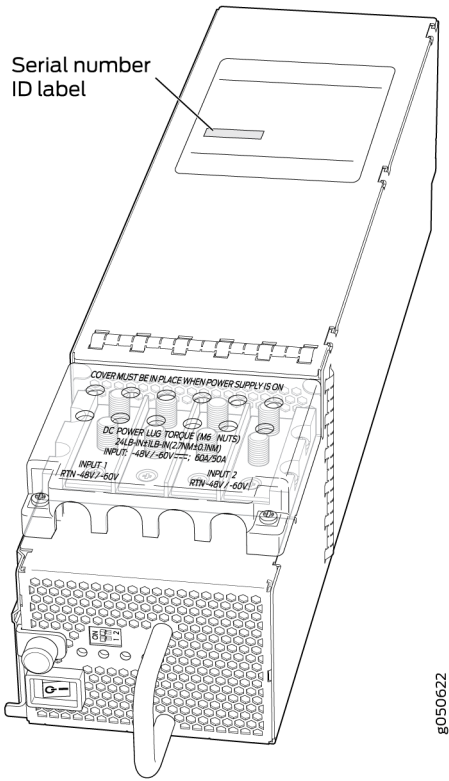
- JNP10K-PWR-AC2 power supply—The serial ID label is on the right side of the power supply. See [Figure 207 on page 355](#).

**Figure 207: JNP10K-PWR-AC2 Power Supply Serial Number Location**



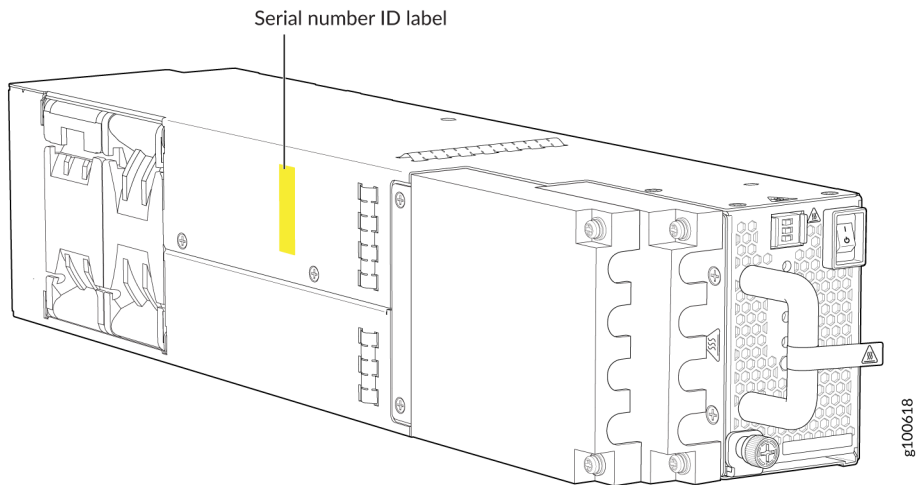
- QFX10000-PWR-DC power supply—The serial number ID label is on the left side of the power supply. See [Figure 208 on page 356](#).

Figure 208: QFX10000 PWR-DC Power Supply Serial Number Location



- JNP10K-PWR-DC2 power supply—The serial number ID label is on the left side of the power supply. See [Figure 209 on page 356](#).

Figure 209: JNP10K-PWR-DC2 Power Supply Serial Number Location

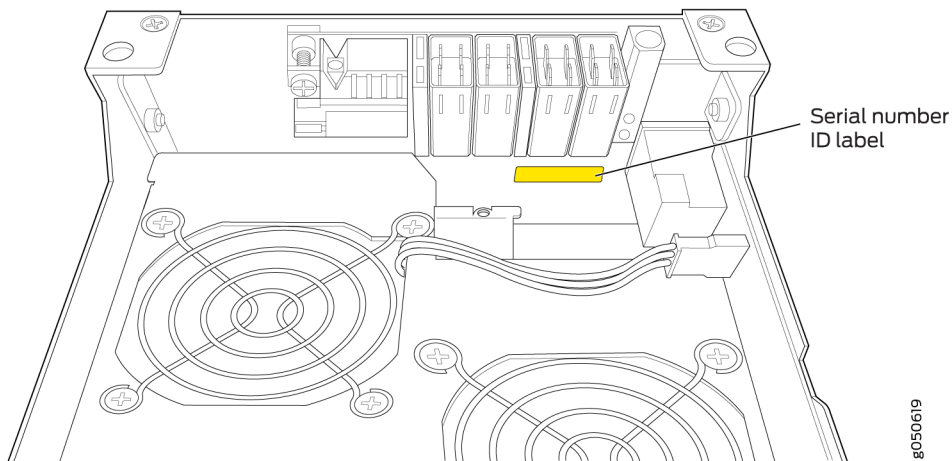


## Locating the Serial Number ID Labels on QFX10000 Fan Trays and Fan Tray Controllers

The two fan trays and their associated fan tray controllers installed in a QFX10000 are field-replaceable units (FRUs). For each FRU, you must remove the FRU from the switch chassis to see the FRU serial number ID label.

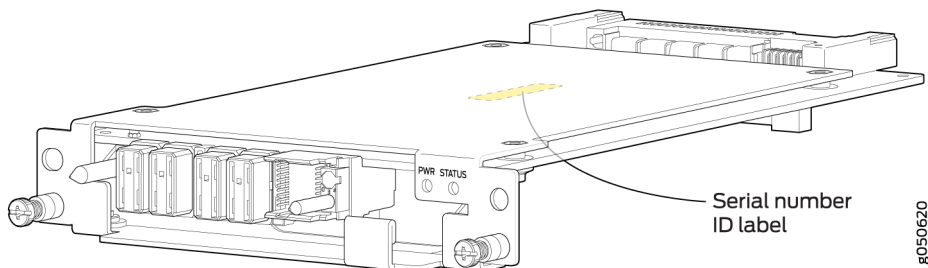
- Fan tray—The serial number ID label is located on the inside of the fan tray at the base of the fan tray Control Board. See [Figure 210 on page 357](#).

**Figure 210: QFX10000 Fan Tray Serial Number Location**



- Fan tray controller—The serial number ID label is located on the top of the fan tray controller. See [Figure 211 on page 357](#).

**Figure 211: QFX10000 Fan Tray Controller Serial Number Location**

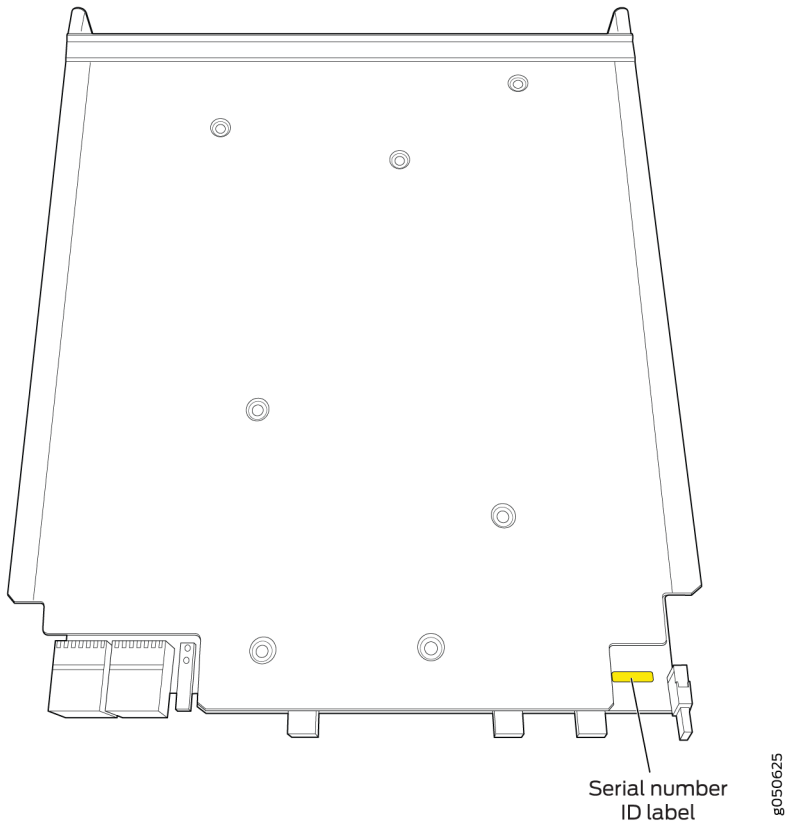




## Locating the Serial Number ID Labels on QFX10000 Routing Control Boards

The serial number ID label for a Routing Control Board is located on the connector end of the unit. See [Figure 212 on page 358](#).

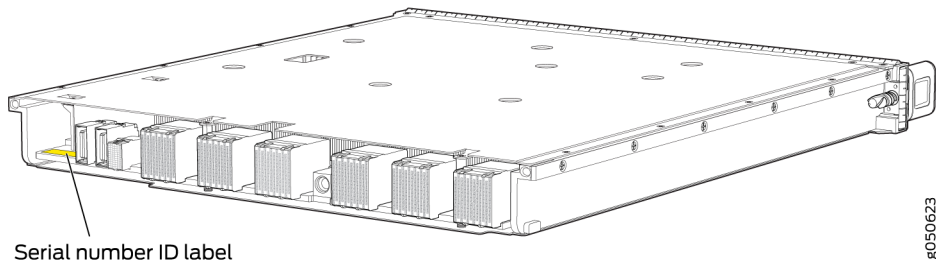
**Figure 212: QFX10000 Control Board Serial Number Location**



## Locating the Serial Number ID Labels on a QFX10000 Line Card

The serial number ID label for a line card is located on the connector end of the card. See [Figure 213 on page 359](#).

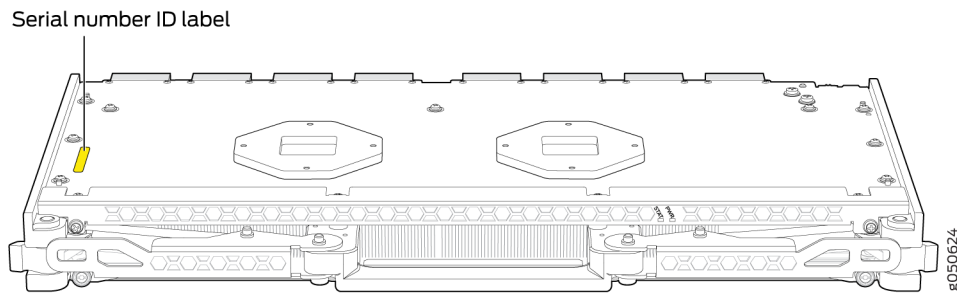
**Figure 213: QFX10000 Line Card Serial Number Location**



### Locating the Serial Number ID Labels on a QFX10000 Switch Interface Board (SIB)

The serial number ID label for a SIB is located on the PC board. See [Figure 214 on page 359](#).

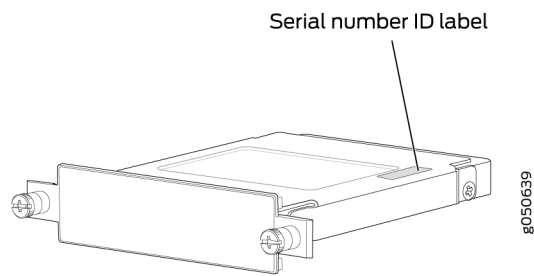
**Figure 214: QFX10000 SIB Serial Number Location**



### Locating the Serial Number ID Label on a QFX10000 SATA SSD

The serial number for a SATA SSD is located on top of the drive. See [Figure 215 on page 359](#).

**Figure 215: QFX10000 SATA SSD Serial Number Location**



## Packing a QFX10000 or Component for Shipping

### IN THIS SECTION

- [Packing a QFX10000 Switch Chassis for Shipping | 360](#)
- [Packing QFX10000 Switch Components for Shipping | 365](#)

Follow this procedure if you are returning a QFX10000 chassis or component to Juniper Networks for repair or replacement.

Before you pack a QFX10000 or component:

- Ensure that you have taken the necessary precautions to prevent electrostatic discharge (ESD) damage. See [Prevention of Electrostatic Discharge Damage](#).
- Pack your chassis or component using one of these materials:
  - Use the packing material from the replacement chassis or component
  - Retrieve the original shipping carton and packing materials

Contact your JTAC representative if you do not have these materials, to learn about approved packing materials. See [Contact Customer Support to Obtain Return Material Authorization](#).

Ensure that you have the following parts and tools available:

- ESD grounding strap.
- Electrostatic bag, one for each component.
- If you are returning the chassis:
  - A 13/32-in. or 10-mm open-end or socket wrench to install the bracket bolts on the chassis and shipping pallet
  - An appropriate screwdriver for the mounting screws used on your rack.

This topic covers:

### Packing a QFX10000 Switch Chassis for Shipping

The QFX10000 is shipped in a cardboard box that has a two-layer wooden pallet base with foam cushioning between the layers. The switch chassis is bolted to the pallet base with four pallet fasteners,

two on each side of the chassis. See Figure 13 for the stacking configuration of the QFX10008 and Figure 14 for the QFX10016.

**Figure 216: Stacking Configuration for Packing the QFX10008 Chassis**

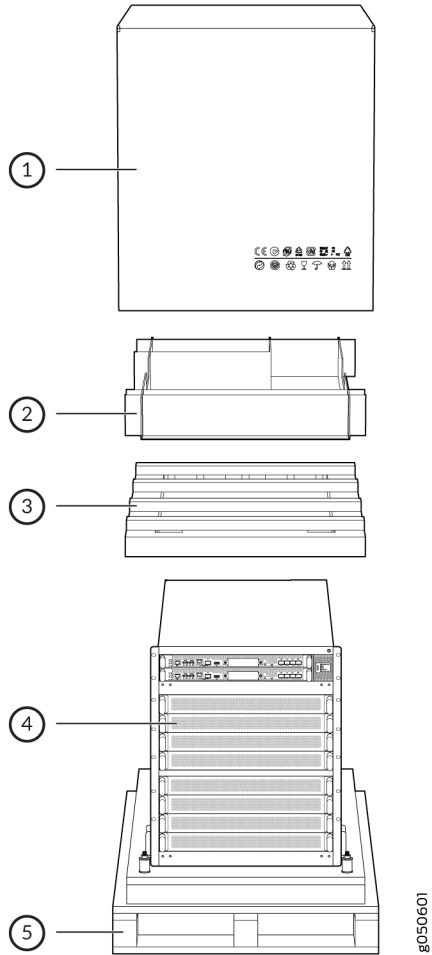
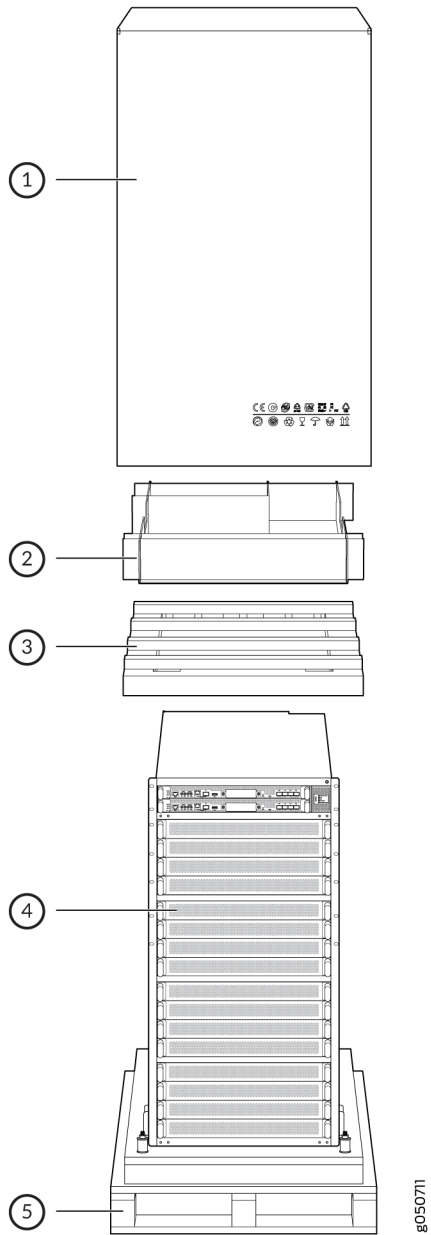


Figure 217: Stacking Configuration for Packing the QFX10016 Chassis



To pack a QFX10000 for shipping:

1. Power down the chassis and remove the power cables. See ["Powering Off a QFX10000" on page 332](#).
2. Remove the cables that connect the QFX10000 to all external devices.
3. Remove all line cards and pack them in their original shipping containers.
4. Install cover panels over blank slots.

Leave components that came installed in the chassis in the chassis, such as the Control Boards or power supplies.

5. Move the wooden pallet and packing material to a staging area as close to the switch as possible. Make sure there is enough space to move the chassis from the rack to the wooden pallet.
6. Position a mechanical lift under the device. If a mechanical lift is not available, have three people support the weight of the switch while another person uses the screwdriver to remove the front mounting screws that attach the chassis mounting brackets to the rack. For QFX10008 removal, see ["Removing a QFX10008 From a 4-Post Rack Using a Mechanical Lift" on page 334](#) or ["Manually Removing a QFX10008 from a 4-Post Rack" on page 336](#). For QFX10016 removal, see ["Removing a QFX10016 From a 4-Post Rack Using a Mechanical Lift"](#).
7. Remove the switch from the rack (see ["Installation Instructions Warning"](#)) and place the switch on the shipping pallet. Position the switch on the pallet so that the front of the switch is facing the silkscreened "front" mark on the pallet. The pallet also has crop marks to guide you in positioning the chassis.
8. Use the 13/32-in. or 10-mm open-end or socket wrench to install the four sets of brackets and bolts that secure the chassis to the wooden pallet.
9. Slide the plastic cover over the switch chassis. The plastic cover is part of the switch's original packing materials.
10. Place the packing foam on top of and around the switch.
11. Place the power cords in the box.
12. Remove the adjustable mounting brackets from the rack and place them and their connecting screws in the accessory box.
13. If you are returning accessories or FRUs with the switch, pack them as instructed in ["Packing QFX10000 Switch Components for Shipping" on page 365](#).
14. Verify that all accessories are present. See ["Comparing the QFX10000 Order to the Packing List" on page 191](#).
15. Slide the cardboard box over the chassis, making sure that the arrows on the box point up and the pallet fasteners to secure the cardboard box to the wooden pallet are near the bottom.
16. Attach the cardboard box to the wooden pallet by screwing two screws into each of the four pallet fasteners. See Figure 15 and Figure 16.

Figure 218: Attaching the QFX10008 to the Pallet

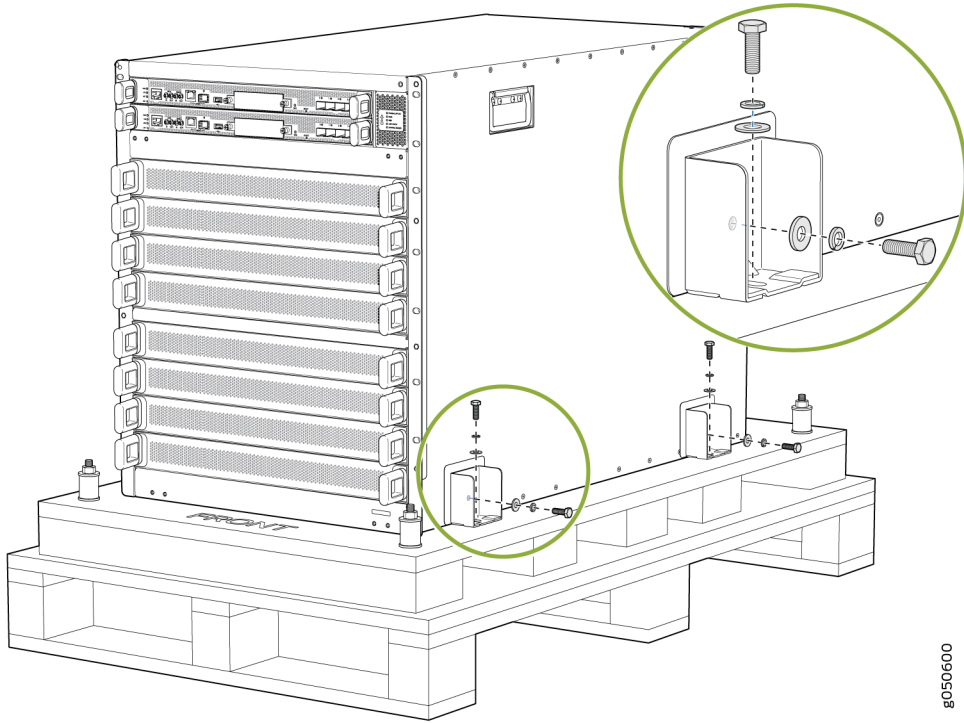
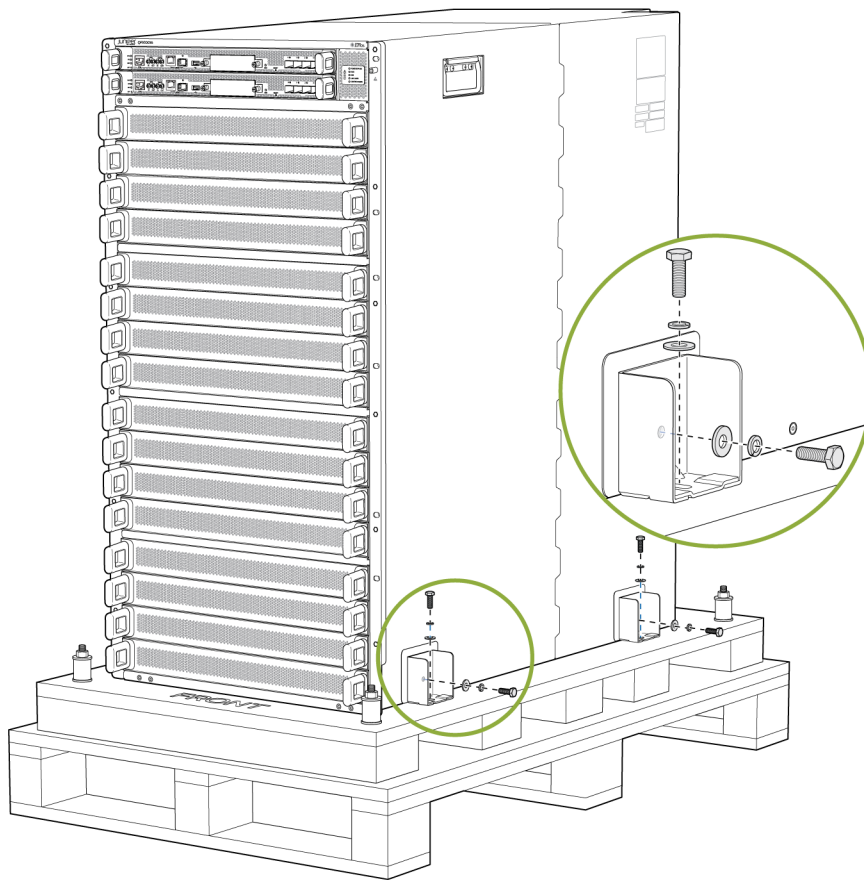


Figure 219: Attaching the QFX10016 to the Pallet



8050712

17. Write the RMA number on the exterior of the box to ensure proper tracking.

### Packing QFX10000 Switch Components for Shipping

Before you begin packing a switch component, ensure that you have the following parts and tools available:

- Antistatic bag, one for each component
- Electrostatic discharge (ESD) grounding strap



**CAUTION:** Do not stack switch components. Return individual components in separate boxes if they do not fit together on one level in the shipping box.

To pack and ship QFX10000 components:

1. Place individual FRUs in antistatic bags.



2. Use the original packing materials if they are available. If the original packing materials are not available, ensure the component is adequately packed to prevent damage during transit. The packing material you use must be able to support the weight of the component.
3. Ensure that the components are adequately protected with packing materials and packed so that the pieces are prevented from moving around inside the carton.
4. Close the top of the cardboard shipping box and seal it with packing tape.
5. Write the RMA number on the exterior of the box to ensure proper tracking.

## RELATED DOCUMENTATION

[QFX10008 System Overview | 2](#)

---

*QFX10016 System Overview*

---

*Contact Customer Support to Obtain Return Material Authorization*

# 7

CHAPTER

## Safety and Compliance Information

---

- General Safety Guidelines and Warnings | 369
- Definitions of Safety Warning Levels | 370
- Qualified Personnel Warning | 372
- Warning Statement for Norway and Sweden | 372
- Fire Safety Requirements | 373
- Installation Instructions Warning | 374
- Chassis and Component Lifting Guidelines | 375
- Restricted Access Warning | 375
- Ramp Warning | 377
- Rack-Mounting and Cabinet-Mounting Warnings | 377
- Grounded Equipment Warning | 381
- Radiation from Open Port Apertures Warning | 382
- Laser and LED Safety Guidelines and Warnings for the QFX Series | 383
- Maintenance and Operational Safety Guidelines and Warnings | 386
- General Electrical Safety Guidelines and Warnings | 392
- Action to Take After an Electrical Accident | 394
- Prevention of Electrostatic Discharge Damage | 394
- AC Power Electrical Safety Guidelines | 396
- AC Power Disconnection Warning | 397
- DC Power Electrical Safety Guidelines | 398

DC Power Disconnection Warning | 399

DC Power Grounding Requirements and Warning | 400

DC Power Wiring Terminations Warning | 401

Multiple Power Supplies Disconnection Warning | 403

TN Power Warning | 403

Agency Approvals for the QFX Series | 404

Compliance Statements for EMC Requirements for the QFX Series | 406

QFX Series Compliance Statements for NEBS | 410

Compliance Statements for Environmental Requirements | 411

---

# General Safety Guidelines and Warnings

The following guidelines help ensure your safety and protect the device from damage. The list of guidelines might not address all potentially hazardous situations in your working environment, so be alert and exercise good judgment at all times.

- Perform only the procedures explicitly described in the hardware documentation for this device. Make sure that only authorized service personnel perform other system services.
- Keep the area around the device clear and free from dust before, during, and after installation.
- Keep tools away from areas where people could trip over them while walking.
- Do not wear loose clothing or jewelry, such as rings, bracelets, or chains, which could become caught in the device.
- Wear safety glasses if you are working under any conditions that could be hazardous to your eyes.
- Do not perform any actions that create a potential hazard to people or make the equipment unsafe.
- Never attempt to lift an object that is too heavy for one person to handle.
- Never install or manipulate wiring during electrical storms.
- Never install electrical jacks in wet locations unless the jacks are specifically designed for wet environments.
- Operate the device only when it is properly grounded.
- Follow the instructions in this guide to properly ground the device to earth.
- Replace fuses only with fuses of the same type and rating.
- Do not open or remove chassis covers or sheet-metal parts unless instructions are provided in the hardware documentation for this device. Such an action could cause severe electrical shock.
- Do not push or force any objects through any opening in the chassis frame. Such an action could result in electrical shock or fire.
- Avoid spilling liquid onto the chassis or onto any device component. Such an action could cause electrical shock or damage the device.
- Avoid touching uninsulated electrical wires or terminals that have not been disconnected from their power source. Such an action could cause electrical shock.

- Some parts of the chassis, including AC and DC power supply surfaces, power supply unit handles, SFB card handles, and fan tray handles might become hot. The following label provides the warning for hot surfaces on the chassis:



- Always ensure that all modules, power supplies, and cover panels are fully inserted and that the installation screws are fully tightened.

## Definitions of Safety Warning Levels

The documentation uses the following levels of safety warnings (there are two *Warning* formats):

**NOTE:** You might find this information helpful in a particular situation, or you might overlook this important information if it was not highlighted in a Note.



**CAUTION:** You need to observe the specified guidelines to prevent minor injury or discomfort to you or severe damage to the device.

**Attention** Veillez à respecter les consignes indiquées pour éviter toute incommodité ou blessure légère, voire des dégâts graves pour l'appareil.



**LASER WARNING:** This symbol alerts you to the risk of personal injury from a laser.

**Avertissement** Ce symbole signale un risque de blessure provoquée par rayon laser.



**WARNING:** This symbol means danger. You are in a situation that could cause bodily injury. Before you work on any equipment, be aware of the hazards involved with electrical circuitry, and familiarize yourself with standard practices for preventing accidents.

**Waarschuwing** Dit waarschuwingssymbool betekent gevaar. U verkeert in een situatie die lichamelijk letsel kan veroorzaken. Voordat u aan enige apparatuur gaat werken, dient u zich bewust te zijn van de bij elektrische schakelingen betrokken risico's en dient u op de hoogte te zijn van standaard maatregelen om ongelukken te voorkomen.

**Varoitus** Tämä varoitusmerkki merkitsee vaaraa. Olet tilanteessa, joka voi johtaa ruumiinvammaan. Ennen kuin työskentelet minkään laitteiston parissa, ota selvää sähkökytkentöihin liittyvistä vaaroista ja tavanomaisista onnettomuuksien ehkäisykeinoista.

**Avertissement** Ce symbole d'avertissement indique un danger. Vous vous trouvez dans une situation pouvant causer des blessures ou des dommages corporels. Avant de travailler sur un équipement, soyez conscient des dangers posés par les circuits électriques et familiarisez-vous avec les procédures couramment utilisées pour éviter les accidents.

**Warnung** Dieses Warnsymbol bedeutet Gefahr. Sie befinden sich in einer Situation, die zu einer Körperverletzung führen könnte. Bevor Sie mit der Arbeit an irgendeinem Gerät beginnen, seien Sie sich der mit elektrischen Stromkreisen verbundenen Gefahren und der Standardpraktiken zur Vermeidung von Unfällen bewußt.

**Avvertenza** Questo simbolo di avvertenza indica un pericolo. La situazione potrebbe causare infortuni alle persone. Prima di lavorare su qualsiasi apparecchiatura, occorre conoscere i pericoli relativi ai circuiti elettrici ed essere al corrente delle pratiche standard per la prevenzione di incidenti.

**Advarsel** Dette varselsymbolet betyr fare. Du befinner deg i en situasjon som kan føre til personskade. Før du utfører arbeid på utstyr, må du være oppmerksom på de faremomentene som elektriske kretser innebærer, samt gjøre deg kjent med vanlig praksis når det gjelder å unngå ulykker.

**Aviso** Este símbolo de aviso indica perigo. Encontra-se numa situação que lhe poderá causar danos físicos. Antes de começar a trabalhar com qualquer equipamento, familiarize-se com os perigos relacionados com circuitos eléctricos, e com quaisquer práticas comuns que possam prevenir possíveis acidentes.

**¡Atención!** Este símbolo de aviso significa peligro. Existe riesgo para su integridad física. Antes de manipular cualquier equipo, considerar los riesgos que entraña la corriente eléctrica y familiarizarse con los procedimientos estándar de prevención de accidentes.

**Varning!** Denna varningssymbol signalerar fara. Du befinner dig i en situation som kan leda till personskada. Innan du utför arbete på någon utrustning måste du vara medveten om farorna med elkretsar och känna till vanligt förfarande för att förebygga skador.

## Qualified Personnel Warning



**WARNING:** Only trained and qualified personnel should install or replace the device.

**Waarschuwing** Installatie en reparaties mogen uitsluitend door getraind en bevoegd personeel uitgevoerd worden.

**Varoitus** Ainoastaan koulutettu ja pätevä henkilökunta saa asentaa tai vaihtaa tämän laitteen.

**Avertissement** Tout installation ou remplacement de l'appareil doit être réalisé par du personnel qualifié et compétent.

**Warnung** Gerät nur von geschultem, qualifiziertem Personal installieren oder auswechseln lassen.

**Avvertenza** Solo personale addestrato e qualificato deve essere autorizzato ad installare o sostituire questo apparecchio.

**Advarsel** Kun kvalifisert personell med riktig opplæring bør montere eller bytte ut dette utstyret.

**Aviso** Este equipamento deverá ser instalado ou substituído apenas por pessoal devidamente treinado e qualificado.

**¡Atención!** Estos equipos deben ser instalados y reemplazados exclusivamente por personal técnico adecuadamente preparado y capacitado.

**Varning!** Denna utrustning ska endast installeras och bytas ut av utbildad och kvalificerad personal.

## Warning Statement for Norway and Sweden



**WARNING:** The equipment must be connected to an earthed mains socket-outlet.

**Advarsel** Apparatet skal kobles til en jordet stikkontakt.

**Varning!** Apparaten skall anslutas till jordat nätuttag.

# Fire Safety Requirements

## IN THIS SECTION

- [Fire Suppression | 373](#)
- [Fire Suppression Equipment | 373](#)

In the event of a fire emergency, the safety of people is the primary concern. You should establish procedures for protecting people in the event of a fire emergency, provide safety training, and properly provision fire-control equipment and fire extinguishers.

In addition, you should establish procedures to protect your equipment in the event of a fire emergency. Juniper Networks products should be installed in an environment suitable for electronic equipment. We recommend that fire suppression equipment be available in the event of a fire in the vicinity of the equipment and that all local fire, safety, and electrical codes and ordinances be observed when you install and operate your equipment.

## Fire Suppression

In the event of an electrical hazard or an electrical fire, you should first turn power off to the equipment at the source. Then use a Type C fire extinguisher, which uses noncorrosive fire retardants, to extinguish the fire.

## Fire Suppression Equipment

Type C fire extinguishers, which use noncorrosive fire retardants such as carbon dioxide and Halotron™, are most effective for suppressing electrical fires. Type C fire extinguishers displace oxygen from the point of combustion to eliminate the fire. For extinguishing fire on or around equipment that draws air from the environment for cooling, you should use this type of inert oxygen displacement extinguisher instead of an extinguisher that leaves residues on equipment.

Do not use multipurpose Type ABC chemical fire extinguishers (dry chemical fire extinguishers). The primary ingredient in these fire extinguishers is monoammonium phosphate, which is very sticky and



difficult to clean. In addition, in the presence of minute amounts of moisture, monoammonium phosphate can become highly corrosive and corrodes most metals.

Any equipment in a room in which a chemical fire extinguisher has been discharged is subject to premature failure and unreliable operation. The equipment is considered to be irreparably damaged.

**NOTE:** To keep warranties effective, do not use a dry chemical fire extinguisher to control a fire at or near a Juniper Networks device. If a dry chemical fire extinguisher is used, the unit is no longer eligible for coverage under a service agreement.

We recommend that you dispose of any irreparably damaged equipment in an environmentally responsible manner.

## Installation Instructions Warning



**WARNING:** Read the installation instructions before you connect the device to a power source.

**Waarschuwing** Raadpleeg de installatie-aanwijzingen voordat u het systeem met de voeding verbindt.

**Varoitus** Lue asennusohjeet ennen järjestelmän yhdistämistä virtälähteeseen.

**Avertissement** Avant de brancher le système sur la source d'alimentation, consulter les directives d'installation.

**Warnung** Lesen Sie die Installationsanweisungen, bevor Sie das System an die Stromquelle anschließen.

**Avvertenza** Consultare le istruzioni di installazione prima di collegare il sistema all'alimentatore.

**Advarsel** Les installasjonsinstruksjonene før systemet kobles til strømkilden.

**Aviso** Leia as instruções de instalação antes de ligar o sistema à sua fonte de energia.

**¡Atención!** Ver las instrucciones de instalación antes de conectar el sistema a la red de alimentación.

**Varning!** Läs installationsanvisningarna innan du kopplar systemet till dess strömförsörjningsenhet.

## Chassis and Component Lifting Guidelines

- Before moving the device to a site, ensure that the site meets the power, environmental, and clearance requirements.
- Before lifting or moving the device, disconnect all external cables and wires.
- As when lifting any heavy object, ensure that your legs bear most of the weight rather than your back. Keep your knees bent and your back relatively straight. Do not twist your body as you lift. Balance the load evenly and be sure that your footing is firm.
- Use the following lifting guidelines to lift devices and components:
  - Up to 39.7 lb (18 kg): One person.
  - From 39.7 lb (18 kg) to 70.5 lb (32 kg): Two or more people.
  - From 70.5 lb (32 kg) to 121.2 lb (55 kg): Three or more people.
  - Above 121.2 lb (55 kg): Use material handling systems (such as levers, slings, lifts, and so on). When this is not practical, engage specially trained persons or systems (such as riggers or movers).

## Restricted Access Warning



**WARNING:** This unit is intended for installation in restricted access areas. A restricted access area is an area to which access can be gained only by service personnel through the use of a special tool, lock and key, or other means of security, and which is controlled by the authority responsible for the location.

**Waarschuwing** Dit toestel is bedoeld voor installatie op plaatsen met beperkte toegang. Een plaats met beperkte toegang is een plaats waar toegang slechts door servicepersoneel verkregen kan worden door middel van een speciaal instrument, een slot en sleutel, of een ander veiligheidsmiddel, en welke beheerd wordt door de overheidsinstantie die verantwoordelijk is voor de locatie.

**Varoitus** Tämä laite on tarkoitettu asennettavaksi paikkaan, johon pääsy on rajoitettua. Paikka, johon pääsy on rajoitettua, tarkoittaa paikkaa, johon vain huoltohenkilöstö pääsee jonkin erikoistyökalun, lukkoon sopivan avaimen tai jonkin muun turvalaitteen avulla ja joka on paikasta vastuussa olevien toimivaltaisten henkilöiden valvoma.

**Avertissement** Cet appareil est à installer dans des zones d'accès réservé. Ces dernières sont des zones auxquelles seul le personnel de service peut accéder en utilisant un outil spécial, un mécanisme de verrouillage et une clé, ou tout autre moyen de sécurité. L'accès aux zones de sécurité est sous le contrôle de l'autorité responsable de l'emplacement.

**Warnung** Diese Einheit ist zur Installation in Bereichen mit beschränktem Zutritt vorgesehen. Ein Bereich mit beschränktem Zutritt ist ein Bereich, zu dem nur Wartungspersonal mit einem Spezialwerkzeugs, Schloß und Schlüssel oder anderer Sicherheitsvorkehrungen Zugang hat, und der von dem für die Anlage zuständigen Gremium kontrolliert wird.

**Avvertenza** Questa unità deve essere installata in un'area ad accesso limitato. Un'area ad accesso limitato è un'area accessibile solo a personale di assistenza tramite un'attrezzo speciale, lucchetto, o altri dispositivi di sicurezza, ed è controllata dall'autorità responsabile della zona.

**Advarsel** Denne enheten er laget for installasjon i områder med begrenset adgang. Et område med begrenset adgang gir kun adgang til servicepersonale som bruker et spesielt verktøy, lås og nøkkel, eller en annen sikkerhetsanordning, og det kontrolleres av den autoriteten som er ansvarlig for området.

**Aviso** Esta unidade foi concebida para instalação em áreas de acesso restrito. Uma área de acesso restrito é uma área à qual apenas tem acesso o pessoal de serviço autorizado, que possua uma ferramenta, chave e fechadura especial, ou qualquer outra forma de segurança. Esta área é controlada pela autoridade responsável pelo local.

**¡Atención!** Esta unidad ha sido diseñada para instalarse en áreas de acceso restringido. Área de acceso restringido significa un área a la que solamente tiene acceso el personal de servicio mediante la utilización de una herramienta especial, cerradura con llave, o algún otro medio de seguridad, y que está bajo el control de la autoridad responsable del local.

**Warning!** Denna enhet är avsedd för installation i områden med begränsat tillträde. Ett område med begränsat tillträde får endast tillträdas av servicepersonal med ett speciellt verktyg, lås och nyckel, eller annan säkerhetsanordning, och kontrolleras av den auktoritet som ansvarar för området.

## Ramp Warning



**WARNING:** When installing the device, do not use a ramp inclined at more than 10 degrees.

**Waarschuwing** Gebruik een oprijplaat niet onder een hoek van meer dan 10 graden.

**Varoitus** Älä käytä sellaista kaltevaa pintaa, jonka kaltevuus ylittää 10 astetta.

**Avertissement** Ne pas utiliser une rampe dont l'inclinaison est supérieure à 10 degrés.

**Warnung** Keine Rampen mit einer Neigung von mehr als 10 Grad verwenden.

**Avvertenza** Non usare una rampa con pendenza superiore a 10 gradi.

**Advarsel** Bruk aldri en rampe som heller mer enn 10 grader.

**Aviso** Não utilize uma rampa com uma inclinação superior a 10 graus.

**¡Atención!** No usar una rampa inclinada más de 10 grados.

**Varning!** Använd inte ramp med en lutning på mer än 10 grader.

## Rack-Mounting and Cabinet-Mounting Warnings

Ensure that the rack or cabinet in which the device is installed is evenly and securely supported. Uneven mechanical loading could lead to a hazardous condition.



**WARNING:** To prevent bodily injury when mounting or servicing the device in a rack, take the following precautions to ensure that the system remains stable. The following directives help maintain your safety:

- Install the device in a rack that is secured to the building structure.
- Mount the device at the bottom of the rack if it is the only unit in the rack.
- When mounting the device on a partially filled rack, load the rack from the bottom to the top, with the heaviest component at the bottom of the rack.

- If the rack is provided with stabilizing equipment, install the stabilizers before mounting or servicing the device in the rack.

**Waarschuwing** Om lichamelijk letsel te voorkomen wanneer u dit toestel in een rek monteert of het daar een servicebeurt geeft, moet u speciale voorzorgsmaatregelen nemen om ervoor te zorgen dat het toestel stabiel blijft. De onderstaande richtlijnen worden verstrekt om uw veiligheid te verzekeren:

- De Juniper Networks switch moet in een stellage worden geïnstalleerd die aan een bouwsel is verankerd.
- Dit toestel dient onderaan in het rek gemonteerd te worden als het toestel het enige in het rek is.
- Wanneer u dit toestel in een gedeeltelijk gevuld rek monteert, dient u het rek van onderen naar boven te laden met het zwaarste onderdeel onderaan in het rek.
- Als het rek voorzien is van stabiliseringshulpmiddelen, dient u de stabilisatoren te monteren voordat u het toestel in het rek monteert of het daar een servicebeurt geeft.

**Varoitus** Kun laite asetetaan telineeseen tai huolletaan sen ollessa telineessä, on noudatettava erityisiä varotoimia järjestelmän vakavuuden säilyttämiseksi, jotta vältetään loukkaantumiselta. Noudata seuraavia turvallisuusohjeita:

- Juniper Networks switch on asennettava telineeseen, joka on kiinnitetty rakennukseen.
- Jos telineessä ei ole muita laitteita, aseta laite telineen alaosaan.
- Jos laite asetetaan osaksi täytettyyn telineeseen, aloita kuormittaminen sen alaosasta kaikkein raskaimmalla esineellä ja siirry sitten sen yläosaan.
- Jos telinettä varten on vakaimet, asenna ne ennen laitteen asettamista telineeseen tai sen huoltamista siinä.

**Avertissement** Pour éviter toute blessure corporelle pendant les opérations de montage ou de réparation de cette unité en casier, il convient de prendre des précautions spéciales afin de maintenir la stabilité du système. Les directives ci-dessous sont destinées à assurer la protection du personnel:

- Le rack sur lequel est monté le Juniper Networks switch doit être fixé à la structure du bâtiment.

- Si cette unité constitue la seule unité montée en casier, elle doit être placée dans le bas.
- Si cette unité est montée dans un casier partiellement rempli, charger le casier de bas en haut en plaçant l'élément le plus lourd dans le bas.
- Si le casier est équipé de dispositifs stabilisateurs, installer les stabilisateurs avant de monter ou de réparer l'unité en casier.

**Warnung** Zur Vermeidung von Körperverletzung beim Anbringen oder Warten dieser Einheit in einem Gestell müssen Sie besondere Vorkehrungen treffen, um sicherzustellen, daß das System stabil bleibt. Die folgenden Richtlinien sollen zur Gewährleistung Ihrer Sicherheit dienen:

- Der Juniper Networks switch muß in einem Gestell installiert werden, das in der Gebäudestruktur verankert ist.
- Wenn diese Einheit die einzige im Gestell ist, sollte sie unten im Gestell angebracht werden.
- Bei Anbringung dieser Einheit in einem zum Teil gefüllten Gestell ist das Gestell von unten nach oben zu laden, wobei das schwerste Bauteil unten im Gestell anzubringen ist.
- Wird das Gestell mit Stabilisierungszubehör geliefert, sind zuerst die Stabilisatoren zu installieren, bevor Sie die Einheit im Gestell anbringen oder sie warten.

**Avvertenza** Per evitare infortuni fisici durante il montaggio o la manutenzione di questa unità in un supporto, occorre osservare speciali precauzioni per garantire che il sistema rimanga stabile. Le seguenti direttive vengono fornite per garantire la sicurezza personale:

- Il Juniper Networks switch deve essere installato in un telaio, il quale deve essere fissato alla struttura dell'edificio.
- Questa unità deve venire montata sul fondo del supporto, se si tratta dell'unica unità da montare nel supporto.
- Quando questa unità viene montata in un supporto parzialmente pieno, caricare il supporto dal basso all'alto, con il componente più pesante sistemato sul fondo del supporto.
- Se il supporto è dotato di dispositivi stabilizzanti, installare tali dispositivi prima di montare o di procedere alla manutenzione dell'unità nel supporto.

**Advarsel** Unngå fysiske skader under montering eller reparasjonsarbeid på denne enheten når den befinner seg i et kabinett. Vær nøye med at systemet er stabilt. Følgende retningslinjer er gitt for å verne om sikkerheten:

- Juniper Networks switch må installeres i et stativ som er forankret til bygningsstrukturen.
- Denne enheten bør monteres nederst i kabinettet hvis dette er den eneste enheten i kabinettet.
- Ved montering av denne enheten i et kabinett som er delvis fylt, skal kabinettet lastes fra bunnen og opp med den tyngste komponenten nederst i kabinettet.
- Hvis kabinettet er utstyrt med stabiliseringsutstyr, skal stabilisatorene installeres før montering eller utføring av reparasjonsarbeid på enheten i kabinettet.

**Aviso** Para se prevenir contra danos corporais ao montar ou reparar esta unidade numa estante, deverá tomar precauções especiais para se certificar de que o sistema possui um suporte estável. As seguintes directrizes ajudá-lo-ão a efectuar o seu trabalho com segurança:

- O Juniper Networks switch deverá ser instalado numa prateleira fixa à estrutura do edifício.
- Esta unidade deverá ser montada na parte inferior da estante, caso seja esta a única unidade a ser montada.
- Ao montar esta unidade numa estante parcialmente ocupada, coloque os itens mais pesados na parte inferior da estante, arrumando-os de baixo para cima.
- Se a estante possuir um dispositivo de estabilização, instale-o antes de montar ou reparar a unidade.

**¡Atención!** Para evitar lesiones durante el montaje de este equipo sobre un bastidor, oerriormente durante su mantenimiento, se debe poner mucho cuidado en que el sistema quede bien estable. Para garantizar su seguridad, proceda según las siguientes instrucciones:

- El Juniper Networks switch debe instalarse en un bastidor fijado a la estructura del edificio.
- Colocar el equipo en la parte inferior del bastidor, cuando sea la única unidad en el mismo.

- Cuando este equipo se vaya a instalar en un bastidor parcialmente ocupado, comenzar la instalación desde la parte inferior hacia la superior colocando el equipo más pesado en la parte inferior.
- Si el bastidor dispone de dispositivos estabilizadores, instalar éstos antes de montar o proceder al mantenimiento del equipo instalado en el bastidor.

**Warning!** För att undvika kroppsskada när du installerar eller utför underhållsarbete på denna enhet på en ställning måste du vidta särskilda försiktighetsåtgärder för att försäkra dig om att systemet står stadigt. Följande riktlinjer ges för att trygga din säkerhet:

- Juniper Networks switch måste installeras i en ställning som är förankrad i byggnadens struktur.
- Om denna enhet är den enda enheten på ställningen skall den installeras längst ned på ställningen.
- Om denna enhet installeras på en delvis fylld ställning skall ställningen fyllas nedifrån och upp, med de tyngsta enheterna längst ned på ställningen.
- Om ställningen är försedd med stabiliseringsdon skall dessa monteras fast innan enheten installeras eller underhålls på ställningen.

## Grounded Equipment Warning



**WARNING:** This device must be properly grounded at all times. Follow the instructions in this guide to properly ground the device to earth.

**Waarschuwing** Dit apparaat moet altijd goed geaard zijn. Volg de instructies in deze gids om het apparaat goed te aarden.

**Varoitus** Laitteen on oltava pysyvästi maadoitettu. Maadoita laite asianmukaisesti noudattamalla tämän oppaan ohjeita.

**Avertissement** L'appareil doit être correctement mis à la terre à tout moment. Suivez les instructions de ce guide pour correctement mettre l'appareil à la terre.

**Warnung** Das Gerät muss immer ordnungsgemäß geerdet sein. Befolgen Sie die Anweisungen in dieser Anleitung, um das Gerät ordnungsgemäß zu erden.



**Avvertenza** Questo dispositivo deve sempre disporre di una connessione a massa. Seguire le istruzioni indicate in questa guida per connettere correttamente il dispositivo a massa.

**Advarsel** Denne enheten på jordes skikkelig hele tiden. Følg instruksjonene i denne veiledningen for å jorde enheten.

**Aviso** Este equipamento deverá estar ligado à terra. Siga las instrucciones en esta guía para conectar correctamente este dispositivo a tierra.

**¡Atención!** Este dispositivo debe estar correctamente conectado a tierra en todo momento. Siga las instrucciones en esta guía para conectar correctamente este dispositivo a tierra.

**Varning!** Den här enheten måste vara ordentligt jordad. Följ instruktionerna i den här guiden för att jorda enheten ordentligt.

## Radiation from Open Port Apertures Warning



**LASER WARNING:** Because invisible radiation might be emitted from the aperture of the port when no fiber cable is connected, avoid exposure to radiation and do not stare into open apertures.

**Waarschuwing** Aangezien onzichtbare straling vanuit de opening van de poort kan komen als er geen fiberkabel aangesloten is, dient blootstelling aan straling en het kijken in open openingen vermeden te worden.

**Varoitus** Koska portin aukosta voi emittoitua näkymätöntä säteilyä, kun kuitukaapelia ei ole kytkettyä, vältä säteilylle altistumista äläkä katso avoimiin aukkoihin.

**Avertissement** Des radiations invisibles à l'il nu pouvant traverser l'ouverture du port lorsqu'aucun câble en fibre optique n'y est connecté, il est recommandé de ne pas regarder fixement l'intérieur de ces ouvertures.

**Warnung** Aus der Port-Öffnung können unsichtbare Strahlen emittieren, wenn kein Glasfaserkabel angeschlossen ist. Vermeiden Sie es, sich den Strahlungen auszusetzen, und starren Sie nicht in die Öffnungen!

**Avvertenza** Quando i cavi in fibra non sono inseriti, radiazioni invisibili possono essere emesse attraverso l'apertura della porta. Evitate di esporvi alle radiazioni e non guardate direttamente nelle aperture.

**Advarsel** Unngå utsettelse for stråling, og stirr ikke inn i åpninger som er åpne, fordi usynlig stråling kan emitteres fra portens åpning når det ikke er tilkoblet en fiberkabel.

**Aviso** Dada a possibilidade de emissão de radiação invisível através do orifício da via de acesso, quando esta não tiver nenhum cabo de fibra conectado, deverá evitar a EXposição à radiação e não deverá olhar fixamente para orifícios que se encontrarem a descoberto.

**¡Atención!** Debido a que la apertura del puerto puede emitir radiación invisible cuando no existe un cable de fibra conectado, evite mirar directamente a las aperturas para no exponerse a la radiación.

**Varning!** Osynlig strålning kan avges från en portöppning utan ansluten fiberkabel och du bör därför undvika att bli utsatt för strålning genom att inte stirra in i oskyddade öppningar.

## Laser and LED Safety Guidelines and Warnings for the QFX Series

### IN THIS SECTION

- [Class 1M Laser Product Warning | 384](#)
- [Class 1M Laser Radiation Warning | 384](#)
- [Unterminated Fiber-Optic Cable Warning | 385](#)

In addition to the general guidelines provided in [Laser and LED Safety Guidelines and Warnings](#), follow these warnings and guidelines that are specific to QFX Series devices.

QFX Series devices are equipped with laser transmitters:

- SFP and SFP+ transceivers are classified as Class 1 Laser Products (complies with 21 CFR 1040.10 and 1040.11 except for deviations pursuant to Laser Notice 50, dated July 26, 2001) or Class 1 LED Products.
- QSFP+ and QSFP28 transceivers are classified as Class 1M Laser Products (IEC 60825-1 2001-01).

Observe the following guidelines and warnings:

## Class 1M Laser Product Warning



**LASER WARNING:** Class 1M laser product.

**Waarschuwing** Laserproducten van Klasse 1M (IEC).

**Varoitus** Luokan 1M (IEC) lasertuotteita.

**Attention** Produits laser catégorie 1M (IEC).

**Warnung** Laserprodukte der Klasse 1M (IEC).

**Avvertenza** Prodotti laser di Classe 1M (IEC).

**Advarsel** Klasse 1M (IEC) laserprodukter.

**Aviso** Produtos laser Classe 1M (IEC).

**¡Atención!** Productos láser de Clase 1M (IEC).

**Varning!** Laserprodukter av Klass 1M (IEC).

## Class 1M Laser Radiation Warning



**LASER WARNING:** Class 1M laser radiation when open. Do not view directly with optical instruments.

## Unterminated Fiber-Optic Cable Warning



**WARNING:** Invisible laser radiation might be emitted from the unterminated connector of a fiber-optic cable. To avoid injury to your eye, do not view the fiber optics with a magnifying optical device, such as a loupe, within 100 mm.

**Waarschuwing** Er kunnen onzichtbare laserstralen worden uitgezonden vanuit het uiteinde van de onafgebroken vezelkabel of connector. Niet in de straal kijken of deze rechtstreeks bekijken met optische instrumenten. Als u de laseruitvoer met bepaalde optische instrumenten bekijkt (zoals bijv. een oogloep, vergrootglas of microscoop) binnen een afstand van 100 mm kan dit gevaar voor uw ogen opleveren.

**Varoitus** Päättämättömän kuitukaapelin tai -liittimen päästä voi tulla näkymätöntä lasersäteilyä. Älä tuijota sädetä tai katso sitä suoraan optisilla välineillä. Lasersäteen katsominen tietyillä optisilla välineillä (esim. suurennuslasilla tai mikroskoopilla) 10 cm:n päästä tai sitä lähempää voi olla vaarallista silmille.

**Attention** Des émissions de radiations laser invisibles peuvent se produire à l'extrémité d'un câble en fibre ou d'un raccord sans terminaison. Ne pas fixer du regard le rayon ou l'observer directement avec des instruments optiques. L'observation du laser à l'aide certains instruments optiques (loupes et microscopes) à une distance inférieure à 100 mm peut poser des risques pour les yeux.

**Warnung** Eine unsichtbare Laserstrahlung kann vom Ende des nicht angeschlossenen Glasfaserkabels oder Steckers ausgestrahlt werden. Nicht in den Laserstrahl schauen oder diesen mit einem optischen Instrument direkt ansehen. Ein Betrachten des Laserstrahls mit bestimmten optischen Instrumenten, wie z.B. Augenlupen, Vergrößerungsgläsern und Mikroskopen innerhalb eines Abstands von 100 mm kann für das Auge gefährlich sein.

**Avvertenza** L'estremità del connettore o del cavo ottico senza terminazione può emettere radiazioni laser invisibili. Non fissare il raggio od osservarlo in modo diretto con strumenti ottici. L'osservazione del fascio laser con determinati strumenti ottici (come lupette, lenti di ingrandimento o microscopi) entro una distanza di 100 mm può provocare danni agli occhi.

**Advarsel** Usynlig laserstråling kan emitte fra enden av den ikke-terminerte fiberkabelen eller koblingen. Ikke se inn i strålen og se heller ikke direkte på strålen med optiske instrumenter. Observering av laserutgang med visse optiske instrumenter (for eksempel øyelupe, forstørrelsesglass eller mikroskoper) innenfor en avstand på 100 mm kan være farlig for øynene.

**Aviso** Radiação laser invisível pode ser emitida pela ponta de um conector ou cabo de fibra não terminado. Não olhe fixa ou diretamente para o feixe ou com instrumentos ópticos. Visualizar a emissão do laser com certos instrumentos ópticos (por exemplo, lupas, lentes de aumento ou microscópios) a uma distância de 100 mm pode causar riscos à visão.

**¡Atención!** El extremo de un cable o conector de fibra sin terminación puede emitir radiación láser invisible. No se acerque al radio de acción ni lo mire directamente con instrumentos ópticos. La exposición del ojo a una salida de láser con determinados instrumentos ópticos (por ejemplo, lupas y microscopios) a una distancia de 100 mm puede comportar lesiones oculares.

**Warning!** Osynlig laserstrålning kan komma från änden på en oavslutad fiberkabel eller -anslutning. Titta inte rakt in i strålen eller direkt på den med optiska instrument. Att titta på laserstrålen med vissa optiska instrument (t.ex. lupper, förstoringsglas och mikroskop) från ett avstånd på 100 mm kan skada ögonen.

## RELATED DOCUMENTATION

*General Safety Guidelines and Warnings*

*Radiation from Open Port Apertures Warning*

*Installation Instructions Warning*

*Grounded Equipment Warning*

# Maintenance and Operational Safety Guidelines and Warnings

## IN THIS SECTION

- [Battery Handling Warning | 387](#)
- [Jewelry Removal Warning | 388](#)
- [Lightning Activity Warning | 389](#)
- [Operating Temperature Warning | 390](#)

While performing the maintenance activities for devices, observe the following guidelines and warnings:

## Battery Handling Warning



**WARNING:** Replacing a battery incorrectly might result in an explosion. Replace a battery only with the same or equivalent type recommended by the manufacturer. Dispose of used batteries according to the manufacturer's instructions.

**Waarschuwing** Er is ontploffingsgevaar als de batterij verkeerd vervangen wordt. Vervang de batterij slechts met hetzelfde of een equivalent type dat door de fabrikant aanbevolen is. Gebruikte batterijen dienen overeenkomstig fabrieksvoorschriften weggeworpen te worden.

**Varoitus** Räjähdyksen vaara, jos akku on vaihdettu väärään akkuun. Käytä vaihtamiseen ainoastaan saman- tai vastaavantyyppistä akkua, joka on valmistajan suositttelema. Hävitä käytetyt akut valmistajan ohjeiden mukaan.

**Avertissement** Danger d'explosion si la pile n'est pas remplacée correctement. Ne la remplacer que par une pile de type semblable ou équivalent, recommandée par le fabricant. Jeter les piles usagées conformément aux instructions du fabricant.

**Warnung** Bei Einsetzen einer falschen Batterie besteht Explosionsgefahr. Ersetzen Sie die Batterie nur durch den gleichen oder vom Hersteller empfohlenen Batterietyp. Entsorgen Sie die benutzten Batterien nach den Anweisungen des Herstellers.

**Advarsel** Det kan være fare for eksplosjon hvis batteriet skiftes på feil måte. Skift kun med samme eller tilsvarende type som er anbefalt av produsenten. Kasser brukte batterier i henhold til produsentens instruksjoner.

**Avvertenza** Pericolo di esplosione se la batteria non è installata correttamente. Sostituire solo con una di tipo uguale o equivalente, consigliata dal produttore. Eliminare le batterie usate secondo le istruzioni del produttore.

**Aviso** Existe perigo de explosão se a bateria for substituída incorrectamente. Substitua a bateria por uma bateria igual ou de um tipo equivalente recomendado pelo fabricante. Destrua as baterias usadas conforme as instruções do fabricante.

**¡Atención!** Existe peligro de explosión si la batería se reemplaza de manera incorrecta. Reemplazar la batería EXclusivamente con el mismo tipo o el equivalente recomendado por el fabricante. Desechar las baterías gastadas según las instrucciones del fabricante.

**Warning!** Explosionsfara vid felaktigt batteribyte. Ersätt endast batteriet med samma batterityp som rekommenderas av tillverkaren eller motsvarande. Följ tillverkarens anvisningar vid kassering av använda batterier.

## Jewelry Removal Warning



**WARNING:** Before working on equipment that is connected to power lines, remove jewelry, including rings, necklaces, and watches. Metal objects heat up when connected to power and ground and can cause serious burns or can be welded to the terminals.

**Waarschuwing** Alvorens aan apparatuur te werken die met elektrische leidingen is verbonden, sieraden (inclusief ringen, kettingen en horloges) verwijderen. Metalen voorwerpen worden warm wanneer ze met stroom en aarde zijn verbonden, en kunnen ernstige brandwonden veroorzaken of het metalen voorwerp aan de aansluitklemmen lassen.

**Varoitus** Ennen kuin työskentelet voimavirtajohtoihin kytkettyjen laitteiden parissa, ota pois kaikki korut (sormukset, kaulakorut ja kellot mukaan lukien). Metalliesineet kuumenevat, kun ne ovat yhteydessä sähkövirran ja maan kanssa, ja ne voivat aiheuttaa vakavia palovammoja tai hitsata metalliesineet kiinni liitäntänapoihin.

**Avertissement** Avant d'accéder à cet équipement connecté aux lignes électriques, ôter tout bijou (anneaux, colliers et montres compris). Lorsqu'ils sont branchés à l'alimentation et reliés à la terre, les objets métalliques chauffent, ce qui peut provoquer des blessures graves ou souder l'objet métallique aux bornes.

**Warnung** Vor der Arbeit an Geräten, die an das Netz angeschlossen sind, jeglichen Schmuck (einschließlich Ringe, Ketten und Uhren) abnehmen. Metallgegenstände erhitzen sich, wenn sie an das Netz und die Erde angeschlossen werden, und können schwere Verbrennungen verursachen oder an die Anschlußklemmen angeschweißt werden.

**Avvertenza** Prima di intervenire su apparecchiature collegate alle linee di alimentazione, togliersi qualsiasi monile (inclusi anelli, collane, braccialetti ed orologi). Gli oggetti

metallici si riscaldano quando sono collegati tra punti di alimentazione e massa: possono causare ustioni gravi oppure il metallo può saldarsi ai terminali.

**Advarsel** Fjern alle smykker (inkludert ringer, halskjeder og klokker) før du skal arbeide på utstyr som er koblet til kraftledninger. Metallgjenstander som er koblet til kraftledninger og jord blir svært varme og kan forårsake alvorlige brannskader eller smelte fast til polene.

**Aviso** Antes de trabalhar em equipamento que esteja ligado a linhas de corrente, retire todas as jóias que estiver a usar (incluindo anéis, fios e relógios). Os objectos metálicos aquecerão em contacto com a corrente e em contacto com a ligação à terra, podendo causar queimaduras graves ou ficarem soldados aos terminais.

**¡Atención!** Antes de operar sobre equipos conectados a líneas de alimentación, quitarse las joyas (incluidos anillos, collares y relojes). Los objetos de metal se calientan cuando se conectan a la alimentación y a tierra, lo que puede ocasionar quemaduras graves o que los objetos metálicos queden soldados a los bornes.

**Warning!** Tag av alla smycken (inklusive ringar, halsband och armbandsur) innan du arbetar på utrustning som är kopplad till kraftledningar. Metallobjekt hettas upp när de kopplas ihop med ström och jord och kan förorsaka allvarliga brännskador; metallobjekt kan också sammansvetsas med kontakterna.

## Lightning Activity Warning



**WARNING:** Do not work on the system or connect or disconnect cables during periods of lightning activity.

**Waarschuwing** Tijdens onweer dat gepaard gaat met bliksem, dient u niet aan het systeem te werken of kabels aan te sluiten of te ontkoppelen.

**Varoitus** Älä työskentele järjestelmän parissa äläkä yhdistä tai irrota kaapeleita ukkosilmalla.

**Avertissement** Ne pas travailler sur le système ni brancher ou débrancher les câbles pendant un orage.

**Warnung** Arbeiten Sie nicht am System und schließen Sie keine Kabel an bzw. trennen Sie keine ab, wenn es gewittert.



**Avvertenza** Non lavorare sul sistema o collegare oppure scollegare i cavi durante un temporale con fulmini.

**Advarsel** Utfør aldri arbeid på systemet, eller koble kabler til eller fra systemet når det tordner eller lyner.

**Aviso** Não trabalhe no sistema ou ligue e desligue cabos durante períodos de mau tempo (trovoada).

**¡Atención!** No operar el sistema ni conectar o desconectar cables durante el transcurso de descargas eléctricas en la atmósfera.

**Varning!** Vid åska skall du aldrig utföra arbete på systemet eller ansluta eller koppla loss kablar.

## Operating Temperature Warning



**WARNING:** To prevent the device from overheating, do not operate it in an area that exceeds the maximum recommended ambient temperature. To prevent airflow restriction, allow at least 6 in. (15.2 cm) of clearance around the ventilation openings.

**Waarschuwing** Om te voorkomen dat welke switch van de Juniper Networks router dan ook oververhit raakt, dient u deze niet te bedienen op een plaats waar de maximale aanbevolen omgevingstemperatuur van 40° C wordt overschreden. Om te voorkomen dat de luchtstroom wordt beperkt, dient er minstens 15,2 cm speling rond de ventilatie-openingen te zijn.

**Varoitus** Ettei Juniper Networks switch-sarjan reititin ylikuumentuisi, sitä ei saa käyttää tilassa, jonka lämpötila ylittää korkeimman suositellun ympäristölämpötilan 40° C. Ettei ilmanvaihto estyisi, tuuletusaukkojen ympärille on jätettävä ainakin 15,2 cm tilaa.

**Avertissement** Pour éviter toute surchauffe des routeurs de la gamme Juniper Networks switch, ne l'utilisez pas dans une zone où la température ambiante est supérieure à 40° C. Pour permettre un flot d'air constant, dégagez un espace d'au moins 15,2 cm autour des ouvertures de ventilations.

**Warnung** Um einen Router der switch vor Überhitzung zu schützen, darf dieser nicht in einer Gegend betrieben werden, in der die Umgebungstemperatur das empfohlene Maximum von 40° C überschreitet. Um Lüftungsverschluß zu verhindern, achten Sie

darauf, daß mindestens 15,2 cm lichter Raum um die Lüftungsöffnungen herum frei bleibt.

**Avvertenza** Per evitare il surriscaldamento dei switch, non adoperateli in un locale che ecceda la temperatura ambientale massima di 40° C. Per evitare che la circolazione dell'aria sia impedita, lasciate uno spazio di almeno 15.2 cm di fronte alle aperture delle ventole.

**Advarsel** Unngå overoppheting av eventuelle rutere i Juniper Networks switch Disse skal ikke brukes på steder der den anbefalte maksimale omgivelsestemperaturen overstiger 40° C (104° F). Sørg for at klaringen rundt lufteåpningene er minst 15,2 cm (6 tommer) for å forhindre nedsatt luftsirkulasjon.

**Aviso** Para evitar o sobreaquecimento do encaminhador Juniper Networks switch, não utilize este equipamento numa área que exceda a temperatura máxima recomendada de 40° C. Para evitar a restrição à circulação de ar, deixe pelo menos um espaço de 15,2 cm à volta das aberturas de ventilação.

**¡Atención!** Para impedir que un encaminador de la serie Juniper Networks switch se recaliente, no lo haga funcionar en un área en la que se supere la temperatura ambiente máxima recomendada de 40° C. Para impedir la restricción de la entrada de aire, deje un espacio mínimo de 15,2 cm alrededor de las aperturas para ventilación.

**Warning!** Förhindra att en Juniper Networks switch överhettas genom att inte använda den i ett område där den maximalt rekommenderade omgivningstemperaturen på 40° C överskrids. Förhindra att luftcirkulationen inskränks genom att se till att det finns fritt utrymme på minst 15,2 cm omkring ventilationsöppningarna.

## Product Disposal Warning



**WARNING:** Disposal of this device must be handled according to all national laws and regulations.

**Waarschuwing** Dit produkt dient volgens alle landelijke wetten en voorschriften te worden afgedankt.

**Varoitus** Tämän tuotteen lopullisesta hävittämisestä tulee huolehtia kaikkia valtakunnallisia lakeja ja säännöksiä noudattaen.

**Avertissement** La mise au rebut définitive de ce produit doit être effectuée conformément à toutes les lois et réglementations en vigueur.

**Warnung** Dieses Produkt muß den geltenden Gesetzen und Vorschriften entsprechend entsorgt werden.

**Avvertenza** L'eliminazione finale di questo prodotto deve essere eseguita osservando le normative italiane vigenti in materia

**Advarsel** Endelig disponering av dette produktet må skje i henhold til nasjonale lover og forskrifter.

**Aviso** A descartagem final deste produto deverá ser efectuada de acordo com os regulamentos e a legislação nacional.

**¡Atención!** El desecho final de este producto debe realizarse según todas las leyes y regulaciones nacionales

**Warning!** Slutlig kassering av denna produkt bör skötas i enlighet med landets alla lagar och föreskrifter.

## General Electrical Safety Guidelines and Warnings



**WARNING:** Certain ports on the device are designed for use as intrabuilding (within-the-building) interfaces only (Type 2 or Type 4 ports as described in *GR-1089-CORE*) and require isolation from the exposed outside plant (OSP) cabling. To comply with NEBS (Network Equipment-Building System) requirements and protect against lightning surges and commercial power disturbances, the intrabuilding ports *must not* be metallically connected to interfaces that connect to the OSP or its wiring. The intrabuilding ports on the device are suitable for connection to intrabuilding or unexposed wiring or cabling only. The addition of primary protectors is not sufficient protection for connecting these interfaces metallically to OSP wiring.

**Avertissement** Certains ports de l'appareil sont destinés à un usage en intérieur uniquement (ports Type 2 ou Type 4 tels que décrits dans le document *GR-1089-CORE*) et doivent être isolés du câblage de l'installation extérieure exposée. Pour respecter les exigences NEBS et assurer une protection contre la foudre et les perturbations de tension secteur, les ports pour intérieur *ne doivent pas* être raccordés physiquement aux interfaces prévues pour la connexion à l'installation extérieure ou à son câblage. Les

ports pour intérieur de l'appareil sont réservés au raccordement de câbles pour intérieur ou non exposés uniquement. L'ajout de protections ne constitue pas une précaution suffisante pour raccorder physiquement ces interfaces au câblage de l'installation extérieure.



**CAUTION:** Before removing or installing components of a device, connect an electrostatic discharge (ESD) grounding strap to an ESD point and wrap and fasten the other end of the strap around your bare wrist. Failure to use an ESD grounding strap could result in damage to the device.

**Attention** Avant de retirer ou d'installer des composants d'un appareil, raccordez un bracelet antistatique à un point de décharge électrostatique et fixez le bracelet à votre poignet nu. L'absence de port d'un bracelet antistatique pourrait provoquer des dégâts sur l'appareil.

- Install the device in compliance with the following local, national, and international electrical codes:
  - United States—National Fire Protection Association (NFPA 70), United States National Electrical Code.
  - Other countries—International Electromechanical Commission (IEC) 60364, Part 1 through Part 7.
  - Evaluated to the TN power system.
  - Canada—Canadian Electrical Code, Part 1, CSA C22.1.
  - Suitable for installation in Information Technology Rooms in accordance with Article 645 of the National Electrical Code and NFPA 75.

Peut être installé dans des salles de matériel de traitement de l'information conformément à l'article 645 du National Electrical Code et à la NFPA 75.
- Locate the emergency power-off switch for the room in which you are working so that if an electrical accident occurs, you can quickly turn off the power.
- Make sure that you clean grounding surface and give them a bright finish before making grounding connections.
- Do not work alone if potentially hazardous conditions exist anywhere in your workspace.
- Never assume that power is disconnected from a circuit. Always check the circuit before starting to work.
- Carefully look for possible hazards in your work area, such as moist floors, ungrounded power extension cords, and missing safety grounds.

- Operate the device within marked electrical ratings and product usage instructions.
- To ensure that the device and peripheral equipment function safely and correctly, use the cables and connectors specified for the attached peripheral equipment, and make certain they are in good condition.

You can remove and replace many device components without powering off or disconnecting power to the device, as detailed elsewhere in the hardware documentation for this device. Never install equipment that appears to be damaged.

## Action to Take After an Electrical Accident

If an electrical accident results in an injury, take the following actions in this order:

1. Use caution. Be aware of potentially hazardous conditions that could cause further injury.
2. Disconnect power from the device.
3. If possible, send another person to get medical aid. Otherwise, assess the condition of the victim, and then call for help.

## Prevention of Electrostatic Discharge Damage

Device components that are shipped in antistatic bags are sensitive to damage from static electricity. Some components can be impaired by voltages as low as 30 V. You can easily generate potentially damaging static voltages whenever you handle plastic or foam packing material or if you move components across plastic or carpets. Observe the following guidelines to minimize the potential for electrostatic discharge (ESD) damage, which can cause intermittent or complete component failures:

- Always use an ESD wrist strap when you are handling components that are subject to ESD damage, and make sure that it is in direct contact with your skin.

If a grounding strap is not available, hold the component in its antistatic bag (see [Figure 220 on page 395](#)) in one hand and touch the exposed, bare metal of the device with the other hand immediately before inserting the component into the device.



**WARNING:** For safety, periodically check the resistance value of the ESD grounding strap. The measurement must be in the range 1 through 10 Mohms.

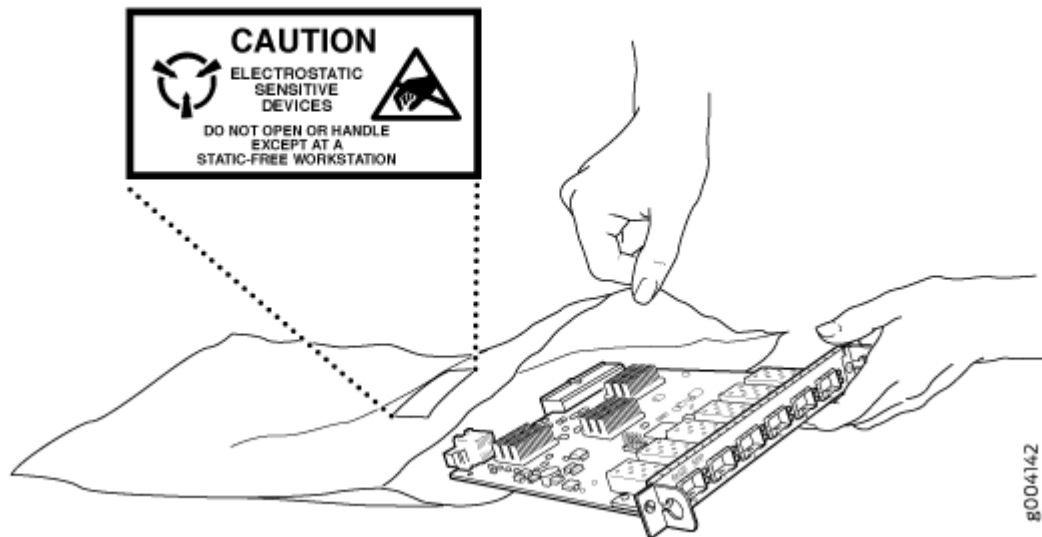
**Avertissement** Par mesure de sécurité, vérifiez régulièrement la résistance du bracelet antistatique. Cette valeur doit être comprise entre 1 et 10 mégohms (Mohms).

- When handling any component that is subject to ESD damage and that is removed from the device, make sure the equipment end of your ESD wrist strap is attached to the ESD point on the chassis.

If no grounding strap is available, touch the exposed, bare metal of the device to ground yourself before handling the component.

- Avoid contact between the component that is subject to ESD damage and your clothing. ESD voltages emitted from clothing can damage components.
- When removing or installing a component that is subject to ESD damage, always place it component-side up on an antistatic surface, in an antistatic card rack, or in an antistatic bag (see [Figure 220 on page 395](#)). If you are returning a component, place it in an antistatic bag before packing it.

**Figure 220: Placing a Component into an Antistatic Bag**





**CAUTION:** ANSI/TIA/EIA-568 cables such as Category 5e and Category 6 can get electrostatically charged. To dissipate this charge, always ground the cables to a suitable and safe earth ground before connecting them to the system.

**Attention** Les câbles ANSI/TIA/EIA-568, par exemple Cat 5e et Cat 6, peuvent emmagasiner des charges électrostatiques. Pour évacuer ces charges, reliez toujours les câbles à une prise de terre adaptée avant de les raccorder au système.

## AC Power Electrical Safety Guidelines

The following electrical safety guidelines apply to AC-powered devices:

- Note the following warnings printed on the device:

**“CAUTION: THIS UNIT HAS MORE THAN ONE POWER SUPPLY CORD. DISCONNECT ALL POWER SUPPLY CORDS BEFORE SERVICING TO AVOID ELECTRIC SHOCK.”**

**“ATTENTION: CET APPAREIL COMPORTE PLUS D'UN CORDON D'ALIMENTATION. AFIN DE PRÉVENIR LES CHOCS ÉLECTRIQUES, DÉBRANCHER TOUT CORDON D'ALIMENTATION AVANT DE FAIRE LE DÉPANNAGE.”**

- AC-powered devices are shipped with a three-wire electrical cord with a grounding-type plug that fits only a grounding-type power outlet. Do not circumvent this safety feature. Equipment grounding must comply with local and national electrical codes.
- You must provide an external certified circuit breaker (2-pole circuit breaker or 4-pole circuit breaker based on your device) rated minimum 20 A in the building installation.
- The power cord serves as the main disconnecting device for the AC-powered device. The socket outlet must be near the AC-powered device and be easily accessible.
- For devices that have more than one power supply connection, you must ensure that all power connections are fully disconnected so that power to the device is completely removed to prevent electric shock. To disconnect power, unplug all power cords (one for each power supply).

## Power Cable Warning (Japanese)

**WARNING:** The attached power cable is only for this product. Do not use the cable for another product.

**注意**

附属の電源コードセットはこの製品専用です。  
他の電気機器には使用しないでください。

0477083

## AC Power Disconnection Warning



**WARNING:** Before working on the device or near power supplies, unplug all the power cords from an AC-powered device.

**Waarschuwing** Voordat u aan een frame of in de nabijheid van voedingen werkt, dient u bij wisselstroom toestellen de stekker van het netsnoer uit het stopcontact te halen.

**Varoitus** Kytke irti vaihtovirtalaitteiden virtajohto, ennen kuin teet mitään asennuspohjalle tai työskentelet virtalähteiden läheisyydessä.

**Avertissement** Avant de travailler sur un châssis ou à proximité d'une alimentation électrique, débrancher le cordon d'alimentation des unités en courant alternatif.

**Warnung** Bevor Sie an einem Chassis oder in der Nähe von Netzgeräten arbeiten, ziehen Sie bei Wechselstromeinheiten das Netzkabel ab bzw.

**Avvertenza** Prima di lavorare su un telaio o intorno ad alimentatori, scollegare il cavo di alimentazione sulle unità CA.

**Advarsel** Før det utføres arbeid på kabinettet eller det arbeides i nærheten av strømforsyningsenheter, skal strømledningen trekkes ut på vekselstrømsenheter.

**Aviso** Antes de trabalhar num chassis, ou antes de trabalhar perto de unidades de fornecimento de energia, desligue o cabo de alimentação nas unidades de corrente alternada.



**¡Atención!** Antes de manipular el chasis de un equipo o trabajar cerca de una fuente de alimentación, desenchufar el cable de alimentación en los equipos de corriente alterna (CA).

**Varning!** Innan du arbetar med ett chassi eller nära strömförsörjningsenheter skall du för växelströmsenheter dra ur nätsladden.

## DC Power Electrical Safety Guidelines

- A DC-powered device is equipped with a DC terminal block that is rated for the power requirements of a maximally configured device.
- For permanently connected equipment, a readily accessible disconnect device shall be incorporated external to the equipment.
- For pluggable equipment, the socket-outlet shall be installed near the equipment and shall be easily accessible.
- Be sure to connect the ground wire or conduit to a solid central office earth ground.
- A closed loop ring is recommended for terminating the ground conductor at the ground stud.
- Run two wires from the circuit breaker box to a source of 48 VDC.
- A DC-powered device that is equipped with a DC terminal block is intended only for installation in a restricted-access location. In the United States, a restricted-access area is one in accordance with Articles 110-16, 110-17, and 110-18 of the National Electrical Code ANSI/NFPA 70.

**NOTE:** Primary overcurrent protection is provided by the building circuit breaker. This breaker must protect against excess currents, short circuits, and earth grounding faults in accordance with NEC ANSI/NFPA 70.

- Ensure that the polarity of the DC input wiring is correct. Under certain conditions, connections with reversed polarity might trip the primary circuit breaker or damage the equipment.
- The marked input voltage of -48 VDC for a DC-powered device is the nominal voltage associated with the battery circuit, and any higher voltages are only to be associated with float voltages for the charging function.

- Because the device is a positive ground system, you must connect the positive lead to the terminal labeled **RTN**, the negative lead to the terminal labeled **-48 VDC**, and the earth ground to the device grounding points.

## DC Power Disconnection Warning



**WARNING:** Before performing any of the DC power procedures, ensure that power is removed from the DC circuit. To ensure that all power is off, locate the circuit breaker on the panel board that services the DC circuit, switch the circuit breaker to the OFF position, and tape the device handle of the circuit breaker in the OFF position.

**Waarschuwing** Voordat u een van de onderstaande procedures uitvoert, dient u te controleren of de stroom naar het gelijkstroom circuit uitgeschakeld is. Om u ervan te verzekeren dat alle stroom UIT is geschakeld, kiest u op het schakelbord de stroomverbreker die het gelijkstroom circuit bedient, draait de stroomverbreker naar de UIT positie en plakt de schakelaarhendel van de stroomverbreker met plakband in de UIT positie vast.

**Varoitus** Varmista, että tasavirtapiirissä ei ole virtaa ennen seuraavien toimenpiteiden suorittamista. Varmistaaksesi, että virta on KATKAISTU täysin, paikanna tasavirrasta huolehtivassa kojetaulussa sijaitseva suojakytkin, käännä suojakytkin KATKAISTU-asentoon ja teippaa suojakytkimen varsi niin, että se pysyy KATKAISTU-asennossa.

**Avertissement** Avant de pratiquer l'une quelconque des procédures ci-dessous, vérifier que le circuit en courant continu n'est plus sous tension. Pour en être sûr, localiser le disjoncteur situé sur le panneau de service du circuit en courant continu, placer le disjoncteur en position fermée (OFF) et, à l'aide d'un ruban adhésif, bloquer la poignée du disjoncteur en position OFF.

**Warnung** Vor Ausführung der folgenden Vorgänge ist sicherzustellen, daß die Gleichstromschaltung keinen Strom erhält. Um sicherzustellen, daß sämtlicher Strom abgestellt ist, machen Sie auf der Schalttafel den Unterbrecher für die Gleichstromschaltung ausfindig, stellen Sie den Unterbrecher auf AUS, und kleben Sie den Schaltergriff des Unterbrechers mit Klebeband in der AUS-Stellung fest.

**Avvertenza** Prima di svolgere una qualsiasi delle procedure seguenti, verificare che il circuito CC non sia alimentato. Per verificare che tutta l'alimentazione sia scollegata (OFF), individuare l'interruttore automatico sul quadro strumenti che alimenta il circuito

CC, mettere l'interruttore in posizione OFF e fissarlo con nastro adesivo in tale posizione.

**Advarsel** Før noen av disse prosedyrene utføres, kontroller at strømmen er frakoblet likestrømkretsen. Sørg for at all strøm er slått AV. Dette gjøres ved å lokalisere strømbryteren på brytertavlen som betjener likestrømkretsen, slå strømbryteren AV og teipe bryterhåndtaket på strømbryteren i AV-stilling.

**Aviso** Antes de executar um dos seguintes procedimentos, certifique-se que desligou a fonte de alimentação de energia do circuito de corrente contínua. Para se assegurar que toda a corrente foi DESLIGADA, localize o disjuntor no painel que serve o circuito de corrente contínua e coloque-o na posição OFF (Desligado), segurando nessa posição a manivela do interruptor do disjuntor com fita isoladora.

**¡Atención!** Antes de proceder con los siguientes pasos, comprobar que la alimentación del circuito de corriente continua (CC) esté cortada (OFF). Para asegurarse de que toda la alimentación esté cortada (OFF), localizar el interruptor automático en el panel que alimenta al circuito de corriente continua, cambiar el interruptor automático a la posición de Apagado (OFF), y sujetar con cinta la palanca del interruptor automático en posición de Apagado (OFF).

**Warning!** Innan du utför någon av följande procedurer måste du kontrollera att strömförsörjningen till likströmskretsen är bruten. Kontrollera att all strömförsörjning är BRUTEN genom att slå AV det överspänningsskydd som skyddar likströmskretsen och tejsa fast överspänningsskyddets omkopplare i FRÅN-läget.

## DC Power Grounding Requirements and Warning

An insulated grounding conductor that is identical in size to the grounded and ungrounded branch circuit supply conductors but is identifiable by green and yellow stripes is installed as part of the branch circuit that supplies the device. The grounding conductor is a separately derived system at the supply transformer or motor generator set.



**WARNING:** When you install the device, the ground connection must always be made first and disconnected last.

**Waarschuwing** Bij de installatie van het toestel moet de aardverbinding altijd het eerste worden gemaakt en het laatste worden losgemaakt.

**Varoitus** Laitetta asennettaessa on maahan yhdistäminen aina tehtävä ensiksi ja maadoituksen irti kytkeminen viimeiseksi.

**Avertissement** Lors de l'installation de l'appareil, la mise à la terre doit toujours être connectée en premier et déconnectée en dernier.

**Warnung** Der Erdanschluß muß bei der Installation der Einheit immer zuerst hergestellt und zuletzt abgetrennt werden.

**Avvertenza** In fase di installazione dell'unità, eseguire sempre per primo il collegamento a massa e disconnetterlo per ultimo.

**Advarsel** Når enheten installeres, må jordledningen alltid tilkobles først og frakobles sist.

**Aviso** Ao instalar a unidade, a ligação à terra deverá ser sempre a primeira a ser ligada, e a última a ser desligada.

**¡Atención!** Al instalar el equipo, conectar la tierra la primera y desconectarla la última.

**Warning!** Vid installation av enheten måste jordledningen alltid anslutas först och kopplas bort sist.

## DC Power Wiring Terminations Warning



**WARNING:** When stranded wiring is required, use approved wiring terminations, such as closed-loop or spade-type with upturned lugs. These terminations must be the appropriate size for the wires and must clamp both the insulation and conductor.

**Waarschuwing** Wanneer geslagen bedrading vereist is, dient u bedrading te gebruiken die voorzien is van goedgekeurde aansluitingspunten, zoals het gesloten-lus type of het grijperschop type waarbij de aansluitpunten omhoog wijzen. Deze aansluitpunten dienen de juiste maat voor de draden te hebben en dienen zowel de isolatie als de geleider vast te klemmen.

**Varoitus** Jos säikeellinen johdin on tarpeen, käytä hyväksyttyä johdinliitääntä, esimerkiksi suljettua silmukkaa tai kourumaista liitääntä, jossa on ylöspäin käännetyt kiinnityskorvat. Tällaisten liitääntöjen tulee olla kooltaan johtimiin sopivia ja niiden tulee puristaa yhteen sekä eristeen että johdinosan.

**Avertissement** Quand des fils torsadés sont nécessaires, utiliser des douilles terminales homologuées telles que celles à circuit fermé ou du type à plage ouverte avec cosses rebroussées. Ces douilles terminales doivent être de la taille qui convient aux fils et doivent être refermées sur la gaine isolante et sur le conducteur.

**Warnung** Wenn Litzenverdrahtung erforderlich ist, sind zugelassene Verdrahtungsabschlüsse, z.B. für einen geschlossenen Regelkreis oder gabelförmig, mit nach oben gerichteten Kabelschuhen zu verwenden. Diese Abschlüsse sollten die angemessene Größe für die Drähte haben und sowohl die Isolierung als auch den Leiter festklemmen.

**Avvertenza** Quando occorre usare trecce, usare connettori omologati, come quelli a occhio o a forcella con linguette rivolte verso l'alto. I connettori devono avere la misura adatta per il cablaggio e devono serrare sia l'isolante che il conduttore.

**Advarsel** Hvis det er nødvendig med flertrådede ledninger, brukes godkjente ledningsavslutninger, som for eksempel lukket sløyfe eller spadetype med oppoverbøyde kabelsko. Disse avslutningene skal ha riktig størrelse i forhold til ledningene, og skal klemme sammen både isolasjonen og ledaren.

**Aviso** Quando forem requeridas montagens de instalação eléctrica de cabo torcido, use terminações de cabo aprovadas, tais como, terminações de cabo em circuito fechado e planas com terminais de orelha voltados para cima. Estas terminações de cabo deverão ser do tamanho apropriado para os respectivos cabos, e deverão prender simultaneamente o isolamento e o fio condutor.

**¡Atención!** Cuando se necesite hilo trenzado, utilizar terminales para cables homologados, tales como las de tipo "bucle cerrado" o "espada", con las lengüetas de conexión vueltas hacia arriba. Estos terminales deberán ser del tamaño apropiado para los cables que se utilicen, y tendrán que sujetar tanto el aislante como el conductor.

**Varning!** När flertrådiga ledningar krävs måste godkända ledningskontakter användas, t.ex. kabelsko av slutet eller öppen typ med uppåtvänd tapp. Storleken på dessa kontakter måste vara avpassad till ledningarna och måste kunna hålla både isoleringen och ledaren fastklämda.

## Multiple Power Supplies Disconnection Warning



**WARNING:** The network device has more than one power supply connection. All connections must be removed completely to remove power from the unit completely.

**Waarschuwing** Deze eenheid heeft meer dan één stroomtoevoerverbinding; alle verbindingen moeten volledig worden verwijderd om de stroom van deze eenheid volledig te verwijderen.

**Varoitus** Tässä laitteessa on useampia virtalähdekytkentöjä. Kaikki kytkennät on irrotettava kokonaan, jotta virta poistettaisiin täysin laitteesta.

**Avertissement** Cette unité est équipée de plusieurs raccordements d'alimentation. Pour supprimer tout courant électrique de l'unité, tous les cordons d'alimentation doivent être débranchés.

**Warnung** Diese Einheit verfügt über mehr als einen Stromanschluß; um Strom gänzlich von der Einheit fernzuhalten, müssen alle Stromzufuhren abgetrennt sein.

**Avvertenza** Questa unità ha più di una connessione per alimentatore elettrico; tutte le connessioni devono essere completamente rimosse per togliere l'elettricità dall'unità.

**Advarsel** Denne enheten har mer enn én strømtilkobling. Alle tilkoblinger må kobles helt fra for å eliminere strøm fra enheten.

**Aviso** Este dispositivo possui mais do que uma conexão de fonte de alimentação de energia; para poder remover a fonte de alimentação de energia, deverão ser desconectadas todas as conexões existentes.

**¡Atención!** Esta unidad tiene más de una conexión de suministros de alimentación; para eliminar la alimentación por completo, deben desconectarse completamente todas las conexiones.

**Warning!** Denna enhet har mer än en strömförsörjningsanslutning; alla anslutningar måste vara helt avlägsnade innan strömtillförseln till enheten är fullständigt bruten.

## TN Power Warning



**WARNING:** The device is designed to work with a TN power system.

**Waarschuwing** Het apparaat is ontworpen om te functioneren met TN energiesystemen.

**Varoitus** Koje on suunniteltu toimimaan TN-sähkövoimajärjestelmien yhteydessä.

**Avertissement** Ce dispositif a été conçu pour fonctionner avec des systèmes d'alimentation TN.

**Warnung** Das Gerät ist für die Verwendung mit TN-Stromsystemen ausgelegt.

**Avvertenza** Il dispositivo è stato progettato per l'uso con sistemi di alimentazione TN.

**Advarsel** Utstyret er utfomet til bruk med TN-strømsystemer.

**Aviso** O dispositivo foi criado para operar com sistemas de corrente TN.

**¡Atención!** El equipo está diseñado para trabajar con sistemas de alimentación tipo TN.

**Varning!** Enheten är konstruerad för användning tillsammans med elkraftssystem av TN-typ.

## Agency Approvals for the QFX Series

### IN THIS SECTION

- [Compliance Statement for Argentina | 406](#)

The QFX Series complies with the following standards:

- Safety
  - CAN/CSA-C22.2 No. 60950-1 Safety of Information Technology Equipment
  - UL 62368-1 Audio/Video, Information and Communication Technology Equipment- Safety
  - IEC 62368-1: 2014 Audio/Video, Information and Communication Technology Equipment–Safety
  - IEC 60950-1: 2005/A2:2013 Information Technology Equipment -Safety (All country deviations): CB Scheme

- EN 60825-1 Safety of Laser Products - Part 1: Equipment Classification, Requirements and User's Guide
- Electromagnetic Compatibility (EMC)
  - EN 300 386 V1.6.1 (2012) Telecom Network Equipment–EMC requirements
  - EN 55024: 1998/A1:2001/A2:2003 Information Technology Equipment Immunity Characteristics
  - TEC/SD/DD/EMC-221–India EMC standard
  - EN 301 489-1 V1.92 (2011-09)–EMC and Radio spectrum Matters
  - EN 55024
  - CISPR 24
  - BSMI, Class A
  - CNS 13438
- Electromagnetic Interference (EMI)
  - FCC 47 CFR Part 15, Class A (2009) USA Radiated Emissions
  - EN 55022 Class A (2010) European Radiated Emissions
  - VCCI Class A:(2010) Japanese Emissions
  - BSMI CNS 13438 and NCC C6357 Class A Taiwan Radiated Emissions
  - AS/NZS CISPR 22:2009: Class A, Australian/New Zealand Radiated Emissions
- Immunity
  - EN 55024: 1998/A1:2001/A2:2003 Information Technology Equipment Immunity Characteristics
  - EN-61000-3-2 (2006) Power Line Harmonics
  - EN-61000-3-3 (2013) Power Line Voltage Fluctuations
  - EN-61000-4-2 (2009) Electrostatic Discharge
  - EN-61000-4-3 (2007) Radiated Immunity
  - EN-61000-4-4 (2012) Electrical Fast Transients
  - EN-61000-4-5 (2006) Surge
  - EN-61000-4-6 (2009) Immunity to Conducted Disturbances



- EN-61000-4-11 (2004) Voltage Dips and Sags

## Compliance Statement for Argentina

EQUIPO DE USO IDÓNEO.

# Compliance Statements for EMC Requirements for the QFX Series

### IN THIS SECTION

- [Canada | 406](#)
- [European Community | 407](#)
- [Israel | 408](#)
- [Japan | 408](#)
- [Korea | 408](#)
- [Taiwan | 409](#)
- [United States | 409](#)
- [Nonregulatory Environmental Standards | 409](#)

This topic describes the EMC requirements for the QFX Series.

## Canada

This Class A digital apparatus complies with Canadian ICES-003.

Cet appareil numérique de la classe A est conforme à la norme NMB-003 du Canada.

The Industry Canada label identifies certified equipment. This certification means that the equipment meets certain telecommunications network protective, operational, and safety requirements. Industry Canada does not guarantee the equipment will operate to the users' satisfaction.

Before installing this equipment, users should ensure that it is permissible to connect the equipment to the facilities of the local telecommunications company. The equipment must also be installed using an acceptable method of connection. In some cases, the inside wiring associated with a single line individual service may be extended by means of a certified connector assembly. The customer should be aware that compliance with the above conditions may not prevent degradation of service in some situations.

Repairs to certified equipment should be made by an authorized Canadian maintenance facility designated by the supplier. Any repairs or alterations made by the user to this equipment, or equipment malfunctions, may give the telecommunications company cause to request the user to disconnect the equipment.



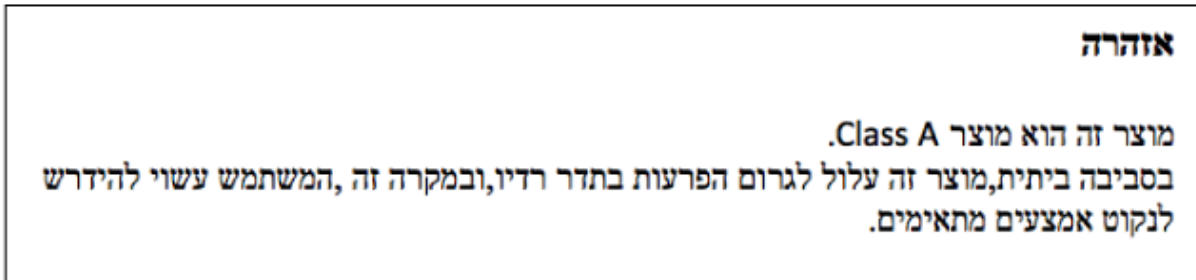
**CAUTION:** Users should not attempt to make electrical ground connections by themselves, but should contact the appropriate inspection authority or an electrician, as appropriate.

Users should ensure for their own protection that the electrical ground connections of the power utility, telephone lines, and internal metallic water pipe system, if present, are connected together. This precaution may be particularly important in rural areas.

## European Community

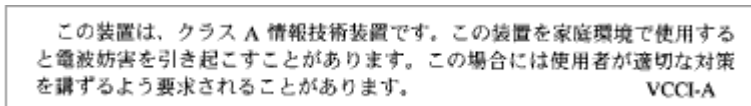
This is a Class A product. In a domestic environment this product may cause radio interference in which case the user may be required to take adequate measures.

## Israel



Translation from Hebrew–Warning: This product is Class A. In residential environments, the product may cause radio interference, and in such a situation, the user may be required to take adequate measures.

## Japan



The preceding translates as follows:

This is a Class A product. In a domestic environment this product may cause radio interference in which case the user may be required to take adequate measures.

VCCI-A

## Korea

이 기기는 업무용(A급) 전자파적합기기로서 판매자 또는 사용자는 이 점을 주의하시기 바라며, 가정외의 지역에서 사용하는 것을 목적으로 합니다.

Korean Class A Warning

g040913

The preceding translates as follows:

This equipment is Industrial (Class A) electromagnetic wave suitability equipment and seller or user should take notice of it, and this equipment is to be used in the places except for home.

## Taiwan

警告使用者：  
這是甲類的資訊產品，在居住的環境中使用時，可能會造成射頻干擾，在這種情況下，使用者會被要求採取某些適當的對策。

Chinese Class A warning

0600018

The preceding translates as follows:

This is Class A product. In a domestic environment this product may cause radio interference in which case the user may be required to take adequate measures.

## United States

The QFX Series device has been tested and found to comply with the limits for a Class A digital device, pursuant to Part 15 of the FCC Rules. These limits are designed to provide reasonable protection against harmful interference when the equipment is operated in a commercial environment. This equipment generates, uses, and can radiate radio frequency energy and, if not installed and used in accordance with the instruction manual, may cause harmful interference to radio communications. Operation of this equipment in a residential area is likely to cause harmful interference in which case the user will be required to correct the interference at his own expense.

## Nonregulatory Environmental Standards

These QFX Series product SKUs are Network Equipment Building System (NEBS) compliant:

- QFX3008-I
- QFX3600-I
- QFX3600

- QFX3500
- QFX5100
- QFX5110
- QFX5200-32C
- QFX10002-36Q and QFX10002-72Q
- QFX10008
- QFX10016

Those device product SKUs meet the following NEBS compliance standards:

- SR-3580 NEBS Criteria Levels (Level 3 Compliance)
- GR-1089-CORE, Issue 6: EMC and Electrical Safety—Generic Criteria for Network Telecommunications Equipment
  - The equipment is suitable for installation in locations where the National Electrical Code (NEC) applies.
  - The battery return connection is to be treated as an Isolated DC return (DC-I), as defined in GR-1089-CORE.
- GR-63-CORE: NEBS, Physical Protection
  - The equipment is suitable for installation as part of the Common Bonding Network (CBN).
  - The equipment is suitable for installation in a central office (CO).

#### RELATED DOCUMENTATION

| [Agency Approvals for the QFX Series | 404](#)

## QFX Series Compliance Statements for NEBS

- The equipment is suitable for installation as part of the Common Bonding Network (CBN).
- The equipment is suitable for installation in locations where the National Electrical Code (NEC) applies.

- The battery return connection is to be treated as an isolated DC return (that is, DC-I), as defined in GR-1089-CORE.
- You must provision a readily accessible device outside of the equipment to disconnect power. The device must also be rated based on local electrical code practice.

#### RELATED DOCUMENTATION

[Agency Approvals for the QFX Series | 404](#)

[Compliance Statements for EMC Requirements for the QFX10016](#)

## Compliance Statements for Environmental Requirements

Batteries in this product are not based on mercury, lead, or cadmium substances. The batteries used in this product are in compliance with EU Directives 91/157/EEC, 93/86/EEC, and 98/101/EEC. The product documentation includes instructional information about the proper method of reclamation and recycling.