

# QFX5110 Switch Hardware Guide

Published  
2024-07-31

Juniper Networks, Inc.  
1133 Innovation Way  
Sunnyvale, California 94089  
USA  
408-745-2000  
www.juniper.net

Juniper Networks, the Juniper Networks logo, Juniper, and Junos are registered trademarks of Juniper Networks, Inc. in the United States and other countries. All other trademarks, service marks, registered marks, or registered service marks are the property of their respective owners.

Juniper Networks assumes no responsibility for any inaccuracies in this document. Juniper Networks reserves the right to change, modify, transfer, or otherwise revise this publication without notice.

*QFX5110 Switch Hardware Guide*

Copyright © 2024 Juniper Networks, Inc. All rights reserved.

The information in this document is current as of the date on the title page.

## YEAR 2000 NOTICE

Juniper Networks hardware and software products are Year 2000 compliant. Junos OS has no known time-related limitations through the year 2038. However, the NTP application is known to have some difficulty in the year 2036.

## END USER LICENSE AGREEMENT

The Juniper Networks product that is the subject of this technical documentation consists of (or is intended for use with) Juniper Networks software. Use of such software is subject to the terms and conditions of the End User License Agreement ("EULA") posted at <https://support.juniper.net/support/eula/>. By downloading, installing or using such software, you agree to the terms and conditions of that EULA.

# Table of Contents

[About This Guide | ix](#)

1

## [Fast Track: Initial Installation](#)

[Fast Track to Rack Installation and Power | 2](#)

[Mount the Device by Using the JNP-4PST-RMK-1U-E Rack Mount Kit On a Square Hole Rack | 2](#)

[Connect to Power | 7](#)

[Onboard, Configure, and Monitor QFX5110 | 10](#)

2

## [Overview](#)

[QFX5110 System Overview | 12](#)

[QFX5110 Hardware Overview | 12](#)

[QFX5110 Hardware Models | 17](#)

[Understanding Hardware Redundancy of QFX5110 Components and Functionality | 19](#)

[QFX5110 Field-Replaceable Units | 19](#)

[QFX5110 Port Panels | 21](#)

[QFX5110-48S Port Panel | 21](#)

[QFX5110-32Q Port Panel | 24](#)

[QFX5110 Network Port LEDs | 28](#)

[QFX5110 Management Panel | 30](#)

[QFX5110 Management Panel Description | 31](#)

[QFX5110 Management Port LEDs | 32](#)

[QFX5110 Chassis Status LEDs | 33](#)

[QFX5110 Cooling System | 37](#)

[QFX5110 Cooling System and Airflow Description | 38](#)

[QFX5110 Fan Module LED | 43](#)

[QFX5110 Power System | 45](#)

QFX5110 AC Power Supply Description | 45

QFX5110 AC Power Specifications | 47

QFX5110 AC Power Cord Specifications | 48

QFX5110 AC Power Supply LEDs | 50

QFX5110 DC Power Supply Description | 51

QFX5110 DC Power Specifications | 54

QFX5110 DC Power Supply LEDs | 55

## **Site Planning, Preparation, and Specifications**

**QFX5110 Site Preparation Checklist | 58**

**QFX5110 Site Guidelines and Requirements | 60**

QFX5110 Environmental Requirements and Specifications | 60

General Site Guidelines | 61

Site Electrical Wiring Guidelines | 62

QFX5110 Chassis Grounding Cable and Lug Specifications | 63

QFX5110 Clearance Requirements for Airflow and Hardware Maintenance | 64

QFX5110 Chassis Physical Specifications | 65

QFX5110 Rack Requirements | 66

**QFX5110 Deployment in a Virtual Chassis or Virtual Chassis Fabric | 68**

Planning a Virtual Chassis Deployment using QFX Devices | 68

Virtual Chassis Fabric Hardware Overview | 75

Plan a Virtual Chassis Fabric Deployment | 76

**QFX5110 Network Cable and Transceiver Planning | 80**

Determining Transceiver Support for the QFX5110 | 80

Cable Specifications for QSFP+, QSFP28, and QSFP-DD Transceivers | 81

Understanding QFX Series Fiber-Optic Cable Signal Loss, Attenuation, and Dispersion | 83

Calculating Power Budget and Power Margin for Fiber-Optic Cables | 85

How to Calculate Power Budget for Fiber-Optic Cables | 85

| How to Calculate Power Margin for Fiber-Optic Cables | 86

## **QFX5110 Management Cable Specifications and Pinouts | 88**

| Cable Specifications for Console and Management Connections for the QFX Series | 88

| RJ-45 Management Port Connector Pinout Information | 89

| Console Port Connector Pinouts for the QFX Series | 90

| RJ-45 Port, SFP Port, SFP+ Port, QSFP+ Port, and QSFP28 Port Connector Pinout Information | 91

| USB Port Specifications for the QFX Series | 98

4

## **Initial Installation and Configuration**

### **QFX5110 Installation Overview | 100**

| Standalone Installation Overview | 100

| Virtual Chassis Fabric Installation Overview | 101

| QFX5110 Installation Safety Guidelines | 102

### **Unpacking and Mounting the QFX5110 | 103**

| Unpacking a QFX5110 | 103

| Register Products—Mandatory to Validate SLAs | 105

| Mounting a QFX5110 in a Rack | 105

| Before You Begin Rack Installation | 106

| Mount a QFX5110 in a Rack or Cabinet by Using the JNP-4PST-RMK-1U-E Rack Mount Kit | 107

### **Connecting the QFX5110 to External Devices | 118**

| Connect a Device to a Network for Out-of-Band Management | 118

| Connect a Device to a Management Console Using an RJ-45 Connector | 119

### **Connecting the QFX5110 to Power | 121**

| Connect the QFX5110 to Earth Ground | 121

| Alternate Method to Ground QFX5110-48S-DC and QFX5110-32Q-DC Systems | 123

| Connecting AC Power to a QFX5110 | 124

| Connecting DC Power to a QFX5110 | 127

### **Connecting the QFX5110 in a Virtual Chassis or Virtual Chassis Fabric | 132**

Connecting QFX5110 and QFX5100 Members in a QFX5110 Virtual Chassis | 133

Connecting QFX5110 in a QFX5110 Virtual Chassis Fabric | 134

**Configuring a QFX5110 | 136**

5

## **Maintaining Components**

**Maintaining QFX5110 Fan Modules | 141**

Removing a Fan Module from a QFX5110 | 141

Installing a Fan Module in a QFX5110 | 142

**Maintaining QFX5110 Power Supplies | 144**

Removing a Power Supply from a QFX5110 | 144

Installing a Power Supply in a QFX5110 | 146

**Removing and Installing Transceivers and Fiber-Optic Cables on QFX5110 | 148**

Remove a Transceiver | 148

Install a Transceiver | 151

Disconnect a Fiber-Optic Cable | 154

Connect a Fiber-Optic Cable | 155

How to Handle Fiber-Optic Cables | 156

**Powering Off a QFX5110 | 157**

**Removing a QFX5110 from a Rack | 159**

6

## **Troubleshooting Hardware**

**Troubleshooting the QFX5110 | 162**

QFX5120 Troubleshooting Resources Overview | 162

QFX Series Alarm Messages Overview | 163

Chassis Alarm Messages | 163

7

## **Contacting Customer Support and Returning the Chassis or Components**

**Contact Customer Support to Obtain a Return Material Authorization | 169**

**Returning the QFX5110 Chassis or Components | 170**

Locating the Serial Number on a QFX5110 Device or Component | 170

Listing the Chassis and Component Details Using the CLI | 171

Locating the Chassis Serial Number ID Label on a QFX5110 | 172

Locating the Serial Number ID Labels on FRU Components | 172

How to Return a Hardware Component to Juniper Networks, Inc. | 173

Guidelines for Packing Hardware Components for Shipment | 174

## 8

### **Safety and Compliance Information**

**General Safety Guidelines and Warnings | 178**

**Definitions of Safety Warning Levels | 179**

**Qualified Personnel Warning | 181**

**Warning Statement for Norway and Sweden | 181**

**Fire Safety Requirements | 182**

**Installation Instructions Warning | 183**

**Restricted Access Warning | 184**

**Ramp Warning | 185**

**Rack-Mounting and Cabinet-Mounting Warnings | 186**

**Grounded Equipment Warning | 190**

**Radiation from Open Port Apertures Warning | 190**

**Laser and LED Safety Guidelines and Warnings for the QFX Series | 192**

**Maintenance and Operational Safety Guidelines and Warnings | 195**

**General Electrical Safety Guidelines and Warnings | 200**

**Action to Take After an Electrical Accident | 202**

**Prevention of Electrostatic Discharge Damage | 202**

**AC Power Electrical Safety Guidelines | 204**

**AC Power Disconnection Warning | 205**

**DC Power Electrical Safety Guidelines | 206**

DC Power Disconnection Warning	207
DC Power Grounding Requirements and Warning	209
DC Power Wiring Sequence Warning	209
DC Power Wiring Terminations Warning	211
Multiple Power Supplies Disconnection Warning	212
TN Power Warning	213
QFX5110 Agency Approvals	214
Agency Approvals for the QFX Series	214
Compliance Statements for EMC Requirements for the QFX Series	216



# About This Guide

Use this guide to plan, install, perform initial software configuration, perform routine maintenance, and to troubleshoot QFX5110 switches.

After completing the installation and basic configuration procedures covered in this guide, refer to the Junos OS documentation for further software configuration.

# 1

CHAPTER

## Fast Track: Initial Installation

---

Fast Track to Rack Installation and Power | 2

Onboard, Configure, and Monitor QFX5110 | 10

---

# Fast Track to Rack Installation and Power

## SUMMARY

This procedure walks you through the most basic steps for installing your QFX5110 switch in a rack and connecting it to power.

## IN THIS SECTION

- [Mount the Device by Using the JNP-4PST-RMK-1U-E Rack Mount Kit On a Square Hole Rack | 2](#)
- [Connect to Power | 7](#)

You can mount the QFX5110 switches on a square or threaded hole four-post 19-in. racks using the JNP-4PST-RMK-1U-E rack mount kit (RMK). We'll walk you through the steps to install the QFX5110-32Q and QFX5110-48S switches in a four-post square hole rack using the JNP-4PST-RMK-1U-E RMK.

**Before you install the switch, review:**

- ["QFX5110 Site Guidelines and Requirements" on page 60.](#)
- [General Safety Guidelines and Warnings.](#)
- ["Unpacking a QFX5110" on page 103.](#)

## Mount the Device by Using the JNP-4PST-RMK-1U-E Rack Mount Kit On a Square Hole Rack

Ensure that you have the following tools and parts available:

- An ESD grounding strap—not provided.
- Number 2 Phillips (+) screwdriver—not provided
- A pair of front and rear mounting rails that attach to the rack posts—provided with the rack mount kit
- A pair of mounting brackets and 16 flat head M4 x 6mm Phillips screws. These brackets attach to the device if not pre-installed—provided with the rack mount kit

To mount the device on four posts in a rack by using the JNP-4PST-RMK-1U-E rack mount kit:

1. Wrap and fasten the ESD grounding strap to your bare wrist and then connect the other end of the strap to the ESD point on the device.
2. Assemble the mounting rails.
  - a. Slide the rear floating bracket into the front bracket. See [Figure 1 on page 3](#).

**Figure 1: Assemble the Mounting Rails**

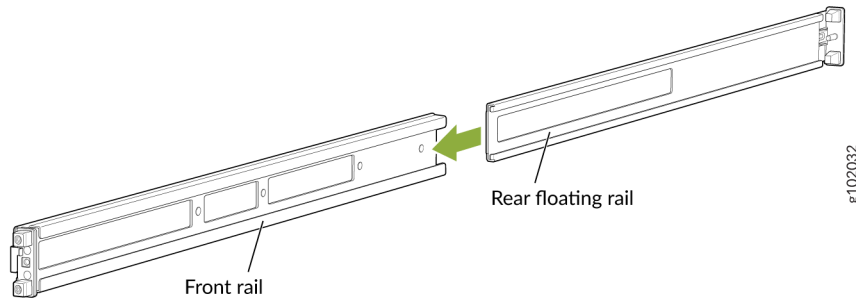

- b. Mounting rails assembled. See [Figure 2 on page 3](#).

**Figure 2: Front and Rear Rails Assembled**

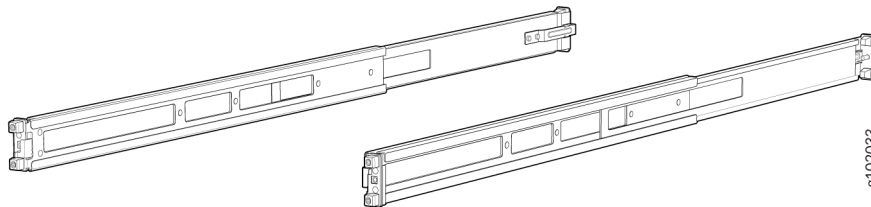

3. Attach the mounting rails to the rack.
  - a. Align the guide blocks of the rear mounting rails with the rear-post holes. Pull the rear mounting rails toward the front of the rack to lock the rails in place. You will hear a click sound when the latch locks into the corresponding rack holes. See [Figure 3 on page 4](#).

**Figure 3: Install the Rear Floating Rails**

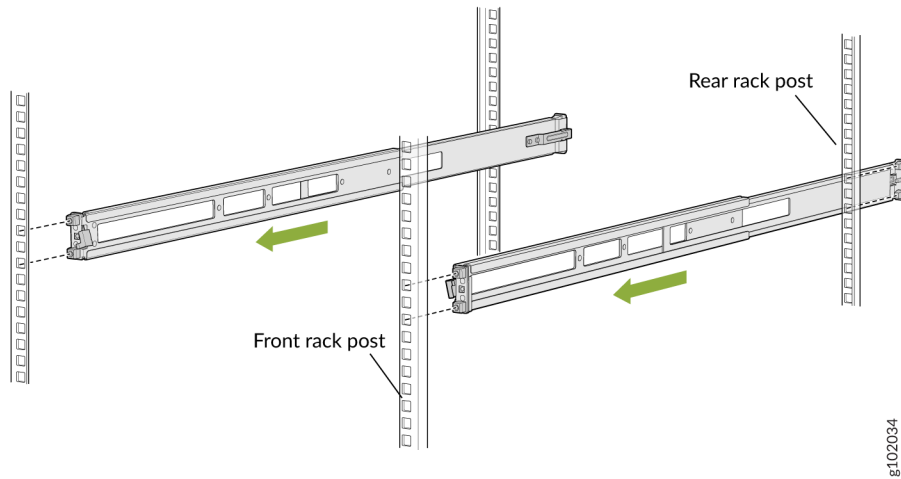

- b. Move the latch lock on the front mounting rails to open position, slide the front mounting rails, and insert the guide blocks into the front rack posts. See [Figure 4 on page 4](#).

**Figure 4: Install the Front Mounting Rails**

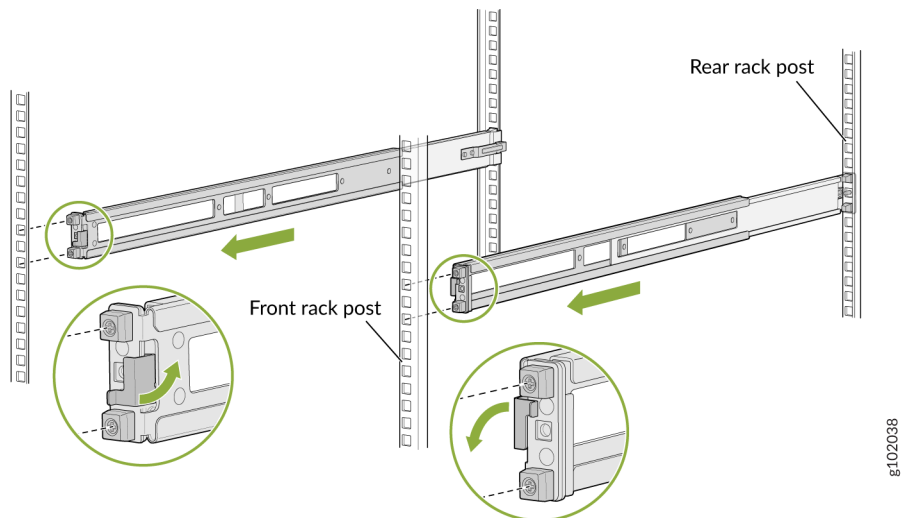

- c. Push the lock latch to the locked position. See [Figure 5 on page 5](#).

**Figure 5: Front Mounting Rails Lock Latch**

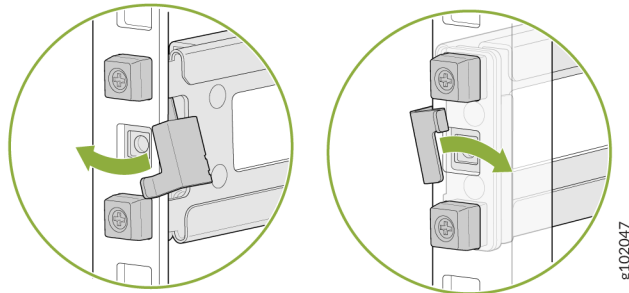

- d. Visually ensure that the front and rear latches are locked into place on the mounting rails. See [Figure 6 on page 5](#).

**Figure 6: Mounting Rails Installed and Locked**

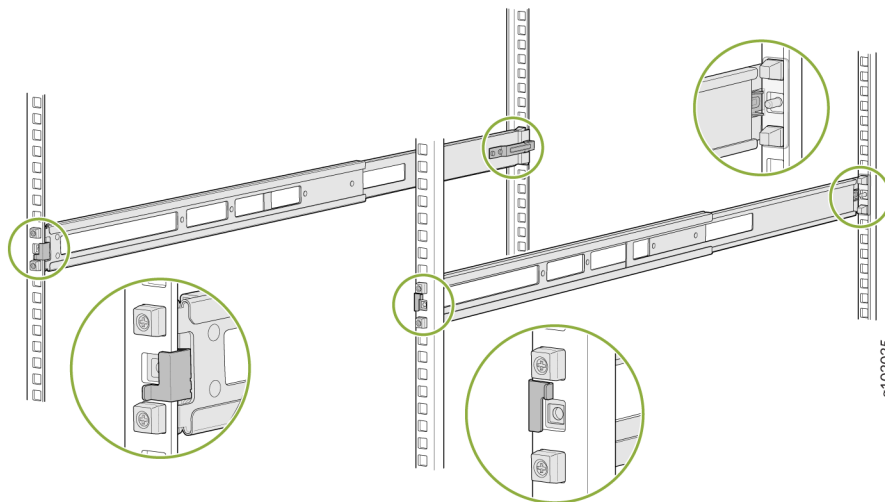

4. Attach mounting brackets to the device if not pre-installed. If your device already has the mounting brackets pre-installed than skip this step and move to the next step.
  - a. Align the holes on the mounting bracket with the screw holes on the side panel of the chassis.
  - b. Insert the flat head M4 x 6mm Phillips screws to attach the mounting bracket into the aligned holes on the chassis (see [Figure 7 on page 6](#)). Tighten the screws.

**Figure 7: Attach the Mounting Brackets to the Device**

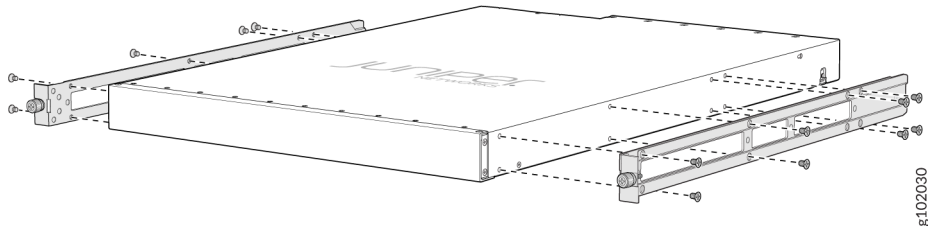

5. Position the device in such a manner that the **AIR OUT** labels on components are next to the hot aisle.
6. Grasp both sides of the device, lift it, and position the device such that the mounting rails slide into the channels of the mounting brackets. See [Figure 8 on page 6](#).

**Figure 8: Slide the Device into the Rack**

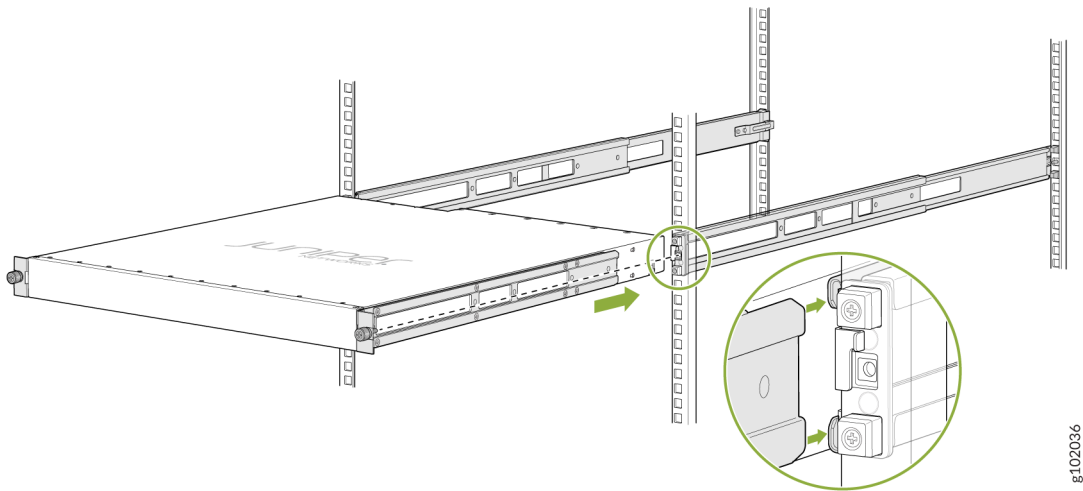

7. Tighten the two thumbscrews to secure the device. See [Figure 9 on page 7](#).

Figure 9: Tighten the Thumb Screws

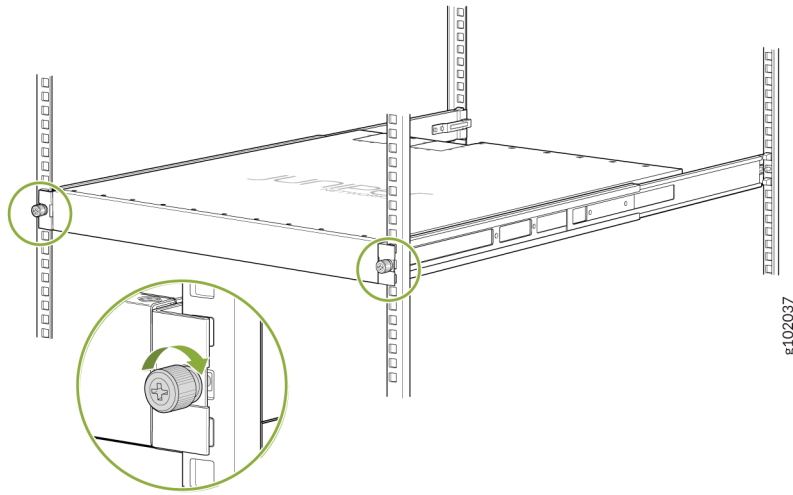

## Connect to Power

### IN THIS SECTION

- [Ground the QFX5110 Switch | 7](#)
- [Connect the Power Cord and Power On the QFX5110 Switch | 8](#)

### Ground the QFX5110 Switch

To ground the QFX5110 switch:

1. Wrap and fasten one end of the electrostatic discharge (ESD) cable grounding strap around your bare wrist, and connect the other end to a site ESD point.
2. Connect one end of the grounding cable to a proper earth ground, such as the rack in which the switch is mounted.
3. Place the grounding lug that is attached to the grounding cable over the protective earthing terminal.
4. Secure the grounding lug to the protective earthing terminal with two screws and washers. See [Figure 10 on page 8](#).



Figure 10: Connecting a Grounding Cable to a QFX5110

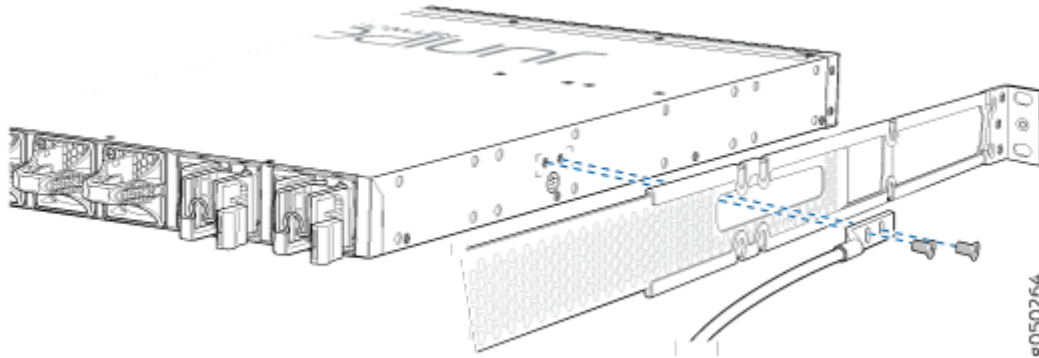

5. Dress the grounding cable and ensure that it does not touch or block access to other device components and that it does not drape where people could trip over it.

## Connect the Power Cord and Power On the QFX5110 Switch

To connect the power cord:

1. Attach the grounding strap to your bare wrist and to a site ESD point.
2. Ensure that the power supplies are fully inserted in the chassis and the latches are secure. If only one power supply is installed, ensure that a blank cover panel is installed over the second power supply slot.
3. Locate the power cord or cords shipped with the switch; the cords have plugs appropriate for your geographical location. See "[QFX5110 AC Power Specifications](#)" on page 47.



**WARNING:** Ensure that the power cord does not block access to device components or drape where people can trip on it.

4. Connect each power supply to the power sources. Insert the coupler end of the power cord into the AC power cord inlet on the AC power supply faceplate.
5. Push the power cord retainer onto the power cord (see [Figure 11 on page 9](#)).

Figure 11: Connecting an AC Power Cord to an AC Power Supply in a QFX5110

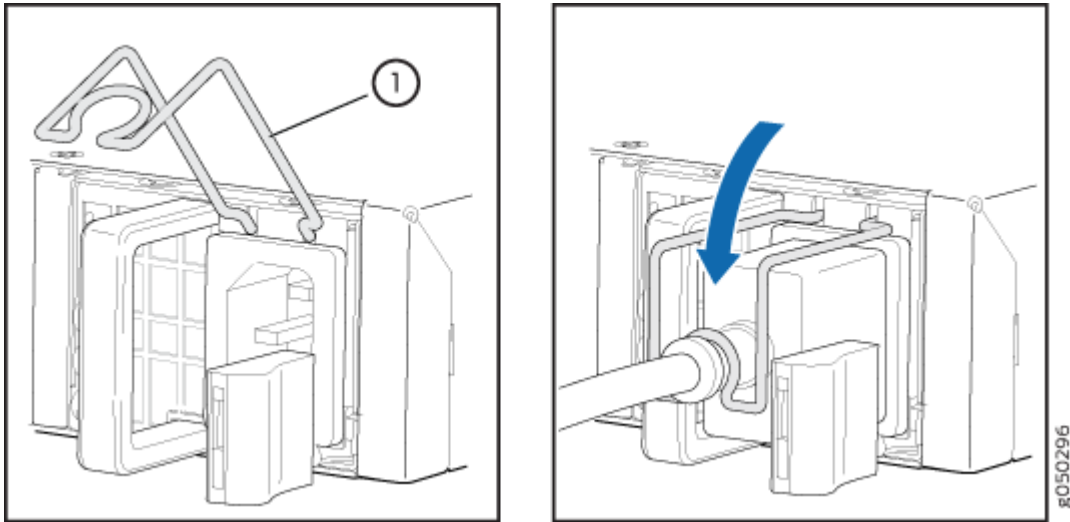

1– Power cord retainer

6. If the AC power source outlet has a power switch, set it to the off (O) position.

**NOTE:** The switch powers on as soon as power is provided to the power supply. There is no power switch on the device.

7. Insert the power cord plug into an AC power source outlet.
8. If the AC power source outlet has a power switch, set it to the on (I) position.
9. Verify that the AC and DC LEDs on each power supply are lit green.

If the amber fault LED is lit, remove power from the power supply, and replace the power supply (see ["Removing a Fan Module from a QFX5110" on page 141](#)). Do not remove the power supply until you have a replacement power supply ready: the power supplies or a blank cover panel must be installed in the switch to ensure proper airflow.



**CAUTION:** Replace a failed power supply with a blank panel or new power supply within one minute of removal to prevent chassis overheating.

# Onboard, Configure, and Monitor QFX5110

## SUMMARY

This topic provides you with pointers to onboard, configure, and monitor QFX5110 switches using Juniper Apstra or CLI (configure only).

You can use Juniper Apstra to onboard, configure, and monitor the QFX5110 switch. See [Table 1 on page 10](#) for more information.

**Table 1: Onboard, Configure, and Monitor QFX5110 Using Juniper Apstra**

If You Want To	Then
Install and configure Juniper Apstra	See <a href="#">Juniper Apstra Quick Start Guide</a>
Use Juniper Apstra	See <a href="#">Juniper Apstra User Guide</a>
See all documentation available for Juniper Apstra	See <a href="#">Juniper Apstra Documentation</a>

You can configure the QFX5110 switch using the CLI. See [Table 2 on page 10](#) for more information.

**Table 2: Configure QFX5110 Using the CLI**

If You Want To	Then
Customize the basic configuration	See <a href="#">"Configuring a QFX5110" on page 136</a>
Configure supported software features on QFX5110	See <a href="#">Software Documentation</a>
Stay up-to-date about new and changed features, and known and resolved issues	See <a href="#">Junos OS Release Notes</a>

# 2

CHAPTER

## Overview

---

[QFX5110 System Overview](#) | 12

[QFX5110 Port Panels](#) | 21

[QFX5110 Management Panel](#) | 30

[QFX5110 Cooling System](#) | 37

[QFX5110 Power System](#) | 45

---

# QFX5110 System Overview

## IN THIS SECTION

- [QFX5110 Hardware Overview | 12](#)
- [QFX5110 Hardware Models | 17](#)
- [Understanding Hardware Redundancy of QFX5110 Components and Functionality | 19](#)
- [QFX5110 Field-Replaceable Units | 19](#)

## QFX5110 Hardware Overview

### IN THIS SECTION

- [Benefits of QFX5110 | 12](#)
- [QFX5110 Models Overview | 13](#)
- [QFX5110-48S Hardware | 15](#)
- [QFX5110-32Q Hardware | 16](#)
- [System Software | 16](#)

The QFX5110 line of switches delivers low latency, flexible deployment options, and rich automation features. QFX5110 Switches build a strong underlay foundation for flexible, high-performance, standards-based fabrics and routing that improve network reliability and agility.

This topic covers:

### Benefits of QFX5110

#### Flexible fabric support

QFX5110 offers multiple fabric options to fit your desired network architecture:

- Virtual Chassis (VC), with up to 10 members

- Virtual Chassis Fabric (VC), which offers a single pane management for up to 20 nodes
- MC-LAG, which provides dual-homing with reduced complexity related to STP
- Junos Fusion Datacenter, where QFX5110 can operate as a satellite leaf node for 1 Gigabit, 10 Gigabit, 40 Gigabit, or 100 Gigabit connectivity

**Overlay options** QFX5110 provides L2 and L3 VXLAN gateway support that works in conjunction with a robust EVPN control plane to efficiently manage your virtualized workloads. Another option, OVSDB-VXLAN can be introduced to stitch virtualized and physical workloads.

**High density and low latency applications** Powered with high density 10 Gigabit or 40 Gigabit network ports and four 100G uplinks, the QFX5110 delivers 1.76 Tbps of throughput and a low latency of 550 nS. Your legacy applications continue to be supported by 100 Mbps or 1 Gigabit copper SFP transceivers.

## QFX5110 Models Overview

The QFX5110 line of switches offers two compact 1 U models that are ideal for top-of-rack, QFX Virtual Chassis, or Virtual Chassis Fabric (VCF) deployments, the 48-port QFX5110-48S and the 32-port QFX5110-32Q. Performance of the control plane running on all the QFX5110 switches is enhanced by the 1.8-Ghz quad-core Intel CPU with 16 GB of memory and 64 GB of solid-state drive (SSD) storage. Both models offer flexible port configurations of 1-Gigabit Ethernet, 10-Gigabit Ethernet, 40-Gigabit Ethernet, and 100-Gigabit Ethernet.

Both models can be ordered with either ports-to-FRUs or FRUs-to-ports airflow and with AC or DC power supplies.

The QFX5110-32Q can be used as:

- A standalone switch (Junos OS Release 17.2R1 and later).
- A primary, backup, or line card in a QFX5110 Virtual Chassis (Junos OS Release 17.3R1 and later).

A QFX5110 Series Virtual Chassis allows you to connect up to 10 QFX5110 or supported QFX5100 switches into one logical device and manage the device as a single chassis using a ring topology. The following QFX5100 switches are supported in a QFX5110 Virtual Chassis:

- QFX5100-24Q
- QFX5100-48S
- QFX5100-96S

For a QFX5100 switch to participate in a QFX5110 Virtual Chassis, the switch must have the same software version and image installed as the software running on the QFX5110 switches in the Virtual Chassis. You do not need to configure mixed mode. In a QFX5110 Virtual Chassis, we recommend to use QFX5110 switches in the primary and backup Routing Engine roles, and QFX5100 switches only in the linecard role.

- A spine or leaf device in a QFX5110 VCF (Junos OS Release 17.3R1 and later).

VCF uses QFX Virtual Chassis technology to interconnect multiple devices into a single logical device and manage that device as a single logical device inside of a fabric architecture. You can configure up to a total of 20 QFX5110 or QFX5100 devices in a VCF. Out of the 20 total devices, you can configure a maximum of 4 spine devices. You can use these models in any combination as leaf devices:

- QFX5100-24Q
- QFX5100-48S
- QFX5100-48T (Junos OS Release 17.3R2 and later)
- QFX5100-96S
- QFX5110-48S

**NOTE:** If only QFX5110-48S switches are available, cable and configure the switches as a QFX5110 Virtual chassis.

**NOTE:** Unlike a QFX5100 VCF, EX4300 switches are not supported in the QFX5110 VCF.

The QFX5110-48S can be used as:

- A standalone switch (Junos OS Release 15.1X53-D210 and later).
- A primary, backup, or line card in a QFX5110 Virtual Chassis (Junos OS Release 17.3R1 and later).

A QFX5110 Series Virtual Chassis allows you to connect up to 10 QFX5110 or supported QFX5100 switches into one logical device and manage the device as a single chassis using a ring topology. The following QFX5100 switches are supported in a QFX5110 Virtual Chassis:

- QFX5100-24Q
- QFX5100-48S
- QFX5100-96S

For a QFX5100 switch to participate in a QFX5110 Virtual Chassis, the switch must have the same software version and image installed as the software running on the QFX5110 switches in the Virtual Chassis. You do not need to configure mixed mode. In a QFX5110 Virtual Chassis, we recommend to use QFX5110 switches in the primary and backup Routing Engine roles, and QFX5100 switches only in the line card role.

- A leaf device in a QFX5110 VCF (Junos OS Release 17.3R1 and later).

VCF uses QFX Virtual Chassis technology to interconnect multiple devices into a single logical device and manage that device as a single logical device inside of a fabric architecture. You can configure up to a total of 20 QFX5110 devices in a QFX5110 VCF. Use QFX5110-32Q as the spine devices. You can use these models in any combination as leaf devices:

- QFX5100-24Q
- QFX5100-48S
- QFX5100-48T (Junos OS Release 17.3R2 and later)
- QFX5100-96S
- QFX5110-48S

**NOTE:** If only QFX5110-48S switches are available, cable and configure the switches as a QFX5110 Virtual chassis.

- A satellite device in a Junos Fusion Provider Edge system (Junos OS 18.1R2 and later)

**NOTE:** The QFX5110-48S does not support channelized ports in a Junos Fusion environment.

## QFX5110-48S Hardware

As shown in [Figure 12 on page 16](#), the QFX5110-48S is a 10-Gigabit Ethernet enhanced small form-factor pluggable plus (SFP+) switch with 48 SFP+ ports and four 100-Gbps quad small form-factor (QSFP) pluggable solution (QSFP28) ports. Each SFP+ port (**0** through **47**) can operate as a native 10-Gigabit Ethernet port or a 1-Gigabit Ethernet port when 1-Gigabit Ethernet optics are inserted.

Each QSFP28 port (**48** through **51**) can operate as a native 100-Gigabit Ethernet port, a native 40-Gigabit Ethernet port, or as 4 independent 10-Gigabit ports when using breakout cables. The four QSFP28 ports can be used as either access ports or as uplinks. The QFX5110-48S provides an aggregate throughput of 960 Gbps. The QFX5110-48S has a 1 U form factor and comes standard with redundant fans and redundant power supplies.



**Figure 12: QFX5110-48S Port Panel**

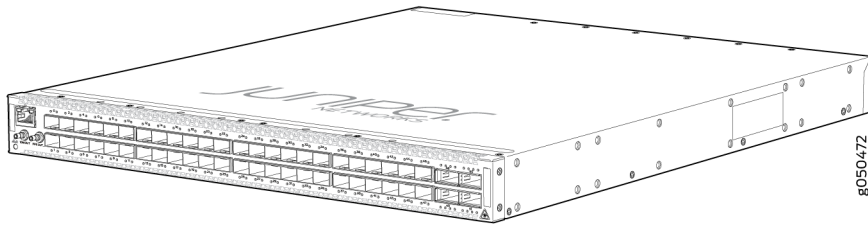

## QFX5110-32Q Hardware

As shown in [Figure 13 on page 16](#), the QFX5110-32Q is a flexible configuration switch allowing either 32 ports of 40-Gigabit Ethernet quad small form-factor pluggable plus (QSFP+) or 20 ports of QSFP+ and 4 ports of high-density 100-Gigabit Ethernet quad small form-factor pluggable solution (QSFP28). Each QSFP+ port can operate as a native 40-Gigabit Ethernet port, or as four independent 10-Gigabit Ethernet ports when using breakout cables. The four QSFP28 ports are available either as access ports or as uplinks.

The QFX5110-32Q can be channelized using one of the available system modes. For full details on the different port channelization modes, see "[QFX5110-32Q Port Panel](#)" on [page 24](#). The QFX5110-32Q switch provides an aggregate throughput of 2.56 Tbps.

**Figure 13: QFX5110-32Q Port Panel**

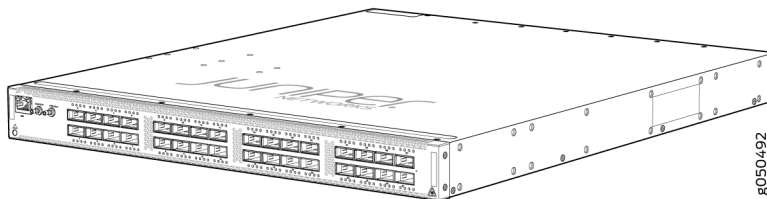

## System Software

QFX Series devices use the Junos operating system (OS), which is installed on a QFX5110 switch's 64-GB internal solid-state flash drive. The same Junos OS code base that runs on QFX5110 switches also runs on all Juniper Networks EX Series switches, and M Series, MX Series, and T Series routers.

The QFX5110-48S switch is supported on Junos OS Release 15.1X53-D210 and later; the QFX5110-32Q is supported on Junos OS 17.2R1 and later.

QFX5110 switches employ the security feature, Secure Boot, which is based on the UEFI 2.4 standard. The BIOS has been hardened and serves as a core root of trust. The BIOS updates, the bootloader, and the kernel are cryptographically protected. No action is required to implement Secure Boot.

If a premium or advanced feature is configured on the QFX5110 without a valid license, an alarm is raised and system log (syslog) messages are generated. For more information on licensing, see <https://www.juniper.net/documentation/us/en/software/license/juniper-licensing-user-guide/topics/concept/licenses-for-qfx.html>.

For more information about which features are supported on QFX Series devices, see [Feature Explorer](#).

You manage the switch using the Junos OS command-line interface (CLI), accessible through the console and out-of-band management ports on the device.

## SEE ALSO

[Virtual Chassis Fabric Hardware Documentation](#)

*Virtual Chassis Fabric Overview*

## QFX5110 Hardware Models

The QFX5110 switches have 32 or 48 port configurations. Both switches are available with either AC or DC power supply and with either airflow-in or airflow-out cooling. All models of the QFX5110, except the QFX5110-32Q\_CHAS, ship with two power supplies and five fans installed by default.

[Table 3 on page 17](#) lists the ordering numbers for QFX5110 hardware-only product SKUs.

**Table 3: QFX5110 Hardware-only Product Numbers**

Product Numbers	Ports	Power Supply	Airflow
QFX5110-48S-AFO	48 SFP+ 4 QSFP28	AC	Air Out (ports-to-FRUs)
QFX5110-48S-AFI	48 SFP+ 4 QSFP28	AC	Air In (FRUs-to-ports)

Table 3: QFX5110 Hardware-only Product Numbers (Continued)

Product Numbers	Ports	Power Supply	Airflow
QFX5110-48S-DC-AFO	48 SFP+ 4 QSFP28	DC	Air Out (ports-to-FRUs)
QFX5110-48S-DC-AFI	48 SFP+ 4 QSFP28	DC	Air In (FRUs-to-ports)
QFX5110-32Q-AFO	32 QSFP+ 4 QSFP28	AC	Air Out (ports-to-FRUs)
QFX5110-32Q-AFI	32 QSFP+ 4 QSFP28	AC	Air In (FRUs-to-ports)
QFX5110-32Q-DC-AFO	32 QSFP+ 4 QSFP28	DC	Air Out (ports-to-FRUs)
QFX5110-32Q-DC-AFI	32 QSFP+ 4 QSFP28	DC	Air In (FRUs-to-ports)
QFX5110-32Q-CHAS	32 QSFP+ 4 QSFP28	Order PSUs separately.	Fan modules are not shipped by default. Order fan modules separately.



**CAUTION:** Mixing different types (AC and DC) of power supplies in the same chassis is not supported. Mixing different airflow modules in the same chassis is not supported.

## Understanding Hardware Redundancy of QFX5110 Components and Functionality

The following hardware components provide redundancy on a QFX5110:

- **Power supplies**—The QFX5110 can operate with one power supply. However, all QFX5110 switches, except the QFX5110-32Q-CHAS, ship with two power supplies preinstalled for redundancy.. Each power supply provides power to all components in the switch. If two power supplies are installed, the two power supplies provide full power redundancy to the device. If one power supply fails or is removed, the second power supply takes over the electrical load without interruption.

To provide power redundancy to the system, both power supplies must be installed. Connect power source feed A to one power supply and power source feed B to the second power supply.



**CAUTION:** Do not connect feed A and feed B to the same power supply input terminal.

- **Cooling system**—All QFX5110 switches, except the QFX5110-32Q-CHAS, ship with five fan modules installed. If a fan module fails and is unable to keep the QFX5110 within the desired temperature thresholds, chassis alarms occur and the QFX5110 can shut down.

### SEE ALSO

[QFX5110 Power System | 45](#)

## QFX5110 Field-Replaceable Units

Field-replaceable units (FRUs) are components that you can replace at your site. The QFX5110 FRUs are hot-insertable and hot-removable: you can remove and replace one of them without powering off the switch or disrupting the switching function.



**CAUTION:** Replace a failed power supply with a blank panel or new power supply within one minute of removal to prevent chassis overheating. The switch continues to operate with only one power supply running. Replace a failed fan module with a new fan module within one minute of removal to prevent chassis overheating. Do not operate the switch with missing FRUs for longer than one minute.

Table 4 on page 20 lists the FRUs for the QFX5110 and actions to take before removing them.

**Table 4: FRUs in a QFX5110**

FRU	Required Action
Power supplies	None.
Fan modules	None.
Optical transceivers	None. We recommend that you disable the interface using the <b>set interfaces <i>interface-name</i> disable</b> command before you remove the transceiver. See " <a href="#">Remove a Transceiver</a> " on page 148.

**NOTE:** If you have a Juniper Care service contract, you can register any addition, change, or upgrade of hardware components at <https://www.juniper.net/customers/support/tools/updateinstallbase/>. Failure to do so can result in significant delays if you need replacement parts. This note does not apply if you replace existing components with the same type of component.

## SEE ALSO

[Maintaining QFX5110 Fan Modules | 141](#)

[Maintaining QFX5110 Power Supplies | 144](#)

[Removing and Installing Transceivers and Fiber-Optic Cables on QFX5110 | 148](#)

## RELATED DOCUMENTATION

[QFX5110 Management Panel | 30](#)

[QFX5110 Port Panels | 21](#)

# QFX5110 Port Panels

## IN THIS SECTION

- [QFX5110-48S Port Panel | 21](#)
- [QFX5110-32Q Port Panel | 24](#)
- [QFX5110 Network Port LEDs | 28](#)

## QFX5110-48S Port Panel

### IN THIS SECTION

- [Switch Overview | 21](#)
- [Network Ports | 22](#)
- [Channelizing Interfaces | 23](#)
- [Virtual Chassis and Virtual Chassis Fabric | 23](#)

The port panel of the QFX5110-48S is primarily comprised of 48 small form-factor pluggable plus (SFP+) and 4 quad small form-factor pluggable solution (QSFP28) ports. It also provides a central location for the Precision Time Protocol (PTP) connections to a grandmaster clock.

This topic describes:

### Switch Overview

The port panel of the QFX5110-48S supports 48 logical 10-GbE ports when operating as a standalone switch. These data ports (**0** through **47**) support either 1-Gbps or 10-Gbps SFP+ transceivers. You can also use SFP+ DAC cables and 10-Gbps active optical cables (AOC) in any access port. Starting in Junos OS Release 18.3R1, the 10-GbE ports also support 100 Mbps.

The remaining 4 QSFP28 ports (**48** through **51**) support speeds of 40 GbE or 100 GbE. Each port can be configured as an independent 100-GbE port or as an independent 40-GbE port. These port are usually used as uplinks or Virtual Chassis Ports (VCP) on QFX5110 Virtual Chassis or Virtual Chassis Fabric

(VCF). In 40-GbE mode, these ports can be channelized using QSFP+ to SFP+ DAC breakout (DACBO) cables.

Figure 14 on page 22 shows the port panel of the QFX5110-48S.

Figure 14: QFX5110-48S Port Panel

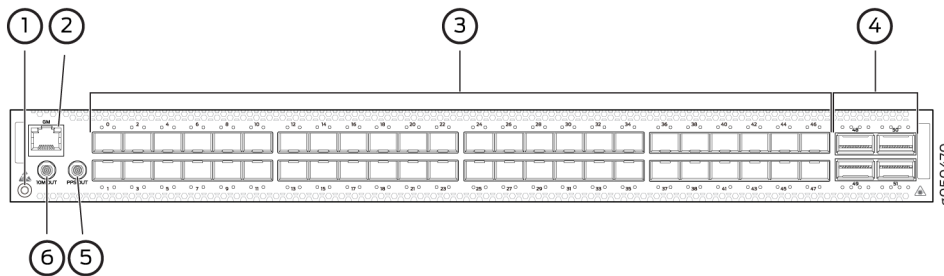

1– Electrostatic discharge (ESD) terminal	4– 4 QSFP28 ports
2– RJ-45 connection to grandmaster clock	5– Output clock at 10 Mhz
3– 48 SFP+ ports	6– 1 pulse per second (PPS) output connection

## Network Ports



**CAUTION:** When you use the latest OEM part number FCLF8521P2BTL (printed on the transceiver label), you can install 1GbE transceivers (such as QFX-SFP-1GE-T) in any port with no restrictions. The same applies for devices that support 10GbE copper transceivers. However, if you are using the older OEM part number SP7041-M1-JN (not shipped in last 3+ years) instead, do not install 1GbE copper transceivers (such as QFX-SFP-1GE-T) directly above or below another 1GbE copper transceiver. Use only the top row or bottom row to avoid damage to the device caused when the transceivers are installed above or below each other.

The QFX5110-48S device ports (**0 to 47**) support:

- 10-Gbps SFP+ transceivers
- 1-Gbps SFP transceivers
- SFP+ direct attach copper (DAC) cables
- SFP+ active optical cables (AOC)

The QFX5110-48S uplink ports (**48 to 51**) support:

- 100-Gbps QSFP28 transceivers

- 40-Gbps QSFP+ transceivers
- 100-Gbps AOC
- 40-Gbps AOC (Junos OS 18.3R1 and later)
- 100-Gbps QSFP28 DAC cables
- 40-Gbps QSFP+ DAC cables
- 40-Gbps QSFP+ to SFP+ DACBO cables (40-Gbps breaks out to 10-Gbps for copper connections)
- 40-Gbps AOCBO cables (40-Gbps breaks out to 10-Gbps for fiber connections)

## Channelizing Interfaces

For downstream traffic, the QFX5110-48S has 4 physical or 16 logical ports that can be used for port channelization. The default 100-Gigabit Ethernet ports can be configured as 40-Gigabit Ethernet, and in this configuration can either operate as dedicated 40-Gigabit Ethernet ports or can be channelized to 4 independent 10-Gigabit Ethernet ports using copper or fiber breakout cables.

To channelize the ports, manually configure the port speed using the `set chassis fpc slot-number port port-number channel-speed speed` command, where the speed can be set to 10-Gigabit Ethernet, 40-Gigabit Ethernet, or 100-Gigabit Ethernet. The ports do not support auto-channelization.

## Virtual Chassis and Virtual Chassis Fabric

To connect QFX5110 switches as members in a QFX5110 Virtual Chassis, you need a pair of dedicated ports on each switch and cables that link each member in the Virtual Chassis into a ring topology. Each member in the ring has at least one direct Virtual Chassis port (VCP) connection to an upstream and downstream member. QFX5110 switches are recommended in the primary, backup, or line card role. You may only mix QFX5100 members with QFX5110 members in a QFX5110 Virtual Chassis; no other QFX Series or EX Series switches are supported. See ["Connecting QFX5110 and QFX5100 Members in a QFX5110 Virtual Chassis" on page 133](#) for a diagram of cabling QFX5110 switches in a ring topology.

To connect a QFX5110 switch as a spine or leaf device in a Virtual Chassis Fabric (VCF), you need a pair of dedicated ports and cables that link each spine device and leaf device in the VCF. All spine devices have at least one direct VCP connection to each leaf device in the VCF. See ["Connecting QFX5110 in a QFX5110 Virtual Chassis Fabric" on page 134](#) for a cabling diagram.



## QFX5110-32Q Port Panel

### IN THIS SECTION

- [Switch Overview | 24](#)
- [Network Ports | 25](#)
- [Channelizing Interfaces | 25](#)
- [Virtual Chassis and Virtual Chassis Fabric | 27](#)

The port panel of the QFX5110-32Q primarily comprises 28 quad small form-factor pluggable plus (QSFP+) ports and 4 quad small form-factor pluggable solution (QSFP28) ports. The mixture of QSFP+ and QSFP28 ports allows for flexible configuration as either all 40-Gigabit Ethernet ports or a mixture of 40-Gigabit Ethernet and 100-Gigabit Ethernet for high-speed uplinks. The port panel also provides a central location for the Precision Time Protocol (PTP) connections to a grandmaster clock.

This topic describes:

### Switch Overview

The ports on the QFX5110-32Q support 40-Gbps or 100-Gbps speeds natively. All ports autosense the type of transceiver and set the port to the corresponding speed. The QSFP+ ports can support channelization to four independent 10 GbE downstream ports, see "[Channelizing Interfaces](#)" on page 25. Although all network ports can be configured as either uplink or as access ports, best practice is to configure the four QSFP28 ports (**28** through **31**) as uplinks to take advantage of the 100-Gbps speeds.

The port panel also provides PTP connections to a grandmaster clock (requires Junos OS Release 18.1R1). There are also 10-MHz pulses-per-second (PPS) SubMiniature B (SMB) input and output connections to measure the timing drift to and from the grandmaster clock.

[Figure 15 on page 25](#) shows the port panel of the QFX5110-32Q.

Figure 15: QFX5110-32Q Port Panel

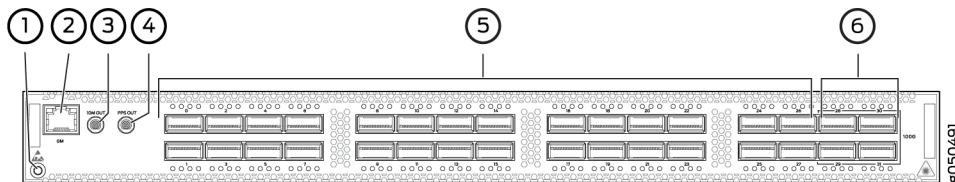

1– Electrostatic discharge (ESD) terminal	4– 1 pulse per second (PPS) output connection
2– RJ-45 connection to grandmaster clock	5– 28 QSFP+ ports
3– Output clock at 10 MHz	6– 4 QSFP28 ports

## Network Ports

The QFX5110-32Q device ports (**0** through **27**) support:

- 40-Gbps QSFP+ transceivers
- QSFP+ direct attach copper (DAC) cables
- QSFP+ active optical cables (AOC) (Junos OS Release 18.3R1 and later)
- 40-Gbps QSFP+ to SFP+ DACBO cables (40 Gbps breaks out to 10 Gbps for copper connections on supported ports)
- 40-Gbps AOCBO cables (40 Gbps breaks out to 10 Gbps for fiber connections on supported ports)

The QFX5110-32Q uplink ports (**28** through **31**) support:

- 100-Gbps QSFP28 transceivers
- 40-Gbps QSFP+ transceivers
- 100-Gbps AOC
- 40-Gbps AOC (Junos OS Release 18.3R1 or later)
- 100-Gbps QSFP28 DAC cables
- 40-Gbps QSFP+ DAC cables

## Channelizing Interfaces



**CAUTION:** Starting with Junos OS Release 18.1R1, default behaviors changed for:

- System mode—Flexi-pic mode is replaced by non-oversubscribed mode.
- Auto-sense—The ports auto-sense the transceiver and set the port speed to match.

The Packet Forwarding Engine on the switch is restarted when you issue system mode changes. As a result, you might experience packet loss on the switch.

The following system modes are available on the QFX5110-32Q:

- Default mode (from Junos OS Release 17.2R1 up to Junos OS Release 18.1R1)

All 32 QSFP+ and QSFP28 ports on the switch are configured for 40-Gigabit Ethernet only. All ports are supported as access or uplink ports, but cannot be channelized.

- Default mode (Junos OS 18.1R1 and later)

If you connect 40-Gbps optics to all 32 ports, only ports **1** through **18** are available to channelize to 4 independent 10-Gbps speed downstream ports. You can use the remaining ports as dedicated 40 Gbps ports. No ports are disabled.

Depending on the optics installed, you can channelize between 18 to 20 ports.

- If the system detects a 100-Gbps optic in any one of the QSFP28 ports (**28** to **31**), the port forms a port group and disables ports **20** to **27**. The 40 Gbps QSFP+ ports **0** to **19** can be channelized to 4 independent 10 Gbps speed downstream ports.
- If the system detects 40 Gbps optics in the QSFP28 ports (**28** to **31**), you can channelize the 40 Gbps QSFP+ ports **1** to **18** to 4 independent 10 Gbps speed downstream ports. You can use the remaining ports as dedicated 40 Gbps ports. No ports are disabled.



**CAUTION:** Ports **20** through **27** are not be available for channelization if you have populated the 100 Gbps QSFP28 ports with 100 Gbps optics.

- Flexi-pic mode (from Junos OS Release 17.2R1 up to Junos OS Release 18.1R1):
  - Ports **0** through **19** of the switch are configured for 40-Gigabit Ethernet and can be channelized to 4 independent 10-Gigabit Ethernet ports.
  - Ports **20** though **27** are disabled.
  - Ports **28** through **31** are configured as 100-Gigabit Ethernet.



**CAUTION:** Take care when changing the channelization mode from Flexi-pic to default. If you have existing ports that are channelized in Flexi-pic mode, remove the channelization from the interface before changing the system mode. Changing the Flexi-pic mode to the default mode with channelized ports causes the ports to go down, log a system log error, and remain down. You must manually remove the channelization configuration on the ports to bring the ports up in default mode. Because there can be a slight loss of data while the FPC reboots, we recommend that you only configure the changes during a maintenance window for this release.

**NOTE:** QFX5110-32Q switches that are configured for Flexi-pic mode and upgraded to Junos OS Release 18.1R1 and later come up in default mode.

- Non-oversubscribed mode (Junos OS Release 18.1R1 and later)

Ports **0** through **23** only can be channelized. The remaining ports are disabled. Use this mode to achieve 960 Gbps speeds for either 24 ports of 40 Gigabit Ethernet or 96 ports of 10 Gigabit Ethernet.

Use the request `chassis system-mode` command to change the system mode for the switch. If you attempt to channelize a non-supported port, the configuration is ignored.

## Virtual Chassis and Virtual Chassis Fabric

To connect QFX5110 switches as members in a QFX5110 Virtual Chassis, you need a pair of dedicated ports on each switch and cables that link each member in the Virtual Chassis into a ring topology. Each member in the ring has at least one direct Virtual Chassis port (VCP) connection to an upstream and downstream member. QFX5110 switches are recommended in the master, backup, or line card role. You may only mix QFX5100 members with QFX5110 members in a QFX5110 Virtual Chassis; no other QFX Series or EX Series switches are supported. See ["Connecting QFX5110 and QFX5100 Members in a QFX5110 Virtual Chassis" on page 133](#) for a diagram of cabling QFX5110 switches in a ring topology.

To connect a QFX5110 switch as a spine or leaf device in a Virtual Chassis Fabric (VCF), you need a pair of dedicated ports and cables that link each spine device and leaf device in the VCF. All spine devices have at least one direct VCP connection to each leaf device in the VCF. See ["Connecting QFX5110 in a QFX5110 Virtual Chassis Fabric" on page 134](#) for a cabling diagram.

## QFX5110 Network Port LEDs

The Link/Activity LED configuration for QFX5110-48S uses bi-colored LEDs. The link LED indicates link activity or a fault. See [Table 5 on page 28](#).

**Table 5: QFX5110-48S Access Port and Uplink LED Locations**

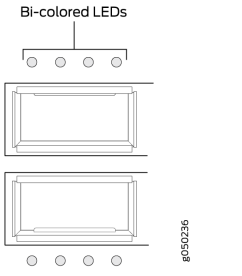
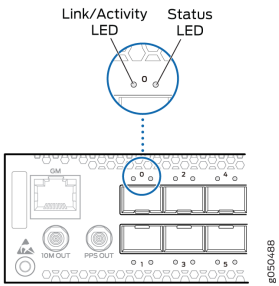
Model	Port Type	Indicators	Location
QFX5110-48S	QSFP28	Link and Activity Status  See <a href="#">Table 6 on page 28</a> .	
	SFP+	Link and Activity Status  See <a href="#">Table 7 on page 29</a> ,	

As shown in [Table 5 on page 28](#) and [Table 8 on page 30](#) there are four bi-color LEDs for each QSFP+ access port. The first LED indicates link presence and activity, while the remaining LEDs indicate status. [Table 6 on page 28](#) describes how to interpret the Link/Activity QSFP28 port LEDs, counting from the left-most position.

**Table 6: Network Port LEDs on QSFP28 Ports on a QFX5110**

Position	Color	State	Description
1-4	Unlit	Off	The port is administratively disabled, there is no power, the link is down, or there is a fault.

**Table 6: Network Port LEDs on QSFP28 Ports on a QFX5110 (Continued)**

Position	Color	State	Description
1	Green	On steadily	A link is established (either 100-Gigabit or 40-Gigabit, non-channelized) but there is no link activity. When this LED is on, the LEDs in positions 2 to 4 are off.
		Blinking	A link is established (either 100-Gigabit or 40-Gigabit, non-channelized) and there is link activity.
2-4	Green	On steadily	A 40-Gigabit link is established in channelized mode, but there is no link activity.
		Blinking	A 40-Gigabit link is established in channelized mode, and there is link activity.

[Table 7 on page 29](#) describes how to interpret the Link/Activity LEDs on SFP+ ports.

**Table 7: Network Port LEDs on SFP+ Ports on a QFX5110-48S Switch**

LED	Color	State	Description
Link/Activity	Green	Unlit	The port is administratively disabled, there is no power, the link is down, or there is a fault.
		On steadily	A link is established, but there is no link activity.
		Blinking	A link is established, and there is link activity.
Status	Green	Unlit	The link is down or there is a fault.
		On steadily	A 10-Gigabit Ethernet transceiver is installed in the port and link is established.
		Blinking	A 1-Gigabit Ethernet transceiver is installed in the port and the link is established.

Table 8: QFX5110-32Q Access Port and Uplink LED Locations

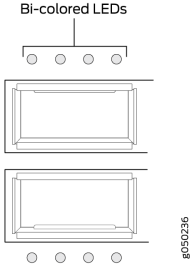
QFX5110-32Q	QSFP28 and QSFP+	Link and Activity Status	
-------------	------------------	--------------------------	---

**SEE ALSO**

[QFX5110 Management Panel | 30](#)

[Install a Transceiver | 151](#)

[Connect a Fiber-Optic Cable | 155](#)

**RELATED DOCUMENTATION**

[QFX5110 Field-Replaceable Units | 19](#)

*Channelizing Interfaces on QFX3500, QFX3600, QFX5100, QFX10002, QFX10008, QFX10016, and EX4600 Switches*

[Connecting the QFX5110 in a Virtual Chassis or Virtual Chassis Fabric | 132](#)

## QFX5110 Management Panel

**IN THIS SECTION**

- [QFX5110 Management Panel Description | 31](#)
- [QFX5110 Management Port LEDs | 32](#)
- [QFX5110 Chassis Status LEDs | 33](#)

## QFX5110 Management Panel Description

The management panel of the QFX5110 is found on the field-replaceable unit (FRU) end of the switch, as shown in [Figure 16 on page 31](#). See [Figure 17 on page 31](#) for FRUs and management panel detail.

Figure 16: QFX5110 Switch, FRU End

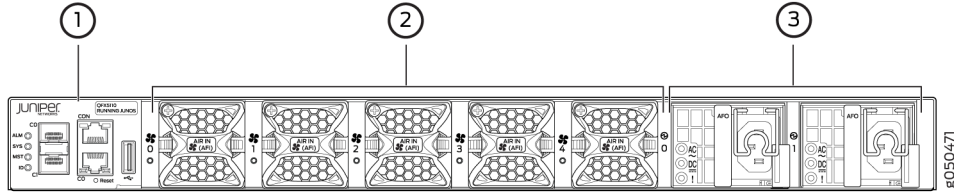

1– Management panel	3– Power supply units
2– Fan modules	

Figure 17: Management Panel Components on QFX5110

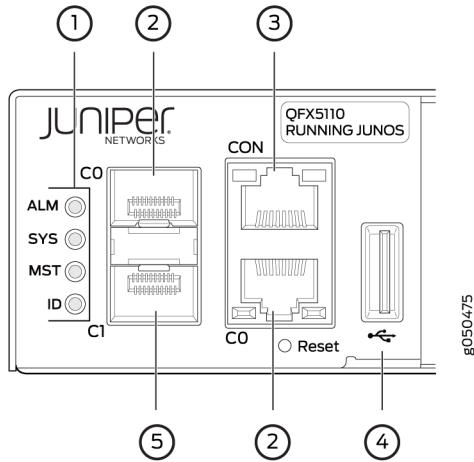

1– Status LEDs	4– USB port
2– em0-RJ-45 (1000BASE-T) management Ethernet port (C0) and an additional SFP management Ethernet port (second C0)	5– em1-SFP management Ethernet port (C1) Cage (socket for either 1-GbE copper SFP or fiber SFP)
3– RJ-45 console port (CON)	

The management panel consists of the following components:

- Status LEDs, see ["QFX5110 Chassis Status LEDs" on page 33](#).



- Switch product number
- Management ports C0 and C1, see ["QFX5110 Management Port LEDs" on page 32](#).
  - C0–Use the RJ-45 connectors for 10/100/1000BASE-T or to cable a virtual management Ethernet (VME) interface for spine members in a VCF. See ["Connect a Device to a Network for Out-of-Band Management" on page 118](#).

**NOTE:** If both C0 ports are cabled, the copper C0 has priority over the fiber C0.

- C1–Use the SFP connector for 1000BASE-X.
- USB port for image updates
- Console port (RJ-45) to support RS-232 serial ports. The LEDs above the port indicate status and link.

## QFX5110 Management Port LEDs

The management ports (labeled **C0** for 10/100/1000BASE-T and **C1** for 10/100/1000BASE-T and SFP 1000BASE-X connections) on a QFX5110 switch have two LEDs that indicate link status and link activity (see [Figure 18 on page 32](#)). The left LED indicates status; the right LED indicates link/activity.

**Figure 18: Management Port LEDs on a QFX5110**

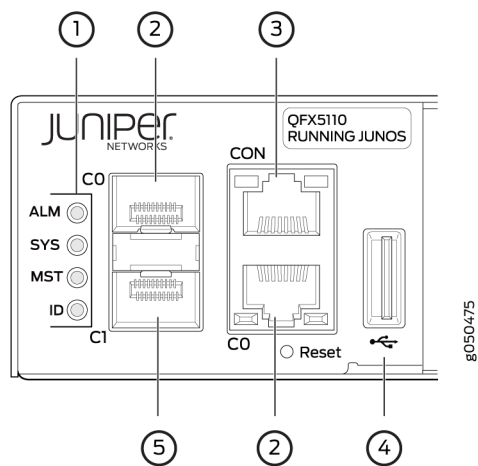

1– Status LEDs

4– USB port

2– em0–RJ-45 (10/100/1000BASE-T) management Ethernet port (C0)	5– em1–SFP management Ethernet port (C1) cage (socket for either 10/100/1000BASE-T RJ-45 SFP or 1-GbE fiber SFP)
3– RJ-45 console port (CON))	

Table 9 on page 33 describes the management port LEDs.

**Table 9: Management Port LEDs on a QFX5110**

LED	Color	State	Description
Link/Activity	Unlit	Off	No link is established, there is a fault, or the link is down.
	Green	On steadily	A link is established, but there is no link activity.
		Blinking or flickering	A link is established, and there is link activity.
Status	Unlit	Off	Either the port speed is 10 M or the link is down.
	Green	On steadily	The port speed is 1000 M.
	Amber	On steadily	The port speed is 100 M.

## QFX5110 Chassis Status LEDs

The QFX5110 switch series has four status LEDs on the FRU side of the chassis, next to the management ports (see [Figure 19 on page 34](#)).

Figure 19: Chassis Status LEDs on a QFX5110 Switch

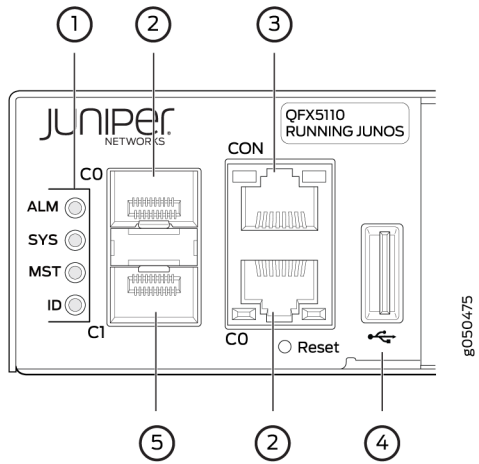

1– Status LEDs	4– USB port
2– em0–RJ-45 (10/100/1000 BASE-T) management Ethernet port (C0)	5– em1–SFP management Ethernet port (C1) cage (socket for either 10/100/1000 BASE-T RJ-45 SFP or 1-GbE fiber SFP)
3– RJ-45 console port (CON)	

Table 10 on page 34 describes the chassis status LEDs on a QFX5110, their colors and states, and the status they indicate. You can view the colors of the three LEDs remotely through the CLI by issuing the operational mode command `show chassis lcd`.

Table 10: Chassis Status LEDs on a QFX5110 Switch

Name	Color	State	Description
ALM–Alarm or beacon	Unlit	Off	The switch is halted or there is no alarm.

Table 10: Chassis Status LEDs on a QFX5110 Switch (*Continued*)

Name	Color	State	Description
	Red	On steadily	A major hardware fault has occurred, such as a temperature alarm or power failure, and the switch has halted. Power off the QFX5110 by setting the AC power source outlet to the off (O) position, or unplugging the AC power cords. Correct any voltage or site temperature issues, and allow the switch to cool down. Power on the QFX5110 and monitor the power supply and fan LEDs to help determine where the error is occurring.
	Amber	On steadily	A minor, non-critical alarm has occurred, such as a software error. Power off the QFX5110 by setting the AC power source outlet to the off (O) position, or unplugging the AC power cords. Power on the QFX5110 and monitor the status LEDs to ensure that Junos OS boots properly.
SYS-System	Unlit	Off	The switch is powered off or halted.
	Green	On steadily	Junos OS for QFX Series is loaded on the switch.

Table 10: Chassis Status LEDs on a QFX5110 Switch (Continued)

Name	Color	State	Description
	Green	Blinking	<p>The switch is participating as:</p> <ul style="list-style-type: none"> <li>• A member in a QFX Virtual Chassis</li> <li>• A leaf device in a Virtual Chassis Fabric (VCF)</li> <li>• A spine device in a VCF</li> <li>• A Routing Engine Primary in a VCF</li> <li>• A Routing Engine Backup in a VCF</li> </ul>
MST-Primary in a QFX Virtual Chassis or Routing Engine Primary in a VCF	Unlit	Off	The switch is a line card member in a QFX Virtual Chassis.
	Green	On steadily	<p>The switch is one of the following:</p> <ul style="list-style-type: none"> <li>• A standalone switch</li> <li>• In the primary role in a QFX Virtual Chassis</li> <li>• Is the routing engine primary in a VCF</li> </ul>
	Green	Blinking	The switch is the backup primary in a QFX Virtual Chassis or the backup routing engine in a VCF.
ID-Identification	Unlit	Off	The beacon feature is not enabled on the switch. This feature is enabled using the request chassis beacon command.

**Table 10: Chassis Status LEDs on a QFX5110 Switch (Continued)**

Name	Color	State	Description
	Blue	Blinking	The beacon feature is enabled on the switch. This feature is enabled using the <code>request chassis beacon</code> command.

#### SEE ALSO

*show chassis alarms*

*request chassis beacon*

#### RELATED DOCUMENTATION

[QFX5110 Field-Replaceable Units | 19](#)

[USB Port Specifications for the QFX Series | 98](#)

## QFX5110 Cooling System

#### IN THIS SECTION

- [QFX5110 Cooling System and Airflow Description | 38](#)
- [QFX5110 Fan Module LED | 43](#)

## QFX5110 Cooling System and Airflow Description

### IN THIS SECTION

- [Fan Modules | 38](#)
- [Do Not Install Components with Different Airflow or Wattage in the Switch | 43](#)

The cooling system in an QFX5110 device consists of five fan modules and a single fan in each power supply. The switch can be set up to work in one of two airflow directions:

- Airflow In–Air comes into the switch through the vents in the field-replaceable units (FRUs)
- Airflow Out–Air comes into the switch through the vents in the port panel.

All QFX5110 switches, except the QFX5110-32Q-CHAS, are shipped with five fan modules and two power supplies. Order fans for the QFX5110-32Q-CHAS separately.



**CAUTION:** Airflow In and Airflow Out fans and power supplies cannot be mixed in the same chassis.

This topic describes:

### Fan Modules

The fan modules in QFX5110 devices are hot-insertable and hot-removable FRUs. These fan modules are designed for one of the two available airflow directions (Airflow In or Airflow Out). The fan modules are also color-coded for the airflow direction. The fan modules are installed in the fan module slots between the management panel and the power supplies.

The QFX5110 fan modules have five fan modules numbered 0 through 4 counting from left to right. Each fan module slot has a fan icon next to it.

[Figure 20 on page 39](#) shows the fan module.

Figure 20: QFX5110 Fan Module

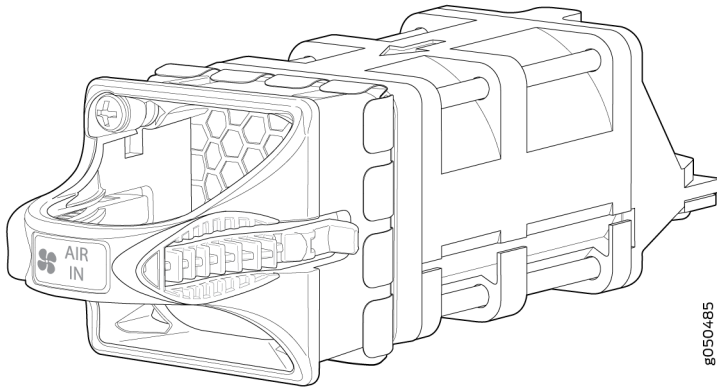

You remove and replace a fan module from the FRU end of the chassis. The switch continues to operate for a limited period of time (30 seconds) during the replacement of the fan module without thermal shutdown.

**NOTE:** All fan modules must be installed for optimal operation of the switch.

The fan modules are available in two product SKUs that have different airflow directions, airflow in and airflow out. Airflow in is indicated on the module by the azure blue color and a label marked **AIR IN**. Airflow in this version of the fan module bring air into the fans and power supplies and exhaust air through the ports. Likewise, airflow out is indicated by a gold color and a label marked **AIR OUT**. Airflow out versions of the fan module brings air into the switch through the vents around the ports and exhaust air through the fans and power supplies. [Table 11 on page 39](#) lists the available fan module product SKUs and the direction of airflow in them.

Table 11: Fan Modules in the QFX5110

Fan Module	Airflow Diagram	Label on the Fan Module	Color of Fan Module	Direction of Airflow in the Fan Module	Power Supplies
QFX5110-48S-FANAFI	<a href="#">Figure 21 on page 41</a>	<b>AIR IN</b>	Juniper Azure Blue	FRU-to-port, that is, air comes in from the end of the switch with the fans; air exhausts from the switch end with ports (also known as back-to-front airflow).	You must install only power supplies that have <b>AIR IN</b> labels in switches in which the fan modules have <b>AIR IN</b> labels.



Table 11: Fan Modules in the QFX5110 (Continued)

Fan Module	Airflow Diagram	Label on the Fan Module	Color of Fan Module	Direction of Airflow in the Fan Module	Power Supplies
QFX5110-48S-FANAFO	<a href="#">Figure 22 on page 41</a>	<b>AIR OUT</b>	Juniper Gold	Port-to-FRU, that is, air comes in through vents on the end with ports; air exhausts out the end with the fans (also known as front-to-back airflow).	You must install only power supplies that have <b>AIR OUT</b> labels in switches in which the fan modules have <b>AIR OUT</b> labels.

Table 11: Fan Modules in the QFX5110 (Continued)

QFX5110-32Q-FANAFI	<a href="#">Figure 23 on page 42</a>	<b>AIR IN</b>	Juniper Azure Blue	FRU-to-port, that is, air comes in from the end of the switch with the fans; air exhausts from the switch end with ports (also known as back-to-front airflow).	You must install only power supplies that have <b>AIR IN</b> labels in switches in which the fan modules have <b>AIR IN</b> labels.
QFX5110-32Q-FANAFO	<a href="#">Figure 24 on page 42</a>	<b>AIR OUT</b>	Juniper Gold	Port-to-FRU, that is, air comes in through vents on the end with ports; air exhausts out the end with the fans (also known as front-to-back airflow).	You must install only power supplies that have <b>AIR OUT</b> labels in switches in which the fan modules have <b>AIR OUT</b> labels.

In data center deployments, position the switch in such a manner that the **AIR IN** labels on switch components are next to the cold aisle, and **AIR OUT** labels on switch components are next to the hot aisle. See [Figure 21 on page 41](#) through [Figure 24 on page 42](#).

Figure 21: Air In Airflow Through the QFX5110-48S

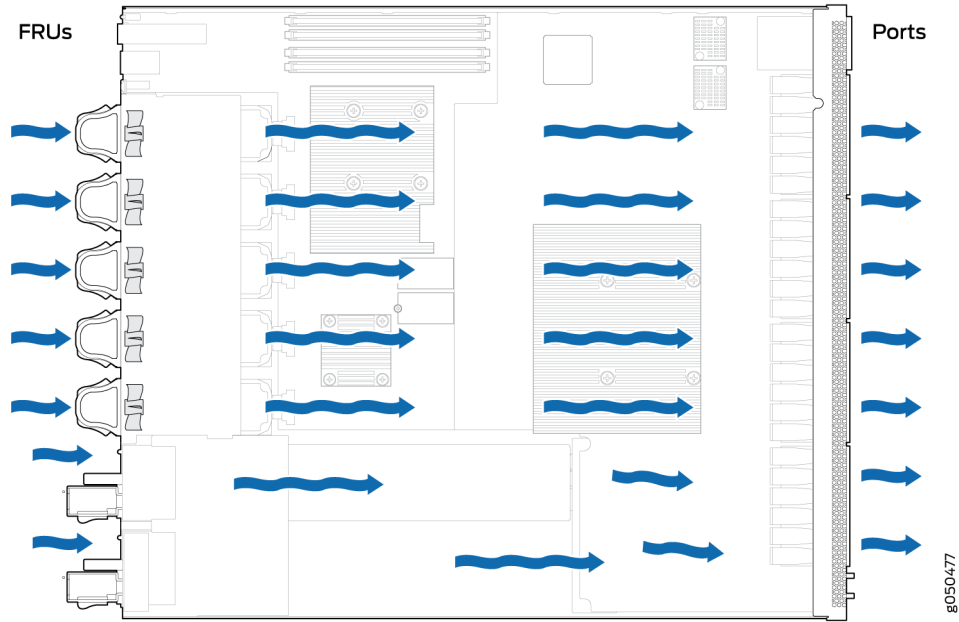

Figure 22: Air Out Airflow Through the QFX5110-48S

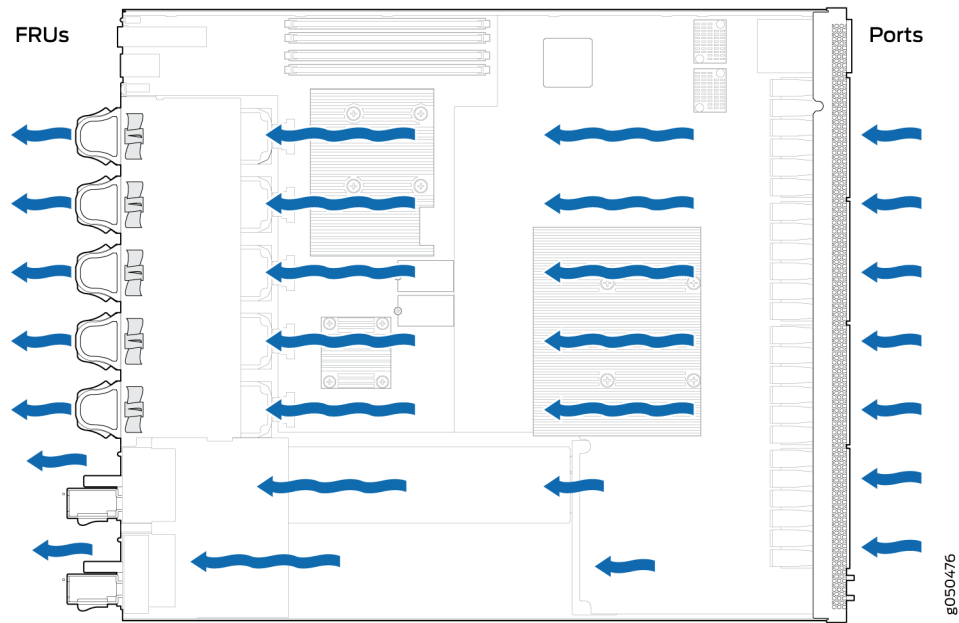

Figure 23: Air In Airflow Through the QFX5110-32Q

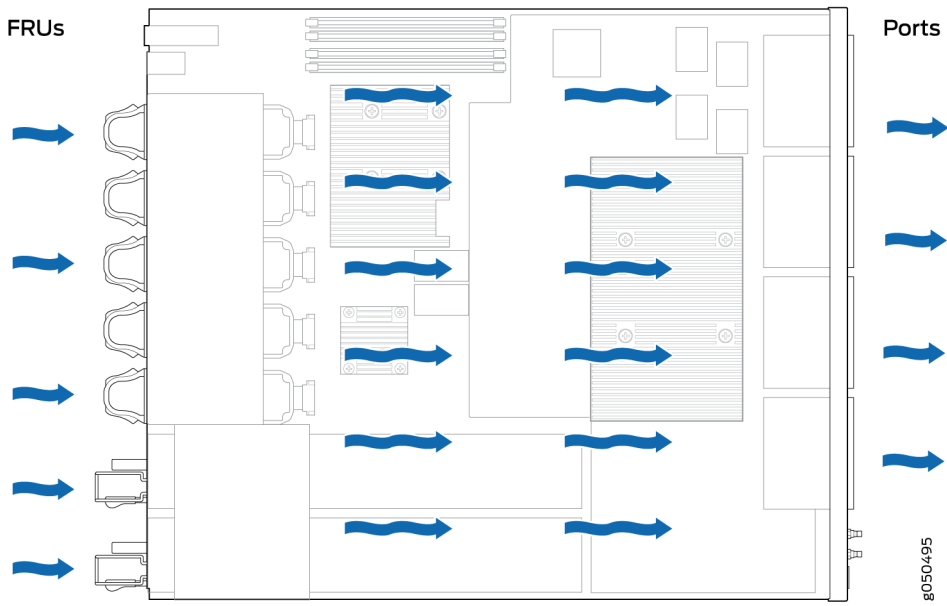
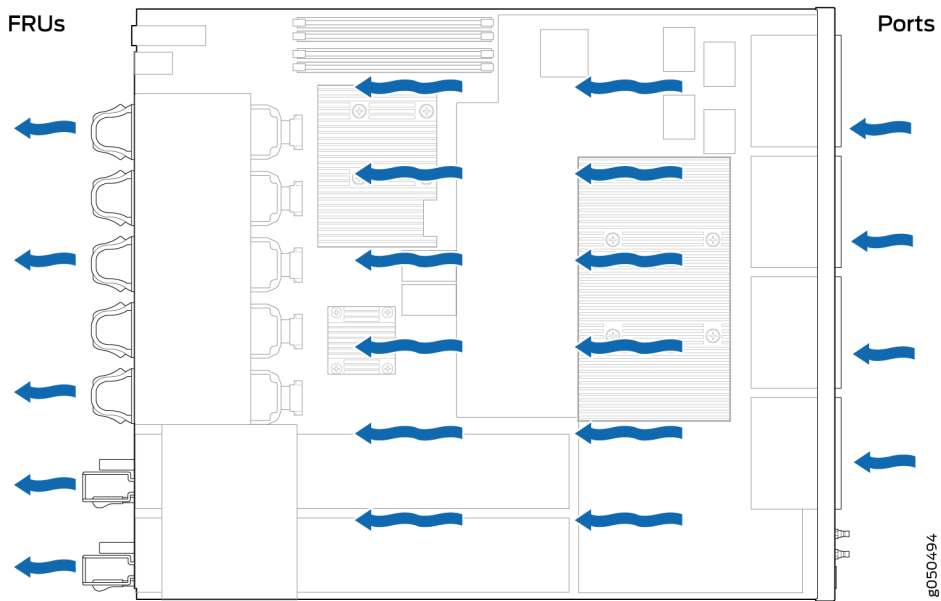

Figure 24: Air Out Airflow Through the QFX5110-32Q



## Do Not Install Components with Different Airflow or Wattage in the Switch

Do not mix power supplies with different airflow. If the power supplies are color-coded, ensure they are either all azure blue for airflow in models or all gold for airflow out models. If the power supplies are not color-coded but have a label, ensure that the chassis is either using all airflow in (**AFI**) or all airflow out (**AFO**). Likewise, ensure that all fan modules have the same airflow and match the airflow of the power supplies. Fan modules are also either color-coded azure blue for airflow in or gold for airflow out. If the fan module has a label instead of being color-coded, ensure that labels (**AIR IN** and **AIR OUT**) are not mixed. If the fan modules have **AIR IN** labels, the power supplies must also have **AIR IN** labels; if the fan modules have **AIR OUT** labels, the power supplies must also have **AIR OUT** labels.

Mixing components with different airflows in the same chassis hampers the performance of the cooling system of the switch and leads to overheating of the chassis.



**CAUTION:** The system raises an alarm if a fan module fails or if the ambient temperature inside the chassis rises above the acceptable range. If the temperature inside the chassis rises above the threshold temperature, the system shuts down automatically.

Do not mix fan modules with different wattage. Only use the replacement fan modules that are designed for use with your product number. See [Table 11 on page 39](#) for the correct part number for your QFX5110.



**CAUTION:** Do not mix AC and DC power supplies in the same chassis.

However, if you need to convert a QFX5110 to have a different airflow, you can change the airflow pattern. To convert an **AIR IN** product SKU to an **AIR OUT** product SKU or an **AIR OUT** product SKU to a **AIR IN** product SKU, you must replace all of the fans and power supplies at one time to use the new direction. The system raises an alarm when the system is converted, which is normal.

## QFX5110 Fan Module LED

[Figure 25 on page 44](#) shows the location of the LED next to the fan module.

Figure 25: Fan Module LED in a QFX5110 Switch

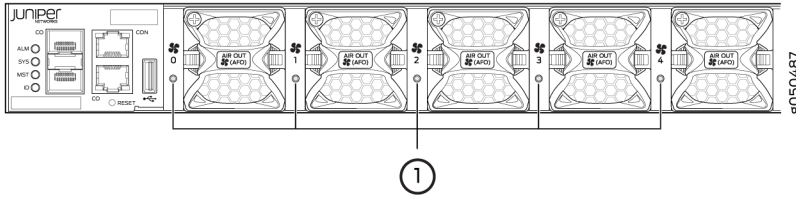

1– Fan LED

Table 12 on page 44 describes the function of the fan tray LED.

Table 12: Fan Tray LED in a QFX5110 Switch

Name	Color	State	Description
Fan	Green	On steadily	The fan module is operating normally. The system has verified that the module is engaged, that the airflow is in the correct direction, and that the fan is operating correctly.
	Amber	Blinking	An error has been detected in the fan module. Replace the fan module as soon as possible. Either the fan has failed or it is seated incorrectly. To maintain proper airflow through the chassis, leave the fan module installed in the chassis until you are ready to replace it.

Under normal operating conditions, the fan modules operate at a moderate speed. Temperature sensors in the chassis monitor the temperature within the chassis.

The system raises an alarm if a fan module fails or if the ambient temperature inside the chassis rises above the acceptable range. If the temperature inside the chassis rises above the threshold temperature, the system shuts down automatically.

**RELATED DOCUMENTATION**

[QFX5110 System Overview | 12](#)

[Prevention of Electrostatic Discharge Damage | 202](#)

[Maintaining QFX5110 Fan Modules | 141](#)

# QFX5110 Power System

## IN THIS SECTION

- [QFX5110 AC Power Supply Description | 45](#)
- [QFX5110 AC Power Specifications | 47](#)
- [QFX5110 AC Power Cord Specifications | 48](#)
- [QFX5110 AC Power Supply LEDs | 50](#)
- [QFX5110 DC Power Supply Description | 51](#)
- [QFX5110 DC Power Specifications | 54](#)
- [QFX5110 DC Power Supply LEDs | 55](#)

## QFX5110 AC Power Supply Description

Except for the QFX5110-32Q-CHAS, the QFX5110 switches are shipped from the factory with two 650 W power supplies pre-installed. See [Figure 26 on page 46](#) for an example of a QFX5110 AC power supply. The power supplies are fully redundant, load-sharing, and hot-removable and hot-insertable FRUs when the second power supply is installed and running. You can install replacement power supplies in the two slots next to the fan modules without powering off the switch or disrupting the switching function.

The AC power supply in QFX5110 switches is available in different airflow configurations. Be sure to use the correct power supply for your chassis product SKU (see [Table 13 on page 47](#)).



**CAUTION:** Do not mix power supplies with different airflow. The system raises an alarm when a power supply having a different airflow or wattage is inserted into the chassis.

Figure 26: AC Power Supply in QFX5110 Switches

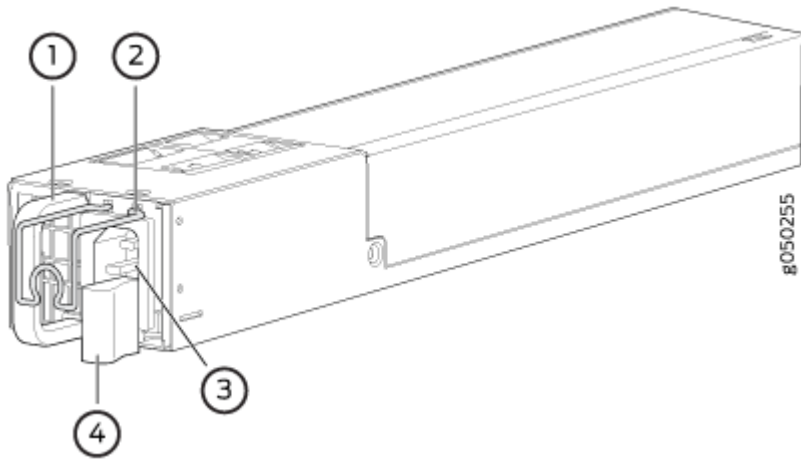

1– Handle

3– AC appliance inlet

2– Power cord retainer

4– Security latch

The power supply provides FRU-to-port or port-to-FRU airflow depending on the product SKU you purchase. On legacy switches, or switches with an LCD, this airflow is called back-to-front and front-to-back. The power supplies either have labels on the handles that indicate the direction of airflow or they have color-coded handles with a fan icon. See [Figure 27 on page 46](#) for an example of the power supply. Either a power supply has the label **AFI** or a blue handle, which denotes FRU-to-port airflow. A power supply with the label **AFO** or a gold-colored handle denotes port-to-FRU airflow.

Figure 27: Power Supply Handle Detail

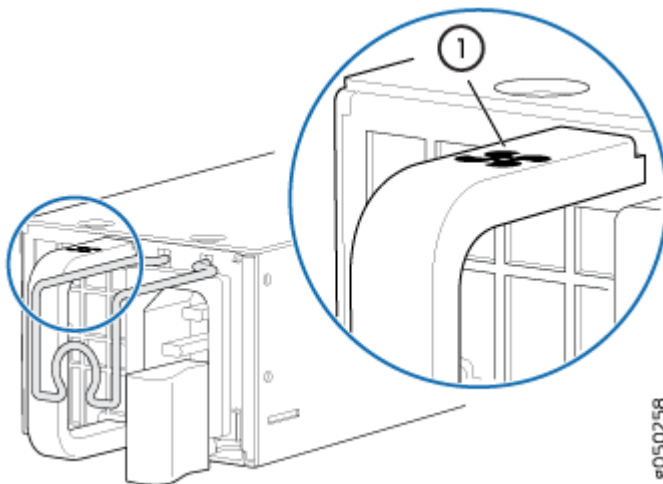

1– Fan icon on handle



**CAUTION:** Verify that the airflow direction on the power supply handle matches the direction of airflow in the chassis. Ensure that each power supply you install in the chassis has the same airflow direction. If you install power supplies with two different airflow directions, Junos OS raises an alarm. If you need to convert the airflow pattern on a chassis, you must change out all the fans and power supplies at one time to use the new direction.

Table 13 on page 47 shows the different power supplies and their direction of airflow.

**Table 13: Airflow Direction in QFX5110 AC Power Supplies**

Product Number	Direction of Airflow	Color of Power Supply Handle
JPSU-650W-AC-AFI	FRU-to-port	Juniper Azure Blue
JPSU-650W-AC-AFO	Port-to-FRU	Juniper Gold

To avoid electrical injury, carefully follow instructions in "[Connecting AC Power to a QFX5110](#)" on page 124.

## QFX5110 AC Power Specifications

Table 14 on page 47 describes the AC power specifications for QFX5110 switches. The typical and maximum power consumption values are calculated using small form-factor plus (SFP+) direct attach copper (DAC) cables on all network ports and all 100GBASE-SR4 transceivers in the uplink ports. Traffic is run at 25° C ambient.

**Table 14: AC Power Specifications for QFX5110 Models**

Item	QFX5110-48S Specification	QFX5110-32Q Specification
AC input voltage	Operating range: 90 VAC to 264 VAC	Operating range: 90 VAC to 264 VAC
AC input line frequency	50–60 Hz	50–60 Hz



**Table 14: AC Power Specifications for QFX5110 Models (Continued)**

Item	QFX5110-48S Specification	QFX5110-32Q Specification
AC input current rating	3.6 A at 90 VAC	3.6 A at 90 VAC
Idle power consumption	150 W	250 W
Typical power consumption	190 W (input current of 0.973 A at 220 VAC)	148 W
Maximum power consumption	226 W	200 W



## QFX5110 AC Power Cord Specifications

Detachable AC power cords are shipped with the chassis, if you include them as part of your order. The coupler is type C13 as described by International Electrotechnical Commission (IEC) standard 60320. The plug end of the power cord fits into the power source outlet that is standard for your geographical location.

**NOTE:** In North America, AC power cords must not exceed 14.75 feet (approximately 4.5 meters) in length, to comply with National Electrical Code (NEC) Sections 400-8 (NFPA 75, 5-2.2) and 210-52, and Canadian Electrical Code (CEC) Section 4-010(3). The cords that can be ordered for the QFX Series switches are in compliance.

[Table 15 on page 49](#) lists AC power cord specifications provided for each country or region.

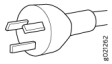
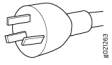
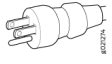
Table 15: AC Power Cord Specifications

Country/Region	Electrical Specifications	Plug Standards	Juniper Model Number	Spare Juniper Model Number	Graphic
Australia	250 VAC, 10 A, 50 Hz	IEC 60884-1	CG_CBL-C13-06-AU	CBL-EX-PWR-C13-AU	
China	250 VAC, 10 A, 50 Hz	GB 2099.1-2008	CG_CBL-C13-06-CH	CBL-EX-PWR-C13-CH	
Europe (except Italy, Switzerland, and United Kingdom)	250 VAC, 10 A, 50 Hz	IEC 60884-1	CG_CBL-C13-06-EU	CBL-EX-PWR-C13-EU	
Italy	250 VAC, 10 A, 50 Hz	CEI.23-16/VII	CG_CBL-C13-06-IT	CBL-EX-PWR-C13-IT	
Japan	125 VAC, 12 A, 50 Hz or 60 Hz	JIS C8303	CG_CBL-C13-06-JP	CBL-EX-PWR-C13-JP	
North America	125 VAC, 13 A, 60 Hz	NEMA 5-ISP	CG_CBL-C13-06-US	CBL-EX-PWR-C13-US	
South Korea	250 VAC, 10 A, 60 Hz	KSC 8305	CG_CBL-C13-06-KR	CBL-EX-PWR-C13-KR	
Switzerland	250 VAC, 10 A, 50 Hz	SEV 1011-2009	CG_CBL-C13-06-SZ	CBL-EX-PWR-C13-SZ	
United Kingdom	250 VAC, 10 A, 50 Hz	BS 1363	CG_CBL-C13-06--UK	CBL-EX-PWR-C13-UK	

**SEE ALSO**

[QFX5110 AC Power Supply Description | 45](#)

[General Safety Guidelines and Warnings | 178](#)

[General Electrical Safety Guidelines and Warnings | 200](#)

[Prevention of Electrostatic Discharge Damage | 202](#)

*AC Power Supply for a QFX5100 Device*

*QFX10002 AC Power Specifications*

*QFX5200 AC Power Specifications*

[QFX5110 AC Power Supply Description | 45](#)

**QFX5110 AC Power Supply LEDs**

[Figure 28 on page 50](#) shows the location of the LEDs on the power supply.

**Figure 28: AC Power Supply LEDs on a QFX5110 Switch**

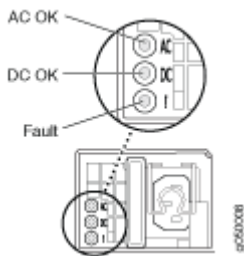

[Table 16 on page 50](#) describes the LEDs on the AC power supplies.

**Table 16: AC Power Supply LEDs on a QFX5110 Switch**

LED	Color	State	Description
AC OK	Unlit	Off	The power supply is disconnected from power, or power is not coming into the power supply.
	Green	On steadily	Power is coming into the power supply.

**Table 16: AC Power Supply LEDs on a QFX5110 Switch (Continued)**

LED	Color	State	Description
DC OK	Unlit	Off	The power supply is disconnected from power, or the power supply is not sending out power correctly.
	Green	On steadily	The power supply is sending out power correctly.
Fault	Amber	On steadily	An error has been detected in the power supply. Replace the power supply as soon as possible. To maintain proper airflow through the chassis, leave the power supply installed in the chassis until you are ready to replace it.

**NOTE:** If the **AC OK** LED and the **DC OK** LED are unlit, either the AC power cord is not installed properly or the power supply fuse has failed. If the **AC OK** LED is lit and the **DC OK** LED is unlit, the AC power supply is installed properly, but the power supply has an internal failure.

## QFX5110 DC Power Supply Description

Except for the QFX5110-32Q-CHAS, the QFX5110 switches are shipped from the factory with two power supplies (see [Figure 29 on page 52](#)). Each power supply is a hot-removable and hot-insertable field-replaceable unit (FRU) when the second power supply is installed and running. You can install replacement power supplies in the two slots next to the fan modules without powering off the switch or disrupting the switching function.

The DC power supply in QFX5110 is 650 W with dual feeds for power resiliency.

Figure 29: DC Power Supply for the QFX5110

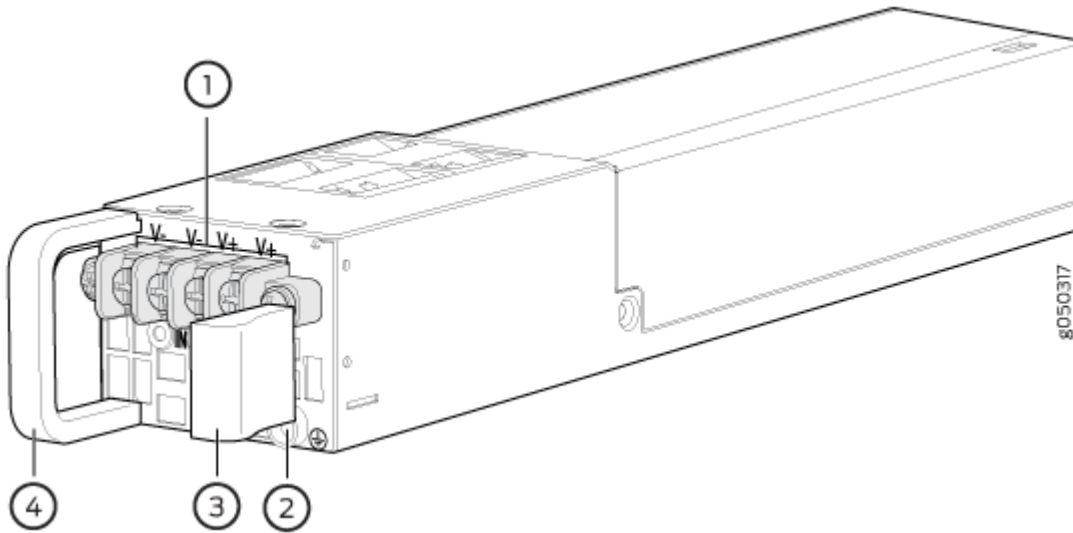

1- Terminal block

3- Security latch

2- Protective earthing terminal

4- Handle

**NOTE:** The DC power supply in the switch has four terminals labeled V-, V-, V+, and V+ (see [Figure 30 on page 53](#)) for connecting DC power source cables labeled positive (+) and negative (-).

Figure 30: DC Power Supply Faceplate on a QFX5110

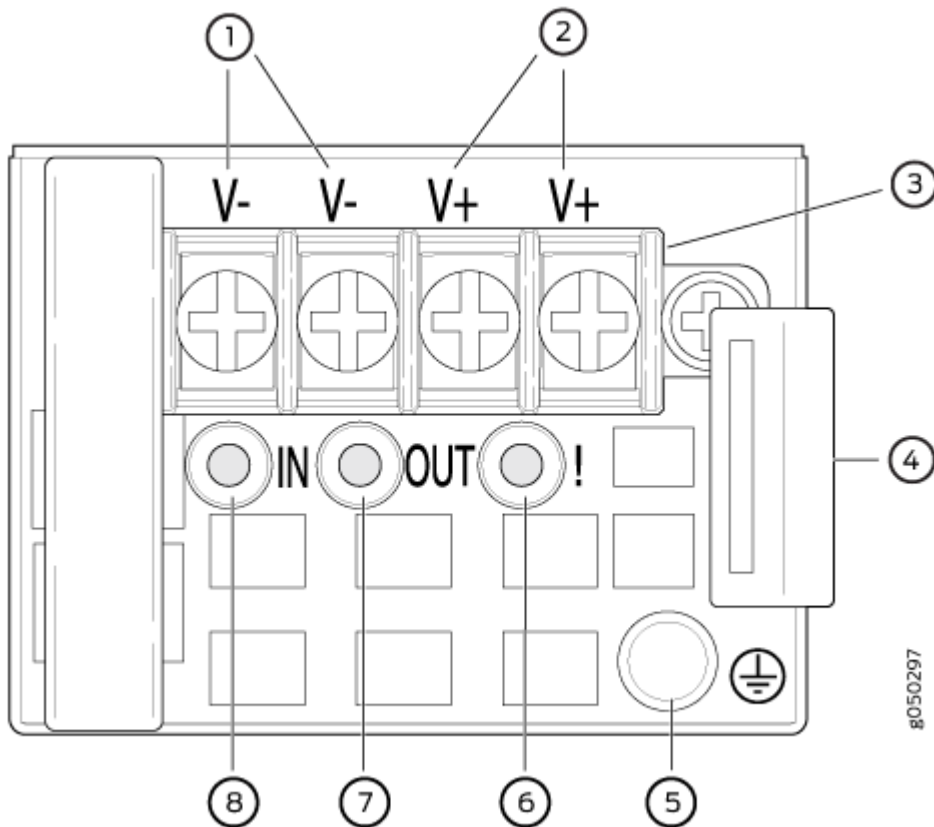

1– Shunt negative input terminals (-48V)	5– Protective earthing terminal
2– Shunt positive input terminals (+RTN)	6– Fault LED
3– Terminal block	7– Output LED
4– Security latch	8– Input LED



**CAUTION:** Verify that the airflow direction on the power supply handle matches the direction of airflow in the chassis. Ensure that each power supply you install in the chassis has the same airflow direction. If you install power supplies with two different airflow directions, Junos OS raises an alarm. If you need to convert the airflow pattern on a chassis, you must change out all the fans and power supplies at one time to use the new direction.

Table 17 on page 54 shows the different power supplies and their direction of airflow.

**Table 17: Airflow Direction in QFX5110 DC Power Supplies**

Product Number	Direction of Airflow	Color of Power Supply Handle
JPSU-650W-DC-AFI	FRU-to-port	Juniper Azure Blue
JPSU-650W-DC-AFO	Port-to-FRU	Juniper Gold

To avoid electrical injury, carefully follow the instructions in [Maintaining the QFX5220 Power System](#).

## QFX5110 DC Power Specifications

[Table 18 on page 54](#) describes the QFX5110 DC power specifications. The typical and maximum power consumption values are calculated using dummy transceivers on all ports. Traffic is run at 25° C ambient.

**Table 18: DC Power Specifications for QFX5110**

Item	Specifications
DC input voltage	<ul style="list-style-type: none"> <li>Rated operating voltage: -39 VDC to -60 VDC</li> <li>Operating voltage range: -40 VDC through -72 VDC</li> </ul>
DC input current rating	-8.2 A at 39 VDC
Idle power consumption	
<ul style="list-style-type: none"> <li>QFX5110-48S</li> <li>QFX5110-32Q</li> </ul>	<ul style="list-style-type: none"> <li>150 W</li> <li>250 W</li> </ul>
Typical power consumption	

**Table 18: DC Power Specifications for QFX5110 (Continued)**

Item	Specifications
<ul style="list-style-type: none"> <li>• QFX5110-48S</li> <li>• QFX5110-32Q</li> </ul>	<ul style="list-style-type: none"> <li>• 190 W</li> <li>• 280 W</li> </ul>
Maximum power consumption	
<ul style="list-style-type: none"> <li>• QFX5110-48S</li> <li>• QFX5110-32Q</li> </ul>	<ul style="list-style-type: none"> <li>• 248 W</li> <li>• 335 W</li> </ul>

## QFX5110 DC Power Supply LEDs

Figure 31 on page 55 shows the location of the LEDs on the DC power supply.

**Figure 31: DC Power Supply Faceplate on a QFX5110 Switch**

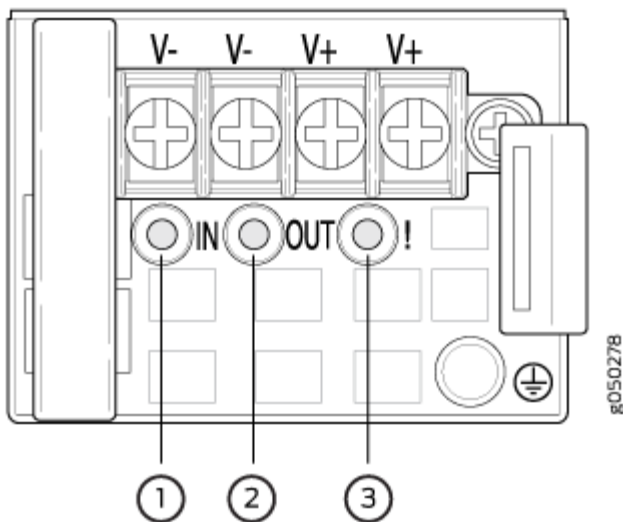

1- Input LED

2- Output LED

3- Fault LED





**CAUTION:** The V+ terminals are shunted internally together, as are the V- terminals. The same polarity terminal can be wired together from the same source to provide an additional current path in a higher power chassis. Do not connect the terminals to different sources.

Table 19 on page 56 describes the LEDs on the DC power supplies.

**Table 19: DC Power Supply LEDs on a QFX5110 Switch**

Name	Color	State	Description
Input	Unlit	Off	The power supply is disconnected from power, or power is not coming into the power supply.
	Green	On steadily	Power is coming into the power supply.
Output	Unlit	Off	The power supply is disconnected from power, or the power supply is not sending out power correctly.
	Green	On steadily	The power supply is sending out power correctly.
Fault	Amber	On steadily	An error has been detected in the power supply. Replace the power supply as soon as possible. To maintain proper airflow through the chassis, leave the power supply installed in the chassis until you are ready to replace it.

# 3

CHAPTER

## Site Planning, Preparation, and Specifications

---

QFX5110 Site Preparation Checklist | 58

QFX5110 Site Guidelines and Requirements | 60

QFX5110 Deployment in a Virtual Chassis or Virtual Chassis Fabric | 68

QFX5110 Network Cable and Transceiver Planning | 80

QFX5110 Management Cable Specifications and Pinouts | 88

---

# QFX5110 Site Preparation Checklist

The checklist in [Table 20 on page 58](#) summarizes the tasks you need to perform when preparing a site for a QFX5110 installation.

**Table 20: Site Preparation Checklist**

Item or Task	For More Information	Performed By	Date
<b>Architecture</b>			
Determine whether the QFX5110 device will operate: <ul style="list-style-type: none"> <li>standalone</li> <li>as a member in a Virtual Chassis</li> <li>as a spine or leaf in a Virtual Chassis Fabric (VCF)</li> </ul>	<ul style="list-style-type: none"> <li><a href="#">"Planning a Virtual Chassis Deployment using QFX Devices" on page 68</a></li> <li><a href="#">"Plan a Virtual Chassis Fabric Deployment" on page 76</a></li> </ul>		
<b>Environment</b>			
Verify that environmental factors such as temperature and humidity do not exceed switch tolerances.	<a href="#">"QFX5110 Environmental Requirements and Specifications" on page 60</a>		
<b>Power</b>			
Measure the distance between external power sources and switch installation site.			
Calculate the power consumption and requirements.	<a href="#">"QFX5110 AC Power Specifications" on page 47</a> and <a href="#">"QFX5110 DC Power Specifications" on page 54</a>		
<b>Rack</b>			

Table 20: Site Preparation Checklist (Continued)

Item or Task	For More Information	Performed By	Date
Verify that your rack meets the minimum requirements for the installation of the switch.	<a href="#">"QFX5110 Rack Requirements" on page 66</a>		
Plan rack location, including required space clearances.	<a href="#">"QFX5110 Clearance Requirements for Airflow and Hardware Maintenance" on page 64</a>		
Secure the rack or cabinet to the floor and building structure.			
<b>Cables</b>			
<p>Acquire cables and connectors:</p> <ul style="list-style-type: none"> <li>• Determine the number of cables needed based on your planned configuration.</li> <li>• Review the maximum distance allowed for each cable. Choose the length of cable based on the distance between the hardware components being connected.</li> </ul>	<a href="#">"QFX5110 Network Cable and Transceiver Planning" on page 80</a>		
Plan the cable routing and management.			

**RELATED DOCUMENTATION**

---

*General Safety Guidelines and Warnings*

*General Site Guidelines*

# QFX5110 Site Guidelines and Requirements

## IN THIS SECTION

- [QFX5110 Environmental Requirements and Specifications | 60](#)
- [General Site Guidelines | 61](#)
- [Site Electrical Wiring Guidelines | 62](#)
- [QFX5110 Chassis Grounding Cable and Lug Specifications | 63](#)
- [QFX5110 Clearance Requirements for Airflow and Hardware Maintenance | 64](#)
- [QFX5110 Chassis Physical Specifications | 65](#)
- [QFX5110 Rack Requirements | 66](#)

## QFX5110 Environmental Requirements and Specifications

The switch must be installed in a rack or cabinet. It must be housed in a dry, clean, well-ventilated, and temperature-controlled environment.

Follow these environmental guidelines:

- The site must be as dust-free as possible, because dust can clog air intake vents and filters, reducing the efficiency of the switch cooling system.
- Maintain ambient airflow for normal switch operation. If the airflow is blocked or restricted, or if the intake air is too warm, the switch might overheat, leading to the switch temperature monitor shutting down the device to protect the hardware components.

[Table 21 on page 60](#) provides the required environmental conditions for normal switch operation for all QFX5110 models.

**Table 21: QFX5110 Environmental Tolerances**

Description	Tolerance
Altitude	No performance degradation to 6562 feet (2000 meters)

Table 21: QFX5110 Environmental Tolerances (Continued)

Description	Tolerance
Relative humidity	<p>Normal operation ensured in relative humidity range of 5% through 90%, noncondensing</p> <ul style="list-style-type: none"> <li>Short-term operation ensured in relative humidity range of 5% through 93%, noncondensing</li> </ul> <p><b>NOTE:</b> As defined in NEBS GR-63-CORE, Issue 3, short-term events can be up to 96 hours in duration but not more than 15 days per year.</p>
Temperature	<ul style="list-style-type: none"> <li>Normal operation ensured in temperature range of 32° F through 104° F (0° C through 40° C)</li> <li>Nonoperating storage temperature in shipping container: -40° F through 158° F (-40° C through 70° C)</li> </ul>
Seismic	Designed to comply with Zone 4 earthquake requirements per NEBS GR-63-CORE, Issue 3.

**NOTE:** Install QFX Series devices only in restricted areas, such as dedicated equipment rooms and equipment closets, in accordance with Articles 110-16, 110-17, and 110-18 of the National Electrical Code, ANSI/NFPA 70.

## SEE ALSO

[QFX5110 Clearance Requirements for Airflow and Hardware Maintenance | 64](#)

[Standalone Installation Overview | 100](#)

## General Site Guidelines

Efficient device operation requires proper site planning and maintenance. It also requires proper layout of the equipment, rack or cabinet, and wiring closet.

To plan and create an acceptable operating environment for your device and prevent environmentally caused equipment failures:

- Keep the area around the chassis free from dust and conductive material, such as metal flakes.
- Follow the prescribed airflow guidelines to ensure that the cooling system functions properly. Ensure that exhaust from other equipment does not blow into the intake vents of the device.
- Follow the prescribed electrostatic discharge (ESD) prevention procedures to prevent damaging the equipment. Static discharge can cause components to fail completely or intermittently over time.
- Install the device in a secure area, so that only authorized personnel can access the device.

## Site Electrical Wiring Guidelines

Table 22 on page 62 describes the factors you must consider while planning the electrical wiring at your site.



**WARNING:** You must provide a properly grounded and shielded environment and use electrical surge-suppression devices.

**Avertissement** Vous devez établir un environnement protégé et convenablement mis à la terre et utiliser des dispositifs de parasurtension.

**Table 22: Site Electrical Wiring Guidelines**

Site Wiring Factor	Guidelines
Signaling limitations	<p>If your site experiences any of the following problems, consult experts in electrical surge suppression and shielding:</p> <ul style="list-style-type: none"> <li>• Improperly installed wires cause radio frequency interference (RFI).</li> <li>• Damage from lightning strikes occurs when wires exceed recommended distances or pass between buildings.</li> <li>• Electromagnetic pulses (EMPs) caused by lightning damage unshielded conductors and electronic devices.</li> </ul>

Table 22: Site Electrical Wiring Guidelines (Continued)

Site Wiring Factor	Guidelines
Radio frequency interference	<p>To reduce or eliminate RFI from your site wiring, do the following:</p> <ul style="list-style-type: none"> <li>• Use a twisted-pair cable with a good distribution of grounding conductors.</li> <li>• If you must exceed the recommended distances, use a high-quality twisted-pair cable with one ground conductor for each data signal, when applicable.</li> </ul>
Electromagnetic compatibility	<p>If your site is susceptible to problems with electromagnetic compatibility (EMC), particularly from lightning or radio transmitters, seek expert advice.</p> <p>Strong sources of electromagnetic interference (EMI) can cause:</p> <ul style="list-style-type: none"> <li>• Destruction of the signal drivers and receivers in the device</li> <li>• Electrical hazards as a result of power surges conducted over the lines into the equipment.</li> </ul>

## QFX5110 Chassis Grounding Cable and Lug Specifications

To ground a QFX5110, connect a grounding cable to earth ground and attach it to the chassis grounding points. See ["Connect the QFX5110 to Earth Ground" on page 121](#). However if you are unable to access the chassis grounding point on a DC system by using the two-holed grounding lug, you can ground the chassis using the DC protective earthing terminal on the DC power supply, see ["Alternate Method to Ground QFX5110-48S-DC and QFX5110-32Q-DC Systems" on page 123](#).



**WARNING:** To comply with GR-1089 requirements, all intra-building copper cabling used for SFP+ and QSFP+ ports must be shielded and grounded at both ends.



**CAUTION:** Before switch installation begins, a licensed electrician must attach a cable lug to the grounding cables that you supply. See ["Connect the QFX5110 to Earth Ground" on page 121](#). A cable with an incorrectly attached lug can damage the switch.

Before connecting the switch to earth ground, review the following information:



- The grounding lug required is a Panduit LCD10-10A-L or equivalent (not provided). The recommended grounding lug accommodates 14–10 AWG (2–5.3 mm<sup>2</sup>) stranded wire. If you are using the alternate method of grounding the chassis on a QFX5110-48S or QFX5110-32Q DC system, the recommended grounding cable is 12 AWG (2.5 mm<sup>2</sup>) standard wire, 90° C wire or heavier.
- The grounding cable must be 14 AWG (2 mm<sup>2</sup>), minimum 60° C wire, or as permitted by the local code (not provided).

## SEE ALSO

[QFX5110 Power System | 45](#)

[Maintaining QFX5110 Power Supplies | 144](#)

## QFX5110 Clearance Requirements for Airflow and Hardware Maintenance

When planning the site for installing a QFX5110, you must allow sufficient clearance around the installed chassis (see [Figure 32 on page 64](#)).

**Figure 32: Clearance Requirements for Airflow and Hardware Maintenance for a QFX5110**

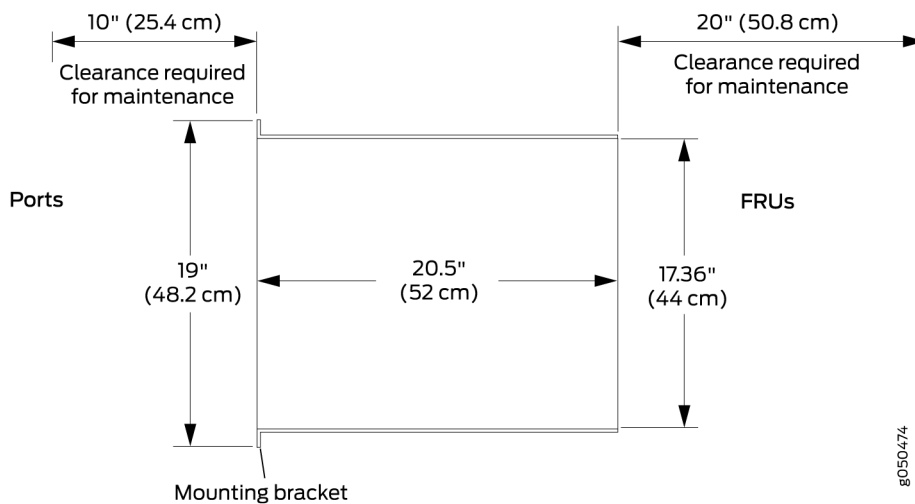

- For the cooling system to function properly, the airflow around the chassis must be unrestricted. See "[QFX5110 Cooling System and Airflow Description](#)" on page 38 for more information about the airflow through the chassis.

- If you are mounting a QFX5110 in a rack with other equipment, ensure that the exhaust from other equipment does not blow into the intake vents of the chassis.
- Leave at least 24 in. (61 cm) both in front of and behind the QFX5110. For service personnel to remove and install hardware components, you must leave adequate space at the front and back of the switch. NEBS GR-63 recommends that you allow at least 30 in. (76.2 cm) in front of the rack or cabinet and 24 in. (61 cm) behind the rack or cabinet.

## SEE ALSO

[QFX5110 Rack Requirements | 66](#)

[General Site Guidelines](#)

[Rack-Mounting and Cabinet-Mounting Warnings](#)

## QFX5110 Chassis Physical Specifications

The QFX5110 models are rigid sheet-metal structures that houses the hardware components. [Table 23 on page 65](#) summarizes the physical specifications of the QFX5110.

**Table 23: Physical Specifications for the QFX5110**

Product SKU	Height	Width	Depth	Weight
QFX5110-48S	1.72 in. (4.3 cm)	17.36 in. (44.1 cm)	20.48 in. (52.02 cm) excluding fan and power supply handles	23 lbs (10.43 kg) with 2 power supplies
QFX5110-32Q	1.72 in. (4.3 cm)	17.36 in. (44.1 cm)	20.48 in. (52.02 cm) excluding fan and power supply handles	24.6 lbs (11.16 kg) with 2 power supplies

## SEE ALSO

[QFX5110 Rack Requirements | 66](#)

[Mounting a QFX5110 in a Rack | 105](#)

[QFX5110 Installation Overview | 100](#)

## QFX5110 Rack Requirements

QFX5110 switches are designed to be installed on four-post racks.

Rack requirements consist of:

- Rack type
- Mounting bracket hole spacing
- Rack size and strength

[Table 24 on page 66](#) provides the rack requirements and specifications for the QFX5110.

**Table 24: Rack Requirements for the QFX5110**

Rack Requirement	Guidelines
Rack type	<p>Use a four-post rack that provides bracket holes or hole patterns spaced at 1 U (1.75 in. or 4.45 cm) increments and that meets the size and strength requirements to support the weight.</p> <p>A U is the standard rack unit defined in <i>Cabinets, Racks, Panels, and Associated Equipment</i> (document number EIA-310-D) published by the Electronics Industry Association.</p>
Mounting bracket hole spacing	<p>The holes in the mounting brackets are spaced at 1 U (1.75 in. or 4.45 cm), so that the switch can be mounted in any rack that provides holes spaced at that distance.</p>

Table 24: Rack Requirements for the QFX5110 (Continued)

Rack Requirement	Guidelines
Rack size and strength	<ul style="list-style-type: none"> <li>• Ensure that the rack complies with the standards for a 19-in. or 23-in. rack as defined in <i>Cabinets, Racks, Panels, and Associated Equipment</i> (document number EIA-310-D) published by the Electronics Industry Association.</li> <li>• A 600-mm rack as defined in the four-part <i>Equipment Engineering (EE); European telecommunications standard for equipment practice</i> (document numbers ETS 300 119-1 through 119-4) published by the European Telecommunications Standards Institute.</li> </ul> <p>The horizontal spacing between the rails in a rack that complies with this standard is usually wider than the device's mounting brackets, which measure 19 in. (48.26 cm) from outer edge to outer edge. Use approved wing devices to narrow the opening between the rails as required.</p> <ul style="list-style-type: none"> <li>• Ensure that the rack rails are spaced widely enough to accommodate the switch chassis' external dimensions. The outer edges of the front-mounting brackets extend the width to 19 in. (48.26 cm).</li> <li>• For four-post installations, the front and rear rack rails must be spaced between 23.5 in. (59.7 cm) to 30.6 in. (77.7 cm) front-to-back.</li> <li>• The rack must be strong enough to support the weight of the switch.</li> <li>• Ensure that the spacing of rails and adjacent racks allows for proper clearance around the switch and rack.</li> </ul>
Rack connection to building structure	<ul style="list-style-type: none"> <li>• Secure the rack to the building structure.</li> <li>• If earthquakes are a possibility in your geographical area, secure the rack to the floor.</li> <li>• Secure the rack to the ceiling brackets as well as wall or floor brackets for maximum stability.</li> </ul>

## RELATED DOCUMENTATION

Rack-Mounting and Cabinet-Mounting Warnings | 186

# QFX5110 Deployment in a Virtual Chassis or Virtual Chassis Fabric

## IN THIS SECTION

- [Planning a Virtual Chassis Deployment using QFX Devices | 68](#)
- [Virtual Chassis Fabric Hardware Overview | 75](#)
- [Plan a Virtual Chassis Fabric Deployment | 76](#)

## Planning a Virtual Chassis Deployment using QFX Devices

### IN THIS SECTION

- [Valid Configurations for a QFX Virtual Chassis | 69](#)
- [Valid Configurations for a QFX5110 Virtual Chassis | 70](#)
- [Valid Configurations for a QFX5200 Virtual Chassis | 70](#)
- [VC Deployment Checklist | 70](#)

You can deploy QFX Series switches as members in three types of Virtual Chassis:

- QFX Virtual Chassis (QFX3500, QFX3600, QFX5100, and EX4300)
- QFX5110 Virtual Chassis (QFX5110 and QFX5100)
- QFX5200 Virtual Chassis (QFX5200-32C only)

QFX Virtual Chassis and QFX5110 Virtual Chassis allow you to interconnect a mixture of up to ten switches into one logical device and manage the device as a single chassis. QFX5200 Virtual Chassis is limited to three QFX5200-32C members.

A Virtual Chassis configuration has two Routing Engines—the primary switch and the backup switch. All other participating switches operate as line cards. You create a Virtual Chassis by cabling the switches in a ring topology and configuring SFP+, QSFP+, or QSFP28 interfaces into Virtual Chassis ports (VCPs). VCPs are responsible for passing all data and control traffic between member switches in the Virtual Chassis. All non-channelized QSFP28 or QSFP+ uplink interfaces on the switches can be configured into VCPs. All fixed SFP+ interfaces can also be configured into VCPs.

All members of the Virtual Chassis are required to run the same Junos OS Release. You can check the version and release by issuing the `show chassis version` CLI command.

This topic covers:

## Valid Configurations for a QFX Virtual Chassis

Valid configurations are:

- All QFX5100 members (homogenous)—Supported QFX5100 models are:
  - QFX5100-24Q
  - QFX5100-48S
  - QFX5100-48T
  - QFX5100-96S
- All QFX3600 members (homogenous)
- All QFX3500 members (homogenous)
- A mixture of QFX3600 and QFX3500 members (heterogeneous)
- A mixture of QFX5100, QFX3600, and QFX3500 members (heterogeneous)—use the QFX5100 switches as primary RE and backup RE whenever possible.
- A mixture of QFX5100, QFX3600, QFX3500, and EX4300 members (heterogeneous). EX4300 switches as the primary RE or backup RE is not supported; use QFX5100 switches in these roles whenever possible.

An all EX4300 member is simply considered an EX4300 Virtual Chassis. See [Understanding EX Series Virtual Chassis](#).

If the QSFP+ interfaces are not available for VCP, 10-Gigbit interfaces can be used.

## Valid Configurations for a QFX5110 Virtual Chassis

Valid configurations are:

- All QFX5110 members (homogenous)–Supported QFX5110 models are:
  - QFX5110-32Q
  - QFX5110-48S
- A mixture of QFX5110 and QFX5100 members (homogenous)–use the QFX5110 models as the primary RE and backup RE. Use the following QFX5100 switches in the line card role:
  - QFX5100-24Q
  - QFX5100-48S
  - QFX5100-48T
  - QFX5100-96S

## Valid Configurations for a QFX5200 Virtual Chassis

You can create an all QFX5200-32C Virtual Chassis with up to three members. Use the QFX5200-32C in all three member roles: primary RE, backup RE, and line card. Configure the Virtual Chassis Ports (VCPs) as 40-Gigabit Ethernet only. QFX5200-48Y is not supported in a QFX5200 Virtual Chassis.

## VC Deployment Checklist

Use [Table 25 on page 70](#) to plan your deployment:

**Table 25: Deployment Checklist**

Item or Task	For More Information	Performed By	Date
<b>Components</b>			

Table 25: Deployment Checklist (*Continued*)

Item or Task	For More Information	Performed By	Date
<p>Determine the number of devices in the Virtual Chassis and the role of each device (primary RE, backup RE, or linecard).</p> <p><b>NOTE:</b> A Virtual Chassis is not constrained to a single building; the limits for the optic cable are the only consideration.</p>	<p><a href="#">Understanding QFX Series Virtual Chassis</a></p> <p><a href="#">Understanding Virtual Chassis Components</a></p>		
<b>Environment</b>			
<p>Evaluate the provisioning options and determine the configuration method that applies to your deployment.</p>	<p><a href="#">Configuring an EX4650 or a QFX Series Virtual Chassis</a></p>		
<b>Power</b>			
<p>Measure the distance between external power sources and switch installation site.</p>			



Table 25: Deployment Checklist *(Continued)*

Item or Task	For More Information	Performed By	Date
Calculate the power consumption and requirements.	<p data-bbox="597 365 1024 428">"QFX5110 AC Power Specifications" on page 47</p> <p data-bbox="597 459 1024 522"><i>AC Power Specifications for a QFX5100 Device</i></p> <p data-bbox="597 554 1024 617"><i>AC Power Specifications for a QFX3600 or QFX3600-I Device</i></p> <p data-bbox="597 648 1024 711"><i>AC Power Specifications for a QFX3500 Device</i></p> <p data-bbox="597 743 1024 806"><i>AC Power Specifications for an EX4600 Switch</i></p> <p data-bbox="597 837 1024 900"><i>AC Power Supply Specifications for EX4300 Switches</i></p>		
<b>Rack or Cabinet</b>			

Table 25: Deployment Checklist *(Continued)*

Item or Task	For More Information	Performed By	Date
Verify that your rack or cabinet meets the minimum requirements for the installation of the switch.	<p data-bbox="597 365 1023 426">"QFX5110 Rack Requirements" on page 66</p> <p data-bbox="597 459 967 520"><i>Rack Requirements for a QFX5100 Device</i></p> <p data-bbox="597 554 1000 615"><i>Cabinet Requirements for a QFX5100 Device</i></p> <p data-bbox="597 648 997 709"><i>Rack Requirements for a QFX3600 or QFX3600-I Device</i></p> <p data-bbox="597 743 1027 804"><i>Cabinet Requirements for a QFX3600 or QFX3600-I Device</i></p> <p data-bbox="597 837 967 898"><i>Rack Requirements for a QFX3500 Device</i></p> <p data-bbox="597 932 1000 993"><i>Cabinet Requirements for a QFX3500 Device</i></p> <p data-bbox="597 1026 963 1087"><i>Rack Requirements for an EX4600 Switch</i></p> <p data-bbox="597 1121 992 1182"><i>Cabinet Requirements for an EX4600 Switch</i></p> <p data-bbox="597 1215 1024 1247"><i>Rack Requirements for a EX4300 Device</i></p> <p data-bbox="597 1281 980 1341"><i>Cabinet Requirements for a EX4300 Device</i></p>		

Table 25: Deployment Checklist (*Continued*)

Item or Task	For More Information	Performed By	Date
Plan rack or cabinet location, including required space clearances.	<p><i>Clearance Requirements for Airflow and Hardware Maintenance for a QFX5100 Device</i></p> <p><i>Clearance Requirements for Airflow and Hardware Maintenance for a QFX3600 or QFX3600-I Device</i></p> <p><i>Clearance Requirements for Airflow and Hardware Maintenance for a QFX3500 Device</i></p> <p><i>Clearance Requirements for Airflow and Hardware Maintenance for an EX4600 Switch</i></p> <p><i>Clearance Requirements for Airflow and Hardware Maintenance for EX4300 Switches</i></p>		
Secure the rack or cabinet to the floor and building structure.			
<b>Cables</b>			
<p>Acquire cables and connectors:</p> <ul style="list-style-type: none"> <li>• Determine the number of cables needed based on your planned configuration.</li> <li>• Review the maximum distance allowed for each cable. Choose the length of cable based on the distance between the hardware components being connected.</li> </ul>	<ul style="list-style-type: none"> <li>• <i>Cable Specifications for QSFP+ and QSFP28 Transceivers</i></li> <li>• <i>Cable Specifications for Console and Management Connections for the QFX Series</i></li> <li>• <i>Understanding EX Series Switches Fiber-Optic Cable Signal Loss, Attenuation, and Dispersion</i></li> <li>• <i>Understanding QFX Series Fiber-Optic Cable Signal Loss, Attenuation, and Dispersion</i></li> </ul>		

**Table 25: Deployment Checklist (Continued)**

Item or Task	For More Information	Performed By	Date
Plan the cable routing and management.			

**SEE ALSO**

[QFX5110 Site Preparation Checklist | 58](#)

*Site Preparation Checklist for a QFX5100 Device*

*Site Preparation Checklist for a QFX3600 or QFX3600-I Device*

*Site Preparation Checklist for a QFX3500 Device*

*Site Preparation Checklist for EX4300 Switches*

## Virtual Chassis Fabric Hardware Overview

The Juniper Networks Virtual Chassis Fabric (VCF) spine-and-leaf architecture supports two types of hardware configurations based on the switch model used as the spine in the VCF.

- QFX5110 VCF
  - QFX5110-32Q (spine or leaf)
  - QFX5110-48S (leaf)
  - QFX5100-24Q (leaf)
  - QFX5100-48S (leaf)
  - QFX5100-48T (leaf)

**NOTE:** Available on Junos OS Release 17.3R2 and later.

- QFX5100-96S (leaf)
- QFX5100 VCF

- QFX5100-24Q (spine or leaf)
- QFX5100-48S (spine or leaf)
- QFX5100-48T (leaf)
- QFX5100-96S (leaf)
- QFX3600 (leaf)
- QFX3500 (leaf)
- EX4300 (leaf)

Homogeneous configurations are Installations with all members within the same line of switches (for example, QFX5100-24Q, QFX5100-48S, QFX5100-48T, and QFX5100-96S in a QFX5100 VCF). QFX5100 VCF installations with a mixture of models are called *mixed mode*. For example, a mixed mode QFX5100 VCF might contain a EX4300 or QFX3600 as leaf devices. Mixed mode devices must be configured before joining the VCF and are not eligible for the auto-provisioned configuration (plug and play). Adding a device configured as mixed mode to a VCF can cause those devices to be marked inactive if the other devices are not also configured as mixed mode. In both mixed mode and homogeneous configurations, you must run the same Junos OS release on all devices. In a QFX5100 VCF, the optimum configuration comprises only QFX5100 models. When both the QFX5100-24Q and the QFX5100-48S are available in a VCF, use the QFX5100-24Q as the spine.

In a QFX5110 VCF, the optimum configuration comprises only QFX5110 models. When multiple models of QFX5110 are in a VCF, use the QFX5110-32Q as the spine. All QFX5110 VCF configurations are considered homogeneous.

## SEE ALSO

| [Virtual Chassis Fabric Installation Overview](#)

## Plan a Virtual Chassis Fabric Deployment

A Virtual Chassis Fabric (VCF) architecture supports up to 20 interconnected devices that are managed as a logical single device. Supported platforms vary depending on the QFX Series switch chosen for the spine. See [Understanding Virtual Chassis Fabric Components](#) and "[Virtual Chassis Fabric Hardware Overview](#)" on page 75 for supported configurations. Although the architecture has a powerful auto-provisioning option, which allows you to plug and play the devices, careful planning of the deployment can avoid unexpected results.

For example, if you perform any configuration level commands on one of the devices (including assigning IP addresses or host names) you no longer can use auto-provisioning.

Use the following checklist to plan your deployment:

**Table 26: Deployment Checklist**

Item or Task	For More Information	Performed By	Date
<b>Components</b>			
<p>Determine the number of devices in the VCF and the role of each device.</p> <p><b>NOTE:</b> A VCF is not constrained to a single building; the limits for the optic cable are the only consideration.</p>	<p><i><a href="#">Understanding Virtual Chassis Fabric Components</a></i></p>		
<b>Environment</b>			
<p>Evaluate the provisioning options and determine the configuration method that applies to your deployment.</p>	<p><i><a href="#">Understanding Virtual Chassis Fabric Configuration</a></i></p>		
<b>Power</b>			
<p>Measure the distance between external power sources and switch installation site.</p>			

Table 26: Deployment Checklist (*Continued*)

Item or Task	For More Information	Performed By	Date
Calculate the power consumption and requirements.	<p data-bbox="630 363 1019 428">"QFX5110 AC Power Specifications" on page 47</p> <p data-bbox="630 459 946 525"><i>AC Power Specifications for a QFX5100 Device</i></p> <p data-bbox="630 556 972 621"><i>AC Power Specifications for a QFX3600 or QFX3600-I Device</i></p> <p data-bbox="630 653 946 718"><i>AC Power Specifications for a QFX3500 Device</i></p> <p data-bbox="630 749 1008 814"><i>AC Power Supply Specifications for EX4300 Switches</i></p>		
<b>Rack or Cabinet</b>			
Verify that your rack or cabinet meets the minimum requirements for the installation of the switch.	<p data-bbox="630 955 997 1020">"QFX5110 Rack Requirements" on page 66</p> <p data-bbox="630 1052 1002 1117"><i>Rack Requirements for a QFX5100 Device</i></p> <p data-bbox="630 1148 1034 1213"><i>Cabinet Requirements for a QFX5100 Device</i></p> <p data-bbox="630 1245 1031 1310"><i>Rack Requirements for a QFX3600 or QFX3600-I Device</i></p> <p data-bbox="630 1341 1034 1407"><i>Cabinet Requirements for a QFX3600 or QFX3600-I Device</i></p> <p data-bbox="630 1438 1002 1503"><i>Rack Requirements for a QFX3500 Device</i></p> <p data-bbox="630 1535 1034 1600"><i>Cabinet Requirements for a QFX3500 Device</i></p> <p data-bbox="630 1631 964 1696"><i>Rack Requirements for EX4300 Switches</i></p> <p data-bbox="630 1728 997 1793"><i>Cabinet Requirements for EX4300 Switches</i></p>		

Table 26: Deployment Checklist (*Continued*)

Item or Task	For More Information	Performed By	Date
Plan rack or cabinet location, including required space clearances.	<p data-bbox="630 365 1008 464">"QFX5110 Clearance Requirements for Airflow and Hardware Maintenance" on page 64</p> <p data-bbox="630 495 1008 594"><i>Clearance Requirements for Airflow and Hardware Maintenance for a QFX5100 Device</i></p> <p data-bbox="630 625 1008 724"><i>Clearance Requirements for Airflow and Hardware Maintenance for a QFX3600 or QFX3600-I Device</i></p> <p data-bbox="630 756 1008 854"><i>Clearance Requirements for Airflow and Hardware Maintenance for a QFX3500 Device</i></p> <p data-bbox="630 886 1008 984"><i>Clearance Requirements for Airflow and Hardware Maintenance for EX4300 Switches</i></p>		
Secure the rack or cabinet to the floor and building structure.			
<b>Cables</b>			
<p data-bbox="232 1268 561 1297">Acquire cables and connectors:</p> <ul data-bbox="232 1329 597 1675" style="list-style-type: none"> <li data-bbox="232 1329 597 1428">• Determine the number of cables needed based on your planned configuration.</li> <li data-bbox="232 1459 597 1675">• Review the maximum distance allowed for each cable. Choose the length of cable based on the distance between the hardware components being connected.</li> </ul>	<p data-bbox="630 1268 1008 1329"><i>Cable Specifications for QSFP+ and QSFP28 Transceivers</i></p> <p data-bbox="630 1360 1008 1459"><i>Cable Specifications for Console and Management Connections for the QFX Series</i></p>		
Plan the cable routing and management.			



# QFX5110 Network Cable and Transceiver Planning

## IN THIS SECTION

- Determining Transceiver Support for the QFX5110 | 80
- Cable Specifications for QSFP+, QSFP28, and QSFP-DD Transceivers | 81
- Understanding QFX Series Fiber-Optic Cable Signal Loss, Attenuation, and Dispersion | 83
- Calculating Power Budget and Power Margin for Fiber-Optic Cables | 85

## Determining Transceiver Support for the QFX5110

The port panel of the QFX5110-48S supports 48 logical 10-Gigabit Ethernet ports. These data ports (0 through 47) support either 1-Gigabit small form-factor pluggable (SFP) or 10-Gigabit Ethernet Ethernet small form-factor pluggable plus (SFP+) transceivers. You can also use SFP+ DAC cables and 10-Gigabit active optical cables (AOC) in any access port.

The remaining 4 QSFP28 ports (48 through 51) support speeds of 40 Gbps or 100 Gbps. Each port can be configured as an independent 100-Gigabit Ethernet port or as an independent 40-Gigabit Ethernet port. These port are usually used as uplinks. In 40-Gigabit Ethernet mode, these ports can be channelized using QSP+ to SFP+ DAC breakout (DACBO) cables.

You can find information about the optical transceivers supported on your Juniper device by using the Hardware Compatibility Tool. In addition to transceiver and connection type, the optical and cable characteristics—where applicable—are documented for each transceiver. The Hardware Compatibility Tool enables you to search by product, displaying all the transceivers supported on that device, or category, by interface speed or type. The list of supported transceivers for the QFX5110 is located at <https://pathfinder.juniper.net/hct/product/#prd=QFX5110>.



**CAUTION:** The Juniper Networks Technical Assistance Center (JTAC) provides complete support for Juniper-supplied optical modules and cables. However, JTAC does not provide support for third-party optical modules and cables that are not qualified or supplied by Juniper Networks. If you face a problem running a Juniper device that uses third-party optical modules or cables, JTAC may help you diagnose host-related issues if the observed issue is not, in the opinion of JTAC, related to the use of the third-party optical modules or cables. Your JTAC engineer will likely request that you check the

third-party optical module or cable and, if required, replace it with an equivalent Juniper-qualified component.

Use of third-party optical modules with high-power consumption (for example, coherent ZR or ZR+) can potentially cause thermal damage to or reduce the lifespan of the host equipment. Any damage to the host equipment due to the use of third-party optical modules or cables is the users' responsibility. Juniper Networks will accept no liability for any damage caused due to such use.

## Cable Specifications for QSFP+, QSFP28, and QSFP-DD Transceivers

The 40-Gigabit Ethernet QSFP+, 100-Gigabit Ethernet QSFP28, and 400G (QDD-400G-DR4 and QDD-400G-SR4P2) transceivers that are used in QFX Series switches use 12-ribbon multimode fiber crossover cables with socket MPO-12 (UPC/APC) connectors. The fiber can be either OM3 or OM4. These cables are not sold by Juniper Networks.



**CAUTION:** To maintain agency approvals, use only a properly constructed, shielded cable.

**TIP:** Ensure that you order cables with the correct polarity. Vendors refer to these crossover cables as *key up to key up*, *latch up to latch up*, *Type B*, or *Method B*. If you are using patch panels between two QSFP+ or QSFP28 transceivers, ensure that the proper polarity is maintained through the cable plant.

[Table 27 on page 81](#) describes the signals on each fiber. [Table 28 on page 82](#) shows the pin-to-pin connections for proper polarity.

**Table 27: QSFP+ and QSFP28 Optical Module Receptacle Pinouts**

Fiber	Signal
1	Tx0 (Transmit)
2	Tx1 (Transmit)
3	Tx2 (Transmit)

Table 27: QSFP+ and QSFP28 Optical Module Receptacle Pinouts (*Continued*)

Fiber	Signal
4	Tx3 (Transmit)
5	Unused
6	Unused
7	Unused
8	Unused
9	Rx3 (Receive)
10	Rx2 (Receive)
11	Rx1 (Receive)
12	Rx0 (Receive)

Table 28: QSFP+ MPO Fiber-Optic Crossover Cable Pinouts

Pin	Pin
1	12
2	11
3	10
4	9
5	8

Table 28: QSFP+ MPO Fiber-Optic Crossover Cable Pinouts (*Continued*)

Pin	Pin
6	7
7	6
8	5
9	4
10	3
11	2
12	1

## Understanding QFX Series Fiber-Optic Cable Signal Loss, Attenuation, and Dispersion

### IN THIS SECTION

- [Signal Loss in Multimode and Single-Mode Fiber-Optic Cables | 84](#)
- [Attenuation and Dispersion in Fiber-Optic Cable | 84](#)

To determine the power budget and power margin needed for fiber-optic connections, you need to understand how signal loss, attenuation, and dispersion affect transmission. The QFX Series uses various types of network cables, including multimode and single-mode fiber-optic cables.

## Signal Loss in Multimode and Single-Mode Fiber-Optic Cables

Multimode fiber is large enough in diameter to allow rays of light to reflect internally (bounce off the walls of the fiber). Interfaces with multimode optics typically use LEDs as light sources. However, LEDs are not coherent light sources. They spray varying wavelengths of light into the multimode fiber, which reflect the light at different angles. Light rays travel in jagged lines through a multimode fiber, causing signal dispersion. When light traveling in the fiber core radiates into the fiber cladding (layers of lower refractive index material in close contact with a core material of higher refractive index), higher-order mode loss occurs. Together, these factors reduce the transmission distance of multimode fiber compared to that of single-mode fiber.

Single-mode fiber is so small in diameter that rays of light reflect internally through one layer only. Interfaces with single-mode optics use lasers as light sources. Lasers generate a single wavelength of light, which travels in a straight line through the single-mode fiber. Compared to multimode fiber, single-mode fiber has a higher bandwidth and can carry signals for longer distances. It is consequently more expensive.

For information about the maximum transmission distance and supported wavelength range for the types of single-mode and multimode fiber-optic cables that are connected to the QFX Series, see [the Hardware Compatibility Tool](#). Exceeding the maximum transmission distances can result in significant signal loss, which causes unreliable transmission.

## Attenuation and Dispersion in Fiber-Optic Cable

An optical data link functions correctly provided that modulated light reaching the receiver has enough power to be demodulated correctly. *Attenuation* is the reduction in strength of the light signal during transmission. Passive media components such as cables, cable splices, and connectors cause attenuation. Although attenuation is significantly lower for optical fiber than for other media, it still occurs in both multimode and single-mode transmission. An efficient optical data link must transmit enough light to overcome attenuation.

*Dispersion* is the spreading of the signal over time. The following two types of dispersion can affect signal transmission through an optical data link:

- Chromatic dispersion, which is the spreading of the signal over time caused by the different speeds of light rays.
- Modal dispersion, which is the spreading of the signal over time caused by the different propagation modes in the fiber.

For multimode transmission, modal dispersion, rather than chromatic dispersion or attenuation, usually limits the maximum bit rate and link length. For single-mode transmission, modal dispersion is not a factor. However, at higher bit rates and over longer distances, chromatic dispersion limits the maximum link length.

An efficient optical data link must have enough light to exceed the minimum power that the receiver requires to operate within its specifications. In addition, the total dispersion must be within the limits specified for the type of link in the Telcordia Technologies document GR-253-CORE (Section 4.3) and International Telecommunications Union (ITU) document G.957.

When chromatic dispersion is at the maximum allowed, its effect can be considered as a power penalty in the power budget. The optical power budget must allow for the sum of component attenuation, power penalties (including those from dispersion), and a safety margin for unexpected losses.

## Calculating Power Budget and Power Margin for Fiber-Optic Cables

### IN THIS SECTION

- [How to Calculate Power Budget for Fiber-Optic Cables | 85](#)
- [How to Calculate Power Margin for Fiber-Optic Cables | 86](#)

Use the information in this topic and the specifications for your optical interface to calculate the power budget and power margin for fiber-optic cables.

**TIP:** You can use the [Hardware Compatibility Tool](#) to find information about the pluggable transceivers supported on your Juniper Networks device.

To calculate the power budget and power margin, perform the following tasks:

### How to Calculate Power Budget for Fiber-Optic Cables

To ensure that fiber-optic connections have sufficient power for correct operation, you need to calculate the link's power budget, which is the maximum amount of power it can transmit. When you calculate the power budget, you use a worst-case analysis to provide a margin of error, even though all the parts of an actual system do not operate at the worst-case levels. To calculate the worst-case estimate of power budget ( $P_B$ ), you assume minimum transmitter power ( $P_T$ ) and minimum receiver sensitivity ( $P_R$ ):

$$P_B = P_T - P_R$$

The following hypothetical power budget equation uses values measured in decibels (dB) and decibels referred to one milliwatt (dBm):

$$P_B = P_T - P_R$$

$$P_B = -15 \text{ dBm} - (-28 \text{ dBm})$$

$$P_B = 13 \text{ dB}$$

## How to Calculate Power Margin for Fiber-Optic Cables

After calculating a link's power budget, you can calculate the power margin ( $P_M$ ), which represents the amount of power available after subtracting attenuation or link loss (LL) from the power budget ( $P_B$ ). A worst-case estimate of  $P_M$  assumes maximum LL:

$$P_M = P_B - LL$$

$P_M$  greater than zero indicates that the power budget is sufficient to operate the receiver.

Factors that can cause link loss include higher-order mode losses, modal and chromatic dispersion, connectors, splices, and fiber attenuation. [Table 29 on page 86](#) lists an estimated amount of loss for the factors used in the following sample calculations. For information about the actual amount of signal loss caused by equipment and other factors, refer to vendor documentation.

**Table 29: Estimated Values for Factors Causing Link Loss**

Link-Loss Factor	Estimated Link-Loss Value
Higher-order mode losses	Single mode—None Multimode—0.5 dB
Modal and chromatic dispersion	Single mode—None Multimode—None, if product of bandwidth and distance is less than 500 MHz-km
Faulty connector	0.5 dB
Splice	0.5 dB
Fiber attenuation	Single mode—0.5 dB/km Multimode—1 dB/km

The following sample calculation for a 2-km-long multimode link with a power budget ( $P_B$ ) of 13 dB uses the estimated values from [Table 29 on page 86](#). This example calculates link loss (LL) as the sum of fiber attenuation (2 km @ 1 dB/km, or 2 dB) and loss for five connectors (0.5 dB per connector, or 2.5 dB) and two splices (0.5 dB per splice, or 1 dB) as well as higher-order mode losses (0.5 dB). The power margin ( $P_M$ ) is calculated as follows:

$$P_M = P_B - LL$$

$$P_M = 13 \text{ dB} - 2 \text{ km (1 dB/km)} - 5 (0.5 \text{ dB}) - 2 (0.5 \text{ dB}) - 0.5 \text{ dB}$$

$$P_M = 13 \text{ dB} - 2 \text{ dB} - 2.5 \text{ dB} - 1 \text{ dB} - 0.5 \text{ dB}$$

$$P_M = 7 \text{ dB}$$

The following sample calculation for an 8-km-long single-mode link with a power budget ( $P_B$ ) of 13 dB uses the estimated values from [Table 29 on page 86](#). This example calculates link loss (LL) as the sum of fiber attenuation (8 km @ 0.5 dB/km, or 4 dB) and loss for seven connectors (0.5 dB per connector, or 3.5 dB). The power margin ( $P_M$ ) is calculated as follows:

$$P_M = P_B - LL$$

$$P_M = 13 \text{ dB} - 8 \text{ km (0.5 dB/km)} - 7(0.5 \text{ dB})$$

$$P_M = 13 \text{ dB} - 4 \text{ dB} - 3.5 \text{ dB}$$

$$P_M = 5.5 \text{ dB}$$

In both examples, the calculated power margin is greater than zero, indicating that the link has sufficient power for transmission and does not exceed the maximum receiver input power.

## RELATED DOCUMENTATION

[QFX5110 Port Panels | 21](#)

[QFX5110 Power System | 45](#)



# QFX5110 Management Cable Specifications and Pinouts

## IN THIS SECTION

- [Cable Specifications for Console and Management Connections for the QFX Series | 88](#)
- [RJ-45 Management Port Connector Pinout Information | 89](#)
- [Console Port Connector Pinouts for the QFX Series | 90](#)
- [RJ-45 Port, SFP Port, SFP+ Port, QSFP+ Port, and QSFP28 Port Connector Pinout Information | 91](#)
- [USB Port Specifications for the QFX Series | 98](#)

## Cable Specifications for Console and Management Connections for the QFX Series

[Table 30 on page 88](#) lists the specifications for the cables that connect the QFX Series switch to a management device.

**NOTE:** The QFX Series can be configured with small form-factor pluggable (SFP) management ports that support 1000BASE-SX transceivers. QFX5130 switches come with a RJ-45 management port, and support 10-Gbps speed. See the [Hardware Compatibility Tool](#) for more information about the fiber-optic cables required for use with these transceivers.

**Table 30: Cable Specifications for Console and Management Connections for the QFX Series**

Port on QFX Series Device	Cable Specification	Maximum Length	Device Receptacle
Console port	RS-232 (EIA-232) serial cable	7 feet (2.13 meters)	RJ-45
Management port	Category 5 cable or equivalent suitable for 1000BASE-T operation	328 feet (100 meters)	RJ-45

**NOTE:** We no longer include the RJ-45 console cable with the DB-9 adapter as part of the device package. If the console cable and adapter are not included in your device package, or if you need a different type of adapter, you can order the following separately:

- RJ-45 to DB-9 adapter (JNP-CBL-RJ45-DB9)
- RJ-45 to USB-A adapter (JNP-CBL-RJ45-USBA)
- RJ-45 to USB-C adapter (JNP-CBL-RJ45-USBC)

If you want to use RJ-45 to USB-A or RJ-45 to USB-C adapter you must have X64 (64-Bit) Virtual COM port (VCP) driver installed on your PC. See, <https://ftdichip.com/drivers/vcp-drivers/> to download the driver.

## RJ-45 Management Port Connector Pinout Information

Table 31 on page 89 provides the pinout information for the RJ-45 connector for the management port on Juniper Networks devices.

**Table 31: RJ-45 Management Port Connector Pinout Information**

Pin	Signal	Description
1	TRP1+	Transmit/receive data pair 1
2	TRP1-	Transmit/receive data pair 1
3	TRP2+	Transmit/receive data pair 2
4	TRP3+	Transmit/receive data pair 3
5	TRP3-	Transmit/receive data pair 3
6	TRP2-	Transmit/receive data pair 2

Table 31: RJ-45 Management Port Connector Pinout Information (*Continued*)

Pin	Signal	Description
7	TRP4+	Transmit/receive data pair 4
8	TRP4-	Transmit/receive data pair 4

## Console Port Connector Pinouts for the QFX Series

The console port (labeled **CON** or **CONSOLE**) is an RS-232 serial interface that uses an RJ-45 connector to connect to a console management device. The default baud rate for the console port is 9600 baud. You can also use a RJ45 to USB 2.0 Type-A cable and a RJ45 to USB 2.0 Type-C cable.

Table 32 on page 91 provides the pinout information for the RJ-45 console connector.

**NOTE:** If your laptop or PC does not have a DB-9 plug connector pin and you want to connect your laptop or PC directly to a QFX Series device, use a combination of an RJ-45 to DB-9 adapter and a USB to DB-9 plug adapter. You must provide the USB to DB-9 plug adapter.

**NOTE:** We no longer include the RJ-45 console cable with the DB-9 adapter as part of the device package. If the console cable and adapter are not included in your device package, or if you need a different type of adapter, you can order the following separately:

- RJ-45 to DB-9 adapter (JNP-CBL-RJ45-DB9)
- RJ-45 to USB-A adapter (JNP-CBL-RJ45-USBA)
- RJ-45 to USB-C adapter (JNP-CBL-RJ45-USBC)

If you want to use RJ-45 to USB-A or RJ-45 to USB-C adapter you must have X64 (64-Bit) Virtual COM port (VCP) driver installed on your PC. See, <https://ftdichip.com/drivers/vcp-drivers/> to download the driver.

**Table 32: Console Port Connector Pinouts for the QFX Series**

Pin	Signal	Description
3	TxD Output	Transmit data
4	Signal Ground	Signal ground
5	Signal Ground	Signal ground
6	RxD Input	Receive data
7	DCD Input	Data carrier detect

## RJ-45 Port, SFP Port, SFP+ Port, QSFP+ Port, and QSFP28 Port Connector Pinout Information

The tables in this topic describe the connector pinout information for the RJ-45, QSFP+, QSFP28, SFP+, and SFP ports.

- [Table 33 on page 91](#)—10/100/1000BASE-T Ethernet network port connector pinout information
- [Table 34 on page 92](#)—SFP network port connector pinout information
- [Table 35 on page 94](#)—SFP+ network port connector pinout information
- [Table 36 on page 95](#)—QSFP+ and QSFP28 network module ports connector pinout information

**Table 33: 10/100/1000BASE-T Ethernet Network Port Connector Pinout Information**

Pin	Signal	Description
1	TRP1+	Transmit/receive data pair 1 Negative Vport (in PoE models)

**Table 33: 10/100/1000BASE-T Ethernet Network Port Connector Pinout Information (Continued)**

Pin	Signal	Description
2	TRP1-	Transmit/receive data pair 1 Negative Vport (in PoE models)
3	TRP2+	Transmit/receive data pair 2 Positive Vport (in PoE models)
4	TRP3+	Transmit/receive data pair 3
5	TRP3-	Transmit/receive data pair 3
6	TRP2-	Transmit/receive data pair 2 Positive Vport (in PoE models)
7	TRP4+	Transmit/receive data pair 4
8	TRP4-	Transmit/receive data pair 4

**Table 34: SFP Network Port Connector Pinout Information**

Pin	Signal	Description
1	VeeT	Module transmitter ground
2	TX_Fault	Module transmitter fault
3	TX_Disable	Transmitter disabled
4	SDA	2-wire serial interface data line
5	SCL-	2-wire serial interface clock

Table 34: SFP Network Port Connector Pinout Information (Continued)

Pin	Signal	Description
6	MOD_ABS	Module absent
7	RS	Rate select
8	RX_LOS	Receiver loss of signal indication
9	VeeR	Module receiver ground
10	VeeR	Module receiver ground
11	VeeR	Module receiver ground
12	RD-	Receiver inverted data output
13	RD+	Receiver noninverted data output
14	VeeR	Module receiver ground
15	VccR	Module receiver 3.3 V supply
16	VccT	Module transmitter 3.3 V supply
17	VeeT	Module transmitter ground
18	TD+	Transmitter noninverted data input
19	TD-	Transmitter inverted data input
20	VeeT	Module transmitter ground

**Table 35: SFP+ Network Port Connector Pinout Information**

Pin	Signal	Description
1	VeeT	Module transmitter ground
2	TX_Fault	Module transmitter fault
3	TX_Disable	Transmitter disabled
4	SDA	2-wire serial interface data line
5	SCL-	2-wire serial interface clock
6	MOD_ABS	Module absent
7	RS0	Rate select 0, optionally controls SFP+ module receiver
8	RX_LOS	Receiver loss of signal indication
9	RS1	Rate select 1, optionally controls SFP+ transmitter
10	VeeR	Module receiver ground
11	VeeR	Module receiver ground
12	RD-	Receiver inverted data output
13	RD+	Receiver noninverted data output
14	VeeR	Module receiver ground
15	VccR	Module receiver 3.3-V supply

**Table 35: SFP+ Network Port Connector Pinout Information (Continued)**

Pin	Signal	Description
16	VccT	Module transmitter 3.3-V supply
17	VeeT	Module transmitter ground
18	TD+	Transmitter noninverted data input
19	TD-	Transmitter inverted data input
20	VeeT	Module transmitter ground

**Table 36: QSFP+ and QSFP28 Network Port Connector Pinout Information**

Pin	Signal
1	GND
2	TX2n
3	TX2p
4	GND
5	TX4n
6	TX4p
7	GND
8	ModSelL
9	LPMoDe_Reset



Table 36: QSFP+ and QSFP28 Network Port Connector Pinout Information *(Continued)*

Pin	Signal
10	VccRx
11	SCL
12	SDA
13	GND
14	RX3p
15	RX3n
16	GND
17	RX1p
18	RX1n
19	GND
20	GND
21	RX2n
22	RX2p
23	GND
24	RX4n

Table 36: QSFP+ and QSFP28 Network Port Connector Pinout Information (Continued)

Pin	Signal
25	RX4p
26	GND
27	ModPrsL
28	IntL
29	VccTx
30	Vcc1
31	Reserved
32	GND
33	TX3p
34	TX3n
35	GND
36	TX1p
37	TX1n
38	GND

## USB Port Specifications for the QFX Series

The following Juniper Networks USB flash drives have been tested and are officially supported for the USB port in the QFX Series:

- RE-USB-1G-S—1-gigabyte (GB) USB flash drive (except QFX3100 Director device)
- RE-USB-2G-S—2-GB USB flash drive (except QFX3100 Director device)
- RE-USB-4G-S—4-GB USB flash drive



**CAUTION:** Any USB memory product not listed as supported for the QFX Series has not been tested by Juniper Networks. The use of any unsupported USB memory product could expose your device to unpredictable behavior. Juniper Networks Technical Assistance Center (JTAC) can provide only limited support for issues related to unsupported hardware. We strongly recommend that you use only supported USB flash drives.



**CAUTION:** Remove the USB flash drive before upgrading Junos OS or rebooting a QFX Series device. Failure to do so could expose your device to unpredictable behavior.

**NOTE:** Executing the `request system snapshot` CLI command on a QFX3500 device requires an external USB flash drive with at least 4 GB of free space. We recommend using the RE-USB-4G-S flash drive.

**NOTE:** USB flash drives used with the QFX Series device must support USB 2.0 or later.

### RELATED DOCUMENTATION

*Connecting a QFX Series Device to a Management Console*

# 4

CHAPTER

## Initial Installation and Configuration

---

[QFX5110 Installation Overview | 100](#)

[Unpacking and Mounting the QFX5110 | 103](#)

[Connecting the QFX5110 to External Devices | 118](#)

[Connecting the QFX5110 to Power | 121](#)

[Connecting the QFX5110 in a Virtual Chassis or Virtual Chassis Fabric | 132](#)

[Configuring a QFX5110 | 136](#)

---

# QFX5110 Installation Overview

## IN THIS SECTION

- [Standalone Installation Overview | 100](#)
- [Virtual Chassis Fabric Installation Overview | 101](#)
- [QFX5110 Installation Safety Guidelines | 102](#)

## Standalone Installation Overview

You can mount a QFX5110:

- Flush with the front of a 19-in. four-post rack. Use the standard mounting brackets provided with the switch for this configuration.
- Recessed 2 in. (5 cm) from the front of a 19-in. four-post rack. Use the extension bracket provided in the standard mounting kit for this configuration.

To install and connect a QFX5110:

1. Follow the instructions in ["Unpacking a QFX5110" on page 103](#).
2. Determine how the switch is to be mounted.

Flush or recessed-mounted in a rack, see ["Mounting a QFX5110 in a Rack" on page 105](#) .

3. Follow the instructions in:
  - a. ["Connect the QFX5110 to Earth Ground" on page 121](#)
  - b. ["Connecting the QFX5110 to Power" on page 121](#)
  - c. ["Register Products—Mandatory to Validate SLAs" on page 105](#)
4. Follow the instructions in ["Configuring a QFX5110" on page 136](#).

## Virtual Chassis Fabric Installation Overview

For best results, ensure you review and understand the Virtual Chassis Fabric (VCF) configuration options. These configuration options are explained in "[Virtual Chassis Fabric Hardware Overview](#)" on [page 75](#) and [Understanding Virtual Chassis Fabric Configuration](#). Do not interconnect the switches with cables until directed in the procedure.

1. Install the individual switches in a rack or cabinet following the guidelines in [Plan a Virtual Chassis Fabric Deployment](#).

**BEST PRACTICE:** Install spine devices at the top of the rack or cabinet in order of primary routing engine (RE), backup RE, and then other leaf devices.

2. Make a list of all of the serial numbers of the devices.
3. Log into each device and configure into fabric mode and mixed mode, if needed. Mixed mode is only necessary for QFX5100 VCF when QFX5100-96S, QFX5100-48T, QFX3500, QFX3600, or EX4300 devices are present as leaf devices in the configuration. If a spine device is not properly configured in fabric and mixed mode for QFX5100 mixed VCF, the VCF devices reboot to commit the mixed mode or fabric settings. When fabric and mixed mode are not set, you might need to manually correct any issues that are related to the VCF not forming correctly because the device did not immediately join the VCF.



**WARNING:** Only configure operational-level commands. If you commit any configuration-level commands (including assigning IP address), the Virtual Chassis Fabric cannot form and the switch must be zeroed.

4. Configure the VCF into mixed mode if it is a QFX5100 VCF and the switch models span different lines of switches.
5. Configure each device for one of the provisioning modes: autoprovision, preprovision, or nonprovision. See:
  - [Autoprovisioning a Virtual Chassis Fabric](#)
  - [Preprovisioning a Virtual Chassis Fabric](#)
  - [Configuring a Nonprovisioned Virtual Chassis Fabric](#)
6. Connect and configure one of the management ports (C0) or (C1) to a management switch as the Virtual Management Ethernet interface. Using this interface, you can configure and manage the devices in the VCF. See "[Connect a Device to a Network for Out-of-Band Management](#)" on [page 118](#).
7. Commit your changes.

8. Cable the ports that you will use as VCPs. For cabling examples, see ["Connecting QFX5110 in a QFX5110 Virtual Chassis Fabric"](#) on page 134, [Connecting a QFX5100 Device in a Virtual Chassis Fabric](#), [Connecting a QFX3500 or QFX3600 Switch in a QFX5100 Virtual Chassis Fabric](#), and [Connecting EX Series Switches in a QFX5100 Virtual Chassis Fabric](#).

If you configured your devices as either autoprovisioned or preprovisioned, the Virtual Chassis ports (VCP) are automatically configured. If you configure the devices as nonprovisioned, you must manually configure the VCPs.

## QFX5110 Installation Safety Guidelines

The weight of a QFX5110-48S with fans and power supplies is approximately 23 lbs (10.43 kg). Observe the following guidelines for lifting and moving a QFX5110:



**CAUTION:** If you are installing the QFX5110 above 60 in. (152.4 cm) from the floor, either remove the power supplies, fan modules, and any expansion modules before attempting to install the switch, or ask someone to assist you during the installation.

- Before installing a QFX5110, read the guidelines in ["QFX5110 Site Preparation Checklist"](#) on page 58 to verify that the intended site meets the specified power, environmental, and clearance requirements.
- Before lifting or moving the QFX5110, disconnect all external cables.
- As when lifting any heavy object, lift most of the weight with your legs rather than your back. Keep your knees bent and your back relatively straight and avoid twisting your body as you lift. Balance the load evenly and be sure that your footing is solid.

### RELATED DOCUMENTATION

[General Site Guidelines](#) | 61

[Installation Instructions Warning](#) | 183

[Virtual Chassis Fabric Hardware Overview](#) | 75

# Unpacking and Mounting the QFX5110

## IN THIS SECTION

- Unpacking a QFX5110 | 103
- Register Products—Mandatory to Validate SLAs | 105
- Mounting a QFX5110 in a Rack | 105

## Unpacking a QFX5110

The QFX5110 is a rigid sheet-metal structure that houses the hardware components. A QFX5110 is shipped in a cardboard carton, secured with foam packing material. The carton also contains an accessory box and a Documentation Roadmap card.



**CAUTION:** The QFX5110 is maximally protected inside the shipping carton. Do not unpack the switch until you are ready to begin installation.

To unpack a QFX5110:

1. Move the shipping carton to a staging area as close to the installation site as possible, but where you have enough room to remove the system components.
2. Position the carton so that the arrows are pointing up.
3. Open the top flaps on the shipping carton.
4. Remove the accessory box and verify the contents against the inventory included in the box. [Table 37 on page 104](#) lists the inventory of components supplied with a QFX5110.
5. Pull out the packing material holding the switch in place.
6. Verify the chassis components received:
  - Two power supplies
  - Five fan modules

The QFX5110-32Q-CHAS is shipped without power supplies or fan modules.

7. Save the shipping carton and packing materials in case you need to move or ship the switch later.



**Table 37: Inventory of Components Supplied with a QFX5110**

Component	Quantity
Chassis	1
Fan modules	5
<p>Power supplies (650 W)</p> <ul style="list-style-type: none"> <li>• JPSU-650W-AC-AFO</li> <li>• JPSU-650W-AC-AFI</li> <li>• JPSU-650W-DC-AFO</li> <li>• JPSU-650W-DC-AFI</li> </ul> <p>AC systems ship with 2 country-specific C13 power cables.</p>	2
<p>Rack mount kit - JNP-4PST-RMK-1U-E (Partial toolless RMK)</p> <p>JNP-4PST-RMK-1U-E rack mount kit consists of the following parts:</p> <ul style="list-style-type: none"> <li>• A pair of front and rear-mounting rails</li> <li>• A pair of mounting brackets</li> <li>• 16 flat-head M4 x 6mm Phillips screws</li> </ul> <p>Spare rack mount kit order number - JNP-4PST-RMK-1U-E</p>	1
Rack mount assembly drawing	1
Documentation roadmap card	1
Warranty	1

**NOTE:** We no longer include the RJ-45 console cable with the DB-9 adapter as part of the device package. If the console cable and adapter are not included in your device package, or if you need a different type of adapter, you can order the following separately:

- RJ-45 to DB-9 adapter (JNP-CBL-RJ45-DB9)
- RJ-45 to USB-A adapter (JNP-CBL-RJ45-USBA)
- RJ-45 to USB-C adapter (JNP-CBL-RJ45-USBC)

If you want to use RJ-45 to USB-A or RJ-45 to USB-C adapter you must have X64 (64-Bit) Virtual COM port (VCP) driver installed on your PC. See, <https://ftdichip.com/drivers/vcp-drivers/> to download the driver.

## Register Products—Mandatory to Validate SLAs

Register all new Juniper Networks hardware products and changes to an existing installed product using the Juniper Networks website to activate your hardware replacement service-level agreements (SLAs).



**CAUTION:** Register product serial numbers on the Juniper Networks website. Update the installation base data if any addition or change to the installation base occurs or if the installation base is moved. Juniper Networks is not responsible for not meeting the hardware replacement service-level agreement for products that do not have registered serial numbers or accurate installation base data.

Register your product(s) at <https://tools.juniper.net/svcreg/SRegSerialNum.jsp>.

Update your installation base at <https://www.juniper.net/customers/csc/management/updateinstallbase.jsp>.

## Mounting a QFX5110 in a Rack

### IN THIS SECTION

- Before You Begin Rack Installation | 106
- Mount a QFX5110 in a Rack or Cabinet by Using the JNP-4PST-RMK-1U-E Rack Mount Kit | 107

You can mount a QFX5110 on a four-post 19-in. rack using the mounting kit provided with the switch.

Space the front and rear rack rails between 23.5 in. (59.7 cm) to 30.6 in. (77.7 cm) front-to-back.

This topic describes:

## Before You Begin Rack Installation

Before you begin mounting a QFX5110 switch in the rack:

1. Ensure that you understand how to prevent electrostatic discharge (ESD) damage. See [Prevention of Electrostatic Discharge Damage](#).
2. Verify that the site meets the requirements described in "[QFX5110 Site Preparation Checklist](#)" on [page 58](#).
3. Place the rack in its permanent location, allowing adequate clearance for airflow and maintenance, and secure it to the building structure.
4. Read [General Site Guidelines](#), and the "[QFX5110 Installation Safety Guidelines](#)" on [page 102](#).
5. Remove the switch from the shipping carton.
6. Ensure that you have the following parts and tools available to mount the switch in a rack:
  - ESD grounding strap (not provided).
  - Rack Mount Kit (provided).
  - Appropriate screwdriver for the mounting screws (not provided).
  - Two power cords with plugs appropriate to your geographical location (provided).
  - RJ-45 cable and RJ-45 to DB-9 serial port adapter (not provided).

**NOTE:** We no longer include the RJ-45 console cable with the DB-9 adapter as part of the device package. If the console cable and adapter are not included in your device package, or if you need a different type of adapter, you can order the following separately:

- RJ-45 to DB-9 adapter (JNP-CBL-RJ45-DB9)
- RJ-45 to USB-A adapter (JNP-CBL-RJ45-USBA)
- RJ-45 to USB-C adapter (JNP-CBL-RJ45-USBC)

If you want to use RJ-45 to USB-A or RJ-45 to USB-C adapter you must have X64 (64-Bit) Virtual COM port (VCP) driver installed on your PC. See, <https://ftdichip.com/drivers/vcp-drivers/> to download the driver.

- Management host, such as a PC laptop, with a serial port (not provided).

Optional equipment: grounding cable kit with bracket, lug, and two screws and washers.



**CAUTION:** All QFX5110 switches require two people for installation, one person to lift the switch into place and another person to attach the switch to the rack. If you are installing the QFX5110 above 60 in. (152.4 cm) from the floor, you can remove the power supplies and fan modules to minimize the weight before attempting to install the switch.



**CAUTION:** If you are mounting multiple switches on a rack, mount the switch in the lowest position of the rack first. Proceed to mount the rest of the switches from the bottom to the top of the rack to minimize the risk of the rack toppling.

## Mount a QFX5110 in a Rack or Cabinet by Using the JNP-4PST-RMK-1U-E Rack Mount Kit

### IN THIS SECTION

- [Mount the Device by Using the JNP-4PST-RMK-1U-E Rack Mount Kit On a Square Hole Rack | 107](#)
- [Mount the Device by Using the JNP-4PST-RMK-1U-E Rack Mount Kit On a Threaded Hole Rack | 112](#)

You can mount the QFX5110 switches on a square hole or threaded hole four-post 19-in. racks using the partial tool less JNP-4PST-RMK-1U-E rack mount kit which is available as a spare.

JNP-4PST-RMK-1U-E rack mount kit consists of the following parts:

- A pair of front and rear mounting rails
- A pair of mounting brackets
- 16 flat head M4 x 6mm Phillips screws

A four-post installation evenly supports the device by all four corners.

### Mount the Device by Using the JNP-4PST-RMK-1U-E Rack Mount Kit On a Square Hole Rack

Ensure that you have the following tools and parts available:

- An ESD grounding strap—not provided.
- Number 2 Phillips (+) screwdriver—not provided

- A pair of front and rear mounting rails that attach to the rack posts—provided with the rack mount kit
- A pair of mounting brackets and 16 flat head M4 x 6mm Phillips screws. These brackets attach to the device if not pre-installed—provided with the rack mount kit

To mount the device on four posts in a rack by using the JNP-4PST-RMK-1U-E rack mount kit:

1. Wrap and fasten the ESD grounding strap to your bare wrist and then connect the other end of the strap to the ESD point on the device.
2. Assemble the mounting rails.
  - a. Slide the rear floating bracket into the front bracket. See Figure 1.

**Figure 33: Assemble the Mounting Rails**

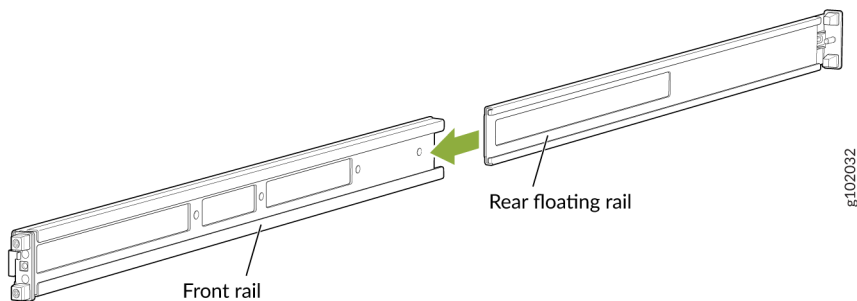

- b. Mounting rails assembled. See Figure 2.

**Figure 34: Front and Rear Rails Assembled**

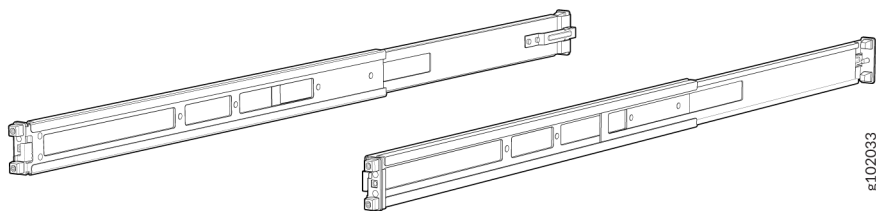

3. Attach the mounting rails to the rack.
  - a. Align the guide blocks of the rear mounting rails with the rear-post holes. Pull the rear mounting rails toward the front of the rack to lock the rails in place. You will hear a click sound when the latch locks into the corresponding rack holes. See Figure 3.

**Figure 35: Install the Rear Floating Rails**

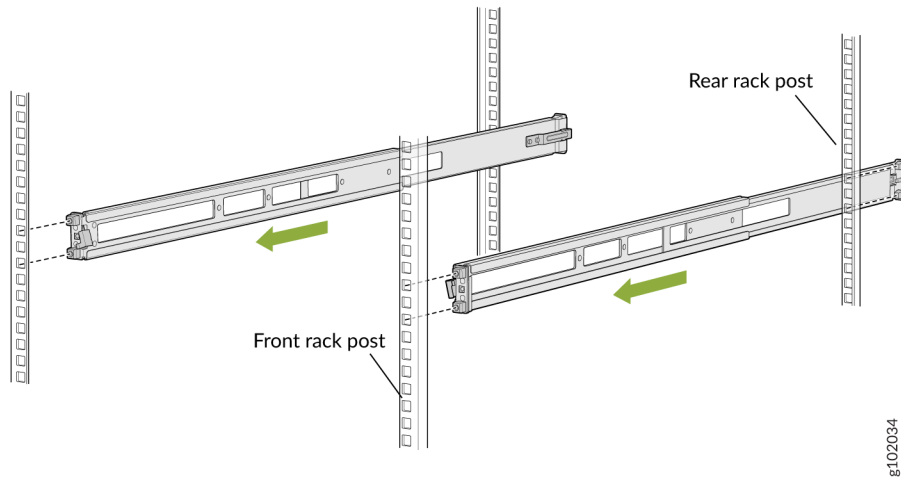

- b. Move the latch lock on the front mounting rails to open position, slide the front mounting rails, and insert the guide blocks into the front rack posts. See Figure 4.

**Figure 36: Install the Front Mounting Rails**

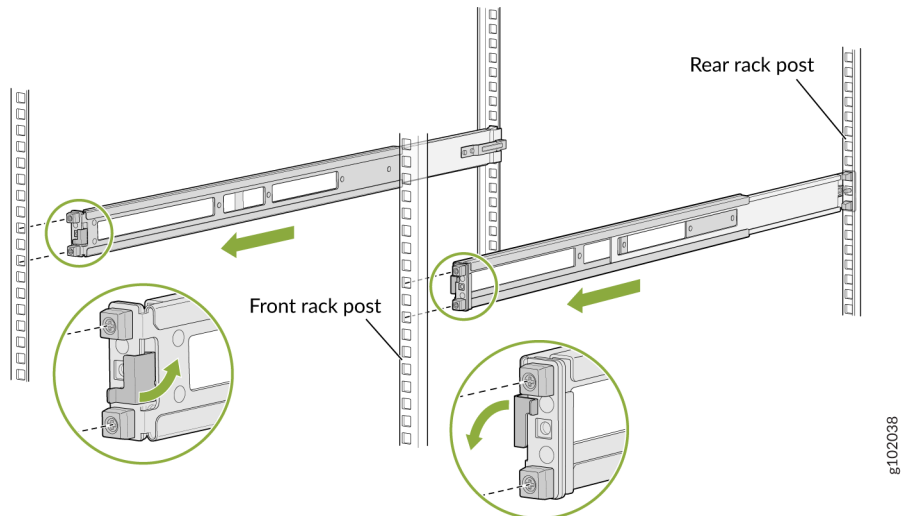

- c. Push the lock latch to the locked position. See Figure 5.

**Figure 37: Front Mounting Rails Lock Latch**

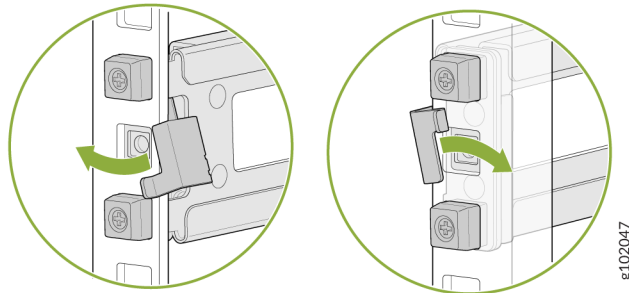

- d. Visually ensure that the front and rear latches are locked into place on the mounting rails. See Figure 6.

**Figure 38: Mounting Rails Installed and Locked**

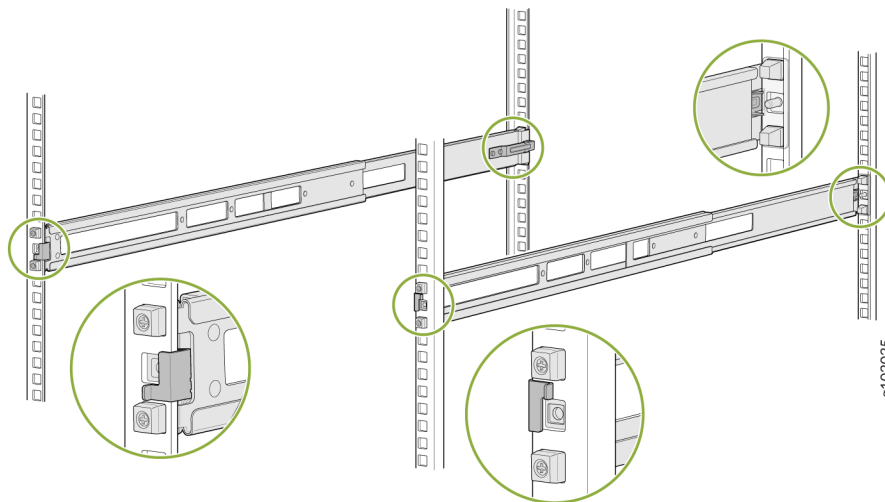

4. Attach mounting brackets to the device if not pre-installed. If your device already has the mounting brackets pre-installed than skip this step and move to the next step.
  - a. Align the holes on the mounting bracket with the screw holes on the side panel of the chassis.
  - b. Insert the flat head M4 x 6mm Phillips screws to attach the mounting bracket into the aligned holes on the chassis (see Figure 7). Tighten the screws.

Figure 39: Attach the Mounting Brackets to the Device

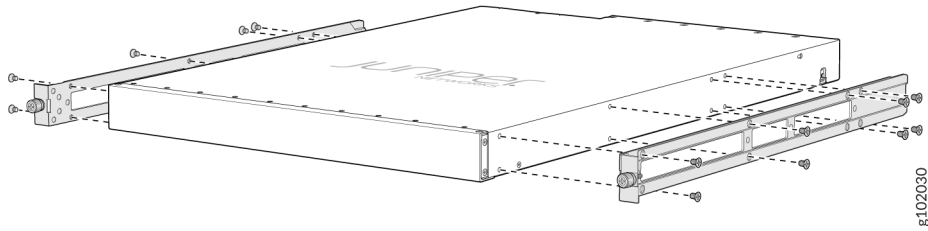

5. Position the device in such a manner that the **AIR OUT** labels on components are next to the hot aisle.
6. Grasp both sides of the device, lift it, and position the device such that the mounting rails slide into the channels of the mounting brackets. See Figure 8.

Figure 40: Slide the Device into the Rack

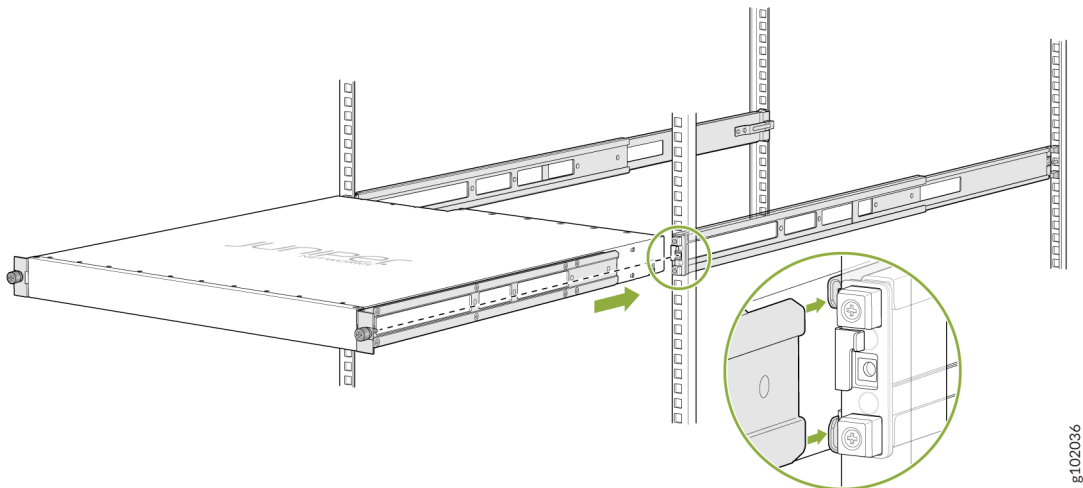

7. Tighten the two thumbscrews to secure the device. See Figure 9.



**Figure 41: Tighten the Thumb Screws**

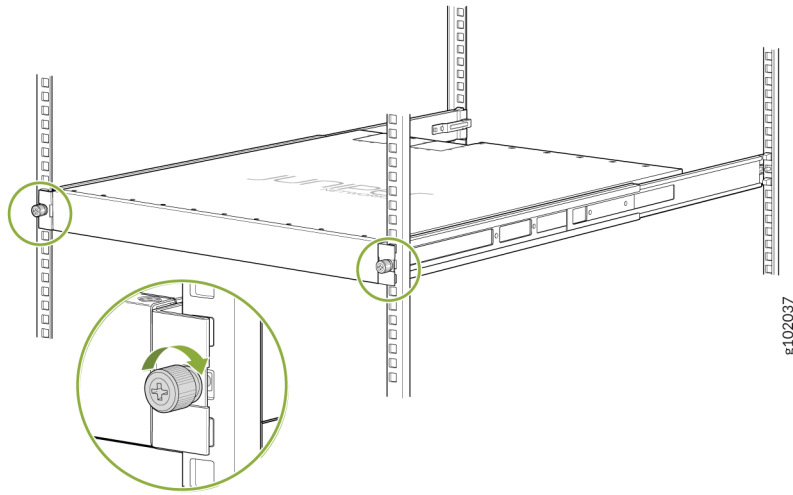

### **Mount the Device by Using the JNP-4PST-RMK-1U-E Rack Mount Kit On a Threaded Hole Rack**

Ensure that you have the following tools and parts available:

- An ESD grounding strap—not provided
- Number 2 Phillips (+) screwdriver—not provided
- A pair of front and rear mounting rails that attach to the rack posts—provided with the rack mount kit
- A pair of side mounting brackets and 16 flat head M4 x 6mm Phillips screws. These brackets attach to the device if not pre-installed—provided with the rack mount kit

To mount the device on four posts in a threaded hole rack by using the JNP-4PST-RMK-1U-E rack mount kit:

1. Wrap and fasten the ESD grounding strap to your bare wrist and connect the other end of the strap to the ESD point on the device.
2. Assemble the mounting rails.
  - a. Remove the guide blocks from the front mounting rails by loosening the screws and preserve them for later use. See Figure 10.

**Figure 42: Remove Guide Blocks from Front Mounting Rail**

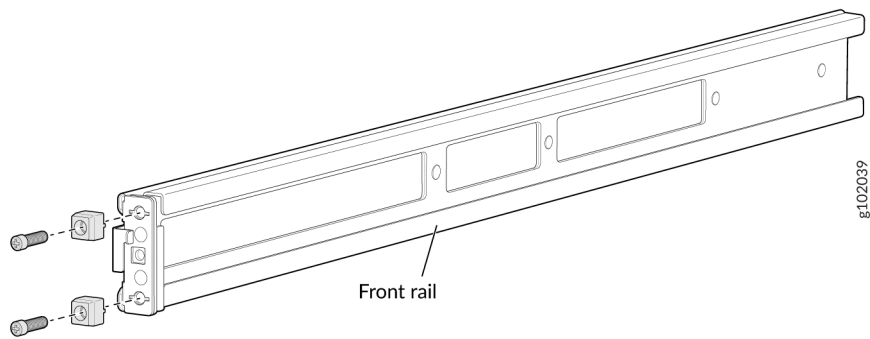

- b. Remove the guide blocks from the rear floating rails by loosening the screws and washers. Preserve the guide blocks, screws, and washers for later use. See Figure 11

**Figure 43: Remove Guide Blocks from Rear Floating Rail**

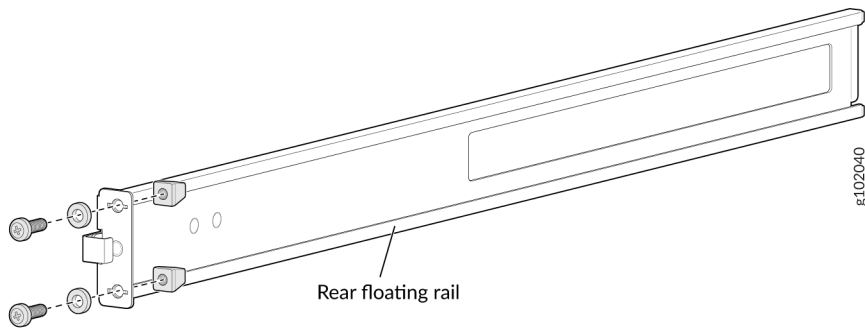

- c. Slide the rear floating rails into the front mounting rails. See Figure 12.

**Figure 44: Slide Rear Floating Rail into Front Mounting Rail**

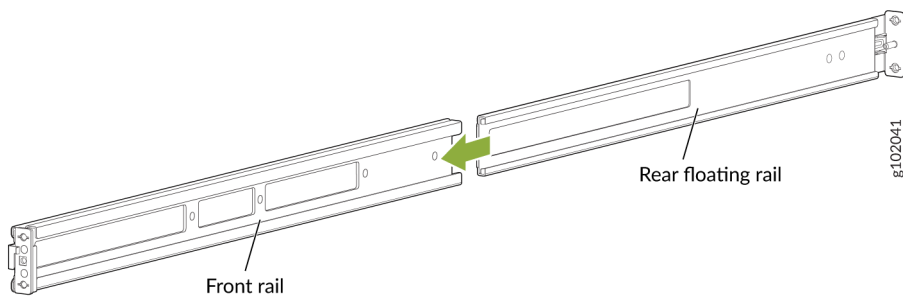

- d. Mounting rails assembled. See Figure 13.

**Figure 45: Front and Rear Rails Assembled**

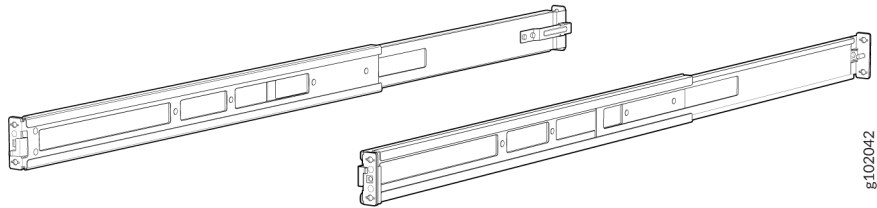

- 3. Attach the mounting rails to the threaded hole rack.**
- Align the guide blocks of the rear mounting rails with the rear-post holes. Pull the rear mounting rails toward the front of the rack to lock the rails in place. You will hear a click sound when the latch locks into the corresponding rack holes. See Figure 14.

**Figure 46: Install the Rear Floating Rails**

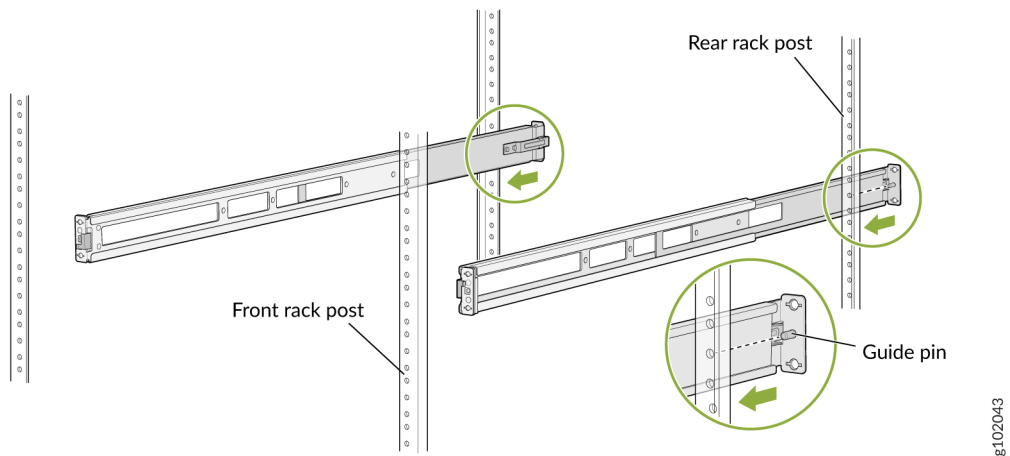

- Move the latch locks on the front mounting rails to open position, slide the front mounting rails and align them to the front rack post. Push the lock latch to locked position and using the screws removed in step 2.a and the washers removed in step 2.b, secure the front mounting rails to the front rack post. See Figure 15.

**Figure 47: Install the Front Mounting Rails**

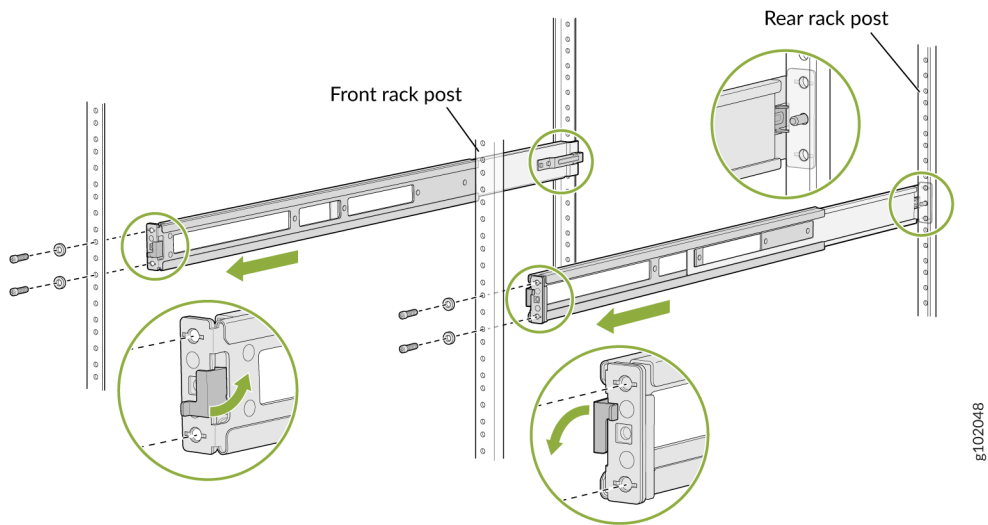

- c. Secure the rear floating rails to the rear rack post by using screws (not provided) appropriate for your rack threaded size. See Figure 16.

**Figure 48: Secure the Rear Floating Rails**

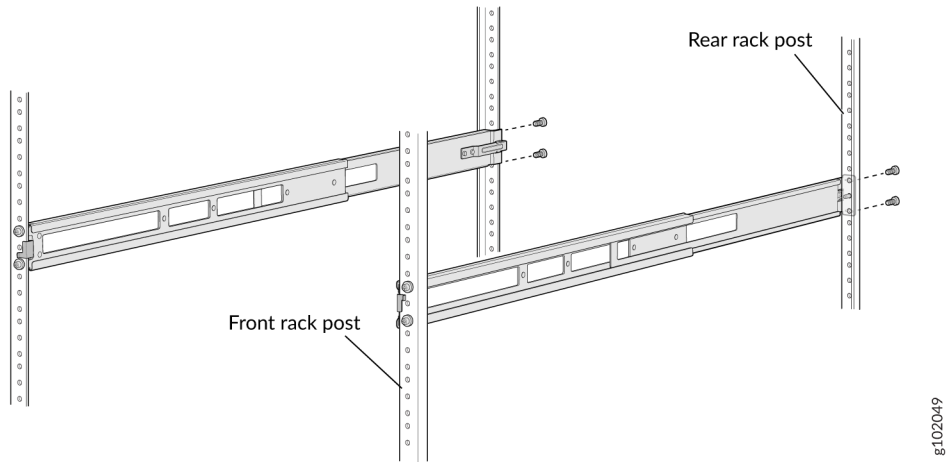

- d. Visually ensure that the front and rear latches are locked into place on the mounting rails. See Figure 17.

**Figure 49: Mounting Rails Installed and Secured**

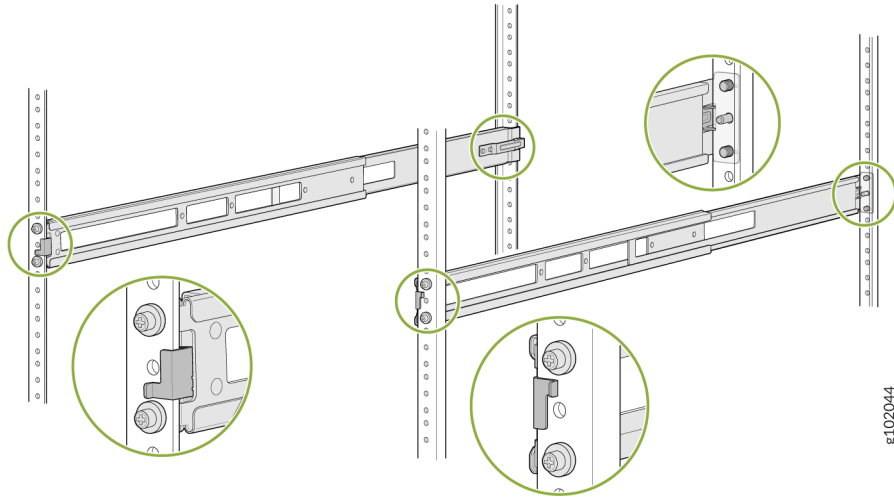

4. Attach mounting brackets to the device if not pre-installed. If your device already has the mounting brackets pre-installed than skip this step and move to the next step.
  - a. Align the holes on the mounting bracket with the screw holes on the side panel of the chassis.
  - b. Insert the flat head M4 x 6mm Phillips screws to attach the mounting bracket into the aligned holes on the chassis (see Figure 18). Tighten the screws.

**Figure 50: Attach the Mounting Brackets to the Device**

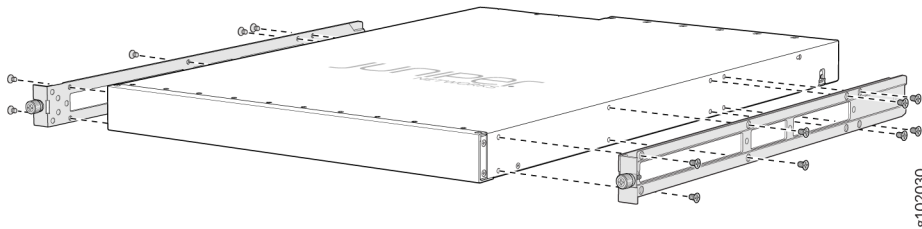

5. Position the device in such a manner that the **AIR OUT** labels on components are next to the hot aisle.
6. Grasp both sides of the device, lift it, and position the device such that the mounting rails slide into the channels of the mounting brackets. See Figure 19.

**Figure 51: Slide the Device into the Rack**

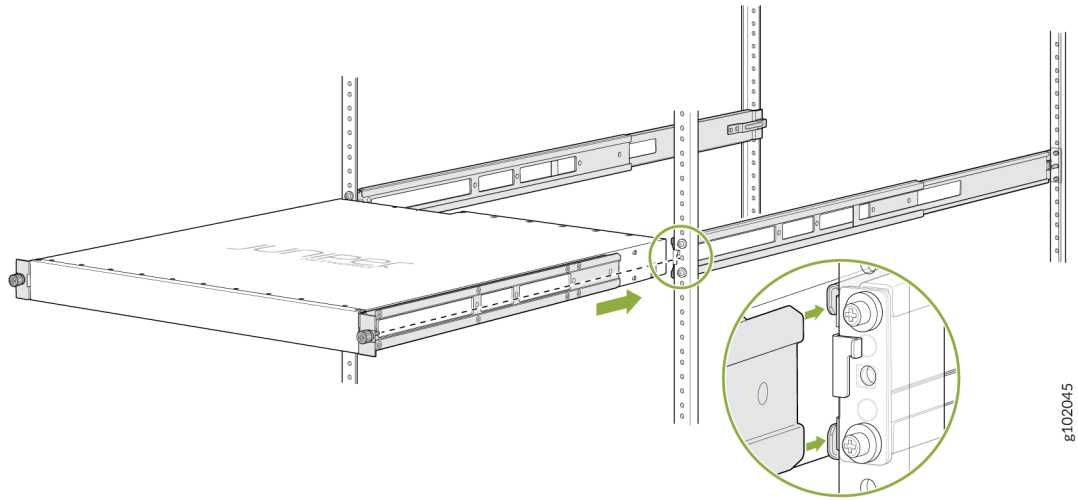

7. Tighten the two thumbscrews to secure the device. See Figure 20.

**Figure 52: Tighten Thumb Screws**

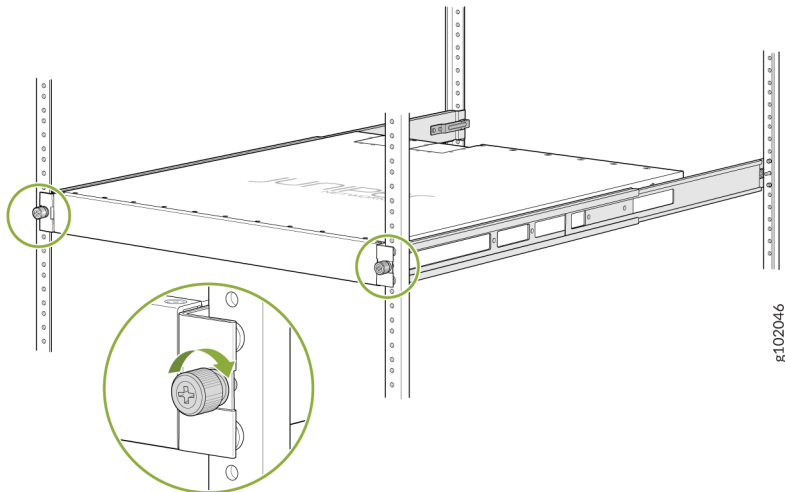

## RELATED DOCUMENTATION

[QFX5110 Installation Overview | 100](#)

[Rack-Mounting and Cabinet-Mounting Warnings | 186](#)

[Connecting the QFX5110 to External Devices | 118](#)

## Connecting the QFX5110 to External Devices

### IN THIS SECTION

- [Connect a Device to a Network for Out-of-Band Management | 118](#)
- [Connect a Device to a Management Console Using an RJ-45 Connector | 119](#)

### Connect a Device to a Network for Out-of-Band Management

Ensure that you have an Ethernet cable that has an RJ-45 connector at either end. [Figure 53 on page 118](#) shows the RJ-45 connector of the Ethernet cable.

**Figure 53: RJ-45 Connector on an Ethernet Cable**

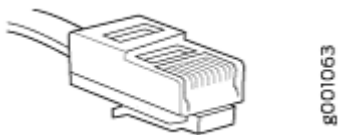

You can monitor and manage a network device, such as a router or a switch, by using a dedicated management channel. Each device has a management port to which you can connect an Ethernet cable with an RJ-45 connector. Use the management port to connect the device to the management device.

To connect a device to a network for out-of-band management (see [Figure 54 on page 119](#)):

1. Connect one end of the Ethernet cable to the management port on the device.
2. Connect the other end of the Ethernet cable to the management device.

**Figure 54: Connect a Device to a Network for Out-of-Band Management**

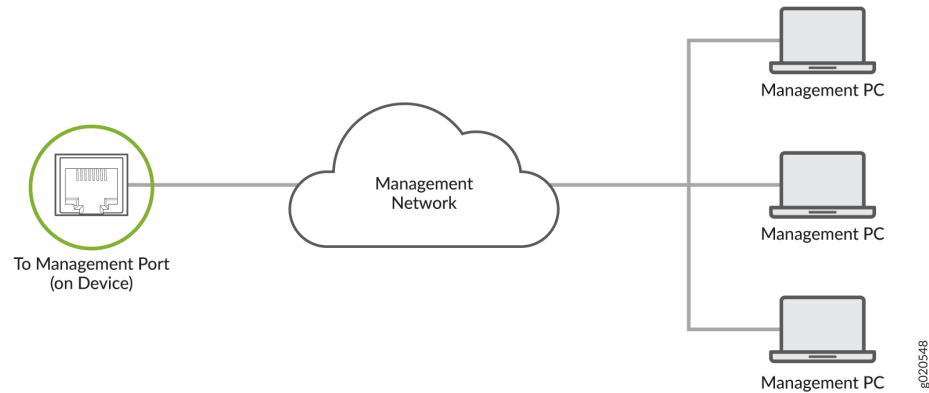

## Connect a Device to a Management Console Using an RJ-45 Connector

Ensure that you have an Ethernet cable that has an RJ-45 connector at either end and an RJ-45-to-DB-9 serial port adapter.

Figure 55 on page 119 shows the RJ-45 connector on the Ethernet cable.

**Figure 55: RJ-45 Connector on an Ethernet Cable**

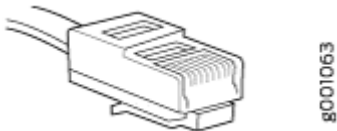

**NOTE:** We no longer include the RJ-45 console cable with the DB-9 adapter as part of the device package. If the console cable and adapter are not included in your device package, or if you need a different type of adapter, you can order the following separately:

- RJ-45 to DB-9 adapter (JNP-CBL-RJ45-DB9)
- RJ-45 to USB-A adapter (JNP-CBL-RJ45-USBA)
- RJ-45 to USB-C adapter (JNP-CBL-RJ45-USBC)



If you want to use RJ-45 to USB-A or RJ-45 to USB-C adapter you must have X64 (64-Bit) Virtual COM port (VCP) driver installed on your PC. See, <https://ftdichip.com/drivers/vcp-drivers/> to download the driver.

**NOTE:** If your laptop or desktop PC does not have a DB-9 plug connector pin and you want to connect your laptop or desktop PC directly to the device, use a combination of the RJ-45-to-DB-9 socket adapter and a USB-to-DB-9 plug adapter. You must provide the USB-to-DB-9 plug adapter.

You can configure and manage your network devices using a dedicated management channel. Each device has a console port that you can connect to using an Ethernet cable with an RJ-45 connector. Use the console port to connect the device to the console server or management console. The console port accepts a cable that has an RJ-45 connector.

To connect the device to a management console (see [Figure 56 on page 120](#) and [Figure 57 on page 120](#)):

1. Connect one end of the Ethernet cable to the console port (labeled **CON**, **CONSOLE**, or **CON1**) on the device.
2. Connect the other end of the Ethernet cable to the console server (see [Figure 56 on page 120](#)) or management console (see [Figure 57 on page 120](#)).

**Figure 56: Connect a Device to a Management Console Through a Console Server**

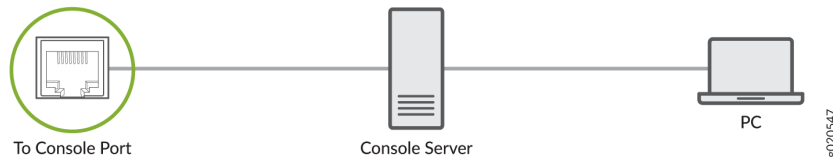

**Figure 57: Connect a Device Directly to a Management Console**



## RELATED DOCUMENTATION

[General Safety Guidelines and Warnings | 178](#)

[Grounded Equipment Warning | 190](#)

[Connecting the QFX5110 to Power | 121](#)

# Connecting the QFX5110 to Power

## IN THIS SECTION

- [Connect the QFX5110 to Earth Ground | 121](#)
- [Alternate Method to Ground QFX5110-48S-DC and QFX5110-32Q-DC Systems | 123](#)
- [Connecting AC Power to a QFX5110 | 124](#)
- [Connecting DC Power to a QFX5110 | 127](#)

## Connect the QFX5110 to Earth Ground

You must install the QFX5110 in a restricted-access location and ensure that the chassis is always properly grounded. The QFX5110 has a two-hole protective grounding terminal provided on the chassis. See [Figure 58 on page 122](#). Under all circumstances, use this grounding connection to ground the chassis. For AC-powered systems, you must also use the grounding wire in the AC power cord along with the two-hole grounding lug connection. This tested system meets or exceeds all applicable EMC regulatory requirements with the two-hole protective grounding terminal.



**CAUTION:** If an external ground connection is required, ensure that a licensed electrician has attached an appropriate grounding lug to the grounding cable that you supply. Using a grounding cable with an incorrectly attached lug can damage the switch (for example, by causing a short circuit).

**NOTE:** Mount your switch in the rack or cabinet before attaching the grounding lug to the switch. See "[Unpacking and Mounting the QFX5110](#)" on page 103.

Ensure that you have the following parts and tools available:

- Grounding cable for your QFX5110 device—The grounding cable must be 14 AWG (2 mm<sup>2</sup>), minimum 90° C wire, or as permitted by the local code (not provided).
- Grounding lug for your grounding cable—The grounding lug required is a Panduit LCD10-10A-L or equivalent (not provided).
- Two 10-32 x 0.25 screws with #10 split-lock washers—Two screws and washers are used to secure the grounding lug to the side of the chassis (not provided).
- Number 2 screwdriver.

An AC-powered QFX5110 switch chassis gains additional grounding when you plug the power supply in the switch into a grounded AC power outlet by using an AC power cord appropriate for your geographical location. See "[QFX5110 AC Power Cord Specifications](#)" on page 48.

To connect earth ground to a QFX5110:

1. Connect one end of the grounding cable to a proper earth ground, such as the rack in which the switch is mounted.
2. Place the grounding lug that is attached to the grounding cable over the protective earthing terminal.
3. Secure the grounding lug to the protective earthing terminal with two screws and washers. See [Figure 58 on page 122](#)

**Figure 58: Connecting a Grounding Cable to a QFX5110**

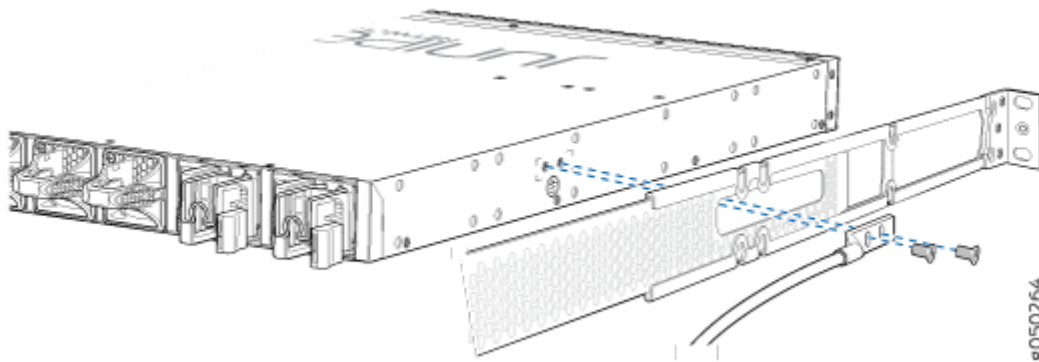

4. Dress the grounding cable and ensure that it does not touch or block access to other device components and that it does not drape where people could trip over it.

## Alternate Method to Ground QFX5110-48S-DC and QFX5110-32Q-DC Systems

Ensure that you have the following parts and tools available to ground the chassis using this method:

- M5 pan-head screw x .08 mm with integrated washer (not provided)
- M5 lug (not provided)
- 12 AWG (2.5 mm<sup>2</sup>) standard wire, 90° C wire or heavier (not provided)
- Number 2 screwdriver (not provided)

To connect earth ground to a QFX5110:DC power supply:

1. Have a licensed electrician attached the M5 grounding lug to the grounding cable that you supply.



**CAUTION:** Using a grounding cable with an incorrectly attached lug can damage the switch.

2. Ensure that all grounding surfaces are clean and brought to a bright finish before grounding connections are made.
3. Connect one end of the grounding cable to a proper earth ground, such as the rack in which the switch is mounted.
4. Place the grounding lug that is attached to the grounding cable over the protective earthing terminal on the DC power supply.
5. Use a screwdriver to secure the grounding lug to the protective earthing terminal with a M5 pan-head screw with integrated washer.
6. Dress the grounding cable and ensure that it does not touch or block access to other device components and that it does not drape where people could trip over it.

We recommend that you connect earth ground to a QFX5110 DC chassis using the "[Connect the QFX5110 to Earth Ground](#)" on page 121 method. However if you can't access the chassis using the two-holed grounding lug, you can ground the chassis using the DC protective earthing terminal on the DC power supply.

The DC power supplies have a protective earthing terminal on the face that holds an M5 pan-head screw with integrated washer. See [Figure 59 on page 124](#).

Figure 59: DC Power Supply Faceplate on a QFX5110

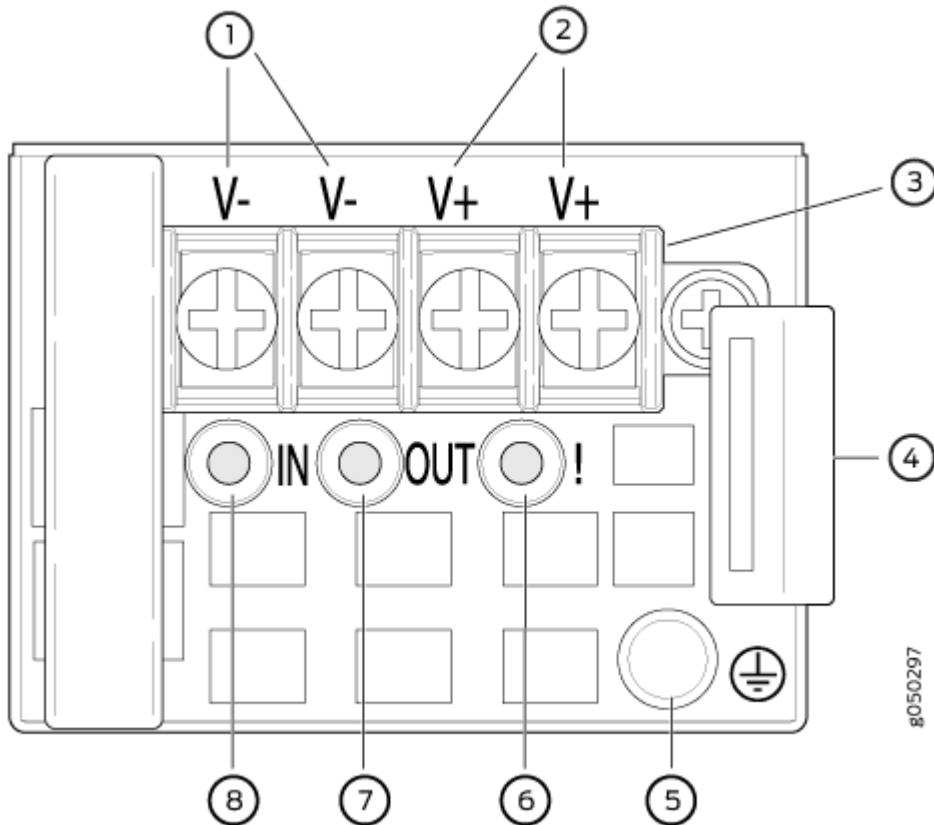

1– Shunt negative input terminals (-48V)	5– Protective earthing terminal
2– Shunt positive input terminals (+RTN)	6– Fault LED
3– Terminal block	7– Output LED
4– Security latch	8– Input LED

## Connecting AC Power to a QFX5110

Ensure that you have a power cord appropriate for your geographical location available to connect AC power to the switch.

Before you begin connecting AC power to the switch:

- Ensure that you have taken the necessary precautions to prevent electrostatic discharge (ESD) damage (see [Prevention of Electrostatic Discharge Damage](#)).
- Ensure that you have connected the switch chassis to earth ground.



**CAUTION:** Before you connect power to the switch, a licensed electrician must attach a cable lug to the grounding and power cables that you supply. A cable with an incorrectly attached lug can damage the switch (for example, by causing a short circuit).

To meet safety and electromagnetic interference (EMI) requirements and to ensure proper operation, you must connect the chassis to earth ground before you connect it to power. For installations that require a separate grounding conductor to the chassis, use the protective earthing terminal on the switch chassis to connect to the earth ground. For instructions on connecting earth ground, see "[Connect the QFX5110 to Earth Ground](#)" on page 121.

On AC systems, the switch gains additional grounding when you plug the power supply in the switch into a grounded AC power outlet by using the AC power cord appropriate for your geographical location (see "[QFX5110 AC Power Supply Description](#)" on page 45).



**CAUTION:**

- Install the power supply in the chassis. For instructions on installing a power supply in a QFX5110, see "[Installing a Power Supply in a QFX5110](#)" on page 146.

The QFX5110 is shipped with two 650 W power supplies pre-installed. Each power supply is a hot-removable and hot-insertable field-replaceable unit (FRU) when the second power supply is installed and running. You can install replacement power supplies in the two slots next to the fan modules without powering off the switch or disrupting switch functions.

**NOTE:** Each power supply must be connected to a dedicated power source outlet.

To connect AC power to a QFX5110:

1. Attach the grounding strap to your bare wrist and to a site ESD point.
2. Ensure that the power supplies are fully inserted in the chassis and the latches are secure. If only one power supply is installed, ensure that a blank cover panel is installed over the second power supply slot.
3. Locate the power cord or cords shipped with the switch; the cords have plugs appropriate for your geographical location. See "[QFX5110 AC Power Specifications](#)" on page 47.



**WARNING:** Ensure that the power cord does not block access to device components or drape where people can trip on it.

4. Connect each power supply to the power sources. Insert the coupler end of the power cord into the AC power cord inlet on the AC power supply faceplate.
5. Push the power cord retainer onto the power cord (see [Figure 60 on page 126](#)).

Figure 60: Connecting an AC Power Cord to an AC Power Supply in a QFX5110

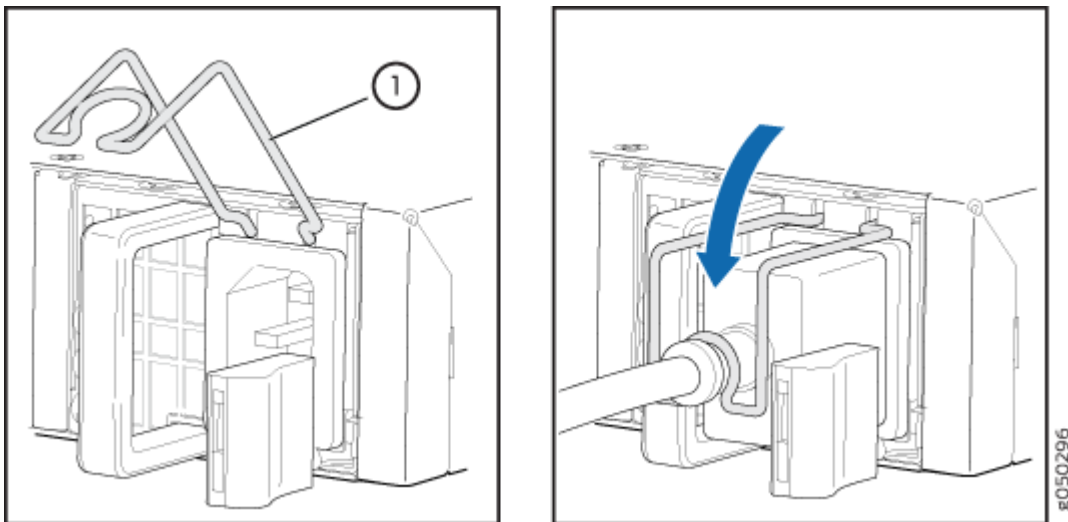

1– Power cord retainer

6. If the AC power source outlet has a power switch, set it to the off (O) position.

**NOTE:** The switch powers on as soon as power is provided to the power supply. There is no power switch on the device.

7. Insert the power cord plug into an AC power source outlet.
8. If the AC power source outlet has a power switch, set it to the on (I) position.
9. Verify that the AC and DC LEDs on each power supply are lit green.

If the amber fault LED is lit, remove power from the power supply, and replace the power supply (see ["Removing a Fan Module from a QFX5110" on page 141](#)). Do not remove the power supply until you have a replacement power supply ready: the power supplies or a blank cover panel must be installed in the switch to ensure proper airflow.



**CAUTION:** Replace a failed power supply with a blank panel or new power supply within one minute of removal to prevent chassis overheating.

## Connecting DC Power to a QFX5110

Before you begin connecting DC power to the switch:

- Ensure that you have taken the necessary precautions to prevent electrostatic discharge (ESD) damage (see [Prevention of Electrostatic Discharge Damage](#)).
- Ensure that you have connected the switch chassis to earth ground.



**CAUTION:** Before you connect power to the switch, a licensed electrician must attach a cable lug to the grounding and power cables that you supply. A cable with an incorrectly attached lug can damage the switch (for example, by causing a short circuit).

To meet safety and electromagnetic interference (EMI) requirements and to ensure proper operation, you must connect the chassis to earth ground before you connect it to power. For installations that require a separate grounding conductor to the chassis, use the protective earthing terminal on the switch chassis to connect to the earth ground. For instructions on connecting earth ground, see ["Connect the QFX5110 to Earth Ground"](#) on page 121.

On DC systems, you can also ground the chassis using the DC protective earthing terminal on the DC power supply as an alternate method. This method is useful if you are unable to access the chassis ground point by using the two-holed grounding lug, see ["Alternate Method to Ground QFX5110-48S-DC and QFX5110-32Q-DC Systems"](#) on page 123.

- Install the power supply in the chassis. For instructions on installing a power supply in a QFX5110, see ["Installing a Power Supply in a QFX5110"](#) on page 146.

Ensure that you have the following parts and tools available:

- DC power source cables (14–16 AWG) with ring lug (Molex 190700069 or equivalent) (not provided)
- Phillips (+) screwdriver, number 2 (not provided)
- Multimeter (not provided)



The QFX5110 is shipped from the factory with two 650 W power supplies. Each power supply is a hot-removable and hot-insertable field-replaceable unit (FRU) when the second power supply is installed and running. You can install replacement power supplies in the two slots next to the fan modules without powering off the switch or disrupting the switching function.



**WARNING:** A DC-powered QFX5110 is intended for installation only in a restricted access location.

**NOTE:** The battery returns of the DC power supply must be connected as an isolated DC return (DC-I).

To connect DC power to a QFX5110:

1. Attach the grounding strap to your bare wrist and to a site ESD point.
2. Verify that the DC power cables are correctly labeled before making connections to the power supply. In a typical power distribution scheme where the return is connected to chassis ground at the battery plant, you can use a multimeter to verify the resistance of the -48V and RTN DC cables to chassis ground:
  - The cable with very low resistance (indicating a closed circuit) to chassis ground is positive (+) and will be installed on the V+ (return) DC power input terminal.
  - The cable with very high resistance (indicating an open circuit) to chassis ground is negative (-) and will be installed on the V- (input) DC power input terminal.



**CAUTION:** You must ensure that power connections maintain the proper polarity. The power source cables might be labeled (+) and (-) to indicate their polarity. There is no standard color coding for DC power cables. The color coding used by the external DC power source at your site determines the color coding for the leads on the power cables that attach to the DC power input terminals on each power supply.

3. Install heat-shrink tubing insulation around the power cables.
 

To install heat-shrink tubing:

  - a. Slide the tubing over the portion of the cable where it is attached to the lug barrel. Ensure that tubing covers the end of the wire and the barrel of the lug attached to it.
  - b. Shrink the tubing with a heat gun. Ensure that you heat all sides of the tubing evenly so that it shrinks around the cable tightly.

Figure 61 on page 129 shows the steps to install heat-shrink tubing.

**NOTE:** Do not overheat the tubing.

**Figure 61: How to Install Heat-Shrink Tubing**

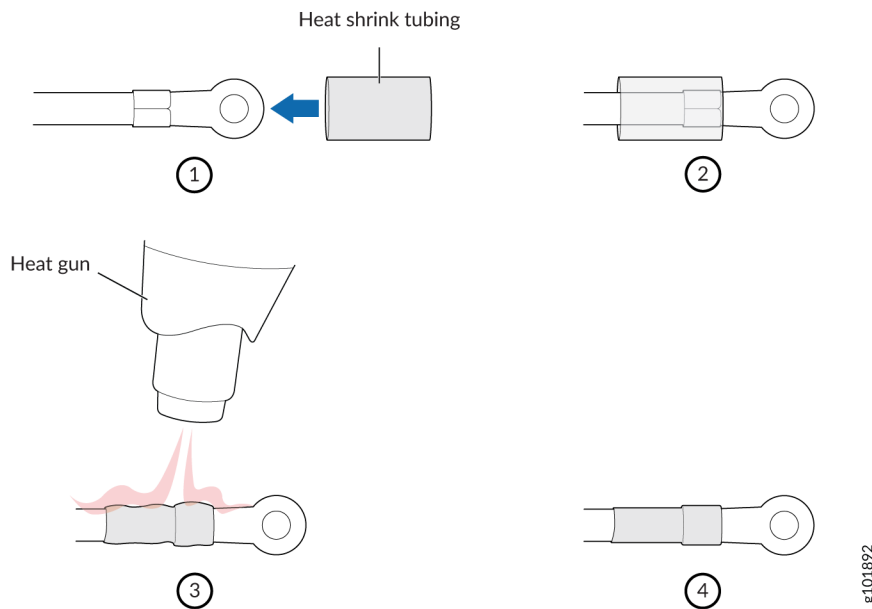

4. Ensure that the input circuit breaker is open so that the voltage across the DC power source cable leads is 0 V and that the cable leads do not become active while you are connecting DC power.

**NOTE:** The V+ terminals are referred to as +RTN, and V- terminals are referred to as -48 V in *DC Power Wiring Sequence Warning* and *DC Power Electrical Safety Guidelines*.

5. Ensure that the power supplies are fully inserted in the chassis.
6. Remove the terminal block cover. The terminal block cover is a piece of clear plastic that snaps into place over the terminal block (see [Figure 62 on page 131](#)).
7. Remove the screws on the terminals using the screwdriver. Save the screws.



**WARNING:** Ensure that the power cables do not block access to device components or drape where people can trip on them.

8. Connect each power supply to the power sources. Secure power source cables to the power supplies by screwing the ring lugs attached to the cables to the appropriate terminals by using the screw from the terminals (see [Figure 62 on page 131](#) and [Figure 63 on page 132](#)).

The QFX5110 is designed to operate with a DC power supply that has a single, non-redundant, feed input. For source redundancy, two DC power supplies must be installed in the QFX5110; connect source (A) to one power supply and connect source (B) to the second power supply. This configuration provides the commonly deployed A/B feed redundancy for the system.

The terminal block of the power supply has four terminals labeled V+, V+, V-, and V- for connecting DC power source cables labeled positive (+) and negative (-). The V+ terminals are shunted internally together, as are the V- terminals.



**CAUTION:** The connection between each power source and power supply must include a circuit breaker.

Do not connect two sources to a single power supply because doing so can potentially cause circulating current in feed wires whenever there is any difference in the voltage of the two sources.

- a. Secure the ring lug of the positive (+) DC power source cable to the V+ terminal on the DC power supply.
- b. Secure the ring lug of the negative (-) DC power source cable to the V- terminal on the DC power supply.
- c. Tighten the screws on the power supply terminals until snug using the screwdriver. Do not overtighten; apply between 5 in-lb (0.56 Nm) and 6 in-lb (0.68 Nm) of torque to the screws.

Figure 62: DC Power Supply Faceplate for a QFX5110

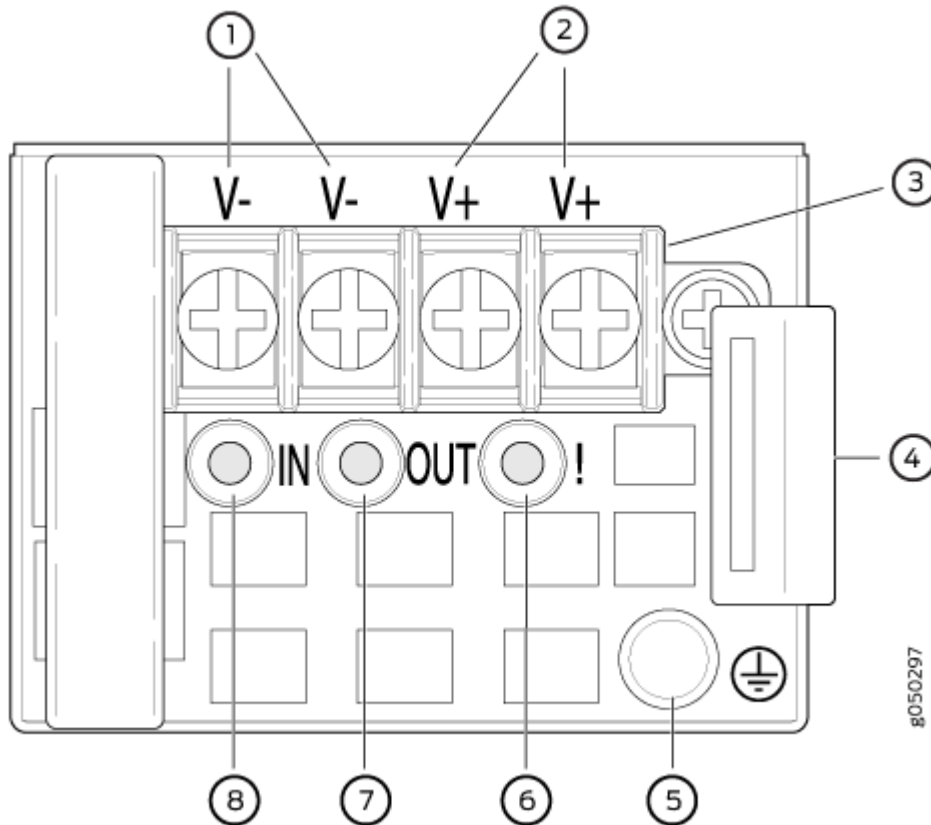

1– Shunt negative input terminals (+RTN)	5– Protective earthing terminal
2– Shunt positive input terminals (-48V)	6– Fault LED
3– Terminal block	7– Output LED
4– Ejector lever	8– Input LED



**CAUTION:** The V+ terminals are shunted internally together, as are the V- terminals. The same polarity terminal can be wired together from the same source to provide an additional current path in a higher power chassis. Do not connect the terminals to different sources.

Figure 63: Securing Ring Lugs to the Terminals on the QFX5110 DC Power Supply

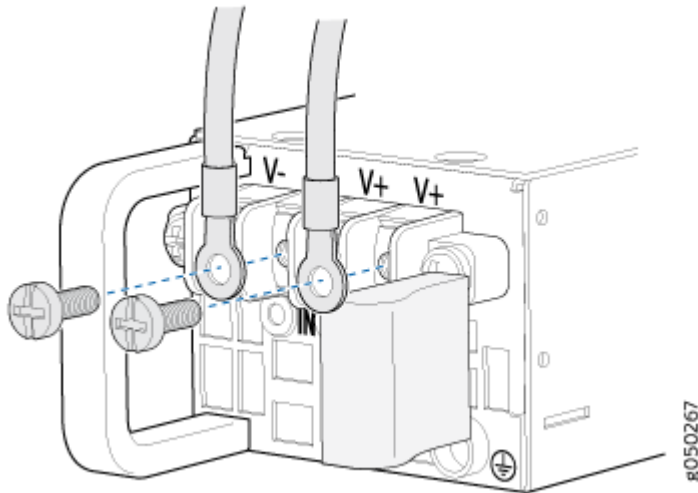

9. Replace the terminal block cover.
10. Close the input circuit breaker.

**NOTE:** The switch powers on as soon as power is provided to the power supply. There is no power switch on the device.

11. Verify that the **IN** and **OUT** LEDs on the power supply are lit green and are on steadily.

#### RELATED DOCUMENTATION

[QFX5110 Power System | 45](#)

[Maintaining QFX5110 Power Supplies | 144](#)

## Connecting the QFX5110 in a Virtual Chassis or Virtual Chassis Fabric

#### IN THIS SECTION

- [Connecting QFX5110 and QFX5100 Members in a QFX5110 Virtual Chassis | 133](#)

## Connecting QFX5110 and QFX5100 Members in a QFX5110 Virtual Chassis

QFX5110 Virtual Chassis are cabled in a ring topology. Each Virtual Chassis has a primary, a backup, and up to 8 additional switches participating as members of the Virtual Chassis. Select models of QFX5100 are allowed as line cards in a QFX5110 Virtual Chassis. For sample cabling diagrams, see [Figure 64 on page 133](#) and [Figure 65 on page 134](#). Supported configurations are described in "QFX5110 Hardware Overview" on page 12.

Figure 64: QFX5110 Virtual Chassis with all QFX5110 Members

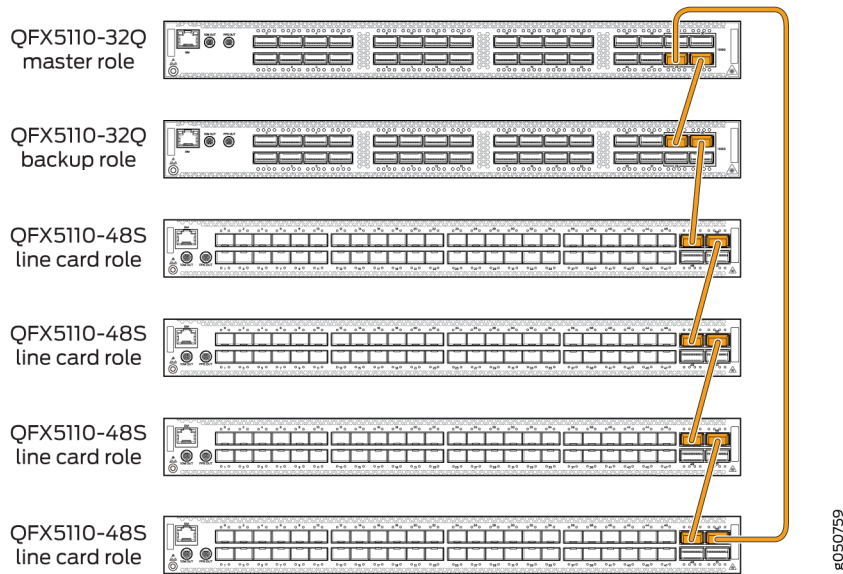

**Figure 65: QFX5110 Virtual Chassis with QFX5110 and QFX5100 Members**

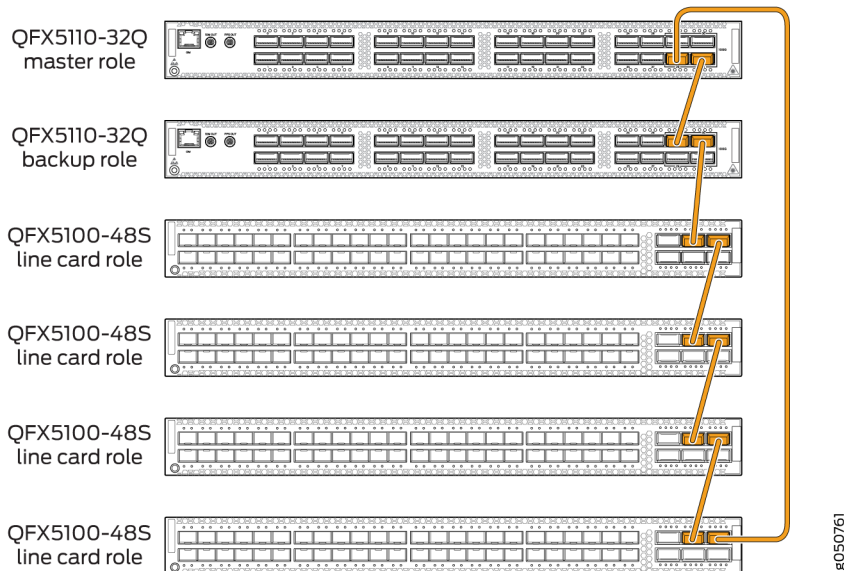

## SEE ALSO

*QFX5100 Device Hardware Overview*

## Connecting QFX5110 in a QFX5110 Virtual Chassis Fabric

A Juniper Networks QFX5110 Virtual Chassis Fabric (VCF) is constructed using a spine-and-leaf architecture and topology. In the spine-and-leaf architecture, each spine device is interconnected to each leaf device. QFX5110 VCFs support a maximum of 20 members in a VCF. Use QFX5110-32Q as either the spine or as a leaf device. Use QFX5110-48S, QFX5100-24Q, QFX5100-48S, QFX5100-48T, or QFX5100-96S models only as leaf devices.

[Figure 66 on page 135](#) shows cabling for a QFX5110 VCF with two QFX5110-32Q spine devices connected to four QFX5110-48S as leaf devices, all using all QSFP28 ports as VCPs. [Figure 67 on page 136](#) shows the cabling for a QFX5110 VCF using QFX5110-32Q as spines and QFX5100-24Q leaf devices.

Figure 66: All QFX5110 VCF

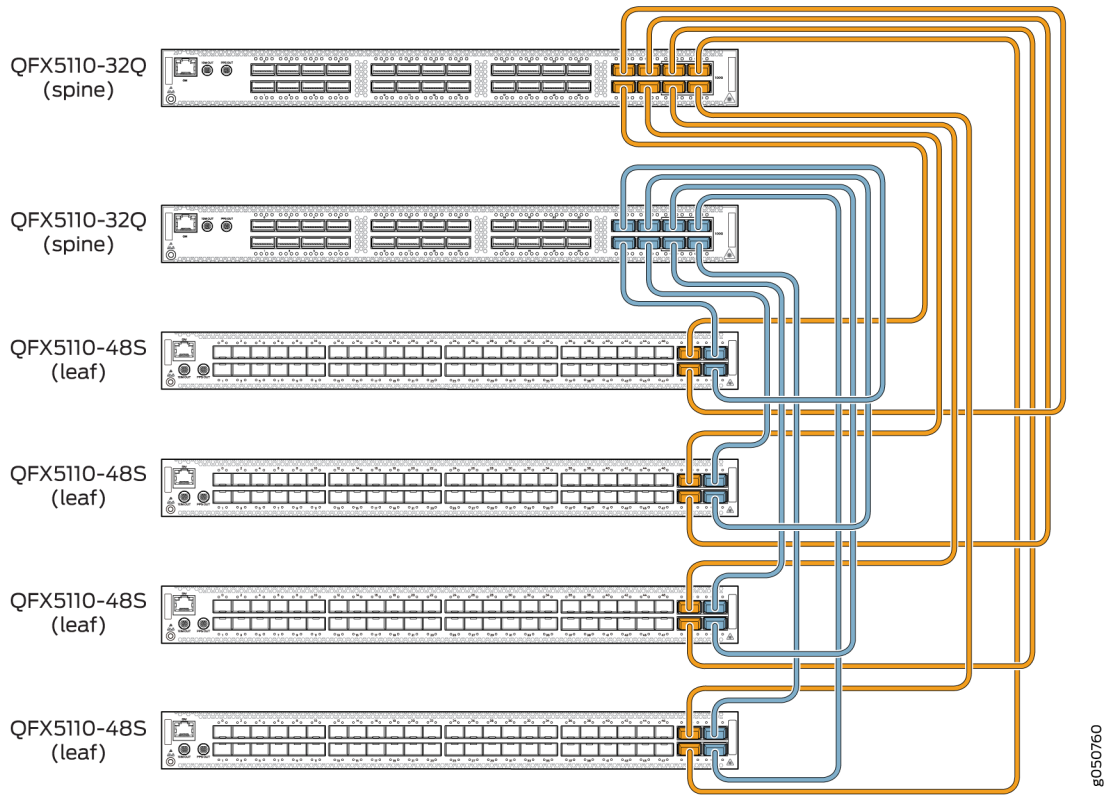
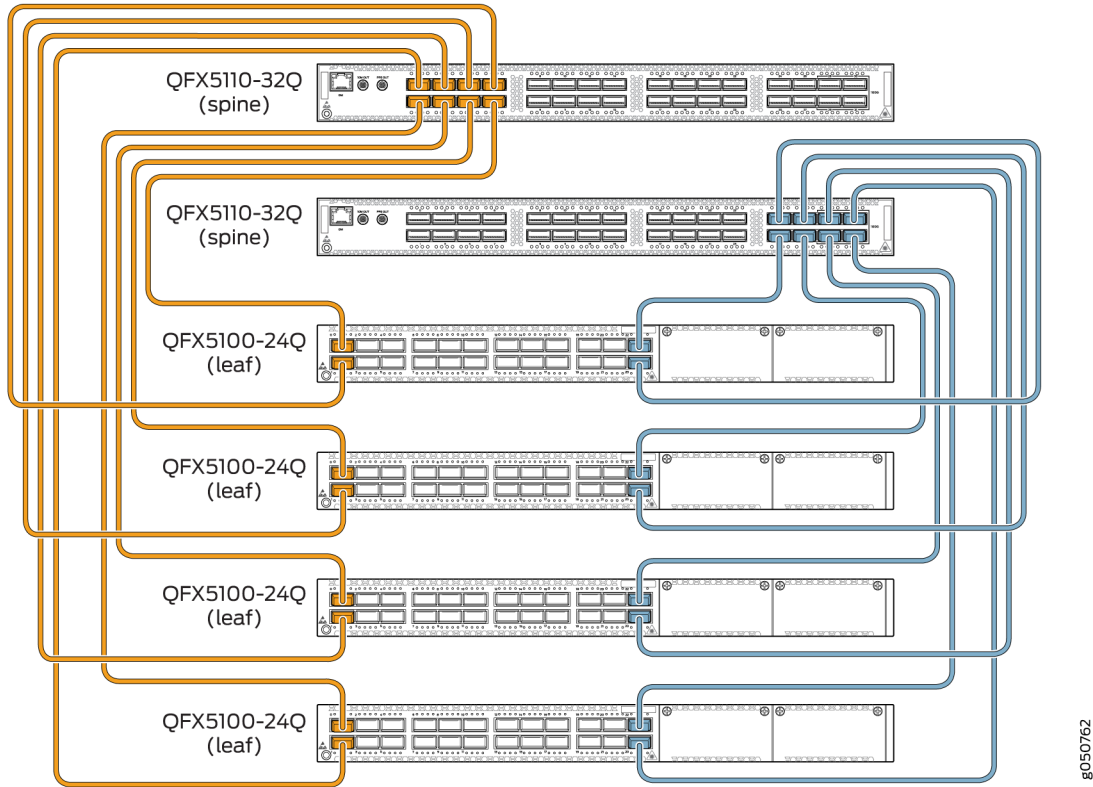



Figure 67: QFX5110 VCF with QFX5100-24Q Leaf Devices

**SEE ALSO**

[Virtual Chassis Fabric Hardware Overview | 75](#)

*Plan a Virtual Chassis Fabric Deployment*

## Configuring a QFX5110

Before you begin connecting and configuring a QFX5110, set the following parameter values on the console server or PC:

- Baud Rate—9600
- Flow Control—None
- Data—8

- Parity—None
- Stop Bits—1
- DCD State—Disregard

You must perform the initial configuration of the QFX5110 through the console port using the command-line interface (CLI).

**NOTE:** We no longer include the RJ-45 console cable with the DB-9 adapter as part of the device package. If the console cable and adapter are not included in your device package, or if you need a different type of adapter, you can order the following separately:

- RJ-45 to DB-9 adapter (JNP-CBL-RJ45-DB9)
- RJ-45 to USB-A adapter (JNP-CBL-RJ45-USBA)
- RJ-45 to USB-C adapter (JNP-CBL-RJ45-USBC)

If you want to use RJ-45 to USB-A or RJ-45 to USB-C adapter you must have X64 (64-Bit) Virtual COM port (VCP) driver installed on your PC. See, <https://ftdichip.com/drivers/vcp-drivers/> to download the driver.

To connect and configure the switch from the console:

1. Connect the console port to a laptop or PC using an RJ-45 cable and RJ-45 to DB-9 adapter. The console (**CON**) port is located on the management panel of the switch.
2. Log in as **root**. There is no password. If the software booted before you connected to the console port, you might need to press the Enter key for the prompt to appear.

```
login: root
```

3. Start the CLI.

```
root@% cli
```

4. Enter configuration mode.

```
root> configure
```

5. Add a password to the root administration user account.

```
[edit]
root@# set system root-authentication plain-text-password
New password: password
Retype new password: password
```

6. (Optional) Configure the name of the switch. If the name includes spaces, enclose the name in quotation marks (" ").

```
[edit]
root@# set system host-name host-name
```

7. Configure the default gateway.

```
[edit]
root@# set routing-options static route default next-hop address
```

8. Configure the IP address and prefix length for the switch management interface.

```
[edit]
root@# set interfaces em0 unit 0 family inet address address/prefix-length
```



**CAUTION:** Although the CLI permits you to configure two management Ethernet interfaces within the same subnet, only one interface is usable and supported.

**NOTE:** The management ports em0 (C0) and em1 (C1) are found on the FRU end of the QFX5110 switch.

9. (Optional) Configure the static routes to remote prefixes with access to the management port.

```
[edit]
root@# set routing-options static route remote-prefix next-hop destination-ip retain no-
readvertise
```

10. Enable Telnet service.

```
[edit]  
root@# set system services telnet
```

**NOTE:** When Telnet is enabled, you cannot log in to a QFX5110 switch through Telnet using root credentials. Root login is allowed only for SSH access.

11. Enable SSH service for root login.

```
[edit]  
root@# set system services SSH
```

12. Commit the configuration to activate it on the switch.

```
[edit]  
root@# commit
```

## RELATED DOCUMENTATION

| [Standalone Installation Overview](#) | 100

# 5

CHAPTER

## Maintaining Components

---

Maintaining QFX5110 Fan Modules | 141

Maintaining QFX5110 Power Supplies | 144

Removing and Installing Transceivers and Fiber-Optic Cables on QFX5110 | 148

Powering Off a QFX5110 | 157

Removing a QFX5110 from a Rack | 159

---

# Maintaining QFX5110 Fan Modules

## IN THIS SECTION

- [Removing a Fan Module from a QFX5110 | 141](#)
- [Installing a Fan Module in a QFX5110 | 142](#)

## Removing a Fan Module from a QFX5110

Before you remove a fan module from a QFX5110, ensure that you have taken the necessary precautions to prevent electrostatic discharge (ESD) damage (see [Prevention of Electrostatic Discharge Damage](#)).

Ensure that you have the following parts and tools available to remove a fan module from a QFX5110:

- ESD grounding strap
- Antistatic bag or an antistatic mat

The fan modules in the QFX5110 are hot-removable and hot-insertable field-replaceable units (FRUs): you can remove and replace them without powering off the switch or disrupting switch functions.



**CAUTION:** Replace a failed fan module with a new fan module within 1 minute of removal to prevent chassis overheating. Before removing the fan module, ensure you have a replacement fan module at hand.

To remove a fan module from a QFX5110 (see [Figure 68 on page 142](#)):

1. Place the antistatic bag or the antistatic mat on a flat, stable surface.
2. Attach the ESD grounding strap to your bare wrist, and connect the strap to the ESD point on the chassis.
3. Using a Phillips screwdriver, loosen the locking screw (three or four turns).
4. Grasp the handle on the fan module and squeeze the outside of the handle to release the module.



**WARNING:** To avoid injury, do not touch the fan with your hands or any tools as you slide the fan module out of the chassis—the fan might still be running.

5. Pull firmly to slide the fan module halfway out of the chassis.
6. When the fan stops spinning, slide the fan module completely out of the chassis.
7. Place the fan module in the antistatic bag or on the antistatic mat placed on a flat, stable surface.

Figure 68: Removing a Fan Module from a QFX5110

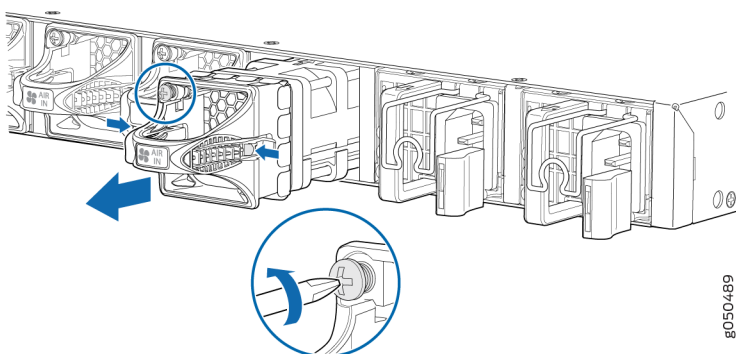

**NOTE:** When a fan module is removed, the CLI message “**Fan/Blower is Absent**” is logged in the system log, and the system raises a minor alarm.

## Installing a Fan Module in a QFX5110

Before you install a fan module in a QFX5110, ensure that you have taken the necessary precautions to prevent electrostatic discharge (ESD) damage (see [Prevention of Electrostatic Discharge Damage](#)).

The fan modules in a QFX5110 are hot-removable and hot-insertable field-replaceable units (FRUs): you can remove and replace them without powering off the switch or disrupting switch functions.



**CAUTION:** Replace a failed fan module with a new fan module within 1 minute of removal to prevent chassis overheating. Before removing the fan module, ensure you have a replacement fan module at hand.

**NOTE:** The fan module provides FRU-to-port or port-to-FRU airflow, depending on the switch product SKU you purchase. In legacy switches, or switches with an LCD, this airflow is called front to back and back to front.

To install a fan module in a QFX5110 (see [Figure 69 on page 143](#)):

1. Attach the ESD grounding strap to your bare wrist, and connect the strap to the ESD point on the chassis.
2. Taking care not to touch the connectors, remove the fan module from its bag.
3. Align the module with the open slot on the management panel of the chassis and slide it in until it is fully seated.

**Figure 69: Installing a Fan Module in a QFX5110**

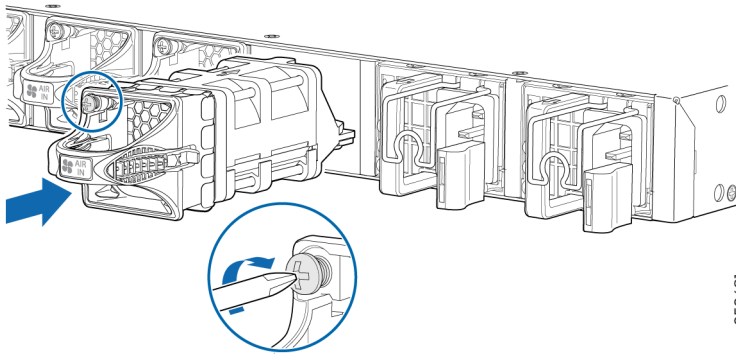

**CAUTION:** Damage can occur if you attempt to install a fan module into a chassis with a different airflow direction. Compare the switch product SKU with the airflow marking on the handle to ensure that you are installing a fan module with the same airflow direction as the chassis. The fan modules are designed so that they can only be inserted into the QFX5110 product SKU that supports the same airflow type. See "[QFX5110 Cooling System and Airflow Description](#)" on page 38 for more information.

4. Using a Phillips screwdriver, turn the locking screw until it is tight.

## RELATED DOCUMENTATION

[QFX5110 Cooling System and Airflow Description](#) | 38



## Maintaining QFX5110 Power Supplies

### IN THIS SECTION

- [Removing a Power Supply from a QFX5110 | 144](#)
- [Installing a Power Supply in a QFX5110 | 146](#)

### Removing a Power Supply from a QFX5110

Before you remove a power supply from a QFX5110, ensure that you have taken the necessary precautions to prevent electrostatic discharge (ESD) damage (see [Prevention of Electrostatic Discharge Damage](#)).

Ensure that you have the following parts and tools available to remove a power supply from a QFX5110:

- ESD grounding strap
- Antistatic bag or an antistatic mat
- Phillips (+) screwdriver, number 2 (DC power supply)

All QFX5110 switches, except the QFX5110-32Q-CHAS are shipped from the factory with two power supplies. Each power supply is a hot-removable and hot-insertable field-replaceable unit (FRU) when the second power supply is installed and running. You can install replacement power supplies in the two slots next to the fan modules without powering off the switch or disrupting the switching function.



**CAUTION:** Replace the power supply with a new power supply within 1 minute of removal to prevent chassis overheating.

To remove a power supply from a QFX5110 (see [Figure 70 on page 145](#)):

1. Place the antistatic bag or the antistatic mat on a flat, stable surface.

2. Attach the ESD grounding strap to your bare wrist, and connect the strap to the ESD point on the chassis.

**NOTE:** If only one power supply is installed in your QFX5110, you need to power off the switch before removing the power supply. See "[Powering Off a QFX5110](#)" on page 157.

3. Disconnect power to the switch:
  - AC power supply—If the AC power source outlet has a power switch, set it to the off (O) position. If the AC power source outlet does not have a power switch, gently pull out the plug end of the power cord connected to the power source outlet.
  - DC power supply—Switch the circuit breaker on the panel board that services the DC circuit to the off position.
4. Remove the power source cable from the power supply faceplate:
  - AC power supply—Remove the power cord from the power supply faceplate by detaching the power cord retainer and gently pulling out the socket end of the power cord connected to the power supply faceplate.
  - DC power supply—Remove the screws securing the ring lugs attached to the power source cables to the power supply using the screwdriver, and remove the power source cables from the power supply. Replace the screws on the terminals and tighten them.
5. Slide the locking lever toward the handle until it stops.
6. Grasp the power supply handle and pull firmly to slide the power supply halfway out of the chassis.
7. Place one hand under the power supply to support it and slide it completely out of the chassis. Take care not to touch power supply components, pins, leads, or solder connections.
8. Place the power supply in the antistatic bag or on the antistatic mat placed on a flat, stable surface.

**Figure 70: Removing a Power Supply from a QFX5110**

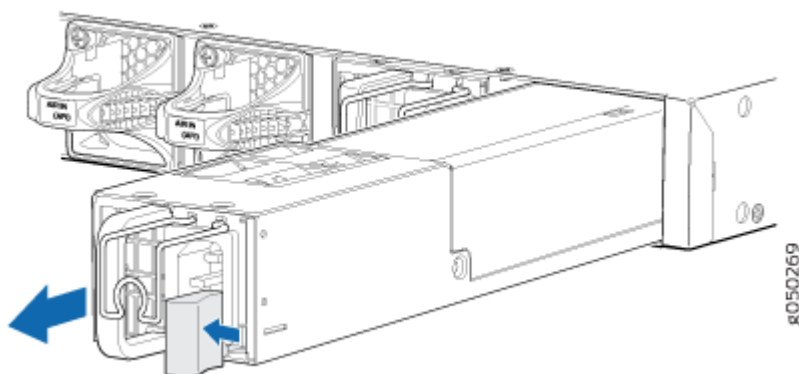

## Installing a Power Supply in a QFX5110

- Before you install a power supply in a QFX5110, ensure that you have taken the necessary precautions to prevent electrostatic discharge (ESD) damage (see [Prevention of Electrostatic Discharge Damage](#)).
- Ensure that the airflow direction of the power supply is the same as the chassis. Labels on the power supply handle indicate the direction of airflow. See "[QFX5110 Cooling System and Airflow Description](#)" on page 38 for more information.

All QFX5110 switches, except the QFX5110-32Q-CHAS are shipped from the factory with two power supplies. Each power supply is a hot-removable and hot-insertable field-replaceable unit (FRU) when the second power supply is installed and running. You can install replacement power supplies in the two slots next to the fan modules without powering off the switch or disrupting the switching function.

To install a power supply in a QFX5110 (see [Figure 72 on page 147](#)):

1. Attach the ESD grounding strap to your bare wrist, and connect the strap to the ESD point on the chassis.
2. Taking care not to touch power supply components, pins, leads, or solder connections, remove the power supply from its bag.



**CAUTION:** Verify that the direction of the arrow on the power supply handle matches the direction of airflow in the chassis. Ensure that each power supply you install in the chassis has the same airflow direction. If you install power supplies with two different airflow directions, Junos OS raises an alarm, and the status (ALM) LED blinks amber.

3. Using both hands, lift the power supply and place it over the EMI gasket (if present) in the power supply slot and slide the power supply into place.

Figure 71: Installing a Power Supply in a QFX5110-32Q with EMI Gasket

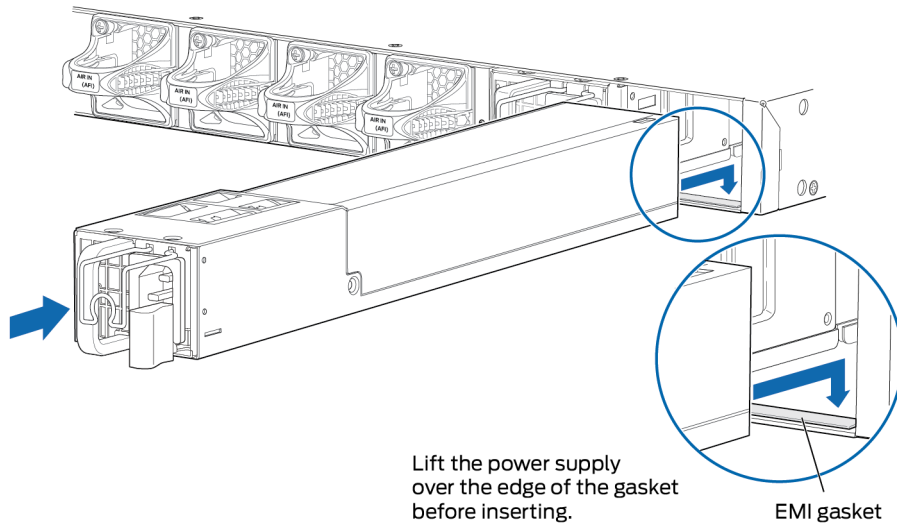

**NOTE:** The EMI gasket is not present in QFX5110-48S switch.

4. Ensure the power supply is fully seated and the locking lever is in place.

Figure 72: Installing a Power Supply in a QFX5110-48S

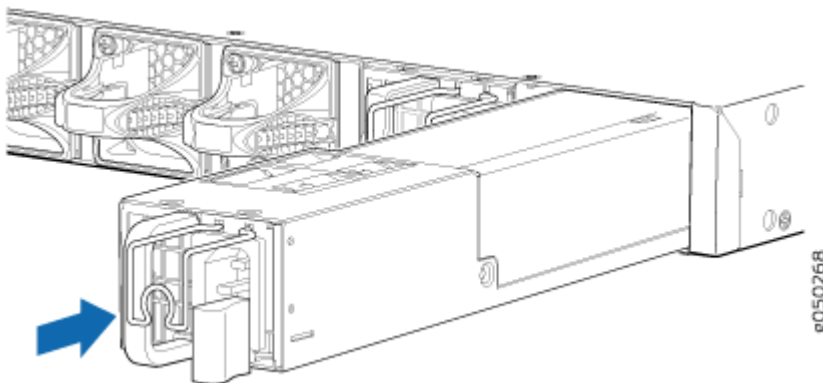

**NOTE:** Each power supply must be connected to a dedicated power source outlet.

**NOTE:** If you have a Juniper Care service contract, register any addition, change, or upgrade of hardware components at <https://www.juniper.net/customers/support/tools/updateinstallbase/>. Failure to do so can result in significant delays if you need replacement parts. This note does not apply if you replace existing components with the same type of component.

## RELATED DOCUMENTATION

[QFX5110 Power System | 45](#)

[Connecting the QFX5110 to Power | 121](#)

[QFX5110 Field-Replaceable Units | 19](#)

# Removing and Installing Transceivers and Fiber-Optic Cables on QFX5110

## IN THIS SECTION

- [Remove a Transceiver | 148](#)
- [Install a Transceiver | 151](#)
- [Disconnect a Fiber-Optic Cable | 154](#)
- [Connect a Fiber-Optic Cable | 155](#)
- [How to Handle Fiber-Optic Cables | 156](#)

## Remove a Transceiver

Before you remove a transceiver from a device, ensure that you have taken the necessary precautions for the safe handling of lasers (see [Laser and LED Safety Guidelines and Warnings](#)).

Ensure that you have the following parts and tools available:

- An antistatic bag or an antistatic mat

- Rubber safety caps to cover the transceiver and fiber-optic cable connector
- A dust cover to cover the port or a replacement transceiver

The transceivers for Juniper Networks devices are hot-removable and hot-insertable field-replaceable units (FRUs). You can remove and replace the transceivers without powering off the device or disrupting device functions.

**NOTE:** After you remove a transceiver, or when you change the media-type configuration, wait for 6 seconds for the interface to display the operational commands.

Figure 73 on page 150 shows how to remove a quad small form-factor pluggable plus (QSFP+) transceiver. The procedure is the same for all types of transceivers except the QSFP28 and C form-factor pluggable (CFP) transceivers.

To remove a transceiver from a device:

1. Place the antistatic bag or antistatic mat on a flat, stable surface.
2. Wrap and fasten one end of the ESD wrist strap around your bare wrist, and connect the other end of the strap to the ESD point on the rack.
3. Label the cable connected to the transceiver so that you can reconnect it correctly.



**LASER WARNING:** Do not look directly into a fiber-optic transceiver or into the ends of fiber-optic cables. Fiber-optic transceivers and fiber-optic cables connected to transceivers emit laser light that can damage your eyes.



**LASER WARNING:** Do not leave a fiber-optic transceiver uncovered except when inserting or removing a cable. The rubber safety cap keeps the port clean and protects your eyes from accidental exposure to laser light.



**CAUTION:** Do not bend fiber-optic cables beyond their minimum bend radius. An arc smaller than a few inches in diameter can damage the cables and cause problems that are difficult to diagnose.

4. Remove the cable connected to the transceiver (see [Disconnect a Fiber-Optic Cable](#)). Cover the transceiver and the end of each fiber-optic cable connector with a rubber safety cap immediately after disconnecting the fiber-optic cables.

5. If there is a cable management system, arrange the cable in the cable management system to prevent it from dislodging or developing stress points. Secure the cable so that it does not support its own weight as it hangs to the floor. Place excess cable out of the way in a neatly coiled loop in the cable management system. Placing fasteners on the loop helps to maintain its shape.
6. To remove an SFP56-DD, SFP, SFP+, XFP, a QSFP+, or QSFP56-DD transceiver:
  - a. Using your fingers, pull open the ejector lever on the transceiver to unlock the transceiver.  
Note that QSFP-DD and SFP-DD transceivers don't have ejector levers, instead they have a pull tab which can be used to unlock and remove the transceiver.



**CAUTION:** Before removing the transceiver, make sure that you open the ejector lever completely until you hear it click. This precaution prevents damage to the transceiver.

- b. Grasp the transceiver ejector lever and gently slide the transceiver approximately 0.5 in. (1.3 cm) straight out of the port.



**CAUTION:** To prevent ESD damage to the transceiver, do not touch the connector pins at the end of the transceiver.

**Figure 73: Remove a QSFP+ Transceiver**

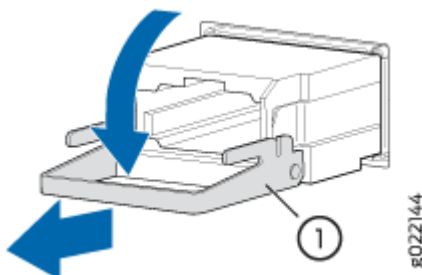

1– Ejector lever

To remove a CFP transceiver:

- a. Using your fingers, loosen the screws on the transceiver.
- b. Grasp the screws on the transceiver and gently slide the transceiver approximately 0.5 in. (1.3 cm) straight out of the port.



**CAUTION:** To prevent ESD damage to the transceiver, do not touch the connector pins at the end of the transceiver.

7. Using your fingers, grasp the body of the transceiver and pull it straight out of the port.
8. Place the transceiver in the antistatic bag or on the antistatic mat placed on a flat, stable surface.
9. Place the dust cover over the empty port, or install the replacement transceiver.

## Install a Transceiver

Before you install a transceiver in a device, ensure that you have taken the necessary precautions for safe handling of lasers (see [Laser and LED Safety Guidelines and Warnings](#)).

Ensure that you have a rubber safety cap available to cover the transceiver.

The transceivers for Juniper Networks devices are hot-removable and hot-insertable field-replaceable units (FRUs). You can remove and replace the transceivers without powering off the device or disrupting the device functions.

**NOTE:** After you insert a transceiver or after you change the media-type configuration, wait for 6 seconds for the interface to display operational commands.

**NOTE:** We recommend that you use only optical transceivers and optical connectors purchased from Juniper Networks with your Juniper Networks device.



**CAUTION:** The Juniper Networks Technical Assistance Center (JTAC) provides complete support for Juniper-supplied optical modules and cables. However, JTAC does not provide support for third-party optical modules and cables that are not qualified or supplied by Juniper Networks. If you face a problem running a Juniper device that uses third-party optical modules or cables, JTAC may help you diagnose host-related issues if the observed issue is not, in the opinion of JTAC, related to the use of the third-party optical modules or cables. Your JTAC engineer will likely request that you check the third-party optical module or cable and, if required, replace it with an equivalent Juniper-qualified component.



Use of third-party optical modules with high-power consumption (for example, coherent ZR or ZR+) can potentially cause thermal damage to or reduce the lifespan of the host equipment. Any damage to the host equipment due to the use of third-party optical modules or cables is the users' responsibility. Juniper Networks will accept no liability for any damage caused due to such use.

Figure 74 on page 154 shows how to install a QSFP+ transceiver. The procedure is the same for all types of transceivers except the QSFP28 and CFP transceivers.

To install a transceiver:



**CAUTION:** To prevent electrostatic discharge (ESD) damage to the transceiver, do not touch the connector pins at the end of the transceiver.

1. Wrap and fasten one end of the ESD wrist strap around your bare wrist, and connect the other end of the strap to a site ESD point or to the ESD point on the device.
2. Remove the transceiver from its bag.
3. Check to see whether the transceiver is covered with a rubber safety cap. If it is not, cover the transceiver with a rubber safety cap.



**LASER WARNING:** Do not leave a fiber-optic transceiver uncovered except when inserting or removing a cable. The rubber safety cap keeps the port clean and protects your eyes from accidental exposure to laser light.

4. If the port in which you want to install the transceiver is covered with a dust cover, remove the dust cover and save it in case you need to cover the port later. If you are hot-swapping a transceiver, wait for at least 10 seconds after removing the transceiver from the port before installing a new transceiver.
5. Using both hands, carefully place the transceiver in the empty port. The connectors must face the chassis.



**CAUTION:** Before you slide the transceiver into the port, ensure that the transceiver is aligned correctly. Misalignment might cause the pins to bend, making the transceiver unusable.

6. Slide the transceiver in gently until it is fully seated. If you are installing a CFP transceiver, use your fingers to tighten the captive screws on the transceiver.
7. Remove the rubber safety cap from the transceiver and the end of the cable, and insert the cable into the transceiver.



**LASER WARNING:** Do not look directly into a fiber-optic transceiver or into the ends of fiber-optic cables. Fiber-optic transceivers and fiber-optic cable connected to a transceiver emit laser light that can damage your eyes.



**CAUTION:** Do not leave a fiber-optic transceiver uncovered except when inserting or removing cable. The safety cap keeps the port clean and protects your eyes from accidental exposure to laser light.

8. If there is a cable management system, arrange the cable in the cable management system to prevent the cable from dislodging or developing stress points. Secure the cable so that it does not support its own weight as it hangs toward the floor. Place excess cable out of the way in a neatly coiled loop in the cable management system. Placing fasteners on the loop helps to maintain its shape.



**CAUTION:** Do not let fiber-optic cable hang free from the connector. Do not allow fastened loops of cable to dangle, which stresses the cable at the fastening point.



**CAUTION:** Avoid bending fiber-optic cable beyond its minimum bend radius. An arc smaller than a few inches in diameter can damage the cable and cause problems that are difficult to diagnose.

**NOTE:** When you install SFP-DD transceivers, push it hard until you hear a click sound. Use a long nose plier to pull the SFP-DD transceiver connected on the top and bottom rows of the chassis where the pull tabs face each other.

**NOTE:** Make sure to use a dust cap to cover ports that are unused.

**NOTE:** While using Finisar AOC SFP+ optical module with the QFX5130-48C switch, you may need to pull the module upwards to pull out the module smoothly from the cage.

Figure 74: Install a Transceiver

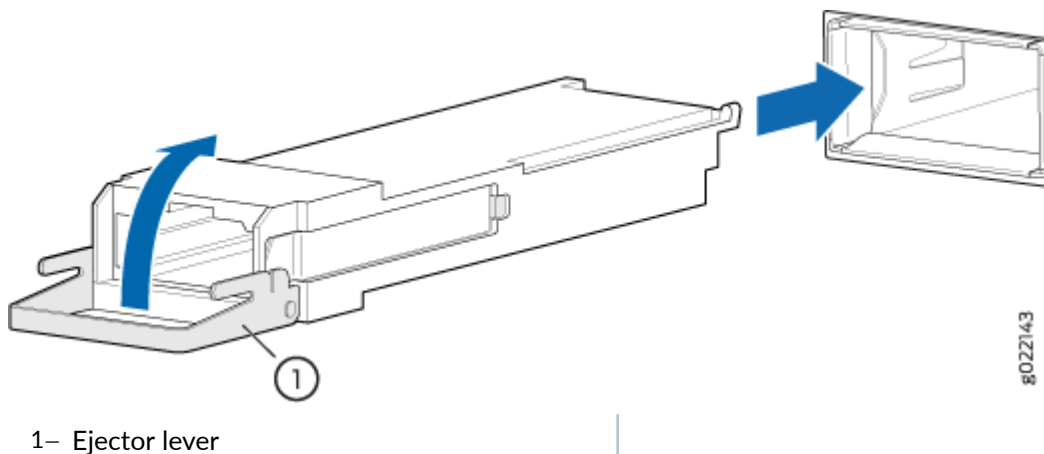

## Disconnect a Fiber-Optic Cable

Before you disconnect a fiber-optic cable from an optical transceiver, ensure that you have taken the necessary precautions for safe handling of lasers. See [Laser and LED Safety Guidelines and Warnings](#).

Ensure that you have the following parts and tools available:

- A rubber safety cap to cover the transceiver
- A rubber safety cap to cover the fiber-optic cable connector

Juniper Networks devices have optical transceivers to which you can connect fiber-optic cables.

To disconnect a fiber-optic cable from an optical transceiver installed in the device:

1. Disable the port in which the transceiver is installed by issuing the following command:

```
[edit interfaces]
user@device# set interface-name disable
```



**LASER WARNING:** Do not look directly into a fiber-optic transceiver or into the ends of fiber-optic cables. Fiber-optic transceivers and fiber-optic cables connected to transceivers emit laser light that can damage your eyes.

2. Carefully unplug the fiber-optic cable connector from the transceiver.
3. Cover the transceiver with a rubber safety cap.



**LASER WARNING:** Do not leave a fiber-optic transceiver uncovered except when inserting or removing a cable. The rubber safety cap keeps the port clean and protects your eyes from accidental exposure to laser light.

4. Cover the fiber-optic cable connector with the rubber safety cap.

## Connect a Fiber-Optic Cable

Before you connect a fiber-optic cable to an optical transceiver installed in a device, ensure that you have taken the necessary precautions for safe handling of lasers (see [Laser and LED Safety Guidelines and Warnings](#)).

To connect a fiber-optic cable to an optical transceiver installed in a device:



**LASER WARNING:** Do not look directly into a fiber-optic transceiver or into the ends of fiber-optic cables. Fiber-optic transceivers and fiber-optic cables connected to transceivers emit laser light that can damage your eyes.

1. If the fiber-optic cable connector is covered with a rubber safety cap, remove the cap. Save the cap.
2. Remove the rubber safety cap from the optical transceiver. Save the cap.
3. Insert the cable connector into the optical transceiver (see [Figure 75 on page 155](#)).

**Figure 75: Connect a Fiber-Optic Cable to an Optical Transceiver Installed in a Device**

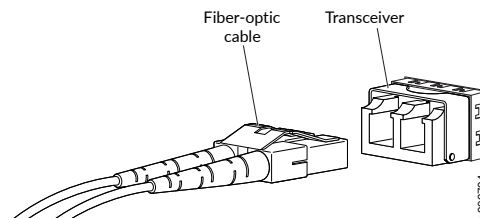

4. Secure the cables so that they do not support their own weight. Place excess cable out of the way in a neatly coiled loop. Placing fasteners on a loop helps cables maintain their shape.



**CAUTION:** Do not bend fiber-optic cables beyond their minimum bend radius. An arc smaller than a few inches in diameter can damage the cables and cause problems that are difficult to diagnose.

Do not let fiber-optic cables hang free from the connector. Do not allow fastened loops of cables to dangle, which stresses the cables at the fastening point.

## How to Handle Fiber-Optic Cables

Fiber-optic cables connect to optical transceivers that are installed in Juniper Networks devices.

Follow these guidelines when handling fiber-optic cables:

- When you unplug a fiber-optic cable from a transceiver, place rubber safety caps over the transceiver and on the end of the cable.
- Anchor fiber-optic cables to prevent stress on the connectors. When attaching a fiber-optic cable to a transceiver, be sure to secure the fiber-optic cable so that it does not support its own weight as it hangs to the floor. Never let a fiber-optic cable hang free from the connector.
- Avoid bending the fiber-optic cables beyond their minimum bend radius. Bending fiber-optic cables into arcs smaller than a few inches in diameter can damage the cables and cause problems that are difficult to diagnose.
- Frequent plugging and unplugging of fiber-optic cables in and out of optical instruments can damage the instruments, which are expensive to repair. To prevent damage from overuse, attach a short fiber extension to the optical equipment. The short fiber extension absorbs wear and tear due to frequent plugging and unplugging. Replacing the short fiber extension is easier and cost efficient compared with replacing the instruments.
- Keep fiber-optic cable connections clean. Microdeposits of oil and dust in the canal of the transceiver or cable connector can cause loss of light, reduction in signal power, and possibly intermittent problems with the optical connection.
  - To clean the transceiver canal, use an appropriate fiber-cleaning device such as RIFOCS Fiber Optic Adaptor Cleaning Wands (part number 946). Follow the instructions in the cleaning kit you use.
  - After cleaning the transceiver, make sure that the connector tip of the fiber-optic cable is clean. Use only an approved alcohol-free fiber-optic cable cleaning kit such as the Optex Cletop-S® Fiber Cleaner. Follow the instructions in the cleaning kit you use.

# Powering Off a QFX5110

Before you remove the power cord to power off a QFX5110:

- Ensure that you have taken the necessary precautions to prevent electrostatic discharge (ESD) damage. See [Prevention of Electrostatic Discharge Damage](#).
- Ensure that you do not need to forward traffic through the switch.

Ensure that you have the following parts and tools available to power off the switch:

- An ESD grounding strap
- An external management device such as a PC
- An RJ-45 to DB-9 rollover cable to connect the external management device to the console port

To power off a QFX5110 switch:

1. Connect to the switch using one of the following methods:

- Connect a management device to the console (**CON**) port on a QFX5110. For instructions about connecting a management device to the console (**CON**) port, see ["Connect a Device to a Management Console Using an RJ-45 Connector" on page 119](#).
- You can shut down the QFX5110 from a management device on your out-of-band management network. For instructions about connecting a management device to the management (**CO**) port, see ["Connect a Device to a Network for Out-of-Band Management" on page 118](#).

2. Shut down Junos OS from the external management device by issuing the request `system halt` operational mode CLI command. This command shuts down the switch gracefully and preserves system state information. A message appears on the console, confirming that the operating system has halted.

You see the following output (or something similar, depending on the hardware being shut down) after entering the command:

```
System going down in 1 minute

*** System shutdown message from root@ ***

System going down in 30 seconds

*** FINAL System shutdown message from root@ ***
```

```

System going down IMMEDIATELY

Stopping cron.
Waiting for PIDS: 3494.
.
.
Waiting (max 60 seconds) for system process `vnlru' to stop...done
Waiting (max 60 seconds) for system process `bufdaemon' to stop...done
Waiting (max 60 seconds) for system process `syncer' to stop...
Syncing disks, vnodes remaining...0 0 0 0 done
All buffers synced.
Uptime: 3m26s
usb0: controller did not stop
unloading fpga driver
Khelf module "jsocket" can't unload until its refcount drops from 5 to 0.
Rebooting...
cpu_reset: Stopping other CPUs
Consoles: serial port
BIOS drive C: is disk0
BIOS drive D: is disk1
BIOS drive E: is disk2
BIOS drive F: is disk3
BIOS 639kB/3144576kB available memory

```



**CAUTION:** The final output of any version of the `request system halt` command is “The operating system has halted.” Wait at least 60 seconds after first seeing this message before following the instructions in [Step 4](#) and [Step 5](#) to power off the switch.

3. Attach the grounding strap to your bare wrist and to a site ESD point.
4. Disconnect power to the switch by performing one of the following tasks:
  - AC power supply—If the AC power source outlet has a power switch, set it to the off (O) position. If the AC power source outlet does not have a power switch, gently pull out the plug end of the power cord connected to the power source outlet.
  - DC power supply—Switch the circuit breaker on the panel board that services the DC circuit to the off position.
5. Remove the power source cable from the power supply faceplate:
  - AC power supply—Remove the power cord from the power supply faceplate by detaching the power cord retainer and gently pulling out the socket end of the power cord connected to the power supply faceplate.

- DC power supply—Remove the screws securing the ring lugs attached to the power source cables to the power supply using the screwdriver, and remove the power source cables from the power supply. Replace the screws on the terminals and tighten them.
6. Uncable the switch before removing it from the rack or cabinet.

#### RELATED DOCUMENTATION

[QFX5110 Power System | 45](#)

[Connecting the QFX5110 to Power | 121](#)

## Removing a QFX5110 from a Rack

Before removing a QFX5110 from a rack:

Ensure that you have the following parts and tools available:

- A Phillips (+) screwdriver, number 2 or number 3, depending on the size of your rack mounting screws, for removing the QFX5110 from the rack.

If you need to relocate an installed QFX5110, use the procedure described in this topic.

**NOTE:** When you remove multiple switches from a rack, remove the switch in the top of the rack first, then proceed to remove the rest of the switches from top to bottom.

- Ensure that the rack is stable and secured to the building.
- Ensure that there is enough space to place the removed QFX5110 in its new location and along the path to the new location.
- Read [General Safety Guidelines and Warnings](#).
- Use the power off sequence described in "[Powering Off a QFX5110](#)" on [page 157](#) to safely power off the device.
- Disconnect the power cords.
- Ensure that you have disconnected any cables or wires attached to the QFX5110 switch ports or Precision Time Protocol (PTP) ports.

To remove a QFX5110 from a rack or cabinet:



1. Have one person support the weight of the switch while another person uses the screwdriver to remove the front mounting screws that attach the chassis mounting brackets to the rack or cabinet.
2. Remove the QFX5110 from the rack or cabinet.
3. Use the screwdriver to remove the mounting screws that attach the mounting blades attached to the rear of the rack or cabinet.
4. Place the removed screws and mounting blades in a labeled bag. You will need them when you reinstall the chassis.
5. Transport the QFX5110 to your new location.

### RELATED DOCUMENTATION

| [Mounting a QFX5110 in a Rack](#) | 105

# 6

CHAPTER

## Troubleshooting Hardware

---

[Troubleshooting the QFX5110](#) | 162

---

# Troubleshooting the QFX5110

## IN THIS SECTION

- [QFX5120 Troubleshooting Resources Overview | 162](#)
- [QFX Series Alarm Messages Overview | 163](#)
- [Chassis Alarm Messages | 163](#)

## QFX5120 Troubleshooting Resources Overview

To troubleshoot a QFX5120, you use the Junos OS CLI, alarms, and LEDs on the network ports, management panel, and components.

- LEDs—When the Routing Engine detects an alarm condition, it lights the red or yellow alarm LED on the management panel as appropriate. In addition, you can also use component LEDs and network port LEDs to troubleshoot the QFX5120. For more information, see the following topics:
  - ["QFX5110 Chassis Status LEDs" on page 33](#)
  - ["QFX5110 Management Port LEDs" on page 32](#)
  - ["QFX5110 Network Port LEDs" on page 28](#)
  - ["QFX5110 Fan Module LED" on page 43](#)
  - ["QFX5110 AC Power Supply LEDs" on page 50](#) and ["QFX5110 DC Power Supply LEDs" on page 55](#)
- CLI—The CLI is the primary tool for controlling and troubleshooting hardware, Junos OS, routing protocols, and network connectivity. CLI commands display information from routing tables, information specific to routing protocols, and information about network connectivity derived from the ping and traceroute utilities. For information about using the CLI to troubleshoot Junos OS, see the appropriate Junos OS configuration guide.
- JTAC—If you need assistance during troubleshooting, you can contact the Juniper Networks Technical Assistance Center (JTAC) by using the Web or by telephone. If you encounter software problems, or problems with hardware components not discussed here, contact JTAC.
- Knowledge Base articles—[Knowledge Base](#).

## QFX Series Alarm Messages Overview

When a QFX Series switch detects an alarm condition, it lights the red or yellow alarm LED on the management panel as appropriate. To view a more detailed description of the alarm cause, issue the `show chassis alarms` CLI command:

```
user@host> show chassis alarms
6 alarms currently active
Alarm time          Class Description
2018-02-07 12:12:18 PST Major FPC Management1 Ethernet Link Down
2018-02-07 12:11:54 PST Minor FPC0: LED 3:Alarm LED Read Error
2018-02-07 12:11:54 PST Minor FPC0: LED 3:Alarm LED Write Error
2018-02-07 12:11:54 PST Major FPC0: PEM 1 Not Supported
2018-02-07 12:11:54 PST Major FPC0: PEM 0 Not Supported
2018-02-07 12:11:54 PST Major FPC0: PEM 0 Not Powered
```

For Junos OS Evolved systems, `show system alarms` CLI command indicates major and minor alarms on the system. In this example from a Junos OS Evolved system, a fan tray error is shown in slot **4**.

```
user@host> show system alarms
2 alarms currently active
Alarm time          Class Description
2018-11-15 11:52:22 PST Major Fan Tray 4 Failure <<<<<
2018-11-15 10:40:08 PST Minor Host 0 Disk 2 Labelled incorrectly
```

## Chassis Alarm Messages

Chassis alarms indicate a failure on the device or one of its components. Chassis alarms are preset and cannot be modified.

Chassis alarms on QFX5100, QFX5110, QFX5210, and QFX5120 devices have two severity levels:

- **Major (red)**—Indicates a critical situation on the device that has resulted from one of the conditions described in [Table 38 on page 164](#). A red alarm condition requires immediate action.
- **Minor (yellow)**—Indicates a noncritical condition on the device that, if left unchecked, might cause an interruption in service or degradation in performance. A yellow alarm condition requires monitoring or maintenance.

Table 38 on page 164 describes the chassis alarm messages on QFX5100, QFX5110, QFX5200, QFX5210, and QFX5120 devices.

**Table 38: Chassis Alarm Messages**

Component	Alarm Type	CLI Message	Recommended Action
Fans	Major (red)	Fan Failure	Replace the fan module and report the failure to customer support.
		Fan I2C Failure	Check the system log for one of the following error messages and report the message to customer support: <ul style="list-style-type: none"> <li>• CM ENV Monitor: Get fan speed failed.</li> <li>• <i>fan-number</i> is NOT spinning @ correct speed, where <i>fan-number</i> can be 1, 2, 3, 4, or 5.</li> </ul>
		Fan <i>fan-number</i> Not Spinning	Remove and check the fan module for obstructions, and then reinsert the fan module. If the problem persists, replace the fan module.
	Minor (yellow)	Fan/Blower Absent	Check the system log for the error message <i>fan-number</i> Absent, where <i>fan-number</i> can be 1, 2, 3, 4, or 5.  Install fan modules in the slots where they are absent.
Power supplies	Major (red)	PEM <i>pem-number</i> Airflow not matching Chassis Airflow	Replace the power supply with a power supply that supports the same airflow direction as supported by the chassis.

Table 38: Chassis Alarm Messages (Continued)

Component	Alarm Type	CLI Message	Recommended Action
		PEM <i>pem-number</i> I2C Failure	<p>Check the system log for one of the following error messages and report the message to customer support:</p> <ul style="list-style-type: none"> <li>• I2C Read failed for device <i>number</i>, where <i>number</i> where <i>number</i> ranges from 123 through 125.</li> <li>• PS <i>number</i>: Transitioning from online to offline, where power supply <i>number</i> is 1 or 2.</li> </ul>
		PEM <i>pem-number</i> is not powered	Check the power cord connection and reconnect, if necessary.
		PEM <i>pem-number</i> is not supported	Replace the power supply with a supported power supply.
		PEM <i>pem-number</i> Not OK	Indicates a problem with the incoming AC power or outgoing DC power. Report the error to customer support.
	Minor (yellow)	PEM <i>pem-number</i> Absent	<p>Reboot the switch after removing one of the power supply. The switch can continue to operate with a single power supply.</p> <p>OR</p> <p>Replace the removed power supply and reboot the switch.</p>
		PEM <i>pem-number</i> Power Supply Type Mismatch	Check whether there is a mix of AC and DC power supplies in the same chassis. Reboot the switch with only AC or only DC power supplies.

Table 38: Chassis Alarm Messages (Continued)

Component	Alarm Type	CLI Message	Recommended Action
		PEM <i>pem-number</i> Removed	Replace the removed power supply or reboot the switch. The switch can continue to operate with a single power supply.
Temperature sensors	Major (red)	<i>sensor-location</i> Temp Sensor Fail	Check the system log for the following error message and report the message to customer support:  Temp sensor <i>sensor-number</i> failed, where <i>sensor-number</i> ranges from 1 through 10.
		<i>sensor-location</i> Temp Sensor Too Hot	Check environmental conditions and alarms on other devices. Ensure that environmental factors (such as hot air blowing around the equipment) do not affect the temperature sensor. If the condition persists, the device might shut down.
	Minor (yellow)	<i>sensor-location</i> Temp Sensor Too Warm	Check environmental conditions and alarms on other devices. Ensure that environmental factors (such as hot air blowing around the equipment) do not affect the temperature sensor.
Routing Engine	Minor (yellow)	RE <i>RE number</i> /var partition usage is high	Clean up the system file storage space on the switch. For more information, see <i>Cleaning Up the System File Storage Space</i> .
	Major (red)	RE <i>RE number</i> /var partition is full	Clean up the system file storage space on the switch. For more information, see <i>Cleaning Up the System File Storage Space</i> .

Table 38: Chassis Alarm Messages (Continued)

Component	Alarm Type	CLI Message	Recommended Action
	Minor (yellow)	Rescue configuration is not set	Use the <b>request system configuration rescue save</b> command to set the rescue configuration. For more information, see <i>Setting or Deleting the Rescue Configuration</i> .
		<i>Feature</i> usage requires a license or License for <i>feature</i> expired	Install the required license for the feature specified in the alarm. For more information, see <i>Software Features That Require Licenses on the QFX Series</i> .
Management Ethernet interface	Major (red)	Management Ethernet 1 Link Down	<p>Check whether a cable is connected to the management Ethernet interface, or whether the cable is defective. Replace the cable, if required.</p> <p>On models that have both em0 and em1 management interfaces available, you must connect both interfaces. If both interfaces are not connected, the alarm is raised. However, the alarm has no service impact.</p> <p>If you are unable to resolve the problem, open a support case by using the Case Manager link at <a href="https://www.juniper.net/support/">https://www.juniper.net/support/</a> or call 1-888-314-5822 (tollfree, US or 1-408-745-9500 (from outside the United States).</p>

## RELATED DOCUMENTATION

QFX5110 Management Panel | 30

Contact Customer Support to Obtain a Return Material Authorization | 169



# 7

CHAPTER

## Contacting Customer Support and Returning the Chassis or Components

---

[Contact Customer Support to Obtain a Return Material Authorization](#) | 169

[Returning the QFX5110 Chassis or Components](#) | 170

---

# Contact Customer Support to Obtain a Return Material Authorization

If you need to return a device or hardware component to Juniper Networks for repair or replacement, obtain an RMA number from JTAC. You must obtain an RMA number before you attempt to return the component.

After locating the serial number of the device or hardware component you want to return, open a service request with the JTAC on the Web or by telephone.

Before you request an RMA number from JTAC, be prepared to provide the following information:

- Your existing service request number, if you have one
- Serial number of the component
- Your name, organization name, telephone number, fax number, and shipping address
- Details of the failure or problem
- Type of activity being performed on the device when the problem occurred
- Configuration data displayed by one or more `show` commands

You can contact JTAC 24 hours a day, seven days a week, on the Web or by telephone:

- Service Request Manager: <https://support.juniper.net/support>
- Telephone: +1-888-314-JTAC (+1-888-314-5822), toll free in U.S., Canada, and Mexico

**NOTE:** For international or direct-dial options in countries without toll free numbers, see <https://support.juniper.net/support>.

If you are contacting JTAC by telephone, enter your 12-digit service request number followed by the pound (#) key for an existing case, or press the star (\*) key to be routed to the next available support engineer.

The support representative validates your request and issues an RMA number for return of the component.

# Returning the QFX5110 Chassis or Components

## IN THIS SECTION

- [Locating the Serial Number on a QFX5110 Device or Component | 170](#)
- [How to Return a Hardware Component to Juniper Networks, Inc. | 173](#)
- [Guidelines for Packing Hardware Components for Shipment | 174](#)

## Locating the Serial Number on a QFX5110 Device or Component

### IN THIS SECTION

- [Listing the Chassis and Component Details Using the CLI | 171](#)
- [Locating the Chassis Serial Number ID Label on a QFX5110 | 172](#)
- [Locating the Serial Number ID Labels on FRU Components | 172](#)

If you are returning a switch or component to Juniper Networks for repair or replacement, you must locate the serial number of the switch or component. You must provide the serial number to the Juniper Networks Technical Assistance Center (JTAC) when you contact them to obtain a Return Materials Authorization (RMA). See [Contact Customer Support to Obtain Return Material Authorization](#).

If the switch is operational and you can access the command-line interface (CLI), you can list serial numbers for the switch and for some components with a CLI command. If you do not have access to the CLI or if the serial number for the component does not appear in the command output, you can locate the serial number ID label on the switch or component.

**NOTE:** If you want to find the serial number ID label on a component, you need to remove the component from the switch chassis, for which you must have the required parts and tools available.

## Listing the Chassis and Component Details Using the CLI

To list the QFX5110 switch and components and their serial numbers, use the `show chassis hardware` CLI operational mode command.

```

user@device> show chassis hardware

user@device> show chassis hardware
Hardware inventory:
Item          Version  Part number  Serial number  Description
Chassis                               WS3115130011  QFX5110-48S-4Q
Pseudo CB 0
Routing Engine 0      BUILTIN    BUILTIN        RE-QFX5110-48S-4Q
FPC 0              REV 03     650-061152    WS3115290015
  CPU              BUILTIN    BUILTIN        FPC CPU
  PIC 0            BUILTIN    BUILTIN        48x10G-4x100G
    Xcvr 34        REV 01     740-030658    AD1148A0AXP    SFP+-10G-USR
    Xcvr 35        REV 01     740-030658    AD1148A0APE    SFP+-10G-USR
    Xcvr 48        REV01     740-061001    LE0150600KQ    QSFP28-100G-CU3M
    Xcvr 49        REV01     740-061001    LE0150600KQ    QSFP28-100G-CU3M
    Xcvr 50        REV 01     740-038624    MOC13346240015 QSFP+-40G-CU3M
Power Supply 0      REV 03     740-041741    1GA24141198    JPSU-650W-AC-AFO
Power Supply 1      REV 03     740-041741    1GA24141173    JPSU-650W-AC-AFO
Fan Tray 0          fan-ctrl-2 0, Front to Back Airflow -
AFO
Fan Tray 1          fan-ctrl-2 1, Front to Back Airflow -
AFO
Fan Tray 2          fan-ctrl-2 2, Front to Back Airflow -
AFO
Fan Tray 3          fan-ctrl-2 3, Front to Back Airflow -
AFO
Fan Tray 4          fan-ctrl-2 4, Front to Back Airflow -
AFO

{master:0}
root>

```

**NOTE:** You must remove the fan module to read the fan serial number from the serial number ID label. The fan module serial number cannot be viewed through the CLI. **Fan Tray 2** refers to the third module from the left, counting from 0.

## Locating the Chassis Serial Number ID Label on a QFX5110

The chassis serial number ID label is located on the right side of the QFX5110 port panel. On legacy switches, or switches with an LCD, the port panel is referred to as the front panel. See [Figure 76 on page 172](#) for an example of where to find the serial number ID.

**Figure 76: Location of the Serial Number ID Label on a QFX5110**

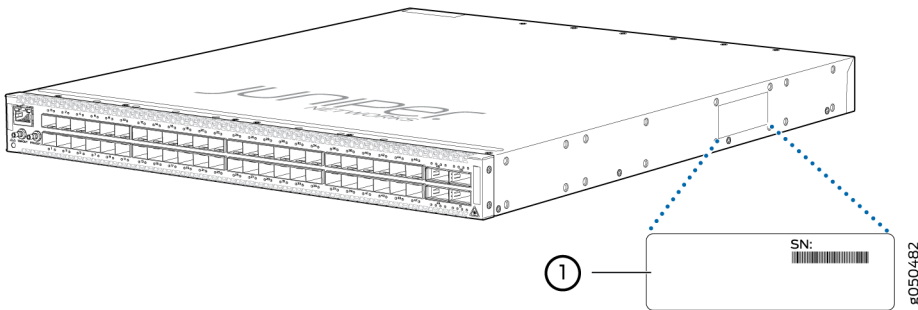

## Locating the Serial Number ID Labels on FRU Components

The power supplies and fan modules installed in a QFX5110 are field-replaceable units (FRUs). For each FRU, you must remove the FRU from the switch chassis to see the FRU serial number ID label.

- AC power supply—The serial number ID label is on the top of the AC power supply. See [Figure 77 on page 173](#) for an example of where to find the serial number ID.

Figure 77: Location of the AC Power Supply Serial Number ID Label on a QFX5110

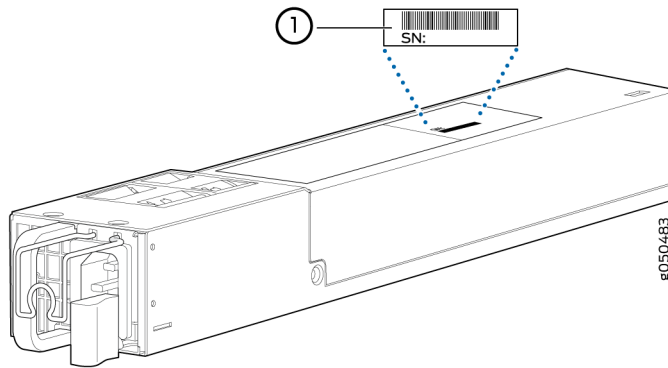

1– AC power supply serial number

- Fan module—The serial number ID label is on the bottom of the fan bezel. See [Figure 78 on page 173](#) for an example of where to find the serial number ID.

Figure 78: Location of the Fan Module Serial Number ID Label on a QFX5110-48S

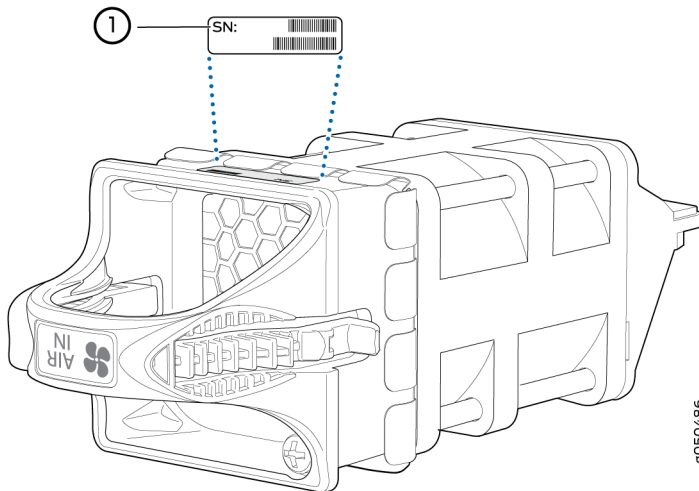

1– Fan module serial number

## How to Return a Hardware Component to Juniper Networks, Inc.

If a hardware component fails, please contact Juniper Networks, Inc. to obtain a Return Material Authorization (RMA) number. This number is used to track the returned material at the factory and to return repaired or new components to the customer as needed.

**NOTE:** Do not return any component to Juniper Networks, Inc. unless you have first obtained an RMA number. Juniper Networks, Inc. reserves the right to refuse shipments that do not have an RMA. Refused shipments are returned to the customer by collect freight.

For more information about return and repair policies, see the customer support webpage at <https://support.juniper.net/support/>.

For product problems or technical support issues, contact the Juniper Networks Technical Assistance Center (JTAC) by using the Service Request Manager link at <https://support.juniper.net/support/> or at 1-888-314-JTAC (within the United States) or 1-408-745-9500 (from outside the United States).

To return a defective hardware component:

1. Determine the part number and serial number of the defective component.
2. Obtain an RMA number from the Juniper Networks Technical Assistance Center (JTAC). You can send e-mail or telephone as described above.
3. Provide the following information in your e-mail message or during the telephone call:
  - Part number and serial number of component
  - Your name, organization name, telephone number, and fax number
  - Description of the failure
4. The support representative validates your request and issues an RMA number for return of the component.
5. Pack the component for shipment.

## Guidelines for Packing Hardware Components for Shipment

To pack and ship individual components:

- When you return components, make sure that they are adequately protected with packing materials and packed so that the pieces are prevented from moving around inside the carton.
- Use the original shipping materials if they are available.
- Place individual components in antistatic bags.
- Write the RMA number on the exterior of the box to ensure proper tracking.



**CAUTION:** Do not stack any of the hardware components.

#### RELATED DOCUMENTATION

| [Contact Customer Support to Obtain a Return Material Authorization](#) | 169



# 8

CHAPTER

## Safety and Compliance Information

---

General Safety Guidelines and Warnings | 178

Definitions of Safety Warning Levels | 179

Qualified Personnel Warning | 181

Warning Statement for Norway and Sweden | 181

Fire Safety Requirements | 182

Installation Instructions Warning | 183

Restricted Access Warning | 184

Ramp Warning | 185

Rack-Mounting and Cabinet-Mounting Warnings | 186

Grounded Equipment Warning | 190

Radiation from Open Port Apertures Warning | 190

Laser and LED Safety Guidelines and Warnings for the QFX Series | 192

Maintenance and Operational Safety Guidelines and Warnings | 195

General Electrical Safety Guidelines and Warnings | 200

Action to Take After an Electrical Accident | 202

Prevention of Electrostatic Discharge Damage | 202

AC Power Electrical Safety Guidelines | 204

AC Power Disconnection Warning | 205

DC Power Electrical Safety Guidelines | 206

DC Power Disconnection Warning | 207

DC Power Grounding Requirements and Warning | 209

DC Power Wiring Sequence Warning | 209

DC Power Wiring Terminations Warning | 211

Multiple Power Supplies Disconnection Warning | 212

TN Power Warning | 213

QFX5110 Agency Approvals | 214

---

# General Safety Guidelines and Warnings

The following guidelines help ensure your safety and protect the device from damage. The list of guidelines might not address all potentially hazardous situations in your working environment, so be alert and exercise good judgment at all times.

- Perform only the procedures explicitly described in the hardware documentation for this device. Make sure that only authorized service personnel perform other system services.
- Keep the area around the device clear and free from dust before, during, and after installation.
- Keep tools away from areas where people could trip over them while walking.
- Do not wear loose clothing or jewelry, such as rings, bracelets, or chains, which could become caught in the device.
- Wear safety glasses if you are working under any conditions that could be hazardous to your eyes.
- Do not perform any actions that create a potential hazard to people or make the equipment unsafe.
- Never attempt to lift an object that is too heavy for one person to handle.
- Never install or manipulate wiring during electrical storms.
- Never install electrical jacks in wet locations unless the jacks are specifically designed for wet environments.
- Operate the device only when it is properly grounded.
- Follow the instructions in this guide to properly ground the device to earth.
- Replace fuses only with fuses of the same type and rating.
- Do not open or remove chassis covers or sheet-metal parts unless instructions are provided in the hardware documentation for this device. Such an action could cause severe electrical shock.
- Do not push or force any objects through any opening in the chassis frame. Such an action could result in electrical shock or fire.
- Avoid spilling liquid onto the chassis or onto any device component. Such an action could cause electrical shock or damage the device.
- Avoid touching uninsulated electrical wires or terminals that have not been disconnected from their power source. Such an action could cause electrical shock.

- Some parts of the chassis, including AC and DC power supply surfaces, power supply unit handles, SFB card handles, and fan tray handles might become hot. The following label provides the warning for hot surfaces on the chassis:



- Always ensure that all modules, power supplies, and cover panels are fully inserted and that the installation screws are fully tightened.

## Definitions of Safety Warning Levels

The documentation uses the following levels of safety warnings (there are two *Warning* formats):

**NOTE:** You might find this information helpful in a particular situation, or you might overlook this important information if it was not highlighted in a Note.



**CAUTION:** You need to observe the specified guidelines to prevent minor injury or discomfort to you or severe damage to the device.

**Attention** Veillez à respecter les consignes indiquées pour éviter toute incommodité ou blessure légère, voire des dégâts graves pour l'appareil.



**LASER WARNING:** This symbol alerts you to the risk of personal injury from a laser.

**Avertissement** Ce symbole signale un risque de blessure provoquée par rayon laser.



**WARNING:** This symbol means danger. You are in a situation that could cause bodily injury. Before you work on any equipment, be aware of the hazards involved with electrical circuitry, and familiarize yourself with standard practices for preventing accidents.

**Waarschuwing** Dit waarschuwingssymbool betekent gevaar. U verkeert in een situatie die lichamelijk letsel kan veroorzaken. Voordat u aan enige apparatuur gaat werken, dient u zich bewust te zijn van de bij elektrische schakelingen betrokken risico's en dient u op de hoogte te zijn van standaard maatregelen om ongelukken te voorkomen.

**Varoitus** Tämä varoitusmerkki merkitsee vaaraa. Olet tilanteessa, joka voi johtaa ruumiinvammaan. Ennen kuin työskentelet minkään laitteiston parissa, ota selvää sähkökytkentöihin liittyvistä vaaroista ja tavanomaisista onnettomuuksien ehkäisykeinoista.

**Avertissement** Ce symbole d'avertissement indique un danger. Vous vous trouvez dans une situation pouvant causer des blessures ou des dommages corporels. Avant de travailler sur un équipement, soyez conscient des dangers posés par les circuits électriques et familiarisez-vous avec les procédures couramment utilisées pour éviter les accidents.

**Warnung** Dieses Warnsymbol bedeutet Gefahr. Sie befinden sich in einer Situation, die zu einer Körperverletzung führen könnte. Bevor Sie mit der Arbeit an irgendeinem Gerät beginnen, seien Sie sich der mit elektrischen Stromkreisen verbundenen Gefahren und der Standardpraktiken zur Vermeidung von Unfällen bewußt.

**Avvertenza** Questo simbolo di avvertenza indica un pericolo. La situazione potrebbe causare infortuni alle persone. Prima di lavorare su qualsiasi apparecchiatura, occorre conoscere i pericoli relativi ai circuiti elettrici ed essere al corrente delle pratiche standard per la prevenzione di incidenti.

**Advarsel** Dette varselsymbolet betyr fare. Du befinner deg i en situasjon som kan føre til personskade. Før du utfører arbeid på utstyr, må du være oppmerksom på de faremomentene som elektriske kretser innebærer, samt gjøre deg kjent med vanlig praksis når det gjelder å unngå ulykker.

**Aviso** Este símbolo de aviso indica perigo. Encontra-se numa situação que lhe poderá causar danos físicos. Antes de começar a trabalhar com qualquer equipamento, familiarize-se com os perigos relacionados com circuitos eléctricos, e com quaisquer práticas comuns que possam prevenir possíveis acidentes.

**¡Atención!** Este símbolo de aviso significa peligro. Existe riesgo para su integridad física. Antes de manipular cualquier equipo, considerar los riesgos que entraña la corriente eléctrica y familiarizarse con los procedimientos estándar de prevención de accidentes.

**Varning!** Denna varningssymbol signalerar fara. Du befinner dig i en situation som kan leda till personskada. Innan du utför arbete på någon utrustning måste du vara medveten om farorna med elkretsar och känna till vanligt förfarande för att förebygga skador.

## Qualified Personnel Warning



**WARNING:** Only trained and qualified personnel should install or replace the device.

**Waarschuwing** Installatie en reparaties mogen uitsluitend door getraind en bevoegd personeel uitgevoerd worden.

**Varoitus** Ainoastaan koulutettu ja pätevä henkilökunta saa asentaa tai vaihtaa tämän laitteen.

**Avertissement** Tout installation ou remplacement de l'appareil doit être réalisé par du personnel qualifié et compétent.

**Warnung** Gerät nur von geschultem, qualifiziertem Personal installieren oder auswechseln lassen.

**Avvertenza** Solo personale addestrato e qualificato deve essere autorizzato ad installare o sostituire questo apparecchio.

**Advarsel** Kun kvalifisert personell med riktig opplæring bør montere eller bytte ut dette utstyret.

**Aviso** Este equipamento deverá ser instalado ou substituído apenas por pessoal devidamente treinado e qualificado.

**¡Atención!** Estos equipos deben ser instalados y reemplazados exclusivamente por personal técnico adecuadamente preparado y capacitado.

**Varning!** Denna utrustning ska endast installeras och bytas ut av utbildad och kvalificerad personal.

## Warning Statement for Norway and Sweden



**WARNING:** The equipment must be connected to an earthed mains socket-outlet.

**Advarsel** Apparatet skal kobles til en jordet stikkontakt.

**Varning!** Apparaten skall anslutas till jordat nätuttag.

# Fire Safety Requirements

## IN THIS SECTION

- [Fire Suppression | 182](#)
- [Fire Suppression Equipment | 182](#)

In the event of a fire emergency, the safety of people is the primary concern. You should establish procedures for protecting people in the event of a fire emergency, provide safety training, and properly provision fire-control equipment and fire extinguishers.

In addition, you should establish procedures to protect your equipment in the event of a fire emergency. Juniper Networks products should be installed in an environment suitable for electronic equipment. We recommend that fire suppression equipment be available in the event of a fire in the vicinity of the equipment and that all local fire, safety, and electrical codes and ordinances be observed when you install and operate your equipment.

## Fire Suppression

In the event of an electrical hazard or an electrical fire, you should first turn power off to the equipment at the source. Then use a Type C fire extinguisher, which uses noncorrosive fire retardants, to extinguish the fire.

## Fire Suppression Equipment

Type C fire extinguishers, which use noncorrosive fire retardants such as carbon dioxide and Halotron™, are most effective for suppressing electrical fires. Type C fire extinguishers displace oxygen from the point of combustion to eliminate the fire. For extinguishing fire on or around equipment that draws air from the environment for cooling, you should use this type of inert oxygen displacement extinguisher instead of an extinguisher that leaves residues on equipment.

Do not use multipurpose Type ABC chemical fire extinguishers (dry chemical fire extinguishers). The primary ingredient in these fire extinguishers is monoammonium phosphate, which is very sticky and

difficult to clean. In addition, in the presence of minute amounts of moisture, monoammonium phosphate can become highly corrosive and corrodes most metals.

Any equipment in a room in which a chemical fire extinguisher has been discharged is subject to premature failure and unreliable operation. The equipment is considered to be irreparably damaged.

**NOTE:** To keep warranties effective, do not use a dry chemical fire extinguisher to control a fire at or near a Juniper Networks device. If a dry chemical fire extinguisher is used, the unit is no longer eligible for coverage under a service agreement.

We recommend that you dispose of any irreparably damaged equipment in an environmentally responsible manner.

## Installation Instructions Warning



**WARNING:** Read the installation instructions before you connect the device to a power source.

**Waarschuwing** Raadpleeg de installatie-aanwijzingen voordat u het systeem met de voeding verbindt.

**Varoitus** Lue asennusohjeet ennen järjestelmän yhdistämistä virtälähteeseen.

**Avertissement** Avant de brancher le système sur la source d'alimentation, consulter les directives d'installation.

**Warnung** Lesen Sie die Installationsanweisungen, bevor Sie das System an die Stromquelle anschließen.

**Avvertenza** Consultare le istruzioni di installazione prima di collegare il sistema all'alimentatore.

**Advarsel** Les installasjonsinstruksjonene før systemet kobles til strømkilden.

**Aviso** Leia as instruções de instalação antes de ligar o sistema à sua fonte de energia.

**¡Atención!** Ver las instrucciones de instalación antes de conectar el sistema a la red de alimentación.

**Varning!** Läs installationsanvisningarna innan du kopplar systemet till dess strömförsörjningsenhet.



## Restricted Access Warning



**WARNING:** This unit is intended for installation in restricted access areas. A restricted access area is an area to which access can be gained only by service personnel through the use of a special tool, lock and key, or other means of security, and which is controlled by the authority responsible for the location.

**Waarschuwing** Dit toestel is bedoeld voor installatie op plaatsen met beperkte toegang. Een plaats met beperkte toegang is een plaats waar toegang slechts door servicepersoneel verkregen kan worden door middel van een speciaal instrument, een slot en sleutel, of een ander veiligheidsmiddel, en welke beheerd wordt door de overheidsinstantie die verantwoordelijk is voor de locatie.

**Varoitus** Tämä laite on tarkoitettu asennettavaksi paikkaan, johon pääsy on rajoitettua. Paikka, johon pääsy on rajoitettua, tarkoittaa paikkaa, johon vain huoltohenkilöstö pääsee jonkin erikoistyökalun, lukkoon sopivan avaimen tai jonkin muun turvalaitteen avulla ja joka on paikasta vastuussa olevien toimivaltaisten henkilöiden valvoma.

**Avertissement** Cet appareil est à installer dans des zones d'accès réservé. Ces dernières sont des zones auxquelles seul le personnel de service peut accéder en utilisant un outil spécial, un mécanisme de verrouillage et une clé, ou tout autre moyen de sécurité. L'accès aux zones de sécurité est sous le contrôle de l'autorité responsable de l'emplacement.

**Warnung** Diese Einheit ist zur Installation in Bereichen mit beschränktem Zutritt vorgesehen. Ein Bereich mit beschränktem Zutritt ist ein Bereich, zu dem nur Wartungspersonal mit einem Spezialwerkzeugs, Schloß und Schlüssel oder anderer Sicherheitsvorkehrungen Zugang hat, und der von dem für die Anlage zuständigen Gremium kontrolliert wird.

**Avvertenza** Questa unità deve essere installata in un'area ad accesso limitato. Un'area ad accesso limitato è un'area accessibile solo a personale di assistenza tramite un'attrezzo speciale, lucchetto, o altri dispositivi di sicurezza, ed è controllata dall'autorità responsabile della zona.

**Advarsel** Denne enheten er laget for installasjon i områder med begrenset adgang. Et område med begrenset adgang gir kun adgang til servicepersonale som bruker et spesielt verktøy, lås og nøkkel, eller en annen sikkerhetsanordning, og det kontrolleres av den autoriteten som er ansvarlig for området.

**Aviso** Esta unidade foi concebida para instalação em áreas de acesso restrito. Uma área de acesso restrito é uma área à qual apenas tem acesso o pessoal de serviço autorizado,

que possua uma ferramenta, chave e fechadura especial, ou qualquer outra forma de segurança. Esta área é controlada pela autoridade responsável pelo local.

**¡Atención!** Esta unidad ha sido diseñada para instalarse en áreas de acceso restringido. Área de acceso restringido significa un área a la que solamente tiene acceso el personal de servicio mediante la utilización de una herramienta especial, cerradura con llave, o algún otro medio de seguridad, y que está bajo el control de la autoridad responsable del local.

**Warning!** Denna enhet är avsedd för installation i områden med begränsat tillträde. Ett område med begränsat tillträde får endast tillträdas av servicepersonal med ett speciellt verktyg, lås och nyckel, eller annan säkerhetsanordning, och kontrolleras av den auktoritet som ansvarar för området.

## Ramp Warning



**WARNING:** When installing the device, do not use a ramp inclined at more than 10 degrees.

**Waarschuwing** Gebruik een oprijplaat niet onder een hoek van meer dan 10 graden.

**Varoitus** Älä käytä sellaista kaltevaa pintaa, jonka kaltevuus ylittää 10 astetta.

**Avertissement** Ne pas utiliser une rampe dont l'inclinaison est supérieure à 10 degrés.

**Warnung** Keine Rampen mit einer Neigung von mehr als 10 Grad verwenden.

**Avvertenza** Non usare una rampa con pendenza superiore a 10 gradi.

**Advarsel** Bruk aldri en rampe som heller mer enn 10 grader.

**Aviso** Não utilize uma rampa com uma inclinação superior a 10 graus.

**¡Atención!** No usar una rampa inclinada más de 10 grados.

**Warning!** Använd inte ramp med en lutning på mer än 10 grader.

## Rack-Mounting and Cabinet-Mounting Warnings

Ensure that the rack or cabinet in which the device is installed is evenly and securely supported. Uneven mechanical loading could lead to a hazardous condition.



**WARNING:** To prevent bodily injury when mounting or servicing the device in a rack, take the following precautions to ensure that the system remains stable. The following directives help maintain your safety:

- Install the device in a rack that is secured to the building structure.
- Mount the device at the bottom of the rack if it is the only unit in the rack.
- When mounting the device on a partially filled rack, load the rack from the bottom to the top, with the heaviest component at the bottom of the rack.
- If the rack is provided with stabilizing equipment, install the stabilizers before mounting or servicing the device in the rack.

**Waarschuwing** Om lichamelijk letsel te voorkomen wanneer u dit toestel in een rek monteert of het daar een servicebeurt geeft, moet u speciale voorzorgsmaatregelen nemen om ervoor te zorgen dat het toestel stabiel blijft. De onderstaande richtlijnen worden verstrekt om uw veiligheid te verzekeren:

- De Juniper Networks switch moet in een stellage worden geïnstalleerd die aan een bouwsel is verankerd.
- Dit toestel dient onderaan in het rek gemonteerd te worden als het toestel het enige in het rek is.
- Wanneer u dit toestel in een gedeeltelijk gevuld rek monteert, dient u het rek van onderen naar boven te laden met het zwaarste onderdeel onderaan in het rek.
- Als het rek voorzien is van stabiliseringshulpmiddelen, dient u de stabilisatoren te monteren voordat u het toestel in het rek monteert of het daar een servicebeurt geeft.

**Varoitus** Kun laite asetetaan telineeseen tai huolletaan sen ollessa telineessä, on noudatettava erityisiä varotoimia järjestelmän vakavuuden säilyttämiseksi, jotta vältetään loukkaantumiselta. Noudata seuraavia turvallisuusohjeita:

- Juniper Networks switch on asennettava telineeseen, joka on kiinnitetty rakennukseen.
- Jos telineessä ei ole muita laitteita, aseta laite telineen alaosaan.
- Jos laite asetetaan osaksi täytettyyn telineeseen, aloita kuormittaminen sen alaosasta kaikkein raskaimmalla esineellä ja siirry sitten sen yläosaan.
- Jos telinettä varten on vakaimet, asenna ne ennen laitteen asettamista telineeseen tai sen huoltamista siinä.

**Avertissement** Pour éviter toute blessure corporelle pendant les opérations de montage ou de réparation de cette unité en casier, il convient de prendre des précautions spéciales afin de maintenir la stabilité du système. Les directives ci-dessous sont destinées à assurer la protection du personnel:

- Le rack sur lequel est monté le Juniper Networks switch doit être fixé à la structure du bâtiment.
- Si cette unité constitue la seule unité montée en casier, elle doit être placée dans le bas.
- Si cette unité est montée dans un casier partiellement rempli, charger le casier de bas en haut en plaçant l'élément le plus lourd dans le bas.
- Si le casier est équipé de dispositifs stabilisateurs, installer les stabilisateurs avant de monter ou de réparer l'unité en casier.

**Warnung** Zur Vermeidung von Körperverletzung beim Anbringen oder Warten dieser Einheit in einem Gestell müssen Sie besondere Vorkehrungen treffen, um sicherzustellen, daß das System stabil bleibt. Die folgenden Richtlinien sollen zur Gewährleistung Ihrer Sicherheit dienen:

- Der Juniper Networks switch muß in einem Gestell installiert werden, das in der Gebäudestruktur verankert ist.
- Wenn diese Einheit die einzige im Gestell ist, sollte sie unten im Gestell angebracht werden.
- Bei Anbringung dieser Einheit in einem zum Teil gefüllten Gestell ist das Gestell von unten nach oben zu laden, wobei das schwerste Bauteil unten im Gestell anzubringen ist.

- Wird das Gestell mit Stabilisierungszubehör geliefert, sind zuerst die Stabilisatoren zu installieren, bevor Sie die Einheit im Gestell anbringen oder sie warten.

**Avvertenza** Per evitare infortuni fisici durante il montaggio o la manutenzione di questa unità in un supporto, occorre osservare speciali precauzioni per garantire che il sistema rimanga stabile. Le seguenti direttive vengono fornite per garantire la sicurezza personale:

- Il Juniper Networks switch deve essere installato in un telaio, il quale deve essere fissato alla struttura dell'edificio.
- Questa unità deve venire montata sul fondo del supporto, se si tratta dell'unica unità da montare nel supporto.
- Quando questa unità viene montata in un supporto parzialmente pieno, caricare il supporto dal basso all'alto, con il componente più pesante sistemato sul fondo del supporto.
- Se il supporto è dotato di dispositivi stabilizzanti, installare tali dispositivi prima di montare o di procedere alla manutenzione dell'unità nel supporto.

**Advarsel** Unngå fysiske skader under montering eller reparasjonsarbeid på denne enheten når den befinner seg i et kabinett. Vær nøye med at systemet er stabilt. Følgende retningslinjer er gitt for å verne om sikkerheten:

- Juniper Networks switch må installeres i et stativ som er forankret til bygningsstrukturen.
- Denne enheten bør monteres nederst i kabinettet hvis dette er den eneste enheten i kabinettet.
- Ved montering av denne enheten i et kabinett som er delvis fylt, skal kabinettet lastes fra bunnen og opp med den tyngste komponenten nederst i kabinettet.
- Hvis kabinettet er utstyrt med stabiliseringsutstyr, skal stabilisatorene installeres før montering eller utføring av reparasjonsarbeid på enheten i kabinettet.

**Aviso** Para se prevenir contra danos corporais ao montar ou reparar esta unidade numa estante, deverá tomar precauções especiais para se certificar de que o sistema possui um suporte estável. As seguintes directrizes ajudá-lo-ão a efectuar o seu trabalho com segurança:

- O Juniper Networks switch deverá ser instalado numa prateleira fixa à estrutura do edifício.

- Esta unidade deverá ser montada na parte inferior da estante, caso seja esta a única unidade a ser montada.
- Ao montar esta unidade numa estante parcialmente ocupada, coloque os itens mais pesados na parte inferior da estante, arrumando-os de baixo para cima.
- Se a estante possuir um dispositivo de estabilização, instale-o antes de montar ou reparar a unidade.

**¡Atención!** Para evitar lesiones durante el montaje de este equipo sobre un bastidor, oerriormente durante su mantenimiento, se debe poner mucho cuidado en que el sistema quede bien estable. Para garantizar su seguridad, proceda según las siguientes instrucciones:

- El Juniper Networks switch debe instalarse en un bastidor fijado a la estructura del edificio.
- Colocar el equipo en la parte inferior del bastidor, cuando sea la única unidad en el mismo.
- Cuando este equipo se vaya a instalar en un bastidor parcialmente ocupado, comenzar la instalación desde la parte inferior hacia la superior colocando el equipo más pesado en la parte inferior.
- Si el bastidor dispone de dispositivos estabilizadores, instalar éstos antes de montar o proceder al mantenimiento del equipo instalado en el bastidor.

**Varning!** För att undvika kroppsskada när du installerar eller utför underhållsarbete på denna enhet på en ställning måste du vidta särskilda försiktighetsåtgärder för att försäkra dig om att systemet står stadigt. Följande riktlinjer ges för att trygga din säkerhet:

- Juniper Networks switch måste installeras i en ställning som är förankrad i byggnadens struktur.
- Om denna enhet är den enda enheten på ställningen skall den installeras längst ned på ställningen.
- Om denna enhet installeras på en delvis fylld ställning skall ställningen fyllas nedifrån och upp, med de tyngsta enheterna längst ned på ställningen.
- Om ställningen är försedd med stabiliseringsdon skall dessa monteras fast innan enheten installeras eller underhålls på ställningen.

## Grounded Equipment Warning



**WARNING:** This device must be properly grounded at all times. Follow the instructions in this guide to properly ground the device to earth.

**Waarschuwing** Dit apparaat moet altijd goed geaard zijn. Volg de instructies in deze gids om het apparaat goed te aarden.

**Varoitus** Laitteen on oltava pysyvästi maadoitettu. Maadoita laite asianmukaisesti noudattamalla tämän oppaan ohjeita.

**Avertissement** L'appareil doit être correctement mis à la terre à tout moment. Suivez les instructions de ce guide pour correctement mettre l'appareil à la terre.

**Warnung** Das Gerät muss immer ordnungsgemäß geerdet sein. Befolgen Sie die Anweisungen in dieser Anleitung, um das Gerät ordnungsgemäß zu erden.

**Avvertenza** Questo dispositivo deve sempre disporre di una connessione a massa. Seguire le istruzioni indicate in questa guida per connettere correttamente il dispositivo a massa.

**Advarsel** Denne enheten på jordes skikkelig hele tiden. Følg instruksjonene i denne veiledningen for å jorde enheten.

**Aviso** Este equipamento deverá estar ligado à terra. Siga las instrucciones en esta guía para conectar correctamente este dispositivo a tierra.

**¡Atención!** Este dispositivo debe estar correctamente conectado a tierra en todo momento. Siga las instrucciones en esta guía para conectar correctamente este dispositivo a tierra.

**Warning!** Den här enheten måste vara ordentligt jordad. Följ instruktionerna i den här guiden för att jorda enheten ordentligt.

## Radiation from Open Port Apertures Warning



**LASER WARNING:** Because invisible radiation might be emitted from the aperture of the port when no fiber cable is connected, avoid exposure to radiation and do not stare into open apertures.

**Waarschuwing** Aangezien onzichtbare straling vanuit de opening van de poort kan komen als er geen fiberkabel aangesloten is, dient blootstelling aan straling en het kijken in open openingen vermeden te worden.

**Varoitus** Koska portin aukosta voi emittoitua näkymätöntä säteilyä, kun kuitukaapelia ei ole kytkettynä, vältä säteilylle altistumista äläkä katso avoimiin aukkoihin.

**Avertissement** Des radiations invisibles à l'il nu pouvant traverser l'ouverture du port lorsqu'aucun câble en fibre optique n'y est connecté, il est recommandé de ne pas regarder fixement l'intérieur de ces ouvertures.

**Warnung** Aus der Port-Öffnung können unsichtbare Strahlen emittieren, wenn kein Glasfaserkabel angeschlossen ist. Vermeiden Sie es, sich den Strahlungen auszusetzen, und starren Sie nicht in die Öffnungen!

**Avvertenza** Quando i cavi in fibra non sono inseriti, radiazioni invisibili possono essere emesse attraverso l'apertura della porta. Evitate di esporvi alle radiazioni e non guardate direttamente nelle aperture.

**Advarsel** Unngå utsettelse for stråling, og stirr ikke inn i åpninger som er åpne, fordi usynlig stråling kan emitteres fra portens åpning når det ikke er tilkoblet en fiberkabel.

**Aviso** Dada a possibilidade de emissão de radiação invisível através do orifício da via de acesso, quando esta não tiver nenhum cabo de fibra conectado, deverá evitar a EXposição à radiação e não deverá olhar fixamente para orifícios que se encontrarem a descoberto.

**¡Atención!** Debido a que la apertura del puerto puede emitir radiación invisible cuando no existe un cable de fibra conectado, evite mirar directamente a las aperturas para no exponerse a la radiación.

**Varning!** Osynlig strålning kan avges från en portöppning utan ansluten fiberkabel och du bör därför undvika att bli utsatt för strålning genom att inte stirra in i oskyddade öppningar.



# Laser and LED Safety Guidelines and Warnings for the QFX Series

## IN THIS SECTION

- [Class 1M Laser Product Warning | 192](#)
- [Class 1M Laser Radiation Warning | 193](#)
- [Unterminated Fiber-Optic Cable Warning | 193](#)

In addition to the general guidelines provided in [Laser and LED Safety Guidelines and Warnings](#), follow these warnings and guidelines that are specific to QFX Series devices.

QFX Series devices are equipped with laser transmitters:

- SFP and SFP+ transceivers are classified as Class 1 Laser Products (complies with 21 CFR 1040.10 and 1040.11 except for deviations pursuant to Laser Notice 50, dated July 26, 2001) or Class 1 LED Products.
- QSFP+ and QSFP28 transceivers are classified as Class 1M Laser Products (IEC 60825-1 2001-01).

Observe the following guidelines and warnings:

## Class 1M Laser Product Warning



**LASER WARNING:** Class 1M laser product.

**Waarschuwing** Laserproducten van Klasse 1M (IEC).

**Varoitus** Luokan 1M (IEC) lasertuotteita.

**Attention** Produits laser catégorie 1M (IEC).

**Warnung** Laserprodukte der Klasse 1M (IEC).

**Avvertenza** Prodotti laser di Classe 1M (IEC).

**Advarsel** Klasse 1M (IEC) laserprodukter.

**Aviso** Produtos laser Classe 1M (IEC).

**¡Atención!** Productos láser de Clase 1M (IEC).

**Varning!** Laserprodukter av Klass 1M (IEC).

## Class 1M Laser Radiation Warning



**LASER WARNING:** Class 1M laser radiation when open. Do not view directly with optical instruments.

## Unterminated Fiber-Optic Cable Warning



**WARNING:** Invisible laser radiation might be emitted from the unterminated connector of a fiber-optic cable. To avoid injury to your eye, do not view the fiber optics with a magnifying optical device, such as a loupe, within 100 mm.

**Waarschuwing** Er kunnen onzichtbare laserstralen worden uitgezonden vanuit het uiteinde van de onafgebroken vezelkabel of connector. Niet in de straal kijken of deze rechtstreeks bekijken met optische instrumenten. Als u de laseruitvoer met bepaalde optische instrumenten bekijkt (zoals bijv. een oogloep, vergrootglas of microscoop) binnen een afstand van 100 mm kan dit gevaar voor uw ogen opleveren.

**Varoitus** Päättämättömän kuitukaapelin tai -liittimen päästä voi tulla näkymätöntä lasersäteilyä. Älä tuijota sädettä tai katso sitä suoraan optisilla välineillä. Lasersäteen katsominen tietyillä optisilla välineillä (esim. suurennuslasilla tai mikroskoopilla) 10 cm:n päästä tai sitä lähempää voi olla vaarallista silmille.

**Attention** Des émissions de radiations laser invisibles peuvent se produire à l'extrémité d'un câble en fibre ou d'un raccord sans terminaison. Ne pas fixer du regard le rayon ou l'observer directement avec des instruments optiques. L'observation du laser à l'aide certains instruments optiques (loupes et microscopes) à une distance inférieure à 100 mm peut poser des risques pour les yeux.

**Warnung** Eine unsichtbare Laserstrahlung kann vom Ende des nicht angeschlossenen Glasfaserkabels oder Steckers ausgestrahlt werden. Nicht in den Laserstrahl schauen oder diesen mit einem optischen Instrument direkt ansehen. Ein Betrachten des Laserstrahls mit bestimmten optischen Instrumenten, wie z.B. Augenlupen, Vergrößerungsgläsern und Mikroskopen innerhalb eines Abstands von 100 mm kann für das Auge gefährlich sein.

**Avvertenza** L'estremità del connettore o del cavo ottico senza terminazione può emettere radiazioni laser invisibili. Non fissare il raggio od osservarlo in modo diretto con strumenti ottici. L'osservazione del fascio laser con determinati strumenti ottici (come lupette, lenti di ingrandimento o microscopi) entro una distanza di 100 mm può provocare danni agli occhi.

**Advarsel** Usynlig laserstråling kan emitte fra enden av den ikke-terminerte fiberkabelen eller koblingen. Ikke se inn i strålen og se heller ikke direkte på strålen med optiske instrumenter. Observering av laserutgang med visse optiske instrumenter (for eksempel øyelupe, forstørrelsesglass eller mikroskoper) innenfor en avstand på 100 mm kan være farlig for øynene.

**Aviso** Radiação laser invisível pode ser emitida pela ponta de um conector ou cabo de fibra não terminado. Não olhe fixa ou diretamente para o feixe ou com instrumentos ópticos. Visualizar a emissão do laser com certos instrumentos ópticos (por exemplo, lupas, lentes de aumento ou microscópios) a uma distância de 100 mm pode causar riscos à visão.

**¡Atención!** El extremo de un cable o conector de fibra sin terminación puede emitir radiación láser invisible. No se acerque al radio de acción ni lo mire directamente con instrumentos ópticos. La exposición del ojo a una salida de láser con determinados instrumentos ópticos (por ejemplo, lupas y microscopios) a una distancia de 100 mm puede comportar lesiones oculares.

**Warning!** Osynlig laserstråling kan komma från änden på en oavslutad fiberkabel eller -anslutning. Titta inte rakt in i strålen eller direkt på den med optiska instrument. Att titta på laserstrålen med vissa optiska instrument (t.ex. lupper, förstoringsglas och mikroskop) från ett avstånd på 100 mm kan skada ögonen.

## RELATED DOCUMENTATION

*General Safety Guidelines and Warnings*

*Radiation from Open Port Apertures Warning*

*Installation Instructions Warning*

*Grounded Equipment Warning*

# Maintenance and Operational Safety Guidelines and Warnings

## IN THIS SECTION

- Battery Handling Warning | 195
- Jewelry Removal Warning | 196
- Lightning Activity Warning | 198
- Operating Temperature Warning | 198
- Product Disposal Warning | 200

While performing the maintenance activities for devices, observe the following guidelines and warnings:

## Battery Handling Warning



**WARNING:** Replacing a battery incorrectly might result in an explosion. Replace a battery only with the same or equivalent type recommended by the manufacturer. Dispose of used batteries according to the manufacturer's instructions.

**Waarschuwing** Er is ontploffingsgevaar als de batterij verkeerd vervangen wordt. Vervang de batterij slechts met hetzelfde of een equivalent type dat door de fabrikant aanbevolen is. Gebruikte batterijen dienen overeenkomstig fabrieksvoorschriften weggeworpen te worden.

**Varoitus** Räjähdyksen vaara, jos akku on vaihdettu väärään akkuun. Käytä vaihtamiseen ainoastaan saman- tai vastaaventyyppistä akkua, joka on valmistajan suosittama. Hävitä käytetyt akut valmistajan ohjeiden mukaan.

**Avertissement** Danger d'explosion si la pile n'est pas remplacée correctement. Ne la remplacer que par une pile de type semblable ou équivalent, recommandée par le fabricant. Jeter les piles usagées conformément aux instructions du fabricant.

**Warnung** Bei Einsetzen einer falschen Batterie besteht Explosionsgefahr. Ersetzen Sie die Batterie nur durch den gleichen oder vom Hersteller empfohlenen Batterietyp. Entsorgen Sie die benutzten Batterien nach den Anweisungen des Herstellers.

**Advarsel** Det kan være fare for eksplosjon hvis batteriet skiftes på feil måte. Skift kun med samme eller tilsvarende type som er anbefalt av produsenten. Kasser brukte batterier i henhold til produsentens instruksjoner.

**Avvertenza** Pericolo di esplosione se la batteria non è installata correttamente. Sostituire solo con una di tipo uguale o equivalente, consigliata dal produttore. Eliminare le batterie usate secondo le istruzioni del produttore.

**Aviso** Existe perigo de explosão se a bateria for substituída incorrectamente. Substitua a bateria por uma bateria igual ou de um tipo equivalente recomendado pelo fabricante. Destrua as baterias usadas conforme as instruções do fabricante.

**¡Atención!** Existe peligro de explosión si la batería se reemplaza de manera incorrecta. Reemplazar la batería EXclusivamente con el mismo tipo o el equivalente recomendado por el fabricante. Desechar las baterías gastadas según las instrucciones del fabricante.

**Varning!** Explosionsfara vid felaktigt batteribyte. Ersätt endast batteriet med samma batterityp som rekommenderas av tillverkaren eller motsvarande. Följ tillverkarens anvisningar vid kassering av använda batterier.

## Jewelry Removal Warning



**WARNING:** Before working on equipment that is connected to power lines, remove jewelry, including rings, necklaces, and watches. Metal objects heat up when connected to power and ground and can cause serious burns or can be welded to the terminals.

**Waarschuwing** Alvorens aan apparatuur te werken die met elektrische leidingen is verbonden, sieraden (inclusief ringen, kettingen en horloges) verwijderen. Metalen voorwerpen worden warm wanneer ze met stroom en aarde zijn verbonden, en kunnen ernstige brandwonden veroorzaken of het metalen voorwerp aan de aansluitklemmen lassen.

**Varoitus** Ennen kuin työskentelet voimavirtajohtoihin kytkettyjen laitteiden parissa, ota pois kaikki korut (sormukset, kaulakorut ja kellot mukaan lukien). Metalliesineet

kuumenevat, kun ne ovat yhteydessä sähkövirran ja maan kanssa, ja ne voivat aiheuttaa vakavia palovammoja tai hitsata metalliesineet kiinni liitännänapoihin.

**Avvertissement** Avant d'accéder à cet équipement connecté aux lignes électriques, ôter tout bijou (anneaux, colliers et montres compris). Lorsqu'ils sont branchés à l'alimentation et reliés à la terre, les objets métalliques chauffent, ce qui peut provoquer des blessures graves ou souder l'objet métallique aux bornes.

**Warnung** Vor der Arbeit an Geräten, die an das Netz angeschlossen sind, jeglichen Schmuck (einschließlich Ringe, Ketten und Uhren) abnehmen. Metallgegenstände erhitzen sich, wenn sie an das Netz und die Erde angeschlossen werden, und können schwere Verbrennungen verursachen oder an die Anschlußklemmen angeschweißt werden.

**Avvertenza** Prima di intervenire su apparecchiature collegate alle linee di alimentazione, togliersi qualsiasi monile (inclusi anelli, collane, braccialetti ed orologi). Gli oggetti metallici si riscaldano quando sono collegati tra punti di alimentazione e massa: possono causare ustioni gravi oppure il metallo può saldarsi ai terminali.

**Advarsel** Fjern alle smykker (inkludert ringer, halskjeder og klokker) før du skal arbeide på utstyr som er koblet til kraftledninger. Metallgjenstander som er koblet til kraftledninger og jord blir svært varme og kan forårsake alvorlige brannskader eller smelte fast til polene.

**Aviso** Antes de trabalhar em equipamento que esteja ligado a linhas de corrente, retire todas as jóias que estiver a usar (incluindo anéis, fios e relógios). Os objectos metálicos aquecerão em contacto com a corrente e em contacto com a ligação à terra, podendo causar queimaduras graves ou ficarem soldados aos terminais.

**¡Atención!** Antes de operar sobre equipos conectados a líneas de alimentación, quitarse las joyas (incluidos anillos, collares y relojes). Los objetos de metal se calientan cuando se conectan a la alimentación y a tierra, lo que puede ocasionar quemaduras graves o que los objetos metálicos queden soldados a los bornes.

**Varning!** Tag av alla smycken (inklusive ringar, halsband och armbandsur) innan du arbetar på utrustning som är kopplad till kraftledningar. Metallobjekt hettas upp när de kopplas ihop med ström och jord och kan förorsaka allvarliga brännskador; metallobjekt kan också sammansvetsas med kontakterna.

## Lightning Activity Warning



**WARNING:** Do not work on the system or connect or disconnect cables during periods of lightning activity.

**Waarschuwing** Tijdens onweer dat gepaard gaat met bliksem, dient u niet aan het systeem te werken of kabels aan te sluiten of te ontkoppelen.

**Varoitus** Älä työskentele järjestelmän parissa äläkä yhdistä tai irrota kaapeleita ukkosilmalla.

**Avertissement** Ne pas travailler sur le système ni brancher ou débrancher les câbles pendant un orage.

**Warnung** Arbeiten Sie nicht am System und schließen Sie keine Kabel an bzw. trennen Sie keine ab, wenn es gewittert.

**Avvertenza** Non lavorare sul sistema o collegare oppure scollegare i cavi durante un temporale con fulmini.

**Advarsel** Utfør aldri arbeid på systemet, eller koble kabler til eller fra systemet når det tordner eller lyner.

**Aviso** Não trabalhe no sistema ou ligue e desligue cabos durante períodos de mau tempo (trovoada).

**¡Atención!** No operar el sistema ni conectar o desconectar cables durante el transcurso de descargas eléctricas en la atmósfera.

**Warning!** Vid åska skall du aldrig utföra arbete på systemet eller ansluta eller koppla loss kablar.

## Operating Temperature Warning



**WARNING:** To prevent the device from overheating, do not operate it in an area that exceeds the maximum recommended ambient temperature. To prevent airflow restriction, allow at least 6 in. (15.2 cm) of clearance around the ventilation openings.

**Waarschuwing** Om te voorkomen dat welke switch van de Juniper Networks router dan ook oververhit raakt, dient u deze niet te bedienen op een plaats waar de maximale aanbevolen omgevingstemperatuur van 40° C wordt overschreden. Om te voorkomen

dat de luchtstroom wordt beperkt, dient er minstens 15,2 cm speling rond de ventilatieopeningen te zijn.

**Varoitus** Ettei Juniper Networks switch-sarjan reititin ylikuumentuisi, sitä ei saa käyttää tilassa, jonka lämpötila ylittää korkeimman suositellun ympäristölämpötilan 40° C. Ettei ilmanvaihto estyisi, tuuletusaukkojen ympärille on jätettävä ainakin 15,2 cm tilaa.

**Avertissement** Pour éviter toute surchauffe des routeurs de la gamme Juniper Networks switch, ne l'utilisez pas dans une zone où la température ambiante est supérieure à 40° C. Pour permettre un flot d'air constant, dégagez un espace d'au moins 15,2 cm autour des ouvertures de ventilations.

**Warnung** Um einen Router der switch vor Überhitzung zu schützen, darf dieser nicht in einer Gegend betrieben werden, in der die Umgebungstemperatur das empfohlene Maximum von 40° C überschreitet. Um Lüftungsverschluß zu verhindern, achten Sie darauf, daß mindestens 15,2 cm lichter Raum um die Lüftungsöffnungen herum frei bleibt.

**Avvertenza** Per evitare il surriscaldamento dei switch, non adoperateli in un locale che ecceda la temperatura ambientale massima di 40° C. Per evitare che la circolazione dell'aria sia impedita, lasciate uno spazio di almeno 15.2 cm di fronte alle aperture delle ventole.

**Advarsel** Unngå overoppheting av eventuelle rutere i Juniper Networks switch Disse skal ikke brukes på steder der den anbefalte maksimale omgivelsestemperaturen overstiger 40° C (104° F). Sørg for at klaringen rundt lufteåpningene er minst 15,2 cm (6 tommer) for å forhindre nedsatt luftsirkulasjon.

**Aviso** Para evitar o sobreaquecimento do encaminhador Juniper Networks switch, não utilize este equipamento numa área que exceda a temperatura máxima recomendada de 40° C. Para evitar a restrição à circulação de ar, deixe pelo menos um espaço de 15,2 cm à volta das aberturas de ventilação.

**¡Atención!** Para impedir que un encaminador de la serie Juniper Networks switch se recaliente, no lo haga funcionar en un área en la que se supere la temperatura ambiente máxima recomendada de 40° C. Para impedir la restricción de la entrada de aire, deje un espacio mínimo de 15,2 cm alrededor de las aperturas para ventilación.

**Varning!** Förhindra att en Juniper Networks switch överhettas genom att inte använda den i ett område där den maximalt rekommenderade omgivningstemperaturen på 40° C överskrids. Förhindra att luftcirkulationen inskränks genom att se till att det finns fritt utrymme på minst 15,2 cm omkring ventilationsöppningarna.



## Product Disposal Warning



**WARNING:** Disposal of this device must be handled according to all national laws and regulations.

**Waarschuwing** Dit produkt dient volgens alle landelijke wetten en voorschriften te worden afgedankt.

**Varoitus** Tämän tuotteen lopullisesta hävittämisestä tulee huolehtia kaikkia valtakunnallisia lakeja ja säännöksiä noudattaen.

**Avertissement** La mise au rebut définitive de ce produit doit être effectuée conformément à toutes les lois et réglementations en vigueur.

**Warnung** Dieses Produkt muß den geltenden Gesetzen und Vorschriften entsprechend entsorgt werden.

**Avvertenza** L'eliminazione finale di questo prodotto deve essere eseguita osservando le normative italiane vigenti in materia

**Advarsel** Endelig disponering av dette produktet må skje i henhold til nasjonale lover og forskrifter.

**Aviso** A descartagem final deste produto deverá ser efectuada de acordo com os regulamentos e a legislação nacional.

**¡Atención!** El desecho final de este producto debe realizarse según todas las leyes y regulaciones nacionales

**Warning!** Slutlig kassering av denna produkt bör skötas i enlighet med landets alla lagar och föreskrifter.

## General Electrical Safety Guidelines and Warnings



**WARNING:** Certain ports on the device are designed for use as intrabuilding (within-the-building) interfaces only (Type 2 or Type 4 ports as described in *GR-1089-CORE*) and require isolation from the exposed outside plant (OSP) cabling. To comply with NEBS (Network Equipment-Building System) requirements and protect against lightning surges and commercial power disturbances, the intrabuilding ports *must not* be metallically connected to interfaces that connect to the OSP or its wiring. The

intrabuilding ports on the device are suitable for connection to intrabuilding or unexposed wiring or cabling only. The addition of primary protectors is not sufficient protection for connecting these interfaces metalically to OSP wiring.

**Avertissement** Certains ports de l'appareil sont destinés à un usage en intérieur uniquement (ports Type 2 ou Type 4 tels que décrits dans le document *GR-1089-CORE*) et doivent être isolés du câblage de l'installation extérieure exposée. Pour respecter les exigences NEBS et assurer une protection contre la foudre et les perturbations de tension secteur, les ports pour intérieur *ne doivent pas* être raccordés physiquement aux interfaces prévues pour la connexion à l'installation extérieure ou à son câblage. Les ports pour intérieur de l'appareil sont réservés au raccordement de câbles pour intérieur ou non exposés uniquement. L'ajout de protections ne constitue pas une précaution suffisante pour raccorder physiquement ces interfaces au câblage de l'installation extérieure.



**CAUTION:** Before removing or installing components of a device, connect an electrostatic discharge (ESD) grounding strap to an ESD point and wrap and fasten the other end of the strap around your bare wrist. Failure to use an ESD grounding strap could result in damage to the device.

**Attention** Avant de retirer ou d'installer des composants d'un appareil, raccordez un bracelet antistatique à un point de décharge électrostatique et fixez le bracelet à votre poignet nu. L'absence de port d'un bracelet antistatique pourrait provoquer des dégâts sur l'appareil.

- Install the device in compliance with the following local, national, and international electrical codes:
  - United States—National Fire Protection Association (NFPA 70), United States National Electrical Code.
  - Other countries—International Electromechanical Commission (IEC) 60364, Part 1 through Part 7.
  - Evaluated to the TN power system.
  - Canada—Canadian Electrical Code, Part 1, CSA C22.1.
  - Suitable for installation in Information Technology Rooms in accordance with Article 645 of the National Electrical Code and NFPA 75.
 

Peut être installé dans des salles de matériel de traitement de l'information conformément à l'article 645 du National Electrical Code et à la NFPA 75.
- Locate the emergency power-off switch for the room in which you are working so that if an electrical accident occurs, you can quickly turn off the power.

- Make sure that you clean grounding surface and give them a bright finish before making grounding connections.
- Do not work alone if potentially hazardous conditions exist anywhere in your workspace.
- Never assume that power is disconnected from a circuit. Always check the circuit before starting to work.
- Carefully look for possible hazards in your work area, such as moist floors, ungrounded power extension cords, and missing safety grounds.
- Operate the device within marked electrical ratings and product usage instructions.
- To ensure that the device and peripheral equipment function safely and correctly, use the cables and connectors specified for the attached peripheral equipment, and make certain they are in good condition.

You can remove and replace many device components without powering off or disconnecting power to the device, as detailed elsewhere in the hardware documentation for this device. Never install equipment that appears to be damaged.

## Action to Take After an Electrical Accident

If an electrical accident results in an injury, take the following actions in this order:

1. Use caution. Be aware of potentially hazardous conditions that could cause further injury.
2. Disconnect power from the device.
3. If possible, send another person to get medical aid. Otherwise, assess the condition of the victim, and then call for help.

## Prevention of Electrostatic Discharge Damage

Device components that are shipped in antistatic bags are sensitive to damage from static electricity. Some components can be impaired by voltages as low as 30 V. You can easily generate potentially damaging static voltages whenever you handle plastic or foam packing material or if you move components across plastic or carpets. Observe the following guidelines to minimize the potential for electrostatic discharge (ESD) damage, which can cause intermittent or complete component failures:

- Always use an ESD wrist strap when you are handling components that are subject to ESD damage, and make sure that it is in direct contact with your skin.

If a grounding strap is not available, hold the component in its antistatic bag (see [Figure 79 on page 204](#)) in one hand and touch the exposed, bare metal of the device with the other hand immediately before inserting the component into the device.



**WARNING:** For safety, periodically check the resistance value of the ESD grounding strap. The measurement must be in the range 1 through 10 Mohms.

**Avertissement** Par mesure de sécurité, vérifiez régulièrement la résistance du bracelet antistatique. Cette valeur doit être comprise entre 1 et 10 mégohms (Mohms).

- When handling any component that is subject to ESD damage and that is removed from the device, make sure the equipment end of your ESD wrist strap is attached to the ESD point on the chassis.

If no grounding strap is available, touch the exposed, bare metal of the device to ground yourself before handling the component.

- Avoid contact between the component that is subject to ESD damage and your clothing. ESD voltages emitted from clothing can damage components.
- When removing or installing a component that is subject to ESD damage, always place it component-side up on an antistatic surface, in an antistatic card rack, or in an antistatic bag (see [Figure 79 on page 204](#)). If you are returning a component, place it in an antistatic bag before packing it.

Figure 79: Placing a Component into an Antistatic Bag

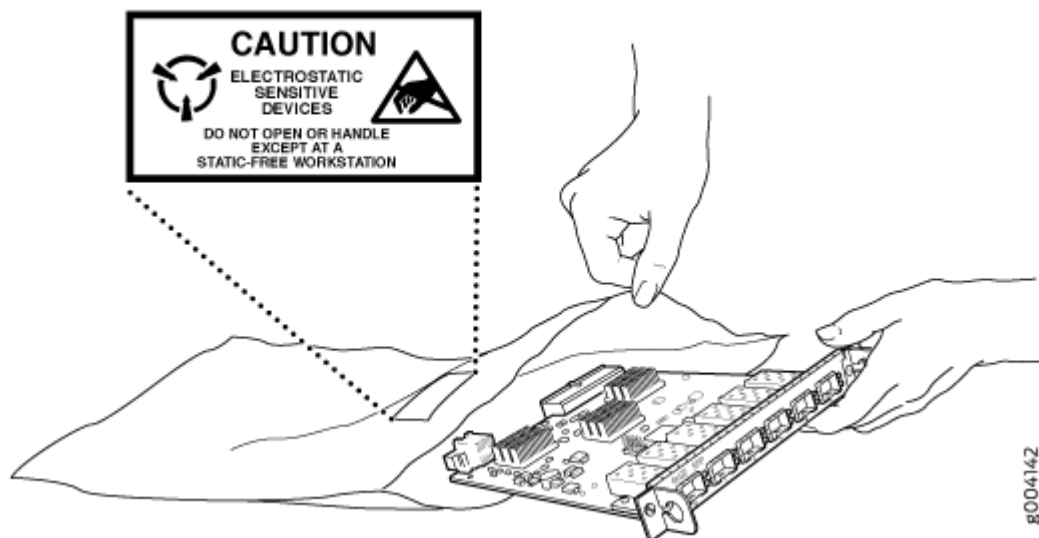

**CAUTION:** ANSI/TIA/EIA-568 cables such as Category 5e and Category 6 can get electrostatically charged. To dissipate this charge, always ground the cables to a suitable and safe earth ground before connecting them to the system.

**Attention** Les câbles ANSI/TIA/EIA-568, par exemple Cat 5e et Cat 6, peuvent emmagasiner des charges électrostatiques. Pour évacuer ces charges, reliez toujours les câbles à une prise de terre adaptée avant de les raccorder au système.

## AC Power Electrical Safety Guidelines

The following electrical safety guidelines apply to AC-powered devices:

- Note the following warnings printed on the device:

**“CAUTION:** THIS UNIT HAS MORE THAN ONE POWER SUPPLY CORD. DISCONNECT ALL POWER SUPPLY CORDS BEFORE SERVICING TO AVOID ELECTRIC SHOCK.”

**“ATTENTION:** CET APPAREIL COMPORTE PLUS D'UN CORDON D'ALIMENTATION. AFIN DE PRÉVENIR LES CHOCS ÉLECTRIQUES, DÉBRANCHER TOUT CORDON D'ALIMENTATION AVANT DE FAIRE LE DÉPANNAGE.”

- AC-powered devices are shipped with a three-wire electrical cord with a grounding-type plug that fits only a grounding-type power outlet. Do not circumvent this safety feature. Equipment grounding must comply with local and national electrical codes.
- You must provide an external certified circuit breaker (2-pole circuit breaker or 4-pole circuit breaker based on your device) rated minimum 20 A in the building installation.
- The power cord serves as the main disconnecting device for the AC-powered device. The socket outlet must be near the AC-powered device and be easily accessible.
- For devices that have more than one power supply connection, you must ensure that all power connections are fully disconnected so that power to the device is completely removed to prevent electric shock. To disconnect power, unplug all power cords (one for each power supply).

#### Power Cable Warning (Japanese)

**WARNING:** The attached power cable is only for this product. Do not use the cable for another product.

**注意**

附属の電源コードセットはこの製品専用です。  
他の電気機器には使用しないでください。

0017283

## AC Power Disconnection Warning



**WARNING:** Before working on the device or near power supplies, unplug all the power cords from an AC-powered device.

**Waarschuwing** Voordat u aan een frame of in de nabijheid van voedingen werkt, dient u bij wisselstroom toestellen de stekker van het netsnoer uit het stopcontact te halen.

**Varoitus** Kytke irti vaihtovirtalaitteiden virtajohto, ennen kuin teet mitään asennuspohjalle tai työskentelet virtalähteiden läheisyydessä.

**Avertissement** Avant de travailler sur un châssis ou à proximité d'une alimentation électrique, débrancher le cordon d'alimentation des unités en courant alternatif.

**Warnung** Bevor Sie an einem Chassis oder in der Nähe von Netzgeräten arbeiten, ziehen Sie bei Wechselstromeinheiten das Netzkabel ab bzw.

**Avvertenza** Prima di lavorare su un telaio o intorno ad alimentatori, scollegare il cavo di alimentazione sulle unità CA.

**Advarsel** Før det utføres arbeid på kabinettet eller det arbeides i nærheten av strømforsyningsenheter, skal strømledningen trekkes ut på vekselstrømsenheter.

**Aviso** Antes de trabalhar num chassis, ou antes de trabalhar perto de unidades de fornecimento de energia, desligue o cabo de alimentação nas unidades de corrente alternada.

**¡Atención!** Antes de manipular el chasis de un equipo o trabajar cerca de una fuente de alimentación, desenchufar el cable de alimentación en los equipos de corriente alterna (CA).

**Varning!** Innan du arbetar med ett chassi eller nära strömförsörjningsenheter skall du för växelströmsenheter dra ur nätsladden.

## DC Power Electrical Safety Guidelines

- A DC-powered device is equipped with a DC terminal block that is rated for the power requirements of a maximally configured device.
- For permanently connected equipment, a readily accessible disconnect device shall be incorporated external to the equipment.
- For pluggable equipment, the socket-outlet shall be installed near the equipment and shall be easily accessible.
- Be sure to connect the ground wire or conduit to a solid central office earth ground.
- A closed loop ring is recommended for terminating the ground conductor at the ground stud.
- Run two wires from the circuit breaker box to a source of 48 VDC.
- A DC-powered device that is equipped with a DC terminal block is intended only for installation in a restricted-access location. In the United States, a restricted-access area is one in accordance with Articles 110-16, 110-17, and 110-18 of the National Electrical Code ANSI/NFPA 70.

**NOTE:** Primary overcurrent protection is provided by the building circuit breaker. This breaker must protect against excess currents, short circuits, and earth grounding faults in accordance with NEC ANSI/NFPA 70.

- Ensure that the polarity of the DC input wiring is correct. Under certain conditions, connections with reversed polarity might trip the primary circuit breaker or damage the equipment.
- The marked input voltage of -48 VDC for a DC-powered device is the nominal voltage associated with the battery circuit, and any higher voltages are only to be associated with float voltages for the charging function.
- Because the device is a positive ground system, you must connect the positive lead to the terminal labeled **RTN**, the negative lead to the terminal labeled -48 VDC, and the earth ground to the device grounding points.

## DC Power Disconnection Warning



**WARNING:** Before performing any of the DC power procedures, ensure that power is removed from the DC circuit. To ensure that all power is off, locate the circuit breaker on the panel board that services the DC circuit, switch the circuit breaker to the OFF position, and tape the device handle of the circuit breaker in the OFF position.

**Waarschuwing** Voordat u een van de onderstaande procedures uitvoert, dient u te controleren of de stroom naar het gelijkstroom circuit uitgeschakeld is. Om u ervan te verzekeren dat alle stroom UIT is geschakeld, kiest u op het schakelbord de stroomverbreker die het gelijkstroom circuit bedient, draait de stroomverbreker naar de UIT positie en plakt de schakelaarhendel van de stroomverbreker met plakband in de UIT positie vast.

**Varoitus** Varmista, että tasavirtapiirissä ei ole virtaa ennen seuraavien toimenpiteiden suorittamista. Varmistaaksesi, että virta on KATKAISTU täysin, paikanna tasavirrasta huolehtivassa kojetaulussa sijaitseva suojakytkin, käännä suojakytkin KATKAISTU-asentoon ja teippaa suojakytkimen varsi niin, että se pysyy KATKAISTU-asennossa.

**Avertissement** Avant de pratiquer l'une quelconque des procédures ci-dessous, vérifier que le circuit en courant continu n'est plus sous tension. Pour en être sûr, localiser le disjoncteur situé sur le panneau de service du circuit en courant continu, placer le



disjoncteur en position fermée (OFF) et, à l'aide d'un ruban adhésif, bloquer la poignée du disjoncteur en position OFF.

**Warnung** Vor Ausführung der folgenden Vorgänge ist sicherzustellen, daß die Gleichstromschaltung keinen Strom erhält. Um sicherzustellen, daß sämtlicher Strom abgestellt ist, machen Sie auf der Schalttafel den Unterbrecher für die Gleichstromschaltung ausfindig, stellen Sie den Unterbrecher auf AUS, und kleben Sie den Schaltergriff des Unterbrechers mit Klebeband in der AUS-Stellung fest.

**Avvertenza** Prima di svolgere una qualsiasi delle procedure seguenti, verificare che il circuito CC non sia alimentato. Per verificare che tutta l'alimentazione sia scollegata (OFF), individuare l'interruttore automatico sul quadro strumenti che alimenta il circuito CC, mettere l'interruttore in posizione OFF e fissarlo con nastro adesivo in tale posizione.

**Advarsel** Før noen av disse prosedyrene utføres, kontroller at strømmen er frakoblet likestrømkretsen. Sørg for at all strøm er slått AV. Dette gjøres ved å lokalisere strømbryteren på brytertavlen som betjener likestrømkretsen, slå strømbryteren AV og teipe bryterhåndtaket på strømbryteren i AV-stilling.

**Aviso** Antes de executar um dos seguintes procedimentos, certifique-se que desligou a fonte de alimentação de energia do circuito de corrente contínua. Para se assegurar que toda a corrente foi DESLIGADA, localize o disjuntor no painel que serve o circuito de corrente contínua e coloque-o na posição OFF (Desligado), segurando nessa posição a manivela do interruptor do disjuntor com fita isoladora.

**¡Atención!** Antes de proceder con los siguientes pasos, comprobar que la alimentación del circuito de corriente continua (CC) esté cortada (OFF). Para asegurarse de que toda la alimentación esté cortada (OFF), localizar el interruptor automático en el panel que alimenta al circuito de corriente continua, cambiar el interruptor automático a la posición de Apagado (OFF), y sujetar con cinta la palanca del interruptor automático en posición de Apagado (OFF).

**Varning!** Innan du utför någon av följande procedurer måste du kontrollera att strömförsörjningen till likströmskretsen är bruten. Kontrollera att all strömförsörjning är BRUTEN genom att slå AV det överspänningsskydd som skyddar likströmskretsen och tejpa fast överspänningsskyddets omkopplare i FRÅN-läget.

## DC Power Grounding Requirements and Warning

An insulated grounding conductor that is identical in size to the grounded and ungrounded branch circuit supply conductors but is identifiable by green and yellow stripes is installed as part of the branch circuit that supplies the device. The grounding conductor is a separately derived system at the supply transformer or motor generator set.



**WARNING:** When you install the device, the ground connection must always be made first and disconnected last.

**Waarschuwing** Bij de installatie van het toestel moet de aardverbinding altijd het eerste worden gemaakt en het laatste worden losgemaakt.

**Varoitus** Laitetta asennettaessa on maahan yhdistäminen aina tehtävä ensiksi ja maadoituksen irti kytkeminen viimeiseksi.

**Avertissement** Lors de l'installation de l'appareil, la mise à la terre doit toujours être connectée en premier et déconnectée en dernier.

**Warnung** Der Erdanschluß muß bei der Installation der Einheit immer zuerst hergestellt und zuletzt abgetrennt werden.

**Avvertenza** In fase di installazione dell'unità, eseguire sempre per primo il collegamento a massa e disconnetterlo per ultimo.

**Advarsel** Når enheten installeres, må jordledningen alltid tilkobles først og frakobles sist.

**Aviso** Ao instalar a unidade, a ligação à terra deverá ser sempre a primeira a ser ligada, e a última a ser desligada.

**¡Atención!** Al instalar el equipo, conectar la tierra la primera y desconectarla la última.

**Warning!** Vid installation av enheten måste jordledningen alltid anslutas först och kopplas bort sist.

## DC Power Wiring Sequence Warning



**WARNING:** Wire the DC power supply using the appropriate lugs. When connecting power, the proper wiring sequence is ground to ground, +RTN to +RTN, then -48 V to -

48 V. When disconnecting power, the proper wiring sequence is -48 V to -48 V, +RTN to +RTN, then ground to ground. Note that the ground wire must always be connected first and disconnected last.

**Waarschuwing** De juiste bedradingsvolgorde verbonden is aarde naar aarde, +RTN naar +RTN, en -48 V naar -48 V. De juiste bedradingsvolgorde losgemaakt is en -48 naar -48 V, +RTN naar +RTN, aarde naar aarde.

**Varoitus** Oikea yhdistettävä kytkentäjäjestys on maajohto maajohtoon, +RTN varten +RTN, -48 V varten -48 V. Oikea irrotettava kytkentäjäjestys on -48 V varten -48 V, +RTN varten +RTN, maajohto maajohtoon.

**Avertissement** Câblez l'alimentation d'alimentation CC En utilisant les crochets appropriés à l'extrémité de câblage. En reliant la puissance, l'ordre approprié de câblage est rectifié pour rectifier, +RTN à +RTN, puis -48 V à -48 V. En débranchant la puissance, l'ordre approprié de câblage est -48 V à -48 V, +RTN à +RTN, a alors rectifié pour rectifier. Notez que le fil de masse devrait toujours être relié d'abord et débranché pour la dernière fois. Notez que le fil de masse devrait toujours être relié d'abord et débranché pour la dernière fois.

**Warnung** Die Stromzufuhr ist nur mit geeigneten Ringösen an das DC Netzteil anzuschliessen. Die richtige Anschlusssequenz ist: Erdanschluss zu Erdanschluss, +RTN zu +RTN und dann -48V zu -48V. Die richtige Sequenz zum Abtrennen der Stromversorgung ist -48V zu -48V, +RTN zu +RTN und dann Erdanschluss zu Erdanschluss. Es ist zu beachten dass der Erdanschluss immer zuerst angeschlossen und als letztes abgetrennt wird.

**Avvertenza** Mostra la morsettiera dell'alimentatore CC. Cablare l'alimentatore CC usando i connettori adatti all'estremità del cablaggio, come illustrato. La corretta sequenza di cablaggio è da massa a massa, da positivo a positivo (da linea ad L) e da negativo a negativo (da neutro a N). Tenere presente che il filo di massa deve sempre venire collegato per primo e scollegato per ultimo.

**Advarsel** Riktig tilkoples tilkoplingssekvens er jord til jord, +RTN til +RTN, -48 V til -48 V. Riktig frakoples tilkoplingssekvens er -48 V til -48 V, +RTN til +RTN, jord til jord.

**Aviso** Ate con alambre la fuente de potencia cc Usando los terminales apropiados en el extremo del cableado. Al conectar potencia, la secuencia apropiada del cableado se muele para moler, +RTN a +RTN, entonces -48 V a -48 V. Al desconectar potencia, la secuencia apropiada del cableado es -48 V a -48 V, +RTN a +RTN, entonces molió para moler. Observe que el alambre de tierra se debe conectar siempre primero y desconectar por último. Observe que el alambre de tierra se debe conectar siempre primero y desconectar por último.

**¡Atención!** Wire a fonte de alimentação de DC Usando os talões apropriados nan Extremidade da fiação. Ao conectar a potência, a seqüência apropriada da fiação é moída para moer, +RTN a +RTN, então -48 V a -48 V. Ao desconectar a potência, a seqüência apropriada da fiação é -48 V a -48 V, +RTN a +RTN, moeu então para moer. Anote que o fio à terra deve sempre ser conectado primeiramente e desconectado por último. Anote que o fio à terra deve sempre ser conectado primeiramente e desconectado por último.

**Warning!** Korrekt kopplingssekvens ar jord till jord, +RTN till +RTN, -48 V till -48 V. Korrekt kopplas kopplingssekvens ar -48 V till -48 V, +RTN till +RTN, jord till jord.

## DC Power Wiring Terminations Warning



**WARNING:** When stranded wiring is required, use approved wiring terminations, such as closed-loop or spade-type with upturned lugs. These terminations must be the appropriate size for the wires and must clamp both the insulation and conductor.

**Waarschuwing** Wanneer geslagen bedrading vereist is, dient u bedrading te gebruiken die voorzien is van goedgekeurde aansluitingspunten, zoals het gesloten-lus type of het grijperschop type waarbij de aansluitpunten omhoog wijzen. Deze aansluitpunten dienen de juiste maat voor de draden te hebben en dienen zowel de isolatie als de geleider vast te klemmen.

**Varoitus** Jos säikeellinen johdin on tarpeen, käytä hyväksytyä johdinliitääntää, esimerkiksi suljettua silmukkaa tai kourumaista liitääntää, jossa on ylöspäin käännetyt kiinnityskorvat. Tällaisten liitääntöjen tulee olla kooltaan johtimiin sopivia ja niiden tulee puristaa yhteen sekä eristeen että johdinosan.

**Avertissement** Quand des fils torsadés sont nécessaires, utiliser des douilles terminales homologuées telles que celles à circuit fermé ou du type à plage ouverte avec cosses rebroussées. Ces douilles terminales doivent être de la taille qui convient aux fils et doivent être refermées sur la gaine isolante et sur le conducteur.

**Warnung** Wenn Litzenverdrahtung erforderlich ist, sind zugelassene Verdrahtungsabschlüsse, z.B. für einen geschlossenen Regelkreis oder gabelförmig, mit nach oben gerichteten Kabelschuhen zu verwenden. Diese Abschlüsse sollten die angemessene Größe für die Drähte haben und sowohl die Isolierung als auch den Leiter festklemmen.

**Avvertenza** Quando occorre usare trecce, usare connettori omologati, come quelli a occhio o a forcella con linguette rivolte verso l'alto. I connettori devono avere la misura adatta per il cablaggio e devono serrare sia l'isolante che il conduttore.

**Advarsel** Hvis det er nødvendig med flertrådede ledninger, brukes godkjente ledningsavslutninger, som for eksempel lukket sløyfe eller spadetype med oppoverbøyde kabelsko. Disse avslutningene skal ha riktig størrelse i forhold til ledningene, og skal klemme sammen både isolasjonen og ledaren.

**Aviso** Quando forem requeridas montagens de instalação eléctrica de cabo torcido, use terminações de cabo aprovadas, tais como, terminações de cabo em circuito fechado e planas com terminais de orelha voltados para cima. Estas terminações de cabo deverão ser do tamanho apropriado para os respectivos cabos, e deverão prender simultaneamente o isolamento e o fio condutor.

**¡Atención!** Cuando se necesite hilo trenzado, utilizar terminales para cables homologados, tales como las de tipo "bucle cerrado" o "espada", con las lengüetas de conexión vueltas hacia arriba. Estos terminales deberán ser del tamaño apropiado para los cables que se utilicen, y tendrán que sujetar tanto el aislante como el conductor.

**Varning!** När flertrådiga ledningar krävs måste godkända ledningskontakter användas, t.ex. kabelsko av sluten eller öppen typ med uppåtvänd tapp. Storleken på dessa kontakter måste vara avpassad till ledningarna och måste kunna hålla både isoleringen och ledaren fastklämda.

## Multiple Power Supplies Disconnection Warning



**WARNING:** The network device has more than one power supply connection. All connections must be removed completely to remove power from the unit completely.

**Waarschuwing** Deze eenheid heeft meer dan één stroomtoevoerverbinding; alle verbindingen moeten volledig worden verwijderd om de stroom van deze eenheid volledig te verwijderen.

**Varoitus** Tässä laitteessa on useampia virtalähdekytkentöjä. Kaikki kytkennät on irrotettava kokonaan, jotta virta poistettaisiin täysin laitteesta.

**Avertissement** Cette unité est équipée de plusieurs raccordements d'alimentation. Pour supprimer tout courant électrique de l'unité, tous les cordons d'alimentation doivent être débranchés.

**Warnung** Diese Einheit verfügt über mehr als einen Stromanschluß; um Strom gänzlich von der Einheit fernzuhalten, müssen alle Stromzufuhren abgetrennt sein.

**Avvertenza** Questa unità ha più di una connessione per alimentatore elettrico; tutte le connessioni devono essere completamente rimosse per togliere l'elettricità dall'unità.

**Advarsel** Denne enheten har mer enn én strømtilkobling. Alle tilkoblinger må kobles helt fra for å eliminere strøm fra enheten.

**Aviso** Este dispositivo possui mais do que uma conexão de fonte de alimentação de energia; para poder remover a fonte de alimentação de energia, deverão ser desconectadas todas as conexões existentes.

**¡Atención!** Esta unidad tiene más de una conexión de suministros de alimentación; para eliminar la alimentación por completo, deben desconectarse completamente todas las conexiones.

**Warning!** Denna enhet har mer än en strömförsörjningsanslutning; alla anslutningar måste vara helt avlägsnade innan strömtillförseln till enheten är fullständigt bruten.

## TN Power Warning



**WARNING:** The device is designed to work with a TN power system.

**Waarschuwing** Het apparaat is ontworpen om te functioneren met TN energiesystemen.

**Varoitus** Koje on suunniteltu toimimaan TN-sähkövoimajärjestelmien yhteydessä.

**Avertissement** Ce dispositif a été conçu pour fonctionner avec des systèmes d'alimentation TN.

**Warnung** Das Gerät ist für die Verwendung mit TN-Stromsystemen ausgelegt.

**Avvertenza** Il dispositivo è stato progettato per l'uso con sistemi di alimentazione TN.

**Advarsel** Utstyret er utfomet til bruk med TN-strømsystemer.

**Aviso** O dispositivo foi criado para operar com sistemas de corrente TN.

**¡Atención!** El equipo está diseñado para trabajar con sistemas de alimentación tipo TN.

**Varning!** Enheten är konstruerad för användning tillsammans med elkraftssystem av TN-typ.

## QFX5110 Agency Approvals

### IN THIS SECTION

- [Agency Approvals for the QFX Series | 214](#)
- [Compliance Statements for EMC Requirements for the QFX Series | 216](#)

## Agency Approvals for the QFX Series

### IN THIS SECTION

- [Compliance Statement for Argentina | 216](#)

The QFX Series complies with the following standards:

- Safety
  - CAN/CSA-C22.2 No. 60950-1 Safety of Information Technology Equipment
  - UL 62368-1 Audio/Video, Information and Communication Technology Equipment- Safety
  - IEC 62368-1: 2014 Audio/Video, Information and Communication Technology Equipment–Safety
  - IEC 60950-1: 2005/A2:2013 Information Technology Equipment -Safety (All country deviations): CB Scheme

- EN 60825-1 Safety of Laser Products - Part 1: Equipment Classification, Requirements and User's Guide
- Electromagnetic Compatibility (EMC)
  - EN 300 386 V1.6.1 (2012) Telecom Network Equipment–EMC requirements
  - EN 55024: 1998/A1:2001/A2:2003 Information Technology Equipment Immunity Characteristics
  - TEC/SD/DD/EMC-221–India EMC standard
  - EN 301 489-1 V1.92 (2011-09)–EMC and Radio spectrum Matters
  - EN 55024
  - CISPR 24
  - BSMI, Class A
  - CNS 13438
- Electromagnetic Interference (EMI)
  - FCC 47 CFR Part 15, Class A (2009) USA Radiated Emissions
  - EN 55022 Class A (2010) European Radiated Emissions
  - VCCI Class A:(2010) Japanese Emissions
  - BSMI CNS 13438 and NCC C6357 Class A Taiwan Radiated Emissions
  - AS/NZS CISPR 22:2009: Class A, Australian/New Zealand Radiated Emissions
- Immunity
  - EN 55024: 1998/A1:2001/A2:2003 Information Technology Equipment Immunity Characteristics
  - EN-61000-3-2 (2006) Power Line Harmonics
  - EN-61000-3-3 (2013) Power Line Voltage Fluctuations
  - EN-61000-4-2 (2009) Electrostatic Discharge
  - EN-61000-4-3 (2007) Radiated Immunity
  - EN-61000-4-4 (2012) Electrical Fast Transients
  - EN-61000-4-5 (2006) Surge
  - EN-61000-4-6 (2009) Immunity to Conducted Disturbances



- EN-61000-4-11 (2004) Voltage Dips and Sags

## Compliance Statement for Argentina

EQUIPO DE USO IDÓNEO.

## Compliance Statements for EMC Requirements for the QFX Series

### IN THIS SECTION

- [Canada | 216](#)
- [European Community | 217](#)
- [Israel | 217](#)
- [Japan | 217](#)
- [Korea | 218](#)
- [Taiwan | 218](#)
- [United States | 218](#)
- [Nonregulatory Environmental Standards | 219](#)

This topic describes the EMC requirements for the QFX Series.

### Canada

This Class A digital apparatus complies with Canadian ICES-003.

Cet appareil numérique de la classe A est conforme à la norme NMB-003 du Canada.

The Industry Canada label identifies certified equipment. This certification means that the equipment meets certain telecommunications network protective, operational, and safety requirements. Industry Canada does not guarantee the equipment will operate to the users' satisfaction.

Before installing this equipment, users should ensure that it is permissible to connect the equipment to the facilities of the local telecommunications company. The equipment must also be installed using an acceptable method of connection. In some cases, the inside wiring associated with a single line individual service may be extended by means of a certified connector assembly. The customer should be

aware that compliance with the above conditions may not prevent degradation of service in some situations.

Repairs to certified equipment should be made by an authorized Canadian maintenance facility designated by the supplier. Any repairs or alterations made by the user to this equipment, or equipment malfunctions, may give the telecommunications company cause to request the user to disconnect the equipment.



**CAUTION:** Users should not attempt to make electrical ground connections by themselves, but should contact the appropriate inspection authority or an electrician, as appropriate.

Users should ensure for their own protection that the electrical ground connections of the power utility, telephone lines, and internal metallic water pipe system, if present, are connected together. This precaution may be particularly important in rural areas.

## European Community

This is a Class A product. In a domestic environment this product may cause radio interference in which case the user may be required to take adequate measures.

## Israel

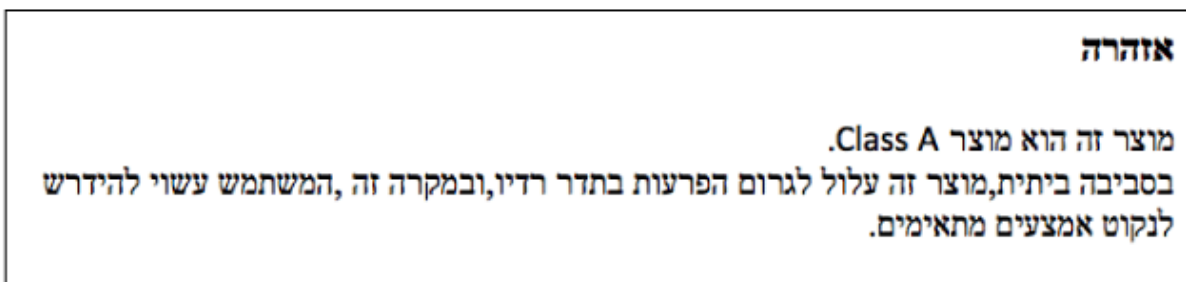

Translation from Hebrew–Warning: This product is Class A. In residential environments, the product may cause radio interference, and in such a situation, the user may be required to take adequate measures.

## Japan

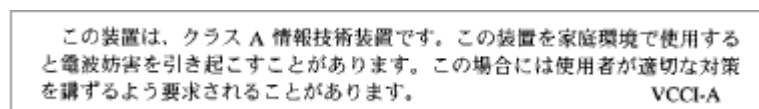

The preceding translates as follows:

This is a Class A product. In a domestic environment this product may cause radio interference in which case the user may be required to take adequate measures.

VCCI-A

## Korea

이 기기는 업무용(A급) 전자파적합기기로서 판매자 또는 사용자는 이 점을 주의하시기 바라며, 가정외의 지역에서 사용하는 것을 목적으로 합니다.

Korean Class A Warning

9040913

The preceding translates as follows:

This equipment is Industrial (Class A) electromagnetic wave suitability equipment and seller or user should take notice of it, and this equipment is to be used in the places except for home.

## Taiwan

警告使用者：  
這是甲類的資訊產品，在居住的環境中使用時，可能會造成射頻干擾，在這種情況下，使用者會被要求採取某些適當的對策。

Chinese Class A warning

060001

The preceding translates as follows:

This is Class A product. In a domestic environment this product may cause radio interference in which case the user may be required to take adequate measures.

## United States

The QFX Series device has been tested and found to comply with the limits for a Class A digital device, pursuant to Part 15 of the FCC Rules. These limits are designed to provide reasonable protection against harmful interference when the equipment is operated in a commercial environment. This equipment

generates, uses, and can radiate radio frequency energy and, if not installed and used in accordance with the instruction manual, may cause harmful interference to radio communications. Operation of this equipment in a residential area is likely to cause harmful interference in which case the user will be required to correct the interference at his own expense.

## Nonregulatory Environmental Standards

These QFX Series product SKUs are Network Equipment Building System (NEBS) compliant:

- QFX3008-I
- QFX3600-I
- QFX3600
- QFX3500
- QFX5100
- QFX5110
- QFX5200-32C
- QFX10002-36Q and QFX10002-72Q
- QFX10008
- QFX10016

Those device product SKUs meet the following NEBS compliance standards:

- SR-3580 NEBS Criteria Levels (Level 3 Compliance)
- GR-1089-CORE, Issue 6: EMC and Electrical Safety—Generic Criteria for Network Telecommunications Equipment
  - The equipment is suitable for installation in locations where the National Electrical Code (NEC) applies.
  - The battery return connection is to be treated as an Isolated DC return (DC-I), as defined in GR-1089-CORE.
- GR-63-CORE: NEBS, Physical Protection
  - The equipment is suitable for installation as part of the Common Bonding Network (CBN).
  - The equipment is suitable for installation in a central office (CO).

**SEE ALSO**

| *Agency Approvals for the QFX Series*