

SRX4100 Firewall Hardware Guide

Published
2024-07-04

Juniper Networks, Inc.
1133 Innovation Way
Sunnyvale, California 94089
USA
408-745-2000
www.juniper.net

Juniper Networks, the Juniper Networks logo, Juniper, and Junos are registered trademarks of Juniper Networks, Inc. in the United States and other countries. All other trademarks, service marks, registered marks, or registered service marks are the property of their respective owners.

Juniper Networks assumes no responsibility for any inaccuracies in this document. Juniper Networks reserves the right to change, modify, transfer, or otherwise revise this publication without notice.

SRX4100 Firewall Hardware Guide

Copyright © 2024 Juniper Networks, Inc. All rights reserved.

The information in this document is current as of the date on the title page.

YEAR 2000 NOTICE

Juniper Networks hardware and software products are Year 2000 compliant. Junos OS has no known time-related limitations through the year 2038. However, the NTP application is known to have some difficulty in the year 2036.

END USER LICENSE AGREEMENT

The Juniper Networks product that is the subject of this technical documentation consists of (or is intended for use with) Juniper Networks software. Use of such software is subject to the terms and conditions of the End User License Agreement ("EULA") posted at <https://support.juniper.net/support/eula/>. By downloading, installing or using such software, you agree to the terms and conditions of that EULA.

Table of Contents

[About This Guide | vii](#)

1

[Fast Track: Initial Installation](#)

[Fast Track to Rack Installation and Power | 2](#)

[Install the SRX4100 in a Rack | 2](#)

[Connect to Power | 3](#)

[Onboard and Configure SRX4100 | 5](#)

2

[Overview](#)

[SRX4100 Firewall Overview | 8](#)

[SRX4100 Firewall Overview | 8](#)

[Field-Replaceable Units in SRX4100 Services Gateways | 9](#)

[Benefits of the SRX4100 Firewall | 9](#)

[SRX4100 Chassis | 9](#)

[SRX4100 Services Gateway Chassis Overview | 10](#)

[SRX4100 Firewall Front Panel | 10](#)

[SRX4100 Firewall Back Panel | 15](#)

[SRX4100 Cooling System | 16](#)

[SRX4100 Power System | 17](#)

[SRX4100 Power Supply | 18](#)

[AC Power Supply Specifications for SRX4100 Services Gateways | 22](#)

[AC Power Cord Specifications for the SRX4100 Services Gateway | 22](#)

[DC Power Supply Specifications for SRX4100 Services Gateways | 24](#)

3

[Site Planning, Preparation, and Specifications](#)

[SRX4100 Site Preparation Checklist | 26](#)

[SRX4100 Site Guidelines and Requirements | 28](#)

- General Site Installation Guidelines | 28
- SRX4100 Firewall Environmental Specifications | 28
- Site Electrical Wiring Guidelines | 29
- SRX4100 Firewall Physical Specifications | 31
- Clearance Requirements for Airflow and Hardware Maintenance for SRX4100 Services Gateways | 32
- SRX4100 Firewall Rack Requirements | 33
- Cabinet Requirements for SRX4100 Services Gateways | 34

SRX4100 Transceiver Specifications and Pinouts | 35

- Pluggable Transceivers Supported on SRX4100 Services Gateways | 36
- SFP+ Direct Attach Copper Cables for SRX4100 Services Gateways | 37
- Management Port Connector Pinout Information for an SRX4100 Services Gateway | 37
- Console Port Connector Pinout Information for an SRX4100 Services Gateway | 38

4

Initial Installation and Configuration

SRX4100 Installation Overview | 41

Unpacking and Mounting the SRX4100 | 41

- Unpacking the SRX4100 Services Gateway | 42
- Verifying Parts Received with the SRX4100 Services Gateway | 42
- Installing the SRX4100 Firewall in a Rack | 43

Connecting the SRX4100 to Power | 46

- Connecting the SRX4100 Firewall Grounding Cable | 46
- Connecting AC Power to an SRX4100 Firewall | 47
- Connecting DC Power to an SRX4100 Firewall | 49

Connecting the SRX4100 Firewall to a Management Console | 52

Configuring Junos OS on the SRX4100 | 53

- SRX4100 Firewall Software Configuration Overview | 53
- SRX4100 Firewall Factory-Default Settings | 53

Viewing Factory-Default Settings | 54

Configuring the SRX4100 Services Gateway | 54

5

Maintaining Components

Routine Maintenance Procedures for the SRX4100 | 59

Maintaining the SRX4100 Power System | 59

Replacing an AC Power Supply on the SRX4100 | 60

Removing an AC Power Supply from an SRX4100 Services Gateway | 60

Installing an AC Power Supply in an SRX4100 Services Gateway | 61

Replacing a DC Power Supply on the SRX4100 | 62

Removing a DC Power Supply from an SRX4100 Services Gateway | 63

Installing a DC Power Supply in an SRX4100 Services Gateway | 63

Maintaining the SRX4100 Cooling System | 64

Replacing the SRX4100 Firewall Fan Tray | 64

6

Troubleshooting Hardware

Troubleshooting the SRX4100 | 67

Troubleshooting Resources for the SRX4100 Services Gateway | 67

Monitoring Chassis Alarms on an SRX4100 Services Gateway | 67

Using the RESET Button on the SRX4100 Services Gateway | 69

7

Contacting Customer Support and Returning the Chassis or Components

Returning the SRX4100 Chassis or Components | 72

Contacting Customer Support | 72

Returning a SRX4100 Firewall or Component to Juniper Networks | 73

Locating the Serial Number on the SRX4100 Firewall or Component | 73

Listing the SRX4100 Firewall Component Details with the CLI | 74

Locating the Chassis Serial Number ID Label | 75

Locating the Serial Number ID Labels on FRUs | 75

Packing a SRX4100 Firewall or Component for Shipping | 75

Packing the SRX4100 Firewall for Shipment | 75

Packing the SRX4100 Firewall Components for Shipment | 76

Safety and Compliance Information

General Safety Guidelines and Warnings | 79

Definitions of Safety Warning Levels | 80

Restricted Access Area Warnings | 82

Qualified Personnel Warning | 83

Prevention of Electrostatic Discharge Damage | 84

Fire Safety Requirements | 85

Laser and LED Safety Guidelines and Warnings | 87

Radiation from Open Port Apertures Warning | 90

Maintenance and Operational Safety Guidelines and Warnings | 91

General Electrical Safety Guidelines and Warnings | 97

AC Power Electrical Safety Guidelines | 102

DC Power Electrical Safety Guidelines | 103

DC Power Disconnection Warning | 104

DC Power Grounding Requirements and Warning | 106

DC Power Wiring Sequence Warning | 107

DC Power Wiring Terminations Warning | 108

Action to Take After an Electrical Accident | 109

Agency Approvals | 110

Acoustic Noise Compliance Statements | 112

EMC Requirements | 112

About This Guide

Use this guide to install hardware and perform initial software configuration, routine maintenance, and troubleshooting for the SRX4100 Firewall. After completing the installation and basic configuration procedures covered in this guide, refer to the Junos OS documentation for information about further software configuration.

RELATED DOCUMENTATION

| [How to Set Up Your SRX4100 Services Gateway](#)

1

CHAPTER

Fast Track: Initial Installation

Fast Track to Rack Installation and Power | 2

Onboard and Configure SRX4100 | 5

Fast Track to Rack Installation and Power

SUMMARY

This procedure guides you through the simplest steps to install your SRX4100 Firewall in a rack and connect it to power. Have more complex installation needs? See ["Installing the SRX4100 Firewall in a Rack"](#) on page 43.

IN THIS SECTION

- [Install the SRX4100 in a Rack](#) | 2
- [Connect to Power](#) | 3

Install the SRX4100 in a Rack

You can install the SRX4100 Firewall in a four-post rack or cabinet. We'll walk you through the steps to install an AC-powered firewall in a four-post rack.

Before you install, review the following:

- ["SRX4100 Site Guidelines and Requirements"](#) on page 28.
- [General Safety Guidelines and Warnings](#).
- ["Unpacking the SRX4100 Services Gateway"](#) on page 42.

1. Attach the mounting ears to the front of the chassis and the fixed brackets to the rear of the chassis.

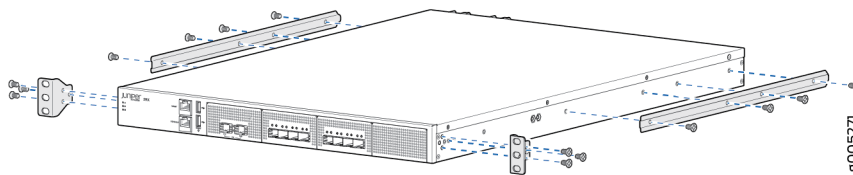

2. Slide the device into the rack, and secure the mounting ears to the rack.

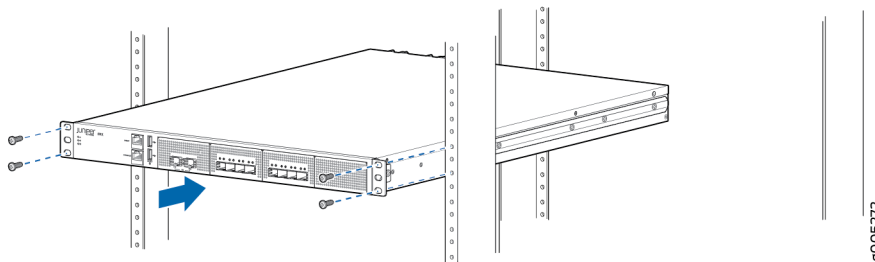

3. Slide the adjustable brackets into the fixed brackets attached to the rear of the device.

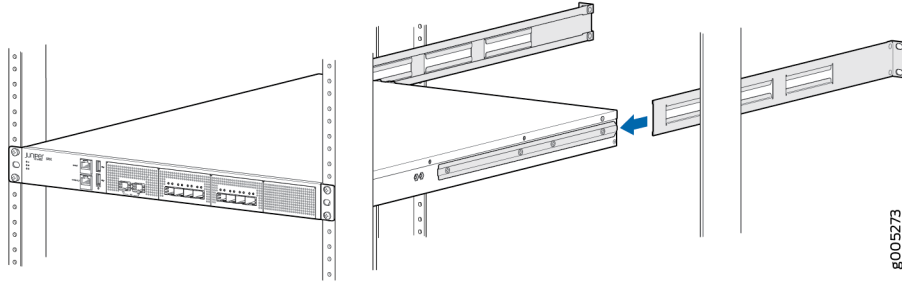

4. Secure the adjustable brackets to the rack.

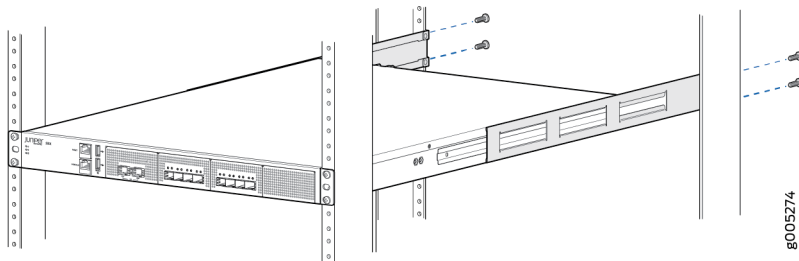

Connect to Power

IN THIS SECTION

- [Ground the SRX4100 Firewall | 3](#)
- [Connect the Power Cord and Power On the Firewall | 4](#)

To connect the SRX4100 Firewall to AC power, you must do the following:

Ground the SRX4100 Firewall

To ground the SRX4100 Firewall, do the following:

1. Attach an electrostatic discharge (ESD) grounding strap to your bare wrist, and connect the other end of the ESD strap to the ESD point on the rack.
2. Attach a grounding cable to earth ground, and attach the other end to the grounding point at the rear of the SRX4100.

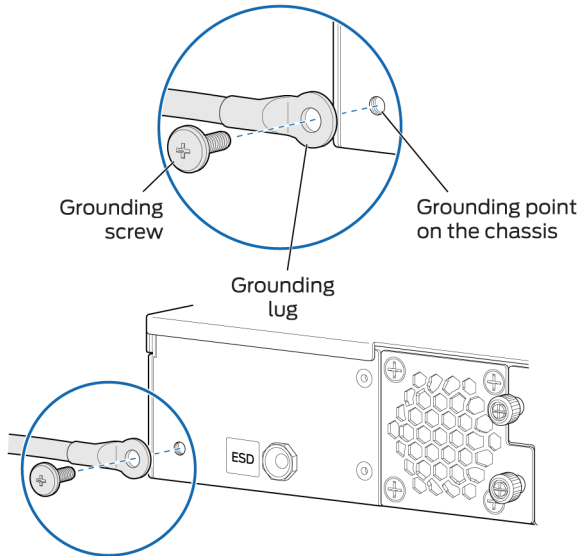

Connect the Power Cord and Power On the Firewall

To connect the power cord, do the following:

1. Ensure that the power supplies are fully inserted in the chassis and the latches are secure.
2. Plug the power cord into the AC power cord inlet on the AC power supply.
3. Push the power cord retainer onto the power cord

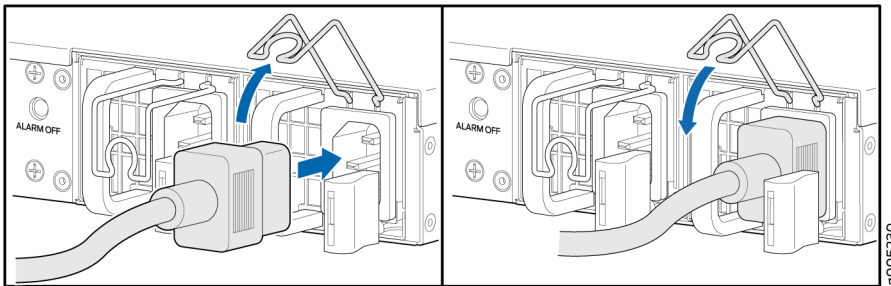

4. If the AC power source outlet has a power switch, turn it off.
5. Plug the power cord into an AC power source outlet.
6. If the AC power source outlet has a power switch, turn it on. The firewall doesn't have a power switch and powers on as soon as you plug it in.

Onboard and Configure SRX4100

SUMMARY

This topic provides you the pointers to onboard and configure SRX4100 firewalls using Juniper® Security Director, or configure SRX4100 firewalls using J-Web or Junos OS CLI.

If you have a Juniper® Security Director license, you can follow a few simple steps to get an SRX4100 up and running on the Juniper® Security Director Cloud portal. See [Table 1 on page 5](#) for more information.

Table 1: Onboard and Configure SRX4100 Using Juniper® Security Director

| If you want to | Then |
|---|---|
| Claim and onboard to Juniper® Security Director Cloud | See Onboard SRX Series Firewalls to Security Director Cloud |
| Configure additional features | See Juniper Security Director Cloud User Guide |

You can configure the SRX4100 using the J-Web GUI. See [Table 2 on page 5](#) for more information.

Table 2: Configure SRX4100 Using J-Web

| If you want to | Then |
|---|---|
| Configure additional features using J-Web | See J-Web for SRX Series Documentation |
| Set up your SRX345 with advanced security measures to protect and defend your network | See SRX Series Up and Running with Advanced Security Features |
| See, automate, and protect your network with Juniper Security | Visit the Security Design Center |

Table 2: Configure SRX4100 Using J-Web (Continued)

| If you want to | Then |
|---|--|
| Download, activate, and manage your software licenses to unlock additional features for your SRX firewall | See Activate Junos Licenses in the Juniper Licensing Guide |

You can also configure the SRX4100 using the Junos OS CLI. See [Table 3 on page 6](#) for more information.

Table 3: Configure SRX4100 Using Junos OS CLI

| If you want to | Then |
|--|---|
| Customize basic configuration | See "Configuring the SRX4100 Services Gateway" on page 54 |
| Explore the software features supported on the SRX4100 | See Feature Explorer |
| Configure Junos features on the SRX4100 | See User Guides |

2

CHAPTER

Overview

[SRX4100 Firewall Overview | 8](#)

[SRX4100 Chassis | 9](#)

[SRX4100 Cooling System | 16](#)

[SRX4100 Power System | 17](#)

SRX4100 Firewall Overview

IN THIS SECTION

- [SRX4100 Firewall Overview | 8](#)
- [Field-Replaceable Units in SRX4100 Services Gateways | 9](#)
- [Benefits of the SRX4100 Firewall | 9](#)

SRX4100 Firewall Overview

The Juniper Networks SRX4100 Firewall is a high-performance, scalable mid-range services gateway, which consolidates security, next-generation firewall, and advanced threat prevention capabilities to provide secure connectivity. The services gateway supports 20 Gbps IMIX throughput and is suited for small to medium enterprises and data centers.

The SRX4100 Firewall supports advanced threat prevention through Juniper Advanced Threat Prevention Cloud (ATP Cloud) and Spotlight Secure Threat Intelligence, in addition to key features such as VPN, IPS, and Content Security.

The chassis is 1 U high and is designed for rack installation. The services gateway is shipped with dual power supplies and is available in both AC-powered and DC-powered versions:

- SRX4100 (AC) – SRX4100 Firewall with dual AC power supplies
- SRX4100 (DC) – SRX4100 Firewall with dual DC power supplies

The SRX4100 Firewall comes with 64 GB of DDR4 memory and two 240-GB solid-state drives (SSDs) in a redundant array of independent disks (RAID). Both disks are configured as a RAID-1 mirror (data is concurrently written to both SSDs). If one SSD becomes inoperable, the other SSD continues to be active.

The services gateway runs the Junos OS and can be managed using the CLI, Junos Space, and J-Web.

SEE ALSO

[SRX4100 Firewall Physical Specifications | 31](#)

[SRX4100 Firewall Environmental Specifications | 28](#)

Field-Replaceable Units in SRX4100 Services Gateways

Field-replaceable units (FRUs) are components that you can replace at your site. The FRUs on the SRX4100 Firewall are hot-removable and hot-insertable. You can remove and replace them without powering off the services gateway. The services gateway supports the following FRUs:

- AC power supplies
- DC power supplies
- Fan trays

SEE ALSO

| [SRX4100 Power Supply | 18](#)

Benefits of the SRX4100 Firewall

- **High performance**—The SRX4100 supports up to 40-Gbps firewall throughput (up to 20-Gbps of IMIX firewall throughput) and is suited for enterprise campus and data center edge deployments.
- **Advanced threat protection**—The SRX4000 line of services gateways supports the intrusion prevention system (IPS), Juniper Juniper Advanced Threat Prevention Cloud (Juniper ATP Cloud), antivirus, and antispam features, which protect against potential vulnerabilities. Juniper ATP Cloud protects against zero-day attacks and other unknown threats.

SRX4100 Chassis

IN THIS SECTION

- [SRX4100 Services Gateway Chassis Overview | 10](#)
- [SRX4100 Firewall Front Panel | 10](#)
- [SRX4100 Firewall Back Panel | 15](#)

SRX4100 Services Gateway Chassis Overview

The 4100 Services Gateway chassis is a rigid sheet metal structure that houses all the other hardware components. The chassis measures 1.75 in. high, 17.48 in. wide, and 25 in. deep. The chassis installs in standard 600-mm deep (or larger) enclosed cabinets or 19-in. equipment racks.

 **CAUTION:** Before removing or installing components of a functioning services gateway, attach an electrostatic discharge (ESD) strap to an ESD point and place the other end of the strap around your bare wrist. Failure to use an ESD strap could result in damage to the device.

The services gateway must be connected to earth ground during normal operation.

SRX4100 Firewall Front Panel

IN THIS SECTION

- Chassis Status LEDs | 11
- Management Port LEDs | 12
- HA Port LEDs | 13
- Network Port LEDs | 14

Figure 1 on page 10 shows the front panel of the SRX4100 Firewall.

Figure 1: SRX4100 Firewall Front Panel

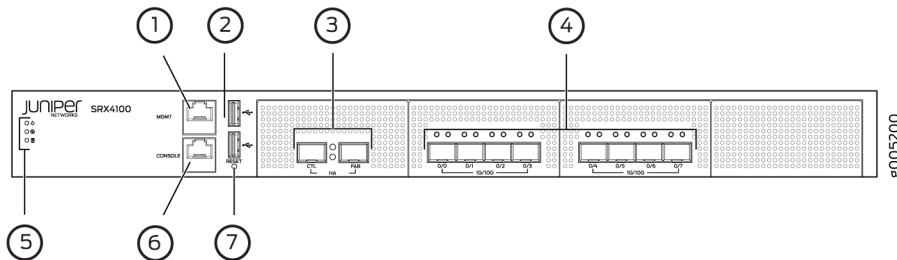

Table 4 on page 11 lists the components on the front panel of the services gateway.

Table 4: SRX4100 Firewall Components on the Front Panel

| Number | Component | Description |
|--------|-----------------|---|
| 1 | Management port | Gigabit Ethernet port to connect to the device over the network. |
| 2 | USB ports | Two USB 2.0 ports that accept a USB storage device. |
| 3 | HA ports | Two 1-Gigabit Ethernet/10-Gigabit Ethernet ports, CTL (control port) and FAB (fabric port), to synchronize data and maintain state information in a chassis cluster setup. These ports support enhanced small form-factor pluggable (SFP/SFP+) transceivers. |
| 4 | SFP+ ports | <p>Eight 1-Gigabit Ethernet/10-Gigabit Ethernet SFP+ ports for network traffic.</p> <p>NOTE: Ports 0/0 to 0/3 are part of a port group that is connected to one CPU socket. Similarly, ports 0/4 to 0/7 form another port group and are connected to a different CPU socket.</p> <p>When choosing ports for network traffic, ensure that you use the ports equally from each socket so that the traffic is evenly distributed, and the overall CPU load is balanced. For example, if you plan to use two ports, then choose one port from each socket. If the network traffic passes only through the ports in one group, you might encounter performance and load balancing issues.</p> |
| 5 | LEDs | Indicate component and system status at a glance. |
| 6 | Console port | Connects a laptop to the services gateway for CLI management. The port uses an RJ-45 serial connection, is configured as DTE, and supports the RS-232 (EIA-232) standard. |
| 7 | Reset button | Returns the services gateway to the factory-default configuration. |

Chassis Status LEDs

Figure 2 on page 12 shows the LEDs on the front panel, and Table 5 on page 12 describes the LEDs.

Figure 2: SRX4100 Firewall Front Panel LEDs



Table 5: SRX4100 Firewall Front Panel LEDs

| LED | Description |
|--------|---|
| Power | <ul style="list-style-type: none"> • Solid green—receiving power |
| Status | <ul style="list-style-type: none"> • Solid green—operating normally • Solid red—critical alarm <ul style="list-style-type: none"> • Hardware component failure • Software module failure • Fan failure (atleast one) • Blinking red—noncritical alarm <ul style="list-style-type: none"> • The other HA node is in the lost, disabled, or ineligible state. • Off—the system is not receiving power |
| SSD | <ul style="list-style-type: none"> • Blinking green—indicates hard disk drive (SSD) activity |

Management Port LEDs

The management port has two LEDs that indicate link activity and status of the management port.

[Table 6 on page 13](#) describes the LEDs.

Table 6: Management Port LEDs

| LED | Description |
|---------------------------------|---|
| Link/Activity (LED on the left) | <ul style="list-style-type: none"> • Solid amber—A link is established, but there is no activity on the link. • Blinking amber—There is link activity. • Off—There is no link established. |
| Speed (LED on the right) | <ul style="list-style-type: none"> • Solid green—100-Mbps link is established. • Solid amber—1000-Mbps link is established. • Off—There is no link established. |

HA Port LEDs

Each HA port has one status LED located between the ports. [Figure 3 on page 13](#) shows the LEDs. The upper LED (callout 1) displays the status for the port on the right and the lower LED (callout 2) displays the status for the port on the left. [Table 7 on page 14](#) describes the LEDs.

Figure 3: HA Port LEDs

Table 7: HA Port LEDs

| LED | Description |
|------------|---|
| Status LED | <ul style="list-style-type: none"> • Solid amber—A link is established. • Blinking amber—There is link activity. • Off—There is no link established. |

Network Port LEDs

Each SFP+ port has two status LEDs located above the port. [Table 8 on page 14](#) describes the LEDs. [Figure 4 on page 14](#) shows the LEDs.

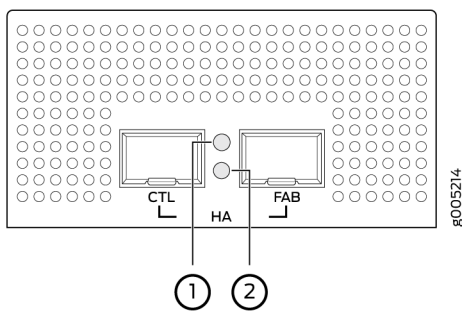
Figure 4: Network Port LEDs

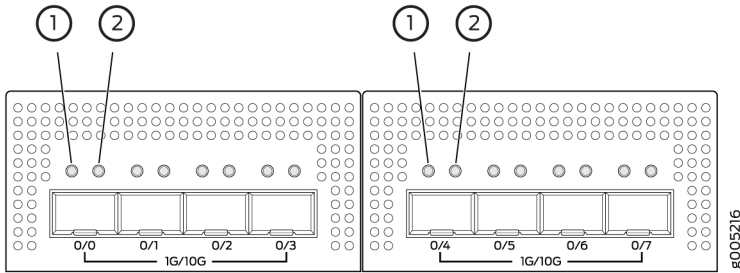

Table 8: Network Port LEDs

| Callout | LED | Description |
|---------|-----------------------------------|--|
| 1 | Link (LED on the left) | <ul style="list-style-type: none"> • Solid green—There is link activity. • Off—There is no link established. |
| 2 | Speed/Activity (LED on the right) | <ul style="list-style-type: none"> • Solid amber—10 G/1 G link is established. • Blinking amber—There is activity on the 10 G/1 G link. • Off—There is no link established. |

SRX4100 Firewall Back Panel

Figure 5 on page 15 shows the back panel of the SRX4100 Firewall, and Table 9 on page 15 lists and describes the back panel components.

Figure 5: SRX4100 Firewall Back Panel

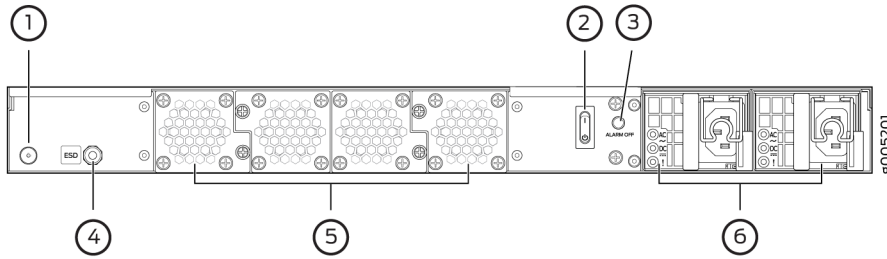

Table 9: SRX4100 Firewall Back Panel Components

| Number | Component | Description |
|--------|------------------|---|
| 1 | Grounding point | Connects the services gateway chassis to earth ground. |
| 2 | Power switch | Use the Power switch to power on or power off the services gateway. |
| 3 | Alarm Off button | Use this button to turn off an alarm triggered because of an abnormal DC output voltage caused by any of the following: <ul style="list-style-type: none"> • Only one power supply unit is plugged in. • The AC power cord is not plugged in. • The power supply unit is not functional and there is no DC output. |
| 4 | ESD point | For personal safety, while working on the services gateway, use the ESD outlet to plug in an ESD grounding strap to prevent your body from sending static charges to the services gateway. |

Table 9: SRX4100 Firewall Back Panel Components (Continued)

| Number | Component | Description |
|--------|--------------|--|
| 5 | Fan trays | <p>Four fan trays for cooling the services gateway and its components. Each fan tray contains two fans.</p> <p>Three fan trays are required for proper air flow across the chassis internal components. The fourth fan tray provides redundancy.</p> |
| 6 | Power supply | Two power supply slots. Each power supply contains a power cord outlet. Two 650-W DC or AC power supplies are provided with the services gateway. |

SRX4100 Cooling System

The cooling system for the services gateway consists of four fan trays located at the rear of the chassis. Each fan tray contains two fans, so there are a total of eight fans. The fans draw cool air through vents on the front of the chassis and exhaust the air through the back of the chassis. See [Figure 6 on page 17](#). The airflow produced by the fans keeps device components within the acceptable temperature range.

If any one of the four fan trays fails, the services gateway generates a warning but keeps the system running. If the temperature keeps rising, the services gateway lowers the power consumption by reducing the performance or shutting down some of the chassis components. However, if the ambient maximum temperature exceeds the warning level and the system cannot be adequately cooled, then the services gateway shuts down the system and hardware components completely.

The fan trays are hot-swappable field-replaceable units (FRUs). The fans are not field-replaceable.

Figure 6: Airflow Through the Chassis

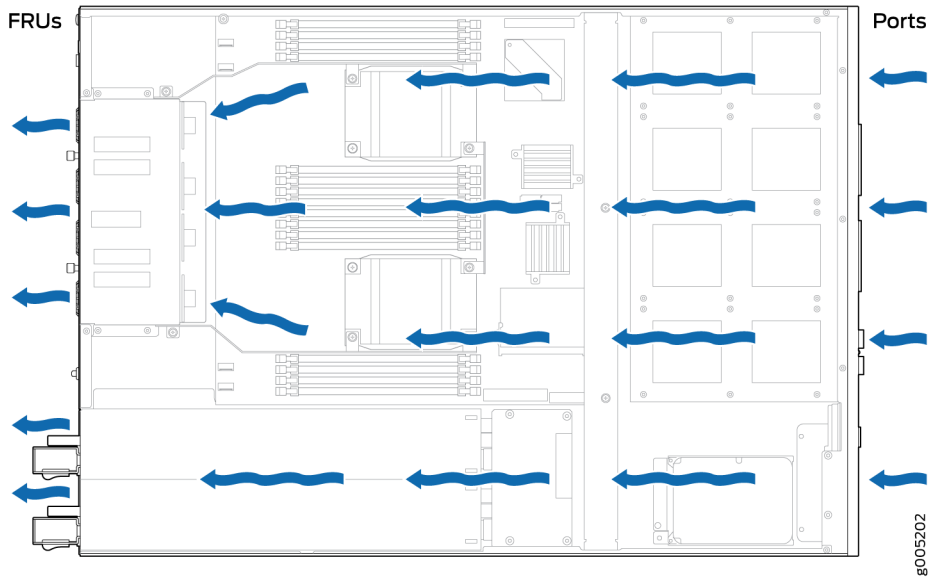

RELATED DOCUMENTATION

Clearance Requirements for Airflow and Hardware Maintenance for SRX4100 Services Gateways | 32

SRX4100 Power System

IN THIS SECTION

- SRX4100 Power Supply | 18
- AC Power Supply Specifications for SRX4100 Services Gateways | 22
- AC Power Cord Specifications for the SRX4100 Services Gateway | 22
- DC Power Supply Specifications for SRX4100 Services Gateways | 24

SRX4100 Power Supply

IN THIS SECTION

- AC Power Supply | 18
- DC Power Supply | 20

The SRX4100 Firewall is shipped with two AC or two DC power supply units preinstalled in the rear panel. Each power supply provides power to all components in the services gateway. If one power supply fails or is removed, the remaining power supply redistributes the electrical load without interruption. Each power supply is cooled by its own internal cooling system.

AC Power Supply

Each AC power supply weighs approximately 2.3 lb and consists of one AC appliance inlet, a fan, and LEDs for monitoring the status of the power supply. The AC power supply is a hot-insertable and hot-removable field-replaceable unit (FRU) when the second power supply is installed and running. You can install the replacement power supply without powering off the services gateway. The AC power supply gives an output of 650 W and supports both low line voltage (100–127 VAC) and high line voltage (200–240 VAC). [Figure 7 on page 18](#) shows the AC power supply.

Figure 7: AC Power Supply

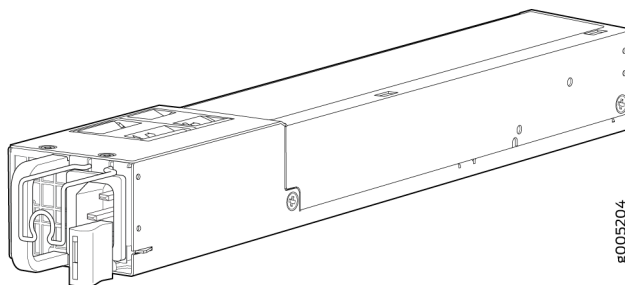

[Figure 8 on page 19](#) shows the location of the LEDs on an AC power supply. Each AC power supply faceplate contains three LEDs that indicate the status of the power supplies.

Figure 8: AC Power Supply LEDs

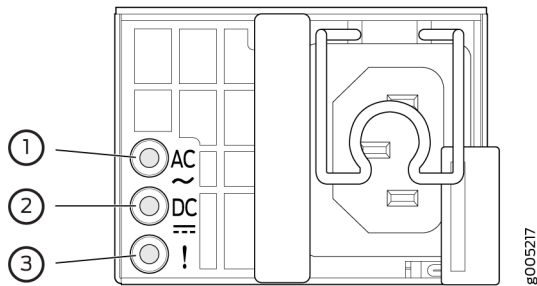

Table 10 on page 19 describes the AC power supply LEDs.

Table 10: AC Power Supply LEDs

| LED | Color | State | Description |
|-----------|-------|-------------|--|
| AC | Unlit | Off | Indicates one of the following: <ul style="list-style-type: none"> Power input voltage is not within the normal operating range. No power input. |
| | Green | Steady | Input power present and is within the normal operating range. |
| DC | Unlit | Off | No DC power output or abnormal DC output. |
| | Green | On steadily | DC power output is within the normal operating range. |
| ! (Fault) | Amber | On steadily | Power supply unit failure. |
| | | Blinking | Invalid power supply unit. |
| | Unlit | Off | Power supply unit is functioning normally. |

NOTE:

- If both the AC LED and the DC LED are unlit, either the AC power cord is not installed properly or the power supply fuse has failed.
- If the AC LED is lit and the DC LED is unlit, the AC power supply is installed properly, but the power supply has an internal failure.

DC Power Supply

Each DC power supply weighs approximately 2.2 lb and has two independent pairs of DC input lugs, a fan, and LEDs for monitoring the status of the power supply. The DC power supply in the services gateway is a hot-insertable and hot-removable field-replaceable unit (FRU) when the second power supply is installed and running. You can install a replacement power supply without powering off the services gateway. The DC power supply gives an output of 650 W. [Figure 9 on page 20](#) shows the DC power supply.

Figure 9: DC Power Supply

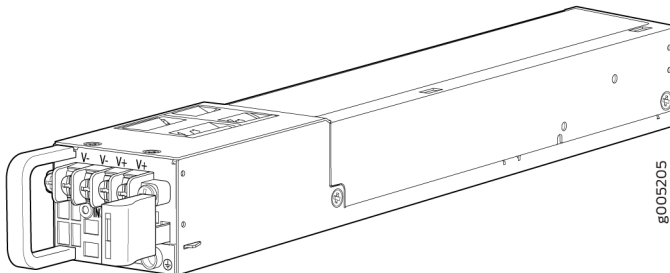

The DC power supply requires a dedicated circuit breaker rated for 9 A (-48 VDC) minimum, or as required by local code.

[Figure 10 on page 21](#) shows the location of the LEDs on a DC power supply. Each DC power supply faceplate contains three LEDs that indicate the status of the power supplies.

Figure 10: DC Power Supply LEDs

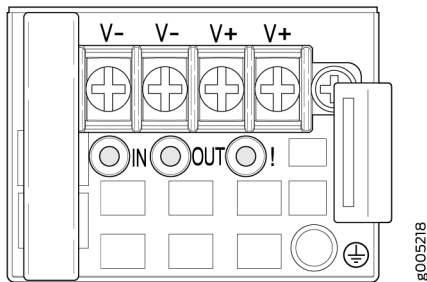

Table 11 on page 21 describes the DC power supply LEDs.

Table 11: DC Power Supply LEDs

| LED | Color | State | Description |
|-----------|-------|-------------|--|
| IN | Unlit | Off | Indicates one of the following: <ul style="list-style-type: none"> Power input voltage is not within the normal operating range. No power input. |
| | Green | On steadily | Input power present and is within the normal operating range. |
| OUT | Unlit | Off | No DC power output or abnormal DC output. |
| | Green | On steadily | DC power output is within the normal operating range. |
| ! (Fault) | Amber | On steadily | Power supply unit failure. |
| | | Blinking | Invalid power supply unit. |
| | Unlit | Off | Power supply unit is functioning normally. |

AC Power Supply Specifications for SRX4100 Services Gateways

Table 12 on page 22 lists the specifications for an AC power supply.

Table 12: AC Power Supply Specifications

| Item | Specification |
|---|--|
| AC input voltage | Operating range: <ul style="list-style-type: none"> • Low-voltage line—100–127 VAC • High-voltage line—200–240 VAC |
| AC input line frequency | 50–60 Hz |
| AC input current rating | <ul style="list-style-type: none"> • Low-voltage line—4 A • High-voltage line—2 A |
| AC output power | <ul style="list-style-type: none"> • Low-voltage line—650 W • High-voltage line—650 W |
| Maximum System Power Requirement | 440 W |
| System Thermal Output = (Maximum System Power Requirement) * 3.41 Note: 1 W = 3.41 BTU/Hour | 1500 BTU/Hour |

AC Power Cord Specifications for the SRX4100 Services Gateway

A detachable AC power cord is supplied with the AC power supplies. The coupler is type C13 as described by International Electrotechnical Commission (IEC) standard 60320.

NOTE: In North America, AC power cords must not exceed 4.5 m (approximately 14.75 ft) in length, to comply with National Electrical code (NEC) Section 400-8 (NFPA 75, 5-2.2) and 210-52, and Canadian Electrical Code (CEC) Section 4-010(3).

Table 13 on page 23 provides power cord specifications, and Figure 11 on page 23 depicts the plug on the AC power cord provided for each country or region.

Table 13: AC Power Cord Specifications

| Country | Electrical Specification | Plug Standards |
|--|----------------------------|--|
| Australia | 250 VAC, 10 A, 50 Hz | AS/NZ 3112-1993 |
| China | 250 VAC, 10 A, 50 Hz | GB2099.1 1996 and GB 1002 1996 (CH1-10P) |
| Europe (except Italy and United Kingdom) | 250 VAC, 10 A, 50 Hz | CEE (7) VII |
| Italy | 250 VAC, 10 A, 50 Hz | CEI 23-16/VII |
| Japan | 125 VAC, 12 A, 50 or 60 Hz | JIS 8303 |
| North America | 125 VAC, 10 A, 60 Hz | NEMA 5-15 |
| United Kingdom | 250 VAC, 10 A, 50 Hz | BS 1363A |

Figure 11: AC Plug Types



NOTE: Power cords and cables must not block access to services gateway components or drape where people might trip on them.



CAUTION: The AC power cord for the services gateway is intended for use with the services gateway only and not for any other use.

DC Power Supply Specifications for SRX4100 Services Gateways

Table 14 on page 24 lists the power supply specifications for a DC power supply.

Table 14: DC Power Supply Specifications

| Item | Specifications |
|-------------------------|--|
| DC input voltage | <ul style="list-style-type: none"> • Minimum operating voltage: -40 VDC • Nominal operating voltage: -48 VDC • Operating voltage range: -40 VDC through -72 VDC |
| DC input current rating | 9 A maximum at nominal operating voltage |
| Output power | 650 W |

RELATED DOCUMENTATION

[Connecting the SRX4100 to Power | 46](#)

[Maintaining the SRX4100 Power System | 59](#)

3

CHAPTER

Site Planning, Preparation, and Specifications

SRX4100 Site Preparation Checklist | 26

SRX4100 Site Guidelines and Requirements | 28

SRX4100 Transceiver Specifications and Pinouts | 35

SRX4100 Site Preparation Checklist

Table 15 on page 26 provides a checklist of tasks you need to perform when preparing a site for installing the SRX4100 Firewall.

Table 15: Site Preparation Checklist for SRX4100 Firewall Installation

| Item or Task | Additional Information | Performed By | Date | Notes |
|---|--|--------------|------|-------|
| <i>Power</i> | | | | |
| Measure distance between external power sources and device installation site. | | | | |
| Locate sites for connection of system grounding. | | | | |
| Calculate the power consumption and requirements. | "AC Power Supply Specifications for SRX4100 Services Gateways" on page 22 "DC Power Supply Specifications for SRX4100 Services Gateways" on page 24 | | | |
| <i>Environment</i> | | | | |
| Verify that environmental factors such as temperature and humidity do not exceed device tolerances. | "SRX4100 Services Gateway Environmental Specifications" on page 28 | | | |
| <i>Rack or Cabinet</i> | | | | |

Table 15: Site Preparation Checklist for SRX4100 Firewall Installation (Continued)

| Item or Task | Additional Information | Performed By | Date | Notes |
|--|--|--------------|------|-------|
| Verify that your rack or cabinet meets the minimum requirements for the installation of the device. | "SRX4100 Services Gateway Rack Requirements" on page 33 "Cabinet Requirements for SRX4100 Services Gateways" on page 34 | | | |
| Plan rack location, including required space clearances. | | | | |
| Secure the rack or cabinet to the floor and building structure. | | | | |
| <i>Cables</i> | | | | |
| Acquire cables and connectors: <ul style="list-style-type: none"> • Determine the number of cables needed based on your planned configuration. • Review the maximum distance allowed for each cable. Choose the length of cable based on the distance between the hardware components being connected. | | | | |
| Plan the cable routing and management. | | | | |

RELATED DOCUMENTATION
[SRX4100 Installation Overview](#) | 41

SRX4100 Site Guidelines and Requirements

IN THIS SECTION

- [General Site Installation Guidelines | 28](#)
- [SRX4100 Firewall Environmental Specifications | 28](#)
- [Site Electrical Wiring Guidelines | 29](#)
- [SRX4100 Firewall Physical Specifications | 31](#)
- [Clearance Requirements for Airflow and Hardware Maintenance for SRX4100 Services Gateways | 32](#)
- [SRX4100 Firewall Rack Requirements | 33](#)
- [Cabinet Requirements for SRX4100 Services Gateways | 34](#)

General Site Installation Guidelines

To plan and create an acceptable operating environment for your services gateway and prevent environmentally caused equipment failures:

- Follow the prescribed electrostatic discharge (ESD) prevention procedures to prevent damaging the equipment. Static discharge can cause components to fail completely or intermittently over time.
- Follow prescribed airflow guidelines to ensure that the cooling system functions properly. The airflow around the chassis must be unrestricted. Allow sufficient clearance between the front and back of the chassis and adjacent equipment. Ensure that there is adequate circulation in the installation location.
- Keep the area around the chassis clear and free from dust.

SRX4100 Firewall Environmental Specifications

[Table 16 on page 29](#) provides the required environmental conditions for normal SRX4100 Firewall operations. In addition, the site must be as dust-free as possible because dust can clog air intake vents, reducing the efficiency of the cooling system.

Table 16: Environmental Specifications

| Description | Value |
|-------------------|--|
| Altitude | No performance degradation up to 6,562 feet (2000 meters). |
| Relative humidity | Normal operation ensured in relative humidity range of 5% through 90%, noncondensing. |
| Temperature | <ul style="list-style-type: none"> • Normal operation ensured in temperature range of 32° F through 104° F (0° C through 40° C). • Nonoperating storage temperature in shipping container: -40° F through 158° F (-40° C through 70° C). |

Site Electrical Wiring Guidelines

Table 17 on page 30 describes the factors you must consider while planning the electrical wiring at your site.



CAUTION: It is particularly important to provide a properly grounded and shielded environment and to use electrical surge-suppression devices.

Table 17: Site Electrical Wiring Guidelines

| Site Wiring Factor | Guideline |
|-------------------------------------|---|
| Signaling limitations | <p>To ensure that signaling functions optimally:</p> <ul style="list-style-type: none"> • Install wires correctly. Improperly installed wires can emit radio interference. • Do not exceed the recommended distances or pass wires between buildings. The potential for damage from lightning strikes increases if wires exceed recommended distances or if wires pass between buildings. • Shield all conductors. The electromagnetic pulse (EMP) caused by lightning can damage unshielded conductors and destroy electronic devices. |
| Radio frequency interference (RFI) | <p>To reduce or eliminate the emission of RFI from your site wiring:</p> <ul style="list-style-type: none"> • Use twisted-pair cable with a good distribution of grounding conductors. • Use a high-quality twisted-pair cable with one ground conductor for each data signal when applicable, if you must exceed the recommended distances. |
| Electromagnetic compatibility (EMC) | <p>Provide a properly grounded and shielded environment and use electrical surge-suppression devices.</p> <p>Strong sources of electromagnetic interference (EMI) can cause the following damage:</p> <ul style="list-style-type: none"> • Destruction of the signal drivers and receivers in the device. • Electrical hazards as a result of power surges conducted over the lines into the equipment. <p>TIP: If your site is susceptible to problems with EMC, particularly from lightning or radio transmitters, you might want to seek expert advice.</p> |



WARNING: Some ports are designed for use as intrabuilding interfaces only. Type 2 or Type 4 ports, the battery return connection is to be treated as an Isolated DC return (that is, DC-I), as defined in GR-1089-CORE and require isolation from the exposed OSP cabling. To comply with NEBS requirements and protect against lightning surges and

commercial power disturbances, the intrabuilding port(s) of the device **MUST NOT** be metalically connected to interfaces that connect to the OSP or its wiring. The intrabuilding port(s) of the device is suitable for connection to intrabuilding or unexposed wiring or cabling only. The addition of primary protectors is not sufficient protection to connect these interfaces metalically to OSP wiring.

SRX4100 Firewall Physical Specifications

The SRX4100 Firewall chassis is a rigid sheet metal structure that houses all the components. [Table 18 on page 31](#) lists the physical specifications of the SRX4100 Firewall chassis.

Table 18: Physical Specifications for the Services Gateway Chassis

| Description | Value |
|----------------|--|
| Chassis height | 1.75 in. (4.45 cm) |
| Chassis width | 17.48 in. (44.40 cm) |
| Chassis depth | 25 in. (63.50 cm) |
| Weight | <ul style="list-style-type: none"> • Services gateway with 2 AC power supplies: 29 lb (13.15 kg) • Services gateway with 2 DC power supplies: 28.8 lb (13.06 kg) • AC power supply: 2.3 lb (1.04 kg) • DC power supply: 2.2 lb (0.99 kg) |

You can mount the SRX4100 Firewall on a standard 19-in. four-post rack or in a standard 19-in. enclosed cabinet.

SEE ALSO

[SRX4100 Firewall Front Panel | 10](#)

[SRX4100 Firewall Back Panel | 15](#)

Clearance Requirements for Airflow and Hardware Maintenance for SRX4100 Services Gateways

When planning the installation site, you need to allow sufficient clearance around the services gateway. Consider the following:

- For the cooling system to function properly, the airflow around the chassis must be unrestricted. See [Figure 12 on page 32](#).

Figure 12: Airflow Through the Chassis

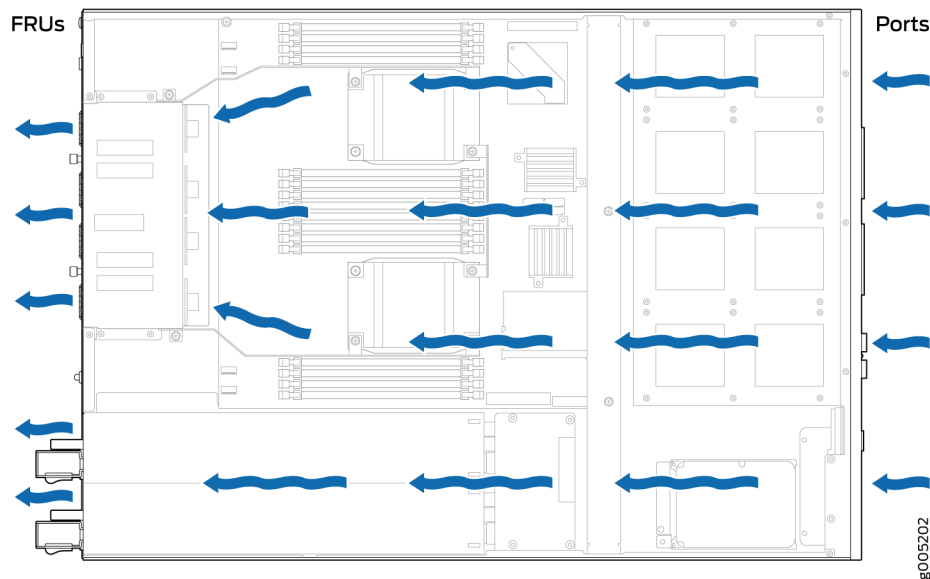

- If you are mounting the services gateway on a rack or cabinet along with other equipment, ensure that the exhaust from other equipment does not blow into the intake vents of the chassis.
- For service personnel to remove and install hardware components, there must be adequate space at the front and back of the services gateway as indicated in [Table 19 on page 33](#).

[Table 19 on page 33](#) provides information about the clearance requirements for maintaining optimum airflow and the distances necessary to facilitate easy maintenance of the services gateway.

Table 19: Clearance Requirements for the SRX4100 Services Gateway

| Location | Recommended Clearance | Requirement for Clearance |
|---|-----------------------|---|
| Front of the chassis | 34.25 in. (87 cm) | Space for service personnel to remove and install hardware components |
| Rear of the chassis | 17.4 in. (44.2 cm) | Space for service personnel to remove and install hardware components |
| Between front-mounting flange and rack or cabinet edge | 2.5 in. (6.35 cm) | Space for cable management and organization |
| Between both sides of the chassis and any non-heat-producing surface such as a wall or cabinet side | 6.0 in. (15.24 cm) | Space for the cooling system to function properly and to maintain unrestricted airflow around the chassis |

SEE ALSO

| [SRX4100 Cooling System](#) | 16

SRX4100 Firewall Rack Requirements

The SRX4100 Firewall is designed to be installed on four-post racks. [Table 20 on page 34](#) provides the rack requirements and specifications for the services gateway.

Table 20: Rack Requirements

| Rack Requirement | Guidelines |
|---------------------------------------|--|
| Rack type | <p>Use a four-post rack that provides bracket holes or hole patterns spaced at 1 U (1.75 in. or 4.45 cm) increments and that meets the size and strength requirements to support the weight.</p> <p>A U is the standard rack unit defined in Cabinets, Racks, Panels, and Associated Equipment (document number EIA-310-D) published by the Electronics Industry Association (http://www.eia.org).</p> |
| Mounting bracket hole spacing | <p>The holes in the mounting brackets are spaced at 1 U (1.75 in. or 4.45 cm), so that the device can be mounted in any rack that provides holes spaced at that distance.</p> |
| Rack size and strength | <ul style="list-style-type: none"> • Ensure that the rack complies with the size and strength standards of a 19-in. rack as defined in Cabinets, Racks, Panels, and Associated Equipment (document number EIA-310-D) published by the Electronics Industry Association (http://www.eia.org). • The rack must be strong enough to support the weight of the services gateway. • Ensure that the spacing of rails and adjacent racks provides for proper clearance around the services gateway and rack. |
| Rack connection to building structure | <ul style="list-style-type: none"> • Secure the rack to the building structure. • If earthquakes are a possibility in your geographical area, secure the rack to the floor. • Secure the rack to the ceiling brackets as well for maximum stability. |

SEE ALSO

| [Installing the SRX4100 Firewall in a Rack](#) | 43

Cabinet Requirements for SRX4100 Services Gateways

You can install the SRX4100 Firewall in a 19 in. (48.7 cm) cabinet. [Table 21 on page 35](#) provides the cabinet requirements and specifications.

Table 21: Cabinet Requirements and Specifications

| Cabinet Requirement | Guideline |
|------------------------------|--|
| Cabinet size | You can mount the services gateway in a cabinet that contains a 19-in. rack as defined in Cabinets, Racks, Panels, and Associated Equipment (document number EIA-310-D) published by the Electronics Industry Association (http://www.ecianow.org/standards-practices/standards/). |
| Cabinet clearance | <ul style="list-style-type: none"> • The outer edges of the mounting brackets extend the width of the chassis to 19 in. (48.2 cm). • The minimum total clearance inside the cabinet is 30 in. (76.2 cm) between the inside of the front door and the inside of the rear door. |
| Cabinet airflow requirements | <p>When you mount services gateway in a cabinet, you must ensure that ventilation through the cabinet is sufficient to prevent overheating.</p> <ul style="list-style-type: none"> • Install the services gateway as close as possible to the front of the cabinet so that the cable management system clears the inside of the front door. Installing the chassis close to the front of the cabinet maximizes the clearance in the rear of the cabinet for critical airflow. • Ensure adequate cool air supply to dissipate the thermal output of the services gateway. • Route and dress all cables to minimize the blockage of airflow to and from the chassis. • A cabinet larger than the minimum required provides better airflow and reduces the chance of overheating. |

SRX4100 Transceiver Specifications and Pinouts

IN THIS SECTION

- [Pluggable Transceivers Supported on SRX4100 Services Gateways | 36](#)
- [SFP+ Direct Attach Copper Cables for SRX4100 Services Gateways | 37](#)

- [Management Port Connector Pinout Information for an SRX4100 Services Gateway | 37](#)
- [Console Port Connector Pinout Information for an SRX4100 Services Gateway | 38](#)

Pluggable Transceivers Supported on SRX4100 Services Gateways

The ports on the SRX4100 Firewall supports SFP+ transceivers. The following are the transceivers supported on the services gateway:

- EX-SFP-1GE-T
- EX-SFP-10GE-ER
- SRX-SFP-10GE-ER
- SRX-SFP-10GE-LR
- SRX-SFP-10GE-SR
- JNP-10G-SR-8PACK
- SRX-SFP-1GE-LH
- SRX-SFP-1GE-LX
- SRX-SFP-1GE-SX
- JNP-1G-SX-8PACK
- SRX-SFP-1GE-T

NOTE: The SRX4100 Firewall supports only 1000 Mbps speed on SRX-SFP-1GE-T and EX-SFP-1GE-T; 10-Mbps and 100-Mbps speeds are not supported.

- JNP-1G-T-8PACK

For the full specifications of these transceivers, see [The Hardware Compatibility Tool](#).

NOTE: When using 1-gigabit transceivers, the name of the interface follows the convention `xe-0/0/port-number` but the interface operates at 1-Gbps speed.

SFP+ Direct Attach Copper Cables for SRX4100 Services Gateways

Small form-factor pluggable plus transceiver (SFP+) direct attach copper (DAC) cables are suitable for short distances of up to 23 ft (7 m), making them ideal for highly cost-effective networking connectivity within a rack and between adjacent racks. The SRX4100 Firewall supports the following 1 m and 3 m long DAC cables:

- SRX-SFP-10GE-DAC-1M
- SRX-SFP-10GE-DAC-3M

For the full specifications of these transceivers, see [The Hardware Compatibility Tool](#).

Management Port Connector Pinout Information for an SRX4100 Services Gateway

The port on the front panel labeled MGMT is an autosensing 10/100/1000-Mbps Ethernet RJ-45 receptacle that accepts an Ethernet cable for connecting the services gateway to a management LAN (or other device that supports out-of-band management). Two LEDs on the port indicate link activity on the port and the administrative status of the port.

[Table 22 on page 37](#) provides the pinout information for the RJ-45 connector for the management port. An RJ-45 cable, with a connector attached, is supplied with the services gateway.

Table 22: Management Port Connector Pinout Information

| Pin | Signal |
|-----|--------|
| 1 | TX+ |
| 2 | TX- |

Table 22: Management Port Connector Pinout Information (Continued)

| Pin | Signal |
|-----|---------------------|
| 3 | RX+ |
| 4 | Termination network |
| 5 | Termination network |
| 6 | RX- |
| 7 | Termination network |
| 8 | Termination network |

Console Port Connector Pinout Information for an SRX4100 Services Gateway

The console port is an RS-232 serial interface that uses an RJ-45 connector to connect to a console management device. The default baud rate for the console port is 9600 baud.

[Table 23 on page 38](#) provides the pinout information for the RJ-45 console connector. An Ethernet cable that has an RJ-45 connector at either end and an RJ-45 to DB-9 serial port adapter are supplied with the services gateway.

Table 23: Console Port Connector Pinout Information

| Pin | Signal | Description |
|-----|--------|---------------------|
| 1 | RTS | Request to Send |
| 2 | DTR | Data Terminal Ready |

Table 23: Console Port Connector Pinout Information (Continued)

| Pin | Signal | Description |
|-----|---------|----------------|
| 3 | TXD | Transmit Data |
| 4 | Ground | Signal Ground |
| 5 | Ground | Signal Ground |
| 6 | RXD | Receive Data |
| 7 | DSR/DCD | Data Set Ready |
| 8 | CTS | Clear to Send |

4

CHAPTER

Initial Installation and Configuration

SRX4100 Installation Overview | 41

Unpacking and Mounting the SRX4100 | 41

Connecting the SRX4100 to Power | 46

Connecting the SRX4100 Firewall to a Management Console | 52

Configuring Junos OS on the SRX4100 | 53

SRX4100 Installation Overview

To install and connect an SRX4100 Firewall:

1. Follow instructions in ["Unpacking the SRX4100 Services Gateway" on page 42](#).
2. Install power supplies if they are not preinstalled. See:
 - ["Installing an AC Power Supply in an SRX4100 Services Gateway" on page 61](#)
 - ["Installing a DC Power Supply in an SRX4100 Services Gateway" on page 63](#)
3. Mount the services gateway as described in ["Installing the SRX4100 Services Gateway in a Rack" on page 43](#).
4. Connect the grounding cable as described in ["Connecting the SRX4100 Services Gateway Grounding Cable" on page 46](#).
5. Follow instructions for connecting power as appropriate for your site. See:
 - ["Connecting AC Power to an SRX4100 Services Gateway" on page 47](#)
 - ["Connecting DC Power to an SRX4100 Services Gateway" on page 49](#)
6. Perform initial configuration by following the instructions in ["Configuring the SRX4100 Services Gateway" on page 54](#).

Unpacking and Mounting the SRX4100

IN THIS SECTION

- [Unpacking the SRX4100 Services Gateway | 42](#)
- [Verifying Parts Received with the SRX4100 Services Gateway | 42](#)
- [Installing the SRX4100 Firewall in a Rack | 43](#)

Unpacking the SRX4100 Services Gateway

The services gateway is shipped in a cardboard carton, secured with foam packing material. The carton also contains an accessory box and quick-start instructions.



CAUTION: The services gateway is maximally protected inside the cardboard carton. Do not unpack it until you are ready to begin installation.

To unpack the services gateway:

1. Move the cardboard carton to a staging area as close to the installation site as possible, where you have enough room to remove the components from the chassis.
2. Open the carton.
3. Pull out the packing material holding the services gateway in place.
4. Verify the parts received against the inventory (packing list). The packing list specifies the part numbers and carries a brief description of each part in your order.
5. Save the shipping carton and packing materials in case you need to move or ship the services gateway at a later time.

Verifying Parts Received with the SRX4100 Services Gateway

A packing list is included in each shipment. Check the parts in the shipment against the items on the packing list. The packing list specifies the part numbers and descriptions of each part in your order.

If any part is missing, contact a customer service representative.

NOTE: The parts shipped with your services gateway can vary depending on the configuration you ordered.

Table 24 on page 42 lists the parts and their quantities in the packing list.

Table 24: Parts List for a Fully Configured Services Gateway

| Component | Quantity |
|------------------|----------|
| Services gateway | 1 |

Table 24: Parts List for a Fully Configured Services Gateway (Continued)

| Component | Quantity |
|---|------------|
| Power supply (preinstalled) | 2 AC or DC |
| AC power cord appropriate for your geographical location (only for AC models) | 2 |
| Rack mount kit | 1 |
| Documentation Roadmap and Product Warranty | 1 |
| ROHS Card | 1 |
| End User License Agreement | 1 |
| Safety Guide | 1 |
| DB-9 to RJ-45 cable | 1 |
| RJ-45 cables | 2 |

Installing the SRX4100 Firewall in a Rack

You can mount the services gateway on four posts in a 19-in. rack or cabinet by using the rack-mount kit shipped with the device. (The remainder of this topic uses rack to mean rack or cabinet.)

Before mounting the device on four posts in a rack:

1. Verify that the site meets the requirements described in "[SRX4100 Site Preparation Checklist](#)" on [page 26](#).
2. Place the rack or cabinet in its permanent location, allowing adequate clearance for airflow and maintenance, and secure it to the building structure.

3. Verify that the rack or cabinet meets the specific requirements described in "[SRX4100 Services Gateway Rack Requirements](#)" on page 33 and "[Cabinet Requirements for SRX4100 Services Gateways](#)" on page 34.
4. Remove the services gateway from the shipping carton (see "[Unpacking the SRX4100 Services Gateway](#)" on page 42).

Ensure that you have the following parts and tools available:

- Phillips (+) screwdriver, number 2
- Fourteen flat-head screws (provided with the rack mount kit)
- Eight rack-mounting screws to secure the chassis to the rack (not provided with the rack mount kit)

NOTE:

- Installing the device in a rack requires two people: one person lifts the device while the other secures it to the rack.
- If you are installing multiple devices in one rack, install the lowest one first and proceed upward in the rack.

To mount the services gateway in a four-post rack:

1. Attach the mounting ears to the front of the chassis, using the screws provided. Then, attach the fixed brackets to the rear of the device, using the screws provided.

Figure 13: Attaching the Mounting Ears and Fixed Brackets

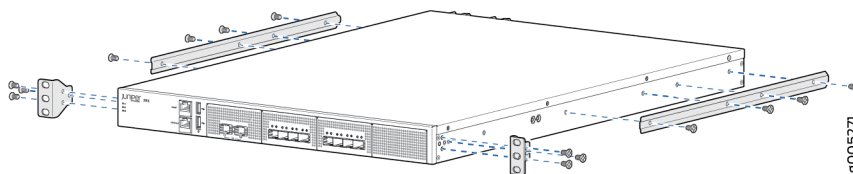

NOTE: Ensure that the rear of the device is supported throughout the process of mounting the device into the rack.

2. Slide the device into the rack, and secure the mounting ears to the rack, using the mounting screws.

Figure 14: Securing the Mounting Ears to the Rack

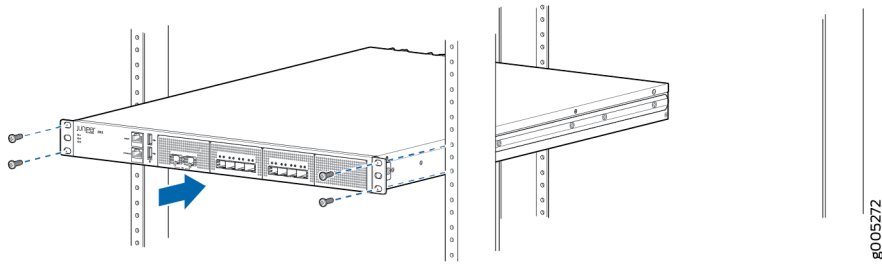

3. Slide the adjustable brackets into the fixed brackets attached to the rear of the device.

Figure 15: Attaching the Adjustable Brackets

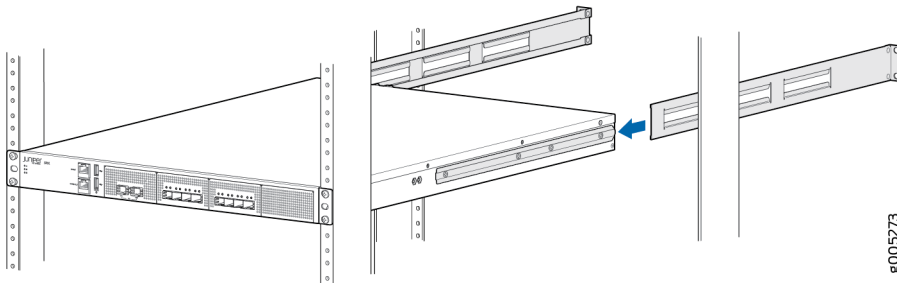

4. Secure the adjustable brackets to the rack, using the mounting screws.

Figure 16: Securing the Adjustable Brackets to the Rack

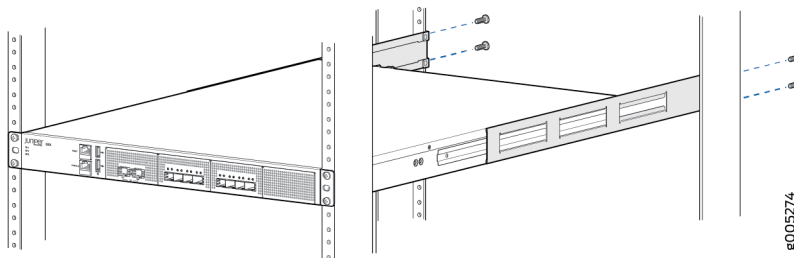

RELATED DOCUMENTATION

Configuring Junos OS on the SRX4100 | 53

Connecting the SRX4100 to Power

IN THIS SECTION

- [Connecting the SRX4100 Firewall Grounding Cable | 46](#)
- [Connecting AC Power to an SRX4100 Firewall | 47](#)
- [Connecting DC Power to an SRX4100 Firewall | 49](#)

Connecting the SRX4100 Firewall Grounding Cable

To meet safety and electromagnetic interference (EMI) requirements and to ensure proper operation, the services gateway must be adequately grounded before power is connected. You must provide a grounding lug to connect the services gateway to earth ground.

You ground the services gateway by connecting a grounding cable to earth ground and then attaching it to the chassis grounding point located on the back panel of the device using an M5 x 10 mm grounding screw.

You must install the SRX4100 in a restricted-access location and ensure that the chassis is always properly grounded. The SRX4100 has a single-hole protective grounding terminal provided on the chassis. See [Figure 17 on page 47](#). Under all circumstances, use this grounding connection to ground the chassis. For AC-powered systems, you must also use the grounding wire in the AC power cord along with the single-hole grounding lug connection. This tested system meets or exceeds all applicable EMC regulatory requirements with the single-hole protective grounding terminal.



CAUTION: Before you connect power to the services gateway, a licensed electrician must attach a cable lug to the grounding cable that you supply. A cable with an incorrectly attached lug can damage the services gateway (for example, by causing a short circuit).

Ensure that you have the following parts and tools available:

- Electrostatic discharge (ESD) grounding wrist strap
- Phillips (+) screwdriver, number 2
- 16 AWG single-strand wire grounding cable (green and yellow wire)

- Grounding lug (ring-type, vinyl-insulated TV14-6R lug, or equivalent)
- One metric M5 x 10 mm grounding screw

To connect the services gateway to earth ground:

1. Attach an electrostatic discharge (ESD) grounding strap to your bare wrist, and connect the strap to the ESD point on the chassis.
2. Connect one end of the grounding cable to a proper earth ground, such as the rack in which the services gateway is mounted.
3. Place the grounding lug attached to the grounding cable over the grounding point.
4. Secure the grounding cable lug to the grounding point with the screw. See [Figure 17 on page 47](#).

Figure 17: Connecting the Grounding Cable

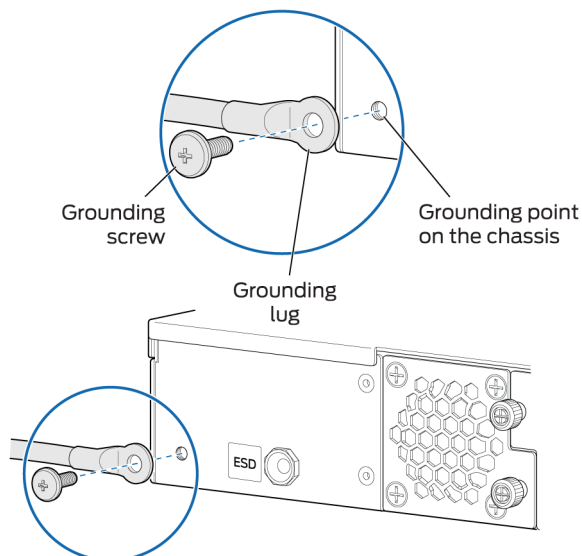

5. Dress the grounding cable and verify that it does not touch or block access to the services gateway components and that it does not drape where people could trip on it.

NOTE: When removing the chassis, turn off the power, and disconnect the grounding cable.

Connecting AC Power to an SRX4100 Firewall

Ensure that you have a power cord appropriate for your geographical location available to connect AC power to an SRX4100 Firewall. Before you begin connecting AC power:

- Ensure that you have taken the necessary precautions to prevent electrostatic discharge (ESD) damage.
- Ensure that you have connected the device chassis to earth ground.



CAUTION: Before you connect power to the services gateway, a licensed electrician must attach a cable lug to the grounding cable that you supply. A cable with an incorrectly attached lug can damage the device (for example, by causing a short circuit). To meet safety and electromagnetic interference (EMI) requirements and to ensure proper operation, you must properly ground the services gateway chassis before connecting power.

To connect AC power:

1. Attach an electrostatic discharge (ESD) grounding strap to your bare wrist, and connect the strap to the ESD point on the rear of the chassis.
2. Ensure that the power supplies are fully inserted in the chassis and the latches are secure.
3. Locate the power cords shipped with the services gateway; the cords have plugs appropriate for your geographical location.
4. Insert the coupler end of the power cord into the AC power cord inlet on the AC power supply faceplate.
5. Push the power cord retainer onto the power cord. See [Figure 18 on page 48](#).

Figure 18: Connecting AC Power

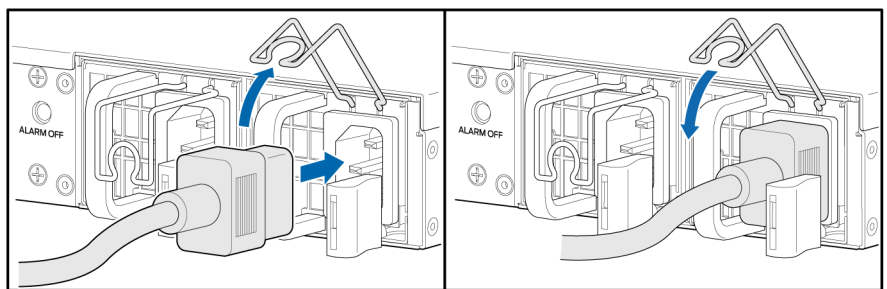

6. If the AC power source outlet has a power switch, set it to the off (O) position.
7. Insert the power cord plug into an AC power source outlet.
8. Dress the power cord appropriately. Verify that the power cord does not block the air exhaust and access to services gateway components or drape where people could trip on it.
9. If the AC power source outlet has a power switch, set it to the on (I) position.
10. Repeat steps 4 through 8 for the second AC power supply.

11. Verify that the AC and DC LEDs on each power supply are lit green. If the fault status (!) LED is lit amber, remove power from the power supply, and replace the power supply (see ["Removing an AC Power Supply from an SRX4100 Services Gateway" on page 60](#)). Do not remove the power supply until you have a replacement power supply ready. The power supplies must be installed in the services gateway to ensure proper airflow.

Connecting DC Power to an SRX4100 Firewall

Before you begin connecting DC power to an SRX4100 Firewall:

- Ensure that you have taken the necessary precautions to prevent electrostatic discharge (ESD) damage.
- Ensure that you have connected the chassis to earth ground.



CAUTION: Before you connect power to the services gateway, a licensed electrician must attach a cable lug to the grounding cable that you supply. A cable with an incorrectly attached lug can damage the device (for example, by causing a short circuit). To meet safety and electromagnetic interference (EMI) requirements and to ensure proper operation, you must properly ground the services gateway chassis before connecting power.

Ensure that you have the following parts and tools available:

- DC power source cables (14–16 AWG) with ring lug (Molex 190700069 or equivalent)
- Phillips (+) screwdriver, number 2
- Multimeter

To connect DC power:

1. Attach an electrostatic discharge (ESD) grounding strap to your bare wrist, and connect the strap to the ESD point on the rear of the chassis.
2. Verify that the DC power cables are correctly labeled before making connections to the power supply. In a typical power distribution scheme where the return is connected to chassis ground at the battery plant, you can use a multimeter to verify the resistance of the -48V and RTN DC cables to chassis ground.
 - The cable with very high resistance (indicating an open circuit) to chassis ground is negative (-) and will be installed on the **V-** (input) DC power input terminal.

- The cable with very low resistance (indicating a closed circuit) to chassis ground is positive (+) and will be installed on the **V+** (return) DC power input terminal.



CAUTION: You must ensure that power connections maintain the proper polarity. The power source cables might be labeled **(+)** and **(-)** to indicate their polarity. There is no standard color coding for DC power cables. The color coding used by the external DC power source at your site determines the color coding for the leads on the power cables that attach to the terminal studs on each power supply.

3. Ensure that the input circuit breaker is open so that the voltage across the DC power source cable leads is 0 V and that the cable leads will not become active while you are connecting DC power.
4. Install heat-shrink tubing insulation around the power cables:
 - a. Slide the tubing over the portion of the cable where it is attached to the lug barrel. Ensure that the tubing covers the end of the wire and the barrel of the lug attached to it.
 - b. Shrink the tubing with a heat gun. Ensure that you heat all sides of the tubing evenly so that it shrinks around the cable tightly.

NOTE: Do not overheat the tubing.

Figure 19 on page 51 shows how to install heat-shrink tubing.

Figure 19: How to Install Heat-Shrink Tubing

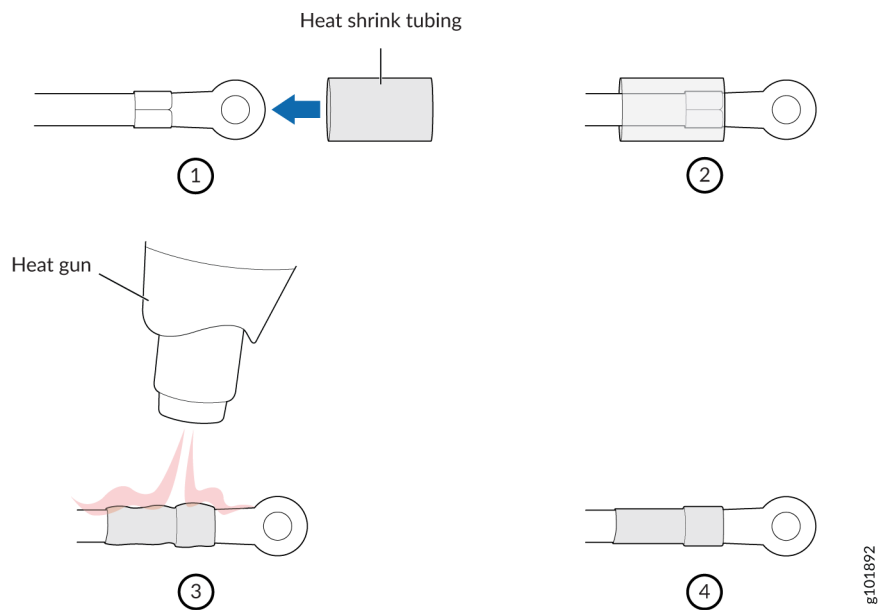

5. Remove the terminal block cover. The terminal block cover is a piece of clear plastic that snaps into place over the terminal block.
6. Remove the screws on the terminals using the screwdriver.
7. Secure each positive (+) DC source power cable lug to a RTN (return) terminal. Secure each negative (-) DC source power cable lug to a -48V (input) terminal.

Figure 20: Connecting DC Power

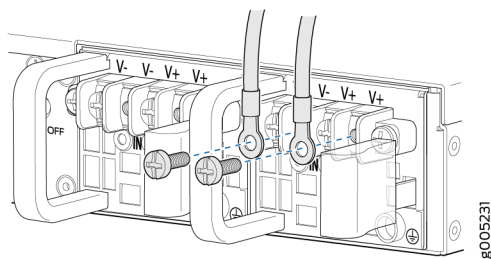

8. Tighten the screws on the power supply terminals until snug using the screwdriver. Do not overtighten.
9. Replace the terminal block cover.
10. Close the input circuit breaker.
11. The device powers on as soon as power is provided to the power supply.

12. Verify that the **IN** and **OUT** LEDs on the power supply are lit green and are on steadily.

RELATED DOCUMENTATION

| [SRX4100 Power Supply](#) | 18

Connecting the SRX4100 Firewall to a Management Console

Use the CONSOLE port on the services gateway to connect to a management console. The CONSOLE port accepts a cable that has an RJ-45 connector.

To connect the services gateway to a management console:

1. Attach an electrostatic discharge (ESD) grounding strap to your bare wrist, and connect the strap to the ESD point on the chassis.
2. Connect the RJ-45 end of the DB9-to-RJ-45 cable into the CONSOLE port on your services gateway.
3. Connect the other end of the cable to the serial port on the management device.
4. Start your asynchronous terminal emulation application (such as Microsoft Windows HyperTerminal) and select the appropriate COM port to use (for example, COM1).
5. Configure the serial port settings:
 - Baud rate—9600
 - Parity—N
 - Data bits—8
 - Stop bits—1
 - Flow control—none

Configuring Junos OS on the SRX4100

IN THIS SECTION

- [SRX4100 Firewall Software Configuration Overview | 53](#)
- [SRX4100 Firewall Factory-Default Settings | 53](#)
- [Viewing Factory-Default Settings | 54](#)
- [Configuring the SRX4100 Services Gateway | 54](#)

SRX4100 Firewall Software Configuration Overview

The services gateway is shipped with Junos OS preinstalled and ready to be configured when the services gateway is powered on. If you are setting up the services gateway for the first time, use the CLI to perform the initial configuration.

SRX4100 Firewall Factory-Default Settings

Your services gateway comes configured with a factory-default configuration.

[Table 25 on page 53](#) and [Table 26 on page 53](#) lists the factory-default settings.

Table 25: Factory-Default Settings - Interfaces

| Interface | IP Address |
|-----------|----------------|
| fxp0 | 192.168.1.1/24 |

Table 26: Factory-Default Settings - Services

| Services |
|----------|
| SSH |

Table 26: Factory-Default Settings - Services (Continued)

| |
|------------------|
| Services |
| HTTPS |
| NETCONF over SSH |

Viewing Factory-Default Settings

To view the factory-default settings on your services gateway:

1. Log in as the root user and provide your credentials.
2. View the list of default configuration files:

```
user@host>file list /etc/config
```

3. View the required default configuration file.

```
user@host> file show /etc/config/<config file name>
```

When you commit changes to the configuration, a new configuration file is created, which becomes the active configuration. If the current active configuration fails, you can use the `load factory-default` command to revert to the factory-default configuration.

Configuring the SRX4100 Services Gateway

NOTE: Before you can use J-Web to configure your services gateway, you must access the CLI to configure the root authentication.

This procedure explains how you can create an initial configuration using CLI commands to connect the services gateway to the network.

1. Connect the RJ-45 end of the DB9-to-RJ-45 cable into the CONSOLE port on your services gateway.
2. Connect the other end of the cable to the serial port on the management device.
3. Log in to the services gateway as root. When the services gateway is powered on with the factory-default configuration, you do not need to enter a password.
4. At the (%) prompt, type cli to start the CLI and press Enter. The prompt changes to an angle bracket (>) when you enter CLI operational mode.

```
root%cli
root>
```

5. At the (>) prompt, type configure and press Enter. The prompt changes from > to # when you enter configuration mode.

```
root> configure
Entering configuration mode
[edit]
root#
```

6. Set the root authentication password by entering a cleartext password, an encrypted password, or an SSH public key string (DSA or RSA).

```
[edit]
root# set system root-authentication plain-text-password
New password: password
Retype new password: password
```

7. Configure the route for the management interface (optional, required only if you do not connect the MGMT port directly to the management device).

```
[edit]
root# set routing-options static route <destination prefix> next-hop <gateway>
```

8. Commit the configuration to activate it on the services gateway.

```
[edit]
root# commit
commit complete
```

9. Connect the MGMT port on the device to the Ethernet port on the management device using an RJ-45 cable.
10. Configure an IP address on the 192.168.1.0/24 subnetwork for the management device. By default, the management interface is configured with the 192.168.1.1/24 IP address. If you need to change the IP address, perform the following steps or else proceed to [11](#).

- a. Delete the default management interface IP address:

```
root# delete interface fxp0 unit 0 family inet address 192.168.1.1/24
```

- b. Configure a new IP address for the management interface:

```
root# set interfaces fxp0 unit 0 family inet address address/prefix-length
```

- c. Commit the configuration changes.

```
root# commit
```

- d. Configure an IP address for the management device. Ensure that the IP address is on the same subnetwork as the management interface (fxp0).
11. Launch a Web browser from the management device and access the services gateway using the URL <https://192.168.1.1>.

If you changed the management interface IP address in Step [10](#), then use the URL `https://<management IP address>` to access the services gateway.

NOTE: As the system-generated certificate is not trusted by default, an alert is displayed. You can ignore this alert and proceed to access the services gateway.

The J-Web login page is displayed. This indicates that you have successfully completed the initial configuration and that your services gateway is ready for use.

NOTE: To access the J-Web interface, your management device requires one of the following supported browsers:

- Microsoft Internet Explorer version 9.0 or 10.0

- Mozilla Firefox version 38 (or later)

12. Log in as root and proceed with configuring the settings based on your requirements.

5

CHAPTER

Maintaining Components

Routine Maintenance Procedures for the SRX4100 | 59

Maintaining the SRX4100 Power System | 59

Maintaining the SRX4100 Cooling System | 64

Routine Maintenance Procedures for the SRX4100

For optimum performance of the services gateway, perform the following preventive maintenance procedures regularly:

- Inspect the installation site for moisture, loose wires or cables, and excessive dust.
- Make sure that airflow is unobstructed around the services gateway and into the air intake vents. Make sure that all power and grounding cables are arranged so that they do not obstruct access to other services gateway components.
- Check the status LEDs on the front panel of the services gateway.
- Periodically inspect the site to ensure that the grounding and power cables connected to the services gateway are securely in place and that there is no moisture accumulating near the services gateway.

RELATED DOCUMENTATION

[Troubleshooting Resources for the SRX4100 Services Gateway | 67](#)

[Monitoring Chassis Alarms on an SRX4100 Services Gateway | 67](#)

Maintaining the SRX4100 Power System

IN THIS SECTION

- [Replacing an AC Power Supply on the SRX4100 | 60](#)
- [Replacing a DC Power Supply on the SRX4100 | 62](#)

Replacing an AC Power Supply on the SRX4100

IN THIS SECTION

- [Removing an AC Power Supply from an SRX4100 Services Gateway | 60](#)
- [Installing an AC Power Supply in an SRX4100 Services Gateway | 61](#)

The power supplies are hot-removable and hot-insertable field-replaceable units (FRUs) installed in the rear panel of the services gateway. You can remove and replace them without powering off the services gateway or disrupting services gateway functions.

Ensure that you have the following parts and tools available:

- ESD grounding strap
- Antistatic bag or an antistatic mat
- Replacement power supply

Removing an AC Power Supply from an SRX4100 Services Gateway

To remove a power supply from the services gateway (see [Figure 21 on page 61](#)):

1. Place the antistatic bag or the antistatic mat on a flat, stable surface.
2. Attach an electrostatic discharge (ESD) grounding strap to your bare wrist and connect the strap to the ESD point on the chassis.
3. If the AC power source outlet has a power switch, set it to the off (0) position and pull out the power cord connected to the power source outlet.
4. Remove the power cord from the power supply faceplate.
5. Slide the ejector lever toward the left until the power supply is unseated.
6. Grasp the power supply handle and pull firmly to slide the power supply halfway out of the chassis.
7. Place one hand under the power supply to support it and slide it completely out of the chassis. Take care not to touch power supply components, pins, leads, or solder connections.

Figure 21: Removing an AC Power Supply

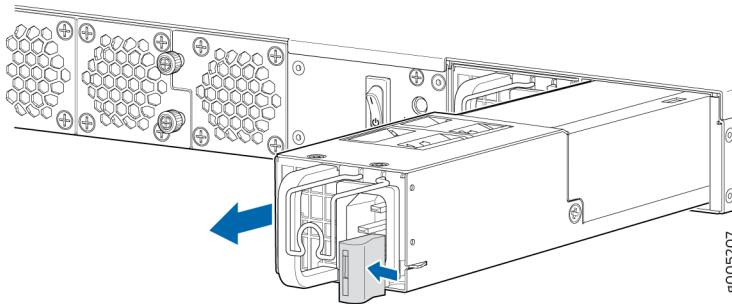

8. Place the power supply in the antistatic bag or on the antistatic mat placed on a flat, stable surface.

Installing an AC Power Supply in an SRX4100 Services Gateway



CAUTION: Do not mix AC and DC power supplies in the same chassis.

To install an AC power supply (see [Figure 22 on page 62](#)):

1. Attach the ESD grounding strap to your bare wrist, and connect the strap to the ESD point on the chassis.
2. If the power supply slot has a cover panel on it, with one hand slide the ejector lever toward the left until it stops and using the other hand pull the handle of the cover panel outward to remove it. Save the cover panel for later use.
3. Taking care not to touch power supply pins, leads, or solder connections, remove the power supply from the bag.
4. Using both hands, place the power supply in the power supply slot on the rear panel of the services gateway and slide it in until it is fully seated and the ejector lever fits into place. You will hear a distinct click when the power supply is fully seated in the chassis.

Figure 22: Installing an AC Power Supply

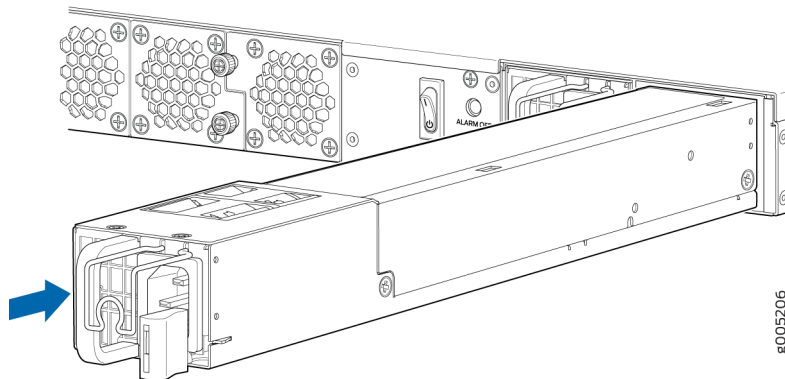

SEE ALSO

[Connecting AC Power to an SRX4100 Firewall | 47](#)

Replacing a DC Power Supply on the SRX4100

IN THIS SECTION

- [Removing a DC Power Supply from an SRX4100 Services Gateway | 63](#)
- [Installing a DC Power Supply in an SRX4100 Services Gateway | 63](#)

The power supplies are hot-removable and hot-insertable field-replaceable units (FRUs) installed in the rear panel of the services gateway. You can remove and replace them without powering off the services gateway or disrupting services gateway functions.

Ensure that you have the following parts and tools available:

- ESD grounding strap
- Phillips (+) screwdriver, number 2
- Antistatic bag or an antistatic mat
- Replacement power supply

Removing a DC Power Supply from an SRX4100 Services Gateway

To remove a DC power supply (see [Figure 23 on page 63](#)):

1. Place the antistatic bag or the antistatic mat on a flat, stable surface.
2. Attach the ESD grounding strap to your bare wrist, and connect the strap to the ESD point on the chassis.
3. Make sure that the voltage across the DC power source cables leads is 0 V and that there is no chance that the cables might become active during the removal process.
4. Remove the plastic cover from the input terminals by sliding the cover either to the left or right.
5. Unscrew the locking screws counterclockwise by using the screwdriver.
6. Remove the cable lugs from the input DC terminals.
7. Slide the ejector lever toward the left until the power supply is unseated.
8. Grasp the power supply handle and pull firmly to slide the power supply halfway out of the chassis.
9. Taking care not to touch power supply pins, leads, or solder connections, place one hand under the power supply to support it. Grasp the power supply handle with your other hand and pull the power supply completely out of the chassis.

Figure 23: Removing a DC Power Supply

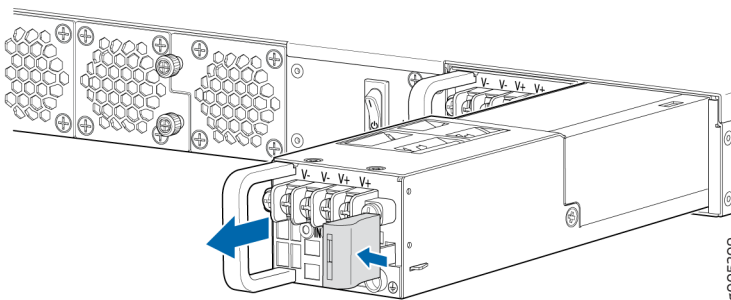

10. Place the power supply in the antistatic bag or on the antistatic mat placed on a flat, stable surface.

Installing a DC Power Supply in an SRX4100 Services Gateway



CAUTION: Do not mix AC and DC power supplies in the same chassis.

To install a DC power supply (see [Figure 24 on page 64](#)):

1. Attach the ESD grounding strap to your bare wrist, and connect the strap to the ESD point on the chassis.

2. Taking care not to touch power supply pins, leads, or solder connections, remove the power supply from the bag.
3. Using both hands, place the power supply in the power supply slot on the rear panel of the services gateway and slide it in until it is fully seated and the ejector lever fits into place. You will hear a distinct click when the power supply is fully seated in the chassis.

Figure 24: Installing a DC Power Supply

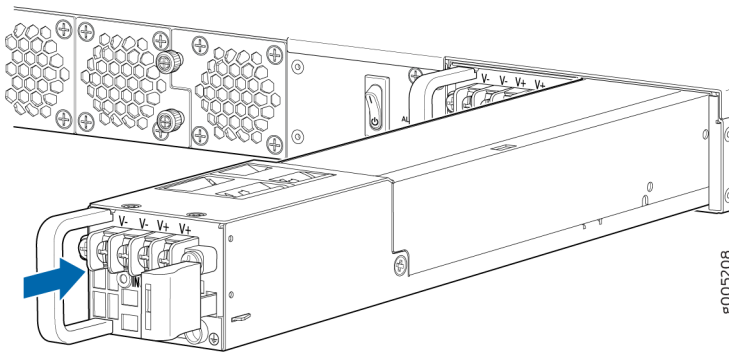

SEE ALSO

[Connecting DC Power to an SRX4100 Firewall | 49](#)

Maintaining the SRX4100 Cooling System

IN THIS SECTION

- [Replacing the SRX4100 Firewall Fan Tray | 64](#)

Replacing the SRX4100 Firewall Fan Tray

To replace the fan tray:

1. Identify the physical location of the faulty fan tray on the rear panel of the chassis. [Figure 25 on page 65](#) shows how the fan trays are numbered.

Figure 25: SRX4100 Firewall Fan Tray Numbering

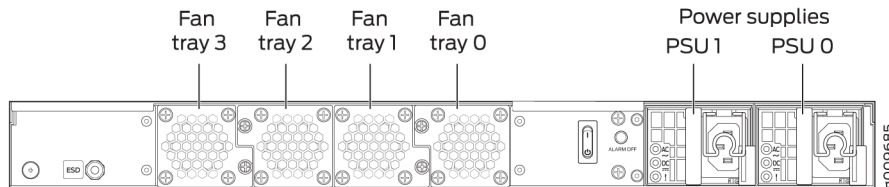

2. Attach an electrostatic discharge (ESD) grounding strap to your bare wrist, and connect the strap to the ESD point on the chassis.
3. Loosen the captive screws on the fan tray faceplate.
4. Grasp the captive screw and pull out the fan tray completely out of the chassis.
5. Insert the replacement fan tray straight into the chassis.
6. Tighten the captive screw on the fan tray faceplate to secure it in the chassis.

RELATED DOCUMENTATION

| [SRX4100 Cooling System](#) | 16

6

CHAPTER

Troubleshooting Hardware

[Troubleshooting the SRX4100](#) | 67

Troubleshooting the SRX4100

IN THIS SECTION

- [Troubleshooting Resources for the SRX4100 Services Gateway | 67](#)
- [Monitoring Chassis Alarms on an SRX4100 Services Gateway | 67](#)
- [Using the RESET Button on the SRX4100 Services Gateway | 69](#)

Troubleshooting Resources for the SRX4100 Services Gateway

To troubleshoot a services gateway, use the Junos OS command-line interface (CLI) and LEDs on the chassis:

- LEDs—When the services gateway detects an alarm condition, the status LED on the front panel glows red.
- CLI—The CLI is the primary tool for controlling and troubleshooting hardware, Junos OS, and network connectivity. Use the CLI to display more information about alarms. CLI commands display information about network connectivity derived from the ping and traceroute utilities. For information about using the CLI to troubleshoot Junos OS, see the appropriate Junos OS configuration guide.
- JTAC—If you need assistance during troubleshooting, you can contact the Juniper Networks Technical Assistance Center (JTAC) by using the Web or by telephone. If you encounter software problems, or problems with hardware components not discussed here, contact JTAC.

Monitoring Chassis Alarms on an SRX4100 Services Gateway

You can monitor chassis alarms through the Status LED. When the services gateway detects an alarm condition, the Status LED on the front panel glows red. The level of severity can be either major (steady red) or minor (blinking red). To view a more detailed description of the alarm cause, issue the `show chassis alarms` command.

[Table 27 on page 68](#) describes alarms that can occur for the services gateway chassis component.

Table 27: Alarms for Services Gateway Chassis Components

| Component | Alarm Conditions | Action | Alarm Severity |
|--------------|---|--|--------------------|
| Fan | At least one of the fans have failed. | <ul style="list-style-type: none"> • Check and adjust the room temperature, if possible. • Check the air flow and ensure that the airflow through the services gateway is unobstructed. • Open a support case using the Case Manager link at https://www.juniper.net/support/ or call 1-888-314-5822 (toll-free within the United States and Canada) or 1-408-745-9500 (from outside the United States). | Steady red (major) |
| | The services gateway chassis temperature is too warm. | <ul style="list-style-type: none"> • Check the room temperature. • Check the air flow. • Open a support case using the Case Manager link at https://www.juniper.net/support/ or call 1-888-314-5822 (toll-free within the United States and Canada) or 1-408-745-9500 (from outside the United States). | Yellow (minor) |
| Power supply | A power supply has failed. | Replace the power supply. | Steady red (major) |

Table 27: Alarms for Services Gateway Chassis Components (Continued)

| Component | Alarm Conditions | Action | Alarm Severity |
|-----------|-------------------------------------|--|----------------|
| | A power supply unit is not present. | Install a power supply unit in the empty slot. The services gateway requires two power supply units to be installed. | |
| | AC power cord is not connected. | Verify and ensure that the AC power cord is connected properly. | |

Using the RESET Button on the SRX4100 Services Gateway

If a configuration fails or denies management access to the services gateway, you can use the RESET button to restore the services gateway to the factory-default configuration.



CAUTION: Pressing and holding the RESET button for 5 seconds or more deletes all configurations (backup configurations and rescue configuration) on the device, and loads and commits the factory configuration.

You can change the default operation of the RESET button by limiting how the button resets the services gateway:

- To prevent the RESET button from setting the services gateway to the factory-default configuration and deleting all other configurations, enter the following command. You can still press and quickly release the button to reset it to the rescue configuration.

```
user@host# set chassis config-button no-clear
```

- To prevent the RESET button from setting the services gateway to the rescue configuration, enter the following command. You can still press and hold the button for 15 seconds or more to reset the services gateway to the factory-default configuration.

```
user@host# set chassis config-button no-rescue
```

- To disable the button and prevent the services gateway from resetting to either configuration, enter the following command:

```
user@host# set chassis config-button no-clear no-rescue
```

The `no-rescue` option prevents the RESET button from loading the rescue configuration. The `no-clear` option prevents the RESET button from deleting all configurations on the services gateway.

To return the function of the RESET button to its default behavior, remove the `config-button` statement from the services gateway configuration.

RELATED DOCUMENTATION

| [SRX4100 Firewall Front Panel](#) | 10

7

CHAPTER

Contacting Customer Support and Returning the Chassis or Components

[Returning the SRX4100 Chassis or Components | 72](#)

Returning the SRX4100 Chassis or Components

IN THIS SECTION

- [Contacting Customer Support | 72](#)
- [Returning a SRX4100 Firewall or Component to Juniper Networks | 73](#)
- [Locating the Serial Number on the SRX4100 Firewall or Component | 73](#)
- [Packing a SRX4100 Firewall or Component for Shipping | 75](#)

Contacting Customer Support

Once you have located the serial numbers of the device or component, you can return the device or component for repair or replacement. For this, you need to contact Juniper Networks Technical Assistance Center (JTAC).

You can contact JTAC 24 hours a day, 7 days a week, using any of the following methods:

- On the Web: Using the Service Request Manager link at <https://support.juniper.net/support/>
- By telephone:
 - From the US and Canada: 1-888-314-JTAC
 - From all other locations: 1-408-745-9500

NOTE: If contacting JTAC by telephone, enter your 12-digit service request number followed by the pound (#) key if this is an existing case, or press the star (*) key to be routed to the next available support engineer.

When requesting support from JTAC by telephone, be prepared to provide the following information:

- Your existing service request number, if you have one
- Details of the failure or problem
- Type of activity being performed on the firewall when the problem occurred
- Configuration data displayed by one or more `show` commands

- Your name, organization name, telephone number, fax number, and shipping address

The support representative validates your request and issues a Return Materials Authorization (RMA) number for return of the device or component.

Returning a SRX4100 Firewall or Component to Juniper Networks

To return a services gateway or component to Juniper Networks for repair or replacement, follow this procedure:

1. Determine the part number and serial number of the services gateway or component. See "[Locating the Serial Number on the SRX4100 Services Gateway or Component](#)" on page 73.
2. Obtain a Return Materials Authorization (RMA) number from JTAC. See *Contacting Customer Support*.

NOTE: Do not return the services gateway or any component to Juniper Networks unless you have first obtained an RMA number. Juniper Networks reserves the right to refuse shipments that do not have an RMA. Refused shipments are returned to the customer via collect freight.

3. Pack the services gateway or component for shipping.

For more information about return and repair policies, see the customer support webpage at <https://www.juniper.net/support/guidelines.html>.

For product problems or technical support issues, open a support case using the Case Manager link at <https://www.juniper.net/support/> or call 1-888-314-JTAC (within the United States) or 1-408-745-9500 (outside the United States).

Locating the Serial Number on the SRX4100 Firewall or Component

IN THIS SECTION

- [Listing the SRX4100 Firewall Component Details with the CLI | 74](#)
- [Locating the Chassis Serial Number ID Label | 75](#)
- [Locating the Serial Number ID Labels on FRUs | 75](#)

Locating the Chassis Serial Number ID Label

The serial number ID label is located on the rear panel of the services gateway.

Locating the Serial Number ID Labels on FRUs

The power supplies installed in the services gateway are field-replaceable units (FRUs). The serial number ID label is on the top of the power supply.

Packing a SRX4100 Firewall or Component for Shipping

IN THIS SECTION

- [Packing the SRX4100 Firewall for Shipment | 75](#)
- [Packing the SRX4100 Firewall Components for Shipment | 76](#)

Before you pack a SRX4100 Firewall or component:

- Ensure that you have taken the necessary precautions to prevent electrostatic discharge (ESD) damage.
- Retrieve the original shipping carton and packing materials. Contact your JTAC representative if you do not have these materials, to learn about approved packing materials. See *Contacting Customer Support*.

Ensure that you have the following parts and tools available:

- ESD grounding strap
- Antistatic bag, one for each component
- Phillips (+) screwdriver, number 2

Packing the SRX4100 Firewall for Shipment

To pack the services gateway for shipment:

1. Attach an electrostatic discharge (ESD) grounding strap to your bare wrist and connect the strap to the ESD point on the chassis or to an outside ESD point if the device is disconnected from earth ground. .
2. On the console or other management device connected to the services gateway, enter CLI operational mode and issue the following command to shut down the services gateway software:

```
user@host> request system halt
```

Wait until a message appears on the console confirming that the operating system has halted.
3. Shut down power to the services gateway by pressing the Power switch on the rear of the services gateway.
4. Disconnect power from the services gateway.
5. Remove the cables that connect to all external devices.
6. If the services gateway is installed in a rack, have one person support the weight of the services gateway while another person unscrews and removes the mounting screws.
7. Place the services gateway in the shipping carton.
8. Cover the services gateway with an ESD bag, and place the packing foam on top of and around the device.
9. Replace the accessory box on top of the packing foam.
10. Securely tape the box closed.
11. Write the Return Materials Authorization (RMA) number on the exterior of the box to ensure proper tracking.

Packing the SRX4100 Firewall Components for Shipment

Follow these guidelines for packing and shipping individual components of the services gateway:

- When you return a component, make sure that it is adequately protected with packing materials and packed so that the pieces are prevented from moving around inside the carton.
- Use the original shipping materials if they are available.
- Place the individual component in an electrostatic bag.
- Write the Return Materials Authorization (RMA) number on the exterior of the box to ensure proper tracking.



CAUTION: Do not stack any of the services gateway components during packing.



CHAPTER

Safety and Compliance Information

| |
|---|
| General Safety Guidelines and Warnings 79 |
| Definitions of Safety Warning Levels 80 |
| Restricted Access Area Warnings 82 |
| Qualified Personnel Warning 83 |
| Prevention of Electrostatic Discharge Damage 84 |
| Fire Safety Requirements 85 |
| Laser and LED Safety Guidelines and Warnings 87 |
| Radiation from Open Port Apertures Warning 90 |
| Maintenance and Operational Safety Guidelines and Warnings 91 |
| General Electrical Safety Guidelines and Warnings 97 |
| AC Power Electrical Safety Guidelines 102 |
| DC Power Electrical Safety Guidelines 103 |
| DC Power Disconnection Warning 104 |
| DC Power Grounding Requirements and Warning 106 |
| DC Power Wiring Sequence Warning 107 |
| DC Power Wiring Terminations Warning 108 |
| Action to Take After an Electrical Accident 109 |
| Agency Approvals 110 |
| Acoustic Noise Compliance Statements 112 |
| EMC Requirements 112 |

General Safety Guidelines and Warnings

The following guidelines help ensure your safety and protect the device from damage. The list of guidelines might not address all potentially hazardous situations in your working environment, so be alert and exercise good judgment at all times.

- Perform only the procedures explicitly described in the hardware documentation for this device. Make sure that only authorized service personnel perform other system services.
- Keep the area around the device clear and free from dust before, during, and after installation.
- Keep tools away from areas where people could trip over them while walking.
- Do not wear loose clothing or jewelry, such as rings, bracelets, or chains, which could become caught in the device.
- Wear safety glasses if you are working under any conditions that could be hazardous to your eyes.
- Do not perform any actions that create a potential hazard to people or make the equipment unsafe.
- Never attempt to lift an object that is too heavy for one person to handle.
- Never install or manipulate wiring during electrical storms.
- Never install electrical jacks in wet locations unless the jacks are specifically designed for wet environments.
- Operate the device only when it is properly grounded.
- Follow the instructions in this guide to properly ground the device to earth.
- Replace fuses only with fuses of the same type and rating.
- Do not open or remove chassis covers or sheet-metal parts unless instructions are provided in the hardware documentation for this device. Such an action could cause severe electrical shock.
- Do not push or force any objects through any opening in the chassis frame. Such an action could result in electrical shock or fire.
- Avoid spilling liquid onto the chassis or onto any device component. Such an action could cause electrical shock or damage the device.
- Avoid touching uninsulated electrical wires or terminals that have not been disconnected from their power source. Such an action could cause electrical shock.

- Some parts of the chassis, including AC and DC power supply surfaces, power supply unit handles, SFB card handles, and fan tray handles might become hot. The following label provides the warning for hot surfaces on the chassis:



- Always ensure that all modules, power supplies, and cover panels are fully inserted and that the installation screws are fully tightened.

Definitions of Safety Warning Levels

The documentation uses the following levels of safety warnings (there are two *Warning* formats):

NOTE: You might find this information helpful in a particular situation, or you might overlook this important information if it was not highlighted in a Note.



CAUTION: You need to observe the specified guidelines to prevent minor injury or discomfort to you or severe damage to the device.

Attention Veillez à respecter les consignes indiquées pour éviter toute incommodité ou blessure légère, voire des dégâts graves pour l'appareil.



LASER WARNING: This symbol alerts you to the risk of personal injury from a laser.

Avertissement Ce symbole signale un risque de blessure provoquée par rayon laser.



WARNING: This symbol means danger. You are in a situation that could cause bodily injury. Before you work on any equipment, be aware of the hazards involved with electrical circuitry, and familiarize yourself with standard practices for preventing accidents.

Waarschuwing Dit waarschuwingssymbool betekent gevaar. U verkeert in een situatie die lichamelijk letsel kan veroorzaken. Voordat u aan enige apparatuur gaat werken, dient u zich bewust te zijn van de bij elektrische schakelingen betrokken risico's en dient u op de hoogte te zijn van standaard maatregelen om ongelukken te voorkomen.

Varoitus Tämä varoitusmerkki merkitsee vaaraa. Olet tilanteessa, joka voi johtaa ruumiinvammaan. Ennen kuin työskentelet minkään laitteiston parissa, ota selvää sähkökytkentöihin liittyvistä vaaroista ja tavanomaisista onnettomuuksien ehkäisykeinoista.

Avertissement Ce symbole d'avertissement indique un danger. Vous vous trouvez dans une situation pouvant causer des blessures ou des dommages corporels. Avant de travailler sur un équipement, soyez conscient des dangers posés par les circuits électriques et familiarisez-vous avec les procédures couramment utilisées pour éviter les accidents.

Warnung Dieses Warnsymbol bedeutet Gefahr. Sie befinden sich in einer Situation, die zu einer Körperverletzung führen könnte. Bevor Sie mit der Arbeit an irgendeinem Gerät beginnen, seien Sie sich der mit elektrischen Stromkreisen verbundenen Gefahren und der Standardpraktiken zur Vermeidung von Unfällen bewußt.

Avvertenza Questo simbolo di avvertenza indica un pericolo. La situazione potrebbe causare infortuni alle persone. Prima di lavorare su qualsiasi apparecchiatura, occorre conoscere i pericoli relativi ai circuiti elettrici ed essere al corrente delle pratiche standard per la prevenzione di incidenti.

Advarsel Dette varselsymbolet betyr fare. Du befinner deg i en situasjon som kan føre til personskade. Før du utfører arbeid på utstyr, må du være oppmerksom på de faremomentene som elektriske kretser innebærer, samt gjøre deg kjent med vanlig praksis når det gjelder å unngå ulykker.

Aviso Este símbolo de aviso indica perigo. Encontra-se numa situação que lhe poderá causar danos físicos. Antes de começar a trabalhar com qualquer equipamento, familiarize-se com os perigos relacionados com circuitos eléctricos, e com quaisquer práticas comuns que possam prevenir possíveis acidentes.

¡Atención! Este símbolo de aviso significa peligro. Existe riesgo para su integridad física. Antes de manipular cualquier equipo, considerar los riesgos que entraña la corriente eléctrica y familiarizarse con los procedimientos estándar de prevención de accidentes.

Varning! Denna varningssymbol signalerar fara. Du befinner dig i en situation som kan leda till personskada. Innan du utför arbete på någon utrustning måste du vara medveten om farorna med elkretsar och känna till vanligt förfarande för att förebygga skador.

Restricted Access Area Warnings



WARNING: The services gateway is intended for installation in restricted access areas. A restricted access area is an area to which access can be gained only by service personnel through the use of a special tool, lock and key, or other means of security, and which is controlled by the authority responsible for the location.

Waarschuwing Dit toestel is bedoeld voor installatie op plaatsen met beperkte toegang. Een plaats met beperkte toegang is een plaats waar toegang slechts door servicepersoneel verkregen kan worden door middel van een speciaal instrument, een slot en sleutel, of een ander veiligheidsmiddel, en welke beheerd wordt door de overheidsinstantie die verantwoordelijk is voor de locatie.

Varoitus Tämä laite on tarkoitettu asennettavaksi paikkaan, johon pääsy on rajoitettua. Paikka, johon pääsy on rajoitettua, tarkoittaa paikkaa, johon vain huoltohenkilöstö pääsee jonkin erikoistyökalun, lukkoon sopivan avaimen tai jonkin muun turvalaitteen avulla ja joka on paikasta vastuussa olevien toimivaltaisten henkilöiden valvoma.

Attention Cet appareil est à installer dans des zones d'accès réservé. Ces dernières sont des zones auxquelles seul le personnel de service peut accéder en utilisant un outil spécial, un mécanisme de verrouillage et une clé, ou tout autre moyen de sécurité. L'accès aux zones de sécurité est sous le contrôle de l'autorité responsable de l'emplacement.

Warnung Diese Einheit ist zur Installation in Bereichen mit beschränktem Zutritt vorgesehen. Ein Bereich mit beschränktem Zutritt ist ein Bereich, zu dem nur Wartungspersonal mit einem Spezialwerkzeugs, Schloß und Schlüssel oder anderer Sicherheitsvorkehrungen Zugang hat, und der von dem für die Anlage zuständigen Gremium kontrolliert wird.

Avvertenza Questa unità deve essere installata in un'area ad accesso limitato. Un'area ad accesso limitato è un'area accessibile solo a personale di assistenza tramite un'attrezzo speciale, lucchetto, o altri dispositivi di sicurezza, ed è controllata dall'autorità responsabile della zona.

Advarsel Denne enheten er laget for installasjon i områder med begrenset adgang. Et område med begrenset adgang gir kun adgang til servicepersonale som bruker et spesielt verktøy, lås og nøkkel, eller en annen sikkerhetsanordning, og det kontrolleres av den autoriteten som er ansvarlig for området.

Aviso Esta unidade foi concebida para instalação em áreas de acesso restrito. Uma área de acesso restrito é uma área à qual apenas tem acesso o pessoal de serviço autorizado,

que possua uma ferramenta, chave e fechadura especial, ou qualquer outra forma de segurança. Esta área é controlada pela autoridade responsável pelo local.

¡Atención! Esta unidad ha sido diseñada para instalarse en áreas de acceso restringido. Área de acceso restringido significa un área a la que solamente tiene acceso el personal de servicio mediante la utilización de una herramienta especial, cerradura con llave, o algún otro medio de seguridad, y que está bajo el control de la autoridad responsable del local.

Warning! Denna enhet är avsedd för installation i områden med begränsat tillträde. Ett område med begränsat tillträde får endast tillträdas av servicepersonal med ett speciellt verktyg, lås och nyckel, eller annan säkerhetsanordning, och kontrolleras av den auktoritet som ansvarar för området.

RELATED DOCUMENTATION

| *Qualified Personnel Warning*

Qualified Personnel Warning



WARNING: Only trained and qualified personnel should install or replace the device.

Waarschuwing Installatie en reparaties mogen uitsluitend door getraind en bevoegd personeel uitgevoerd worden.

Varoitus Ainoastaan koulutettu ja pätevä henkilökunta saa asentaa tai vaihtaa tämän laitteen.

Avertissement Tout installation ou remplacement de l'appareil doit être réalisé par du personnel qualifié et compétent.

Warnung Gerät nur von geschultem, qualifiziertem Personal installieren oder auswechseln lassen.

Avvertenza Solo personale addestrato e qualificato deve essere autorizzato ad installare o sostituire questo apparecchio.

Advarsel Kun kvalifisert personell med riktig opplæring bør montere eller bytte ut dette utstyret.

Aviso Este equipamento deverá ser instalado ou substituído apenas por pessoal devidamente treinado e qualificado.

¡Atención! Estos equipos deben ser instalados y reemplazados exclusivamente por personal técnico adecuadamente preparado y capacitado.

Varning! Denna utrustning ska endast installeras och bytas ut av utbildad och kvalificerad personal.

Prevention of Electrostatic Discharge Damage

Device components that are shipped in antistatic bags are sensitive to damage from static electricity. Some components can be impaired by voltages as low as 30 V. You can easily generate potentially damaging static voltages whenever you handle plastic or foam packing material or if you move components across plastic or carpets. Observe the following guidelines to minimize the potential for electrostatic discharge (ESD) damage, which can cause intermittent or complete component failures:

- Always use an ESD wrist strap when you are handling components that are subject to ESD damage, and make sure that it is in direct contact with your skin.

If a grounding strap is not available, hold the component in its antistatic bag (see [Figure 26 on page 85](#)) in one hand and touch the exposed, bare metal of the device with the other hand immediately before inserting the component into the device.



WARNING: For safety, periodically check the resistance value of the ESD grounding strap. The measurement must be in the range 1 through 10 Mohms.

Avertissement Par mesure de sécurité, vérifiez régulièrement la résistance du bracelet antistatique. Cette valeur doit être comprise entre 1 et 10 mégohms (Mohms).

- When handling any component that is subject to ESD damage and that is removed from the device, make sure the equipment end of your ESD wrist strap is attached to the ESD point on the chassis.

If no grounding strap is available, touch the exposed, bare metal of the device to ground yourself before handling the component.

- Avoid contact between the component that is subject to ESD damage and your clothing. ESD voltages emitted from clothing can damage components.

- When removing or installing a component that is subject to ESD damage, always place it component-side up on an antistatic surface, in an antistatic card rack, or in an antistatic bag (see [Figure 26 on page 85](#)). If you are returning a component, place it in an antistatic bag before packing it.

Figure 26: Placing a Component into an Antistatic Bag

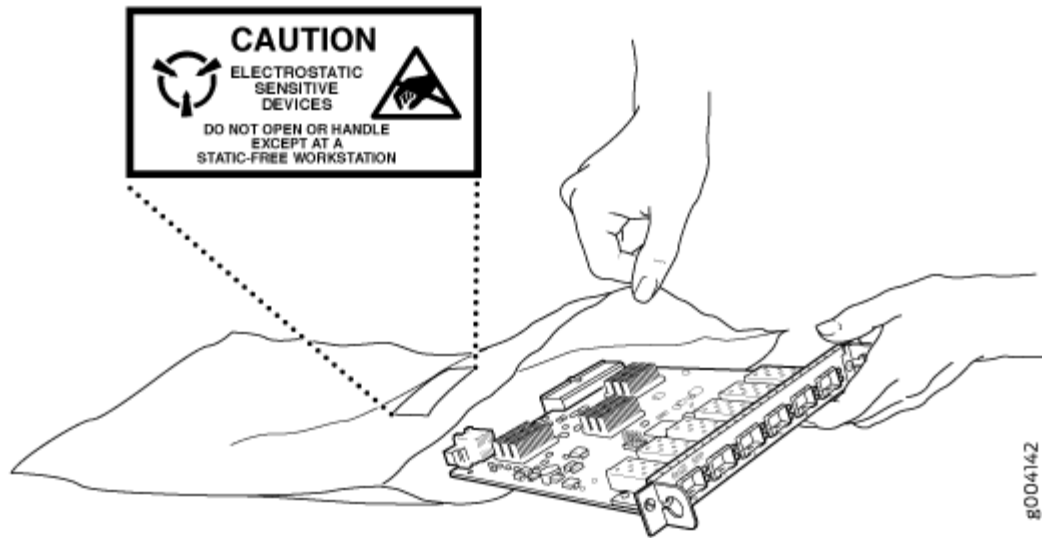

CAUTION: ANSI/TIA/EIA-568 cables such as Category 5e and Category 6 can get electrostatically charged. To dissipate this charge, always ground the cables to a suitable and safe earth ground before connecting them to the system.

Attention Les câbles ANSI/TIA/EIA-568, par exemple Cat 5e et Cat 6, peuvent emmagasiner des charges électrostatiques. Pour évacuer ces charges, reliez toujours les câbles à une prise de terre adaptée avant de les raccorder au système.

Fire Safety Requirements

IN THIS SECTION

- [Fire Suppression | 86](#)

- Fire Suppression Equipment | 86

In the event of a fire emergency, the safety of people is the primary concern. You should establish procedures for protecting people in the event of a fire emergency, provide safety training, and properly provision fire-control equipment and fire extinguishers.

In addition, you should establish procedures to protect your equipment in the event of a fire emergency. Juniper Networks products should be installed in an environment suitable for electronic equipment. We recommend that fire suppression equipment be available in the event of a fire in the vicinity of the equipment and that all local fire, safety, and electrical codes and ordinances be observed when you install and operate your equipment.

Fire Suppression

In the event of an electrical hazard or an electrical fire, you should first turn power off to the equipment at the source. Then use a Type C fire extinguisher, which uses noncorrosive fire retardants, to extinguish the fire.

Fire Suppression Equipment

Type C fire extinguishers, which use noncorrosive fire retardants such as carbon dioxide and Halotron™, are most effective for suppressing electrical fires. Type C fire extinguishers displace oxygen from the point of combustion to eliminate the fire. For extinguishing fire on or around equipment that draws air from the environment for cooling, you should use this type of inert oxygen displacement extinguisher instead of an extinguisher that leaves residues on equipment.

Do not use multipurpose Type ABC chemical fire extinguishers (dry chemical fire extinguishers). The primary ingredient in these fire extinguishers is monoammonium phosphate, which is very sticky and difficult to clean. In addition, in the presence of minute amounts of moisture, monoammonium phosphate can become highly corrosive and corrodes most metals.

Any equipment in a room in which a chemical fire extinguisher has been discharged is subject to premature failure and unreliable operation. The equipment is considered to be irreparably damaged.

NOTE: To keep warranties effective, do not use a dry chemical fire extinguisher to control a fire at or near a Juniper Networks device. If a dry chemical fire extinguisher is used, the unit is no longer eligible for coverage under a service agreement.

We recommend that you dispose of any irreparably damaged equipment in an environmentally responsible manner.

Laser and LED Safety Guidelines and Warnings

IN THIS SECTION

- [General Laser Safety Guidelines | 87](#)
- [Class 1 Laser Product Warning | 88](#)
- [Class 1 LED Product Warning | 88](#)
- [Laser Beam Warning | 89](#)

Juniper Networks devices are equipped with laser transmitters, which are considered a Class 1 Laser Product by the U.S. Food and Drug Administration and are evaluated as a Class 1 Laser Product per IEC/EN 60825-1 requirements.

Observe the following guidelines and warnings:

General Laser Safety Guidelines

When working around ports that support optical transceivers, observe the following safety guidelines to prevent eye injury:

- Do not look into unterminated ports or at fibers that connect to unknown sources.
- Do not examine unterminated optical ports with optical instruments.
- Avoid direct exposure to the beam.



LASER WARNING: Unterminated optical connectors can emit invisible laser radiation. The lens in the human eye focuses all the laser power on the retina, so focusing the eye directly on a laser source—even a low-power laser—could permanently damage the eye.

Avertissement Les connecteurs à fibre optique sans terminaison peuvent émettre un rayonnement laser invisible. Le cristallin de l'œil humain faisant converger toute la puissance du laser sur la rétine, toute focalisation directe de l'œil sur une source laser, —même de faible puissance—, peut entraîner des lésions oculaires irréversibles.

Class 1 Laser Product Warning



LASER WARNING: Class 1 laser product.

Waarschuwing Klasse-1 laser produkt.

Varoitus Luokan 1 lasertuote.

Avertissement Produit laser de classe I.

Warnung Laserprodukt der Klasse 1.

Avvertenza Prodotto laser di Classe 1.

Advarsel Laserprodukt av klasse 1.

Aviso Produto laser de classe 1.

¡Atención! Producto láser Clase I.

Varning! Laserprodukt av klass 1.

Class 1 LED Product Warning



LASER WARNING: Class 1 LED product.

Waarschuwing Klasse 1 LED-product.

Varoitus Luokan 1 valodiodituote.

Avertissement Alarme de produit LED Class I.

Warnung Class 1 LED-Produktwarnung.

Avvertenza Avvertenza prodotto LED di Classe 1.

Advarsel LED-produkt i klasse 1.

Aviso Produto de classe 1 com LED.

¡Atención! Aviso sobre producto LED de Clase 1.

Varning! Lysdiodprodukt av klass 1.

Laser Beam Warning



LASER WARNING: Do not stare into the laser beam or view it directly with optical instruments.

Waarschuwing Niet in de straal staren of hem rechtstreeks bekijken met optische instrumenten.

Varoitus Älä katso säteeseen äläkä tarkastele sitä suoraan optisen laitteen avulla.

Avertissement Ne pas fixer le faisceau des yeux, ni l'observer directement à l'aide d'instruments optiques.

Warnung Nicht direkt in den Strahl blicken und ihn nicht direkt mit optischen Geräten prüfen.

Avvertenza Non fissare il raggio con gli occhi né usare strumenti ottici per osservarlo direttamente.

Advarsel Stirr eller se ikke direkte p strlen med optiske instrumenter.

Aviso Não olhe fixamente para o raio, nem olhe para ele directamente com instrumentos ópticos.

¡Atención! No mirar fijamente el haz ni observarlo directamente con instrumentos ópticos.

Warning! Rikta inte blicken in mot strålen och titta inte direkt på den genom optiska instrument.

Radiation from Open Port Apertures Warning



LASER WARNING: Because invisible radiation might be emitted from the aperture of the port when no fiber cable is connected, avoid exposure to radiation and do not stare into open apertures.

Waarschuwing Aangezien onzichtbare straling vanuit de opening van de poort kan komen als er geen fiberkabel aangesloten is, dient blootstelling aan straling en het kijken in open openingen vermeden te worden.

Varoitus Koska portin aukosta voi emittoitua näkymätöntä säteilyä, kun kuitukaapelia ei ole kytkettyä, vältä säteilylle altistumista äläkä katso avoimiin aukkoihin.

Avertissement Des radiations invisibles à l'il nu pouvant traverser l'ouverture du port lorsqu'aucun câble en fibre optique n'y est connecté, il est recommandé de ne pas regarder fixement l'intérieur de ces ouvertures.

Warnung Aus der Port-Öffnung können unsichtbare Strahlen emittieren, wenn kein Glasfaserkabel angeschlossen ist. Vermeiden Sie es, sich den Strahlungen auszusetzen, und starren Sie nicht in die Öffnungen!

Avvertenza Quando i cavi in fibra non sono inseriti, radiazioni invisibili possono essere emesse attraverso l'apertura della porta. Evitate di esporvi alle radiazioni e non guardate direttamente nelle aperture.

Advarsel Unngå utsettelse for stråling, og stirr ikke inn i åpninger som er åpne, fordi usynlig stråling kan emitteres fra portens åpning når det ikke er tilkoblet en fiberkabel.

Aviso Dada a possibilidade de emissão de radiação invisível através do orifício da via de acesso, quando esta não tiver nenhum cabo de fibra conectado, deverá evitar a EXposição à radiação e não deverá olhar fixamente para orifícios que se encontrarem a descoberto.

¡Atención! Debido a que la apertura del puerto puede emitir radiación invisible cuando no existe un cable de fibra conectado, evite mirar directamente a las aperturas para no exponerse a la radiación.

Warning! Osynlig strålning kan avges från en portöppning utan ansluten fiberkabel och du bör därför undvika att bli utsatt för strålning genom att inte stirra in i oskyddade öppningar.

Maintenance and Operational Safety Guidelines and Warnings

IN THIS SECTION

- Battery Handling Warning | 91
- Jewelry Removal Warning | 92
- Lightning Activity Warning | 94
- Operating Temperature Warning | 95
- Product Disposal Warning | 96

While performing the maintenance activities for devices, observe the following guidelines and warnings:

Battery Handling Warning



WARNING: Replacing a battery incorrectly might result in an explosion. Replace a battery only with the same or equivalent type recommended by the manufacturer. Dispose of used batteries according to the manufacturer's instructions.

Waarschuwing Er is ontploffingsgevaar als de batterij verkeerd vervangen wordt. Vervang de batterij slechts met hetzelfde of een equivalent type dat door de fabrikant aanbevolen is. Gebruikte batterijen dienen overeenkomstig fabrieksvoorschriften weggeworpen te worden.

Varoitus Räjähdyksen vaara, jos akku on vaihdettu väärään akkuun. Käytä vaihtamiseen ainoastaan saman- tai vastaaventyypistä akkua, joka on valmistajan suosittama. Hävitä käytetyt akut valmistajan ohjeiden mukaan.

Avertissement Danger d'explosion si la pile n'est pas remplacée correctement. Ne la remplacer que par une pile de type semblable ou équivalent, recommandée par le fabricant. Jeter les piles usagées conformément aux instructions du fabricant.

Warnung Bei Einsetzen einer falschen Batterie besteht Explosionsgefahr. Ersetzen Sie die Batterie nur durch den gleichen oder vom Hersteller empfohlenen Batterietyp. Entsorgen Sie die benutzten Batterien nach den Anweisungen des Herstellers.

Advarsel Det kan være fare for eksplosjon hvis batteriet skiftes på feil måte. Skift kun med samme eller tilsvarende type som er anbefalt av produsenten. Kasser brukte batterier i henhold til produsentens instruksjoner.

Avvertenza Pericolo di esplosione se la batteria non è installata correttamente. Sostituire solo con una di tipo uguale o equivalente, consigliata dal produttore. Eliminare le batterie usate secondo le istruzioni del produttore.

Aviso Existe perigo de explosão se a bateria for substituída incorrectamente. Substitua a bateria por uma bateria igual ou de um tipo equivalente recomendado pelo fabricante. Destrua as baterias usadas conforme as instruções do fabricante.

¡Atención! Existe peligro de explosión si la batería se reemplaza de manera incorrecta. Reemplazar la batería EXclusivamente con el mismo tipo o el equivalente recomendado por el fabricante. Desechar las baterías gastadas según las instrucciones del fabricante.

Varning! Explosionsfara vid felaktigt batteribyte. Ersätt endast batteriet med samma batterityp som rekommenderas av tillverkaren eller motsvarande. Följ tillverkarens anvisningar vid kassering av använda batterier.

Jewelry Removal Warning



WARNING: Before working on equipment that is connected to power lines, remove jewelry, including rings, necklaces, and watches. Metal objects heat up when connected to power and ground and can cause serious burns or can be welded to the terminals.

Waarschuwing Alvorens aan apparatuur te werken die met elektrische leidingen is verbonden, sieraden (inclusief ringen, kettingen en horloges) verwijderen. Metalen voorwerpen worden warm wanneer ze met stroom en aarde zijn verbonden, en kunnen ernstige brandwonden veroorzaken of het metalen voorwerp aan de aansluitklemmen lassen.

Varoitus Ennen kuin työskentelet voimavirtajohtoihin kytkettyjen laitteiden parissa, ota pois kaikki korut (sormukset, kaulakorut ja kellot mukaan lukien). Metalliesineet kuumenevat, kun ne ovat yhteydessä sähkövirran ja maan kanssa, ja ne voivat aiheuttaa vakavia palovammoja tai hitsata metalliesineet kiinni liitännänapoihin.

Avertissement Avant d'accéder à cet équipement connecté aux lignes électriques, ôter tout bijou (anneaux, colliers et montres compris). Lorsqu'ils sont branchés à l'alimentation et reliés à la terre, les objets métalliques chauffent, ce qui peut provoquer des blessures graves ou souder l'objet métallique aux bornes.

Warnung Vor der Arbeit an Geräten, die an das Netz angeschlossen sind, jeglichen Schmuck (einschließlich Ringe, Ketten und Uhren) abnehmen. Metallgegenstände erhitzen sich, wenn sie an das Netz und die Erde angeschlossen werden, und können schwere Verbrennungen verursachen oder an die Anschlußklemmen angeschweißt werden.

Avvertenza Prima di intervenire su apparecchiature collegate alle linee di alimentazione, togliersi qualsiasi monile (inclusi anelli, collane, braccialetti ed orologi). Gli oggetti metallici si riscaldano quando sono collegati tra punti di alimentazione e massa: possono causare ustioni gravi oppure il metallo può saldarsi ai terminali.

Advarsel Fjern alle smykker (inkludert ringer, halskjeder og klokker) før du skal arbeide på utstyr som er koblet til kraftledninger. Metallgjenstander som er koblet til kraftledninger og jord blir svært varme og kan forårsake alvorlige brannskader eller smelte fast til polene.

Aviso Antes de trabalhar em equipamento que esteja ligado a linhas de corrente, retire todas as jóias que estiver a usar (incluindo anéis, fios e relógios). Os objectos metálicos aquecerão em contacto com a corrente e em contacto com a ligação à terra, podendo causar queimaduras graves ou ficarem soldados aos terminais.

¡Atención! Antes de operar sobre equipos conectados a líneas de alimentación, quitarse las joyas (incluidos anillos, collares y relojes). Los objetos de metal se calientan cuando se conectan a la alimentación y a tierra, lo que puede ocasionar quemaduras graves o que los objetos metálicos queden soldados a los bornes.

Warning! Tag av alla smycken (inklusive ringar, halsband och armbandsur) innan du arbetar på utrustning som är kopplad till kraftledning. Metallobjekt hettas upp när de kopplas ihop med ström och jord och kan förorsaka allvarliga brännskador; metallobjekt kan också sammansvetsas med kontakterna.

Lightning Activity Warning



WARNING: Do not work on the system or connect or disconnect cables during periods of lightning activity.

Waarschuwing Tijdens onweer dat gepaard gaat met bliksem, dient u niet aan het systeem te werken of kabels aan te sluiten of te ontkoppelen.

Varoitus Älä työskentele järjestelmän parissa äläkä yhdistä tai irrota kaapeleita ukkosilmalla.

Avertissement Ne pas travailler sur le système ni brancher ou débrancher les câbles pendant un orage.

Warnung Arbeiten Sie nicht am System und schließen Sie keine Kabel an bzw. trennen Sie keine ab, wenn es gewittert.

Avvertenza Non lavorare sul sistema o collegare oppure scollegare i cavi durante un temporale con fulmini.

Advarsel Utfør aldri arbeid på systemet, eller koble kabler til eller fra systemet når det tordner eller lyner.

Aviso Não trabalhe no sistema ou ligue e desligue cabos durante períodos de mau tempo (trovoada).

¡Atención! No operar el sistema ni conectar o desconectar cables durante el transcurso de descargas eléctricas en la atmósfera.

Warning! Vid åska skall du aldrig utföra arbete på systemet eller ansluta eller koppla loss kablar.

Operating Temperature Warning



WARNING: To prevent the device from overheating, do not operate it in an area that exceeds the maximum recommended ambient temperature. To prevent airflow restriction, allow at least 6 in. (15.2 cm) of clearance around the ventilation openings.

Waarschuwing Om te voorkomen dat welke switch van de Juniper Networks router dan ook oververhit raakt, dient u deze niet te bedienen op een plaats waar de maximale aanbevolen omgevingstemperatuur van 40° C wordt overschreden. Om te voorkomen dat de luchtstroom wordt beperkt, dient er minstens 15,2 cm speling rond de ventilatie-openingen te zijn.

Varoitus Ettei Juniper Networks switch-sarjan reititin ylikuumentuisi, sitä ei saa käyttää tilassa, jonka lämpötila ylittää korkeimman suositellun ympäristölämpötilan 40° C. Ettei ilmanvaihto estyisi, tuuletusaukkojen ympärille on jätettävä ainakin 15,2 cm tilaa.

Avertissement Pour éviter toute surchauffe des routeurs de la gamme Juniper Networks switch, ne l'utilisez pas dans une zone où la température ambiante est supérieure à 40° C. Pour permettre un flot d'air constant, dégagez un espace d'au moins 15,2 cm autour des ouvertures de ventilations.

Warnung Um einen Router der switch vor Überhitzung zu schützen, darf dieser nicht in einer Gegend betrieben werden, in der die Umgebungstemperatur das empfohlene Maximum von 40° C überschreitet. Um Lüftungsverschluß zu verhindern, achten Sie darauf, daß mindestens 15,2 cm lichter Raum um die Lüftungsöffnungen herum frei bleibt.

Avvertenza Per evitare il surriscaldamento dei switch, non adoperateli in un locale che ecceda la temperatura ambientale massima di 40° C. Per evitare che la circolazione dell'aria sia impedita, lasciate uno spazio di almeno 15.2 cm di fronte alle aperture delle ventole.

Advarsel Unngå overoppheting av eventuelle rutere i Juniper Networks switch Disse skal ikke brukes på steder der den anbefalte maksimale omgivelsestemperaturen overstiger 40° C (104° F). Sørg for at klaringen rundt lufteåpningene er minst 15,2 cm (6 tommer) for å forhindre nedsatt luftsirkulasjon.

Aviso Para evitar o sobreaquecimento do encaminhador Juniper Networks switch, não utilize este equipamento numa área que exceda a temperatura máxima recomendada de 40° C. Para evitar a restrição à circulação de ar, deixe pelo menos um espaço de 15,2 cm à volta das aberturas de ventilação.

¡Atención! Para impedir que un encaminador de la serie Juniper Networks switch se recaliente, no lo haga funcionar en un área en la que se supere la temperatura ambiente máxima recomendada de 40° C. Para impedir la restricción de la entrada de aire, deje un espacio mínimo de 15,2 cm alrededor de las aperturas para ventilación.

Warning! Förhindra att en Juniper Networks switch överhettas genom att inte använda den i ett område där den maximalt rekommenderade omgivningstemperaturen på 40° C överskrids. Förhindra att luftcirkulationen inskränks genom att se till att det finns fritt utrymme på minst 15,2 cm omkring ventilationsöppningarna.

Product Disposal Warning



WARNING: Disposal of this device must be handled according to all national laws and regulations.

Waarschuwing Dit produkt dient volgens alle landelijke wetten en voorschriften te worden afgedankt.

Varoitus Tämän tuotteen lopullisesta hävittämisestä tulee huolehtia kaikkia valtakunnallisia lakeja ja säännöksiä noudattaen.

Avertissement La mise au rebut définitive de ce produit doit être effectuée conformément à toutes les lois et réglementations en vigueur.

Warnung Dieses Produkt muß den geltenden Gesetzen und Vorschriften entsprechend entsorgt werden.

Avvertenza L'eliminazione finale di questo prodotto deve essere eseguita osservando le normative italiane vigenti in materia

Advarsel Endelig disponering av dette produktet må skje i henhold til nasjonale lover og forskrifter.

Aviso A descartagem final deste produto deverá ser efectuada de acordo com os regulamentos e a legislação nacional.

¡Atención! El desecho final de este producto debe realizarse según todas las leyes y regulaciones nacionales

Warning! Slutlig kassering av denna produkt bör skötas i enlighet med landets alla lagar och föreskrifter.

General Electrical Safety Guidelines and Warnings

IN THIS SECTION

- Safety Guidelines and Warnings | 97
- Grounded Equipment Warning | 98
- Backplane Energy Hazard Warning | 99
- Multiple Power Supplies Disconnection Warning | 99
- Power Disconnection Warning | 100
- TN Power Warning | 101
- Copper Conductors Warning | 101

Safety Guidelines and Warnings

- Install the services gateway in compliance with the following local, national, or international electrical codes:
 - United States—National Fire Protection Association (NFPA 70), United States National Electrical Code
 - Canada—Canadian Electrical Code, Part 1, CSA C22.1
 - Other countries—International Electromechanical Commission (IEC) 60364, Part 1 through Part 7
 - Evaluated to the TN power system
- Locate the emergency power-off switch for the room in which you are working so that if an electrical accident occurs, you can quickly turn off the power.
- Do not work alone if potentially hazardous conditions exist anywhere in your workspace.
- Never assume that power is disconnected from a circuit. Always check the circuit before starting to work.
- Carefully look for possible hazards in your work area, such as moist floors, ungrounded power extension cords, and missing safety grounds.

- Operate the services gateway within marked electrical ratings and product usage instructions.
- For the services gateway and peripheral equipment to function safely and correctly, use the cables and connectors specified for the attached peripheral equipment, and make certain they are in good condition.

The SRX4100 and SRX4200 devices are suitable for installation in Information Technology Rooms in accordance with Article 645 of the National Electrical Code and NFPA 75.

Peut être installé dans des salles de matériel de traitement de l'information conformément à l'article 645 du National Electrical Code et à la NFPA 75.

Grounded Equipment Warning



WARNING: The services gateway is intended to be grounded. Ensure that the services gateway is connected to earth ground during normal use.

Waarschuwing Deze apparatuur hoort geaard te worden. Zorg dat de host-computer tijdens normaal gebruik met aarde is verbonden.

Varoitus Tämä laitteisto on tarkoitettu maadoitettavaksi. Varmista, että isäntälaitte on yhdistetty maahan normaalikäytön aikana.

Attention Cet équipement doit être relié à la terre. S'assurer que l'appareil hôte est relié à la terre lors de l'utilisation normale.

Warnung Dieses Gerät muß geerdet werden. Stellen Sie sicher, daß das Host-Gerät während des normalen Betriebs an Erde gelegt ist.

Avvertenza Questa apparecchiatura deve essere collegata a massa. Accertarsi che il dispositivo host sia collegato alla massa di terra durante il normale utilizzo.

Advarsel Dette utstyret skal jordes. Forviss deg om vertsterminalen er jordet ved normalt bruk.

Aviso Este equipamento deverá estar ligado à terra. Certifique-se que o host se encontra ligado à terra durante a sua utilização normal.

¡Atención! Este equipo debe conectarse a tierra. Asegurarse de que el equipo principal esté conectado a tierra durante el uso normal.

Warning! Denna utrustning är avsedd att jordas. Se till att värdenheten är jordad vid normal användning.

Backplane Energy Hazard Warning



WARNING: High levels of electrical energy are distributed across the services gateway backplane. Be careful not to contact the backplane connectors, or any component connected to the backplane, with any metallic object while servicing components installed in the services gateway.

Multiple Power Supplies Disconnection Warning



WARNING: The services gateway has more than one power supply connection. All connections must be removed completely to remove power from the unit completely.

Waarschuwing Deze eenheid heeft meer dan één stroomtoevoerverbinding; alle verbindingen moeten volledig worden verwijderd om de stroom van deze eenheid volledig te verwijderen.

Varoitus Tässä laitteessa on useampia virtalähdekytkentöjä. Kaikki kytkennät on irrotettava kokonaan, jotta virta poistettaisiin täysin laitteesta.

Attention Cette unité est équipée de plusieurs raccordements d'alimentation. Pour supprimer tout courant électrique de l'unité, tous les cordons d'alimentation doivent être débranchés.

Warnung Diese Einheit verfügt über mehr als einen Stromanschluß; um Strom gänzlich von der Einheit fernzuhalten, müssen alle Stromzufuhren abgetrennt sein.

Avvertenza Questa unità ha più di una connessione per alimentatore elettrico; tutte le connessioni devono essere completamente rimosse per togliere l'elettricità dall'unità.

Advarsel Denne enheten har mer enn én strømtilkobling. Alle tilkoblinger må kobles helt fra for å eliminere strøm fra enheten.

Aviso Este dispositivo possui mais do que uma conexão de fonte de alimentação de energia; para poder remover a fonte de alimentação de energia, deverão ser desconectadas todas as conexões existentes.

¡Atención! Esta unidad tiene más de una conexión de suministros de alimentación; para eliminar la alimentación por completo, deben desconectarse completamente todas las conexiones.

Warning! Denna enhet har mer än en strömförsörjningsanslutning; alla anslutningar måste vara helt avlägsnade innan strömtillförseln till enheten är fullständigt bruten.

Power Disconnection Warning



WARNING: Before working on the services gateway or near power supplies, unplug the power cord from an AC-powered services gateway; switch off the power at the circuit breaker on a DC-powered services gateway.

Waarschuwing Voordat u aan een frame of in de nabijheid van voedingen werkt, dient u bij wisselstroom toestellen de stekker van het netsnoer uit het stopcontact te halen; voor gelijkstroom toestellen dient u de stroom uit te schakelen bij de stroomverbreker.

Varoitus Kytke irti vaihtovirtalaitteiden virtajohto ja katkaise tasavirtalaitteiden virta suojakytkimellä, ennen kuin teet mitään asennuspohjalle tai työskentelet virtalähteiden läheisyydessä.

Attention Avant de travailler sur un châssis ou à proximité d'une alimentation électrique, débrancher le cordon d'alimentation des unités en courant alternatif; couper l'alimentation des unités en courant continu au niveau du disjoncteur.

Warnung Bevor Sie an einem Chassis oder in der Nähe von Netzgeräten arbeiten, ziehen Sie bei Wechselstromeinheiten das Netzkabel ab bzw. schalten Sie bei Gleichstromeinheiten den Strom am Unterbrecher ab.

Avvertenza Prima di lavorare su un telaio o intorno ad alimentatori, scollegare il cavo di alimentazione sulle unità CA; scollegare l'alimentazione all'interruttore automatico sulle unità CC.

Advarsel Før det utføres arbeid på kabinettet eller det arbeides i nærheten av strømforsyningsenheter, skal strømleningen trekkes ut p vekselstrømsenheter og strømmen kobles fra ved strømbryteren på likestrømsenheter.

Aviso Antes de trabalhar num chassis, ou antes de trabalhar perto de unidades de fornecimento de energia, desligue o cabo de alimentação nas unidades de corrente alternada; desligue a corrente no disjuntor nas unidades de corrente contínua.

¡Atención! Antes de manipular el chasis de un equipo o trabajar cerca de una fuente de alimentación, desenchufar el cable de alimentación en los equipos de corriente alterna

(CA); cortar la alimentación desde el interruptor automático en los equipos de corriente continua (CC).

Warning! Innan du arbetar med ett chassi eller nära strömförsörjningsenheter skall du för växelströmsenheter dra ur nätsladden och för likströmsenheter bryta strömmen vid överspänningsskyddet.

TN Power Warning



WARNING: The services gateway is designed to work with TN power systems.

Waarschuwing Het apparaat is ontworpen om te functioneren met TN energiesystemen.

Varoitus Koje on suunniteltu toimimaan TN-sähkövoimajärjestelmien yhteydessä.

Attention Ce dispositif a été conçu pour fonctionner avec des systèmes d'alimentation TN.

Warnung Das Gerät ist für die Verwendung mit TN-Stromsystemen ausgelegt.

Avvertenza Il dispositivo è stato progettato per l'uso con sistemi di alimentazione TN.

Advarsel Utstyret er utfomet til bruk med TN-strømsystemer.

Aviso O dispositivo foi criado para operar com sistemas de corrente TN.

¡Atención! El equipo está diseñado para trabajar con sistemas de alimentación tipo TN.

Warning! Enheten är konstruerad för användning tillsammans med elkraftssystem av TN-typ.

Copper Conductors Warning



WARNING: Use copper conductors only.

Waarschuwing Gebruik alleen koperen geleiders.

Varoitus Käytä vain kuparijohtimia.

Attention Utilisez uniquement des conducteurs en cuivre.

Warnung Verwenden Sie ausschließlich Kupferleiter.

Avvertenza Usate unicamente dei conduttori di rame.

Advarsel Bruk bare kobberledninger.

Aviso Utilize apenas fios condutores de cobre.

¡Atención! Emplee sólo conductores de cobre.

Varning! Använd endast ledare av koppar.

RELATED DOCUMENTATION

[AC Power Electrical Safety Guidelines](#)

[DC Power Electrical Safety Guidelines | 103](#)

[In Case of an Electrical Accident](#)

AC Power Electrical Safety Guidelines

The following electrical safety guidelines apply to AC-powered devices:

- Note the following warnings printed on the device:

“CAUTION: THIS UNIT HAS MORE THAN ONE POWER SUPPLY CORD. DISCONNECT ALL POWER SUPPLY CORDS BEFORE SERVICING TO AVOID ELECTRIC SHOCK.”

“ATTENTION: CET APPAREIL COMPORTE PLUS D'UN CORDON D'ALIMENTATION. AFIN DE PRÉVENIR LES CHOCS ÉLECTRIQUES, DÉBRANCHER TOUT CORDON D'ALIMENTATION AVANT DE FAIRE LE DÉPANNAGE.”

- AC-powered devices are shipped with a three-wire electrical cord with a grounding-type plug that fits only a grounding-type power outlet. Do not circumvent this safety feature. Equipment grounding must comply with local and national electrical codes.
- You must provide an external certified circuit breaker (2-pole circuit breaker or 4-pole circuit breaker based on your device) rated minimum 20 A in the building installation.
- The power cord serves as the main disconnecting device for the AC-powered device. The socket outlet must be near the AC-powered device and be easily accessible.

- For devices that have more than one power supply connection, you must ensure that all power connections are fully disconnected so that power to the device is completely removed to prevent electric shock. To disconnect power, unplug all power cords (one for each power supply).

Power Cable Warning (Japanese)

WARNING: The attached power cable is only for this product. Do not use the cable for another product.

注意

附属の電源コードセットはこの製品専用です。
他の電気機器には使用しないでください。

0417283

DC Power Electrical Safety Guidelines

The following electrical safety guidelines apply to a DC-powered services gateway:

- A DC-powered services gateway is equipped with a DC terminal block that is rated for the power requirements of a maximally configured services gateway. To supply sufficient power, terminate the DC input wiring on a facility DC source capable of supplying at least 30 A @ -48 VDC for the system. We recommend that the 48 VDC facility DC source be equipped with a circuit breaker rated at 9 A (-48 VDC) minimum, or as required by local code. Incorporate an easily accessible disconnect device into the facility wiring. In the United States and Canada, the -48 VDC facility should be equipped with a circuit breaker rated a minimum of 125% of the power provisioned for the input in accordance with the National Electrical Code in the US and the Canadian Electrical Code in Canada. Be sure to connect the ground wire or conduit to a solid office (earth) ground. A closed loop ring is recommended for terminating the ground conductor at the ground stud.
- Run two wires from the circuit breaker box to a source of 48 VDC. Use appropriate gauge wire to handle up to 40 A.
- A DC-powered services gateway that is equipped with a DC terminal block is intended only for installation in a restricted access location. In the United States, a restricted access area is one in accordance with Articles 110-16, 110-17, and 110-18 of the National Electrical Code ANSI/NFPA 70.

NOTE: Primary overcurrent protection is provided by the building circuit breaker. This breaker should protect against excess currents, short circuits, and earth faults in accordance with NEC ANSI/NFPA70.

- Ensure that the polarity of the DC input wiring is correct. Under certain conditions, connections with reversed polarity might trip the primary circuit breaker or damage the equipment.
- For personal safety, connect the green and yellow wire to safety (earth) ground at both the services gateway and the supply side of the DC wiring.
- The marked input voltage of -48 VDC for a DC-powered services gateway is the nominal voltage associated with the battery circuit, and any higher voltages are only to be associated with float voltages for the charging function.
- Because the services gateway is a positive ground system, you must connect the positive lead to the terminal labeled **RETURN**, the negative lead to the terminal labeled **-48V**, and the earth ground to the chassis grounding points.

RELATED DOCUMENTATION

| [General Electrical Safety Guidelines and Warnings | 97](#)

DC Power Disconnection Warning



WARNING: Before performing any of the DC power procedures, ensure that power is removed from the DC circuit. To ensure that all power is off, locate the circuit breaker on the panel board that services the DC circuit, switch the circuit breaker to the OFF position, and tape the device handle of the circuit breaker in the OFF position.

Waarschuwing Voordat u een van de onderstaande procedures uitvoert, dient u te controleren of de stroom naar het gelijkstroom circuit uitgeschakeld is. Om u ervan te verzekeren dat alle stroom UIT is geschakeld, kiest u op het schakelbord de stroomverbreker die het gelijkstroom circuit bedient, draait de stroomverbreker naar de UIT positie en plakt de schakelaarhendel van de stroomverbreker met plakband in de UIT positie vast.

Varoitus Varmista, että tasavirtapiirissä ei ole virtaa ennen seuraavien toimenpiteiden suorittamista. Varmistaaksesi, että virta on KATKAISTU täysin, paikanna tasavirrasta huolehtivassa kojetaulussa sijaitseva suojakytkin, käännä suojakytkin KATKAISTU-asentoon ja teippaa suojakytkimen varsi niin, että se pysyy KATKAISTU-asennossa.

Avertissement Avant de pratiquer l'une quelconque des procédures ci-dessous, vérifier que le circuit en courant continu n'est plus sous tension. Pour en être sûr, localiser le disjoncteur situé sur le panneau de service du circuit en courant continu, placer le disjoncteur en position fermée (OFF) et, à l'aide d'un ruban adhésif, bloquer la poignée du disjoncteur en position OFF.

Warnung Vor Ausführung der folgenden Vorgänge ist sicherzustellen, daß die Gleichstromschaltung keinen Strom erhält. Um sicherzustellen, daß sämtlicher Strom abgestellt ist, machen Sie auf der Schalttafel den Unterbrecher für die Gleichstromschaltung ausfindig, stellen Sie den Unterbrecher auf AUS, und kleben Sie den Schaltergriff des Unterbrechers mit Klebeband in der AUS-Stellung fest.

Avvertenza Prima di svolgere una qualsiasi delle procedure seguenti, verificare che il circuito CC non sia alimentato. Per verificare che tutta l'alimentazione sia scollegata (OFF), individuare l'interruttore automatico sul quadro strumenti che alimenta il circuito CC, mettere l'interruttore in posizione OFF e fissarlo con nastro adesivo in tale posizione.

Advarsel Før noen av disse prosedyrene utføres, kontroller at strømmen er frakoblet likestrømkretsen. Sørg for at all strøm er slått AV. Dette gjøres ved å lokalisere strømbryteren på brytertavlen som betjener likestrømkretsen, slå strømbryteren AV og teipe bryterhåndtaket på strømbryteren i AV-stilling.

Aviso Antes de executar um dos seguintes procedimentos, certifique-se que desligou a fonte de alimentação de energia do circuito de corrente contínua. Para se assegurar que toda a corrente foi DESLIGADA, localize o disjuntor no painel que serve o circuito de corrente contínua e coloque-o na posição OFF (Desligado), segurando nessa posição a manivela do interruptor do disjuntor com fita isoladora.

¡Atención! Antes de proceder con los siguientes pasos, comprobar que la alimentación del circuito de corriente continua (CC) esté cortada (OFF). Para asegurarse de que toda la alimentación esté cortada (OFF), localizar el interruptor automático en el panel que alimenta al circuito de corriente continua, cambiar el interruptor automático a la posición de Apagado (OFF), y sujetar con cinta la palanca del interruptor automático en posición de Apagado (OFF).

Varning! Innan du utför någon av följande procedurer måste du kontrollera att strömförsörjningen till likstrømkretsen är bruten. Kontrollera att all strömförsörjning är

BRUTEN genom att slå AV det överspänningsskydd som skyddar likströmskretsen och tejpa fast överspänningsskyddets omkopplare i FRÅN-läget.

DC Power Grounding Requirements and Warning

An insulated grounding conductor that is identical in size to the grounded and ungrounded branch circuit supply conductors but is identifiable by green and yellow stripes is installed as part of the branch circuit that supplies the device. The grounding conductor is a separately derived system at the supply transformer or motor generator set.



WARNING: When you install the device, the ground connection must always be made first and disconnected last.

Waarschuwing Bij de installatie van het toestel moet de aardverbinding altijd het eerste worden gemaakt en het laatste worden losgemaakt.

Varoitus Laitetta asennettaessa on maahan yhdistäminen aina tehtävä ensiksi ja maadoituksen irti kytkeminen viimeiseksi.

Avertissement Lors de l'installation de l'appareil, la mise à la terre doit toujours être connectée en premier et déconnectée en dernier.

Warnung Der Erdanschluß muß bei der Installation der Einheit immer zuerst hergestellt und zuletzt abgetrennt werden.

Avvertenza In fase di installazione dell'unità, eseguire sempre per primo il collegamento a massa e disconnetterlo per ultimo.

Advarsel Når enheten installeres, må jordledningen alltid tilkobles først og frakobles sist.

Aviso Ao instalar a unidade, a ligação à terra deverá ser sempre a primeira a ser ligada, e a última a ser desligada.

¡Atención! Al instalar el equipo, conectar la tierra la primera y desconectarla la última.

Warning! Vid installation av enheten måste jordledningen alltid anslutas först och kopplas bort sist.

DC Power Wiring Sequence Warning



WARNING: Wire the DC power supply using the appropriate lugs. When connecting power, the proper wiring sequence is ground to ground, +RTN to +RTN, then -48 V to -48 V. When disconnecting power, the proper wiring sequence is -48 V to -48 V, +RTN to +RTN, then ground to ground. Note that the ground wire must always be connected first and disconnected last.

Waarschuwing De juiste bedradingsvolgorde verbonden is aarde naar aarde, +RTN naar +RTN, en -48 V naar -48 V. De juiste bedradingsvolgorde losgemaakt is en -48 naar -48 V, +RTN naar +RTN, aarde naar aarde.

Varoitus Oikea yhdistettava kytkentajarjestys on maajohto maajohtoon, +RTN varten +RTN, -48 V varten -48 V. Oikea irrotettava kytkentajarjestys on -48 V varten -48 V, +RTN varten +RTN, maajohto maajohtoon.

Avertissement Câblez l'alimentation d'alimentation CC En utilisant les crochets appropriés à l'extrémité de câblage. En reliant la puissance, l'ordre approprié de câblage est rectifié pour rectifier, +RTN à +RTN, puis -48 V à -48 V. En débranchant la puissance, l'ordre approprié de câblage est -48 V à -48 V, +RTN à +RTN, a alors rectifié pour rectifier. Notez que le fil de masse devrait toujours être relié d'abord et débranché pour la dernière fois. Notez que le fil de masse devrait toujours être relié d'abord et débranché pour la dernière fois.

Warnung Die Stromzufuhr ist nur mit geeigneten Ringösen an das DC Netzteil anzuschliessen. Die richtige Anschlusssequenz ist: Erdanschluss zu Erdanschluss, +RTN zu +RTN und dann -48V zu -48V. Die richtige Sequenz zum Abtrennen der Stromversorgung ist -48V zu -48V, +RTN zu +RTN und dann Erdanschluss zu Erdanschluss. Es ist zu beachten dass der Erdanschluss immer zuerst angeschlossen und als letztes abgetrennt wird.

Avvertenza Mostra la morsettiera dell'alimentatore CC. Cablare l'alimentatore CC usando i connettori adatti all'estremità del cablaggio, come illustrato. La corretta sequenza di cablaggio è da massa a massa, da positivo a positivo (da linea ad L) e da negativo a negativo (da neutro a N). Tenere presente che il filo di massa deve sempre venire collegato per primo e scollegato per ultimo.

Advarsel Riktig tilkoples tilkoplingssekvens er jord til jord, +RTN til +RTN, -48 V til -48 V. Riktig frakoples tilkoplingssekvens er -48 V til -48 V, +RTN til +RTN, jord til jord.

Aviso Ate con alambre la fuente de potencia cc Usando los terminales apropiados en el extremo del cableado. Al conectar potencia, la secuencia apropiada del cableado se

muele para moler, +RTN a +RTN, entonces -48 V a -48 V. Al desconectar potencia, la secuencia apropiada del cableado es -48 V a -48 V, +RTN a +RTN, entonces molió para moler. Observe que el alambre de tierra se debe conectar siempre primero y desconectar por último. Observe que el alambre de tierra se debe conectar siempre primero y desconectar por último.

¡Atención! Wire a fonte de alimentação de DC Usando os talões apropriados nan EXTremidade da fiação. Ao conectar a potência, a seqüência apropriada da fiação é moída para moer, +RTN a +RTN, então -48 V a -48 V. Ao desconectar a potência, a seqüência apropriada da fiação é -48 V a -48 V, +RTN a +RTN, moeu então para moer. Anote que o fio à terra deve sempre ser conectado primeiramente e desconectado por último. Anote que o fio à terra deve sempre ser conectado primeiramente e desconectado por último.

Warning! Korrekt kopplingssekvens ar jord till jord, +RTN till +RTN, -48 V till -48 V. Korrekt kopplas kopplingssekvens ar -48 V till -48 V, +RTN till +RTN, jord till jord.

DC Power Wiring Terminations Warning



WARNING: When stranded wiring is required, use approved wiring terminations, such as closed-loop or spade-type with upturned lugs. These terminations must be the appropriate size for the wires and must clamp both the insulation and conductor.

Waarschuwing Wanneer geslagen bedrading vereist is, dient u bedrading te gebruiken die voorzien is van goedgekeurde aansluitpunten, zoals het gesloten-lus type of het grijperschop type waarbij de aansluitpunten omhoog wijzen. Deze aansluitpunten dienen de juiste maat voor de draden te hebben en dienen zowel de isolatie als de geleider vast te klemmen.

Varoitus Jos säikeellinen johdin on tarpeen, käytä hyväksyttyä johdinliitääntä, esimerkiksi suljettua silmukkaa tai kourumaista liitääntä, jossa on ylöspäin käännetyt kiinnityskorvat. Tällaisten liitääntöjen tulee olla kooltaan johtimiin sopivia ja niiden tulee puristaa yhteen sekä eristeen että johdinosan.

Avertissement Quand des fils torsadés sont nécessaires, utiliser des douilles terminales homologuées telles que celles à circuit fermé ou du type à plage ouverte avec cosses rebroussées. Ces douilles terminales doivent être de la taille qui convient aux fils et doivent être refermées sur la gaine isolante et sur le conducteur.

Warnung Wenn Litzenverdrahtung erforderlich ist, sind zugelassene Verdrahtungsabschlüsse, z.B. für einen geschlossenen Regelkreis oder gabelförmig, mit nach oben gerichteten Kabelschuhen zu verwenden. Diese Abschlüsse sollten die angemessene Größe für die Drähte haben und sowohl die Isolierung als auch den Leiter festklemmen.

Avvertenza Quando occorre usare trecce, usare connettori omologati, come quelli a occhio o a forcella con linguette rivolte verso l'alto. I connettori devono avere la misura adatta per il cablaggio e devono serrare sia l'isolante che il conduttore.

Advarsel Hvis det er nødvendig med flertrådede ledninger, brukes godkjente ledningsavslutninger, som for eksempel lukket sløyfe eller spadetype med oppoverbøyde kabelsko. Disse avslutningene skal ha riktig størrelse i forhold til ledningene, og skal klemme sammen både isolasjonen og ledaren.

Aviso Quando forem requeridas montagens de instalação eléctrica de cabo torcido, use terminações de cabo aprovadas, tais como, terminações de cabo em circuito fechado e planas com terminais de orelha voltados para cima. Estas terminações de cabo deverão ser do tamanho apropriado para os respectivos cabos, e deverão prender simultaneamente o isolamento e o fio condutor.

¡Atención! Cuando se necesite hilo trenzado, utilizar terminales para cables homologados, tales como las de tipo "bucle cerrado" o "espada", con las lengüetas de conexión vueltas hacia arriba. Estos terminales deberán ser del tamaño apropiado para los cables que se utilicen, y tendrán que sujetar tanto el aislante como el conductor.

Varning! När flertrådiga ledningar krävs måste godkända ledningskontakter användas, t.ex. kabelsko av sluten eller öppen typ med uppåtvänd tapp. Storleken på dessa kontakter måste vara avpassad till ledningarna och måste kunna hålla både isoleringen och ledaren fastklämda.

Action to Take After an Electrical Accident

If an electrical accident results in an injury, take the following actions in this order:

1. Use caution. Be aware of potentially hazardous conditions that could cause further injury.
2. Disconnect power from the device.
3. If possible, send another person to get medical aid. Otherwise, assess the condition of the victim, and then call for help.

Agency Approvals

IN THIS SECTION

- [Compliance Statement for Argentina | 111](#)

The services gateway complies with the following standards:

- Safety
 - CAN/CSA C22.2 No. 60950-1-07, 2nd Edition, 2014-10
 - EN 60950-1:2006 + A11:2009 + A1:2010 + A12:2011 + A2:2013
 - EN 60825-1 Safety of Laser Products - Part 1: Equipment Classification, Requirements and User's Guide
 - EN 60825-2 Safety of Laser Products - Part 2: Safety of Optical Fiber Communication Systems
 - UL 60950-1, 2nd Edition, 2014-10-14
 - CAN/CSA C22.2 No. 62368-1-14
 - EN 62368-1: 2014+A11: 2017
 - UL 62368-1: 2014
 - IEC 62368-1:2014 (Second Edition)
 - IEC 60950-1:2005 (Second Edition); Am1:2009 + Am2:2013
 - CE
- EMC
 - FCC Part 15 Class A (2007) USA Radiated Emissions
 - EN 55022 Class A (2006) European Radiated Emissions
 - VCCI Class A (2007) Japanese Radiated Emissions
 - FCC 47CFR , Part 15 Class A (2009) USA Radiated Emissions
 - BSMI Class A (Taiwan)

- EN 300 386 V1.3.3 (2005) Telecom Network Equipment— EMC requirements
- ICES-003 Class A
- AS/NZS CISPR 22 Class A
- CISPR 22 Class A
- Immunity
 - EN-61000-3-2 Power Line Harmonics
 - EN-61000-3-3 Voltage Fluctuations and Flicker
 - EN-61000-4-2 ESD
 - EN-61000-4-3 Radiated Immunity
 - EN-61000-4-4 EFT
 - EN-61000-4-5 Surge
 - EN-61000-4-6 Conducted Immunity
 - EN-61000-4-11 Voltage Dips and Sags
 - EN 55024 +A1+A2 (1998) Information Technology
 - 1KV / 2KV surge required (no 4KV / DT)
- ROHS
 - Reduction of Hazardous Substances (ROHS) 6
- Telco
 - Common Language Equipment Identifier (CLEI) code
- NEBS
 - Not compliant

Compliance Statement for Argentina

EQUIPO DE USO IDÓNEO.

RELATED DOCUMENTATION

Acoustic Noise Compliance Statements

EMC Requirements

Acoustic Noise Compliance Statements

The maximum emitted sound pressure level is 70 dB(A) or less per EN ISO 7779.

German Translation:

Maschinenlärminformations-Verordnung - 3. GPSGV, der höchste Schalldruckpegel beträgt 70 dB(A) oder weniger gemäss EN ISO 7779.

RELATED DOCUMENTATION

EMC Requirements

EMC Requirements

IN THIS SECTION

- [Canada | 113](#)
- [European Community | 113](#)
- [Israel | 113](#)
- [Japan | 113](#)
- [United States | 114](#)

Canada

This Class A digital apparatus complies with Canadian ICES-003.

Cet appareil numérique de la classe A est conforme à la norme NMB-003 du Canada.

European Community

This is a Class A product. In a domestic environment this product may cause radio interference in which case the user may be required to take adequate measures.

Israel

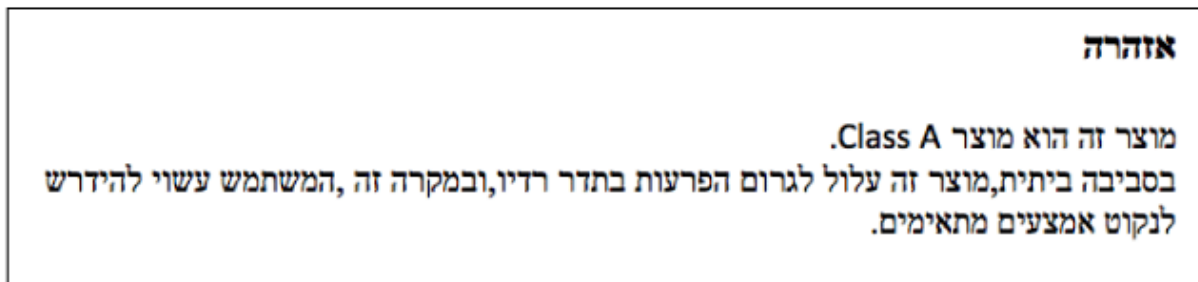

The preceding translates as follows:

This product is Class A. In residential environments, the product may cause radio interference, and in such a situation, the user may be required to take adequate measures.

Japan

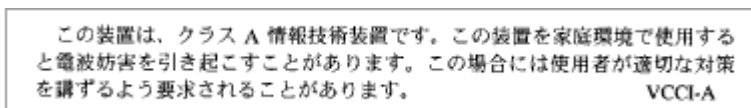

The preceding translates as follows:

This is a Class A product. In a domestic environment this product may cause radio interference in which case the user may be required to take adequate measures.

VCCI-A

United States

The firewall has been tested and found to comply with the limits for a Class A digital device of the FCC Rules. These limits are designed to provide reasonable protection against harmful interference when the equipment is operated in a commercial environment. This equipment generates, uses, and can radiate radio frequency energy and, if not installed and used in accordance with the instruction manual, may cause harmful interference to radio communications. Operation of this equipment in a residential area is likely to cause harmful interference in which case the user will be required to correct the interference at his own expense.

RELATED DOCUMENTATION

| *Acoustic Noise Compliance Statements*