

# Using CTP Bundles to Create Logical Configurations for Physical Interfaces

Published  
2023-09-01

Juniper Networks, Inc.  
1133 Innovation Way  
Sunnyvale, California 94089  
USA  
408-745-2000  
www.juniper.net

Juniper Networks, the Juniper Networks logo, Juniper, and Junos are registered trademarks of Juniper Networks, Inc. in the United States and other countries. All other trademarks, service marks, registered marks, or registered service marks are the property of their respective owners.

Juniper Networks assumes no responsibility for any inaccuracies in this document. Juniper Networks reserves the right to change, modify, transfer, or otherwise revise this publication without notice.

*Using CTP Bundles to Create Logical Configurations for Physical Interfaces*  
Copyright © 2023 Juniper Networks, Inc. All rights reserved.

The information in this document is current as of the date on the title page.

## YEAR 2000 NOTICE

Juniper Networks hardware and software products are Year 2000 compliant. Junos OS has no known time-related limitations through the year 2038. However, the NTP application is known to have some difficulty in the year 2036.

## END USER LICENSE AGREEMENT

The Juniper Networks product that is the subject of this technical documentation consists of (or is intended for use with) Juniper Networks software. Use of such software is subject to the terms and conditions of the End User License Agreement ("EULA") posted at <https://support.juniper.net/support/eula/>. By downloading, installing or using such software, you agree to the terms and conditions of that EULA.

# Table of Contents

[About This Guide | viii](#)

1

## Overview

[Using Bundles to Create Logical Configurations for Physical Interfaces Overview | 2](#)

[Types of Bundles Overview | 2](#)

[Interface Naming Conventions for the CTP Series | 5](#)

[CTP Bundle Overview | 7](#)

[Adaptive Clocking Overview for CTP Bundles | 7](#)

[Determining Optimal Packet Size for CTP Bundles Overview | 8](#)

[Providing QoS for CTP Bundles by Using Service Type Overview | 11](#)

[Circuit Startup Process Overview | 13](#)

[Network Node Reference Overview | 14](#)

[Support for Multiple Primary Nodes to Associate With a Single Member Node in NetRef | 15](#)

[Loss of Signal Detection Capability on CTP Bundles and SAToP Bundles | 17](#)

[Guidelines for Configuring LOS Detection | 20](#)

[Transparent Encoding Overview | 22](#)

[Transparent Encoding Applications and Support Overview | 22](#)

[How Basic Transparent Encoding Works | 23](#)

[Using Phase-Correction FIFO Buffer with Transparent Encoding | 24](#)

[Using Send Timing \(ST\) Clocking for Higher Speed Circuits with Transparent Encoding | 27](#)

[TDM/TDC Encoding Overview | 30](#)

[TDM/TDC Encoding Overview | 30](#)

[Ethernet Media Configuration Overview | 37](#)

[Ethernet Media Configuration Overview | 37](#)

2

## Configuration

**Configuring CTP Bundles (CTP Menu) | 40**

Adding a Bundle (CTP Menu) | 41

Configuring IP Parameters for CTP Bundles (CTP Menu) | 41

Configuring Circuit Startup Parameters for CTP Bundles (CTP Menu) | 44

Configuring the Direction of the Circuit (CTP Menu) | 46

Configuring Virtual IP Parameters for CTP Bundles (CTP Menu) | 46

Configuring the Missing Packet Fill Pattern for CTP Bundles (CTP Menu) | 47

Configuring Signaling for CTP Bundles (CTP Menu) | 48

Configuring Multiservice Port Parameters for CTP Bundles (CTPView) | 55

Configuring Multiservice Audio Mode Port Parameters for CTP Bundles (CTPView) | 55

Configuring Multiservice IRIG-B Mode Port Parameters for CTP Bundles (CTPView) | 58

Configuring Multiservice TDC Mode Parameters for CTP Bundles (CTPView) | 60

Configuring Multiservice 4WTO Mode Port Parameters for CTP Bundles (CTPView) | 62

Configuring Serial Port Parameters for CTP Bundles (CTP Menu) | 65

Configuring Transparent Encoding for CTP Bundles (CTP Menu) | 69

Configuring Bundle Pairs for TDM/TDC Operation (CTP Menu) | 72

Configuring the High-Speed CTP Bundle for TDM/TDC Operation (CTP Menu) | 73

Configuring the Low-Speed CTP Bundle for TDM/TDC Operation (CTP Menu) | 74

Configuring T1 and E1 Port Parameters for CTP Bundles (CTP Menu) | 75

Configuring Multiservice Port Parameters for CTP Bundles (CTP Menu) | 80

Configuring Multiservice Audio Mode Port Parameters for CTP Bundles (CTP Menu) | 80

Configuring Multiservice IRIG-B Mode Port Parameters for CTP Bundles (CTP Menu) | 83

Configuring Multiservice TDC Mode Parameters for CTP Bundles (CTP Menu) | 86

Configuring Multiservice 4WTO Mode Port Parameters for CTP Bundles (CTP Menu) | 87

Configuring 4WTO Port Parameters for CTP Bundles (CTP Menu) | 89

Configuring IRIG-B Port Parameters for CTP Bundles (CTP Menu) | 94

Configuring Advanced Port Options for CTP Bundles (CTP Menu) | 97

Selecting the Type of Clocking on Serial Ports for CTP Bundles (CTP Menu) | 99

Configuring Custom Clocking for CTP Bundles (CTP Menu)	103
Configuring Adaptive Clocking for CTP Bundles (CTP Menu)	110
Configuring Ethernet Media (CTP Menu)	113
Displaying Ethernet Media Information (CTP Menu)	115
Configuring PBS and Bridge Ports (CTP Menu)	115
Configuring Port Mirroring for CTP Bundles (CTP Menu)	119
Configuring NetRef for Adaptive Bundle Operation	124
Configuring NetRef for Primary or Backup Operation	125
Configuring NetRef Multiple Primary Nodes (CTP Menu)	126
Configuring NetRef Settings (CTPView)	132
Configuring LOS Detection on CTP and SAToP Bundles (CTP Menu)	134
Configuring Cryptographic Resynchronization (Crypto Resync)	135
Gathering Node Debugging Information (CTP Menu)	138
<b>Configuring CTP Bundles (CTPView)  </b>	<b>139</b>
Adding a Bundle (CTPView)	140
Configuring IP Parameters for CTP Bundles (CTPView)	140
Configuring Circuit Startup Parameters for CTP Bundles (CTPView)	143
Configuring the Direction of the Circuit (CTPView)	145
Configuring Virtual IP Parameters for CTP Bundles (CTPView)	146
Configuring the Missing Packet Fill Pattern for CTP Bundles (CTPView)	147
Configuring Signaling for CTP Bundles (CTPView)	148
Configuring Multiservice Port Parameters for CTP Bundles (CTP Menu)	154
Configuring Multiservice Audio Mode Port Parameters for CTP Bundles (CTP Menu)	154
Configuring Multiservice IRIG-B Mode Port Parameters for CTP Bundles (CTP Menu)	157
Configuring Multiservice TDC Mode Parameters for CTP Bundles (CTP Menu)	160
Configuring Multiservice 4WTO Mode Port Parameters for CTP Bundles (CTP Menu)	161
Configuring Serial Port Parameters for CTP Bundles (CTPView)	163

- Configuring Transparent Encoding for CTP Bundles (CTPView) | 167
- Configuring Bundle Pairs for TDM/TDC Operation (CTPView) | 171
  - Configuring the High-Speed CTP Bundle for TDM/TDC Operation (CTPView) | 171
  - Configuring the Low-Speed CTP Bundle for TDM/TDC Operation (CTPView) | 172
- Configuring T1 and E1 Port Parameters for CTP Bundles (CTPView) | 173
- Configuring Multiservice Port Parameters for CTP Bundles (CTPView) | 177
  - Configuring Multiservice Audio Mode Port Parameters for CTP Bundles (CTPView) | 177
  - Configuring Multiservice IRIG-B Mode Port Parameters for CTP Bundles (CTPView) | 180
  - Configuring Multiservice TDC Mode Parameters for CTP Bundles (CTPView) | 182
  - Configuring Multiservice 4WTO Mode Port Parameters for CTP Bundles (CTPView) | 183
- Configuring 4WTO Port Parameters for CTP Bundles (CTPView) | 186
- Configuring IRIG-B Port Parameters for CTP Bundles (CTPView) | 191
- Configuring Advanced Port Options for CTP Bundles (CTPView) | 194
- Selecting the Type of Clocking on Serial Ports for CTP Bundles (CTPView) | 196
- Configuring Custom Clocking for CTP Bundles (CTPView) | 199
- Configuring Adaptive Clocking for CTP Bundles (CTPView) | 203
- Configuring PBS and Bridge Ports (CTPView) | 206
- Configuring Port Mirroring for CTP Bundles (CTPView) | 209
- Configuring NetRef Settings (CTPView) | 214

## 3

## Administration

- Activating, Disabling, Deleting, or Recentering CTP Bundles | 218**
  - Activating, Disabling, Deleting, or Recentering CTP Bundles (CTPView) | 218
  - Activating, Disabling, Deleting, or Recentering for CTP Bundles (CTP Menu) | 218
- Querying CTP Bundles | 220**
  - Displaying the Running CTP Bundle Configuration, State, and Counters (CTP Menu) | 220
  - Displaying the NetRef Node Synchronization Information (CTP Menu) | 232
  - Displaying Running CTP Bundle Configuration, State, and Counters (CTPView) | 234
- Monitoring Packet Creation and Reception and Packet Delay | 247**

Using SCC Counts to Monitor Packet Creation and Reception for CTP Bundles (CTP Menu) | 247

Using Buffer Sampling to Monitor Packet Delay for CTP Bundles (CTP Menu) | 249

Searching for Bundles Based on Bundle Description from CTPView | 250

### **Diagnostic Testing for CTP Bundles Overview | 251**

Serial Loops for CTP Bundles Overview | 251

BERT Testing for CTP Bundles Overview | 253

End-to-End BERT for CTP Bundles Overview | 254

### **Configuring and Displaying Diagnostic Testing for CTP Bundles | 256**

Configuring Serial Loops for CTP Bundles (CTP Menu) | 256

Configuring Serial Loops for CTP Bundles (CTPView) | 257

Configuring BERT Testing for CTP Bundles (CTP Menu) | 258

Configuring BERT Testing for CTP Bundles (CTPView) | 260

Displaying BERT Status and Counters for CTP Bundles (CTP Menu) | 262

Displaying BERT Status and Counters for CTP Bundles (CTPView) | 264

### **Reducing the Number of SNMP Traps Generated for Late and Missing Packets | 266**

Reducing the Number of SNMP Traps Generated for Late and Missing Packets (CTP Menu) | 266

## 4

### **Troubleshooting**

Knowledge Base | 269

# About This Guide

Software for CTP Series, CTPOS 7.3 and CTPView 7.3

## RELATED DOCUMENTATION

Using Bundles to Create Logical Configurations for Physical Interfaces



# 1

PART

## Overview

---

[Using Bundles to Create Logical Configurations for Physical Interfaces Overview](#) | 2

[CTP Bundle Overview](#) | 7

[Transparent Encoding Overview](#) | 22

[TDM/TDC Encoding Overview](#) | 30

[Ethernet Media Configuration Overview](#) | 37

---

# Using Bundles to Create Logical Configurations for Physical Interfaces Overview

## IN THIS CHAPTER

- [Types of Bundles Overview | 2](#)
- [Interface Naming Conventions for the CTP Series | 5](#)

## Types of Bundles Overview

[Table 1 on page 3](#) shows the typical application for each bundle type, and lists the interfaces that each type of bundle supports.

**NOTE:** Starting in CTPOS Release 9.1R3, the T1/E1 Daughter card is not supported in CTP150, CTP151, and CTP2000. If the Daughter card is present in these devices, then you will get an error message "System is unusable Reason: 1) Unsupported T1E1/IRIG/4WTO Dcard" when you use CTP nodes. Remove the Daughter card to access the node.

Table 1: Bundle Types and Supported Interfaces

Bundle Type	Generally Used For	Interface Types Supported
CTP (circuit-to-packet)	Connecting legacy serial interfaces to the IP network	<ul style="list-style-type: none"> <li>• CTP150 <ul style="list-style-type: none"> <li>• Serial interface</li> <li>• Multiservices interface</li> <li>• T1/E1 interface</li> </ul> </li> <li>• CTP2000 <ul style="list-style-type: none"> <li>• Multiservices interface</li> <li>• Serial interface</li> <li>• Serial interface with T1/E1 daughter card (Not supported from CTPOS 9.1R3 Release)</li> <li>• Serial interface with 4WTO daughter card</li> <li>• Serial interface with IRIG-B daughter card</li> <li>• T1/E1 interface</li> </ul> </li> </ul>
SATO P (structure-agnostic TDM over IP)	Connecting single T1 or E1 interfaces to an IP network	<ul style="list-style-type: none"> <li>• CTP150 <ul style="list-style-type: none"> <li>• T1/E1 interface</li> </ul> </li> <li>• CTP2000 <ul style="list-style-type: none"> <li>• Serial interface with T1/E1 daughter card (Not supported from CTPOS 9.1R3 Release)</li> <li>• T1/E1 interface</li> </ul> </li> </ul>

Table 1: Bundle Types and Supported Interfaces (*Continued*)

Bundle Type	Generally Used For	Interface Types Supported
CESoPSN (circuit emulation services over a packet-switched network)	Grouping multiple DS0s to one IP circuit	<ul style="list-style-type: none"> <li>• CTP2000               <ul style="list-style-type: none"> <li>• T1/E1 interface—digital voice or data</li> <li>• FXS interface (starting from CTPOS release 7.0)</li> <li>• FXO interface (starting from CTPOS release 7.0)</li> <li>• 4W-E&amp;M interface (starting from CTPOS release 7.0)</li> </ul> </li> <li>• CTP150               <ul style="list-style-type: none"> <li>• T1/E1 interface—digital voice or data</li> <li>• Serial interface—Nx64Kbps (starting from CTPOS release 6.6)</li> <li>• 4WTO analog audio interface—1 or 2 audio channels (starting from CTPOS release 7.3R7)</li> </ul> </li> </ul>
VComp (voice compression)	Grouping multiple analog circuits (channels) into one IP circuit (IPv4 only)	<ul style="list-style-type: none"> <li>• CTP2000               <ul style="list-style-type: none"> <li>• T1/E1 interface</li> <li>• 4W-E&amp;M interface</li> <li>• Voice compression module</li> <li>• FXS interface</li> <li>• FXO interface</li> </ul> </li> </ul>

## Interface Naming Conventions for the CTP Series

In the CTP software, interfaces are specified in the format:

*type-slot/port*

where

***type***        Type of interface. A two-character abbreviation.

***slot***         Slot number on the CTP device.

***port***         Port number on the CTP device.

If the interface module has a daughter card installed, the interface format is as follows:

*type-slot/port w/daughter-card*

**Table 2: Interface Type Specifiers**

Interface Type	Type Specifier
4WE&M	4w
4WTO	4w
E1	e1
2W-FXO	fo
2W-FSX	fs
IRIG	irig
Serial	se
T1	t1

**Table 2: Interface Type Specifiers** *(Continued)*

Interface Type	Type Specifier
T1E1	t1e1

# CTP Bundle Overview

## IN THIS CHAPTER

- [Adaptive Clocking Overview for CTP Bundles | 7](#)
- [Determining Optimal Packet Size for CTP Bundles Overview | 8](#)
- [Providing QoS for CTP Bundles by Using Service Type Overview | 11](#)
- [Circuit Startup Process Overview | 13](#)
- [Network Node Reference Overview | 14](#)
- [Support for Multiple Primary Nodes to Associate With a Single Member Node in NetRef | 15](#)
- [Loss of Signal Detection Capability on CTP Bundles and SAToP Bundles | 17](#)
- [Guidelines for Configuring LOS Detection | 20](#)

## Adaptive Clocking Overview for CTP Bundles

The goal of adaptive clocking is to prevent buffer anomalies by adjusting the clocks so that they are the same at each end of the network. If the clocks are not the same at each end of the network, the data rate entering and exiting buffers will not be the same, which causes a buffer underflow or overflow.

Adaptive clocking works by gathering information about packets arriving from the IP network and using that information to determine whether adjustments need to be made to the local clock to maintain frequency lock with the remote end. This process is called adaptive time domain processing (ATDP). ATDP provides rapid convergence to the correct clock, and does not vary due to changes in the average *jitter* buffer fill. As a result, a circuit continuously operates without a buffer recenter, even when clock references are not used.

There are two types of adaptive clocking:

- Adaptive clocking with internal clock—Recovers the clock from the user equipment connected to the remote CTP device and uses it to generate both transmit and receive timing. All clocking is performed by the DDS, which is initially configured to be locked to the local system clock. When packets begin to flow between the CTP devices, the adaptive clock begins time domain analysis of the packets that arrive from the remote CTP device. Based on this analysis, adjustments are made to the DDS clock to approximate the frequency of the clock used to create network-bound packets on

the remote CTP. In this way, the local CTP port can maintain long-term frequency lock with the remote CTP and pass this clock to the locally connected user equipment.

- Adaptive clocking with external TX clock—Data received from the local user equipment that is bound to the IP network is clocked using the CTP external user clock (the transmit timing clock). Data received from the remote CTP device and bound for the interface is adaptively clocked with the recovered clock from the user equipment connected to the remote CTP device. This configuration allows for independent adaptive configuration in each direction. With this method, the user equipment can send packets into the network with their local clock, and the remote end CTP devices adaptively recover this clock. This clocking method is useful when the port speed is high or the cable length between the user equipment and CTP device is large.

## RELATED DOCUMENTATION

[Configuring Adaptive Clocking for CTP Bundles \(CTP Menu\) | 110](#)

[Configuring Adaptive Clocking for CTP Bundles \(CTPView\) | 203](#)

## Determining Optimal Packet Size for CTP Bundles Overview

### IN THIS SECTION

- [Bandwidth for Transporting Serial Data | 9](#)
- [Packet Creation Delay | 9](#)
- [Performance of the IP Network | 10](#)

You can specify the size of IP packets that are created from data received at the serial port. The CTP device uses packet size along with the serial interface rate to calculate the packet rate; that is, the rate that packets are created. The maximum packet rate is 1500 packets per second.

To determine the optimal packet size, consider the following:

- Bandwidth for transporting serial data
- Packet creation delay
- Performance of the IP network



For example, larger packet sizes are more bandwidth-efficient, but introduce more delay during packet creation.

## Bandwidth for Transporting Serial Data

When considering bandwidth in relation to deciding packet size, add overhead for both the Layer 2 encapsulation and the IP header. The IP header comprises 20 bytes; and the encapsulation overhead varies, but is typically either 6 or 8 bytes on serial links. This overhead causes smaller packets to be less efficient and result in serial data requiring more bandwidth.

Calculate the bandwidth required for a serial bit stream as follows:

$$\text{IP Bandwidth} = [\text{Packet Size (bytes)} + 20 \text{ (bytes)} + 2 \text{ (bytes)} + \text{Encapsulation Overhead (bytes)}] \times [\text{Packet Rate (pps)}] \times 8$$

## Packet Creation Delay

Serial data received at the CTP interface must be buffered long enough to allow a packet to be created. The delay to create the packet increases as either the size of the packet increases or as the rate of the serial interface decreases. Generally, this delay is minimal except when the rate of the serial interface is low and the packet size is large. We recommend that you set the packet size to a smaller value for lower-speed serial interfaces. [Table 3 on page 9](#) provides examples of serial interface packet creation delay in milliseconds.

**Table 3: Packet Creation Delay for Serial Interfaces**

	Serial Interface Delay (msec)					
	Packet Size (bytes)					
Interface Rate (Kbps)	128	256	512	768	1024	1400
64	16.0	32.0	64.0	96.0	128.0	175.0
128	8.0	16.0	32.0	48.0	64.0	87.5
256	4.0	8.0	16.0	24.0	32.0	43.8
1024	1.0	2.0	4.0	6.0	8.0	10.9

Table 3: Packet Creation Delay for Serial Interfaces *(Continued)*

	Serial Interface Delay (msec)					
	Packet Size (bytes)					
Interface Rate (Kbps)	128	256	512	768	1024	1400
1544	0.7	1.3	2.7	4.0	5.3	7.3
2048	.5	1.0	2.0	3.0	4.0	5.5

## Performance of the IP Network

The number of packets created (packet rate) is inversely related to the packet size configured. For example, smaller packets result in a greater packet rate. When you configure the packet size, consider the packet-forwarding performance of the attached router and network. [Table 4 on page 10](#) provides examples of packet rates for various packet sizes and serial interface rates.

Table 4: Packet Rate for Various Packet Size and Serial Interface Rate Settings

	Packet Rate (Packets per Second)					
	Packet Size (Bytes)					
Interface Rate (Kbps)	128	256	512	768	1024	1400
64	62.5	31.3	15.6	10.4	7.8	5.7
128	125.0	62.5	31.3	20.8	15.6	11.4
256	20.0	125.0	62.5	41.7	31.3	22.9
1024	1000.0	500.0	250.0	166.7	125.0	91.4
1544	1507.8	753.9	277.0	251.3	188.5	137.9

Table 4: Packet Rate for Various Packet Size and Serial Interface Rate Settings (*Continued*)

	Packet Rate (Packets per Second)					
	Packet Size (Bytes)					
Interface Rate (Kbps)	128	256	512	768	1024	1400
2048	2000.0	1000.0	500.0	333.3	250.0	182.9

## RELATED DOCUMENTATION

[Configuring IP Parameters for CTP Bundles \(CTP Menu\) | 41](#)

[Configuring IP Parameters for CTP Bundles \(CTPView\) | 140](#)

## Providing QoS for CTP Bundles by Using Service Type Overview

In IP networks, the IP flow is typically classified based on the Differentiated Services Code Point (DSCP) setting in the type of service (TOS) byte of the IP header. DSCP is a scalable solution for classifying flows in a large IP network based on the *class of service* desired on specific IP traffic flows.

With the CTP device, you can configure DSCP settings for each circuit's IP flow. For example, some circuits could be configured for the expedited forwarding (EF) class. When the network routers receive this EF-marked flow from the CTP device, they place the marked traffic into a high-priority queue, enabling this traffic to be serviced before lower priority traffic. As an EF-marked flow traverses the IP network, routers can use its classification to provide the flow a more predictable level of performance across the network.

When you configure the service type of a bundle, you specify the ToS byte to be used in IP headers of packets sent from the CTP device to the IP network. The ToS setting is applied to circuits created by the bundle for which the service type is configured.

[Table 5 on page 12](#) shows the mapping for each DSCP class and setting to the ToS setting that you configure as the service type for a bundle. The EF class (ToS setting 184) is commonly used for circuit traffic.

Table 5: DSCP Classes and Service Type

DSCP Class	DSCP Setting	ToS Setting
CS7	56	224
CS6	48	192
EF	46	184
CS5	40	160
AF43	38	152
AF42	36	144
AF41	34	136
CS4	32	128
AF33	30	120
AF32	28	112
AF31	26	104
CS3	24	96
AF23	22	88
AF22	20	80
AF21	18	72
CS2	16	64

Table 5: DSCP Classes and Service Type *(Continued)*

DSCP Class	DSCP Setting	ToS Setting
AF13	13	52
AF12	12	48
AF11	10	40
CS1	8	32

## RELATED DOCUMENTATION

[Configuring IP Parameters for CTP Bundles \(CTP Menu\) | 41](#)

[Configuring IP Parameters for CTP Bundles \(CTPView\) | 140](#)

## Circuit Startup Process Overview

CTP devices use UDP operational and maintenance (OAM) packets to initially discover the circuit on the remote CTP device, and to verify continued connectivity with the remote device. When a bundle is activated, the CTP device sends OAM packets to the remote circuit until the required number of packets is received. The circuit then changes its state to in-sync, and begins sending data packets.

Circuits continue to send OAM packets to the remote device at a configured rate. If the number of OAM packets that the CTP devices misses reaches a configured number, the state of the circuit changes from in synchronization to no synchronization.

You can also specify how many consecutive packets the IP network must drop before the CTP device restarts the circuit. After the circuit restarts, the CTP device must receive a specified number of in-sequence packets before it transitions the circuit from in-sync to running.

## RELATED DOCUMENTATION

[Configuring Circuit Startup Parameters for CTP Bundles \(CTPView\) | 143](#)

[Configuring Circuit Startup Parameters for CTP Bundles \(CTP Menu\) | 44](#)

## Network Node Reference Overview

### IN THIS SECTION

- [Guidelines for Configuring NetRef | 14](#)

Network node reference (NetRef) is an extension of the CTP adaptive port clocking. NetRef can be used to provide node level synchronization across a network. NetRef is supported in CTPOS release 5.4R1 and later.

NetRef operates in two modes.

- Primary or backup operation— When NetRef is configured for primary or backup operation, the primary node sends clocking information to the backup node. The backup node uses an algorithm similar to that used for adaptive port clocking to control the local node clock so that it follows the clocking of the remote node. To operate in primary or backup mode, the remote primary node must be configured as a NetRef primary node with the IP address of the NetRef client configured. The backup node must be configured as a NetRef backup node with the IP address of the NetRef primary node configured.
- Adaptive bundle operation— Normally, the adaptive clocking algorithm is used to control the port clock, but when NetRef is configured for adaptive bundle operation, the adaptive clocking algorithm instead controls the node clock. The clocking for the whole node is then derived from the clock that drives the remote port. If the remote port is configured for TT, then the local node is clocked to the remote port's external clock. If the remote port is configured for configured rate, then the local node clock is derived from the remote node clock.

When a node is configured for NetRef backup or adaptive bundle operation, all the external references must be disabled. If timing packets stop arriving at a NetRef backup node, the backup node waits until packets start arriving again to make any clock adjustments. When the packets start arriving again, NetRef transitions to **Wait** state, waits for 16 packets, and then transitions to the **Aggressive** state. The LED becomes red when NetRef is in **Wait** or **Aggressive** state. The LED is green when NetRef is in **Maintain** state.

### Guidelines for Configuring NetRef

- You can configure the NetRef adaptive parameters from the port menu. However, you cannot modify the adaptive parameters of a NetRef backup node.

- If a CTP bundle is already configured between the two nodes, using NetRef adaptive bundle operation does not add to the network traffic between the nodes.
- Though NetRef is supported only on CTPOS 5.4R1 and later, it supports remote nodes running earlier CTPOS versions. No special configuration needs to be made on the remote node.
- The maximum number of backup nodes that a NetRef primary node can have is limited to 10. However, there is no limit on the number of backup nodes for the NetRef adaptive bundle operation.
- Adaptive bundle operation depends on the bundle state and requires a CTP bundle between the nodes. The node synchronization process stops if the bundle comes down. NetRef primary operation does not need a CTP bundle between the nodes.

## RELATED DOCUMENTATION

[Configuring NetRef for Adaptive Bundle Operation | 124](#)

[Configuring NetRef for Primary or Backup Operation | 125](#)

## Support for Multiple Primary Nodes to Associate With a Single Member Node in NetRef

Network node reference (NetRef) is an extension of the CTP adaptive port clocking. NetRef can be used to provide node level synchronization across a network. When NetRef is configured for primary or backup operation, the primary node sends clocking information to the backup node. The backup node uses an algorithm similar to that used for adaptive port clocking to control the local node clock so that it follows the clocking of the remote node. To operate in primary or backup mode, the remote primary node must be configured as a NetRef primary node with the IP address of the NetRef client configured. The backup node must be configured as a NetRef backup node with the IP address of the NetRef primary node configured. You can configure up to four primary nodes, each of which can send their clocking information to a maximum of 10 slaves and the client node can receive clocking information from the configured primary nodes.

You can configure the four primary nodes using CTP Menu or the CTPView web server during Netref client configuration. As a result, a single client node can use the IP address of up to four primary nodes while you configure Netref client node settings.

Each primary node is assigned a priority during Netref client configuration. The primary node with the highest priority is assigned Priority 1, the second highest priority for the primary node is Priority 2, and so on. You cannot configure the priority of the primary nodes. The priorities assigned are unique for each primaries while configuring Netref client nodes. The client nodes synchronize their local clock with the clock of the highest priority primary node (Priority 1 primary node). After the highest priority

primary goes down or when a problem occurs during the clock synchronization phase, the CTP device switches to its next highest priority primary (Priority 2 primary node). The client nodes synchronize their clock with the clock of Priority 2 primary node. The priorities of the primary nodes are also switched in the backend, after switching of the primary nodes takes place. In the case of flapping between the primaries, the primary (high priority) is retained or binding with the primary that contains a good clock quality is maintained.

When switching of the primaries takes place, an event of primary role change is logged into the syslog messages. The client node synchronization query provides the details of the primary node to which the client is locked and the details of the configured primary nodes along with their assigned priorities. You cannot configure the lowest priority primaries until its higher priority primaries are configured. Similarly, you cannot disable the highest priority primaries until its lower priority primaries are disabled.

When a node is configured as NetRef Primary, it starts generating the NetRef packets and send them to the client nodes. The client node accepts the packets from the highest priority primary node and the NetRef state of the client node is changed to wait state. If 16 sequenced packets are received by the client nodes, the NetRef state is changed from **Wait** state to **Aggressive** state. At this stage, if 8 packets are missed continuously, the NetRef state again moves back to the **Wait** state. These NetRef packets are processed and slope is calculated. Based on the slope, the clock of the client node is in synchronization with the primary node and the state changes to the **Maintain** state. The state changes from **Maintain** or **Aggressive** to **Starvation** when no NetRef packet is received in last 20 seconds. As soon as the node goes to **Starvation** state, switching of the primary takes place. The packets are processed by the client nodes to synchronize their clock with the next highest priority primary node. Flapping of the primaries occurs if you continuously “round robin” to each primary and wait for 20 seconds for an incoming NetRef packet.

The LED becomes red when NetRef is in **Wait** or **Aggressive** state. The LED is green when NetRef is in **Maintain** state. The switching of the primaries occurs as described in the following table:

Member Nodes	Assigned Priority	Assigned Priority After First Failure	Assigned Priority After Second Failure	Assigned Priority After Third Failure	Assigned Priority After Fourth Failure
Primary 1	1 (primary)	4	3	2	1 (primary)
Primary 2	2	1 (primary)	4	3	2
Primary 3	3	2	1 (primary)	4	3
Primary 4	4	3		1 (primary)	4



If all the four primary nodes goes down, the NetRef state remains in **Starvation** state and no switching will take place. When the NetRef state of the client node is **Maintain** and the primary goes down, the client node is unable to receive the packets within the last 20 seconds. Therefore, the NetRef state of the client node moves from **Maintain** state to **Starvation** state and switching takes place. When the NetRef state of the client node is **Aggressive** and the primary goes down, the client node is unable to receive the packets within the last 20 seconds. Therefore, the NetRef state of the client node transitions from **Aggressive** state to **Starvation** state and switching will take place.

When the NetRef state of the client node is in **Wait** state (waiting for NetRef packets from the primary node) and the primary node is disabled but the secondary primary nodes are sending NetRef packets to the client node, switching will take place.

Revert option is not supported; when the primary node comes up, the client node remains locked to the secondary primary node and does not become locked to the primary node.

Without multiple primary nodes support, when a node is configured as client, the node www\_db string is

```
"23;1;0;0;0;0;0;0;0;5;1;5;1;5;1;5;1;5;1;5;1;2|64|
127.0.0.1/127.0.0.1/127.0.0.1/127.0.0.1/127.0.0.1/127.0.0.1/127.0.0.1/127.0.0.1/127.0.0.1/127.0.0.1/127.0.0.1/|0|255|;0;"
```

This www\_db string is not different when multiple primary nodes are configured for a backup node. The first IP address in the www\_db string contains a priority of 1, the second contains a priority of 2, and so on, as shown as follows:

```
"23;1;0;0;0;0;0;0;0;5;1;5;1;5;1;5;1;5;1;5;1;2|64|
10.216.118.73/10.216.118.86/10.216.118.90/10.216.118.88/127.0.0.1/127.0.0.1/127.0.0.1/127.0.0.1/127.0.0.1/|0|
255|;0;"
```

When node is configured as master, the node www\_db string will remain same as it is there in the earlier releases.

## Loss of Signal Detection Capability on CTP Bundles and SAToP Bundles

### IN THIS SECTION

- [Detection of LOS on Serial Interfaces | 19](#)
- [Detection of LOS on T1/E1 Interfaces | 19](#)

A loss of signal (LOS) alarm indicates that there is a physical link problem with the connection to the router receive port from the neighboring SONET equipment transmit port. An LOS alarm occurs when

the port on the card is in service but no signal is being received. The cabling is not correctly connected to the ports, or no signal exists on the line. Possible causes for a loss of signal include upstream equipment failure or a fiber cut.

The CTP devices support a both-ended redundancy mechanism, in which two identical CTP circuit bundles are combined using Y cables at each end, enabling one bundle to act as a backup for the other. One of the bundles is in use (online), while the other is in the standby state (offline). Only the online bundle is allowed to drive the Y cable towards the user equipment, while the offline bundle is tristate. A communications channel (such as redundancy by using a hardware link that uses a special Y cable or redundancy based on a software link that does not depend on a signaling hardware like the Y cable) between ports at each end determines which of the two ports on the Y cable is currently online. When one bundle fails, the failed bundle transitions to the offline and places the other bundle in the online state.

Consider a sample configuration scenario in which two CTP bundles (four CTP ports) are used in a Y-cable redundancy format. Software-based redundancy is enabled. In this type of configuration, 172.25.62.51:te-0/0(B0) is the left primary link and 172.25.62.51:te-0/1(B1) is the left secondary link. 172.25.62.52:te-0/0(B0) is the right primary link and 172.25.62.52:te-0/1(B1) is the right secondary link. In this redundant configuration, the circuit is very robust, protecting against many types of failures, such network failures, power failures, and equipment failures. However, one type of failure is not detected, which is when a cable is pulled out.

Starting with CTPOS Release 7.2R1, CTP devices support the detection of a loss of signal, which denotes a physical link problem. The following conditions are supported:

- In a serial both-ended Y-cable redundancy configuration (software-based Y cable link protocol), removal of Y cable leg from the CTP port of the online bundle must be able to force a switch to the standby bundle.
- In a T1/E1 both-ended Y cable configuration (software-based Y cable link protocol), removal of Y cable leg from the CTP port of the online bundle must be able to force a switch to the standby bundle.

The T1/E1, CTP, and SAToP bundles support LOS detection and based on this signal, the run state of the bundles switches to TfFail, which initiates a software-based Y cable switchover to a redundant port. Also, for T1/E1 both-ended Y-cable redundancy configuration, only software-based Y cable link protocol is supported and hardware-based redundancy is not supported.

The way in which CTP redundancy works is by using the bundle state to make decisions. When a bundle is in the RUNNING state, the following processes occur:

1. The remote CTP is operational and is able to generate and send packets into the IP network (towards us).
2. The network is able to transport bundle OAM and payload packets from the remote CTP to the local CTP.

3. A sufficient percentage of the bundle payload packets fills packet delay variation (PDV buffers) and maintain circuit data transport towards the locally connected user equipment.

Therefore, when a bundle is in the RUNNING state, it is “usable” and can be online in a redundant configuration.

Consider a network topology in which a failure occurs in the circuit path that does not cause the circuit to exit the RUNNING state. This phenomenon can be the case when the cable is pulled from the CTP port of a redundant online bundle. Although this condition might not typically be considered an actual failure, and instead more of a configuration error, this symptom can nevertheless be classified in the failure category. Therefore, a mechanism to be able to detect this condition in redundant setups and provide an online circuit switch to offline when the cable is removed is beneficial. CTP devices support the evaluation of LOS conditions on serial interfaces and T1E1 interfaces in CTP bundles and SAToP bundles.

### **Detection of LOS on Serial Interfaces**

For serial interfaces, the determination of LOS condition is already performed in CTPOS releases earlier than Release 7.2R1. When a serial circuit is configured to use the TT input (on a data communication equipment [DCE] interface) for at least one of its five configured port clocks (for example, “Cfg Rate - Ext Clk), the external clock frequency is examined by the CTP device before the local bundle can go to the running state. If there is no external clock present or it is not the correct frequency, then the bundle transitions to the TtFAIL state and never go to RUNNING. Also, if the bundle is already in the RUNNING state, the external clock is verified every second to ensure that its frequency is still present and within range. If not, the bundle transitions from RUNNING to TtFAIL.

In the TtFAIL state, the bundle periodically transitions back to the EVAL state, where the external clock is checked again. If the clock fails or a bad frequency occurs, the bundle returns to the TtFAIL state. If the clock is properly functional, then the bundle transitions to the various states that eventually end in the RUNNING state. Such a method of change of states enable a graceful (if not instantaneous) recovery of a circuit where a cable is disconnected, but subsequently reconnected. Because removal of the cable on a serial port that is using an external clock can cause the bundle to exit the RUNNING state, that bundle switches offline, if currently online in a Y-cable redundancy setup.

### **Detection of LOS on T1/E1 Interfaces**

The clock and data signals are embedded together on a T1/E1 interface in a single AMI (alternate mark inversion) electrical signal. The hardware line interface unit (LIU) that recovers the composite AMI signal into its component clock and data signals recovers a clock from the incoming AMI signal, even when none is present because it is based on a free running phase-locked loop (PLL) that generates a clock, even when it is not locked to an incoming signal. As a result, the CTP port interface receives an incoming external clock from the LIU, whether a valid T1/E1 signal is connected to the CTP or not. The LIU, however, cannot determine when it has a valid incoming T1/E1 signal, and in such a condition, the LIU

indicates as a LOS status bit. This indication serves as the basis for detecting a cable disconnect in a Y-cable redundant configuration.

To use LOS as a way to take down a RUNNING bundle, the effective method implemented is to treat a T1/E1 LOS condition exactly the same as a serial port with a bad or missing external clock. When the CTP device performs its “check external clock” function, instead of returning an automatic success on T1/E1 ports, the LOS status bit is analyzed to determine whether it is a T1/E1 port. If the LIU LOS status indicates that there is no incoming signal, then the function returns a failure, which causes the bundle to move to the TtFAIL state. This state is the same as a missing external clock processing for a serial port. In this manner, the T1/E1 ports behave exactly the same way as serial ports.

## Guidelines for Configuring LOS Detection

Keep the following points in mind when you configure the capability to detect LOS conditions on T1E1 interfaces:

- A cable disconnection of a serial port cannot be detected when no external clock is being used by the port. The following clock configurations use an external clock:
  - DCE/DTE: Cfg Rate – Ext Clk
  - DCE/DTE: All Clock – Ext Clk
  - DCE/DTE: Adap Rate – Ext Clk
  - DCE/DTE: Auto Rate – Ext Clk
  - DTE: All clocked by Ext Clk (ST/RT)
  - DTE: All clocked by User Clk (RT)
  - Any custom clock config that uses “TT”
- For any other serial clock configuration, a cable removal on the online port does not cause it to exit the running state.
- For T1/E1 ports, the recovered clock (which is equivalent to the external clock of a serial port) from the incoming T1/E1 AMI signal is used in all available T1/E1 preconfigured or canned clock configurations.
- The T1 LOS checking technique was primarily intended for CTP bundles. Because the T1/E1 SAToP bundle state machine also supports the bundle EVAL state as part of its bundle state machine, it can also benefit from the LOS checking functionality provided by this feature. However, the LOS detection feature on SAToP bundles is not useful for both ended redundancy, since both-ended Y-cable redundancy configurations only supports CTP bundles.

- CESoPSN and VCOMP bundles are not supported for detecting LOS conditions because their bundle state machines do not support an EVAL state.
- You can configure the LOS detection mechanism for T1/E1 ports in the same function that checks the external input clock. In addition, this T1/E1 LOS detection capability is processed under the control of a separate port configuration flag so that this LOS checking occurs only when this flag is active. Although this menu option to enable or disable the LOS detection functionality is shown regardless of the port type, such as serial interfaces or T1E1 interfaces, this setting becomes effective on a T1/E1 port only when it is connected to a CTP or SAToP bundle. If the LOS detection functionality is enabled on a serial port or other bundle types, the setting is not processed.
- Also, when you run the bundle query for CTP bundles and SAToP bundles, the T1E1 port type displays port configuration flags that are relevant to a T1E1 port. In the PortConfigFlags field displayed in the output of the bundle query, T1LoSCheck denotes that LOS detection is specified on a T1 port connected to a CTP bundle or a SAToP bundle, E1LoSCheck denotes that LOS detection is specified on a E1 port connected to a CTP bundle or a SAToP bundle, and the NoRdReclk flag signifies that the redundancy receiving (RX) clock is disabled. The NoRdReclk flag is also displayed because this flag is default enabled for a T1/E1 port, whereas it is usually not enabled for a serial port.

# Transparent Encoding Overview

## IN THIS CHAPTER

- [Transparent Encoding Applications and Support Overview | 22](#)
- [How Basic Transparent Encoding Works | 23](#)
- [Using Phase-Correction FIFO Buffer with Transparent Encoding | 24](#)
- [Using Send Timing \(ST\) Clocking for Higher Speed Circuits with Transparent Encoding | 27](#)

## Transparent Encoding Applications and Support Overview

Transparent mode is for unique applications that require the data and clock signals to be sampled at one end of a circuit and replicated at the far end. For example, applications in which:

- Data rates are low (32 Kbps or less) and rates can vary over time. The sampling *jitter* prevents use of higher data rates.
- Data rates are low and fixed and/or low network latency is required.
- Clocks must disappear (transitions stop) periodically during circuit operation.

The transparent encoding scheme is supported only when you have worked with the Juniper Networks Technical Assistance Center (JTAC) to verify that your application requires this encoding scheme. You may need to use special adapters on the cable to properly map the data and clock signals to the connector pins that the application uses.

We recommend that you do not use transparent encoding in WAN environments because of its large consumption of bandwidth.

## RELATED DOCUMENTATION

---

[How Basic Transparent Encoding Works | 23](#)

---

[Using Phase-Correction FIFO Buffer with Transparent Encoding | 24](#)

---

[Using Send Timing \(ST\) Clocking for Higher Speed Circuits with Transparent Encoding | 27](#)

---

## How Basic Transparent Encoding Works

There are two modes of transparent encoding. They are Transparent 4 mode (TRANS) and Transparent 8 mode (TRANS8). Transparent 8 mode is supported only on CTPOS release 6.4 and later.

Transparent encoding mode 4 samples incoming data on four input signals (SD, TT, RTS, and DTR), transports these signals across the IP network to the remote end of the circuit, and sends the signals on four output signals (RD, RT, CTS, and DSR). [Figure 1 on page 23](#) shows a simplified model of a transparent encoded circuit.

**Figure 1: Simplified Model of a Transparent Encoded Circuit**

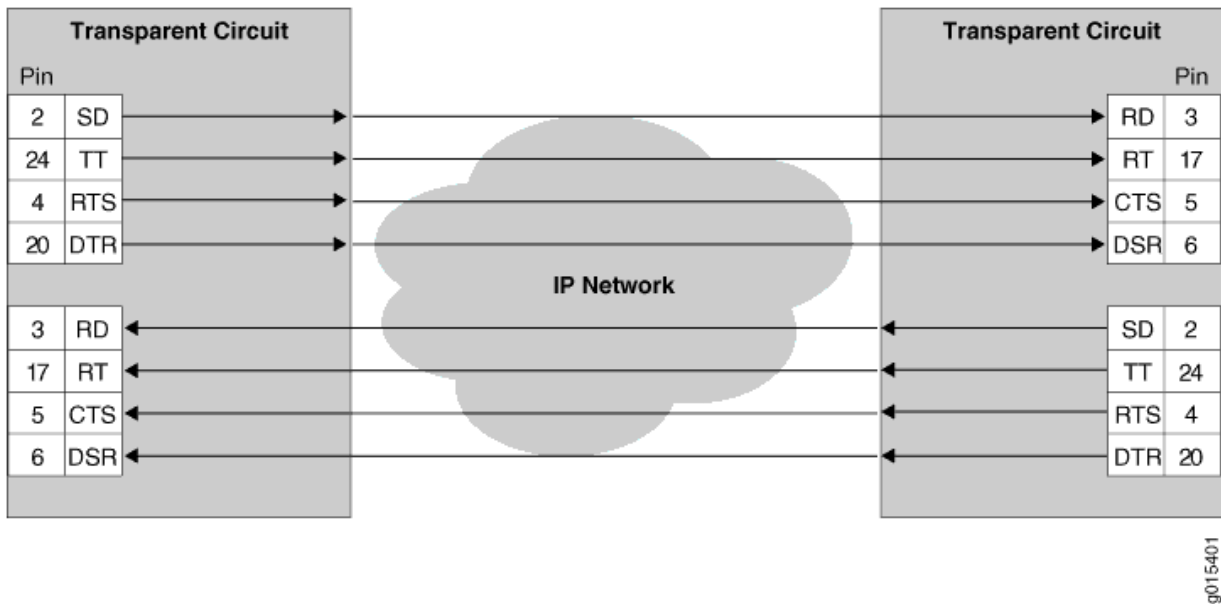

The signal sampling rate is based on the configured port rate. For example, if the port rate is 128 Kbps, then the four signals are sampled at 128 KHz, which generates a packet flow through the IP network of 512 Kbps (4 x 128 KHz). The smallest sampling rate available is 5.3 μsec (approximately 192 KHz).

To prevent errors in transport, both ends of the circuit must be synchronized with each other. You can achieve synchronization either by locking each CTP node to a common reference or by enabling adaptive clocking on one end of the circuit.

Transparent 8 encoding is an extension of Transparent 4 encoding. Compared with Transparent 4 encoding, which sends four signals in each direction, Transparent 8 encoding doubles the bandwidth and

g015401

allows eight signals to be sampled and transported. This allows signals to be sent from additional interfaces that were not supported in Transparent 4 encoding, although the bandwidth usage will be higher.

## RELATED DOCUMENTATION

---

[Transparent Encoding Applications and Support Overview | 22](#)

---

[Using Phase-Correction FIFO Buffer with Transparent Encoding | 24](#)

---

[Using Send Timing \(ST\) Clocking for Higher Speed Circuits with Transparent Encoding | 27](#)

---

[Configuring Transparent Encoding for CTP Bundles \(CTP Menu\) | 69](#)

---

[Configuring Transparent Encoding for CTP Bundles \(CTPView\) | 167](#)

## Using Phase-Correction FIFO Buffer with Transparent Encoding

The transparent encoding feature provides a phase-correction FIFO buffer. This FIFO buffer aligns the clock and data phase relationship on a transparent encoded circuit in which the clock travels in one direction through the network, and the data travels in the opposite direction. The transparent FIFO buffer is needed because of the latency of signal transport over the IP network.

[Figure 2 on page 25](#) shows the phase-correction FIFO buffers. You can enable the phase-correction FIFO buffer at either end of the circuit. You would not enable the FIFO buffer at both ends of the circuit.



Figure 2: Transparent Encoding with Phase-Correction FIFO Buffers

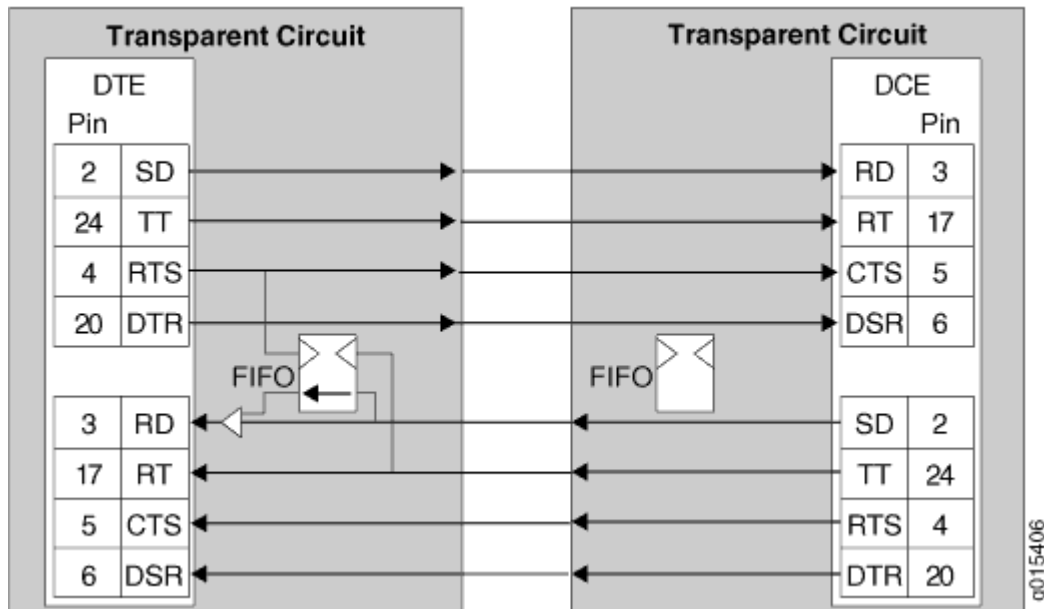
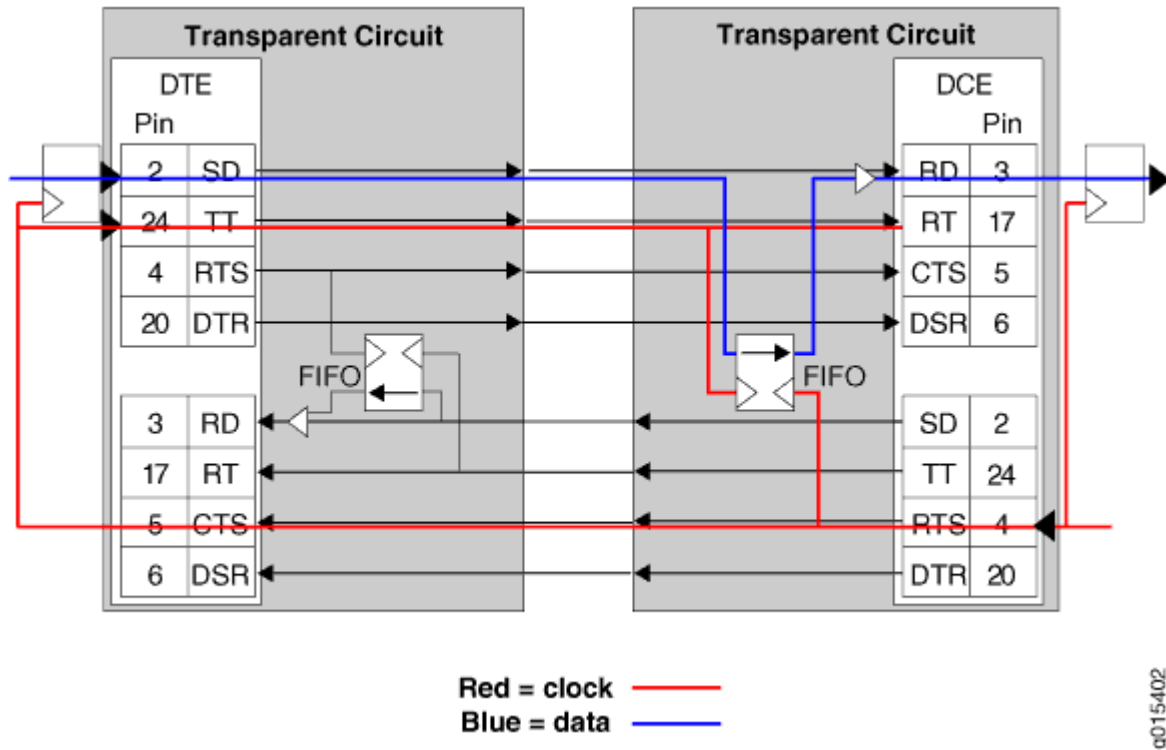

Figure 3 on page 26 shows the paths of the clock and data through the phase-correction FIFO buffer that is enabled on the transparent circuit on the right.

- The clock enters the network from the DCE, goes to the DTE, and then clocks data into the network on the DTE. The clock is also looped back on the DTE to enter the network in phase with the data as it travels from the DTE to the DCE.
- The data enters the FIFO buffer in phase with the clock passing through the network from the DTE to the DCE, while data is clocked out of the FIFO buffer with the clock that entered the network from the DCE, which is in phase with the user clock.

Figure 3: Clock and Data Paths with Transparent Phase-Correction FIFO Buffers



Like in TRANS encoding, you can use the 16 bit phase correction FIFO in TRANS 8 encoding to accommodate the problems that can be caused by the high latency in the circuit whether or not the remote DCE device can accept TT input or not.

When the customer DCE device can support the TT signal returned by the DTE, the phase correction FIFO is not needed. The DCE transmit clock (ST) is sampled and carried downstream to the DTE, where it is used to generate the upstream data that is sent back to the customer DCE. This clock data is also sent as the DTE transmit clock (TT) to travel along with the data in phase. When these signals get back to the customer DCE device, they are still in phase (same delay through the network), so the customer DCE can use the TT signal to recover the transmit data on the SD lead.

Consider a scenario in which the customer's upstream DCE does not use the TT signal for capturing upstream data, and instead uses the ST clock. Here, due to the latency of the ST clock traveling downstream and the time taken for the return trip of the data, it is difficult to ensure error-free data transport. In such a scenario, you can use phase correction FIFO to ensure error-free data transport.

The SD or TT clock and data signals get back to the upstream CTP device, where the data is clocked into the FIFO using the TT clock, which is in phase. This data is clocked out of the FIFO using the upstream ST clock, and the data is realigned to be in phase with the ST clock.

## RELATED DOCUMENTATION

[Transparent Encoding Applications and Support Overview | 22](#)

[How Basic Transparent Encoding Works | 23](#)

[Using Send Timing \(ST\) Clocking for Higher Speed Circuits with Transparent Encoding | 27](#)

[Configuring Transparent Encoding for CTP Bundles \(CTP Menu\) | 69](#)

[Configuring Transparent Encoding for CTP Bundles \(CTPView\) | 167](#)

## Using Send Timing (ST) Clocking for Higher Speed Circuits with Transparent Encoding

When the relationship between the clock and the data signals is critical, you can use ST clocking with transparent encoding to prevent delay and *jitter* in CTP2000 series devices, making it possible to carry higher speed circuits in transparent mode.

[Figure 4 on page 28](#) shows the issue of delay and jitter where a transparent encoded circuit connects a DCE to a DTE. The circuit is set up as follows:

- The high-speed clock and data lines (shown in red) are aligned by a FIFO buffer at the DCE.
- The signaling leads (shown in blue) are passed end-to-end without going through the FIFO buffer. The signaling paths that carry non-timing-critical signals are subject to delay and jitter.

The problem is that when a FIFO buffer is used at one end of the circuit, an additional clock path from the DCE to the DTE is needed to carry a clock to the DTE so that it can return a DTE-to-DCE clock that is in phase with the data. This DTE-to-DCE clock is needed to clock the FIFO input. Normally, one of the signal lead paths carries this transmit clock. However, when the circuit is running at speeds above 32k, the delay and jitter on these paths make these signal choices nonoptimal.

Figure 4: High-Speed and Low-Speed Paths with Transparent Encoding

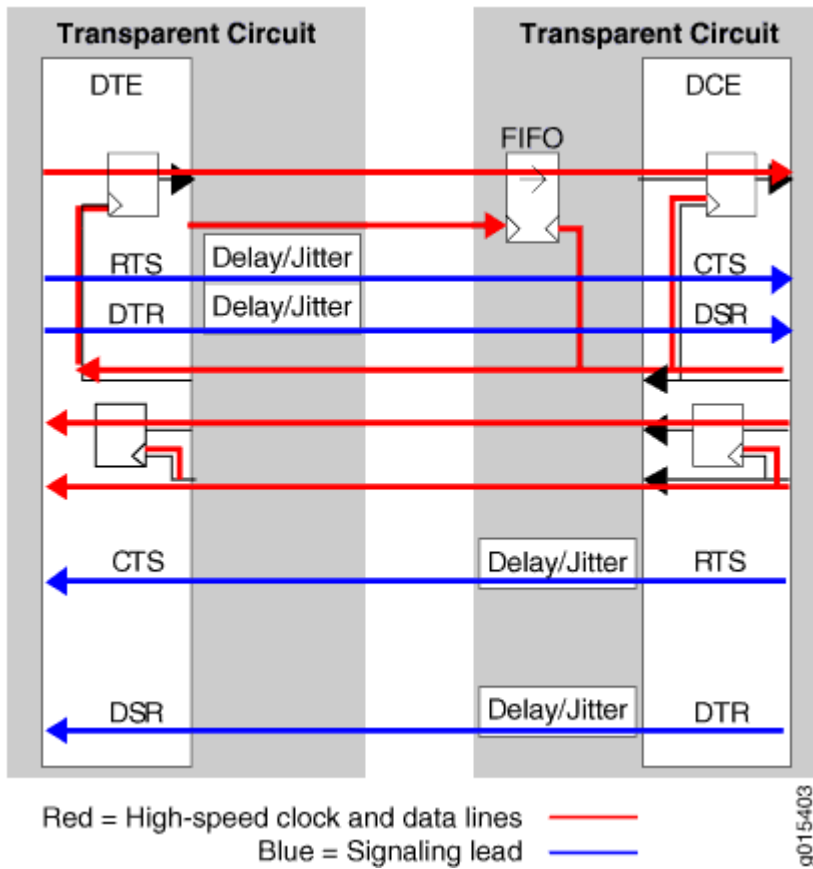

To solve the issue of delay and jitter associated with the signaling leads, you can use the ST interface signal to feed or sink the RTS-to-CTS signal path. By using the ST interface signal instead of the RTS-to-CTS signal path, delay and jitter are removed from that signal path. [Figure 5 on page 29](#) shows a transparent-encoded circuit with the additional ST functionality:

- At the DCE, the RTS-to-CTS signal path is configured to use ST (as an input from the DCE) to feed that signal path through the network.
- At the DTE, that signal is placed onto the ST lead, which is configured as an output.

Figure 5: Transparent Encoding Using ST Clcking

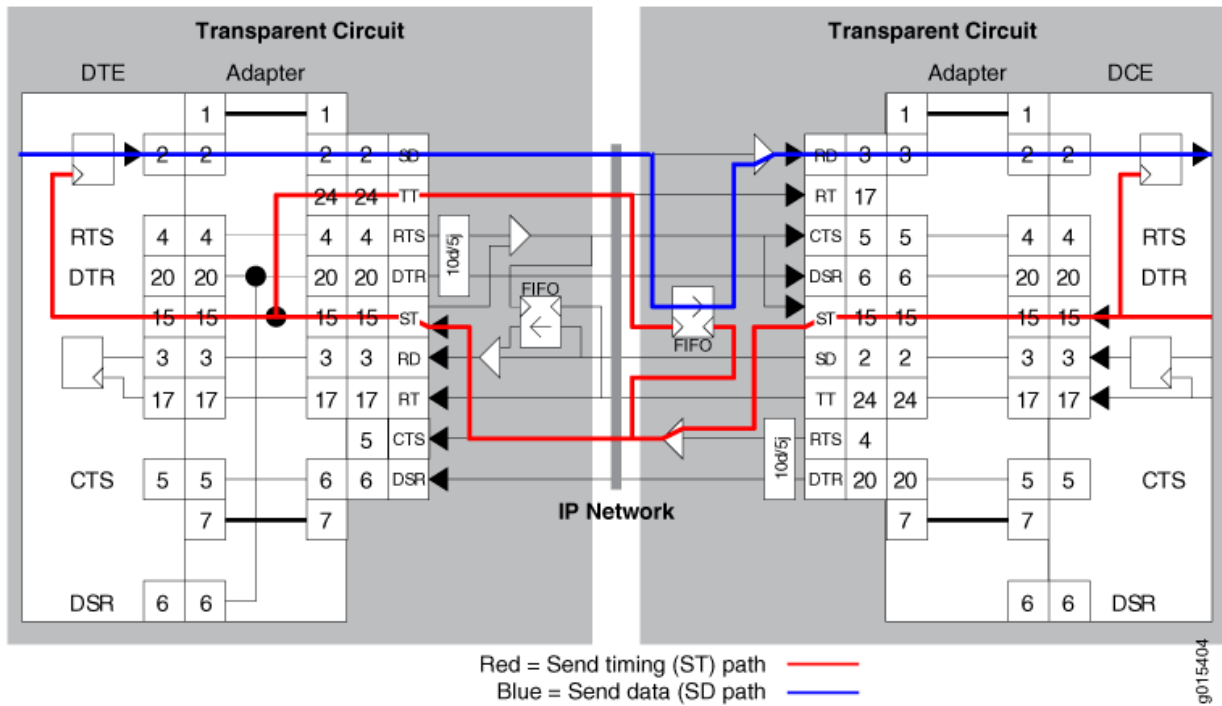

When you configure transparent encoding to use the ST lead instead of RTS/CTS, you can specify whether or not ST is an input lead.

## RELATED DOCUMENTATION

[Transparent Encoding Applications and Support Overview | 22](#)

[How Basic Transparent Encoding Works | 23](#)

[Using Phase-Correction FIFO Buffer with Transparent Encoding | 24](#)

[Configuring Transparent Encoding for CTP Bundles \(CTP Menu\) | 69](#)

[Configuring Transparent Encoding for CTP Bundles \(CTPView\) | 167](#)

# TDM/TDC Encoding Overview

## IN THIS CHAPTER

- [TDM/TDC Encoding Overview | 30](#)

## TDM/TDC Encoding Overview

### IN THIS SECTION

- [How TDM Interleaving Works | 30](#)
- [How the CTP Implementation of TDM/TDC Works | 32](#)
- [TDM Rates | 33](#)
- [TDM High-Speed and Low-Speed Ports | 34](#)

The time domain correlation (TDC) feature uses time division multiplexing (TDM) to interleave multiple data types on serial ports so that the CTP device can bond two circuits into a single data stream. Doing so allows the CTP device to carry two independent data streams on the same path through the IP network. Out of each set of 32 bits in the IP data stream, you can designate a certain number of bits for TDM functions.

The TDM/TDC feature is commonly used for telemetry applications, and is supported on CTP2000 serial interfaces.

### How TDM Interleaving Works

When TDM is not being used, all 32 bits in the IP data stream transport serial data on a port. For example, [Figure 6 on page 31](#) shows all 32 bits being allocated to local serial port data as indicated with the D.



When you enable TDM, a specific number of the 32 data bits are allocated for another function. That is, another function is interleaved with the serial data. For example, in [Figure 7 on page 32](#) half of the bits (16 bits in 32) are allocated to serial port data (as indicated by D), and half of the bits are allocated to TDM (as indicated by T).

**Figure 7: Serial Port Bit Allocation With 16 Bits Allocated to TDM**

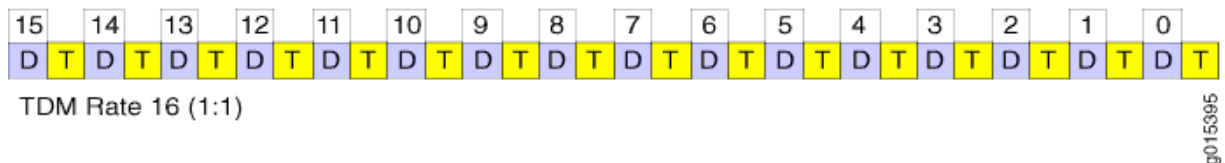

The number of bits out of 32 that are allocated to TDM is called the TDM rate. [Figure 7 on page 32](#) showed a TDM rate of 16. [Figure 8 on page 32](#) shows the bit allocation for TDM rates of 2, 4, and 8.

**Figure 8: Bit Allocation for TDM Rates of 2, 4, and 8**

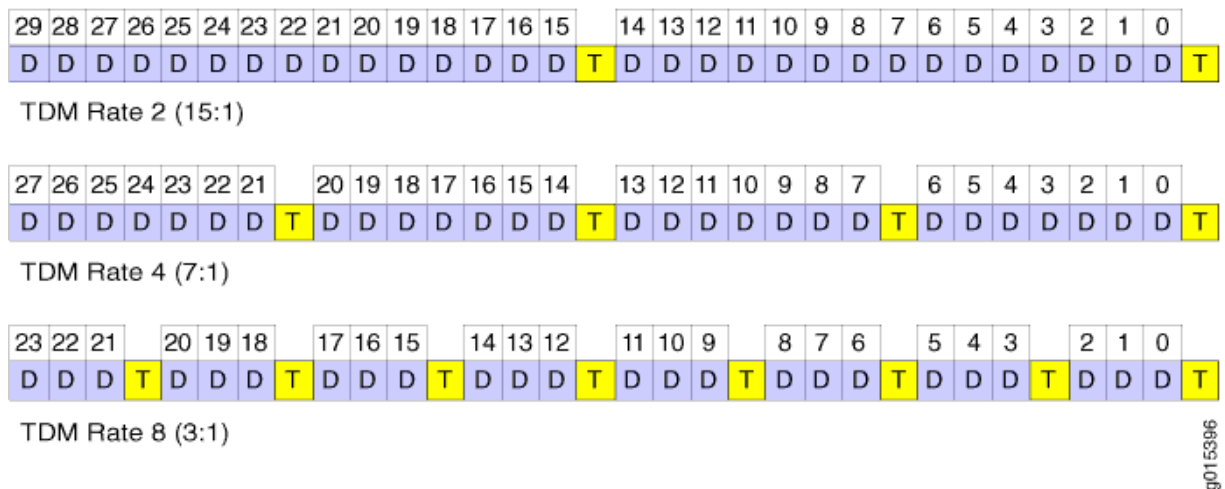

## How the CTP Implementation of TDM/TDC Works

To use this feature, you configure two bundles on each CTP device:

- A high-speed bundle that carries all traffic by interleaving multiple data sources into a single stream.
- A low-speed bundle that routes clock and data signals.

The high-speed bundle oversamples the incoming clock (TT) and data (SD) from the low-speed bundle. At the remote end of the network, the embedded circuit data is recovered and exits the node on the



low-speed bundle as RT and RD outputs. The direct interleaving of two bundles' data allows TDC to be maintained between the two bundles with an accuracy of one bit time at the bundle's data rate.

The low-speed bundle receives network-bound clock and data signals from the user equipment and inserts it into the bundle. It also transmits interface-bound clock and data from the bundle to the user equipment.

**Figure 9: TDC Application Over TDM Using 16-in-32 TDM Rate**

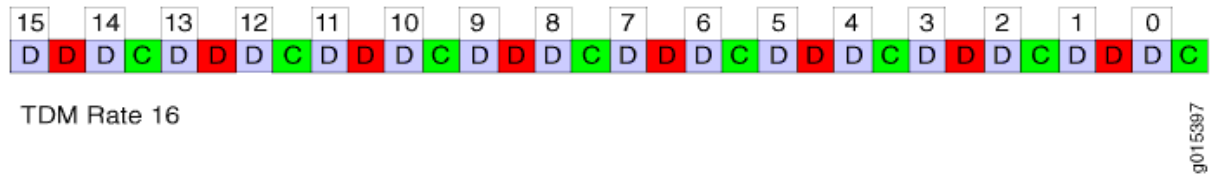

In Figure 4:

- The blue D bits synchronously carry the higher-speed circuit.
- The red D bits asynchronously oversample and transport the lower-speed circuit data.
- The green C bits asynchronously oversample and transport the lower-speed circuit clock.

**TDM Rates**

At the maximum TDM rate of 16, the CTP device can transport four low-speed bits for every eight high-speed bits as shown in [Figure 10 on page 33](#).

**Figure 10: High-Speed and Low-Speed Ratio at the Maximum TDM Rate of 16**

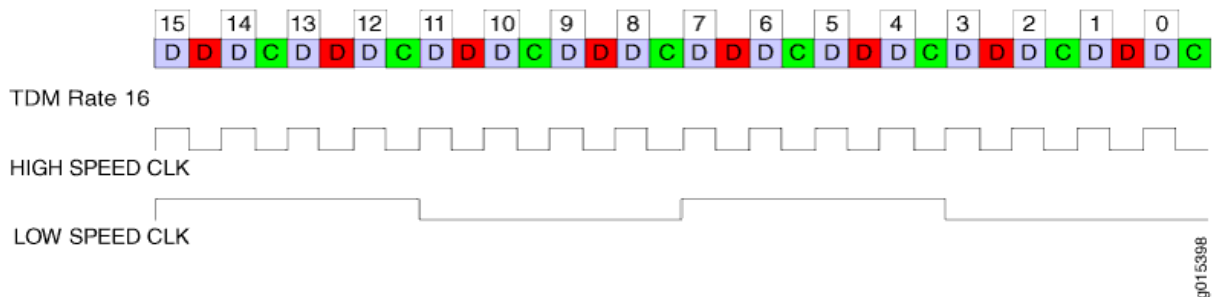

If the ratio of circuit speeds is higher than 8:1, then you can use lower TDM rates, which allocates fewer bits for the TDM function and therefore uses less network bandwidth. [Figure 11 on page 34](#) shows other supported TDM rates as applied to TDC.

Figure 11: TDM Rates as Applied to TDC

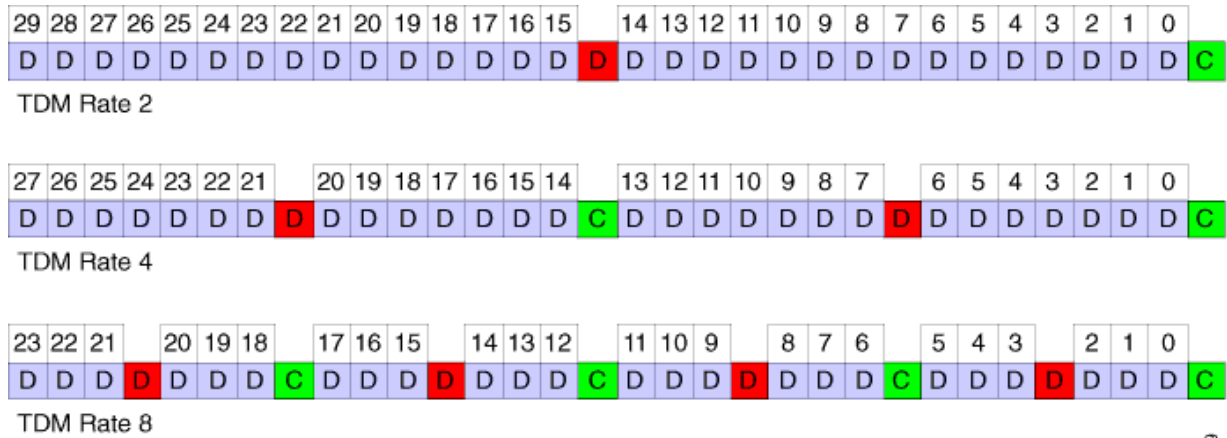

g015399

### TDM High-Speed and Low-Speed Ports

To use the TDM/TDC feature, you configure a high-speed bundle and a low-speed bundle as follows:

- The high-speed bundle is configured on an even-numbered port, and it is configured for TDM encoding because it interleaves multiple data sources into a single stream.
- The low-speed bundle is configured on an odd-numbered port that is one port number higher (N+1) than the high-speed port. It is configured for TDM/TDC clocking because it routes clock and data signals.

Figure 12 on page 35 shows a high-speed port and low-speed port.

Figure 12: TDM/TDC High-Speed and Low-Speed Ports

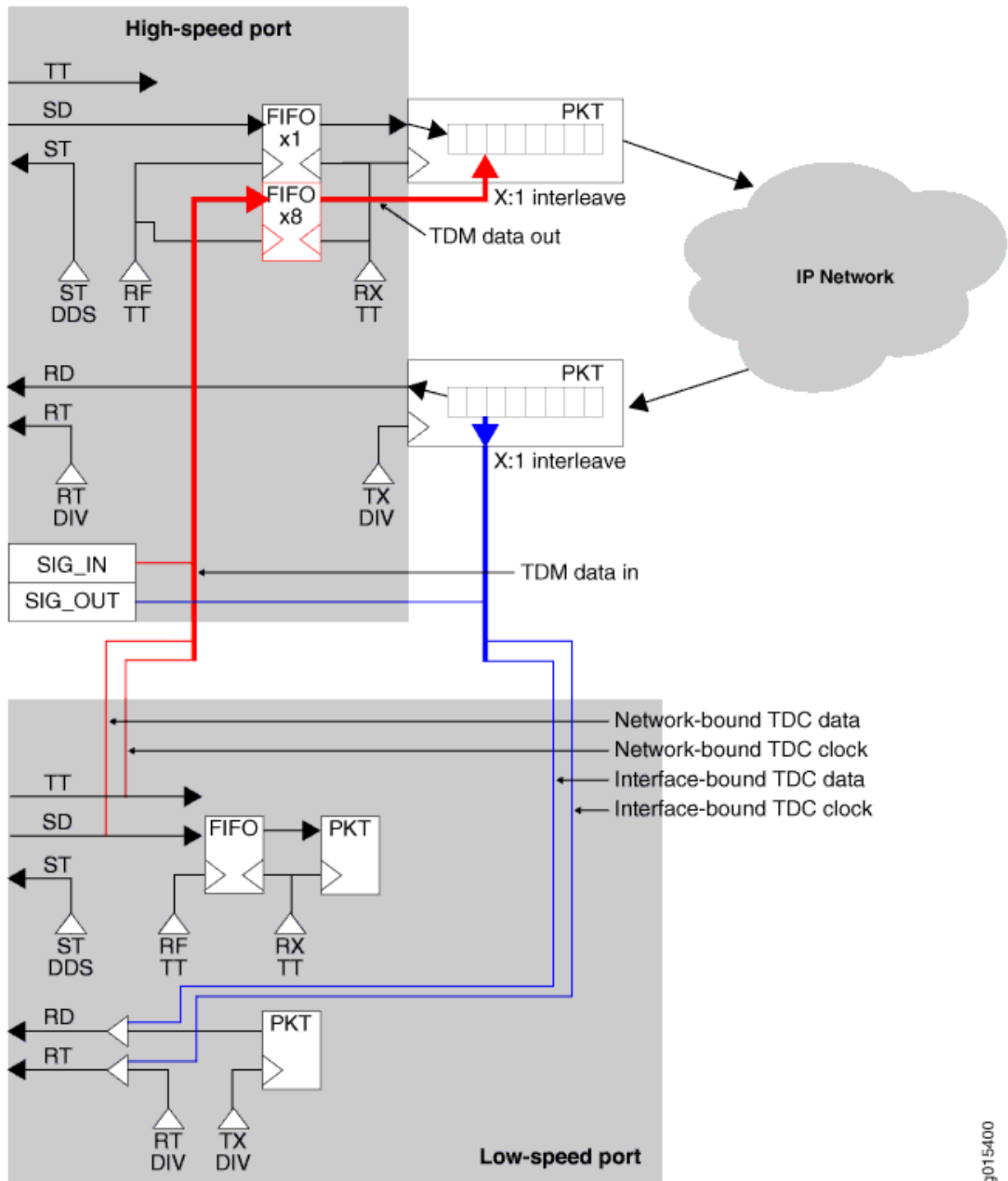

As shown in the figure:

- The red path shows the network-bound path for the low-speed TDC data and clock. The low-speed port receives the clock and data signals from the user equipment, and transmits it to the transmit data *jitter* FIFO on the high-speed port. Once out of the FIFO, the CTP device interleaves the TDC data streams into a single packet flow for the TDM/TDC bundle.
- The blue path shows the interface-bound path for the TDC data and clock. The low-speed port transmits the interface-bound clock and data from the TDM/TDC bundle to the user equipment.

## RELATED DOCUMENTATION

[Configuring Bundle Pairs for TDM/TDC Operation \(CTP Menu\) | 72](#)

[Configuring Bundle Pairs for TDM/TDC Operation \(CTPView\) | 171](#)

# Ethernet Media Configuration Overview

## IN THIS CHAPTER

- [Ethernet Media Configuration Overview | 37](#)

## Ethernet Media Configuration Overview

### IN THIS SECTION

- [Support for Full-Duplex Mode Only on NIC Ports Connected to CTP Devices | 38](#)

You can configure the CTP Ethernet media to autonegotiate and set the speed to either 100 or 10 Mbps. By default, autonegotiation is enabled and the speed is to 1000 Mbps. If you choose to disable autonegotiation, the system prompts you to configure the desired speed.

The Ethernet configurations on CTP must match the configuration of the connected router or switch. Mismatched configurations, such as setting the CTP system to autonegotiate and the router to full duplex, will result in a misconfiguration and dropped packets. You must disable Cisco Discovery Protocol on the Fast Ethernet port connected to the CTP system.

[Table 6 on page 37](#) lists the valid Ethernet media configuration settings that CTP Series supports.

**Table 6: Valid Ethernet Media Configuration Settings for CTP**

Speed	Autoneg Status	Mode (Duplex)	MTU (up to 1500)
1000	ON	Full	any
100	OFF	Full	any

**Table 6: Valid Ethernet Media Configuration Settings for CTP (Continued)**

Speed	Autoneg Status	Mode (Duplex)	MTU (up to 1500)
10	OFF	Full	any

**NOTE:** The CTP system supports only full duplex mode.

### Support for Full-Duplex Mode Only on NIC Ports Connected to CTP Devices

If the autonegotiation setting of the CTP Ethernet media and the far-end switch or router do not match, it is possible for the CTP Ethernet ports to be in a half-duplex state, although the duplex setting is not configurable and always assumed to be full-duplex on the CTP device. Starting with CTPOS and CTPView Release 7.2, only full-duplex mode is supported on the network interface card (NIC) ports of the far-end switch or router connected to the CTP devices and if you do not configure full-duplex on NIC ports during the autonegotiation process, then the interfaces are considered to be down and a log message is recorded in both the `/var/log/messages` directory and the syslog file stating that the interface is down due to a non-full duplex condition. You are prompted to verify the cable connection, speed, and duplex settings because the NIC link might be down.

The default speed for autonegotiation is 100 Mbps. To configure Ethernet interfaces on a CTP device using the CTP Menu, from the Main Menu, select **5) Node Operations**. Display the current Ethernet configuration by selecting **12) Config ethernet media**. You can configure autonegotiation to be enabled, which sets the speed as 1000 Mbps. Mismatched configurations, such as setting the CTP system to autonegotiate and the router to full duplex, may result in a misconfiguration and dropped packets. You must disable Cisco Discovery Protocol on the Fast Ethernet port connected to the CTP system.

#### RELATED DOCUMENTATION

[Configuring Ethernet Media \(CTP Menu\) | 113](#)

[Displaying Ethernet Media Information \(CTP Menu\) | 115](#)

# 2

PART

## Configuration

---

[Configuring CTP Bundles \(CTP Menu\) | 40](#)

[Configuring CTP Bundles \(CTPView\) | 139](#)

---

# Configuring CTP Bundles (CTP Menu)

## IN THIS CHAPTER

- Adding a Bundle (CTP Menu) | 41
- Configuring IP Parameters for CTP Bundles (CTP Menu) | 41
- Configuring Circuit Startup Parameters for CTP Bundles (CTP Menu) | 44
- Configuring the Direction of the Circuit (CTP Menu) | 46
- Configuring Virtual IP Parameters for CTP Bundles (CTP Menu) | 46
- Configuring the Missing Packet Fill Pattern for CTP Bundles (CTP Menu) | 47
- Configuring Signaling for CTP Bundles (CTP Menu) | 48
- Configuring Multiservice Port Parameters for CTP Bundles (CTPView) | 55
- Configuring Serial Port Parameters for CTP Bundles (CTP Menu) | 65
- Configuring Transparent Encoding for CTP Bundles (CTP Menu) | 69
- Configuring Bundle Pairs for TDM/TDC Operation (CTP Menu) | 72
- Configuring T1 and E1 Port Parameters for CTP Bundles (CTP Menu) | 75
- Configuring Multiservice Port Parameters for CTP Bundles (CTP Menu) | 80
- Configuring 4WTO Port Parameters for CTP Bundles (CTP Menu) | 89
- Configuring IRIG-B Port Parameters for CTP Bundles (CTP Menu) | 94
- Configuring Advanced Port Options for CTP Bundles (CTP Menu) | 97
- Selecting the Type of Clocking on Serial Ports for CTP Bundles (CTP Menu) | 99
- Configuring Custom Clocking for CTP Bundles (CTP Menu) | 103
- Configuring Adaptive Clocking for CTP Bundles (CTP Menu) | 110
- Configuring Ethernet Media (CTP Menu) | 113
- Displaying Ethernet Media Information (CTP Menu) | 115
- Configuring PBS and Bridge Ports (CTP Menu) | 115
- Configuring Port Mirroring for CTP Bundles (CTP Menu) | 119
- Configuring NetRef for Adaptive Bundle Operation | 124
- Configuring NetRef for Primary or Backup Operation | 125
- Configuring NetRef Multiple Primary Nodes (CTP Menu) | 126



- [Configuring NetRef Settings \(CTPView\) | 132](#)
- [Configuring LOS Detection on CTP and SAToP Bundles \(CTP Menu\) | 134](#)
- [Configuring Cryptographic Resynchronization \(Crypto Resync\) | 135](#)
- [Gathering Node Debugging Information \(CTP Menu\) | 138](#)

## Adding a Bundle (CTP Menu)

To add a bundle using the CTP Menu:

1. From the CTP Main Menu, select **1) Bundle Operations**.
2. Select the type of bundle that you want to configure.

Before you create a VComp bundle, you must ensure that the CTP system has a VComp card installed. The CTP system displays a warning message if no VComp card is installed. If you create a VComp bundle on a CTP system that does not have a VComp card installed and try to activate it, the CTP system displays the following warning message:

```
There is not enough system DSP resource for the bundle.
```

The bundle remains disabled until you install a VComp card and activate the bundle again. If you remove the VComp card from a CTP system that has an active VComp bundle, the Run state of the VComp bundle changes to MisCfg.

3. Enter **add** to add a new bundle.
4. Select the port you want to attach the bundle to.

## Configuring IP Parameters for CTP Bundles (CTP Menu)

The CTP software uses the IP parameters to create IP packets.

Before you begin:

- Disable the bundle before you modify the bundle options.

To configure IP parameters for CTP bundles using the CTP Menu:

1. From the CTP Main Menu, select **1) Bundle Operations**.
2. Select **1) CTP**.

3. Select a bundle from the list.

If you select an active bundle, you are prompted to disable the bundle before configuring it.

4. Select **2) Config** to configure the bundle.

5. Configure options 1 through 9 as described in [Table 7 on page 42](#).

**Table 7: CTP Bundle IP Parameter Settings in the CTP Menu**

Field	Function	Your Action
Remote Address	Specifies the name and IP address of the remote CTP device.	Enter the address of the remote CTP device.
Remote Circuit ID	Specifies the bundle to connect to on the remote CTP device.	Enter a number from 0 through 249.
Local Circuit ID	Specifies the bundle on the local CTP device.	Enter a number from 0 through 249.
Packet Size	Specifies the size of IP packets that are created from data received at the serial port.  The CTP device makes sure that the combination of packet size and data rate does not result in a packet rate that exceeds 1200 packets per second.	For CTP150 devices, enter a number from 8 through 1456.  For CTP2000 devices, enter a number from 4 through 1456.
Min Buffer	Specifies the minimum average buffer size. Use a value that is greater than the expected jitter and less than the Pkt Buffer Set parameter.  The minimum buffer ensures that the buffer does not become too small because of timing variances between the local and remote serial interfaces.  The entire buffer is available for accommodating and smoothing packet delay jitter, regardless of the minimum buffer setting.	Enter a number from 0.001 through 9999.000 milliseconds.
Pkt Buffer Set	Specifies the buffer size when the circuit enters a running state. This value must be large enough to accommodate the anticipated packet delay, and it must be set to a value greater than the minimum buffer size and lower than the maximum buffer size.	Enter a number from 0.001 through 9999.000 milliseconds.

Table 7: CTP Bundle IP Parameter Settings in the CTP Menu *(Continued)*

Field	Function	Your Action
Max Buffer	<p>Specifies the maximum buffer size. The maximum buffer ensures that the buffer does not become too large due to timing variances between the local and remote serial interfaces. If the buffer size exceeds the maximum buffer size, the buffer is recentered to the Pkt Buffer Set value.</p> <p>Periodic buffer recenters are not expected. If you notice recenters, we recommend that you verify the reference to the CTP (if used) or that you configure one port with adaptive clocking.</p>	Enter a number from 0.001 through 9999.000 milliseconds.
Service Type	<p>Specifies the ToS byte to be used in the IP headers of packets sent from the CTP device to the IP network.</p> <p>For a mapping of ToS byte values to DSCP classes and settings, see <a href="#">Providing QoS for CTP Bundles by Using Service Type Overview</a>.</p> <p>You do not need to set the ToS value to the same value on local and remote bundles.</p>	Enter a number from 0 through 255.
Time to Live	<p>Specifies the maximum number of router hops that a packet can traverse. The CTP device sets the TTL value in IP packets that it sends to the IP network. The IP network does not alter or optimize the packet routing based on the TTL setting. You do not need to set the same TTL value on local and remote ports.</p>	Enter a number from 0 through 255.
Bundle Description	<p>Specifies identifying information about the bundle.</p> <p>You can use the bundle description as the search criteria when you search for bundles from the network monitoring page.</p>	Type a description for the bundle.

## RELATED DOCUMENTATION

[Providing QoS for CTP Bundles by Using Service Type Overview](#)

## Configuring Circuit Startup Parameters for CTP Bundles (CTP Menu)

This topic describes how to configure advanced options that are related to circuit startup. Set these parameters to the same values on the local and remote CTP devices.

Before you begin:

- Disable the bundle before you modify the bundle options.

To configure circuit startup parameters using the CTP Menu:

1. From the CTP Main Menu, select **1) Bundle Operations**.
2. Select **1) CTP**.
3. Select a bundle from the list.  
If you select an active bundle, you are prompted to disable the bundle before configuring it.
4. Select **2) Config**.
5. Select **10) Advanced Options**.
6. Configure options 4, 5, 6, 7, 8, and 15 as described in [Table 8 on page 44](#).

**Table 8: CTP Bundle Advanced Options Parameter Settings for Circuit Startup in the CTP Menu**

Field	Function	Your Action
Consecutive pkts loss to starve	Specifies how many consecutive circuit packets the IP network must drop before the CTP device restarts the circuit.  We recommend that you set the parameter to a larger value when the IP network uses packet-encrypting devices. These devices cause momentary interruption in packet flows when encryption keys are updated.	Enter a number from 1 through 64.
In sequence pkts after starve	Specifies the number of in-sequence packets the CTP device must receive after a starvation before the circuit transitions from in-sync to running.	Enter a number from 1 through 64.
OAM Chan Rate (pkt/sec)	Specifies the number of OAM packets per second that the circuit sends to the remote CTP device.	Enter a number from 1 through 255.

**Table 8: CTP Bundle Advanced Options Parameter Settings for Circuit Startup in the CTP Menu**  
(Continued)

Field	Function	Your Action
OAM pkts for Sync	Specifies the number of OAM packets that the circuit must receive before the state moves from no synchronization to in synchronization.	Enter a number from 1 through 255.
OAM pkts for Sync Loss	Specifies the number of received OAM packets that the CTP device misses before the state of the circuit moves from in synchronization to no synchronization.	Enter a number from 1 through 255.
OAM-free CTP bundle	Specifies whether to use the full duplex OAM communication to bring CTP bundle to the running state.	<p>Select one:</p> <ul style="list-style-type: none"> <li>• No—CTP bundle uses the full duplex OAM communication to bring CTP bundle to the running state. When a bundle is activated, the CTP device sends OAM packets to the remote circuit until the required number of packets is received. The circuit then changes its state to 'running' and begins sending data packets.</li> <li>• Yes—CTP bundle does not use the full duplex OAM communication to bring CTP bundle to the running state. When a bundle is activated, the circuit directly changes its state to 'running' and begins sending data packets. When set to 'Yes', other bundle OAM parameter values are ignored.</li> </ul>

## RELATED DOCUMENTATION

[Circuit Startup Process Overview](#) | 13

## Configuring the Direction of the Circuit (CTP Menu)

This topic describes how to configure the direction of the circuit.

Before you begin:

- Disable the bundle before you modify the bundle options.

To configure the direction of circuits created with the CTP bundle using the CTP Menu:

1. From the CTP Main Menu, select **1) Bundle Operations**.
2. Select **1) CTP**.
3. Select a bundle from the list.

If you select an active bundle, you are prompted to disable the bundle before configuring it.

4. Select **2) Config**.
5. Select **10) Advanced Options**.
6. Configure option 10 as described in [Table 9 on page 46](#).

**Table 9: CTP Bundle Circuit Direction Setting in the CTP Menu**

Field	Function	Your Action
Unidirectional circuit	Specifies whether the circuit is unidirectional or bidirectional. If unidirectional, specify the direction of the circuit—source or destination.	Select one: <ul style="list-style-type: none"> <li>• Bidirectional circuit—Circuit is bidirectional.</li> <li>• Unidirectional circuit source—Circuit is unidirectional, and this end of the circuit is the source.</li> <li>• Unidirectional circuit destination—Circuit is unidirectional, and this end of the circuit is the destination.</li> </ul>

## Configuring Virtual IP Parameters for CTP Bundles (CTP Menu)

The virtual IP parameters allow you to use a separate IP address for each bundle and to use an address that is different from the IP address for the CTP device. If you configure the IP address on the:

- Same subnet as the CTP IP address, you do not need a static route on the router.
- Different subnet as the CTP IP address, you need a static route on the router.

Before you begin:

- Create a list of the virtual IP addresses that will be associated with the CTP device. To do so, From the CTP Main Menu, select **Node Operations > Configure network settings > Virtual IP addresses** and follow the onscreen instructions. You can create up to 100 virtual IP addresses (IPv4 only).

When you submit your new configuration, the CTP device reboots.

- Disable the bundle before you modify the bundle options.

To configure virtual IP parameters for CTP bundles using the CTP Menu:

1. From the CTP Main Menu, select **1) Bundle Operations**.

2. Select **1) CTP**.

3. Select a bundle from the list.

If you select an active bundle, you are prompted to disable the bundle before configuring it.

4. Select **2) Config**.

5. Select **10) Advanced Options**.

6. Configure options 1 and 2 as described in [Table 10 on page 47](#).

**Table 10: CTP Bundle Virtual IP Parameter Settings in the CTP Menu**

Field	Function	Your Action
Use virtual ip for port	Specifies whether or not the bundle uses an address that is different from the IP address of the CTP device.  The virtual IP address is used in the IP packet's Origination Address field, and is used for the circuit's data and OAM flow.	Select one: <ul style="list-style-type: none"> <li>• n (no)—Circuits created by this bundle use the IP address of the CTP device.</li> <li>• y (yes)—Circuits created by this bundle use an address that is different from the CTP device.</li> </ul>
Virtual ip for port	Specifies the virtual IP address for circuits created by this bundle.	Select an IP address from the list displayed.  At the remote end of the bundle, specify this IP address as the Remote Address of the bundle.

## Configuring the Missing Packet Fill Pattern for CTP Bundles (CTP Menu)

This topic describes how to specify the fill pattern that the CTP device inserts when IP packets are dropped.

Before you begin:

- Disable the bundle before you modify the bundle options.

To configure the missing packet fill pattern for CTP bundles using the CTP Menu:

1. From the CTP Main Menu, select **1) Bundle Operations**.
2. Select **1) CTP**.
3. Select a bundle from the list.

If you select an active bundle, you are prompted to disable the bundle before configuring it.

4. Select **2) Config**.
5. Select **10) Advanced Options**.
6. Configure option **3) Missing pkt fill pattern** as described in [Table 11 on page 48](#).

**Table 11: CTP Bundle Missing Packet Fill Pattern Parameter Setting in the CTP Menu**

Field	Function	Your Action
Missing pkt fill pattern	<p>Specifies the data that the CTP device inserts into the circuit bit stream when an IP packet is dropped. The number of bits inserted is equal to the number of bits in the missed packet.</p> <p>When the bundle is down, the port sends the value of the least significant bit (LSB) of the missing fill pattern.</p> <p>This data insertion method prevents a loss of bit count integrity to attached circuit devices and encryptors.</p>	<p>Enter two hexadecimal digits. You must enter a value other than ff. This field does not require the 0x characters.</p>

## Configuring Signaling for CTP Bundles (CTP Menu)

You can set input and output signals for the CTP device. Your settings should be based on the settings of the user equipment.

- Output signals—You can set output signals to a fixed value, or you can set them to inband so that the output signal state is based on the state of the input signal at the user equipment. Output signals that you can set vary depending on whether the bundle is configured as the DTE or the DCE:
  - DTE output signals:
    - DTR (data set ready)
    - RTS (request to send)



- LL (local loopback)
- RL (remote loopback)
- DCE output signals:
  - DSR (data set ready)
  - CTS (clear to send)
  - DCD (data carrier detect)
  - TM (test mode)
- Input signals—You can set the input signals to either unused (ignored) or used to create a demand circuit. When configured for demand, packets created from the circuit are transferred across the IP network only when the signal lead is in the specified state for the circuit to be **Demand Call – Active**. When two or more leads are configured for demand, all configured leads must be in the **Demand Call – Active** state for the circuit to transfer packets across the IP network.

Input signals that you can set vary depending on whether the bundle is configured as the DTE or the DCE:

- DTE—Input signals are TM, CTS, DSR, DCD.
- DCE—Input signals are RL, RTS, DTR, LL.

The input state of each signal lead is encoded once in every transmitted IP packet. Thus the granularity of the transitions (frequency or changes) that can be transferred across the network is equal to the packet rate of the circuit.

Before you begin:

- Disable the bundle before you modify the bundle options.

To configure signaling for CTP bundles using the CTP Menu:

1. From the CTP Main Menu, select **1) Bundle Operations**.
2. Select **1) CTP**.
3. Select a bundle from the list.
 

If you select an active bundle, you are prompted to disable the bundle before configuring it.
4. Select **2) Config**.
5. Select **10) Advanced Options**.
6. Select **11) Signaling Config**.
7. Configure the options as described in [Table 12 on page 50](#).

Table 12: CTP Bundle Signaling Parameter Settings in the CTP Menu

Field	Function	Your Action
DSR (output)	Specifies the DSR output signal from the port interface (when configured as DCE).	Select one: <ul style="list-style-type: none"> <li>• 0) Fixed</li> </ul>
DTR (output)	Specifies the DTR output signal from the port interface (when configured as DTE).	<ul style="list-style-type: none"> <li>• 1) In-Band</li> </ul> If you chose Fixed, select: <ul style="list-style-type: none"> <li>• 0=Space=Low=On—Signal is turned on.</li> <li>• 1=Mark=High=Off—Signal is turned off.</li> </ul> If you chose In-Band, select a remote signal source: <ul style="list-style-type: none"> <li>• 0) RL from rem DCE, TM from rem DTE— Output signal is based on the state of the RL input signal from remote port interface (when configured as DCE), or the TM signal from remote port interface (when configured as DTE).</li> <li>• 1) RTS from rem DCE, CTS from rem DTE— Output signal is based on the state of the RTS input signal from the remote port interface (when configured as DCE), or the CTS signal from the remote port interface (when configured as DTE).</li> <li>• 2) DTR from rem DCE, DSR from rem DTE— Output signal is based on the state of the DTR input signal from the remote port interface (when configured as DCE), or the DSR signal from the remote port interface (when configured as DTE).</li> <li>• 3) LL from rem DCE, DCD from rem DTE— Output signal is based on the state of the LL input signal from the remote port interface (when configured as DCE), or the DCD signal from the remote port interface (when configured as DTE).</li> </ul>

Table 12: CTP Bundle Signaling Parameter Settings in the CTP Menu *(Continued)*

Field	Function	Your Action
CTS (output)	Specifies the CTS output signal from the port interface (when configured as DCE).	Select one: <ul style="list-style-type: none"> <li>• 0) Fixed</li> </ul>
RTS (output)	Specifies the RTS output signal from the port interface (when configured as DTE).	<ul style="list-style-type: none"> <li>• 1) In-Band</li> </ul> If you chose Fixed, select: <ul style="list-style-type: none"> <li>• 0=Space=Low=On—Signal is turned on.</li> <li>• 1=Mark=High=Off—Signal is turned off.</li> </ul> If you chose In-Band, select a remote signal source: <ul style="list-style-type: none"> <li>• 0) RL from rem DCE, TM from rem DTE— Output signal is based on the state of the RL input signal from the remote port interface (when configured as DCE), or the TM signal from the remote port interface (when configured as DTE).</li> <li>• 1) RTS from rem DCE, CTS from rem DTE— Output signal is based on the state of the RTS input signal from the remote port interface (when configured as DCE), or the CTS signal from the remote port interface (when configured as DTE).</li> <li>• 2) DTR from rem DCE, DSR from rem DTE— Output signal is based on the state of the DTR input signal from the remote port interface (when configured as DCE), or the DSR signal from the remote port interface (when configured as DTE).</li> <li>• 3) LL from rem DCE, DCD from rem DTE— Output signal is based on the state of the LL input signal from the remote port interface (when configured as DCE), or the DCD signal from the remote port interface (when configured as DTE).</li> </ul>

Table 12: CTP Bundle Signaling Parameter Settings in the CTP Menu *(Continued)*

Field	Function	Your Action
DCD (output)	Specifies the DCD output signal from the port interface (when configured as DCE).	Select one: <ul style="list-style-type: none"> <li>• 0) Fixed</li> </ul>
LL (output)	Specifies the LL output signal from the port interface (when configured as DTE).	<ul style="list-style-type: none"> <li>• 1) In-Band</li> </ul> If you chose Fixed, select: <ul style="list-style-type: none"> <li>• 0=Space=Low=On—Signal is turned on.</li> <li>• 1=Mark=High=Off—Signal is turned off.</li> </ul> If you chose In-Band, select a remote signal source: <ul style="list-style-type: none"> <li>• 0) RL from rem DCE, TM from rem DTE— Output signal is based on the state of the RL input signal from the remote port interface (when configured as DCE), or the TM signal from the remote port interface (when configured as DTE).</li> <li>• 1) RTS from rem DCE, CTS from rem DTE— Output signal is based on the state of the RTS input signal from the remote port interface (when configured as DCE), or the CTS signal from the remote port interface (when configured as DTE).</li> <li>• 2) DTR from rem DCE, DSR from rem DTE— Output signal is based on the state of the DTR input signal from the remote port interface (when configured as DCE), or the DSR signal from the remote port interface (when configured as DTE).</li> <li>• 3) LL from rem DCE, DCD from rem DTE— Output signal is based on the state of the LL input signal from the remote port interface (when configured as DCE), or the DCD signal from the remote port interface (when configured as DTE).</li> </ul>

Table 12: CTP Bundle Signaling Parameter Settings in the CTP Menu (*Continued*)

Field	Function	Your Action
TM (output)	Specifies the TM output signal from the port interface (when configured as DCE).	Select one: <ul style="list-style-type: none"> <li>• 0) Fixed</li> </ul>
RL (output)	Specifies the RL output signal from the port interface (when configured as DTE).	<ul style="list-style-type: none"> <li>• 1) In-Band</li> </ul> If you chose Fixed, select: <ul style="list-style-type: none"> <li>• 0=Space=Low=On—Signal is turned on.</li> <li>• 1=Mark=High=Off—Signal is turned off.</li> </ul> If you chose In-Band, select a remote signal source: <ul style="list-style-type: none"> <li>• 0) RL from rem DCE, TM from rem DTE— Output signal is based on the state of the RL input signal from the remote port interface (when configured as DCE), or the TM signal from the remote port interface (when configured as DTE).</li> <li>• 1) RTS from rem DCE, CTS from rem DTE— Output signal is based on the state of the RTS input signal from the remote port interface (when configured as DCE), or the CTS signal from the remote port interface (when configured as DTE).</li> <li>• 2) DTR from rem DCE, DSR from rem DTE— Output signal is based on the state of the DTR input signal from the remote port interface (when configured as DCE), or the DSR signal from the remote port interface (when configured as DTE).</li> <li>• 3) LL from rem DCE, DCD from rem DTE— Output signal is based on the state of the LL input signal from the remote port interface (when configured as DCE), or the DCD signal from the remote port interface (when configured as DTE).</li> </ul>

Table 12: CTP Bundle Signaling Parameter Settings in the CTP Menu (*Continued*)

Field	Function	Your Action
RL (input)	Specifies the RL input signal from the port interface (when configured as DCE).	Select one: <ul style="list-style-type: none"> <li>• 0) Unused—Input signals are ignored.</li> </ul>
TM (input)	Specifies the TM input signal from the port interface (when configured as DTE).	<ul style="list-style-type: none"> <li>• 1) Demand call.</li> </ul> <p>If you chose Demand call, select an input signal value:</p> <ul style="list-style-type: none"> <li>• 0=Space=Low=On—Signal is turned on.</li> <li>• 1=Mark=High=Off—Signal is turned off.</li> </ul>
RTS (input)	Specifies the RTS input signal from the port interface (when configured as DCE).	Select one: <ul style="list-style-type: none"> <li>• 0) Unused—Input signals are ignored.</li> </ul>
CTS (input)	Specifies the CTS input signal from the port interface (when configured as DTE).	<ul style="list-style-type: none"> <li>• 1) Demand call.</li> </ul> <p>If you chose Demand call, select an input signal value:</p> <ul style="list-style-type: none"> <li>• 0=Space=Low=On—Signal is turned on.</li> <li>• 1=Mark=High=Off—Signal is turned off.</li> </ul>
DTR (input)	Specifies the DTR input signal from the port interface (when configured as DCE).	Select one: <ul style="list-style-type: none"> <li>• 0) Unused—Input signals are ignored.</li> </ul>
DSR (input)	Specifies the DSR input signal from the port interface (when configured as DTE).	<ul style="list-style-type: none"> <li>• 1) Demand call.</li> </ul> <p>If you chose Demand call, select an input signal value:</p> <ul style="list-style-type: none"> <li>• 0=Space=Low=On—Signal is turned on.</li> <li>• 1=Mark=High=Off—Signal is turned off.</li> </ul>
LL (input)	Specifies the LL input signal from the port interface (when configured as DCE).	Select one: <ul style="list-style-type: none"> <li>• 0) Unused—Input signals are ignored.</li> </ul>

Table 12: CTP Bundle Signaling Parameter Settings in the CTP Menu *(Continued)*

Field	Function	Your Action
DCD (input)	Specifies the DCD input signal from the port interface (when configured as DTE).	<ul style="list-style-type: none"> <li>• 1) Demand call.</li> </ul> <p>If you chose Demand call, select an input signal value:</p> <ul style="list-style-type: none"> <li>• 0=Space=Low=On—Signal is turned on.</li> <li>• 1=Mark=High=Off—Signal is turned off.</li> </ul>
Output delay (pkts)	Specifies the output signaling delay in packets.	Enter a number from 0 through 3.

## Configuring Multiservice Port Parameters for CTP Bundles (CTPView)

### IN THIS SECTION

- [Configuring Multiservice Audio Mode Port Parameters for CTP Bundles \(CTPView\) | 55](#)
- [Configuring Multiservice IRIG-B Mode Port Parameters for CTP Bundles \(CTPView\) | 58](#)
- [Configuring Multiservice TDC Mode Parameters for CTP Bundles \(CTPView\) | 60](#)
- [Configuring Multiservice 4WTO Mode Port Parameters for CTP Bundles \(CTPView\) | 62](#)

### Configuring Multiservice Audio Mode Port Parameters for CTP Bundles (CTPView)

Before you begin:

- Log in to the CTPView software at least at the Net\_Admin level.
- Connect the CTPView server to the CTP device for which you want to configure bundles.

To configure Multiservice audio mode port parameters using CTPView:

1. In the side pane, select **Bundle > Configuration**.
2. Run your mouse over the **Display and Select an Existing Bundle** bar.

3. In the table of bundles, select the bundle that you want to modify.
4. Under **Bundle Options**, configure the parameters as described in [Table 13 on page 56](#) and click **Click to Submit Bundle AND Port Changes**.

**Table 13: CTP Bundle Multiservice Audio Port Parameter Settings in CTPView**

Field	Function	Your Action
Port Description	Specifies a description for the port.	Enter a description of up to 64 alphanumeric characters. Do not use the following characters:  ( ; ' " ) ]
I/F Type	Specifies the daughter card as the interface type.	Select DCARD.
Multi-Service Mode	Specifies that the bundle will run in audio mode.	Select Audio.
Audio Mode	Specifies whether this end of the circuit provides clocking or uses adaptive clocking.  If the CTP devices at both ends of the circuit are synchronized, you can configure both ends as Primary.	Select one: <ul style="list-style-type: none"> <li>• Primary—This end of the circuit provides clocking.</li> <li>• Member—This end of the circuit uses adaptive clocking.</li> </ul>
Audio Channel	Specifies the channel or channels to enable.	Select one: <ul style="list-style-type: none"> <li>• Channel 0—Enables only channel 0.</li> <li>• Dual Channel—Enables both channel 0 and channel 1.</li> </ul>



Table 13: CTP Bundle Multiservice Audio Port Parameter Settings in CTPView (Continued)

Field	Function	Your Action
Audio Sample Rate [ KHz ]	<p>Specifies the sample rate for audio circuits in kilohertz. The sample rate determines the audio quality and the network bandwidth needed. Higher sample rates create an IP data flow that requires higher bandwidth.</p> <p>8 KHz corresponds to standard toll quality voice.</p> <p>48 KHz corresponds to CD quality audio.</p>	<p>Select one:</p> <ul style="list-style-type: none"> <li>• 8</li> <li>• 12</li> <li>• 16</li> <li>• 24</li> <li>• 32</li> <li>• 48</li> </ul>
Audio $\mu$ -law Encoding	<p>Enables or disables <math>\mu</math>-law encoding. Standard audio code samples are 16 bits. If you enable <math>\mu</math>-law encoding, the 16-bit samples are converted to 8 bits, consuming half of the bandwidth without significant audio degradation.</p>	<p>Select one:</p> <ul style="list-style-type: none"> <li>• DISABLED (16 bit samples)—Generates 16-bit audio samples.</li> <li>• ENABLED (8 bit samples)—Generates 8-bit audio samples.</li> </ul>
Audio Squelch	<p>Enables or disables the active squelch function on the circuit.</p> <p>If enabled, specifies whether the squelch is active or inactive.</p> <p>The squelch function gates local audio output when DSR-A (channel 0) or RTS-A (channel 1) inputs are active or inactive.</p>	<p>Select one:</p> <ul style="list-style-type: none"> <li>• DISABLED—Disables the active squelch function on the circuit (audio output is always enabled).</li> <li>• ENABLED/ACTIVE—Squelch input is grounded and analog output is disabled.</li> <li>• ENABLED/INACTIVE—No signal is applied to the squelch input. Input is open and analog output is possible.</li> </ul>

**Table 13: CTP Bundle Multiservice Audio Port Parameter Settings in CTPView (Continued)**

Field	Function	Your Action
Audio Channel 0 Output Level	<p>Specifies the output level for channel 0.</p> <p>Note the following information about the values:</p> <ul style="list-style-type: none"> <li>• 0—There is no output.</li> <li>• 128—Unity gain, which means there is no attenuation or gain.</li> <li>• 255—Gain is 2:1.</li> </ul>	Enter a number from 0 through 255.
Audio Channel 1 Output Level	<p>Specifies the output level for channel 1.</p> <p>Note the following information about the values:</p> <ul style="list-style-type: none"> <li>• 0—There is no output.</li> <li>• 128—Unity gain, which means there is no attenuation or gain.</li> <li>• 255—Gain is 2:1.</li> </ul>	Enter a number from 0 through 255.

## SEE ALSO

*Serial Multiservice Interface Module Overview*

## Configuring Multiservice IRIG-B Mode Port Parameters for CTP Bundles (CTPView)

Before you begin:

- Log in to the CTPView software at least at the Net\_Admin level.
- Connect the CTPView server to the CTP device for which you want to configure bundles.

To configure Multiservice IRIG-B mode port parameters using CTPView:

1. In the side pane, select **Bundle > Configuration**.
2. Run your mouse over the **Display and Select an Existing Bundle** bar.
3. In the table of bundles, select the bundle that you want to modify.

4. Under **Bundle Options**, configure the parameters as described in [Table 14 on page 59](#) and click **Click to Submit Bundle AND Port Changes**.

**Table 14: CTP Bundle Multiservice IRIG-B Port Parameter Settings in CTPView**

Field	Function	Your Action
Port Description	Specifies a description for the port.	Enter a description of up to 64 alphanumeric characters. Do not use the following characters:  ( ; ' " ) ]
I/F Type	Specifies the daughter card as the interface type.	Select DCARD.
Multi-Service Mode	Specifies that the bundle will run in IRIG-B mode.	Select IRIG-B.
IRIG-B Source	<p>Specifies the direction of the circuit. Although the IP circuit connection through the network is full duplex, an IRIG-B circuit is a simplex application, and the interface can operate only in Rx or Tx mode and not both at the same time.</p> <p>(Although the bundle is by default a full duplex IP connection, you can configure it for simplex to save network bandwidth.)</p> <p>If the autonegotiation setting of the CTP Ethernet media and the far-end switch or router do not match, it is possible for the CTP Ethernet ports to be in a half-duplex state, although the duplex setting is not configurable and always assumed to be full-duplex on the CTP device. Starting with CTPOS Release 7.2, the half-duplex state at CTP network interface card (NIC) ports are acquired, regardless of the duplex setting configured on the far-end node. After the autonegotiation process is completed, if the CTP NIC cannot acquire full-duplex mode, then the interfaces are considered to be down and a log message is recorded in both the <b>/var/log/messages</b> directory and the syslog file stating that the interface is down due to a non-full duplex condition. You are prompted to verify the cable connection, speed, and duplex settings because the NIC link might be down.</p>	<p>Select one:</p> <ul style="list-style-type: none"> <li>• TX (signal enters CTP)—The end of the circuit that accepts IP packets, extracts the IRIG-B data codes, and transmits IRIG-B signaling output onto the cable.</li> <li>• RX (signal exits CTP)—The end of the circuit that recovers IRIG-B from the attached cable and generates IP packets toward the network.</li> </ul>

Table 14: CTP Bundle Multiservice IRIG-B Port Parameter Settings in CTPView (Continued)

Field	Function	Your Action
IRIG-B Data Rate	<p>Specifies the data rate on the IP connection.</p> <p>Note the following about setting the IRIG rate:</p> <ul style="list-style-type: none"> <li>• Unless network bandwidth is at a premium, we do not recommend that you change this value from the default of 16,000 bps.</li> <li>• Although the IRIG information can be transported through the network at the minimum configured rate (1000 bps), a CTP bundle running at this rate is subject to high latency.</li> </ul>	Enter a number from 1000 through 25,500 bps. The port speed must be a multiple of 100 bps.
Output High Volts Level	<p>This option appears only if you set the direction of the port to Tx.</p> <p>Specifies the high output level, which is measured in peak-to-peak voltage. This setting is based on a 50-ohm termination</p>	Enter a number from 0.00 through 7.85 volts peak-to-peak.
Output Low Volts Level	<p>This option appears only if you set the direction of the port to Tx.</p> <p>Specifies the low output level, which is measured in peak-to-peak voltage. This setting is based on a 50-ohm termination.</p>	Enter a number from 0.00 through 7.85 volts peak-to-peak.

**SEE ALSO**

| *Serial Multiservice Interface Module Overview*

**Configuring Multiservice TDC Mode Parameters for CTP Bundles (CTPView)**

Before you begin:

- Log in to the CTPView software at least at the Net\_Admin level.
- Connect the CTPView server to the CTP device for which you want to configure bundles.

To configure Multiservice TDC mode port parameters using CTPView:

1. In the side pane, select **Bundle > Configuration**.

2. Run your mouse over the **Display and Select an Existing Bundle** bar.
3. In the table of bundles, select the bundle that you want to modify.
4. Under **Bundle Options**, configure the parameters as described in [Table 15 on page 61](#) and click **Click to Submit Bundle AND Port Changes**.

**Table 15: CTP Bundle Multiservice TDC Port Parameter Settings in CTPView**

Field	Function	Your Action
Port Description	Specifies a description for the port.	Enter a description of up to 64 alphanumeric characters. Do not use the following characters:  ( ; ' " ) ]
I/F Type	Specifies the daughter card as the interface type.	Select DCARD.
Multi-Service Mode	Specifies that the bundle will run in TDC mode.	Select TDC.
TDC Source	Specifies the direction of the circuit.	Select one: <ul style="list-style-type: none"> <li>• Source (signal enters CTP)—End of the circuit that receives NRZ/IRIG data.</li> <li>• Destination (signal exits CTP)—End of the circuit that sends NRZ/IRIG data toward the network.</li> </ul>
TDC NRZ Rate	Specifies the NRZ data rate on the IP connection.	Enter a number from 500 through 5,000,000 bps in multiples of 500.

Table 15: CTP Bundle Multiservice TDC Port Parameter Settings in CTPView *(Continued)*

Field	Function	Your Action
TDC IRIG Output Level	<p>Specifies the output level.</p> <p>Note the following information about the values:</p> <ul style="list-style-type: none"> <li>• 0—There is no output.</li> <li>• 128—Unity gain, which means there is no attenuation or gain.</li> <li>• 255—Gain is 2:1.</li> </ul>	Enter a number from 0 through 255.

**SEE ALSO**

| *Serial Multiservice Interface Module Overview*

**Configuring Multiservice 4WTO Mode Port Parameters for CTP Bundles (CTPView)**

Before you begin:

- Log in to the CTPView software at least at the Net\_Admin level.
- Connect the CTPView server to the CTP device for which you want to configure bundles.

To configure Multiservice 4WTO mode port parameters using CTPView:

1. In the side pane, select **Bundle > Configuration**.
2. Run your mouse over the **Display and Select an Existing Bundle** bar.
3. In the table of bundles, select the bundle that you want to modify.
4. Under **Bundle Options**, configure the parameters as described in [Table 16 on page 63](#).
5. Click **Click to Submit Bundle AND Port Changes**.

Table 16: CTP Bundle Multiservice 4WTO Mode Port Parameter Settings in CTPView

Field	Function	Your Action
Port Description	Specifies a description for the port.	Enter a description of up to 64 alphanumeric characters. Do not use the following characters:  ( ; ' " ) ]
I/F Type	Specifies the daughter card as the interface type.	Select DCARD.
Multi-Service Mode	Specifies that the bundle will run in 4WTO mode.	Select 4WTO
4WTO Mode	Specifies whether this end of the circuit provides clocking or uses adaptive clocking.  If the CTP devices at both ends of the circuit are synchronized, you can configure both ends as Primary.	Select one: <ul style="list-style-type: none"> <li>• Primary—This end of the circuit provides clocking.</li> <li>• Member—This end of the circuit uses adaptive clocking.</li> </ul>
4WTO Channel	Specifies the channel or channels to enable.  Each CTP bundle can support either one or two channels.	Select one: <ul style="list-style-type: none"> <li>• Channel 0—Enables only channel 0.</li> <li>• Dual Channel—Enables both channel 0 and channel 1.</li> </ul>
4WTO Sample Rate [ KHz ]	Sample rate for audio circuits in kilohertz. The sample rate determines the audio quality and the network bandwidth needed.	Sample rate is fixed at 8 KHz, which corresponds to standard toll quality voice.
4WTO $\mu$ -law Encoding	4WTO $\mu$ -law encoding is not configurable.	4WTO $\mu$ -law encoding is fixed at DISABLED.

Table 16: CTP Bundle Multiservice 4WTO Mode Port Parameter Settings in CTPView (Continued)

Field	Function	Your Action
4WTO Squelch	<p>Enables or disables the active squelch function on the circuit.</p> <p>If enabled, specifies whether the squelch is active or inactive.</p> <p>The squelch function gates local audio output when DSR-A (channel 0) or RTS-A (channel 1) inputs are active or inactive.</p>	<p>Select one:</p> <ul style="list-style-type: none"> <li>• DISABLED—Disables the active squelch function on the circuit</li> <li>• ENABLED/ACTIVE—Squelch input is grounded and analog output is disabled.</li> <li>• ENABLED/INACTIVE—No signal is applied to the squelch input. Input is open and analog output is possible.</li> </ul>
4WTO Channel 0 Output Level	<p>Specifies the output level for channel 0.</p> <p>Note the following information about the values:</p> <ul style="list-style-type: none"> <li>• 0—There is no output.</li> <li>• 128—Unity gain, which means there is no attenuation or gain.</li> <li>• 255—Gain is 2:1.</li> </ul>	<p>Enter a number from 0 through 255.</p>
4WTO Channel 1 Output Level	<p>Specifies the output level for channel 1.</p> <p>Note the following information about the values:</p> <ul style="list-style-type: none"> <li>• 0—There is no output.</li> <li>• 128—Unity gain, which means there is no attenuation or gain.</li> <li>• 255—Gain is 2:1.</li> </ul>	<p>Enter a number from 0 through 255.</p>



**SEE ALSO**

*Serial Multiservice Interface Module Overview*

[Configuring 4WTO Port Parameters for CTP Bundles \(CTPView\) | 186](#)

## Configuring Serial Port Parameters for CTP Bundles (CTP Menu)

This topic describes how to configure port parameters for serial interfaces.

Before you begin:

- Disable the bundle before you modify the bundle options.

To configure serial port parameters for CTP bundles using the CTP Menu:

1. From the CTP Main Menu, select **1) Bundle Operations**.
2. Select **1) CTP**.
3. Select a bundle from the list.

If you select an active bundle, you are prompted to disable the bundle before configuring it.

4. Select **3) Port Config**.
5. Configure the options as described in [Table 17 on page 65](#).

**Table 17: CTP Bundle Serial Port Parameter Settings in the CTP Menu**

Field	Function	Your Action
Port descriptor text	Specifies a description for the port.	Enter a description of up to 64 alphanumeric characters. Do not use the following characters:  ( ; ' " ) ]
Interface	Displays the menu used to configure the interface type, mode, and encoding.	Select <b>2) Interface</b> .

Table 17: CTP Bundle Serial Port Parameter Settings in the CTP Menu *(Continued)*

Field	Function	Your Action
Type	<p>Specifies the electrical standard used on the serial interface.</p> <p>You can install the following optional daughter cards on a serial interface:</p> <ul style="list-style-type: none"> <li>• T1/E1 (CTP1000 and CTP2000 series)</li> <li>• 4WTO (CTP1000 and CTP2000 series)</li> <li>• IRIG-B (CTP2000 series only)</li> <li>• Multiservice Daughter Cards (CTP 2000 and CTP150 series)</li> </ul>	<p>Select one:</p> <ul style="list-style-type: none"> <li>• OFF—Do not set the interface type to OFF.</li> <li>• EIA-530</li> <li>• EIA-530A</li> <li>• RS-232</li> <li>• V.35</li> <li>• Optional Interface</li> </ul>
Mode	<p>Specifies that the interface is connected to a data communication equipment (DCE) device or to a data terminal equipment (DTE) device.</p>	<p>Select one:</p> <ul style="list-style-type: none"> <li>• DCE—The interface is connected to a DCE device.</li> <li>• DTE—The interface is connected to a DTE device.</li> </ul>

Table 17: CTP Bundle Serial Port Parameter Settings in the CTP Menu *(Continued)*

Field	Function	Your Action
Encoding	<p>Specifies the serial encoding method used on this bundle.</p> <p>When you change the encoding method, the clocking configuration changes to the default configuration for the encoding method that you select.</p>	<p>Select one:</p> <ul style="list-style-type: none"> <li>• NRZ—Nonreturn to zero (NRZ) line encoding.</li> <li>• ISOCH—Isochronous encoding. Isochronous encoding does not provide or embed the clock in the data.</li> <li>• CDI—Conditioned diphase. Conditioned diphase encoding recovers and embeds the clock in the data signal. CDI encoding provides a speed of up to 4608 Kbps.</li> <li>• TRANS—Transparent encoding. See <a href="#">"Configuring Transparent Encoding for CTP Bundles (CTP Menu)"</a> on page 69.</li> <li>• TDM—Additional data is interleaved with the port's serial data. This option is used on TDM/TDC high-speed ports and is available only on even-numbered ports on a CTP 2000 serial module. See <a href="#">"Configuring Bundle Pairs for TDM/TDC Operation (CTP Menu)"</a> on page 72.</li> <li>• TRANS8—Extension of the TRANS encoding. Compared with TRANS encoding, which sends four signals in each direction, with TRANS8 encoding, bandwidth is doubled and eight signals can be sampled and transported.</li> </ul>

Table 17: CTP Bundle Serial Port Parameter Settings in the CTP Menu *(Continued)*

Field	Function	Your Action
		<p>This allows signals to be sent from additional interfaces that were not supported in TRANS 4.</p>
Enter Synthesized port rate (KHz)	<p>Specifies the speed of the port. In networks without bandwidth constraints, we recommend a multiple of 10.</p> <p>The port speed recommendations vary according to encoding type:</p> <ul style="list-style-type: none"> <li>• For transparent mode circuits, the port speed is the sample rate for user data. Therefore, the port rate should be a multiple of the user data rate.</li> <li>• For CDI circuits, the maximum port speed is limited to 4608 Kbps.</li> </ul> <p>The port speed also varies depending on hardware:</p> <ul style="list-style-type: none"> <li>• CTP2000 devices cannot have an aggregate port rate greater than 114.688 Mbps.</li> </ul>	Enter a number from 0.00100 through 12880.00000 KHz.
Enable adaptive clocking?	<p>Specifies whether adaptive clocking is enabled for this circuit.</p> <p>If both end nodes are not locked to a clock reference, we recommend that you enable one end (not both) for adaptive clocking</p> <p>Appears only if you select ISOCH, CDI, TRANS, or TDM encoding.</p>	Specify y (yes) or n (no).

Table 17: CTP Bundle Serial Port Parameter Settings in the CTP Menu *(Continued)*

Field	Function	Your Action
Initialize adaptive clocking parameters? y[n]: y	<p>If you enabled adaptive clocking, specifies whether or not to initialize adaptive clocking parameters to their default values, which depend on port speed, packet size, and buffering parameters set on the bundle.</p> <p>We recommend the following settings:</p> <ul style="list-style-type: none"> <li>• If you are configuring the bundle for adaptive clocking for the first time, enter <b>y</b>.</li> <li>• If you have previously configured the bundle to optimize adaptive clocking for this network, enter <b>n</b>.</li> </ul>	Specify y (yes) or n (no).
TDC Clk/Data on port N+1	This option is used for TDM/TDC operation. See <a href="#">"Configuring the High-Speed CTP Bundle for TDM/TDC Operation (CTP Menu)"</a> on page 73.	
TDM rates	This option is used for TDM/TDC operation. See <a href="#">"Configuring the High-Speed CTP Bundle for TDM/TDC Operation (CTP Menu)"</a> on page 73.	

## Configuring Transparent Encoding for CTP Bundles (CTP Menu)

This topic describes how to configure transparent encoding for CTP bundles. You must configure transparent encoding on each end of the circuit.

To reduce transport latency, we recommend that you use the smallest buffer values possible for networks.

**NOTE:** There are two modes of transparent encoding. They are Transparent 4 mode (**TRANS**) and Transparent 8 mode (**TRANS8**). Transparent 8 mode is only supported on CTPOS release 6.4 and later. This topic describes how to configure the **TRANS** encoding.

Before you begin:

- Disable the bundle before you modify the bundle options.

To configure transparent encoding using the CTP Menu:

1. From the CTP Main Menu, select **1) Bundle Operations**.
2. Select **1) CTP**.
3. Select a bundle from the list.

If you select an active bundle, you are prompted to disable the bundle before configuring it.

4. Select **3) Port Config**.
5. Select **2) Interface**.
6. Set **Mode** to **DCE** and set **Encoding** to **TRANS**.
7. Follow the onscreen instructions to configure the options as described in [Table 18 on page 70](#).

**Table 18: Transparent Mode Parameter Settings in the CTP Menu**

Field	Function	Your Action
Enter connected device rate (KHz)	Specifies the speed of the port. For transparent mode circuits, the port speed is the sample rate for user data. Therefore, the port rate should be a multiple of the user data rate. In networks without bandwidth constraints, we recommend a multiple of 10. The port speed is calculated as 'Connected device rate' x 'Oversampling multiplier'.  <b>NOTE:</b> The calculated port speed must be in the range from 0.001 through 1024.0 KHz.	Enter a number from 0.000250 through 256.000000 KHz.
Enter oversampling multiplier	Specifies the multiplier factor for calculating the port speed. A good default multiple in networks without bandwidth constraints would be 10.	Enter an even number from 4 through 100.

Table 18: Transparent Mode Parameter Settings in the CTP Menu (Continued)

Field	Function	Your Action
Enable adaptive clocking?	Specifies whether adaptive clocking is enabled for this circuit.  If both end nodes are not locked to a clock reference, we recommend that you enable one end (not both) for adaptive clocking	Specify y (yes) or n (no).
Initialize adaptive clocking parameters? y[n]: y	If you enabled adaptive clocking, specifies whether or not to initialize adaptive clocking parameters to their default values, which depend on port speed, packet size, and buffering parameters set on the bundle.  We recommend the following settings: <ul style="list-style-type: none"> <li>• If you are configuring the bundle for adaptive clocking for the first time, enter <b>y</b>.</li> <li>• If you have previously configured the bundle to optimize adaptive clocking for this network, enter <b>n</b>.</li> </ul>	Specify y (yes) or n (no).
Enable 16 bit FIFO?	Enables or disables the phase-correction FIFO buffer. This FIFO buffer aligns the clock and data phase relationship on a TRANS encoded circuit in which the clock travels in one direction and the data travels in the opposite direction.  Enable this FIFO buffer at one end of the circuit, but not at both ends.	Specify y (yes) or n (no).
Invert FIFO Write clock?	Specifies whether or not to invert the FIFO write clock.	Specify y (yes) or n (no).
Invert FIFO Read clock?	Specifies whether or not to invert the FIFO read clock.	Specify y (yes) or n (no).

Table 18: Transparent Mode Parameter Settings in the CTP Menu *(Continued)*

Field	Function	Your Action
Use ST lead (instead of RTS/CTS)?	<p>Specifies that the circuit uses the ST lead instead of the RTS and CTS leads to sample local SD/TT/RTS/DTR signals and forward them to the remote RD/RT/CTS/DSR signals.</p> <p>The RTS and DTR leads are subject to additional delay and jitter because they are signaling leads. On higher-speed circuits, the delay and jitter on these paths make the signal choices nonoptimal. Therefore, you can specify that the circuit uses the ST lead instead of the RTS and CTS leads, which will not have this delay and jitter.</p>	Specify y (yes) or n (no).
Is ST an input?	If you specify that the circuit uses the ST lead instead of the RTS and CTS leads, you can specify whether the ST lead is an input lead.	Specify y (yes) or n (no).

## RELATED DOCUMENTATION

[Transparent Encoding Applications and Support Overview | 22](#)

[How Basic Transparent Encoding Works | 23](#)

[Configuring Transparent Encoding for CTP Bundles \(CTPView\) | 167](#)

[Using Phase-Correction FIFO Buffer with Transparent Encoding | 24](#)

[Using Send Timing \(ST\) Clocking for Higher Speed Circuits with Transparent Encoding | 27](#)

## Configuring Bundle Pairs for TDM/TDC Operation (CTP Menu)

### IN THIS SECTION

- [Configuring the High-Speed CTP Bundle for TDM/TDC Operation \(CTP Menu\) | 73](#)
- [Configuring the Low-Speed CTP Bundle for TDM/TDC Operation \(CTP Menu\) | 74](#)



The TDM/TDC feature is supported on CTP2000 serial interfaces. TDM/TDC operation requires both a low-speed bundle and a high-speed bundle. This topic describes how to configure the high-speed and low-speed bundle port options when used for TDM/TDC bundles using CTP Menu.

## Configuring the High-Speed CTP Bundle for TDM/TDC Operation (CTP Menu)

Configure the high-speed bundle on an even-numbered port.

Before you begin:

- Disable the bundle before you modify the bundle options.

To configure a high-speed CTP bundle for TDM/TDC operation using the CTP Menu:

1. From the CTP Main Menu, select **1) Bundle Operations**.
2. Select **1) CTP**.
3. Select a bundle from the list. You must configure the bundle on an even-numbered port.  
If you select an active bundle, you are prompted to disable the bundle before configuring it.
4. Select **3) Port Config**.
5. Select **2) Interface**.
6. Select **3) Encoding**.
7. Select **5) TDM**.
8. Follow the onscreen instructions to configure the parameters as described in [Table 19 on page 73](#).
9. Configure the rest of the bundle as you normally would.

**Table 19: High-Speed CTP Bundle Parameters for TDM/TDC Operation in the CTP Menu**

Field	Function	Your Action
TDC Clk/Data on port N+1	<p>Specifies that the TDM function is TDC Clk/Data on port N+1.</p> <p>This option is available only on even-numbered ports on a CTP2000 serial module, and when the serial encoding parameter is set to TDM.</p> <p>TDC Clk/Data on port N+1 oversamples the incoming clock (TT) and data (SD) from the adjacent port above this one (N+1) at this port's clock rate, and embeds it in its data. At the remote end of the network, the embedded circuit data is recovered and exits the node on port N+1 as RT and RD outputs.</p> <p>Because of the direct interleaving of two ports' data, TDC is maintained between these two ports with an accuracy of one bit time at this port's data rate.</p>	Press Enter.

**Table 19: High-Speed CTP Bundle Parameters for TDM/TDC Operation in the CTP Menu (Continued)**

Field	Function	Your Action
TDM rates	<p>Specifies the number of bits out of 32 that are used for the TDM function (and not for local serial port data).</p> <p>Appears only if you selected TDM encoding.</p> <p>Keep in mind the following when you configure the TDM rate:</p> <ul style="list-style-type: none"> <li>• If the rate is too low, the bundle may not carry the low-speed data because of insufficient oversampling.</li> <li>• If the rate is too high, the low-speed circuit will still run, but will likely use more bandwidth than necessary.</li> <li>• You may want to configure a higher rate to increase the TDM rate to reduce jitter on the low-speed clock and data signals.</li> </ul>	<p>Select one:</p> <ul style="list-style-type: none"> <li>• 16</li> <li>• 8</li> <li>• 4</li> <li>• 2</li> </ul>

### Configuring the Low-Speed CTP Bundle for TDM/TDC Operation (CTP Menu)

Configure the low-speed bundle on an odd-numbered port that is one higher than the corresponding high-speed bundle.

Before you begin:

- Disable the bundle before you modify the bundle options.

To configure the low-speed CTP bundle using CTP Menu:

1. From the CTP Main Menu, select **1) Bundle Operations**.
2. Select **1) CTP**.
3. Select a bundle from the list. The bundle must be configured on an even-numbered port.  
If you select an active bundle, you are prompted to disable the bundle before configuring it.
4. Select **3) Port Config**.
5. Select **3) Clock Config**.
6. Select **1) Port Clock Config**.
7. Select **8) TDM/TDC - Interleaved Slow Port**.

**NOTE:** Do not configure any other bundle parameters.

## RELATED DOCUMENTATION

| [TDM/TDC Encoding Overview](#) | 30

## Configuring T1 and E1 Port Parameters for CTP Bundles (CTP Menu)

This topic describes how to configure port parameters for T1/E1 interfaces.

Before you begin:

- Disable the bundle before you modify the bundle options.

To configure port parameters for T1/E1 daughter cards for CTP bundles using the CTP Menu:

1. From the CTP Main Menu, select **1) Bundle Operations**.
2. Select **1) CTP**.
3. Select a bundle from the list. The bundle port must have a T1/E1 daughter card installed.  
If you select an active bundle, you are prompted to disable the bundle before configuring it.
4. Select **3) Port Config**.
5. Select **2) Interface**.
6. Select **1) Type** and set the type to **Optional Interface: T1/E1**.
7. Follow the onscreen instructions and configure the options as described in [Table 20 on page 76](#).  
The options vary depending on whether the bundle is T1 or E1 and whether fractional T1 or E1 is configured.
8. To configure clocking for the port, select **3) Clock Config** and configure the Clock Config option as described in [Table 20 on page 76](#).

**NOTE:** BITS input is a T1/E1 line interface unit (LIU), with AMI (alternate mark inversion) encoding enabled and B8ZS/HDB3 (Zero Suppression) disabled. The equalization is set for a 0-133 feet cable. An internal 100 ohm termination is present, although it might need to be externally augmented based on the type of cabling used. Any valid AMI signal works properly and it is not restricted to only the "all 1" BITS signal but the ones density must be sufficient to prevent LOS (according to the ITU G.775 recommendation). The TTL input has a slice point of  $3.3V/2 = 1.65V$  relative to chassis ground (GND). Therefore, any signal on the coaxial center conductor that transitions through that voltage registers a transition. There are many signals, besides TTL, that satisfy this criteria. An external termination must be provided that matches the impedance of the cable that goes to the BNC connector.

If you can configure the rate in CTP menu, then the TTL supports a frequency of 2048 KHz for the TTL clock input, provided the signal is good and noise-free (terminated properly). TTL is rate-agile, while BITS is restricted to T1/E1 frequencies.

The TTL input is high-impedance (no on-board termination provided) because a variety of cable types might exist that you can use to drive signal to this connector, such as RG-58 coax (50 ohm), RG-59 coax (75 ohm), or twisted pair (100-120 ohm). Instead of applying a particular impedance termination on the board and have it incorrectly done, we recommend that you configure the impedance termination based on your network environment. For example, a 50 ohm termination is needed if you are using RG-58/U coax cable, which has 50 ohm impedance.

**Table 20: CTP Bundle T1/E1 Port Parameter Settings in the CTP Menu**

Field	Function	Your Action
Port descriptor	Specifies a description for the port.	Enter a description of up to 64 alphanumeric characters. Do not use the following characters:  ( ; ' " ) ]
Type	Specifies the type of interface.	Select one: <ul style="list-style-type: none"> <li>• T1</li> <li>• E1</li> <li>• Fractional T1</li> <li>• Fractional E1</li> </ul>
Option (for T1)	Specifies the T1 encoding method used on this bundle.	Select one: <ul style="list-style-type: none"> <li>• B8ZS</li> <li>• AMI</li> </ul>

Table 20: CTP Bundle T1/E1 Port Parameter Settings in the CTP Menu *(Continued)*

Field	Function	Your Action
Option (for E1)	For E1 interfaces, configure the termination to work with either coaxial or RJ-48.	Select one: <ul style="list-style-type: none"> <li>• RJ48</li> <li>• COAX</li> </ul>
Clock synthesizer	The following clock synthesizer settings are set by the software, and you cannot change them: <ul style="list-style-type: none"> <li>• For T1, the clock synthesizer is set to 1544 KHz.</li> <li>• For E1 the clock synthesizer is set to 2048 KHz.</li> </ul>	
Fractional channels	Specifies the number of fractional T1 or E1 channels to transport.	For T1, select a number from 1 through 24.  For E1, select a number from 1 through 31.
Fractional Frame Transport	For fractional T1, enables or disables fractional frame transport.	Select one: <ul style="list-style-type: none"> <li>• y (yes)—Frame Transport—Framing bit is transported along with data, which results in data alignment with the frame.</li> <li>• n (no)t—Framing bit is not transported.</li> </ul>

Table 20: CTP Bundle T1/E1 Port Parameter Settings in the CTP Menu *(Continued)*

Field	Function	Your Action
CAS support	Specifies the signaling method used for fractional E1.	Select one: <ul style="list-style-type: none"> <li>• n (no)—Common channel signaling (CSS) is used. The common channel carries data messages that convey signaling for the circuits between two devices.</li> <li>• y (yes)—Channel associated signaling (CAS) is used. Each traffic channel has a dedicated signaling channel (channel 16).</li> </ul>

Table 20: CTP Bundle T1/E1 Port Parameter Settings in the CTP Menu *(Continued)*

Field	Function	Your Action
Clock Config	Specifies the type of clocking for the port. The default value for Clock Config is <b>CTP is Loop Timed</b> .	<p>Select one:</p> <ul style="list-style-type: none"> <li>• CTP is Clock Source—The PBX either returns the clock received from the CTP device, or it returns a clock that is traceable to the same source as the CTP node clock reference. You typically use this configuration when you configure the CTP device with a clock reference input.</li> <li>• CTP is Loop Timed—The PBX provides the clock, and the CTP device returns the same clock to the PBX. You typically use this configuration when the PBX has the more accurate clock source. You can configure the far end of the circuit with adaptive clocking to recover this clock if necessary.</li> <li>• CTP is Clock Source (Adaptive End)—The PBX returns the clock received from the CTP device, and the CTP device uses the adaptive recovered clock. You typically use this configuration when the CTP device does not have a reference input and the PBX typically requires a clock from the distant PBX.</li> </ul>

## Configuring Multiservice Port Parameters for CTP Bundles (CTP Menu)

### IN THIS SECTION

- [Configuring Multiservice Audio Mode Port Parameters for CTP Bundles \(CTP Menu\) | 80](#)
- [Configuring Multiservice IRIG-B Mode Port Parameters for CTP Bundles \(CTP Menu\) | 83](#)
- [Configuring Multiservice TDC Mode Parameters for CTP Bundles \(CTP Menu\) | 86](#)
- [Configuring Multiservice 4WTO Mode Port Parameters for CTP Bundles \(CTP Menu\) | 87](#)

### Configuring Multiservice Audio Mode Port Parameters for CTP Bundles (CTP Menu)

Before you begin:

- Disable the bundle before you modify the bundle options.

To configure Multiservice audio mode port parameters using the CTP Menu:

1. From the CTP Main Menu, select **1) Bundle Operations**.
2. Select **1) CTP**.
3. Select a bundle from the list.  
If you select an active bundle, you are prompted to disable the bundle before configuring it.
4. Select **3) Port Config**.
5. Select **2) Interface**.
6. Select **1) Type**, and set the type to **Optional Interface: MultiSvc**.
7. Follow the onscreen instructions and configure the options as described in [Table 21 on page 80](#).

**Table 21: CTP Bundle Multiservice Audio Mode Port Parameter Settings in the CTP Menu**

Field	Function	Your Action
Mode	Specifies that the bundle will run in audio mode.	Select AUDIO.



Table 21: CTP Bundle Multiservice Audio Mode Port Parameter Settings in the CTP Menu (Continued)

Field	Function	Your Action
Primary/Member	<p>Specifies whether this end of the circuit provides clocking or uses adaptive clocking.</p> <p>If the CTP devices at both ends of the circuit are synchronized, you can configure both ends as Primary.</p>	<p>Select one:</p> <ul style="list-style-type: none"> <li>• Primary—This end of the circuit provides clocking.</li> <li>• Member—This end of the circuit uses adaptive clocking.</li> </ul>
Dual Channel	<p>Two channels are supported—channel 0 and channel 1.</p> <p>Enables or disables the use of both channels.</p>	<p>Select one:</p> <ul style="list-style-type: none"> <li>• Disable—Channel 0 is the only active channel.</li> <li>• Enable—Both channel 0 and channel 1 are active.</li> </ul>
Audio Sample Rate	<p>Specifies the sample rate for audio circuits in kilohertz. The sample rate determines the audio quality and the network bandwidth needed. Higher sample rates create an IP data flow that requires higher bandwidth.</p> <p>8 KHz corresponds to standard toll quality voice.</p> <p>48 KHz corresponds to CD quality audio.</p>	<p>Select one:</p> <ul style="list-style-type: none"> <li>• 8</li> <li>• 12</li> <li>• 16</li> <li>• 24</li> <li>• 32</li> <li>• 48</li> </ul>
μ-law Encoding:	<p>Enables or disables μ-law encoding. Standard audio code samples are 16 bits. If you enable μ-law encoding, the 16-bit samples are converted to 8 bits, consuming half of the bandwidth without significant audio degradation.</p>	<p>Select one:</p> <ul style="list-style-type: none"> <li>• Disable—Generates 16-bit audio samples.</li> <li>• Enable—Generates 8-bit audio samples.</li> </ul>

Table 21: CTP Bundle Multiservice Audio Mode Port Parameter Settings in the CTP Menu (Continued)

Field	Function	Your Action
Talk Squelch	<p>Enables or disables the active squelch function on the circuit.</p> <p>If enabled, specifies whether the squelch is active or inactive.</p> <p>The squelch function gates local audio output when DSR-A (channel 0) or RTS-A (channel 1) inputs are active or inactive.</p>	<p>Select one:</p> <ul style="list-style-type: none"> <li>• Disable—Disables the active squelch function on the circuit (audio output is always enabled).</li> <li>• Enable and active—Squelch input is grounded and analog output is disabled.</li> <li>• Enable and inactive—No signal is applied to the squelch input. Input is open and analog output is possible.</li> </ul>
Ch 0 Output Level: 1.00x (decimal 128)	<p>Specifies the output level for channel 0.</p> <p>Note the following information about the values:</p> <ul style="list-style-type: none"> <li>• 0—There is no output.</li> <li>• 128—Unity gain, which means there is no attenuation or gain.</li> <li>• 255—Gain is 2:1.</li> </ul>	Enter a number from 0 through 255.
Ch 1 Output Level: 1.00x (decimal 128)	<p>Specifies the output level for channel 1.</p> <p>Note the following information about the values:</p> <ul style="list-style-type: none"> <li>• 0—There is no output.</li> <li>• 128—Unity gain, which means there is no attenuation or gain.</li> <li>• 255—Gain is 2:1.</li> </ul>	Enter a number from 0 through 255.

**SEE ALSO**

| *Serial Multiservice Interface Module Overview*

**Configuring Multiservice IRIG-B Mode Port Parameters for CTP Bundles (CTP Menu)**

Before you begin:

- Disable the bundle before you modify the bundle options.

To configure Multiservice IRIG-B mode port parameters using the CTP Menu:

1. From the CTP Main Menu, select **1) Bundle Operations**.
2. Select **1) CTP**.
3. Select a bundle from the list.  
If you select an active bundle, you are prompted to disable the bundle before configuring it.
4. Select **3) Port Config**.
5. Select **2) Interface**.
6. Select **1) Type** and set the type to **Optional Interface: MultiSvc**.
7. Follow the onscreen instructions and configure the options as described in [Table 22 on page 83](#).

**Table 22: CTP Bundle Multiservice IRIG-B Port Parameter Settings in the CTP Menu**

Field	Function	Your Action
Mode	Specifies that the bundle will run in IRIG-B mode.	Select IRIG.

Table 22: CTP Bundle Multiservice IRIG-B Port Parameter Settings in the CTP Menu *(Continued)*

Field	Function	Your Action
Src/Dest	<p>Specifies the direction of the circuit. Although the IP circuit connection through the network is full duplex, an IRIG-B circuit is a simplex application, and the interface can operate only in Rx or Tx mode and not both at the same time.</p> <p>(Although the bundle is by default a full duplex IP connection, you can configure it for simplex to save network bandwidth.)</p>	<p>Specify yes or no to the question: Is this an IRIG-B source end (IRIG-B signal enters CTP)?</p> <ul style="list-style-type: none"> <li>• Yes (y)—Sets direction to Rx. This end of the circuit recovers IRIG-B from the attached cable and generates IP packets toward the network.</li> <li>• No (n)—Sets the direction to Tx. This end of the circuit accepts IP packets, extracts the IRIG-B data codes, and transmits IRIG-B signaling output onto the cable.</li> </ul> <p>If the autonegotiation setting of the CTP Ethernet media and the far-end switch or router do not match, it is possible for the CTP Ethernet ports to be in a half-duplex state, although the duplex setting is not configurable and always assumed to be full-duplex on the CTP device. Starting with CTPOS Release 7.2, the half-duplex state at CTP network interface card (NIC) ports are acquired, regardless of the duplex setting configured on the far-end node. After the autonegotiation process is completed, if the CTP NIC cannot acquire full-duplex mode, then the interfaces are considered to be down and a log message is recorded in both the <b>/var/log/messages</b> directory and the syslog file stating that the interface is down due to a non-full duplex condition. You are prompted to verify the cable connection, speed, and duplex</p>

Table 22: CTP Bundle Multiservice IRIG-B Port Parameter Settings in the CTP Menu *(Continued)*

Field	Function	Your Action
		settings because the NIC link might be down.
IRIG Rate	<p>Specifies the data rate on the IP connection.</p> <p>Note the following about setting the IRIG rate:</p> <ul style="list-style-type: none"> <li>• Unless network bandwidth is at a premium, we do not recommend that you change this value from the default of 16,000 bps.</li> <li>• Although the IRIG information can be transported through the network at the minimum configured rate (1000 bps), a CTP bundle running at this rate is subject to high latency.</li> </ul>	Enter a number from 1000 through 25,500 bps. The port speed must be a multiple of 100 bps.
Output High Level	<p>This setting applies only if you set the direction of the port to Tx.</p> <p>Specifies the high output level, which is measured in peak-to-peak voltage. This setting is based on a 50-ohm termination.</p>	Enter a number from 0.00 through 7.85 volts peak-to-peak.
Output Low Level	<p>This setting applies only if you set the direction of the port to Tx.</p> <p>Specifies the low output level, which is measured in peak-to-peak voltage. This setting is based on a 50-ohm termination.</p>	Enter a number from 0.00 through 7.85 volts peak-to-peak.

**SEE ALSO**

| *Serial Multiservice Interface Module Overview*

**Configuring Multiservice TDC Mode Parameters for CTP Bundles (CTP Menu)**

Before you begin:

- Disable the bundle before you modify the bundle options.

To configure Multiservice TDC mode port parameters using the CTP Menu:

1. From the CTP Main Menu, select **1) Bundle Operations**.
2. Select **1) CTP**.
3. Select a bundle from the list.  
If you select an active bundle, you are prompted to disable the bundle before configuring it.
4. Select **3) Port Config**.
5. Select **2) Interface**.
6. Select **1) Type** and set the type to **Optional Interface: MultiSvc**.
7. Follow the onscreen instructions and configure the options as described in [Table 23 on page 86](#).

**Table 23: CTP Bundle Multiservice TDC Port Parameter Settings in the CTP Menu**

Field	Function	Your Action
Mode	Specifies that the bundle will run in TDC mode.	Select TDC/IRIG.
Src/Dest	Specifies the direction of the circuit.	Select one: <ul style="list-style-type: none"> <li>• Src (signal enters CTP)—End of the circuit that receives NRZ/IRIG data.</li> <li>• Dst (signal exits CTP)—End of the circuit that sends NRZ/IRIG data toward the network.</li> </ul>
NRZ/Rate	Specifies the data rate on the IP connection.	Enter a number from 500 through 5,000,000 bps. The port speed must be a multiple of 500 bps.

Table 23: CTP Bundle Multiservice TDC Port Parameter Settings in the CTP Menu (*Continued*)

Field	Function	Your Action
IRIG Output Level	<p>Specifies the output level.</p> <p>Note the following information about the values:</p> <ul style="list-style-type: none"> <li>• 0—There is no output.</li> <li>• 128—Unity gain, which means there is no attenuation or gain.</li> <li>• 255—Gain is 2:1.</li> </ul>	Enter a number from 0 through 255.

**SEE ALSO**

| *Serial Multiservice Interface Module Overview*

**Configuring Multiservice 4WTO Mode Port Parameters for CTP Bundles (CTP Menu)**

Before you begin:

- Disable the bundle before you modify the bundle options.

To configure Multiservice 4WTO mode port parameters using the CTP Menu:

1. From the CTP Main Menu, select **1) Bundle Operations**.
2. Select **1) CTP**.
3. Select a bundle from the list. The bundle port must have a 4WTO daughter card installed.  
If you select an active bundle, you are prompted to disable the bundle before configuring it.
4. Select **3) Port Config**.
5. Select **2) Interface**.
6. Select **1) Type** and set the type to **Optional Interface: MultiSvc**.
7. Configure the options as described in [Table 24 on page 88](#).

Table 24: CTP Bundle Multiservice 4WTO Port Parameter Settings in the CTP Menu

Field	Function	Your Action
Mode	Specifies that the bundle will run in 4WTO mode.	Select 4WTO-Em.
Primary/Member	Specifies whether this end of the circuit provides clocking or uses adaptive clocking.  If the CTP devices at both ends of the circuit are synchronized, you can configure both ends as Primary.	Select one: <ul style="list-style-type: none"> <li>• Primary—This end of the circuit provides clocking.</li> <li>• Member—This end of the circuit uses adaptive clocking.</li> </ul>
Dual Channel	Two channels are supported—channel 0 and channel 1.  Enables or disables the use of both channels.	Select one: <ul style="list-style-type: none"> <li>• Disable—Channel 0 is the only active channel.</li> <li>• Enable—Both channel 0 and channel 1 are active.</li> </ul>
Talk Squelch	Enables or disables the active squelch function on the circuit.  If enabled, specifies whether the squelch is active or inactive.  The squelch function gates local audio output when DSR-A (channel 0) or RTS-A (channel 1) inputs are active or inactive.	Select one: <ul style="list-style-type: none"> <li>• Disable—Disables the active squelch function on the circuit.</li> <li>• Enable and active—Squelch input is grounded and analog output is disabled.</li> <li>• Enable and inactive—No signal is applied to the squelch input. Input is open and analog output is possible.</li> </ul>



Table 24: CTP Bundle Multiservice 4WTO Port Parameter Settings in the CTP Menu *(Continued)*

Field	Function	Your Action
Ch 0 Output Level: 1.00x (decimal 128)	<p>Specifies the output level for channel 0.</p> <p>Note the following information about the values:</p> <ul style="list-style-type: none"> <li>• 0—There is no output.</li> <li>• 128—Unity gain, which means there is no attenuation or gain.</li> <li>• 255—Gain is 2:1.</li> </ul>	Enter a number from 0 through 255.
Ch 1 Output Level: 1.00x (decimal 128)	<p>Specifies the output level for channel 1.</p> <p>Note the following information about the values:</p> <ul style="list-style-type: none"> <li>• 0—There is no output.</li> <li>• 128—Unity gain, which means there is no attenuation or gain.</li> <li>• 255—Gain is 2:1.</li> </ul>	Enter a number from 0 through 255.

**SEE ALSO**

*Serial Multiservice Interface Module Overview*

*Configuring 4WTO Daughter Cards to Interoperate with Multiservice Interface Modules (CTP Menu)*

## Configuring 4WTO Port Parameters for CTP Bundles (CTP Menu)

For CTP bundles, you can configure a 4WTO daughter card installed on a serial interface module.

You do not need to configure port speed and clocking for the analog 4WTO interface. Selecting this interface causes the port speed and clocking to be automatically configured.

You can set up 4WTO daughter cards to interoperate with Multiservice Interface modules. Interoperability of Multiservice Interface modules with 4WTO daughter cards requires the following:

- Firmware revision 4 or later on the 4WTO daughter card.
- CTPView releases 3.4R4 or later or releases 4.x or later.
- CTPOS release 6.0 or later.
- Channel 1 cannot be the enabled channel.

Before you begin:

- Disable the bundle before you modify the bundle options.

To configure port parameters for 4WTO daughter cards for CTP bundles using the CTP Menu:

1. From the CTP Main Menu, select **1) Bundle Operations**.
2. Select **1) CTP**.
3. Select a bundle from the list. The bundle port must have a 4WTO daughter card installed.  
If you select an active bundle, you are prompted to disable the bundle before configuring it.
4. Select **3) Port Config**.
5. Select **2) Interface**.
6. Select **1) Type** and set the type to **Optional Interface: Voice 4W/TO**.
7. Follow the onscreen instructions.

To prevent voice channels from generating occasional noise bursts caused by unsynchronized nodes, we recommend that you either enable adaptive clocking on one end of the voice port (not both) or lock both ends of the voice port to clock references.

8. Configure the options as described in [Table 25 on page 90](#).

**Table 25: CTP Bundle 4WTO Port Parameter Settings in the CTP Menu**

Field	Function	Your Action
Dual Channel	Each CTP port with the daughter card installed can support either one or two channels.  Enables or disables the use of both channels.	Select one: <ul style="list-style-type: none"> <li>• Disabled—Only one channel can be enabled.</li> <li>• Enabled—Channels 1 and 2 are enabled.</li> </ul>

Table 25: CTP Bundle 4WTO Port Parameter Settings in the CTP Menu *(Continued)*

Field	Function	Your Action
Enabled Channel	If Dual Channel is disabled, specifies which voice channel you want to enable on the 4WTO daughter card.	Enter either 0 or 1.
Input Level	<p>Specifies the input level for the 4WTO daughter card.</p> <p>Note the following information about the values:</p> <ul style="list-style-type: none"> <li>• 0—Gain is 2:3 (signal is attenuated 33% or 1.8 dB).</li> <li>• 25—Unity gain, which means there is no attenuation or gain.</li> <li>• 255—Gain is 4:1 (signal is amplified 400% or 6 dB).</li> </ul> <p>Intermediate values are derived with linear interpolation. The actual gain depends on the impedance of the attached device.</p>	Enter a number from 0 through 255.

Table 25: CTP Bundle 4WTO Port Parameter Settings in the CTP Menu *(Continued)*

Field	Function	Your Action
Output Level	<p>Specifies the output level for the 4WTO daughter card.</p> <p>Note the following information about the values:</p> <ul style="list-style-type: none"> <li>• 0—Gain is 2:3 (signal is attenuated 33% or 1.8 dB).</li> <li>• 25—Unity gain, which means there is no attenuation or gain.</li> <li>• 255—Gain is 4:1 (signal is amplified 400% or 6 dB).</li> </ul> <p>Intermediate values are derived with linear interpolation. The actual gain depends on the impedance of the attached device.</p>	Enter a number from 0 through 255.
Talk Squelch	<p>Enables or disables the active squelch function on the circuit.</p> <p>If enabled, specifies whether the squelch is active or inactive.</p> <p>The squelch function gates local audio output when DSR-A (channel 1) or RTS-A (channel 0) inputs are active or inactive.</p>	<p>Select one:</p> <ul style="list-style-type: none"> <li>• DISABLED—Disables the active squelch function on the circuit</li> <li>• ENABLED/ACTIVE—Squelch input is grounded and analog output is disabled.</li> <li>• ENABLED/INACTIVE—No signal is applied to the squelch input. Input is open and analog output is possible.</li> </ul>

Table 25: CTP Bundle 4WTO Port Parameter Settings in the CTP Menu *(Continued)*

Field	Function	Your Action
Ms interwork	<p>Enables or disables interoperability of the 4WTO daughter card with Multiservice Interface modules.</p> <p>When you enable interoperability of the 4WTO daughter card with Multiservice Interface modules, the port speed for the bundle is set as follows:</p> <ul style="list-style-type: none"> <li>• 64 when only channel 0 is enabled.</li> <li>• 128 when dual channel is enabled.</li> </ul>	<ul style="list-style-type: none"> <li>• Enabled—Interoperability with the Multiservice Interface module is enabled.</li> <li>• Disabled—Interoperability with the Multiservice Interface module is disabled.</li> </ul>
Clock Config	<p>Specifies the type of clocking for the port.</p> <p>To prevent voice channels from generating occasional noise bursts caused by unsynchronized nodes, we recommend that you configure one end of the voice port (not both) for adaptive clocking or lock both ends to clock references.</p>	<p>Select one:</p> <ul style="list-style-type: none"> <li>• 4WTO/IRIG - Master End—This end of the circuit generates a clock signal and sends it to the remote end.</li> <li>• 4WTO/IRIG - Adaptive End— This end of the circuit receives the clock signal from the remote end. The client clock uses its period to determine when to sample data and how to transmit data across the link.</li> <li>• Custom—The custom clocking configuration is used.</li> </ul>

## RELATED DOCUMENTATION

Configuring Multiservice 4WTO Mode Port Parameters for CTP Bundles (CTP Menu) | 87

## Configuring IRIG-B Port Parameters for CTP Bundles (CTP Menu)

This topic describes how to configure port parameters for IRIG-B daughter cards.

Adaptive clocking is configured by default on IRIG-B bundles, and the packet size is set to 64 bytes. The packet size combined with the default data rate of 16 Kbps produces a packet rate of 32 pps, which is a good packet rate for adaptive clocking.

Before you begin:

- Disable the bundle before you modify the bundle options.

To configure IRIG-B port parameters using the CTP Menu:

1. From the CTP Main Menu, select **1) Bundle Operations**.
2. Select **1) CTP**.
3. Select a bundle from the list. The bundle port must have an IRIG-B daughter card installed.  
If you select an active bundle, you are prompted to disable the bundle before configuring it.
4. Select **3) Port Config**.
5. Select **2) Interface**.
6. Select **1) Type** and set the type to **Optional Interface: IRIG-B**.
7. Follow the onscreen instructions and configure the options as described in [Table 26 on page 95](#).  
The options vary depending on whether the bundle is T1 or E1 and whether fractional T1 or E1 is configured.
8. To configure clocking for the port, select **3) Clock Config** and configure the Clock Config option as described in [Table 26 on page 95](#).

Table 26: CTP Bundle IRIG-B Port Parameter Settings in the CTP Menu

Field	Function	Your Action
Direction	<p>Specifies the direction of the circuit. Although the IP circuit connection through the network is full duplex, an IRIG-B circuit is actually a simplex application, and the daughter card can operate only in Rx or Tx mode and not both at the same time.</p> <p>If the autonegotiation setting of the CTP Ethernet media and the far-end switch or router do not match, it is possible for the CTP Ethernet ports to be in a half-duplex state, although the duplex setting is not configurable and always assumed to be full-duplex on the CTP device. Starting with CTPOS Release 7.2, the half-duplex state at CTP network interface card (NIC) ports are acquired, regardless of the duplex setting configured on the far-end node. After the autonegotiation process is completed, if the CTP NIC cannot acquire full-duplex mode, then the interfaces are considered to be down and a log message is recorded in both the <code>/var/log/messages</code> directory and the syslog file stating that the interface is down due to a non-full duplex condition. You are prompted to verify the cable connection, speed, and duplex settings because the NIC link might be down.</p>	<p>Specify yes or no to the question: Is this an IRIG-B source end (IRIB-B signal enters CTP)?</p> <ul style="list-style-type: none"> <li>• Yes (y)—Sets direction to Rx. This end of the circuit recovers IRIG-B from the attached cable and generates IP packets toward the network</li> <li>• No (n)—Sets the direction to Tx. This end of the circuit accepts IP packets, extracts the IRIG-B data codes, and transmits IRIG-B signaling output onto the cable.</li> </ul>

Table 26: CTP Bundle IRIG-B Port Parameter Settings in the CTP Menu (*Continued*)

Field	Function	Your Action
Output High Level	<p>This setting appears only if you set the direction of the port to Tx.</p> <p>Specifies the high output level, which is measured in peak-to-peak voltage. This setting is based on a 50-ohm termination</p>	Enter a number from 0.00 through 7.85 volts peak-to-peak.
Output Low Volts Level	<p>This setting appears only if you set the direction of the port to Tx.</p> <p>Specifies the low output level, which is measured in peak-to-peak voltage. This setting is based on a 50-ohm termination.</p>	Enter a number from 0.00 through 7.85 volts peak-to-peak.
Port Speed (kbps)	<p>Specifies the data rate on the IP connection.</p> <p>Unless network bandwidth is at a premium, we do not recommend that you change this value from the default of 16 Kbps.</p>	Enter a number from 1000 through 25,500 bps. The port speed must be a multiple of 100 bps.
Clock Config	Specifies the type of clocking for the bundle.	<p>Select one:</p> <ul style="list-style-type: none"> <li>● 4WTO/IRIG - Master End—This end of the circuit generates a clock signal and sends it to the remote end.</li> <li>● 4WTO/IRIG - Adaptive End— This end of the circuit receives the clock signal from the remote end. The client clock uses its period to determine when to sample data and how to transmit data across the link.</li> <li>● Custom—The custom clocking configuration is used.</li> </ul>



## Configuring Advanced Port Options for CTP Bundles (CTP Menu)

Before you begin:

- Disable the bundle before you modify the bundle options.

To configure advanced port options for CTP bundles using the CTP Menu:

1. From the CTP Main Menu, select **1) Bundle Operations**.
2. Select **1) CTP**.
3. Select a bundle from the list.

If you select an active bundle, you are prompted to disable the bundle before configuring it.

4. Select **3) Port Config**.
5. Select **4) Advanced Options**.
6. Configure the options as described in [Table 27 on page 97](#).

**Table 27: CTP Bundle Advanced Port Option Settings in the CTP Menu**

Field	Function	Your Action
Single ended data/clock outputs	Do not change this value without consulting JTAC.  Specifies whether or not the CTP device drives received data (RD) onto data set ready (DSR) and real-time (RT) data onto test mode (TM).	Select y or n.
Reclock RD to align RD/RT	Do not change this value without consulting JTAC.  Specifies whether or not to reclock RD with the RT clock to align the data and the clock.	Select y or n.

Table 27: CTP Bundle Advanced Port Option Settings in the CTP Menu *(Continued)*

Field	Function	Your Action
Only high TT checking	<p>Specifies that the CTP device disqualifies transmit timing (TT) only when it is higher than the port speed.</p> <p>When enabled, this setting keeps the port from going to the TtFail state when the incoming user clock fluctuates between 0 and the configured port rate. If the TT rate goes above the configured port rate, the CTP device sends the port to the TtFail state to protect the system from an overspeed TT, which would cause problems for the port, CTP device, or network.</p>	Select y or n.
TT Clock Gated by RTS	When request to send (RTS) is inactive, specifies whether or not the CTP device feeds TT with the internally created clock.	Select y or n.
RTS Clock Gate Invert	When clock gating is enabled, specifies whether or not to use the inverted RTS signal.	Select y or n.
Input/Output Data Invert	Specifies whether or not to invert data bound for the interface with data bound for the IP network.	Select y or n.
Substitute DDS when TT gone	Helps maintain the low-speed port on a TDM/TDC CTP serial circuit at up when the high-speed circuit goes down.	Select y or n.

Table 27: CTP Bundle Advanced Port Option Settings in the CTP Menu (*Continued*)

Field	Function	Your Action
SD activity for RTS	<p>Specifies whether to replace the incoming RTS indicator with the state of the incoming send data (SD) activity monitor.</p> <p>When disabled, the logic value of incoming RTS signal determines the state of the RTS indicator. When enabled, the presence (or absence) of incoming data transitions determines the state of the RTS indicator. This capability allows SD activity to be used to determine the state of demand CTP bundles.</p>	Select y or n.

## Selecting the Type of Clocking on Serial Ports for CTP Bundles (CTP Menu)

This topic describes how to select the type of clocking that you want to use on serial ports. The type of clocking supported depends on the type of encoding you are using.

Before you begin:

- Disable the bundle before you modify the bundle options.

CTP Menu gives you the option of selecting the clocking type when you change the interface encoding for a circuit. You can also specify the clocking type for CTP bundles using the CTP Menu as follows:

1. From the CTP Main Menu, select **1) Bundle Operations**.
2. Select **1) CTP**.
3. Select a bundle from the list.

If you select an active bundle, you are prompted to disable the bundle before configuring it.

4. Select **3) Port Config**.
5. Select **3) Clock Config**.
6. Select **1) Port Clock Config**.
7. Configure the options as described in [Table 28 on page 100](#).

Table 28: Clocking Type Supported for Each Encoding Type as Displayed in the CTP Menu

Encoding Type	Clocking Type Supported
NRZ and TDM with interface mode set to DCE	<p>You can specify the following clocking methods for NRZ and TDM circuits with DCE mode specified:</p> <ul style="list-style-type: none"> <li>• Custom—The custom clocking configuration is used.</li> <li>• Configured Rate, w/o Ext Tx Clk (TT)—Configured rate without external TX clock (TT). The CTP device synthesizes the rate that is used on the ST and RT outputs to the attached device. The ST is used to sample Send Data from the attached DTE. The clock is created by the CTP DDS circuitry and logic. This option is commonly used on circuits that are less than 1 Mbps.</li> <li>• Configured Rate, Ext Tx Clk (TT)—Configured rate with external TX clock (TT). The CTP device synthesizes the rate that is used on the ST and RT outputs to the attached device. The clock is created by the DDS circuitry and logic. This option is used to sample Send Data from the attached device. It assumes that the attached device is using ST or clock reference that is traceable to CTP reference. It is typically used for higher data rates (&gt;1 Mbps) and long cables.</li> <li>• All Clocked by Ext Tx Clk (TT)—All clocked with external TX clock (TT). The CTP device uses the external TT timing from the DTE for all clocking. Ext TT is used to sample Send Data from the attached device, to generate the RT clock, and to clock data into the IP network.</li> <li>• Adaptive Rate, Ext Tx Clk (TT)—Adaptive clocking with external TX clock (TT).</li> <li>• Adaptive Rate, w/o Ext Tx Clk (TT)—Adaptive clocking with internal clock.</li> <li>• Autobaud Rate, Ext Tx Clk (TT)—Autobaud rate with internal clock.</li> <li>• Autobaud Rate, w/o Ext Tx Clk (TT)—Autobaud rate with external clock.</li> <li>• TDM/TDC Interleaved Slow Port—Available only on odd-numbered ports. Use this option for the low-speed port of a time domain correlation (TDC) circuit.</li> </ul>

Table 28: Clocking Type Supported for Each Encoding Type as Displayed in the CTP Menu *(Continued)*

Encoding Type	Clocking Type Supported
NRZ and TDM with interface mode set to DTE	<p>You can specify the following clocking methods for NRZ and TDM circuits with DTE mode specified:</p> <ul style="list-style-type: none"> <li>• Adaptive Rate, Ext Tx Clk (TT)—Adaptive clocking with external TX clock (TT).</li> <li>• Adaptive Rate, w/o Ext Tx Clk (TT)—Adaptive clocking with internal clock.</li> <li>• Autobaud Rate, Ext Tx Clk (TT)—Autobaud rate with internal clock.</li> <li>• Autobaud Rate, w/o Ext Tx Clk (TT)—Autobaud rate with external clock.</li> <li>• DTE, All Clocked by Ext Clk (ST/RT)—The DCE equipment provides all clocks. The ST input clock is used to clock out the external transmit clock (TT) and the send data (SD). The RT input clock is used to clock in the receive data (RD).</li> <li>• TDM/TDC Interleaved Slow Port—Available only on even-numbered bundles. Use this option for the slower port of the time domain correlation (TDC) circuit.</li> <li>• DTE, All Clocked by User Clk(RT)—The DCE equipment provides all clocks. The RT input clock is used to clock out the external transmit clock (TT) and the send data (SD) and to clock in the receive data (RD).</li> <li>• Custom—The custom clocking configuration is used.</li> </ul>

Table 28: Clocking Type Supported for Each Encoding Type as Displayed in the CTP Menu *(Continued)*

Encoding Type	Clocking Type Supported
ISOCH	<p>You can specify the following clocking methods for ISOCH circuits:</p> <ul style="list-style-type: none"> <li>• Adaptive Rate, Ext Tx Clk (TT)—Adaptive clocking with external TX clock (TT).</li> <li>• Adaptive Rate, w/o Ext Tx Clk (TT)—Adaptive clocking with internal clock.</li> <li>• Autobaud Rate, Ext Tx Clk (TT)—Autobaud rate with internal clock.</li> <li>• Autobaud Rate, w/o Ext Tx Clk (TT)—Autobaud rate with external clock.</li> <li>• ISOCH - Master End—This end of the circuit generates a clock signal and sends it to the remote end. Configure <b>ISOCH - Adaptive End</b> at the remote end.</li> <li>• ISOCH - Adaptive End—This end of the circuit uses adaptive clocking to receive the clock signal from the remote end. The client clock uses its period to determine when to sample data and how to transmit data across the link.</li> <li>• Custom—The custom clocking configuration is used.</li> </ul>
CDI	<p>You can specify the following clocking methods for CDI circuits:</p> <ul style="list-style-type: none"> <li>• Adaptive Rate, Ext Tx Clk (TT)—Adaptive clocking with external TX clock (TT).</li> <li>• Adaptive Rate, w/o Ext Tx Clk (TT)—Adaptive clocking with internal clock.</li> <li>• Autobaud Rate, Ext Tx Clk (TT)—Autobaud rate with internal clock.</li> <li>• Autobaud Rate, w/o Ext Tx Clk (TT)—Autobaud rate with external clock.</li> <li>• CDI - Master End—This end of the circuit generates a clock signal and sends it to the remote end. Configure <b>CDI - Adaptive End</b> at the remote end.</li> <li>• CDI - Adaptive End—This end of the circuit uses adaptive clocking to receive the clock signal from the remote end. The client clock uses its period to determine when to sample data and how to transmit data across the link.</li> <li>• Custom—The custom clocking configuration is used.</li> </ul>

Table 28: Clocking Type Supported for Each Encoding Type as Displayed in the CTP Menu (*Continued*)

Encoding Type	Clocking Type Supported
TRANS	<p>You can specify the following clocking methods for TRANS circuits:</p> <ul style="list-style-type: none"> <li>• Adaptive Rate, Ext Tx Clk (TT)—Adaptive clocking with external TX clock (TT).</li> <li>• Adaptive Rate, w/o Ext Tx Clk (TT)—Adaptive clocking with internal clock.</li> <li>• Autobaud Rate, Ext Tx Clk (TT)—Autobaud rate with internal clock.</li> <li>• Autobaud Rate, w/o Ext Tx Clk (TT)—Autobaud rate with external clock.</li> <li>• TRANS - Master End—This end of the circuit generates a clock signal and sends it to the remote end. Configure <b>TRANS - Adaptive End</b> at the remote end.</li> <li>• TRANS - Adaptive End—This end of the circuit uses adaptive clocking to receive the clock signal from the remote end. The client clock uses its period to determine when to sample data and how to transmit data across the link.</li> <li>• Custom—The custom clocking configuration is used.</li> </ul>

## Configuring Custom Clocking for CTP Bundles (CTP Menu)

The custom clocking configuration allows you to configure the source for all clocks and specify which clocks are used to sample and transmit data. The configuration provides complete control over how clocks are used, and we recommend that you have a good understanding of circuit and system clocking before you use this configuration.

You can use custom clocking to:

- Configure the interface to use nonstandard clock configurations that meet the timing needs of your application.
- Configure asymmetric clocks.
- Create special configurations for devices such as tactical radios.

Before you begin:

- Disable the bundle before you modify the bundle options.

To configure custom clocking for CTP bundles using the CTP Menu:

1. From the CTP Main Menu, select **1) Bundle Operations**.
2. Select **1) CTP**.
3. Select a bundle from the list.  
If you select an active bundle, you are prompted to disable the bundle before configuring it.
4. Select **3) Port Config**.
5. Select **3) Clock Config**.
6. Select **1) Port Clock Config**.
7. Select **Custom**.
8. Configure the options as described in [Table 29 on page 104](#).

**Table 29: CTP Bundle Custom Clocking Settings in the CTP Menu**

Field	Function	Your Action
DDS Synthesizer Source	Specifies the clock source for the DDS.	Select: <ul style="list-style-type: none"> <li>• User (OI)—The clock is recovered from the user equipment.</li> <li>• Adaptive—The DDS uses adaptive clocking to recover the clock signal from the remote CTP device.</li> <li>• Autobaud—This setting enables the monitoring of OAM packets for the terminal timing (TT) frequency at the other end and processing to accommodate frequency changes that are detected.</li> </ul>



Table 29: CTP Bundle Custom Clocking Settings in the CTP Menu *(Continued)*

Field	Function	Your Action
DIV (clk divider) Source	<p>Specifies the source for the divider clock. The DIV clock is an alternative clock generator for the bundle, and its output clock is an even integer divider of its source clock.</p> <p>The divider is used to configure asymmetric circuits.</p> <p>For example, if the source clock is 512 KHz, the output of the DIV clock can be 256 KHz, 128 KHz, 85.333 KHz, so on.</p>	<p>Select:</p> <ul style="list-style-type: none"> <li>• DDS Output—Direct digital synthesizer clock generator.</li> <li>• Oscillator—Oscillator system clock.</li> </ul>
DIV (clk divider) Value	<p>Specifies the divider clock value. The clock value of the DIV source is divided by this value to obtain the output clock value of the DIV clock.</p>	<p>Enter an even number from 2 through 64,000.</p>

Table 29: CTP Bundle Custom Clocking Settings in the CTP Menu *(Continued)*

Field	Function	Your Action
ST (net bound i/f) clk sel	Specifies the clock used for Send Timing on the network bound interface.	<p>Select one (the values that appear depend on whether the bundle is configured as the DCE or as the DTE):</p> <ul style="list-style-type: none"> <li>• OFF—No clock is used.</li> <li>• ST (ext clk)—Send timing clock. The interface clock signal from the DCE to the DTE (CTP device).</li> <li>• DDS (synth)—Direct digital synthesizer clock</li> <li>• TT (ext clk)—Transmit timing clock. The interface clock signal from the DTE to the DCE (CTP device).</li> <li>• RT (ext clk)—Receive timing clock. Interface clock signal from the DCE to the DTE (CTP device).</li> <li>• DIV (synth)—Divider clock generator.</li> </ul>

Table 29: CTP Bundle Custom Clocking Settings in the CTP Menu *(Continued)*

Field	Function	Your Action
RF (net bound fifo) clk sel	Specifies the clock used for Receive Frequency on the network bound interface.	<p>Select one (the values that appear depend on whether the bundle is configured as the DCE or as the DTE):</p> <ul style="list-style-type: none"> <li>• OFF—No clock is used.</li> <li>• ST (ext clk)—Send timing clock. The interface clock signal from the DCE to the DTE (CTP device).</li> <li>• DDS (synth)—Direct digital synthesizer clock</li> <li>• TT (ext clk)—Transmit timing clock. The interface clock signal from the DTE to the DCE (CTP device).</li> <li>• RT (ext clk)—Receive timing clock. Interface clock signal from the DCE to the DTE (CTP device).</li> <li>• DIV (synth)—Divider clock generator.</li> </ul>

Table 29: CTP Bundle Custom Clocking Settings in the CTP Menu (*Continued*)

Field	Function	Your Action
RX (net bound scc) clk sel	Specifies the clock used for the Receive Data path on the network bound serial communications controller (SCC).	<p>Select one (the values that appear depend on whether the bundle is configured as the DCE or as the DTE):</p> <ul style="list-style-type: none"> <li>• OFF—No clock is used.</li> <li>• ST (ext clk)—Send timing clock. The interface clock signal from the DCE to the DTE (CTP device).</li> <li>• DDS (synth)—Direct digital synthesizer clock</li> <li>• TT (ext clk)—Transmit timing clock. The interface clock signal from the DTE to the DCE (CTP device).</li> <li>• RT (ext clk)—Receive timing clock. Interface clock signal from the DCE to the DTE (CTP device).</li> <li>• DIV (synth)—Divider clock generator.</li> </ul>
RT (i/f bound i/f) clk sel	<p>Specifies the clock used for Receive Timing on the interface bound interface.</p> <p>This parameter appears only if you have configured the bundle as the DCE.</p>	<p>Select one:</p> <ul style="list-style-type: none"> <li>• OFF—No clock is used.</li> <li>• DDS (synth)—Direct digital synthesizer clock</li> <li>• TT (ext clk)—Transmit timing clock. The interface clock signal from the DTE to the DCE (CTP device).</li> <li>• DIV (synth)—Divider clock generator.</li> </ul>

Table 29: CTP Bundle Custom Clocking Settings in the CTP Menu *(Continued)*

Field	Function	Your Action
TT (i/f bound i/f) clk sel	<p>Specifies the Transmit Timing clock on the interface bound interface.</p> <p>This parameter appears only if you have configured the bundle as the DTE.</p>	<p>Select one:</p> <ul style="list-style-type: none"> <li>• ST (ext clk)—Send timing clock. The interface clock signal from the DCE to the DTE (CTP device).</li> <li>• DDS (synth)—Direct digital synthesizer clock</li> <li>• RT (ext clk)—Receive timing clock. Interface clock signal from the DCE to the DTE (CTP device).</li> <li>• DIV (synth)—Divider clock generator.</li> </ul>

Table 29: CTP Bundle Custom Clocking Settings in the CTP Menu (*Continued*)

Field	Function	Your Action
TX (i/f bound scc) clk sel	Specifies the clock used for the Transmit Data path on the interface bound serial communications controller (SCC).	<p>Select one (the values that appear depend on whether the bundle is configured as the DCE or as the DTE):</p> <ul style="list-style-type: none"> <li>• OFF—No clock is used.</li> <li>• ST (ext clk)—Send timing clock. The interface clock signal from the DCE to the DTE (CTP device).</li> <li>• DDS (synth)—Direct digital synthesizer clock</li> <li>• TT (ext clk)—Transmit timing clock. The interface clock signal from the DTE to the DCE (CTP device).</li> <li>• RT (ext clk)—Receive timing clock. Interface clock signal from the DCE to the DTE (CTP device).</li> <li>• DIV (synth)—Divider clock generator.</li> </ul>

## Configuring Adaptive Clocking for CTP Bundles (CTP Menu)

The adaptive clocking configuration allows you to modify attributes that affect the adaptive clocking algorithm. The default settings are acceptable for most applications. We recommend that you change these settings only with the assistance of JTAC.

Before you begin:

- Disable the bundle before you modify the bundle options.

To configure adaptive clocking for CTP bundles using the CTP Menu:

1. From the CTP Main Menu, select **1) Bundle Operations**.

2. Select **1) CTP**.

3. Select a bundle from the list.

If you select an active bundle, you are prompted to disable the bundle before configuring it.

4. Select **3) Port Config**.

5. Select **3) Clock Config**.

6. Select **1) Port Clock Config**.

7. Select **Set Adaptive Parameters**.

8. Configure the options as described in [Table 30 on page 111](#).

**Table 30: CTP Bundle Adaptive Clocking Settings in the CTP Menu**

Field	Function	Your Action
Set to Defaults	Sets the adaptive clocking configuration to the default settings.	Select <b>Set to Defaults</b> .
AGGR Seconds/Calc	Specifies the time period during initial start of adaptive clocking during which packet samples that are experiencing the least delay through the network are collected. These samples are used for aggressive state calculations.	Enter a number from 3 through 200 seconds.
MNTN Seconds/Calc	Specifies the time period during normal adaptive clocking during which packet samples that are experiencing the least delay through the network are collected. These samples are used for maintenance state calculations.	Enter a number from 3 through 300 seconds.

Table 30: CTP Bundle Adaptive Clocking Settings in the CTP Menu *(Continued)*

Field	Function	Your Action
Slope for MNTN in ppm	Specifies the number of packets per minute, which when reached, causes the adaptive clocking algorithm to change from aggressive state to maintenance state. Lower values result in longer switchover times with a clock value closer to the remote clock.	Enter a number from 1 through 100 packets per minute.
Maintenance Decay in calcs	Specifies how quickly the clocking corrects to the buffer set point while in maintenance state.	Enter a number from 2 through 120 seconds.
Max Clock Adjust in ppb	Specifies a cap for frequency acceleration, which constrains the frequency adjustments to the adaptive clock.	Enter a number from 1 through 1000 parts per billion.
Max Clock Offset in ppm	Specifies a cap for frequency velocity, which constrains the frequency velocity of the adaptive clock.	Enter a number from 1 through 400 packets per minute.
Max Buffer Error in usec	Specifies the buffer error rate required to change the adaptive clocking algorithm state from maintenance to aggressive.	Enter a number from 100 through 1,000,000 $\mu$ seconds.

## RELATED DOCUMENTATION

[Adaptive Clocking Overview for CTP Bundles](#) | 7



## Configuring Ethernet Media (CTP Menu)

You can configure the CTP Ethernet media to autonegotiate the duplex mode and speed and to set the speed to either 100 or 10 Mbps. The Ethernet configurations on the CTP device must match the configuration of the connected router or switch. Mismatched configurations, such as setting the CTP system to autonegotiate and the router to full duplex, may result in a misconfiguration and dropped packets. You must disable Cisco Discovery Protocol on the Fast Ethernet port connected to the CTP system.

To configure Ethernet interfaces on a CTP device using the CTP Menu:

1. From the Main Menu, select **5) Node Operations**.
2. Display the current Ethernet configuration by selecting **12) Config ethernet media**.

```

***
*** You are about to modify a system parameter that will require
*** a system reboot when complete.
***
*** If you decide to continue, the system will automatically
*** reboot upon leaving these menus.
***
*** Note: If these parameters are changed incorrectly,
***     system may not be reachable via the network
***     after the system reboots.
***
    Are you sure? y[n]: y
Here is a list of the available ethernet devices and their descriptions:
    eth0: 10/100/1000 Copper (right)
    eth1: 10/100/1000 Copper (left)
Please input the device to configure the media for: eth0

Configure eth0 (e1000) for autonegotiation? [y] n

Configure eth0 for 100 Mbps [y] n
OK, setting speed to 10 Mbps.
```

Autonegotiation is enabled by default and the speed is set to 1000 Mbps

Field	Function	Your Action
Please input the device to configure the media for	Specifies the Ethernet port	Specify an Ethernet port from the list.
Configure eth0 (e1000) for autonegotiation	Specifies whether autonegotiation is enabled. The default speed for autonegotiation is 1000 Mbps.	Specify y or n.  If you specify y, autonegotiation is enabled and the speed is set to 1000 Mbps.  If you specify n, the system prompts you to set the speed to 100 Mbps.
Configure eth0 for 100 Mbps	Specifies the speed. This field is not displayed if autonegotiation is enabled.	Specify y or n. If you specify y, the system sets the speed to 100 Mbps.  If you specify n, the speed is set to 10 Mbps.

### 3. Specify the Ethernet device you want to configure, and follow the onscreen instructions.

If the autonegotiation setting of the CTP Ethernet media and the far-end switch or router do not match, it is possible for the CTP Ethernet ports to be in a half-duplex state, although the duplex setting is not configurable and always assumed to be full-duplex on the CTP device. Starting with CTPOS and CTPView Release 7.2, the half-duplex state at CTP network interface card (NIC) ports are acquired, regardless of the duplex setting configured on the far-end node. After the autonegotiation process is completed, if the CTP NIC cannot acquire full-duplex mode, then the interfaces are considered to be down and a log message is recorded in both the `/var/log/messages` directory and the syslog file stating that the interface is down due to a non-full duplex condition. You are prompted to verify the cable connection, speed, and duplex settings because the NIC link might be down.

## RELATED DOCUMENTATION

[Ethernet Media Configuration Overview | 37](#)

[Displaying Ethernet Media Information \(CTP Menu\) | 115](#)

## Displaying Ethernet Media Information (CTP Menu)

This topic describes how to display the supported link modes (speed and duplex) and the configuration of the Ethernet media on CTP devices.

To display Ethernet interface information on a CTP device using the CTP Menu:

1. From the Main Menu, select **5) Node Operations**.
2. Display the current Ethernet configuration by selecting **11) Display ethernet media**.

A list a of available Ethernet devices and is displayed.

3. Specify the Ethernet device whose details are to be displayed.

The CTP system displays the details of the Ethernet device that you selected.

If the autonegotiation setting of the CTP Ethernet media and the far-end switch or router do not match, it is possible for the CTP Ethernet ports to be in a half-duplex state, although the duplex setting is not configurable and always assumed to be full-duplex on the CTP device. Starting with CTPOS Release 7.2, the half-duplex state at CTP network interface card (NIC) ports are acquired, regardless of the duplex setting configured on the far-end node. After the autonegotiation process is completed, if the CTP NIC cannot acquire full-duplex mode, then the interfaces are considered to be down and a log message is recorded in both the `/var/log/messages` directory and the syslog file stating that the interface is down due to a non-full duplex condition. You are prompted to verify the cable connection, speed, and duplex settings because the NIC link might be down.

### RELATED DOCUMENTATION

[Ethernet Media Configuration Overview | 37](#)

[Configuring Ethernet Media \(CTP Menu\) | 113](#)

## Configuring PBS and Bridge Ports (CTP Menu)

Configuring a packet-bearing serial (PBS) interface allows you to connect a CTP device to an IP network through a serial interface. A port configured as a PBS interface uses static routes and does not participate in any routed protocol sessions, such as OSPF and RIP.

A port must be configured as either a circuit emulation port or a PBS interface or as a bridge port. The default is the circuit emulation port. You can change the port between circuit emulation and PBS modes from the **Node Operations** menu. You can configure PBS interface or bridge ports from the CTPView web interface or from the CTP menu. This section describes how to configure PBS from the CTP Menu.

If any port on a CTP node is configured as a PBS or bridge port, then the Direct Drive option is automatically set to Disabled on all bundles on that node. If a port is configured as a PBS or bridge port, then all the bundles on that port is deleted. If a bundle is created on a different port, the Direct Drive option is disabled on that port when other ports are configured as a PBS or bridge port.

**NOTE:** Only users with administrative privileges can configure PBS.

To configure a PBS interface from CTP menu:

1. From the Main Menu, select **5) Node Operations**.
2. Select **3) Configure network settings > 11) Config port operational mode (CE/PBS/bridge)**.
3. Select the port that you want to configure for PBS.
4. Select **1) Routed (PBS)**  
The CTP system restarts after you select the port.
5. Select **5) Node Operations > 10) Port operations (PBS/bridge)**.
6. When prompted, specify the port that you want to configure as a PBS interface.

```
Please choose from the following PBS/bridge ports:
se-2/7
Enter Port [se-2/7 ]:
```

7. Select **2) Config**.
8. Specify the options as described in [Table 31 on page 116](#).

**Table 31: Configuration Options for a PBS Port**

Field	Function	Your Action
Port description	Specifies a description for the port.	Enter a description of up to 64 alphanumeric characters. Use only the following special characters:  _ + @ : , . -
Encapsulation	PPP and HDLC encapsulation are supported by PBS interfaces. Select the encapsulation from the CLI or from the CTPView drop-down menu.	Select one: <ul style="list-style-type: none"> <li>• CHDLC</li> <li>• PPP</li> </ul>

Table 31: Configuration Options for a PBS Port *(Continued)*

Field	Function	Your Action
Local Address of P2P Link	The PBS interface requires that the IP address of the local IP interfaces be specified.	Enter the IP address of the local IP interface.
Remote ip of p2p link	<p>The PBS interface requires that the IP address of the remote IP interfaces be specified.</p> <p>Both the local and the remote IP interfaces must be on the same network.</p>	Enter the IP address of the remote IP interface.

Table 31: Configuration Options for a PBS Port *(Continued)*

Field	Function	Your Action
Clock Config	<p>The clock configuration submenu lets you configure port speed and clock configuration. The clocking options include configured rate with and without external TT, all clocked by external TT, and custom clocking.</p> <p>CTPView allows you to configure the rate using an input field and to specify the clocking from a drop-down menu of valid options.</p>	<p>Select one:</p> <ul style="list-style-type: none"> <li>• Cfg Rate - Int Clk—Configured rate without external TX clock (TT). The CTP device synthesizes the rate that is used on the ST and RT outputs to the attached device. The ST output is used to sample Send Data from the attached DTE. The clock is created by the CTP DDS circuitry and logic. This option is commonly used on circuits that are less than 1 Mbps.</li> <li>• Cfg Rate - Ext Clk—Configured rate with external TX clock (TT). The CTP device synthesizes the rate that is used on the ST and RT outputs to the attached device. The clock is created by the DDS circuitry and logic. This option is used to sample Send Data from the attached device. It assumes that the attached device is using an ST or a clock reference that is traceable to CTP reference. It is typically used for higher data rates (&gt;1 Mbps) and long cables.</li> <li>• All Clock - Ext Clk—All clocked with external TX clock (TT). The CTP clock uses the external TT timing from the DTE for all clocking. Ext TT is used to sample Send Data from the attached device, to generate the RT clock, and to clock data into the IP network.</li> <li>• Custom—The custom clocking configuration is used.</li> </ul>

Table 31: Configuration Options for a PBS Port *(Continued)*

Field	Function	Your Action
Interface	The Interface is configurable to be either EIA530, EIA530A, RS232, V.35, or T1/E1 (optional when hardware is installed). The encoding is limited to NRZ.	Select one: <ul style="list-style-type: none"> <li>• EIA530</li> <li>• EIA530A</li> <li>• RS232</li> <li>• V.35</li> <li>• T1/E1</li> </ul>
MTU	The MTU can be configured to a value up to 1500 bytes. MTU fragmentation is not supported.	Enter the MTU in bytes. The default value is 1500.
First static route	You can configure up to three active static routes that use the PBS interface. The static routes must not conflict with the static routes configured on any other PBS Interfaces.	Enter up to three static routes.
Second static route		
Third static route		

9. Select **3) Activate** to activate the port that you configured as PBS.

## RELATED DOCUMENTATION

[Configuring PBS and Bridge Ports \(CTPView\) | 206](#)

[Monitoring PBS and Bridge Ports Configuration from CTPView](#)

## Configuring Port Mirroring for CTP Bundles (CTP Menu)

Port mirroring enables carrying the data on a unidirectional bundle (or one direction of a bidirectional bundle), replicating it, and sending it to an additional port (that is, a port mirroring tail). The data replication may happen at the source (CTP on which the data enters the IP network) or destination (CTP

on which the data exits the IP network). Tails are actually unidirectional source bundles associated with the CTP bundle, which need to be terminated on a unidirectional destination bundle.

You can configure a maximum of 25 tails for each port mirroring type (source and destination), and the entire CTP bundle can have a maximum of 50 tails (25 source tails and 25 destination tails). See [Figure 13 on page 120](#) for the allowed port mirroring configurations.

Bundles that use port mirroring must have the direct drive disabled. When a bundle configuration that has a port mirroring component is submitted, the CTPView software enforces the direct drive rule when the node is configured to the new settings.

**Figure 13: Allowed Port Mirroring Configurations**

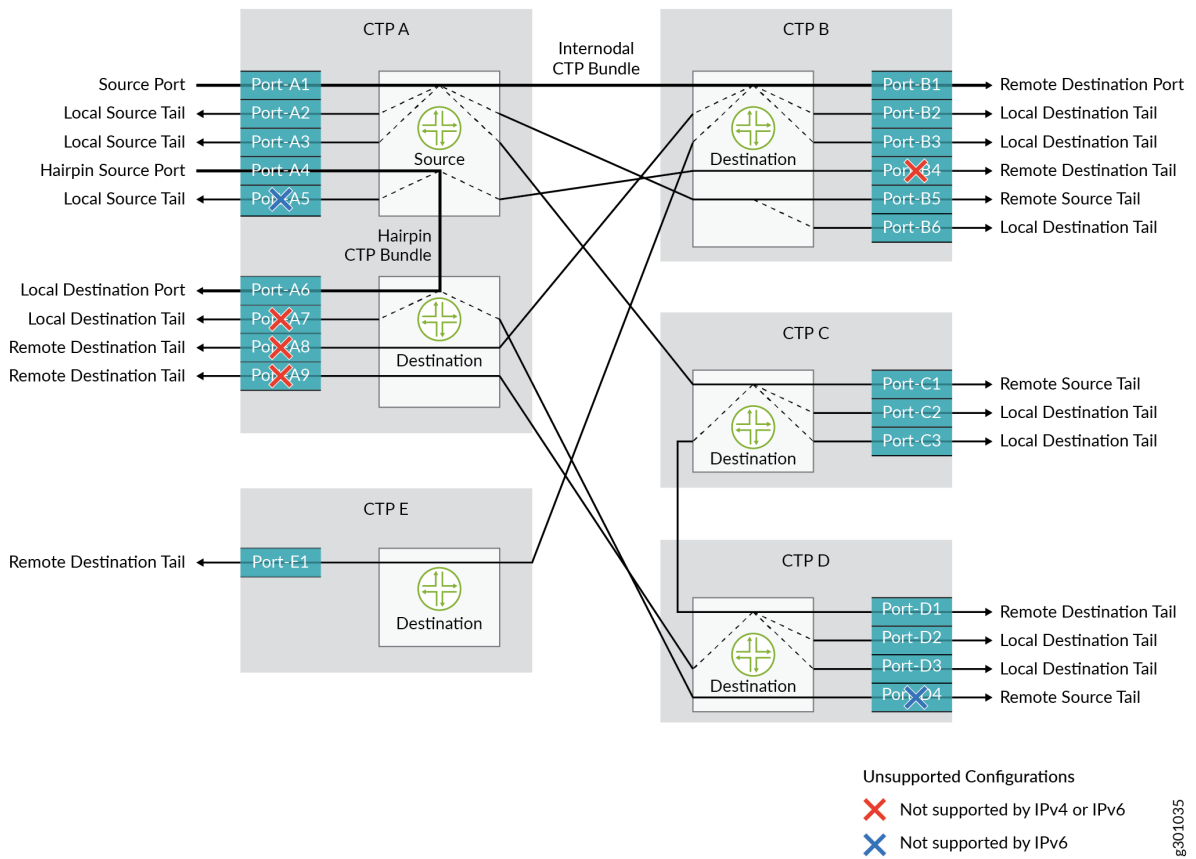

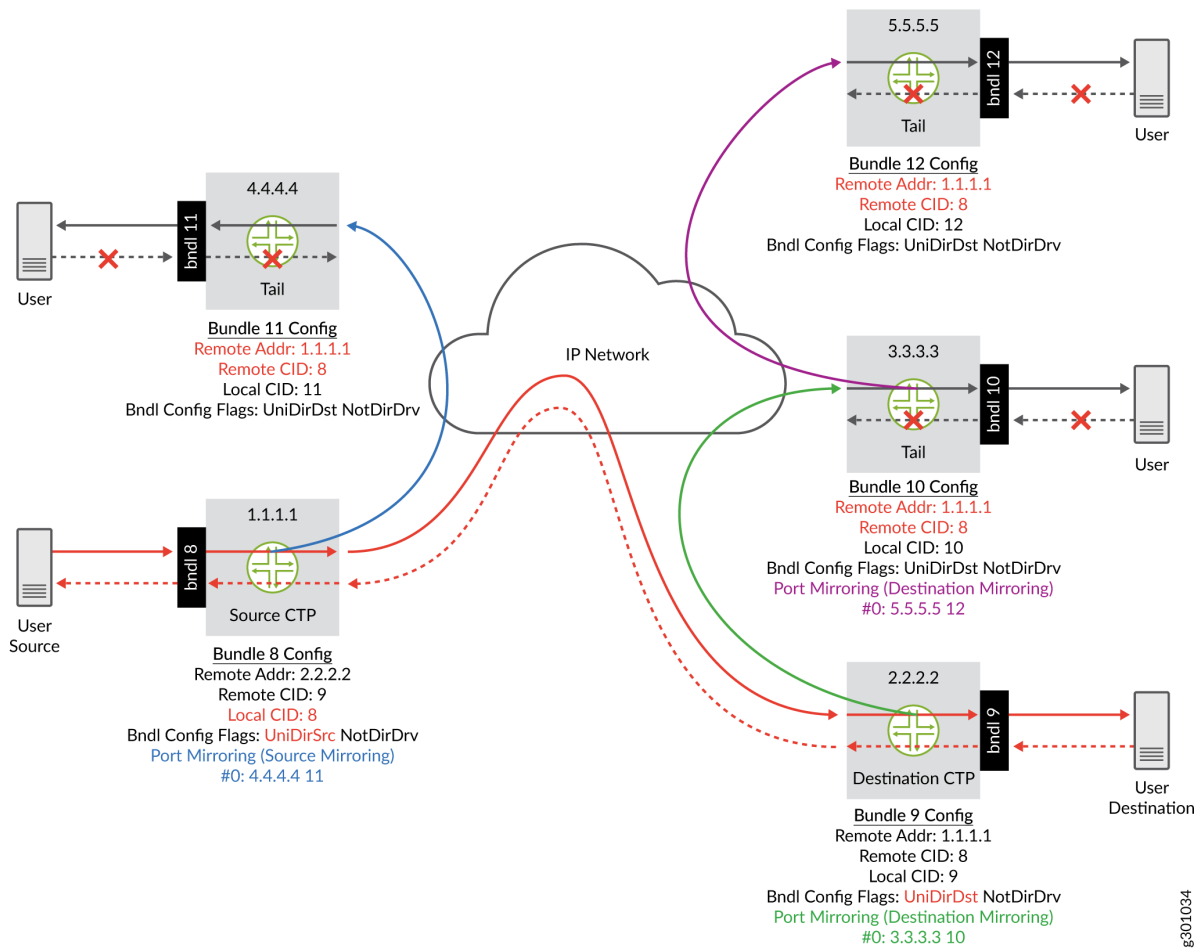

**Table 32: Port Names and Descriptions**

Port Name	Description
CTP Bundle	The CTP bundle from which mirrored ports are created.
Source Port	The source of user data, and the source port for the CTP bundle. The source port can be either unidirectional or full-duplex.
Remote Destination Port	Destination port (remote from the source port) for the CTP bundle, carrying user data.
Local Destination Port	Destination port (local to source port, that is, hairpin) for the CTP bundle, carrying user data.
Local Source Tail	Mirrored port from the source side of CTP bundle, terminating on the same node as source tail point.
Remote Source Tail	Mirrored port from source side of CTP bundle, terminating on a different node from the source tail point.
Local Destination Tail	Mirrored port from destination side of any (CTP or remote source/destination tail) bundle, terminating on the same node as the tail point.
Remote Destination Tail	Mirrored port from destination side of any (CTP or remote source/destination tail) bundle, terminating on a different node as the tail point.  <b>NOTE:</b> A remote destination tail port that terminates on the CTP bundle source side is not allowed.

Destination tails need to be configured to point back to the source port of the CTP bundle. See [Figure 14 on page 122](#) for an example port mirroring configuration.

Figure 14: Example Port Mirroring Configuration



**NOTE:** To view and configure port mirroring parameters, you must login as an administrator.

**NOTE:** You cannot configure the destination port mirroring tail with a remote IP address that is the same as the IP address of the Source CTP.

**NOTE:** For serial ports, the default port speed of a bundle is set to 1024 KHz. If you are configuring more than 11 source or destination tails on a single node, the bundle goes to TooFast state, as it exceeds the maximum allowed port speed (12880 KHz), calculated as (port speed \*

(number of configured source and destination tails + 1)). With 25 tails configured for each type of port mirroring, the bundle is in Running state only when the port speed is set to 256 KHz or less. As port speed is set to a constant value for T1/E1 ports, you cannot configure more than 7 tails for T1 ports or more than 5 tails for E1 ports. If you try to do so, the bundle goes to TooFast state.

You can configure source and destination port mirroring for a CTP device from CTPView.

To configure source and destination port mirroring for CTP bundles from the CTP Menu:

1. From the Main Menu, select **1) Bundle Operations > 1) CTP**.
2. Select a bundle from the list.
3. Select **2) Config> 11) Advanced Options> 10) Unidirectional circuit** and configure the parameters as described in [Table 33 on page 123](#).

**Table 33: Unidirectional and Bidirectional Circuit Options**

Field	Description
Unidirectional Circuit	<p>Select one:</p> <ul style="list-style-type: none"> <li>• Bidirectional circuit—Select to configure both source ad destination port mirroring.</li> <li>• Unidirectional circuit source—Select to configure only source port mirroring that enables mirroring network bound data.</li> </ul> <p><b>NOTE:</b> Source port mirroring is not supported for hairpin bundles (when source and remote destinations are on the same node) with IPv6 addressing.</p> <ul style="list-style-type: none"> <li>• Unidirectional circuit destination—Select to configure only destination port mirroring that enables mirroring interface bound data.</li> </ul> <p><b>NOTE:</b> Destination port mirroring is not supported for hairpin bundles with IPv4 or IPv6 addressing.</p>

4. Select **12) Port mirror Config**.

```
Current port mirror configuration: None
Options(0-quit, 1-add, 2-delete, 3-show): (0-3)[3]: 1
```

5. Enter **1** to configure port mirroring.
6. Follow the onscreen instructions and configure the parameters as described in [Table 34 on page 124](#).

Table 34: CTP Bundle Source Port Mirroring Settings in CTP Menu

Field	Your Action
Add Source mirroring	Select one: <ul style="list-style-type: none"> <li>• yes</li> <li>• no</li> </ul>
Enter remote ip address	Enter the remote IP address.
Enter remote cid	Enter the remote circuit ID in the range 0-249.
Add Destination mirroring	Select one: <ul style="list-style-type: none"> <li>• yes</li> <li>• no</li> </ul>
Enter remote ip address	Enter the remote IP address for the destination port.
Enter remote cid	Enter the remote circuit ID in the range 0-249.

7. From the Operations Menu, select **4) Activate** to activate the bundle.

## RELATED DOCUMENTATION

[Configuring Port Mirroring for CTP Bundles \(CTPView\) | 209](#)

## Configuring NetRef for Adaptive Bundle Operation

For NetRef adaptive bundle operation, the adaptive calculations are used to manage the node clock instead of the port clock as is done for a standard adaptive bundle. When the port is activated, the CTP device verifies whether:

- The port configured for adaptive clocking.
- NetRef is configured for adaptive port operation.

- The bundle number matches the bundle number that is configured in NetRef.

If the above requirements are met, a flag is set to indicate that the adaptive calculation for the port should manage the node clock instead of the port clock. The adjustment range in the adaptive calculation is limited to 0–4095 and is not set by the adaptive parameter **max ppb offset**. The port adaptive calculation continues to manage the node clock until the bundle is disabled.

To configure network node reference for adaptive bundle operation:

1. From the **Main Menu**, select **2) Node Synchronization**
2. Select **6) NetRef**.
3. From the NetRef Menu, select **1) NetRef**.

```
Enable NetRef (0=Off, 1=Master, 2=Slave, 3=Adaptive Bundle)? (0-3)[2]:
```

4. Enter **3** to select Adaptive Bundle.
5. Select **2) Adaptive Bundle** and specify the bundle number.

When you configure a node for NetRef adaptive bundle operation, you must specify the bundle number in the NetRef menu.

For adaptive bundle operation, the bundle must be configured for adaptive clocking and must be activated after you configure NetRef. NetRef adaptive bundle operation starts only after the bundle that is configured is activated. NetRef is disabled when you disable the bundle. To use the bundle without the NetRef feature, you must first disable the bundle, turn off NetRef adaptive bundle operation, and then re-enable the bundle.

**NOTE:** While configuring the network node reference for adaptive bundle operation, you only need to configure it on the adaptive end.

## RELATED DOCUMENTATION

[Network Node Reference Overview | 14](#)

[Configuring NetRef for Primary or Backup Operation | 125](#)

## Configuring NetRef for Primary or Backup Operation

NetRef primary backup operation involves a new packet flow from the primary node to all the backup nodes. These timing packets are sent at a rate of approximately 4.5 packets per second.

**NOTE:** In this topic, the terms *Primary* and *Backup* refer to primary and client operations or nodes, respectively.

To configure network node reference for primary or backup operation:

1. From the Main Menu, select **2) Node Synchronization**
2. Select **6) NetRef**
3. From the NetRef Menu, **1) NetRef**.

```
Enable NetRef (0=Off, 1=Master, 2=Slave, 3=Adaptive Bundle)? (0-3)[2]:
```

4. Enter **1** to select Primary mode or **2** to select Member mode.
5. Select **2) Remote Address** and specify the IP address of the NetRef client.

**NOTE:** When a node is configured for NetRef backup operation, the remote address must be configured to that of the primary node. Likewise, the NetRef primary node must be configured with the IP address of the NetRef backup node. A NetRef primary node can be configured to send data packets to up to 10 NetRef backup nodes.

## RELATED DOCUMENTATION

[Configuring NetRef for Adaptive Bundle Operation | 124](#)

[Network Node Reference Overview | 14](#)

## Configuring NetRef Multiple Primary Nodes (CTP Menu)

NetRef primary backup operation involves a new packet flow from the primary node to all the backup nodes. These timing packets are sent at a rate of approximately 4.5 packets per second.

**NOTE:** In this topic, the terms *Primary* and *Backup* refer to primary and client operations or nodes, respectively.

To configure network node reference with multiple primary nodes:

1. From the Main Menu, select **2) Node Synchronization**
2. Select **6) NetRef** to configure NetRef configuration parameters.

**NOTE:** You can select **1) 1st Priority, Reference 0**, **2) 2nd Priority, Reference 1**, **3) 3rd Priority, Reference 2**, **4) 4th Priority, Reference 3**, and **5) 5th Priority, Reference** to specify the prioritized node clock references. An external reference input and any of the serial interfaces may be used for the node reference clock. Reference frequencies must be 32 KHz, n x 64 KHz, or 1,544 KHz up to a maximum of 4096 KHz (2048 KHz maximum on the CTP1002).

3. From the NetRef Menu, **1) NetRef** to enable NetRef on the CTP device..

```
Enable NetRef (0=Off, 1=Master, 2=Slave, 3=Adaptive Bundle)? (0-3)[2]:
```

4. Enter **2** to select Member mode.
5. From the NetRef Menu, select **2) NetRef Master IP (Priority 1)**. and specify the IP address of the NetRef primary node, which is assigned a priority of 1.
6. From the NetRef Menu, select **3) NetRef Master IP (Priority 1)**. and specify the IP address of the NetRef primary node, which is assigned a priority of 2.
7. From the NetRef Menu, select **4) NetRef Master IP (Priority 1)**. and specify the IP address of the NetRef primary node, which is assigned a priority of 3.
8. From the NetRef Menu, select **5) NetRef Master IP (Priority 1)**. and specify the IP address of the NetRef primary node, which is assigned a priority of 4.

```
Please select a number from the following list:
```

```
-----
0) Exit to Shell
1) Bundle Operations
2) Node Synchronization
3) Node Summary
4) Node Diagnostics
5) Node Operations
6) Save Running Database to Flash
----- Your choice [3]: 2
```

```
=====
= (ctp_74 06/24/15 19:25:18 UTC) | Node Synchronization Menu
=====
```

```
Please select a number from the following list:
```

```
-----
```

```

0) Back to Previous Menu
1) 1st Priority, Reference 0: Disabled
2) 2nd Priority, Reference 1: Disabled
3) 3rd Priority, Reference 2: Disabled
4) 4th Priority, Reference 3: Disabled
5) 5th Priority, Reference 4: Disabled
6) NetRef:                Disabled
7) 32 kHz Ref Output:     NO
8) Query Node Sync Status
9) Measure Ref Inputs
10) Calibrate Node to Current Reference
----- Your choice [6]: 6

```

```

=====
= (ctp_74 06/24/15 19:25:38 UTC) | NetRef Menu
=====

```

Please select a number from the following list:

```

-----
0) Back to Previous Menu
1) NetRef:                Disabled
----- Your choice [1]: 1
Enable NetRef (0=Off, 1=Master, 2=Slave, 3=Adaptive Bundle)? (0-3)[0]: 2

```

```

=====
= (ctp_74 06/24/15 19:25:42 UTC) | NetRef Menu
=====

```

Please select a number from the following list:

```

-----
0) Back to Previous Menu
1) NetRef:                Slave
2) NetRef Master IP (Priority 1): 127.0.0.1
3) NetRef Master IP (Priority 2): 127.0.0.1
4) NetRef Master IP (Priority 3): 127.0.0.1
5) NetRef Master IP (Priority 4): 127.0.0.1
----- Your choice [2]: 2

```

Configure a NetRef Master? n[y]: y

Enter remote node IP address for NetRef:(rtn for 127.0.0.1)? 10.216.118.73



```
=====
= (ctp_74 10/30/15 12:22:08 UTC) | NetRef Menu
=====
```

Please select a number from the following list:

- ```
-----
0) Back to Previous Menu
1) NetRef:          Slave
2) NetRef Master IP (Priority 1): 10.216.118.73
3) NetRef Master IP (Priority 2): 127.0.0.1
4) NetRef Master IP (Priority 3): 127.0.0.1
5) NetRef Master IP (Priority 4): 127.0.0.1
----- Your choice [2]: 3
```

Configure a NetRef Master? n[y]: y

Enter remote node IP address for NetRef:(rtn for 127.0.0.1)? 10.216.118.86

```
=====
= (ctp_74 10/30/15 12:48:56 UTC) | NetRef Menu
=====
```

Please select a number from the following list:

- ```
-----
0) Back to Previous Menu
1) NetRef:          Slave
2) NetRef Master IP (Priority 1): 10.216.118.73
3) NetRef Master IP (Priority 2): 10.216.118.86
4) NetRef Master IP (Priority 3): 127.0.0.1
5) NetRef Master IP (Priority 4): 127.0.0.1
----- Your choice [3]: 4
```

Configure a NetRef Master? n[y]: y

Enter remote node IP address for NetRef:(rtn for 127.0.0.1)? 10.216.118.90

```
=====
= (ctp_74 10/30/15 12:49:04 UTC) | NetRef Menu
=====
```

Please select a number from the following list:

```

-----
0) Back to Previous Menu
1) NetRef:           Slave
2) NetRef Master IP (Priority 1): 10.216.118.73
3) NetRef Master IP (Priority 2): 10.216.118.86
4) NetRef Master IP (Priority 3): 10.216.118.90
5) NetRef Master IP (Priority 4): 127.0.0.1
----- Your choice [4]: 5

```

Configure a NetRef Master? n[y]: y

Enter remote node IP address for NetRef:(rtn for 127.0.0.1)? 10.216.118.88

```

=====
= (ctp_74 10/30/15 12:49:12 UTC) | NetRef Menu
=====

```

Please select a number from the following list:

```

-----
0) Back to Previous Menu
1) NetRef:           Slave
2) NetRef Master IP (Priority 1): 10.216.118.73
3) NetRef Master IP (Priority 2): 10.216.118.86
4) NetRef Master IP (Priority 3): 10.216.118.90
5) NetRef Master IP (Priority 4): 10.216.118.88
----- Your choice [5]:

```

**NOTE:** When a node is configured for NetRef backup operation, the remote address must be configured to that of the primary node. Likewise, the NetRef primary node must be configured with the IP address of the NetRef backup node. A NetRef primary node can be configured to send data packets to up to 10 NetRef backup nodes.

Rate selection and clock configuration allow the serial interface rate to be configured through the software. Rates supported range from less than 300 bps to 12.288 Mbps (in subhertz increments). You can configure the CTP systems by using the menu interface to provide multiple prioritized node clock references. An external reference input and any of the serial interfaces

may be used for the node reference clock. Reference frequencies must be 32 KHz, n x 64 KHz, or 1,544 KHz up to a maximum of 4096 KHz (2048 KHz maximum on the CTP1002).

Follow the onscreen instructions and configure the options as described in [Table 35 on page 131](#).

**Table 35: Configuring Multiple NetRef Primary Node IP Addresses**

Field	Function	Your Action
NetRef Master IP (Priority)	Specifies whether you want to configure multiple primary nodes with priorities, which can be used to transmit clocking information to the backup nodes in NetRef.	Enter 2, 3, 4, and 5 to configure NetRef primary nodes with priorities 1, 2, 3, and 4, respectively.
Configure a NetRef Master? n[y]	Specifies whether you want to configure a NetRef primary node.	Specify y or n.
Enter remote node IP address for NetRef	Specifies the IP address of the NetRef primary node.	Specify IP address of the NetRef primary node assigned with different priorities.  Specify rtn to set the IP address of 127.0.0.1 interface that is prompted by the system to be specified as the default IPv4 address of the primary node. For example, if the prompt displays (rtn for 127.0.0.1), and if you specify rtn, 127.0.0.1 is set as the default IP address.

## RELATED DOCUMENTATION

[Configuring NetRef for Adaptive Bundle Operation | 124](#)

[Network Node Reference Overview | 14](#)

## Configuring NetRef Settings (CTPView)

NetRef primary backup operation involves a new packet flow from the primary node to all the backup nodes. These timing packets are sent at a rate of approximately 4.5 packets per second.

**NOTE:** In this topic, the terms *Primary* and *Backup* refer to primary and client operations or nodes, respectively.

To configure network node reference with primary and backup operation using the Node Configuration page of CTPView:

1. In the side pane, select **Node > Node Config**.
2. Configure the parameters described in [Table 36 on page 132](#) and click **Submit Configuration**.
3. (Optional) Click **Node > Node Query** to verify the NetRef primary and backup node configuration details.

**Table 36: Node Configuration Settings Page in CTPView**

Field	Function	Your Action
Port Providing Reference	<p>Specifies whether you want to enable or disable the NetRef primary node to function as the reference port providing frequency for clock synchronization.</p> <p>You need to specify this value for the <b>1st Priority Reference 0, 2nd Priority Reference 1, 3rd Priority Reference 2, 4th Priority Reference 3, and 5th Priority Reference 4</b> fields to specify the reference clocks for the primary nodes with corresponding priorities.</p>	Select <b>Yes</b> or <b>No</b> to enable or disable the primary node to function as the reference clock.

Table 36: Node Configuration Settings Page in CTPView (Continued)

Field	Function	Your Action
Reference Frequency	<p>Specifies the frequency to be used for the reference clock or the primary node.</p> <p>You need to specify this value for the <b>1st Priority Reference 0, 2nd Priority Reference 1, 3rd Priority Reference 2, 4th Priority Reference 3, and 5th Priority Reference 4</b> fields to specify the reference clocks for the primary nodes with corresponding priorities.</p>	<p>Select a reference frequency in the range from 32 KHz through 4096 KHz.</p> <p>You can configure the CTP systems by using the menu interface to provide multiple prioritized node clock references. An external reference input and any of the serial interfaces may be used for the node reference clock. Reference frequencies must be 32 KHz, n x 64 KHz, or 1,544 KHz up to a maximum of 4096 KHz (2048 KHz maximum on the CTP1002).</p>
NetRef: Slave	Specifies the client node for which multiple primary nodes are associated for receiving clock synchronization information.	Select the client node to be locked to the different primary nodes.
Master IP (Priority # 1)	Specifies the IP address of the primary node with priority 1.	Enter the IP address of the primary node with priority 1.
Master IP (Priority # 2)	Specifies the IP address of the primary node with priority 2.	Enter the IP address of the primary node with priority 2.
Master IP (Priority # 3)	Specifies the IP address of the primary node with priority 3.	Enter the IP address of the primary node with priority 3.
Master IP (Priority # 4)	Specifies the IP address of the primary node with priority 4.	Enter the IP address of the primary node with priority 4.
32 kHz Reference Output	Specifies whether you want to enable the reference output signal.	Select the <b>Enable</b> check box if it is already disabled.
Clock Main RTM	Specifies the clock rear transition module (RTM) used to input a reference clock into the CTP2000 platform.	Select a value from the Port DB25 drop-down list to use clock module RTM.

## Configuring LOS Detection on CTP and SAToP Bundles (CTP Menu)

Starting with CTPOS Release 7.2R1, CTP devices support the detection of a loss of signal, which denotes a physical link problem. The following conditions are supported:

- In a serial both-ended Y-cable redundancy configuration (hardware-based redundancy or software-based Y cable link protocol), removal of Y cable leg from the CTP port of the online bundle must be able to force a switch to the standby bundle.
- In a T1/E1 both-ended Y cable configuration (hardware-based redundancy or software-based Y cable link protocol), removal of Y cable leg from the CTP port of the online bundle must be able to force a switch to the standby bundle.

A CTP series device provides two types of Y-cable redundancy.

- Redundancy by using a hardware link that uses a special Y cable
- Redundancy by using a software link that does not depend on a signaling hardware like the Y cable

Before you begin:

- Disable the bundle before you modify the bundle options.

The CTP devices support a both-ended redundancy mechanism, in which two identical CTP circuit bundles are combined using Y cables at each end, enabling one bundle to act as a backup for the other. One of the bundles is in use (online), while the other is in the standby state (offline). Only the online bundle is allowed to drive the Y cable towards the user equipment, while the offline bundle is tristate. A communications channel (such as redundancy by using a hardware link that uses a special Y cable or redundancy based on a software link that does not depend on a signaling hardware like the Y cable) between ports at each end determines which of the two ports on the Y cable is currently online. When one bundle fails, the failed bundle transitions to the offline and places the other bundle in the online state.

To configure the capability to detect LOS alarms in a Y-cable redundancy configuration for CTP and SAToP bundles by using the CTP Menu:

1. From the Main Menu, select **1) Bundle Operations**.
2. Select **1) CTP**.
3. Select a bundle from the list.
  - If you select an active bundle, you are prompted to disable the bundle before configuring it.
4. Select **3) Port Config**.
5. Select **4) Advanced Options** to configure advanced attributed for the CTP bundle.
6. Select **20) LOS checking (T1E1 only)** to configure the functionality to detect LOS for the T1E1 interfaces in a CTP bundle or SAToP bundle.

7. Follow the onscreen instructions and configure the options as described [Table 37 on page 135](#).

**Table 37: LOS Settings in the CTP Menu**

Field	Function	Your Action
Check LOS on T1/E1 ports for CTP/SAToP bundles? y[n]	<p>Specifies that the capability to identify LOS alarms on T1E1 interfaces in SAToP or CTP bundles needs to be enabled.</p> <p>A loss of signal (LOS) alarm indicates that there is a physical link problem with the connection to the router receive port from the neighboring SONET equipment transmit port. An LOS alarm occurs when the port on the card is in service but no signal is being received. The cabling is not correctly connected to the ports, or no signal exists on the line. Possible causes for a loss of signal include upstream equipment failure or a fiber cut.</p>	<p>Enter y or n to enable or disable the LOS detection capability.</p> <p><b>NOTE:</b> Although this menu option to enable or disable the LOS detection functionality is shown regardless of the port type, such as serial interfaces or T1E1 interfaces, this setting becomes effective on a T1/E1 port only when it is connected to a CTP or SAToP bundle. If the LOS detection functionality is enabled on a serial port or other bundle types, the setting is not processed.</p>

## Configuring Cryptographic Resynchronization (Crypto Resync)

You can use the CTP chassis with cryptographic devices. You can configure synchronized (in-sync) and pulse cryptographic resynchronized (resync) options for use with these devices.

If an error occurs on a secure link, the cryptographic devices can get out of sync. When the CTP software detects that a cryptographic device is out of sync or that keepalives or LMI has been lost, it signals to the cryptographic device to resync by pulsing DSR and/or CTS.

The NRZ port has a configuration parameter for cryptographic resynchronization where you need to specify a port that is on the same node and is monitored. The port has to be a Fractional T1/E1 port that has Frame transport Enabled. When the bundle that includes these ports is up and running, the cryptographic resynchronization function monitors the frame synchronization bit of the framer in the east bound direction, and if the framer indicates loss of frame, then the cryptographic function is activated.

You can configure how long the CTP software waits before requesting a resynchronization, set the pulse width, and set the pulse period of the resynchronization request. You can also configure the direction of the pulse (0 to 1 or 1 to 0). To disable the pulse, set the in-sync and pulse value to the same value.

To configure cryptographic resynchronization:

1. From the CTP Main Menu, select **1) Bundle Operations >**
2. Select **1) CTP.**
3. Select a bundle from the list.
4. Select **3) Port Config > 4) Advanced Options > 11) Remote Port T1E1 crypto**

```
This option allows this port to output a crypto resync
pulse based on the T1/E1 frame status (i/f bound) of another port.
The port must be a T1/E1 port or Serial port with T1E1 DCARD.
The port must be configured for fractional T1/E1 w/ frame transport
The port must be on this node.
```

```
Would you like to enable this feature? y[n]:
Enter T1/E1 Port [se-0/0]:
```

5. Enter **y** and select a T1E1 port when prompted..
6. **12) Crypto Options**

```
0) Back to Previous Menu
1) Crypto resync wait time:      4 sec
2) Crypto resync pulse width:   1 sec
3) Crypto resync pulse period:  8 sec
4) Crypto resync DSR in-sync value: 1 (mark/high/off)
5) Crypto resync DSR pulse value: 0 (space/low/on)
6) Crypto resync CTS in-sync value: 1 (mark/high/off)
7) Crypto resync CTS pulse value: 0 (space/low/on)
```

7. Configure the cryptographic resynchronization options as described in [Table 38 on page 137](#)



**Table 38: Cryptographic Resynchronization Options**

Field Name	Field Description
Crypto resync wait time	<p>Number of seconds to wait between loss of sync on the port and the first resynchronization pulse.</p> <p>Enter a value in the range 1 – 60. The default value is 4 seconds</p>
Crypto resync pulse width	<p>Pulse width in seconds. This is the number of seconds the resynchronization pulse will be asserted.</p> <p>Enter a value in the range 1 -15. the default value is 1 second</p>
Crypto resync pulse period	<p>Number of seconds between the beginning of each pulse. This value minus the pulse width equals the time between the end of one pulse and the beginning of the next pulse.</p> <p>Enter a value in the range 1-1000. The default value is 8 seconds.</p>
Crypto resync DSR in-sync value	<p>State of DSR or DTR when the port is in sync.</p> <p>Enter a value in the range 0-1. The default value is 1.</p>
Crypto resync DSR pulse value	<p>State of DSR or DTR to be sent between the resynchronization pulses when the port is out of sync.</p> <p>Enter a value in the range 0-1. The default value is 0.</p>
Crypto resync CTS in-sync value	<p>State of CTS or RTS when the port is in sync.</p> <p>Enter a value in the range 0-1. The default value is 1.</p>
Crypto resync CTS pulse value	<p>State for CTS or RTS to be sent between the resynchronization pulses when the port is out of sync.</p> <p>Enter a value in the range 0-1. The default value is 0.</p>

## Gathering Node Debugging Information (CTP Menu)

This topic describes how to enable gathering node debugging information on CTP devices.

To enable gathering node debugging information using the CTP Menu:

1. From the Main Menu, select **4) Node Diagnostics**.
2. Select **10) Node debug data gathering**.
3. Select **1) Enable** to enable gathering node debugging information.

The functionality of gathering node debugging information is disabled by default.

# Configuring CTP Bundles (CTPView)

## IN THIS CHAPTER

- Adding a Bundle (CTPView) | 140
- Configuring IP Parameters for CTP Bundles (CTPView) | 140
- Configuring Circuit Startup Parameters for CTP Bundles (CTPView) | 143
- Configuring the Direction of the Circuit (CTPView) | 145
- Configuring Virtual IP Parameters for CTP Bundles (CTPView) | 146
- Configuring the Missing Packet Fill Pattern for CTP Bundles (CTPView) | 147
- Configuring Signaling for CTP Bundles (CTPView) | 148
- Configuring Multiservice Port Parameters for CTP Bundles (CTP Menu) | 154
- Configuring Serial Port Parameters for CTP Bundles (CTPView) | 163
- Configuring Transparent Encoding for CTP Bundles (CTPView) | 167
- Configuring Bundle Pairs for TDM/TDC Operation (CTPView) | 171
- Configuring T1 and E1 Port Parameters for CTP Bundles (CTPView) | 173
- Configuring Multiservice Port Parameters for CTP Bundles (CTPView) | 177
- Configuring 4WTO Port Parameters for CTP Bundles (CTPView) | 186
- Configuring IRIG-B Port Parameters for CTP Bundles (CTPView) | 191
- Configuring Advanced Port Options for CTP Bundles (CTPView) | 194
- Selecting the Type of Clocking on Serial Ports for CTP Bundles (CTPView) | 196
- Configuring Custom Clocking for CTP Bundles (CTPView) | 199
- Configuring Adaptive Clocking for CTP Bundles (CTPView) | 203
- Configuring PBS and Bridge Ports (CTPView) | 206
- Configuring Port Mirroring for CTP Bundles (CTPView) | 209
- Configuring NetRef Settings (CTPView) | 214

## Adding a Bundle (CTPView)

Before you begin:

- Log in to the CTPView software at least at the Net\_Admin level.
- Connect the CTPView server to the CTP device for which you want to configure bundles.

To add a bundle using CTPView:

1. In the side pane, select **Bundle > Configuration**.
2. Run your mouse over the **Open Add Bundles Display** bar.
3. Under **New Bndl Number**, select a bundle number.
4. Under the type of bundle you want to add, select a source port and click the button for the type of bundle.

Before you create a VComp bundle, you must ensure that the CTP system has a VComp card installed. The CTP system displays a warning message if no VComp card is installed. If you create a VComp bundle on a CTP system that does not have a VComp card installed and try to activate it, the CTP system displays the following warning message:

There is not enough system DSP resource for the bundle.

The bundle remains disabled until you install a VComp card and activate the bundle again. If you remove the VComp card from a CTP system that has an active VComp bundle, the Run state of the VComp bundle changes to MisCfg.

5. Enter the parameters and click **Click to Submit Bundle AND Port Changes**.

## Configuring IP Parameters for CTP Bundles (CTPView)

The CTP software uses the IP parameters to create IP packets.

Before you begin:

- Log in to the CTPView software at least at the Net\_Admin level.
- Connect the CTPView server to the CTP device for which you want to configure bundles.

To configure IP parameters for CTP bundles using CTPView:

1. In the side pane, select **Bundle > Configuration**.
2. Run your mouse over the **Display and Select an Existing Bundle** bar.

3. In the table of bundles, select the bundle that you want to modify.
4. Under **Bundle Options**, configure the parameters as described in [Table 39 on page 141](#) and click **Click to Submit Bundle AND Port Changes**.

**Table 39: CTP Bundle IP Parameter Settings in CTPView**

Field	Function	Your Action
Bundle Description	Specifies identifying information about the bundle.  You can use the bundle description as the search criteria when you search for bundles from the network monitoring page.	Type a description for the bundle.
State	Specifies whether the bundle is active or disabled.	Select <b>DISABLED</b> or <b>ACTIVE</b> .
Remote Address	Specifies the name and IP address of the remote CTP device.	In the first field, select the CTP device.  In the second field, select an interface on the CTP device.
Remote Circuit ID	Specifies the bundle to connect to on the remote CTP device.	Enter a number from 0 through 249.
Local Circuit ID	Specifies the bundle on the local CTP device.	Enter a number from 0 through 249.
Packet Size	Specifies the size of IP packets that are created from data received at the serial port.  The CTP device makes sure that the combination of packet size and data rate does not result in a packet rate that exceeds 1200 packets per second.	Select a packet size.  For CTP150 devices, the available packet size is 8 through 1456.  For CTP2000 devices, the available packet size is 4 through 1456.

Table 39: CTP Bundle IP Parameter Settings in CTPView (Continued)

Field	Function	Your Action
Min Buffer	<p>Specifies the minimum average buffer size. Use a value that is greater than the expected jitter and less than the Buffer Set parameter.</p> <p>The minimum buffer ensures that the buffer does not become too small because of timing variances between the local and remote serial interfaces.</p> <p>The entire buffer is available for accommodating and smoothing packet delay jitter, regardless of the minimum buffer setting.</p>	Enter a number from 0.001 through 9999.000 milliseconds.
Buffer Set	Specifies the buffer size when the circuit enters a running state. This value must be large enough to accommodate the anticipated packet delay, and it must be set to a value greater than the minimum buffer size and lower than the maximum buffer size.	Enter a number from 0.001 through 9999.000 milliseconds.
Max Buffer	<p>Specifies the maximum buffer size. The maximum buffer ensures that the buffer does not become too large due to timing variances between the local and remote serial interfaces. If the buffer size exceeds the maximum buffer size, the buffer is recentered to the Buffer Set value.</p> <p>Periodic buffer recenters are not expected. If you notice recenters, we recommend that you verify the reference to the CTP (if used) or that you configure one port with adaptive clocking.</p>	Enter a number from 0.001 through 9999.000 milliseconds.
Service Type	<p>Specifies the ToS byte to be used in the IP headers of packets sent from the CTP device to the IP network.</p> <p>For a mapping of ToS byte values to DSCP classes and settings, see <a href="#">Providing QoS for CTP Bundles by Using Service Type Overview</a>.</p> <p>You do not need to set the ToS value to the same value on local and remote bundles.</p>	Enter a number from 0 through 255.

Table 39: CTP Bundle IP Parameter Settings in CTPView (Continued)

Field	Function	Your Action
Time to Live	Specifies the maximum number of router hops that a packet can traverse. The CTP device sets the TTL value in IP packets that it sends to the IP network. The IP network does not alter or optimize the packet routing based on the TTL setting. You do not need to set the same TTL value on local and remote ports.	Enter a number from 0 through 255.

## RELATED DOCUMENTATION

[Determining Optimal Packet Size for CTP Bundles Overview | 8](#)

[Providing QoS for CTP Bundles by Using Service Type Overview](#)

## Configuring Circuit Startup Parameters for CTP Bundles (CTPView)

This topic describes how to configure advanced options that are related to circuit startup. Set these parameters to the same values on the local and remote CTP devices.

Before you begin:

- Log in to the CTPView software at least at the Net\_Admin level.
- Connect the CTPView server to the CTP device for which you want to configure bundles.

To configure circuit startup parameters for CTP bundles using CTPView:

1. In the side pane, select **Bundle > Configuration**.
2. Run your mouse over the **Display and Select an Existing Bundle** bar.
3. In the table of bundles, select the bundle that you want to modify.
4. Under **Bundle Options**, select **Advanced Options Show** to display advanced parameters and configure the parameters as described in [Table 40 on page 144](#).
5. Click **Click to Submit Bundle AND Port Changes**.

Table 40: CTP Bundle Advanced Options Parameter Settings for Circuit Startup in CTPView

Field	Function	Your Action
OAM Packet Spacing	Specifies the number of OAM packets per second that the circuit sends to the remote CTP device.	Enter a number from 1 through 255.
OAM Packets for Sync	Specifies the number of OAM packets that the circuit must receive before the state moves from no synchronization to in synchronization.	Enter a number from 1 through 255.
OAM Packets for Sync Loss	Specifies the number of received OAM packets that the CTP device misses before the state of the circuit moves from in synchronization to no synchronization.	Enter a number from 1 through 255.
Consecutive Pkt Loss To Starvation	<p>Specifies how many consecutive circuit packets the IP network must drop before the CTP device restarts the circuit.</p> <p>We recommend that you set the parameter to a larger value when the IP network uses packet-encrypting devices. These devices cause momentary interruption in packet flows when encryption keys are updated.</p>	Enter a number from 1 through 64.
InSync Pkts After Starvation	Specifies the number of in-sequence packets the CTP device must receive after a starvation before the circuit transitions from in-sync to running.	Enter a number from 1 through 64.



**Table 40: CTP Bundle Advanced Options Parameter Settings for Circuit Startup in CTPView**  
(Continued)

Field	Function	Your Action
OAM-free CTP bundle	Specifies whether to use the full duplex OAM communication to bring CTP bundle to the running state.	<p>Select one:</p> <ul style="list-style-type: none"> <li>No—CTP bundle uses the full duplex OAM communication to bring CTP bundle to the running state. When a bundle is activated, the CTP device sends OAM packets to the remote circuit until the required number of packets is received. The circuit then changes its state to 'running' and begins sending data packets.</li> <li>Yes—CTP bundle does not use the full duplex OAM communication to bring CTP bundle to the running state. When a bundle is activated, the circuit directly changes its state to 'running' and begins sending data packets. When set to 'Yes', other bundle OAM parameter values are ignored.</li> </ul>

## RELATED DOCUMENTATION

[Circuit Startup Process Overview](#) | 13

## Configuring the Direction of the Circuit (CTPView)

This topic describes how to configure the direction of the circuit.

Before you begin:

- Log in to the CTPView software at least at the Net\_Admin level.
- Connect the CTPView server to the CTP device for which you want to configure bundles.

To configure the direction of circuits created with the CTP bundle using CTPView:

1. In the side pane, select **Bundle > Configuration**.
2. Run your mouse over the **Display and Select an Existing Bundle** bar.
3. In the table of bundles, select the bundle that you want to modify.
4. Under **Bundle Options**, configure the parameters as described in [Table 41 on page 146](#) and click **Click to Submit Bundle AND Port Changes**.

**Table 41: CTP Bundle Circuit Direction Setting in CTPView**

Field	Function	Your Action
Unidirectional Circuit	Specifies whether the circuit is unidirectional or bidirectional. If unidirectional, specify the direction of the circuit—source or destination.	Select one: <ul style="list-style-type: none"> <li>• BI-DIRECTIONAL—Circuit is bidirectional.</li> <li>• SOURCE—Circuit is unidirectional, and this end of the circuit is the source.</li> <li>• DESTINATION—Circuit is unidirectional, and this end of the circuit is the destination.</li> </ul>

## Configuring Virtual IP Parameters for CTP Bundles (CTPView)

The virtual IP parameters allow you to use a separate IP address for each bundle and to use an address that is different from the IP address for the CTP device. If you configure the IP address on the:

- Same subnet as the CTP IP address, you do not need a static route on the router.
- Different subnet as the CTP IP address, you need a static route on the router.

Before you begin:

- Log in to the CTPView software at least at the Net\_Admin level.
- Create a list of the virtual IP addresses that will be associated with the CTP device. To do so, select **Node > Maintenance > Configure CTP Device Virtual IPs**, and follow the instructions on the pane. You can create up to 100 virtual IP addresses (IPv4 only).

When you submit your new configuration, the CTP device reboots.

- Connect the CTPView server to the CTP device for which you want to configure bundles.

To configure virtual IP parameters for CTP bundles using CTPView:

1. In the side pane, select **Bundle > Configuration**.
2. Run your mouse over the **Display and Select an Existing Bundle** bar.
3. In the table of bundles, select the bundle that you want to modify.
4. Under **Bundle Options**, select **Advanced Options Show** to display advanced parameters and configure the parameters as described in [Table 42 on page 147](#).
5. Click **Click to Submit Bundle AND Port Changes**.

**Table 42: CTP Bundle Virtual IP Parameter Settings in CTPView**

Field	Function	Your Action
Use Virtual IP	<p>Specifies whether or not the bundle uses an address that is different from the IP address of the CTP device.</p> <p>The virtual IP address is used in the IP packet's Origination Address field, and is used for the circuit's data and OAM flow.</p>	<p>Select one:</p> <ul style="list-style-type: none"> <li>• <b>DISABLED</b>—Circuits created by this bundle use the IP address of the CTP device.</li> <li>• <b>ENABLED</b>—Circuits created by this bundle use an address that is different from the CTP device.</li> </ul>
Virtual IP [ IPv4 only ]	<p>Specifies the virtual IP address for circuits created by this bundle.</p>	<p>Enter the virtual IP address.</p> <p>At the remote end of the bundle, specify this IP address as the Remote Address of the bundle.</p>

## Configuring the Missing Packet Fill Pattern for CTP Bundles (CTPView)

This topic describes how to specify the fill pattern that the CTP device inserts when IP packets are dropped.

Before you begin:

- Log in to the CTPView software at least at the Net\_Admin level.
- Connect the CTPView server to the CTP device for which you want to configure bundles.

To configure the missing packet fill pattern for CTP bundles using CTPView:

1. In the side pane, select **Bundle > Configuration**.
2. Run your mouse over the **Display and Select an Existing Bundle** bar.
3. In the table of bundles, select the bundle that you want to modify.

4. Under **Bundle Options**, select **Advanced Options Show** to display advanced parameters and configure the parameters as described in [Table 43 on page 148](#).
5. Click **Click to Submit Bundle AND Port Changes**.

**Table 43: CTP Bundle Missing Packet Fill Pattern Parameter Setting in CTPView**

Field	Function	Your Action
Missing Packet Fill Pattern	<p>Specifies the data that the CTP device inserts into the circuit bit stream when an IP packet is dropped. The number of bits inserted is equal to the number of bits in the missed packet.</p> <p>When the bundle is down, the port sends the value of the least significant bit (LSB) of the missing fill pattern.</p> <p>This data insertion method prevents a loss of bit count integrity to attached circuit devices and encryptors.</p>	Enter two hexadecimal digits. You must enter a value other than ff. This field does not require the 0x characters.

To resolve the issue of missing packet which may also be due to the packets arriving late, increase the bundle buffer until the late packets do not happen. Alternatively, you can use QoS feature to provide better network latency to packets used for CTP bundles.

See [Providing QoS for CTP Bundles by Using Service Type Overview](#)

## Configuring Signaling for CTP Bundles (CTPView)

You can set input and output signals for the CTP device. Your settings should be based on the settings of the user equipment.

- Output signals—You can set output signals to a fixed value, or you can set them to inband so that the output signal state is based on the state of the input signal at the user equipment. Output signals that you can set vary depending on whether the bundle is configured as the DTE or the DCE:
  - DTE output signals:
    - DTR (data set ready)
    - RTS (request to send)
    - LL (local loopback)
    - RL (remote loopback)
  - DCE output signals:

- DSR (data set ready)
  - CTS (clear to send)
  - DCD (data carrier detect)
  - TM (test mode)
- Input signals—You can set the input signals to either unused (ignored) or used to create a demand circuit. When configured for demand, packets created from the circuit are transferred across the IP network only when the signal lead is in the specified state for the circuit to be **Demand Call - Active**. When two or more leads are configured for demand, all configured leads must be in the **Demand Call - Active** state for the circuit to transfer packets across the IP network.

Input signals that you can set vary depending on whether the bundle is configured as the DTE or the DCE:

- DTE—Input signals are TM, CTS, DSR, DCD.
- DCE—Input signals are RL, RTS, DTR, LL.

The input state of each signal lead is encoded once in every transmitted IP packet. Thus the granularity of the transitions (frequency or changes) that can be transferred across the network is equal to the packet rate of the circuit.

Before you begin:

- Log in to the CTPView software at least at the Net\_Admin level.
- Connect the CTPView server to the CTP device for which you want to configure bundles.

To configure signaling for CTP bundles using CTPView:

1. In the side pane, select **Bundle > Configuration**.
2. Run your mouse over the **Display and Select an Existing Bundle** bar.
3. In the table of bundles, select the bundle that you want to modify.
4. Under **Bundle Options**, select **Advanced Options Show** to display advanced parameters and configure the parameters as described in [Table 44 on page 150](#).
5. Click **Click to Submit Bundle AND Port Changes**.

Table 44: CTP Bundle Signaling Settings in CTPView

Field	Function	Your Action
Signal Out - Output Delay	Specifies the output signaling delay in packets.	Select the number of packets: <ul style="list-style-type: none"> <li>• 0</li> <li>• 1</li> <li>• 2</li> <li>• 3</li> </ul>
Signal Out - DSR	Specifies the DSR output signal from the port interface (when configured as DCE).	Select one: <ul style="list-style-type: none"> <li>• Fixed - ON/0/Space/Low—Signal is turned on.</li> <li>• Fixed - OFF/1/Mark/High—Signal is turned off.</li> </ul>
Signal Out - DTR	Specifies the DTR output signal from the port interface (when configured as DTE).	<ul style="list-style-type: none"> <li>• InBand - From Remote RL—Output signal is based on the state of the RL input signal from the remote port interface (when configured as DCE), or the TM signal from the remote port interface (when configured as DTE).</li> <li>• InBand - From Remote RTS—Output signal is based on the state of the RTS input signal from the remote port interface (when configured as DCE), or the CTS signal from the remote port interface (when configured as DTE).</li> <li>• InBand - From Remote DTR—Output signal is based on the state of the DTR input signal from the remote port interface (when configured as DCE), or the DSR signal from the remote port interface (when configured as DTE).</li> <li>• InBand - From Remote LL—Output signal is based on the state of the LL input signal from the remote port interface (when configured as DCE), or the DCD signal from the remote port interface (when configured as DTE).</li> </ul>
Signal Out - CTS	Specifies the CTS output signal from the port interface (when configured as DCE).	Select one: <ul style="list-style-type: none"> <li>• Fixed - ON/0/Space/Low—Signal is turned on.</li> <li>• Fixed - OFF/1/Mark/High—Signal is turned off.</li> </ul>

Table 44: CTP Bundle Signaling Settings in CTPView (Continued)

Field	Function	Your Action
Signal Out - RTS	Specifies the RTS output signal from the port interface (when configured as DTE).	<ul style="list-style-type: none"> <li>• InBand - From Remote RL—Output signal is based on the state of the RL input signal from the remote port interface (when configured as DCE), or the TM signal from the remote port interface (when configured as DTE).</li> <li>• InBand - From Remote RTS—Output signal is based on the state of the RTS input signal from the remote port interface (when configured as DCE), or the CTS signal from the remote port interface (when configured as DTE).</li> <li>• InBand - From Remote DTR—Output signal is based on the state of the DTR input signal from the remote port interface (when configured as DCE), or the DSR signal from the remote port interface (when configured as DTE).</li> <li>• InBand - From Remote LL—Output signal is based on the state of the LL input signal from the remote port interface (when configured as DCE), or the DCD signal from the remote port interface (when configured as DTE).</li> </ul>
Signal Out - DCD	Specifies the DCD output signal from the port interface (when configured as DCE).	<p>Select one:</p> <ul style="list-style-type: none"> <li>• Fixed - ON/0/Space/Low—Signal is turned on.</li> <li>• Fixed - OFF/1/Mark/High—Signal is turned off.</li> <li>• InBand - From Remote RL—Output signal is based on the state of the RL input signal from the remote port interface (when configured as DCE), or the TM signal from the remote port interface (when configured as DTE).</li> <li>• InBand - From Remote RTS—Output signal is based on the state of the RTS input signal from the remote port interface (when configured as DCE), or the CTS signal from the remote port interface (when configured as DTE).</li> <li>• InBand - From Remote DTR—Output signal is based on the state of the DTR input signal from the remote port interface (when configured as DCE), or the DSR signal from the remote port interface (when configured as DTE).</li> </ul>

Table 44: CTP Bundle Signaling Settings in CTPView (Continued)

Field	Function	Your Action
Signal Out - LL	Specifies the LL output signal from the port interface (when configured as DTE).	<ul style="list-style-type: none"> <li>InBand - From Remote LL—Output signal is based on the state of the LL input signal from the remote port interface (when configured as DCE), or the DCD signal from the remote port interface (when configured as DTE).</li> </ul>
Signal Out - TM	Specifies the TM output signal from the port interface (when configured as DCE).	<p>Select one:</p> <ul style="list-style-type: none"> <li>Fixed - ON/0/Space/Low—Signal is turned on.</li> <li>Fixed - OFF/1/Mark/High—Signal is turned off.</li> </ul>
Signal Out - RL	Specifies the RL output signal from the port interface (when configured as DTE).	<ul style="list-style-type: none"> <li>InBand - From Remote RL—Output signal is based on the state of the RL input signal from the remote port interface (when configured as DCE), or the TM signal from the remote port interface (when configured as DTE).</li> <li>InBand - From Remote RTS—Output signal is based on the state of the RTS input signal from the remote port interface (when configured as DCE), or the CTS signal from the remote port interface (when configured as DTE).</li> <li>InBand - From Remote DTR—Output signal is based on the state of the DTR input signal from the remote port interface (when configured as DCE), or the DSR signal from the remote port interface (when configured as DTE).</li> <li>InBand - From Remote LL—Output signal is based on the state of the LL input signal from the remote port interface (when configured as DCE), or the DCD signal from the remote port interface (when configured as DTE).</li> </ul>
Signal In - RL	Specifies the RL input signal from the port interface (when configured as DCE).	<p>Select one:</p> <ul style="list-style-type: none"> <li>Unused—Input signals are ignored.</li> <li>Demand Call - Active High—Signal is turned off.</li> </ul>
Signal In - TM	Specifies the TM input signal from the port interface (when configured as DTE).	<ul style="list-style-type: none"> <li>Demand Call - Active Low—Signal is turned on.</li> </ul>



Table 44: CTP Bundle Signaling Settings in CTPView (Continued)

Field	Function	Your Action
Signal In - RTS	Specifies the RTS input signal from the port interface (when configured as DCE).	Select one: <ul style="list-style-type: none"> <li>Unused—Input signals are ignored.</li> <li>Demand Call - Active High—Signal is turned off.</li> </ul>
Signal In - CTS	Specifies the CTS input signal from the port interface (when configured as DTE).	<ul style="list-style-type: none"> <li>Demand Call - Active Low—Signal is turned on.</li> </ul>
Signal In - DTR	Specifies the DTR input signal from the port interface (when configured as DCE).	Select one: <ul style="list-style-type: none"> <li>Unused—Input signals are ignored.</li> <li>Demand Call - Active High—Signal is turned off.</li> </ul>
Signal In - DSR	Specifies the DSR input signal from the port interface (when configured as DTE).	<ul style="list-style-type: none"> <li>Demand Call - Active Low—Signal is turned on.</li> </ul>
Signal In - LL	Specifies the LL input signal from the port interface (when configured as DCE).	Select one: <ul style="list-style-type: none"> <li>Unused—Input signals are ignored.</li> <li>Demand Call - Active High—Signal is turned off.</li> </ul>
Signal In - DCD	Specifies the DCD input signal from the port interface (when configured as DTE).	<ul style="list-style-type: none"> <li>Demand Call - Active Low—Signal is turned on.</li> </ul>

## Configuring Multiservice Port Parameters for CTP Bundles (CTP Menu)

### IN THIS SECTION

- [Configuring Multiservice Audio Mode Port Parameters for CTP Bundles \(CTP Menu\) | 154](#)
- [Configuring Multiservice IRIG-B Mode Port Parameters for CTP Bundles \(CTP Menu\) | 157](#)
- [Configuring Multiservice TDC Mode Parameters for CTP Bundles \(CTP Menu\) | 160](#)
- [Configuring Multiservice 4WTO Mode Port Parameters for CTP Bundles \(CTP Menu\) | 161](#)

### Configuring Multiservice Audio Mode Port Parameters for CTP Bundles (CTP Menu)

Before you begin:

- Disable the bundle before you modify the bundle options.

To configure Multiservice audio mode port parameters using the CTP Menu:

1. From the CTP Main Menu, select **1) Bundle Operations**.
2. Select **1) CTP**.
3. Select a bundle from the list.  
If you select an active bundle, you are prompted to disable the bundle before configuring it.
4. Select **3) Port Config**.
5. Select **2) Interface**.
6. Select **1) Type**, and set the type to **Optional Interface: MultiSvc**.
7. Follow the onscreen instructions and configure the options as described in [Table 21 on page 80](#).

**Table 45: CTP Bundle Multiservice Audio Mode Port Parameter Settings in the CTP Menu**

Field	Function	Your Action
Mode	Specifies that the bundle will run in audio mode.	Select AUDIO.

Table 45: CTP Bundle Multiservice Audio Mode Port Parameter Settings in the CTP Menu (Continued)

Field	Function	Your Action
Primary/Member	<p>Specifies whether this end of the circuit provides clocking or uses adaptive clocking.</p> <p>If the CTP devices at both ends of the circuit are synchronized, you can configure both ends as Primary.</p>	<p>Select one:</p> <ul style="list-style-type: none"> <li>• Primary—This end of the circuit provides clocking.</li> <li>• Member—This end of the circuit uses adaptive clocking.</li> </ul>
Dual Channel	<p>Two channels are supported—channel 0 and channel 1.</p> <p>Enables or disables the use of both channels.</p>	<p>Select one:</p> <ul style="list-style-type: none"> <li>• Disable—Channel 0 is the only active channel.</li> <li>• Enable—Both channel 0 and channel 1 are active.</li> </ul>
Audio Sample Rate	<p>Specifies the sample rate for audio circuits in kilohertz. The sample rate determines the audio quality and the network bandwidth needed. Higher sample rates create an IP data flow that requires higher bandwidth.</p> <p>8 KHz corresponds to standard toll quality voice.</p> <p>48 KHz corresponds to CD quality audio.</p>	<p>Select one:</p> <ul style="list-style-type: none"> <li>• 8</li> <li>• 12</li> <li>• 16</li> <li>• 24</li> <li>• 32</li> <li>• 48</li> </ul>
μ-law Encoding:	<p>Enables or disables μ-law encoding. Standard audio code samples are 16 bits. If you enable μ-law encoding, the 16-bit samples are converted to 8 bits, consuming half of the bandwidth without significant audio degradation.</p>	<p>Select one:</p> <ul style="list-style-type: none"> <li>• Disable—Generates 16-bit audio samples.</li> <li>• Enable—Generates 8-bit audio samples.</li> </ul>

Table 45: CTP Bundle Multiservice Audio Mode Port Parameter Settings in the CTP Menu *(Continued)*

Field	Function	Your Action
Talk Squelch	<p>Enables or disables the active squelch function on the circuit.</p> <p>If enabled, specifies whether the squelch is active or inactive.</p> <p>The squelch function gates local audio output when DSR-A (channel 0) or RTS-A (channel 1) inputs are active or inactive.</p>	<p>Select one:</p> <ul style="list-style-type: none"> <li>• Disable—Disables the active squelch function on the circuit (audio output is always enabled).</li> <li>• Enable and active—Squelch input is grounded and analog output is disabled.</li> <li>• Enable and inactive—No signal is applied to the squelch input. Input is open and analog output is possible.</li> </ul>
Ch 0 Output Level: 1.00x (decimal 128)	<p>Specifies the output level for channel 0.</p> <p>Note the following information about the values:</p> <ul style="list-style-type: none"> <li>• 0—There is no output.</li> <li>• 128—Unity gain, which means there is no attenuation or gain.</li> <li>• 255—Gain is 2:1.</li> </ul>	Enter a number from 0 through 255.
Ch 1 Output Level: 1.00x (decimal 128)	<p>Specifies the output level for channel 1.</p> <p>Note the following information about the values:</p> <ul style="list-style-type: none"> <li>• 0—There is no output.</li> <li>• 128—Unity gain, which means there is no attenuation or gain.</li> <li>• 255—Gain is 2:1.</li> </ul>	Enter a number from 0 through 255.

**SEE ALSO**

| *Serial Multiservice Interface Module Overview*

**Configuring Multiservice IRIG-B Mode Port Parameters for CTP Bundles (CTP Menu)**

Before you begin:

- Disable the bundle before you modify the bundle options.

To configure Multiservice IRIG-B mode port parameters using the CTP Menu:

1. From the CTP Main Menu, select **1) Bundle Operations**.
2. Select **1) CTP**.
3. Select a bundle from the list.  
If you select an active bundle, you are prompted to disable the bundle before configuring it.
4. Select **3) Port Config**.
5. Select **2) Interface**.
6. Select **1) Type** and set the type to **Optional Interface: MultiSvc**.
7. Follow the onscreen instructions and configure the options as described in [Table 22 on page 83](#).

**Table 46: CTP Bundle Multiservice IRIG-B Port Parameter Settings in the CTP Menu**

Field	Function	Your Action
Mode	Specifies that the bundle will run in IRIG-B mode.	Select IRIG.

Table 46: CTP Bundle Multiservice IRIG-B Port Parameter Settings in the CTP Menu *(Continued)*

Field	Function	Your Action
Src/Dest	<p>Specifies the direction of the circuit. Although the IP circuit connection through the network is full duplex, an IRIG-B circuit is a simplex application, and the interface can operate only in Rx or Tx mode and not both at the same time.</p> <p>(Although the bundle is by default a full duplex IP connection, you can configure it for simplex to save network bandwidth.)</p>	<p>Specify yes or no to the question: Is this an IRIG-B source end (IRIG-B signal enters CTP)?</p> <ul style="list-style-type: none"> <li>• Yes (y)—Sets direction to Rx. This end of the circuit recovers IRIG-B from the attached cable and generates IP packets toward the network.</li> <li>• No (n)—Sets the direction to Tx. This end of the circuit accepts IP packets, extracts the IRIG-B data codes, and transmits IRIG-B signaling output onto the cable.</li> </ul> <p>If the autonegotiation setting of the CTP Ethernet media and the far-end switch or router do not match, it is possible for the CTP Ethernet ports to be in a half-duplex state, although the duplex setting is not configurable and always assumed to be full-duplex on the CTP device. Starting with CTPOS Release 7.2, the half-duplex state at CTP network interface card (NIC) ports are acquired, regardless of the duplex setting configured on the far-end node. After the autonegotiation process is completed, if the CTP NIC cannot acquire full-duplex mode, then the interfaces are considered to be down and a log message is recorded in both the <b>/var/log/messages</b> directory and the syslog file stating that the interface is down due to a non-full duplex condition. You are prompted to verify the cable connection, speed, and duplex</p>

Table 46: CTP Bundle Multiservice IRIG-B Port Parameter Settings in the CTP Menu *(Continued)*

Field	Function	Your Action
		settings because the NIC link might be down.
IRIG Rate	<p>Specifies the data rate on the IP connection.</p> <p>Note the following about setting the IRIG rate:</p> <ul style="list-style-type: none"> <li>• Unless network bandwidth is at a premium, we do not recommend that you change this value from the default of 16,000 bps.</li> <li>• Although the IRIG information can be transported through the network at the minimum configured rate (1000 bps), a CTP bundle running at this rate is subject to high latency.</li> </ul>	Enter a number from 1000 through 25,500 bps. The port speed must be a multiple of 100 bps.
Output High Level	<p>This setting applies only if you set the direction of the port to Tx.</p> <p>Specifies the high output level, which is measured in peak-to-peak voltage. This setting is based on a 50-ohm termination.</p>	Enter a number from 0.00 through 7.85 volts peak-to-peak.
Output Low Level	<p>This setting applies only if you set the direction of the port to Tx.</p> <p>Specifies the low output level, which is measured in peak-to-peak voltage. This setting is based on a 50-ohm termination.</p>	Enter a number from 0.00 through 7.85 volts peak-to-peak.

**SEE ALSO**

| *Serial Multiservice Interface Module Overview*

**Configuring Multiservice TDC Mode Parameters for CTP Bundles (CTP Menu)**

Before you begin:

- Disable the bundle before you modify the bundle options.

To configure Multiservice TDC mode port parameters using the CTP Menu:

1. From the CTP Main Menu, select **1) Bundle Operations**.
2. Select **1) CTP**.
3. Select a bundle from the list.  
If you select an active bundle, you are prompted to disable the bundle before configuring it.
4. Select **3) Port Config**.
5. Select **2) Interface**.
6. Select **1) Type** and set the type to **Optional Interface: MultiSvc**.
7. Follow the onscreen instructions and configure the options as described in [Table 23 on page 86](#).

**Table 47: CTP Bundle Multiservice TDC Port Parameter Settings in the CTP Menu**

Field	Function	Your Action
Mode	Specifies that the bundle will run in TDC mode.	Select TDC/IRIG.
Src/Dest	Specifies the direction of the circuit.	Select one: <ul style="list-style-type: none"> <li>• Src (signal enters CTP)—End of the circuit that receives NRZ/IRIG data.</li> <li>• Dst (signal exits CTP)—End of the circuit that sends NRZ/IRIG data toward the network.</li> </ul>
NRZ/Rate	Specifies the data rate on the IP connection.	Enter a number from 500 through 5,000,000 bps. The port speed must be a multiple of 500 bps.



Table 47: CTP Bundle Multiservice TDC Port Parameter Settings in the CTP Menu (*Continued*)

Field	Function	Your Action
IRIG Output Level	<p>Specifies the output level.</p> <p>Note the following information about the values:</p> <ul style="list-style-type: none"> <li>• 0—There is no output.</li> <li>• 128—Unity gain, which means there is no attenuation or gain.</li> <li>• 255—Gain is 2:1.</li> </ul>	Enter a number from 0 through 255.

**SEE ALSO**

| *Serial Multiservice Interface Module Overview*

**Configuring Multiservice 4WTO Mode Port Parameters for CTP Bundles (CTP Menu)**

Before you begin:

- Disable the bundle before you modify the bundle options.

To configure Multiservice 4WTO mode port parameters using the CTP Menu:

1. From the CTP Main Menu, select **1) Bundle Operations**.
2. Select **1) CTP**.
3. Select a bundle from the list. The bundle port must have a 4WTO daughter card installed.  
If you select an active bundle, you are prompted to disable the bundle before configuring it.
4. Select **3) Port Config**.
5. Select **2) Interface**.
6. Select **1) Type** and set the type to **Optional Interface: MultiSvc**.
7. Configure the options as described in [Table 24 on page 88](#).

Table 48: CTP Bundle Multiservice 4WTO Port Parameter Settings in the CTP Menu

Field	Function	Your Action
Mode	Specifies that the bundle will run in 4WTO mode.	Select 4WTO-Em.
Primary/Member	<p>Specifies whether this end of the circuit provides clocking or uses adaptive clocking.</p> <p>If the CTP devices at both ends of the circuit are synchronized, you can configure both ends as Primary.</p>	<p>Select one:</p> <ul style="list-style-type: none"> <li>• Primary—This end of the circuit provides clocking.</li> <li>• Member—This end of the circuit uses adaptive clocking.</li> </ul>
Dual Channel	<p>Two channels are supported—channel 0 and channel 1.</p> <p>Enables or disables the use of both channels.</p>	<p>Select one:</p> <ul style="list-style-type: none"> <li>• Disable—Channel 0 is the only active channel.</li> <li>• Enable—Both channel 0 and channel 1 are active.</li> </ul>
Talk Squelch	<p>Enables or disables the active squelch function on the circuit.</p> <p>If enabled, specifies whether the squelch is active or inactive.</p> <p>The squelch function gates local audio output when DSR-A (channel 0) or RTS-A (channel 1) inputs are active or inactive.</p>	<p>Select one:</p> <ul style="list-style-type: none"> <li>• Disable—Disables the active squelch function on the circuit.</li> <li>• Enable and active—Squelch input is grounded and analog output is disabled.</li> <li>• Enable and inactive—No signal is applied to the squelch input. Input is open and analog output is possible.</li> </ul>

Table 48: CTP Bundle Multiservice 4WTO Port Parameter Settings in the CTP Menu *(Continued)*

Field	Function	Your Action
Ch 0 Output Level: 1.00x (decimal 128)	<p>Specifies the output level for channel 0.</p> <p>Note the following information about the values:</p> <ul style="list-style-type: none"> <li>• 0—There is no output.</li> <li>• 128—Unity gain, which means there is no attenuation or gain.</li> <li>• 255—Gain is 2:1.</li> </ul>	Enter a number from 0 through 255.
Ch 1 Output Level: 1.00x (decimal 128)	<p>Specifies the output level for channel 1.</p> <p>Note the following information about the values:</p> <ul style="list-style-type: none"> <li>• 0—There is no output.</li> <li>• 128—Unity gain, which means there is no attenuation or gain.</li> <li>• 255—Gain is 2:1.</li> </ul>	Enter a number from 0 through 255.

**SEE ALSO**

*Serial Multiservice Interface Module Overview*

*Configuring 4WTO Daughter Cards to Interoperate with Multiservice Interface Modules (CTP Menu)*

## Configuring Serial Port Parameters for CTP Bundles (CTPView)

This topic describes how to configure port parameters for serial interfaces.

Before you begin:

- Log in to the CTPView software at least at the Net\_Admin level.

- Connect the CTPView server to the CTP device for which you want to configure bundles.

To configure serial port parameters for CTP bundles using CTPView:

1. In the side pane, select **Bundle > Configuration**.
2. Run your mouse over the **Display and Select an Existing Bundle** bar.
3. In the table of bundles, select the bundle that you want to modify.
4. Under **Port Options** configure the parameters as described in [Table 49 on page 164](#).
5. Click **Click to Submit Bundle AND Port Changes**.

**Table 49: CTP Bundle Serial Port Parameter Settings in CTPView**

Field	Function	Your Action
Port Description	Specifies a description for the port.	Enter a description of up to 64 alphanumeric characters. Do not use the following characters:  ( ; ' " ) ]
I/F Mode	Specifies that the interface is connected to a data communication equipment (DCE) device or to a data terminal equipment (DTE) device.	Select one: <ul style="list-style-type: none"> <li>• DCE—The interface is connected to a DCE device.</li> <li>• DTE—The interface is connected to a DTE device.</li> </ul>

Table 49: CTP Bundle Serial Port Parameter Settings in CTPView (Continued)

Field	Function	Your Action
Serial Encoding	<p>Specifies the serial encoding method used on this bundle.</p> <p>When you change the encoding method, the clocking configuration changes to the default configuration for the encoding method that you select.</p>	<p>Select one:</p> <ul style="list-style-type: none"> <li>• NRZ—Nonreturn to zero (NRZ) line encoding.</li> <li>• ISOCH—Isochronous encoding. Isochronous encoding does not provide or embed the clock in the data.</li> <li>• CDI—Conditioned diphase. Conditioned diphase encoding recovers and embeds the clock in the data signal. CDI encoding provides a speed of up to 4608 Kbps.</li> <li>• TDM—Additional data is interleaved with the port's serial data. This option is used on TDM/TDC high-speed ports and is available only on even-numbered ports on a CTP 2000 serial module. See "<a href="#">Configuring the High-Speed CTP Bundle for TDM/TDC Operation (CTPView)</a>" on page 171.</li> <li>• TRANS8—Extension of the TRANS encoding. Compared with TRANS encoding, which sends four signals in each direction, with TRANS8 encoding, bandwidth is doubled and eight signals can be sampled and transported. This allows signals to be sent from additional interfaces that were not supported in TRANS encoding.</li> </ul>

Table 49: CTP Bundle Serial Port Parameter Settings in CTPView *(Continued)*

Field	Function	Your Action
TDM Function	This option is used only for TDM/TDC operation. See <a href="#">"Configuring the High-Speed CTP Bundle for TDM/TDC Operation (CTPView)"</a> on page 171.	
TDM Rate	This option is used only for TDM/TDC operation. See <a href="#">"Configuring the High-Speed CTP Bundle for TDM/TDC Operation (CTPView)"</a> on page 171.	
I/F Type	<p>Specifies the electrical standard used on the serial interface.</p> <p>You can install the following optional daughter cards on a serial interface:</p> <ul style="list-style-type: none"> <li>• T1/E1 (CTP1000 and CTP2000 series)</li> <li>• 4WTO (CTP1000 and CTP2000 series)</li> <li>• IRIG-B (CTP2000 series only)</li> <li>• Multiservice Daughter Cards (CTP 2000 and CTP150 series)</li> </ul>	<p>Select one:</p> <ul style="list-style-type: none"> <li>• EIA-530</li> <li>• EIA-530A</li> <li>• RS-232</li> <li>• V.35</li> <li>• DCARD</li> <li>• OFF—Do not set the interface type to OFF.</li> </ul>

Table 49: CTP Bundle Serial Port Parameter Settings in CTPView (Continued)

Field	Function	Your Action
Port Speed	<p>Specifies the speed of the port. In networks without bandwidth constraints, we recommend a multiple of 10.</p> <p>The port speed recommendations vary according to encoding type:</p> <ul style="list-style-type: none"> <li>• For transparent mode circuits, the port speed is the sample rate for user data. Therefore, port rate should be a multiple of the user data rate.</li> <li>• For CDI circuits, the port speed is limited to 4608 KBps.</li> </ul> <p>The port speed also varies depending on hardware:</p> <ul style="list-style-type: none"> <li>• CTP2000 devices cannot have an aggregate port rate greater than 114.688 Mbps.</li> </ul>	Enter a number from 0.00100 through 12880.00000 KHz.

## Configuring Transparent Encoding for CTP Bundles (CTPView)

This topic describes how to configure transparent encoding for CTP bundles. You must configure transparent encoding on each end of the circuit.

To reduce transport latency, we recommend that you use the smallest buffer values possible for networks.

There are two modes of transparent encoding. They are Transparent 4 mode (TRANS) and Transparent 8 mode (TRANS8). TRANS8 mode is supported only on CTPOS Release 6.4 and later. It is not supported on CTPView. After you configure TRANS8 from CTPOS, you cannot reconfigure the bundle from CTPView.

This topic describes how to configure the **TRANS** encoding.

Before you begin:

- Log in to the CTPView software at least at the Net\_Admin level.
- Connect the CTPView server to the CTP device for which you want to configure bundles.

To configure transparent encoding parameters for CTP bundles using CTPView:

1. In the side pane, select **Bundle > Configuration**.
2. Run your mouse over the **Display and Select an Existing Bundle** bar.
3. In the table of bundles, select the bundle that you want to modify.
4. Under **Port Options**, set **Serial Encoding** to **TRANS**.
5. Configure the **Port Speed** and **Clock Cfg** as described in [Table 50 on page 168](#).
6. Under **Port Options**, select **Advanced Options Show** to display advanced parameters and configure the parameters as described in [Table 50 on page 168](#).
7. Click **Click to Submit Bundle AND Port Changes**.

**Table 50: CTP Bundle Transparent Encoding Parameter Settings in CTPView**

Field	Function	Your Action
User Data Rate	Specifies the sample rate for user data. The port rate should be a multiple of the user data rate.	Enter a number from 0.000250 through 256.000000 KHz.
Oversampling Multiplier	Specifies the multiplier factor for calculating the port speed. A good default multiple in networks without bandwidth constraints would be 10.	Enter an even number from 4 through 100.
Port Speed	Specifies the speed of the port. The port speed is automatically calculated as 'User Data Rate' x 'Oversampling Multiplier'.  <b>NOTE:</b> The port speed must be in the range from 0.001 through 1024.0 KHz.	-



Table 50: CTP Bundle Transparent Encoding Parameter Settings in CTPView *(Continued)*

Field	Function	Your Action
Clock Cfg	<p>Specifies the clocking method used for the transparent circuit.</p> <p>To prevent errors in transport, both ends of a circuit must be synchronized with each other. You can accomplish this by either locking each end of the circuit to a common reference or by enabling adaptive clocking at one end of a circuit.</p>	<p>Select one:</p> <ul style="list-style-type: none"> <li>• TRANS - Master End—This end of the circuit generates a clock signal and sends it to the remote end. Configure TRANS - Slave End at the remote end.</li> <li>• TRANS - Slave End—This end of the circuit uses adaptive clocking to receive the clock signal from the remote end. The client clock uses its period to determine when to sample data and how to transmit data across the link. If you specify TRANS - Slave End, the adaptive clocking configuration appears. See <a href="#">"Configuring Adaptive Clocking for CTP Bundles (CTPView)" on page 203.</a></li> <li>• Custom—The custom clocking configuration is used. See <a href="#">"Configuring Custom Clocking for CTP Bundles (CTPView)" on page 199.</a></li> </ul>
16-Bit Jitter Absorption FIFO	<p>Enables or disables the phase correction FIFO buffer. This FIFO buffer aligns the clock and data phase relationship on a TRANS encoded circuit in which the clock travels in one direction and the data travels in the opposite direction.</p> <p>Enable this FIFO buffer at one end of the circuit, but not at both ends.</p>	<p>Select one:</p> <ul style="list-style-type: none"> <li>• DISABLED</li> <li>• ENABLED</li> </ul>

Table 50: CTP Bundle Transparent Encoding Parameter Settings in CTPView *(Continued)*

Field	Function	Your Action
Invert FIFO Write Clock	Specifies whether or not to invert the FIFO buffer write clock.	Select one: <ul style="list-style-type: none"> <li>• DISABLED</li> <li>• ENABLED</li> </ul>
Invert FIFO Read Clock	Specifies whether or not to invert the FIFO read clock.	Select one: <ul style="list-style-type: none"> <li>• DISABLED</li> <li>• ENABLED</li> </ul>
Use ST Lead (instead of RTS/CTS)	<p>Specifies that the circuit uses the ST lead instead of the RTS and CTS leads to sample local SD/TT/RTS/DTR signals and forward them to the remote RD/RT/CTS/DSR signals.</p> <p>The RTS and DTR signals are subject to additional delay and jitter because they are signaling leads. On higher-speed circuits, the delay and jitter on these paths make the signal choices nonoptimal. Therefore, you can specify that the circuit uses the ST lead instead of the RTS and CTS leads, which will not have this delay and jitter.</p>	Select one: <ul style="list-style-type: none"> <li>• DISABLED</li> <li>• INPUT—Enables the ST lead and specifies that the ST lead is an input lead.</li> <li>• OUTPUT—Enables the ST lead and specifies that the ST lead is an output lead.</li> </ul>

## RELATED DOCUMENTATION

[Transparent Encoding Applications and Support Overview | 22](#)

[How Basic Transparent Encoding Works | 23](#)

[Using Phase-Correction FIFO Buffer with Transparent Encoding | 24](#)

[Using Send Timing \(ST\) Clocking for Higher Speed Circuits with Transparent Encoding | 27](#)

## Configuring Bundle Pairs for TDM/TDC Operation (CTPView)

### IN THIS SECTION

- [Configuring the High-Speed CTP Bundle for TDM/TDC Operation \(CTPView\) | 171](#)
- [Configuring the Low-Speed CTP Bundle for TDM/TDC Operation \(CTPView\) | 172](#)

The TDM/TDC feature is supported on CTP2000 serial interfaces. TDM/TDC operation requires both a low-speed bundle and a high-speed bundle. This topic describes how to configure the high-speed and low-speed bundle port options when used for TDM/TDC bundles using CTPView.

### Configuring the High-Speed CTP Bundle for TDM/TDC Operation (CTPView)

Configure the high-speed bundle on an even-numbered port.

Before you begin:

- Log in to the CTPView software at least at the Net\_Admin level.
- Connect the CTPView server to the CTP device for which you want to configure bundles.

To configure a high-speed CTP bundle for TDM/TDC operation using CTPView:

1. In the side pane, select **Bundle > Configuration**.
2. Run your mouse over the **Display and Select an Existing Bundle** bar.
3. In the table of bundles, select the bundle that you want to modify. You must configure the bundle on an even-numbered port.
4. Under **Port Options**, configure the parameters as described in [Table 51 on page 171](#) and click **Click to Submit Bundle AND Port Changes**.
5. Configure the rest of the bundle as you normally would.

**Table 51: High-Speed CTP Bundle Parameters for TDM/TDC Operation in CTPView**

Field	Function	Your Action
Serial Encoding	Specifies the serial encoding method used on this bundle.	Specify TDM as the encoding method.

Table 51: High-Speed CTP Bundle Parameters for TDM/TDC Operation in CTPView *(Continued)*

Field	Function	Your Action
TDM Function	<p>Specifies the TDM function. Currently, only one TDM function is supported.</p> <p>This option is available only on even-numbered ports on a CTP2000 serial module, and when the serial encoding parameter is set to TDM.</p>	<p>Select the following:</p> <p>TDC Clk/Data on port N+1—Oversamples the incoming clock (TT) and data (SD) from the adjacent port above this one (N+1) at this port's clock rate, and embeds it in its data. At the remote end of the network, the embedded circuit data is recovered and exits the node on port N+1 as RT and RD outputs.</p> <p>Because of the direct interleaving of two ports' data, TDC is maintained between these two ports with an accuracy of one bit time at this port's data rate.</p>
TDM Rate	<p>Specifies the number of bits out of 32 that are used for the TDM function (and not for local serial port data).</p> <p>Keep in mind the following when you configure the TDM rate:</p> <ul style="list-style-type: none"> <li>• If the rate is too low, the bundle may not carry the low-speed data because of insufficient oversampling.</li> <li>• If the rate is too high, the low-speed circuit will still run, but will likely use more bandwidth than necessary.</li> <li>• You may want to configure a higher rate to increase the TDM rate to reduce jitter on the low-speed clock and data signals.</li> </ul>	<p>Select one:</p> <ul style="list-style-type: none"> <li>• 16</li> <li>• 8</li> <li>• 4</li> <li>• 2</li> </ul>

### Configuring the Low-Speed CTP Bundle for TDM/TDC Operation (CTPView)

Configure the low-speed bundle on an odd-numbered port that is one port higher than the corresponding high-speed bundle.

Before you begin:

- Log in to the CTPView software at least at the Net\_Admin level.

- Connect the CTPView server to the CTP device for which you want to configure bundles.

To configure the low-speed CTP bundle using CTPView:

1. In the side pane, select **Bundle > Configuration**.
2. Run your mouse over the **Display and Select an Existing Bundle** bar.
3. In the table of bundles, select the bundle that you want to modify.
4. Set the **Clock Cfg** to **TDM/TDC Interleaved Slow Port**.

**NOTE:** Do not configure any other bundle parameters.

## RELATED DOCUMENTATION

| [TDM/TDC Encoding Overview](#) | 30

## Configuring T1 and E1 Port Parameters for CTP Bundles (CTPView)

This topic describes how to configure port parameters for T1/E1 interfaces.

Before you begin:

- Log in to the CTPView software at least at the Net\_Admin level.
- Connect the CTPView server to the CTP device for which you want to configure bundles.

To configure T1 and E1 port parameters for CTP bundles using CTPView:

1. In the side pane, select **Bundle > Configuration**.
2. Run your mouse over the **Display and Select an Existing Bundle** bar.
3. In the table of bundles, select the bundle that you want to modify.
4. Under **Port Options**, configure the parameters as described in [Table 52 on page 174](#).

The options vary depending on whether the bundle is T1 or E1 and whether fractional T1 or E1 is configured.

5. Click **Click to Submit Bundle AND Port Changes**.

Table 52: CTP Bundle T1 and E1 Port Parameter Settings in CTPView

Field	Function	Your Action
Port Description	Specifies a description for the port.	Enter a description of up to 64 alphanumeric characters. Do not use the following characters:  ( ; ' " ) ]
I/F Type	Specifies the daughter card as the interface type.	Select DCARD.
T1/E1 Choice	Specifies the type of interface.	Select one: <ul style="list-style-type: none"> <li>• T1</li> <li>• E1</li> </ul>
Fractional	Specifies whether the card is fractional.	Select one: <ul style="list-style-type: none"> <li>• DISABLED—Card is not fractional.</li> <li>• ENABLED—Card is fractional.</li> </ul>
T1 Line Coding	For T1 interfaces, specifies the T1 encoding method used on this bundle.	Select one: <ul style="list-style-type: none"> <li>• B8ZS</li> <li>• AMI</li> </ul>
Framing Mode	For fractional T1, ESF is the only option supported.  With ESF framing, the frame synchronization, data link, and CRC framing bits are passed across the IP network untouched.	

Table 52: CTP Bundle T1 and E1 Port Parameter Settings in CTPView *(Continued)*

Field	Function	Your Action
Fractional Frame Transport	For fractional T1, enable or disable fractional frame transport.	Select one: <ul style="list-style-type: none"> <li>• Frame Transport—Framing bit is transported along with data, which results in data alignment with the frame.</li> <li>• No Frame Transport—Framing bit is not transported.</li> </ul>
E1 Connector Type	For E1 interfaces, configure the termination to work with either coaxial or RJ-48.	Select one: <ul style="list-style-type: none"> <li>• RJ48</li> <li>• COAX</li> </ul>
Number of Channels	Specifies the number of fractional T1 or E1 channels to transport.	For T1, select a number from 1 through 24.  For E1, select a number from 1 through 31.
Signaling	Specifies the signaling method used for fractional E1.	Select one: <ul style="list-style-type: none"> <li>• CSS—Common Channel Signaling. The common channel carries data messages that convey signaling for the circuits between two devices.</li> <li>• CAS—Channel associated signaling. Each traffic channel has a dedicated signaling channel (channel 16).</li> </ul>

Table 52: CTP Bundle T1 and E1 Port Parameter Settings in CTPView *(Continued)*

Field	Function	Your Action
Clock Cfg	Specifies the type of clocking for the port. The default value for Clock Cfg is <b>CTP is Loop Timed</b> .	<p>Select one:</p> <ul style="list-style-type: none"> <li>• CTP is Clock Source—The PBX either returns the clock received from the CTP device, or it returns a clock that is traceable to the same source as the CTP node clock reference. You typically use this configuration when you configure the CTP device with a clock reference input.</li> <li>• CTP is Loop Timed—The PBX provides the clock, and the CTP device returns the same clock to the PBX. You typically use this configuration when the PBX has the more accurate clock source. You can configure the far end of the circuit with adaptive clocking to recover this clock if necessary.</li> <li>• CTP is Clock Source - Adap—The PBX returns the clock received from the CTP device, and the CTP device uses the adaptive recovered clock. You typically use this configuration when the CTP device does not have a reference input and the PBX typically requires a clock from the distant PBX.</li> </ul>



## Configuring Multiservice Port Parameters for CTP Bundles (CTPView)

### IN THIS SECTION

- [Configuring Multiservice Audio Mode Port Parameters for CTP Bundles \(CTPView\) | 177](#)
- [Configuring Multiservice IRIG-B Mode Port Parameters for CTP Bundles \(CTPView\) | 180](#)
- [Configuring Multiservice TDC Mode Parameters for CTP Bundles \(CTPView\) | 182](#)
- [Configuring Multiservice 4WTO Mode Port Parameters for CTP Bundles \(CTPView\) | 183](#)

### Configuring Multiservice Audio Mode Port Parameters for CTP Bundles (CTPView)

Before you begin:

- Log in to the CTPView software at least at the Net\_Admin level.
- Connect the CTPView server to the CTP device for which you want to configure bundles.

To configure Multiservice audio mode port parameters using CTPView:

1. In the side pane, select **Bundle > Configuration**.
2. Run your mouse over the **Display and Select an Existing Bundle** bar.
3. In the table of bundles, select the bundle that you want to modify.
4. Under **Bundle Options**, configure the parameters as described in [Table 13 on page 56](#) and click **Click to Submit Bundle AND Port Changes**.

**Table 53: CTP Bundle Multiservice Audio Port Parameter Settings in CTPView**

Field	Function	Your Action
Port Description	Specifies a description for the port.	Enter a description of up to 64 alphanumeric characters. Do not use the following characters:  ( ; ' " ) ]
I/F Type	Specifies the daughter card as the interface type.	Select DCARD.

Table 53: CTP Bundle Multiservice Audio Port Parameter Settings in CTPView (Continued)

Field	Function	Your Action
Multi-Service Mode	Specifies that the bundle will run in audio mode.	Select Audio.
Audio Mode	<p>Specifies whether this end of the circuit provides clocking or uses adaptive clocking.</p> <p>If the CTP devices at both ends of the circuit are synchronized, you can configure both ends as Primary.</p>	<p>Select one:</p> <ul style="list-style-type: none"> <li>• Primary—This end of the circuit provides clocking.</li> <li>• Member—This end of the circuit uses adaptive clocking.</li> </ul>
Audio Channel	Specifies the channel or channels to enable.	<p>Select one:</p> <ul style="list-style-type: none"> <li>• Channel 0—Enables only channel 0.</li> <li>• Dual Channel—Enables both channel 0 and channel 1.</li> </ul>
Audio Sample Rate [ KHz ]	<p>Specifies the sample rate for audio circuits in kilohertz. The sample rate determines the audio quality and the network bandwidth needed. Higher sample rates create an IP data flow that requires higher bandwidth.</p> <p>8 KHz corresponds to standard toll quality voice.</p> <p>48 KHz corresponds to CD quality audio.</p>	<p>Select one:</p> <ul style="list-style-type: none"> <li>• 8</li> <li>• 12</li> <li>• 16</li> <li>• 24</li> <li>• 32</li> <li>• 48</li> </ul>
Audio $\mu$ -law Encoding	Enables or disables $\mu$ -law encoding. Standard audio code samples are 16 bits. If you enable $\mu$ -law encoding, the 16-bit samples are converted to 8 bits, consuming half of the bandwidth without significant audio degradation.	<p>Select one:</p> <ul style="list-style-type: none"> <li>• DISABLED (16 bit samples)—Generates 16-bit audio samples.</li> <li>• ENABLED (8 bit samples)—Generates 8-bit audio samples.</li> </ul>

Table 53: CTP Bundle Multiservice Audio Port Parameter Settings in CTPView (*Continued*)

Field	Function	Your Action
Audio Squelch	<p>Enables or disables the active squelch function on the circuit.</p> <p>If enabled, specifies whether the squelch is active or inactive.</p> <p>The squelch function gates local audio output when DSR-A (channel 0) or RTS-A (channel 1) inputs are active or inactive.</p>	<p>Select one:</p> <ul style="list-style-type: none"> <li>• <b>DISABLED</b>—Disables the active squelch function on the circuit (audio output is always enabled).</li> <li>• <b>ENABLED/ACTIVE</b>—Squelch input is grounded and analog output is disabled.</li> <li>• <b>ENABLED/INACTIVE</b>—No signal is applied to the squelch input. Input is open and analog output is possible.</li> </ul>
Audio Channel 0 Output Level	<p>Specifies the output level for channel 0.</p> <p>Note the following information about the values:</p> <ul style="list-style-type: none"> <li>• 0—There is no output.</li> <li>• 128—Unity gain, which means there is no attenuation or gain.</li> <li>• 255—Gain is 2:1.</li> </ul>	Enter a number from 0 through 255.
Audio Channel 1 Output Level	<p>Specifies the output level for channel 1.</p> <p>Note the following information about the values:</p> <ul style="list-style-type: none"> <li>• 0—There is no output.</li> <li>• 128—Unity gain, which means there is no attenuation or gain.</li> <li>• 255—Gain is 2:1.</li> </ul>	Enter a number from 0 through 255.

**SEE ALSO**

| *Serial Multiservice Interface Module Overview*

## Configuring Multiservice IRIG-B Mode Port Parameters for CTP Bundles (CTPView)

Before you begin:

- Log in to the CTPView software at least at the Net\_Admin level.
- Connect the CTPView server to the CTP device for which you want to configure bundles.

To configure Multiservice IRIG-B mode port parameters using CTPView:

1. In the side pane, select **Bundle > Configuration**.
2. Run your mouse over the **Display and Select an Existing Bundle** bar.
3. In the table of bundles, select the bundle that you want to modify.
4. Under **Bundle Options**, configure the parameters as described in [Table 14 on page 59](#) and click **Click to Submit Bundle AND Port Changes**.

**Table 54: CTP Bundle Multiservice IRIG-B Port Parameter Settings in CTPView**

Field	Function	Your Action
Port Description	Specifies a description for the port.	Enter a description of up to 64 alphanumeric characters. Do not use the following characters:  ( ; ' " ) ]
I/F Type	Specifies the daughter card as the interface type.	Select DCARD.
Multi-Service Mode	Specifies that the bundle will run in IRIG-B mode.	Select IRIG-B.

Table 54: CTP Bundle Multiservice IRIG-B Port Parameter Settings in CTPView (Continued)

Field	Function	Your Action
IRIG-B Source	<p>Specifies the direction of the circuit. Although the IP circuit connection through the network is full duplex, an IRIG-B circuit is a simplex application, and the interface can operate only in Rx or Tx mode and not both at the same time.</p> <p>(Although the bundle is by default a full duplex IP connection, you can configure it for simplex to save network bandwidth.)</p> <p>If the autonegotiation setting of the CTP Ethernet media and the far-end switch or router do not match, it is possible for the CTP Ethernet ports to be in a half-duplex state, although the duplex setting is not configurable and always assumed to be full-duplex on the CTP device. Starting with CTPOS Release 7.2, the half-duplex state at CTP network interface card (NIC) ports are acquired, regardless of the duplex setting configured on the far-end node. After the autonegotiation process is completed, if the CTP NIC cannot acquire full-duplex mode, then the interfaces are considered to be down and a log message is recorded in both the <code>/var/log/messages</code> directory and the syslog file stating that the interface is down due to a non-full duplex condition. You are prompted to verify the cable connection, speed, and duplex settings because the NIC link might be down.</p>	<p>Select one:</p> <ul style="list-style-type: none"> <li>• TX (signal enters CTP)—The end of the circuit that accepts IP packets, extracts the IRIG-B data codes, and transmits IRIG-B signaling output onto the cable.</li> <li>• RX (signal exits CTP)—The end of the circuit that recovers IRIG-B from the attached cable and generates IP packets toward the network.</li> </ul>
IRIG-B Data Rate	<p>Specifies the data rate on the IP connection.</p> <p>Note the following about setting the IRIG rate:</p> <ul style="list-style-type: none"> <li>• Unless network bandwidth is at a premium, we do not recommend that you change this value from the default of 16,000 bps.</li> <li>• Although the IRIG information can be transported through the network at the minimum configured rate (1000 bps), a CTP bundle running at this rate is subject to high latency.</li> </ul>	<p>Enter a number from 1000 through 25,500 bps. The port speed must be a multiple of 100 bps.</p>
Output High Volts Level	<p>This option appears only if you set the direction of the port to Tx.</p> <p>Specifies the high output level, which is measured in peak-to-peak voltage. This setting is based on a 50-ohm termination</p>	<p>Enter a number from 0.00 through 7.85 volts peak-to-peak.</p>

Table 54: CTP Bundle Multiservice IRIG-B Port Parameter Settings in CTPView (Continued)

Field	Function	Your Action
Output Low Volts Level	This option appears only if you set the direction of the port to Tx.  Specifies the low output level, which is measured in peak-to-peak voltage. This setting is based on a 50-ohm termination.	Enter a number from 0.00 through 7.85 volts peak-to-peak.

**SEE ALSO**

| *Serial Multiservice Interface Module Overview*

**Configuring Multiservice TDC Mode Parameters for CTP Bundles (CTPView)**

Before you begin:

- Log in to the CTPView software at least at the Net\_Admin level.
- Connect the CTPView server to the CTP device for which you want to configure bundles.

To configure Multiservice TDC mode port parameters using CTPView:

1. In the side pane, select **Bundle > Configuration**.
2. Run your mouse over the **Display and Select an Existing Bundle** bar.
3. In the table of bundles, select the bundle that you want to modify.
4. Under **Bundle Options**, configure the parameters as described in [Table 15 on page 61](#) and click **Click to Submit Bundle AND Port Changes**.

Table 55: CTP Bundle Multiservice TDC Port Parameter Settings in CTPView

Field	Function	Your Action
Port Description	Specifies a description for the port.	Enter a description of up to 64 alphanumeric characters. Do not use the following characters:  ( ; ' " ) ]

Table 55: CTP Bundle Multiservice TDC Port Parameter Settings in CTPView (Continued)

Field	Function	Your Action
I/F Type	Specifies the daughter card as the interface type.	Select DCARD.
Multi-Service Mode	Specifies that the bundle will run in TDC mode.	Select TDC.
TDC Source	Specifies the direction of the circuit.	Select one: <ul style="list-style-type: none"> <li>• Source (signal enters CTP)—End of the circuit that receives NRZ/IRIG data.</li> <li>• Destination (signal exits CTP)—End of the circuit that sends NRZ/IRIG data toward the network.</li> </ul>
TDC NRZ Rate	Specifies the NRZ data rate on the IP connection.	Enter a number from 500 through 5,000,000 bps in multiples of 500.
TDC IRIG Output Level	Specifies the output level.  Note the following information about the values: <ul style="list-style-type: none"> <li>• 0—There is no output.</li> <li>• 128—Unity gain, which means there is no attenuation or gain.</li> <li>• 255—Gain is 2:1.</li> </ul>	Enter a number from 0 through 255.

**SEE ALSO**

| *Serial Multiservice Interface Module Overview*

**Configuring Multiservice 4WTO Mode Port Parameters for CTP Bundles (CTPView)**

Before you begin:

- Log in to the CTPView software at least at the Net\_Admin level.

- Connect the CTPView server to the CTP device for which you want to configure bundles.

To configure Multiservice 4WTO mode port parameters using CTPView:

1. In the side pane, select **Bundle > Configuration**.
2. Run your mouse over the **Display and Select an Existing Bundle** bar.
3. In the table of bundles, select the bundle that you want to modify.
4. Under **Bundle Options**, configure the parameters as described in [Table 16 on page 63](#).
5. Click **Click to Submit Bundle AND Port Changes**.

**Table 56: CTP Bundle Multiservice 4WTO Mode Port Parameter Settings in CTPView**

Field	Function	Your Action
Port Description	Specifies a description for the port.	Enter a description of up to 64 alphanumeric characters. Do not use the following characters:  ( ; ' " ) ]
I/F Type	Specifies the daughter card as the interface type.	Select DCARD.
Multi-Service Mode	Specifies that the bundle will run in 4WTO mode.	Select 4WTO
4WTO Mode	Specifies whether this end of the circuit provides clocking or uses adaptive clocking.  If the CTP devices at both ends of the circuit are synchronized, you can configure both ends as Primary.	Select one: <ul style="list-style-type: none"> <li>• Primary—This end of the circuit provides clocking.</li> <li>• Member—This end of the circuit uses adaptive clocking.</li> </ul>
4WTO Channel	Specifies the channel or channels to enable.  Each CTP bundle can support either one or two channels.	Select one: <ul style="list-style-type: none"> <li>• Channel 0—Enables only channel 0.</li> <li>• Dual Channel—Enables both channel 0 and channel 1.</li> </ul>



Table 56: CTP Bundle Multiservice 4WTO Mode Port Parameter Settings in CTPView (Continued)

Field	Function	Your Action
4WTO Sample Rate [ KHz ]	Sample rate for audio circuits in kilohertz. The sample rate determines the audio quality and the network bandwidth needed.	Sample rate is fixed at 8 KHz, which corresponds to standard toll quality voice.
4WTO $\mu$ -law Encoding	4WTO $\mu$ -law encoding is not configurable.	4WTO $\mu$ -law encoding is fixed at DISABLED.
4WTO Squelch	<p>Enables or disables the active squelch function on the circuit.</p> <p>If enabled, specifies whether the squelch is active or inactive.</p> <p>The squelch function gates local audio output when DSR-A (channel 0) or RTS-A (channel 1) inputs are active or inactive.</p>	<p>Select one:</p> <ul style="list-style-type: none"> <li>• DISABLED—Disables the active squelch function on the circuit</li> <li>• ENABLED/ACTIVE—Squelch input is grounded and analog output is disabled.</li> <li>• ENABLED/INACTIVE—No signal is applied to the squelch input. Input is open and analog output is possible.</li> </ul>
4WTO Channel 0 Output Level	<p>Specifies the output level for channel 0.</p> <p>Note the following information about the values:</p> <ul style="list-style-type: none"> <li>• 0—There is no output.</li> <li>• 128—Unity gain, which means there is no attenuation or gain.</li> <li>• 255—Gain is 2:1.</li> </ul>	Enter a number from 0 through 255.

Table 56: CTP Bundle Multiservice 4WTO Mode Port Parameter Settings in CTPView *(Continued)*

Field	Function	Your Action
4WTO Channel 1 Output Level	<p>Specifies the output level for channel 1.</p> <p>Note the following information about the values:</p> <ul style="list-style-type: none"> <li>• 0—There is no output.</li> <li>• 128—Unity gain, which means there is no attenuation or gain.</li> <li>• 255—Gain is 2:1.</li> </ul>	Enter a number from 0 through 255.

**SEE ALSO**

*Serial Multiservice Interface Module Overview*

[Configuring 4WTO Port Parameters for CTP Bundles \(CTPView\) | 186](#)

## Configuring 4WTO Port Parameters for CTP Bundles (CTPView)

For CTP bundles, you can configure a 4WTO daughter card installed on a serial interface module.

You can set up 4WTO daughter cards to interoperate with Multiservice Interface modules.

Interoperability of Multiservice Interface modules with 4WTO daughter cards requires the following:

- Firmware revision 4 or later on the 4WTO daughter card.
- CTPView releases 3.4R4 or 4.x.
- CTPOS release 6.0 or later.
- Channel 1 cannot be configured as the channel option.

Before you begin:

- Log in to the CTPView software at least at the Net\_Admin level.
- Connect the CTPView server to the CTP device for which you want to configure bundles.

To configure port parameters for 4WTO daughter cards for CTP bundles using CTPView:

1. In the side pane, select **Bundle > Configuration**.
2. Run your mouse over the **Display and Select an Existing Bundle** bar.
3. In the table of bundles, select the bundle that you want to modify.
4. Under **Port Options**, configure the parameters as described in [Table 57 on page 187](#).
5. Click **Click to Submit Bundle AND Port Changes**.

**Table 57: CTP Bundle 4WTO Port Parameter Settings in CTPView**

Field	Function	Your Action
Port Description	Specifies a description for the port.	Enter a description of up to 64 alphanumeric characters. Do not use the following characters:  ( ; ' " ) ]
I/F Mode	Specifies that the interface is connected to a data communication equipment (DCE) device.	Select DCE.
I/F Type	Specifies the daughter card as the interface type.	Select DCARD.
Channel Options	Specifies the voice channel or channels to enable on the 4WTO daughter card.  Each CTP port with the daughter card installed can support either one or two channels.	Select one: <ul style="list-style-type: none"> <li>• Channel 0—Enables only channel 0.</li> <li>• Channel 1—Enables only channel 1.</li> <li>• Dual Channel—Enables both channel 0 and channel 1.</li> </ul>

Table 57: CTP Bundle 4WTO Port Parameter Settings in CTPView *(Continued)*

Field	Function	Your Action
Output Level	<p>Specifies the output level for the 4WTO daughter card.</p> <p>Note the following information about the values:</p> <ul style="list-style-type: none"> <li>• 0—Gain is 2:3 (signal is attenuated 33% or 1.8 dB).</li> <li>• 25—Unity gain, which means there is no attenuation or gain.</li> <li>• 255—Gain is 4:1 (signal is amplified 400% or 6 dB).</li> </ul> <p>Intermediate values are derived with linear interpolation. The actual gain depends on the impedance of the attached device.</p>	Enter a number from 0 through 255.

Table 57: CTP Bundle 4WTO Port Parameter Settings in CTPView (Continued)

Field	Function	Your Action
Input Level	<p>Specifies the input level for the 4WTO daughter card.</p> <p>Note the following information about the values:</p> <ul style="list-style-type: none"> <li>• 0—Setting the value to 0 attenuates the signal 33% (1.8 dB).</li> <li>• 25—This is the default and the unity value (no attenuation or gain).</li> <li>• 255—Setting the value to 255 amplifies the signal 400% (6 dB).</li> </ul> <p>Note the following information about the values:</p> <ul style="list-style-type: none"> <li>• 0—Gain is 2:3 (signal is attenuated 33% or 1.8 dB).</li> <li>• 25—Unity gain, which means there is no attenuation or gain.</li> <li>• 255—Gain is 4:1 (signal is amplified 400% or 6 dB).</li> </ul> <p>Intermediate values are derived with linear interpolation. The actual gain depends on the impedance of the attached device.</p>	Enter a number from 0 through 255.
Port Speed		Enter a number from 0.00100 through 12880.00000 KHz.

Table 57: CTP Bundle 4WTO Port Parameter Settings in CTPView (Continued)

Field	Function	Your Action
Talk Squelch	<p>Enables or disables the active squelch function on the circuit.</p> <p>If enabled, specifies whether the squelch is active or inactive.</p> <p>The squelch function gates local audio output when DSR-A (channel 1) or RTS-A (channel 0) inputs are active or inactive.</p>	<p>Select one:</p> <ul style="list-style-type: none"> <li>• DISABLED—Disables the active squelch function on the circuit</li> <li>• ENABLED/ACTIVE—Squelch input is grounded and analog output is disabled.</li> <li>• ENABLED/INACTIVE—No signal is applied to the squelch input. Input is open and analog output is possible.</li> </ul>
MS Interwork	<p>Enables or disables interoperability of the 4WTO daughter card with Multiservice Interface modules.</p> <p>When you enable interoperability of the 4WTO daughter card with Multiservice Interface modules, the port speed for the bundle is set as follows:</p> <ul style="list-style-type: none"> <li>• 64 when only channel 0 is enabled.</li> <li>• 128 when dual channel is enabled.</li> </ul>	<ul style="list-style-type: none"> <li>• ENABLED—Interoperability with the Multiservice Interface module is enabled.</li> <li>• DISABLED—Interoperability with the Multiservice Interface module is disabled.</li> </ul>

Table 57: CTP Bundle 4WTO Port Parameter Settings in CTPView (Continued)

Field	Function	Your Action
Clock Cfg	<p>Specifies the type of clocking for the port.</p> <p>To prevent voice channels from generating occasional noise bursts caused by unsynchronized nodes, we recommend that you configure one end of the voice port (not both) for adaptive clocking or lock both ends to clock references.</p>	<p>Select one:</p> <ul style="list-style-type: none"> <li>• Custom—Custom clocking configuration is used.</li> <li>• Voice/IRIG-B Master End—This end of the circuit generates a clock signal and sends it to the remote end.</li> <li>• Voice/IRIG-B Slave End—This end of the circuit receives the clock signal from the remote end. The client clock uses its period to determine when to sample data and how to transmit data across the link.</li> </ul>

## RELATED DOCUMENTATION

[Configuring Multiservice 4WTO Mode Port Parameters for CTP Bundles \(CTPView\)](#) | 62

## Configuring IRIG-B Port Parameters for CTP Bundles (CTPView)

This topic describes how to configure port parameters for IRIG-B daughter cards.

Adaptive clocking is configured by default on IRIG-B bundles, and the packet size is set to 64 bytes. The packet size combined with the default data rate of 16 Kbps produces a packet rate of 32 pps, which is a good packet rate for adaptive clocking.

Before you begin:

- Log in to the CTPView software at least at the Net\_Admin level.
- Connect the CTPView server to the CTP device for which you want to configure bundles.

To configure IRIG-B port parameters using CTPView:

1. In the side pane, select **Bundle > Configuration**.

2. Run your mouse over the **Display and Select an Existing Bundle** bar.
3. In the table of bundles, select the bundle that you want to modify.
4. Under **Bundle Options**, configure the parameters as described in [Table 58 on page 192](#) and click **Click to Submit Bundle AND Port Changes**.

**Table 58: CTP Bundle IRIG-B Port Parameter Settings in CTPView**

Field	Function	Your Action
Port Description	Specifies a description for the port.	Enter a description of up to 64 alphanumeric characters. Do not use the following characters:  ( ; ' " ) ]
I/F Type	Specifies the daughter card as the interface type.	Select DCARD.
Port Speed	Specifies the data rate on the IP connection.  Unless network bandwidth is at a premium, we do not recommend that you change this value from the default of 16,000 bps.	Enter a number from 1.000 through 25.500 KHz. The port speed must be a multiple of 100 bps.



Table 58: CTP Bundle IRIG-B Port Parameter Settings in CTPView (Continued)

Field	Function	Your Action
Direction	<p>Specifies the direction of the circuit. Although the IP circuit connection through the network is full duplex, an IRIG-B circuit is actually a simplex application, and the daughter card can operate only in Rx or Tx mode and not both at the same time.</p> <p>If the autonegotiation setting of the CTP Ethernet media and the far-end switch or router do not match, it is possible for the CTP Ethernet ports to be in a half-duplex state, although the duplex setting is not configurable and always assumed to be full-duplex on the CTP device. Starting with CTPOS Release 7.2, the half-duplex state at CTP network interface card (NIC) ports are acquired, regardless of the duplex setting configured on the far-end node. After the autonegotiation process is completed, if the CTP NIC cannot acquire full-duplex mode, then the interfaces are considered to be down and a log message is recorded in both the <code>/var/log/messages</code> directory and the syslog file stating that the interface is down due to a non-full duplex condition. You are prompted to verify the cable connection, speed, and duplex settings because the NIC link might be down.</p>	<p>Select one:</p> <ul style="list-style-type: none"> <li>• RX—The end of the circuit that recovers IRIG-B from the attached cable and generates IP packets toward the network.</li> <li>• TX—The end of the circuit that accepts IP packets, extracts the IRIG-B data codes, and transmits IRIG-B signaling output onto the cable.</li> </ul>
Output High Volts Level	<p>This option appears only if you set the direction of the port to Tx.</p> <p>Specifies the high output level, which is measured in peak-to-peak voltage. This setting is based on a 50-ohm termination</p>	<p>Enter a number from 0.00 through 7.85 volts peak-to-peak.</p>
Output Low Volts Level	<p>This option appears only if you set the direction of the port to Tx.</p> <p>Specifies the low output level, which is measured in peak-to-peak voltage. This setting is based on a 50-ohm termination.</p>	<p>Enter a number from 0.00 through 7.85 volts peak-to-peak.</p>

Table 58: CTP Bundle IRIG-B Port Parameter Settings in CTPView (Continued)

Field	Function	Your Action
Clock Cfg	Specifies the type of clocking for the bundle.	<p>Select one:</p> <ul style="list-style-type: none"> <li>• Custom—The custom clocking configuration is used.</li> <li>• Voice/IRIG-B Master End—This end of the circuit generates a clock signal and sends it to the remote end.</li> <li>• Voice/IRIG-B Slave End—This end of the circuit receives the clock signal from the remote end. The client clock uses its period to determine when to sample data and how to transmit data across the link.</li> </ul>

## Configuring Advanced Port Options for CTP Bundles (CTPView)

Before you begin:

- Log in to the CTPView software at least at the Net\_Admin level.
- Connect the CTPView server to the CTP device for which you want to configure bundles.

To configure advanced port options for CTP bundles using CTPView:

1. In the side pane, select **Bundle > Configuration**.
2. Run your mouse over the **Display and Select an Existing Bundle** bar.
3. In the table of bundles, select the bundle that you want to modify.
4. Under **Port Options**, select the **Advanced Options Show** to display advanced parameters and configure the parameters as described in [Table 59 on page 195](#).
5. Click **Click to Submit Bundle AND Port Changes**.

Table 59: CTP Bundle Advanced Port Options Settings in CTPView

Field	Function	Your Action
Single Ended Data/Clock Output	Do not change this value without consulting JTAC.  Specifies whether or not the CTP device drives received data (RD) onto data set ready (DSR) and real-time (RT) data onto test mode (TM).	Select ENABLED or DISABLED.
Reclock to Align Clock and Data	Do not change this value without consulting JTAC.  Specifies whether or not to reclock RD with the RT clock to align the data and the clock.	Select ENABLED or DISABLED.
Only High TT Checking	Specifies that the CTP device disqualifies transmit timing (TT) only when it is higher than the port speed.  When enabled, this setting keeps the port from going to the TtFail state when the incoming user clock fluctuates between 0 and the configured port rate. If the TT rate goes above the configured port rate, the CTP device sends the port to the TtFail state to protect the system from an overspeed TT, which would cause problems for the port, CTP device, or network.	Select ENABLED or DISABLED.
TT Clock Gated by RTS	When request to send (RTS) is inactive, specifies whether or not the CTP device feeds TT with the internally created clock.	Select ENABLED or DISABLED.
RTS Clock Gated Invert	When clock gating is enabled, specifies whether or not to use the inverted RTS signal.	Select ENABLED or DISABLED.
Input/Output Data Inversion	Specifies whether or not to invert data bound for the interface with data bound for the IP network.	Select ENABLED or DISABLED.
Substitute DDS when TT gone	Helps maintain the low-speed port on a TDM/TDC CTP serial circuit at up when the high-speed circuit goes down.	Select ENABLED or DISABLED.
LOS checking (T1E1 only)	Specifies whether you want to enable or disable loss of signal (LOS) detection for CTP bundles in a T1/E1 both-ended Y cable configuration (hardware-based redundancy or software-based Y cable link protocol).	Select <b>Yes</b> or <b>No</b> .

Table 59: CTP Bundle Advanced Port Options Settings in CTPView (Continued)

Field	Function	Your Action
SD activity for RTS	<p>Specifies whether to replace the incoming RTS indicator with the state of the incoming send data (SD) activity monitor.</p> <p>When disabled, the logic value of incoming RTS signal determines the state of the RTS indicator. When enabled, the presence (or absence) of incoming data transitions determines the state of the RTS indicator. This capability allows SD activity to be used to determine the state of demand CTP bundles.</p>	Select <b>Yes</b> or <b>No</b> .

## Selecting the Type of Clocking on Serial Ports for CTP Bundles (CTPView)

This topic describes how to select the type of clocking that you want to use on serial ports. The type of clocking supported depends on the type of encoding you are using.

Before you begin:

- Log in to the CTPView software at least at the Net\_Admin level.
- Connect the CTPView server to the CTP device for which you want to configure bundles.

To specify the clocking type for CTP bundles using CTPView:

1. In the side pane, select **Bundle > Configuration**.
2. Run your mouse over the **Display and Select an Existing Bundle** bar.
3. In the table of bundles, select the bundle that you want to modify.
4. Under **Port Options**, select a clocking type in the **Clock Cfg** field. [Table 60 on page 197](#) describes the clocking types that are supported for each encoding type.
5. Click **Click to Submit Bundle AND Port Changes**.

Table 60: Clocking Type Supported for Each Encoding Type as Displayed in CTPView

Encoding Type	Clocking Type Supported
NRZ and TDM with interface mode set to DCE.	<p>You can specify the following clocking methods for NRZ and TDM circuits with DCE mode specified:</p> <ul style="list-style-type: none"> <li>• Cfg Rate - Int Clk—Configured rate without external TX clock (TT). The CTP device synthesizes the rate that is used on the ST and RT outputs to the attached device. The ST is used to sample Send Data from the attached DTE. The clock is created by the CTP DDS circuitry and logic. This option is commonly used on circuits that are less than 1 Mbps.</li> <li>• Cfg Rate - Ext Clk—Configured rate with external TX clock (TT). The CTP device synthesizes the rate that is used on the ST and RT outputs to the attached device. The clock is created by the DDS circuitry and logic. This option is used to sample Send Data from the attached device. It assumes that the attached device is using ST or clock reference that is traceable to CTP reference. It is typically used for higher data rates (&gt;1 Mbps) and long cables.</li> <li>• All Clock - Ext Clk—All clocked with external TX clock (TT). The CTP clock uses the external TT timing from the DTE for all clocking. Ext TT is used to sample Send Data from the attached device, to generate the RT clock, and to clock data into the IP network.</li> <li>• Adap Rate - Ext Clk—Adaptive clocking with external TX clock (TT).</li> <li>• Adap Rate - Int Clk—Adaptive clocking with internal clock.</li> <li>• Auto Rate - Int Clk—Autobaud rate with internal clock.</li> <li>• Auto Rate - Ext Clk—Autobaud rate with external clock.</li> <li>• TDM/TDC Interleaved Slow Port—Available only on odd-numbered ports. Use this option for the low-speed port of a time domain correlation (TDC) circuit.</li> <li>• Custom—The custom clocking configuration is used.</li> </ul>

Table 60: Clocking Type Supported for Each Encoding Type as Displayed in CTPView (Continued)

Encoding Type	Clocking Type Supported
NRZ and TDM with interface mode set to DTE	<p>You can specify the following clocking methods for NRZ and TDM circuits with DTE mode specified:</p> <ul style="list-style-type: none"> <li>• Custom—The custom clocking configuration is used.</li> <li>• DTE, All Clocked by Ext Clk (ST/RT)—The DCE equipment provides all clocks. The ST input clock is used to clock out the external transmit clock (TT) and the send data (SD). The RT input clock is used to clock in the receive data (RD).</li> <li>• DTE, All Clocked by User Clk(RT)—The DCE equipment provides all clocks. The RT input clock is used to clock out the external transmit clock (TT) and the send data (SD) and to clock in the receive data (RD).</li> </ul>
ISOCH	<p>You can specify the following clocking methods for ISOCH circuits:</p> <ul style="list-style-type: none"> <li>• ISOCH - Master End—This end of the circuit generates a clock signal and sends it to the remote end. Configure <b>ISOCH - Slave End</b> at the remote end.</li> <li>• ISOCH - Slave End—This end of the circuit uses adaptive clocking to receive the clock signal from the remote end. The client clock uses its period to determine when to sample data and how to transmit data across the link.</li> </ul> <p>If you specify client end, the adaptive clocking configuration appears.</p> <ul style="list-style-type: none"> <li>• Custom—The custom clocking configuration is used.</li> </ul>
CDI	<p>You can specify the following clocking methods for CDI circuits:</p> <ul style="list-style-type: none"> <li>• CDI - Master End—This end of the circuit generates a clock signal and sends it to the remote end. <b>Configure CDI - Slave End</b> at the remote end.</li> <li>• CDI - Slave End—This end of the circuit uses adaptive clocking to receive the clock signal from the remote end. The client clock uses its period to determine when to sample data and how to transmit data across the link.</li> </ul> <p>If you specify CDI-Slave End, the adaptive clocking configuration appears.</p> <ul style="list-style-type: none"> <li>• Custom—The custom clocking configuration is used.</li> </ul>

Table 60: Clocking Type Supported for Each Encoding Type as Displayed in CTPView (Continued)

Encoding Type	Clocking Type Supported
TRANS	<p>You can specify the following clocking methods for TRANS circuits:</p> <ul style="list-style-type: none"> <li>• TRANS - Master End—This end of the circuit generates a clock signal and sends it to the remote end. Configure <b>TRANS - Slave End</b> at the remote end.</li> <li>• TRANS - Slave End—This end of the circuit uses adaptive clocking to receive the clock signal from the remote end. The client clock uses its period to determine when to sample data and how to transmit data across the link.</li> </ul> <p>If you specify TRANS - Slave End, the adaptive clocking configuration appears.</p> <ul style="list-style-type: none"> <li>• Custom—The custom clocking configuration is used.</li> </ul>

## Configuring Custom Clocking for CTP Bundles (CTPView)

The custom clocking configuration allows you to configure the source for all clocks and specify which clocks are used to sample and transmit data. The configuration provides complete control over how clocks are used, and we recommend that you have a good understanding of circuit and system clocking before you use this configuration.

You can use custom clocking to:

- Configure the interface to use nonstandard clock configurations that meet the timing needs of your application.
- Configure asymmetric clocks.
- Create special configurations for devices such as tactical radios.

Before you begin:

- Log in to the CTPView software at least at the Net\_Admin level.
- Connect the CTPView server to the CTP device for which you want to configure bundles.

To configure custom clocking for CTP bundles using CTPView:

1. In the side pane, select **Bundle > Configuration**.

2. Run your mouse over the **Display and Select an Existing Bundle** bar.
3. In the table of bundles, select the bundle that you want to modify.
4. Under **Port Options** in the **Clock Cfg** field, select **Custom**.
5. Select **Custom Clocking Options Show** to display custom clocking parameters and configure the parameters as described in [Table 61 on page 200](#).

The options vary depending on the **I/F Type** selected.

6. Click **Click to Submit Bundle AND Port Changes**.

**Table 61: CTP Bundle Custom Clocking Settings in CTPView**

Field	Function	Your Action
DDS Frequency	Specifies a fixed frequency for the Direct Digital Synthesizer (DDS).	Enter a number from 1 through 2,147,483,647 Hz.
DDS Post Divider	Specifies the divider for the DDS.	Enter a number from 0 through 4.
DDS Source	Specifies the clock source for the DDS.	Select one: <ul style="list-style-type: none"> <li>• USER—The clock is recovered from the user equipment.</li> <li>• ADAP—DDS uses adaptive clocking to recover the clock signal from the remote CTP device.</li> <li>• AUTO—Use for the autobaud feature. This setting enables the monitoring of OAM packets for the terminal timing (TT) frequency at the other end and processing to accommodate frequency changes that are detected.</li> </ul>



Table 61: CTP Bundle Custom Clocking Settings in CTPView (Continued)

Field	Function	Your Action
DIV Source	<p>Specifies the source for the divider clock. The DIV clock is an alternative clock generator for the bundle, and its output clock is an even integer divider of its source clock.</p> <p>The divider is used to configure asymmetric circuits.</p> <p>For example, if the source clock is 512 KHz, the output of the DIV clock can be 256 KHz, 128 KHz, 85.333 KHz, and so on.</p>	<p>Select one:</p> <ul style="list-style-type: none"> <li>• DDS—Direct digital synthesizer clock generator.</li> <li>• OSC—Oscillator system clock.</li> </ul>
DIV Clk Divider	<p>Specifies the divider clock value. The clock value of the DIV source is divided by this value to obtain the output clock value of the DIV clock.</p>	<p>Enter an even number from 2 through 64,000.</p>
ST Net Bound I/F Clock	<p>Specifies the clock used for Send Timing on the network bound interface.</p>	<p>Select one:</p> <ul style="list-style-type: none"> <li>• OFF—No clock is used.</li> <li>• DDS—Direct digital synthesizer clock generator.</li> <li>• TT—Transmit timing clock. The interface clock signal from the DTE to the DCE (CTP device). The TT clock is used only if the bundle is configured as the DCE.</li> <li>• DIV—Divider clock generator.</li> <li>• ST—Send timing clock. The interface clock signal from the DCE to the DTE (CTP device). The ST clock is used only if the bundle is configured as the DTE.</li> </ul>

Table 61: CTP Bundle Custom Clocking Settings in CTPView *(Continued)*

Field	Function	Your Action
RF Net Bound I/F Clock	Specifies the clock used for Receive Frequency on the network bound interface.	Select one: <ul style="list-style-type: none"> <li>• OFF—No clock is used.</li> <li>• DDS—Direct digital synthesizer clock generator.</li> <li>• TT—Transmit timing clock. The interface clock signal from the DTE to the DCE (CTP device). The TT clock is used only if the bundle is configured as the DCE.</li> <li>• DIV—Divider clock generator.</li> <li>• ST—Send timing clock. The interface clock signal from the DCE to the DTE (CTP device). The ST clock is used only if the bundle is configured as the DTE.</li> </ul>
RX Net Bound SCC Clock	Specifies the clock used for the Receive Data path on the network bound serial communications controller (SCC).	Select one: <ul style="list-style-type: none"> <li>• OFF—No clock is used.</li> <li>• DDS—Direct digital synthesizer clock generator.</li> <li>• TT—Transmit timing clock. The external transmit clock used to provide clocking from the CTP device to the user equipment.</li> <li>• DIV—Divider clock generator.</li> <li>• ST—Send timing clock. The interface clock signal from the user equipment to the CTP device.</li> </ul>

Table 61: CTP Bundle Custom Clocking Settings in CTPView (Continued)

Field	Function	Your Action
RT I/F Bound I/F Clock	Specifies the clock used for Receive Timing on the interface bound interface.	<p>Select one:</p> <ul style="list-style-type: none"> <li>• OFF—No clock is used.</li> <li>• DDS—Direct digital synthesizer clock generator.</li> <li>• TT—Transmit timing clock. The external transmit clock used to provide clocking from the CTP device to the user equipment.</li> <li>• DIV—Divider clock generator.</li> <li>• ST—Send timing clock. The interface clock signal from the user equipment to the CTP device.</li> </ul>
TX I/F Bound SCC Clock	Specifies the clock used for the Transmit Data path on the interface bound serial communications controller (SCC).	<p>Select one:</p> <ul style="list-style-type: none"> <li>• OFF—No clock is used.</li> <li>• DDS—Direct digital synthesizer clock generator.</li> <li>• TT—Transmit timing clock. The external transmit clock used to provide clocking from the CTP device to the user equipment.</li> <li>• DIV—Divider clock generator.</li> <li>• ST—Send timing clock. The interface clock signal from the user equipment to the CTP device.</li> </ul>

## Configuring Adaptive Clocking for CTP Bundles (CTPView)

The adaptive clocking configuration allows you to modify attributes that affect the adaptive clocking algorithm. The default settings are acceptable for most applications. We recommend that you change these settings only with the assistance of JTAC.

Before you begin:

- Log in to the CTPView software at least at the Net\_Admin level.

- Connect the CTPView server to the CTP device for which you want to configure bundles.

To configure adaptive clocking for CTP bundles using CTPView:

1. In the side pane, select **Bundle > Configuration**.
2. Run your mouse over the **Display and Select an Existing Bundle** bar.
3. In the table of bundles, select the bundle that you want to modify.
4. Under **Port Options** in the **Clock Cfg** field, select **Adap Rate - Ext Clk** or **Adap Rate - Int Clk**.
5. Select **Adaptive Clocking Options Show** to display adaptive clocking parameters and configure the parameters as described in [Table 62 on page 204](#).
6. Click **Click to Submit Bundle AND Port Changes**.

**Table 62: CTP Bundle Adaptive Clocking Settings in CTPView**

Field	Function	Your Action
Initialize Adaptive Settings	Sets the adaptive clocking configuration to the default settings.	Select <b>Yes</b> .
Aggressive Calc Period	Specifies the time period during initial start of adaptive clocking during which packet samples that are experiencing the least delay through the network are collected. These samples are used for aggressive state calculations.	Enter a number from 3 through 200 seconds.
Maintenance Calc Period	Specifies the time period during normal adaptive clocking during which packet samples that are experiencing the least delay through the network are collected. These samples are used for maintenance state calculations.	Enter a number from 3 through 300 seconds.

Table 62: CTP Bundle Adaptive Clocking Settings in CTPView *(Continued)*

Field	Function	Your Action
Slope for Maintenance	Specifies the number of packets per minute, which, when reached, causes the adaptive clocking algorithm to change from aggressive state to maintenance state. Lower values result in longer switchover times with a clock value closer to the remote clock.	Enter a number from 1 through 100 packets per minute.
Maintenance Decay	Specifies how quickly the clocking corrects to the buffer set point while in maintenance state.	Enter a number from 2 through 120 seconds.
Max Clock Adjustment Value	Specifies a cap for frequency acceleration, which constrains the frequency adjustments to the adaptive clock.	Enter a number from 1 through 200 parts per billion.
Max Clock Offset	Specifies a cap for frequency velocity, which constrains the frequency velocity of the adaptive clock.	Enter a number from 1 through 400 packets per minute.
Max Buffer Error	Specifies the buffer error rate required to change the adaptive clocking algorithm state from maintenance to aggressive.	Enter a number from 100 through 1,000,000 microseconds.

## RELATED DOCUMENTATION

[Adaptive Clocking Overview for CTP Bundles](#) | 7

## Configuring PBS and Bridge Ports (CTPView)

Configuring a packet-bearing serial (PBS) interface allows you to connect a CTP device to an IP network through a serial interface. A port configured as a PBS interface uses static routes and does not participate in any routed protocol sessions, such as OSPF and RIP.

A port must be configured as either a circuit emulation port or a PBS interface or as a bridge port. The default is the circuit emulation port. You can configure a PBS interface or bridged ports from the CTPView web interface or from the CTP menu. This section describes how to configure PBS from CTPView.

If any port on a CTP node is configured as a PBS or bridge port, then the Direct Drive option is automatically set to Disabled on all bundles on that node. If a port is configured as a PBS or bridge port, then all the bundles on that port is deleted. If a bundle is created on a different port, the Direct Drive option is disabled on that port when other ports are configured as a PBS or bridge port.

To configure PBS or bridge port from CTPView:

1. In the side pane, select **Node > PBS/Bridge Config**.  
The PBS/Bridge Port Configuration pane is displayed.
2. Click **Add or Delete PBS/Bridged Ports**.  
The PBS/Bridge Port Mode Selection page is displayed.
3. From the PBS/Bridge Mode Ports page, select the port that you want to configure as a PBS or bridge port, and click **Submit Mode Selections**.
4. Run your mouse over the **MouseOver to Display and Select an Existing PBS & Bridge Port** bar.
5. From the table of ports, select the port that you want to configure as a PBS port.
6. Specify the options as described in [Table 63 on page 206](#), and click **Click to Submit Port Changes**.

**Table 63: Configuration Options for a PBS Port**

Field	Function	Your Action
Port description	Specifies a description for the port.	Enter a description of up to 64 alphanumeric characters. Use only the following special characters:  _ + @ : , . -

Table 63: Configuration Options for a PBS Port *(Continued)*

Field	Function	Your Action
Encapsulation	PBS interfaces support PPP and HDLC encapsulation.	Select one: <ul style="list-style-type: none"> <li>• CHDLC</li> <li>• PPP</li> </ul>
Local Address of P2P Link	The PBS interface requires that the IP address of the local IP interfaces be specified.	Enter the IP address of the local IP interface.
Remote ip of p2p link	The PBS interface requires that the IP address of the remote IP interfaces be specified.  Both the local and the remote IP interfaces must be on the same network.	Enter the IP address of the remote IP interface.

Table 63: Configuration Options for a PBS Port *(Continued)*

Field	Function	Your Action
Clock Config	<p>The clock configuration submenu lets you configure port speed and clock configuration. The clocking options include configured rate with and without external TT, all clocked by external TT, and custom clocking.</p> <p>CTPView allows you to configure the rate using an input field and to specify the clocking from a drop-down menu of valid options.</p>	<p>Select one:</p> <ul style="list-style-type: none"> <li>• Cfg Rate - Int Clk—Configured rate without external TX clock (TT). The CTP device synthesizes the rate that is used on the ST and RT outputs to the attached device. The ST is used to sample Send Data from the attached DTE. The clock is created by the CTP DDS circuitry and logic. This option is commonly used on circuits that are less than 1 Mbps.</li> <li>• Cfg Rate - Ext Clk—Configured rate with external TX clock (TT). The CTP device synthesizes the rate that is used on the ST and RT outputs to the attached device. The clock is created by the DDS circuitry and logic. This option is used to sample Send Data from the attached device. It assumes that the attached device is using an ST or a clock reference that is traceable to CTP reference. It is typically used for higher data rates (&gt;1 Mbps) and long cables.</li> <li>• All Clock - Ext Clk—All clocked with external TX clock (TT). The CTP clock uses the external TT timing from the DTE for all clocking. Ext TT is used to sample Send Data from the attached device, to generate the RT clock, and to clock data into the IP network.</li> <li>• Custom—The custom clocking configuration is used.</li> </ul>



Table 63: Configuration Options for a PBS Port *(Continued)*

Field	Function	Your Action
Interface	The Interface is configurable to be either EIA530, EIA530A, RS232, V.35, or T1/E1 (optional when hardware is installed). The encoding is limited to NRZ.	Select one: <ul style="list-style-type: none"> <li>• EIA530</li> <li>• EIA530A</li> <li>• RS232</li> <li>• V.35</li> <li>• T1/E1</li> </ul>
MTU	The MTU can be configured to a value up to 1500 bytes. MTU fragmentation is not supported.	Enter the MTU in bytes. The default value is 1500.
First static route	You can configure up to three active static routes that use the PBS interface. The static routes must not conflict with the static routes configured on any other PBS Interfaces.	Enter up to three static routes.
Second static route		
Third static route		

## RELATED DOCUMENTATION

[Configuring PBS and Bridge Ports \(CTP Menu\) | 115](#)

[Monitoring PBS and Bridge Ports Configuration from CTPView](#)

## Configuring Port Mirroring for CTP Bundles (CTPView)

Port mirroring enables carrying the data on a unidirectional bundle (or one direction of a bidirectional bundle), replicating it, and sending it to an additional port (that is, a port mirroring tail). The data replication may happen at the source (CTP on which the data enters the IP network) or destination (CTP

on which the data exits the IP network). Tails are actually unidirectional source bundles associated with the CTP bundle, which need to be terminated on a unidirectional destination bundle.

You can configure a maximum of 25 tails for each port mirroring type (source and destination), and the entire CTP bundle can have a maximum of 50 tails (25 source tails and 25 destination tails). See [Figure 15 on page 210](#) for the allowed port mirroring configurations.

Bundles that use port mirroring must have the direct drive disabled. When a bundle configuration that has a port mirroring component is submitted, the CTPView software enforces the direct drive rule when the node is configured to the new settings.

**Figure 15: Allowed Port Mirroring Configurations**

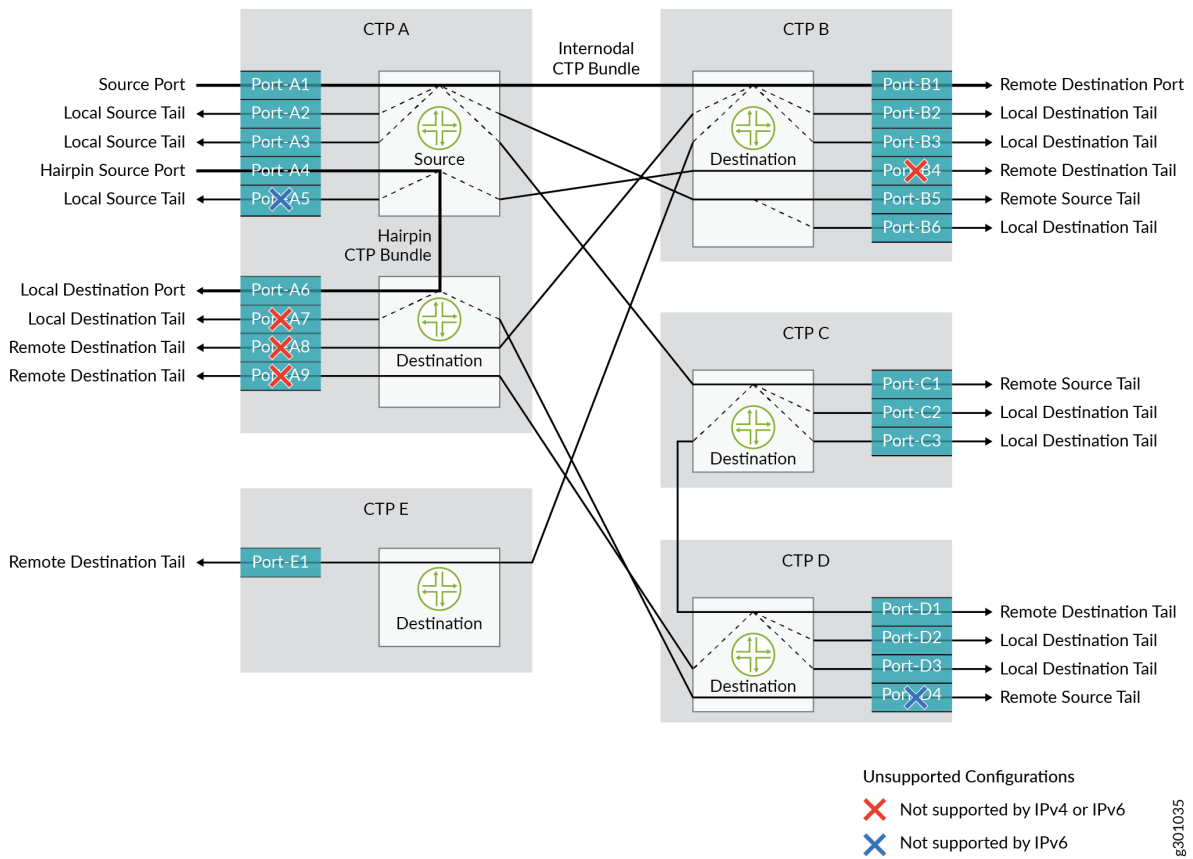
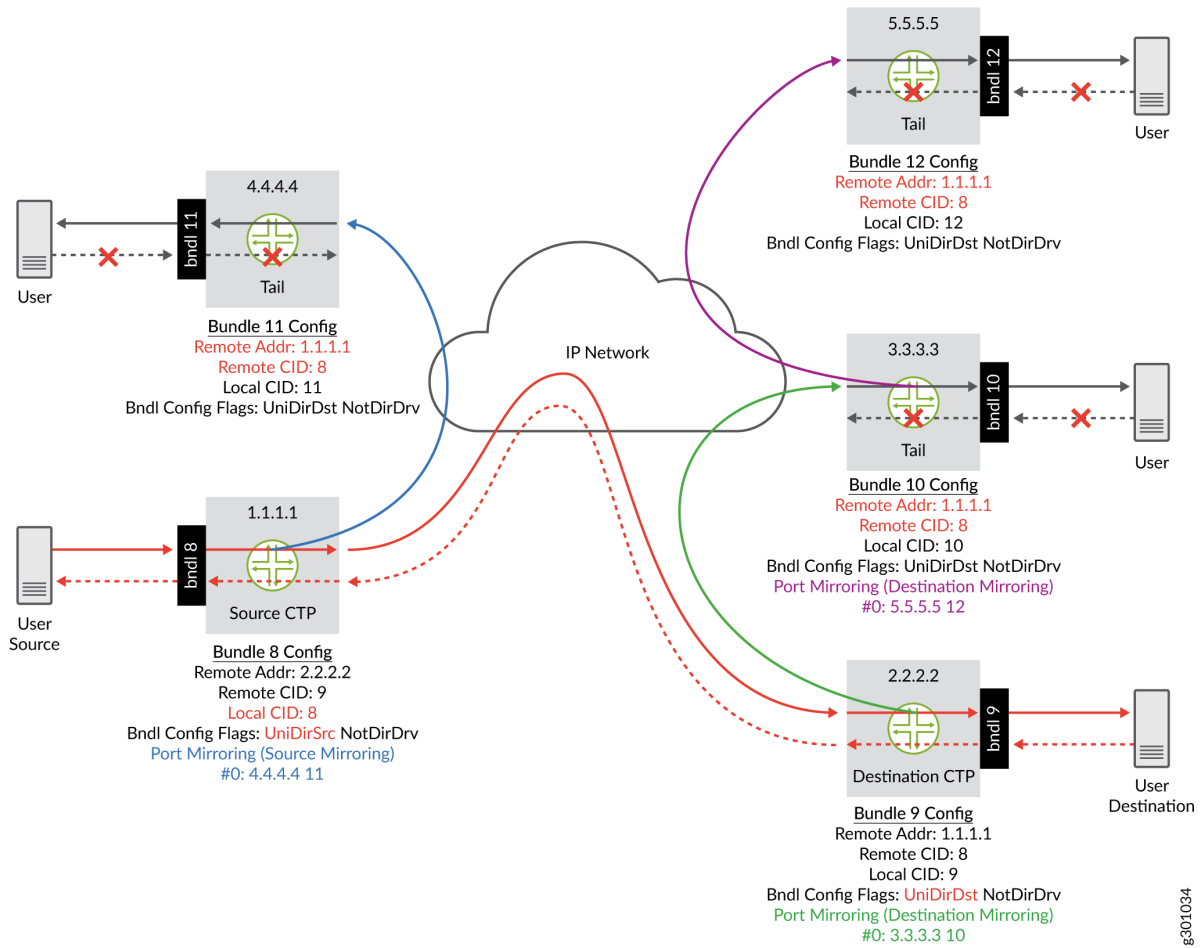

**Table 64: Port Names and Descriptions**

Port Name	Description
CTP Bundle	The CTP bundle from which mirrored ports are created.
Source Port	The source of user data, and the source port for the CTP bundle. The source port can be either unidirectional or full-duplex.
Remote Destination Port	Destination port (remote from the source port) for the CTP bundle, carrying user data.
Local Destination Port	Destination port (local to source port, that is, hairpin) for the CTP bundle, carrying user data.
Local Source Tail	Mirrored port from the source side of CTP bundle, terminating on the same node as source tail point.
Remote Source Tail	Mirrored port from source side of CTP bundle, terminating on a different node from the source tail point.
Local Destination Tail	Mirrored port from destination side of any (CTP or remote source/destination tail) bundle, terminating on the same node as the tail point.
Remote Destination Tail	Mirrored port from destination side of any (CTP or remote source/destination tail) bundle, terminating on a different node as the tail point.  <b>NOTE:</b> A remote destination tail port that terminates on the CTP bundle source side is not allowed.

Destination tails need to be configured to point back to the source port of the CTP bundle. See [Figure 16 on page 212](#) for an example port mirroring configuration.

Figure 16: Example Port Mirroring Configuration



**NOTE:** To view and configure port mirroring parameters, you must login as an administrator.

**NOTE:** You cannot configure the destination port mirroring tail with a remote IP address that is the same as the IP address of the Source CTP.

**NOTE:** For serial ports, the default port speed of a bundle is set to 1024 KHz. If you are configuring more than 11 source or destination tails on a single node, the bundle goes to TooFast state, as it exceeds the maximum allowed port speed (12880 KHz), calculated as (port speed \* 10).

6301034

(number of configured source and destination tails + 1)). With 25 tails configured for each type of port mirroring, the bundle is in Running state only when the port speed is set to 256 KHz or less. As port speed is set to a constant value for T1/E1 ports, you cannot configure more than 7 tails for T1 ports or more than 5 tails for E1 ports. If you try to do so, the bundle goes to TooFast state.

You can configure source and destination port mirroring for a CTP device from CTPView.

To configure source and destination port mirroring for CTP bundles from CTPView:

1. In the side pane, select **Bundle > Configuration**.
2. Run your mouse over the **Display and Select an Existing Bundle** bar.
3. In the table of bundles, select the bundle that you want to configure.
4. Under **Bundle Options**, select **Advanced Options Show** and configure the parameters as described in [Table 65 on page 213](#).

**Table 65: Unidirectional and Bidirectional Circuit Options**

Field	Description
Unidirectional Circuit	<p>Select one:</p> <ul style="list-style-type: none"> <li>• Bi-directional—Select to configure both source ad destination port mirroring.</li> <li>• Source—Select to configure only source port mirroring that enables mirroring network bound data.</li> </ul> <p><b>NOTE:</b> Source port mirroring is not supported for hairpin bundles (when source and remote destinations are on the same node) with IPv6 addressing.</p> <ul style="list-style-type: none"> <li>• Destination—Select to configure only destination port mirroring that enables mirroring interface bound data.</li> </ul> <p><b>NOTE:</b> Destination port mirroring is not supported for hairpin bundles with IPv4 or IPv6 addressing.</p>

5. Under **Bundle Options**, select **Source Port Mirroring Show** and the **Destination Port Mirroring Show** and configure the parameters as described in [Table 66 on page 214](#).

Table 66: CTP Bundle Source Port Mirroring Settings in CTPView

Field	Your Action
Remote IP [ IPv4 only ]	Enter the remote IP address.
Remote Address [ IPv4 only ]	Click to select the remote IP address from the list.  Select the <b>Remove Tail</b> check box to remove the port mirroring tail from the bundle. The check box will be visible only if port mirroring is configured.
Remote CID [ 0 -249 ]	Enter the remote circuit ID in the range 0-249.

6. Click **Click to Submit Bundle AND Port Changes**.

## RELATED DOCUMENTATION

| [Configuring Port Mirroring for CTP Bundles \(CTP Menu\)](#) | 119

## Configuring NetRef Settings (CTPView)

NetRef primary backup operation involves a new packet flow from the primary node to all the backup nodes. These timing packets are sent at a rate of approximately 4.5 packets per second.

**NOTE:** In this topic, the terms *Primary* and *Backup* refer to primary and client operations or nodes, respectively.

To configure network node reference with primary and backup operation using the Node Configuration page of CTPView:

1. In the side pane, select **Node > Node Config**.
2. Configure the parameters described in [Table 67 on page 215](#) and click **Submit Configuration**.
3. (Optional) Click **Node > Node Query** to verify the NetRef primary and backup node configuration details.

Table 67: Node Configuration Settings Page in CTPView

Field	Function	Your Action
Port Providing Reference	<p>Specifies whether you want to enable or disable the NetRef primary node to function as the reference port providing frequency for clock synchronization.</p> <p>You need to specify this value for the <b>1st Priority Reference 0, 2nd Priority Reference 1, 3rd Priority Reference 2, 4th Priority Reference 3, and 5th Priority Reference 4</b> fields to specify the reference clocks for the primary nodes with corresponding priorities.</p>	Select <b>Yes</b> or <b>No</b> to enable or disable the primary node to function as the reference clock.
Reference Frequency	<p>Specifies the frequency to be used for the reference clock or the primary node.</p> <p>You need to specify this value for the <b>1st Priority Reference 0, 2nd Priority Reference 1, 3rd Priority Reference 2, 4th Priority Reference 3, and 5th Priority Reference 4</b> fields to specify the reference clocks for the primary nodes with corresponding priorities.</p>	<p>Select a reference frequency in the range from 32 KHz through 4096 KHz.</p> <p>You can configure the CTP systems by using the menu interface to provide multiple prioritized node clock references. An external reference input and any of the serial interfaces may be used for the node reference clock. Reference frequencies must be 32 KHz, n x 64 KHz, or 1,544 KHz up to a maximum of 4096 KHz (2048 KHz maximum on the CTP1002).</p>
NetRef: Slave	Specifies the client node for which multiple primary nodes are associated for receiving clock synchronization information.	Select the client node to be locked to the different primary nodes.
Master IP (Priority # 1)	Specifies the IP address of the primary node with priority 1.	Enter the IP address of the primary node with priority 1.
Master IP (Priority # 2)	Specifies the IP address of the primary node with priority 2.	Enter the IP address of the primary node with priority 2.
Master IP (Priority # 3)	Specifies the IP address of the primary node with priority 3.	Enter the IP address of the primary node with priority 3.

Table 67: Node Configuration Settings Page in CTPView *(Continued)*

Field	Function	Your Action
Master IP (Priority # 4)	Specifies the IP address of the primary node with priority 4.	Enter the IP address of the primary node with priority 4.
32 kHz Reference Output	Specifies whether you want to enable the reference output signal.	Select the <b>Enable</b> check box if it is already disabled.
Clock Main RTM	Specifies the clock rear transition module (RTM) used to input a reference clock into the CTP2000 platform.	Select a value from the Port DB25 drop-down list to use clock module RTM.



# 3

PART

## Administration

---

[Activating, Disabling, Deleting, or Recentering CTP Bundles | 218](#)

[Querying CTP Bundles | 220](#)

[Monitoring Packet Creation and Reception and Packet Delay | 247](#)

[Diagnostic Testing for CTP Bundles Overview | 251](#)

[Configuring and Displaying Diagnostic Testing for CTP Bundles | 256](#)

[Reducing the Number of SNMP Traps Generated for Late and Missing Packets | 266](#)

---

# Activating, Disabling, Deleting, or Recentering CTP Bundles

## IN THIS CHAPTER

- [Activating, Disabling, Deleting, or Recentering CTP Bundles \(CTPView\) | 218](#)
- [Activating, Disabling, Deleting, or Recentering for CTP Bundles \(CTP Menu\) | 218](#)

## Activating, Disabling, Deleting, or Recentering CTP Bundles (CTPView)

This topic describes how to change the status of bundles. You can recenter only active CTP and SAToP bundles.

Before you begin:

- Log in to the CTPView software at least at the Net\_Admin level.
- Connect the CTPView server to the CTP device for which you want to change the status of the bundles.

To change the status of bundles:

1. In the side pane, select **Bundle > Change Status**.
2. Select the appropriate boxes and click **Submit**.

## Activating, Disabling, Deleting, or Recentering for CTP Bundles (CTP Menu)

You can recenter only active CTP bundles.

To activate, disable, delete, or recenter bundles using the CTP Menu:

1. From the CTP Main Menu, select **1) Bundle Operations**.

2. Select the type of bundle.
3. Select a bundle from the list.
4. From the menu, select the option that you want to perform on the bundle:
  - 4) Activate
  - 5) Disable
  - 6) Recenter

# Querying CTP Bundles

## IN THIS CHAPTER

- [Displaying the Running CTP Bundle Configuration, State, and Counters \(CTP Menu\) | 220](#)
- [Displaying the NetRef Node Synchronization Information \(CTP Menu\) | 232](#)
- [Displaying Running CTP Bundle Configuration, State, and Counters \(CTPView\) | 234](#)

## Displaying the Running CTP Bundle Configuration, State, and Counters (CTP Menu)

To display a bundle using the CTP Menu:

1. From the CTP Main Menu, select **1) Bundle Operations**.
2. Select the type of bundle.
3. Select a bundle from the list.
4. From the menu, select **1) Query**. The configuration of the bundle appears followed by the runtime state and counters.

[Table 68 on page 221](#) describes the fields in the state and counters sections of the display.

The signaling configuration appears only if you changed the signaling configuration from the default configuration.

Table 68: CTP Bundle Runtime State and Counters in the CTP Menu

Field Name	Field Description
Run State	<p data-bbox="456 365 878 394">Displays the current state of the bundle:</p> <ul style="list-style-type: none"> <li data-bbox="456 428 808 457">• <b>DISABLD</b>—Bundle is disabled.</li> <li data-bbox="456 491 1409 520">• <b>No Sync</b>—The local CTP device is not able to communicate with the remote CTP device.</li> <li data-bbox="456 554 1409 625">• <b>In Sync</b>—The local CTP device is communicating properly with the remote device (OAM packets), but data is not flowing.</li> </ul> <p data-bbox="493 659 1398 751">The bundle will remain In Sync when network bandwidth is insufficient to transmit the data packets. If the bundle is configured as demand on RTS high, and RTS is currently low, then also the bundle remains in the InSync state until RTS rises.</p> <ul style="list-style-type: none"> <li data-bbox="456 785 1393 856">• <b>Running</b>—The local CTP device is communicating and is synchronized with the remote CTP device. The circuit is established between the bundles.</li> <li data-bbox="456 890 1398 995">• <b>Eval</b>—The bundle is in the transition state between No Sync and In Sync. The bundle is configured to use an external (TT) clock, and this clock is being measured to see if it is the proper frequency.</li> <li data-bbox="456 1029 1393 1134">• <b>TooSlow</b>—The CTP bundle configuration is not possible because it consumes too little resources. For example, the configured port parameters yield a data rate, which is less than or equal to 0.</li> <li data-bbox="456 1167 1414 1272">• <b>TooFast</b>—The CTP bundle configuration is not possible because it consumes too much resources. For example, the configured port speed and packet size gives a bundle packet rate that exceeds the maximum of 1000 packets per second.</li> <li data-bbox="456 1306 1317 1377">• <b>TtFAIL</b>—The CTP bundle reaches the TtFAIL state from the Eval state when the measured TT is more than 6.25% of the configured (expected) TT frequency</li> <li data-bbox="456 1411 1349 1516">• <b>MisCfg</b>—A misconfiguration of the bundles between the local and remote devices prevents the circuit from being brought up. For example, incorrectly configured IP addresses and mismatched speeds.</li> <li data-bbox="456 1549 1370 1621">• <b>CfgFail</b>—The configuration of the bundle cannot be supported. If you encounter this error, delete the bundle and create a new bundle.</li> <li data-bbox="456 1654 1419 1759">• <b>AutoWait</b>—The bundle is configured for AutoBaud clocking and the user clock (TT) has recently changed. The state machine is waiting for the TT to stabilize before bringing the circuit up.</li> </ul>

Table 68: CTP Bundle Runtime State and Counters in the CTP Menu *(Continued)*

Field Name	Field Description
Port Runtime Flags	<p data-bbox="456 363 1084 390">Displays the current configuration of BERTs and serial loops.</p> <ul style="list-style-type: none"> <li data-bbox="456 426 1421 594">• Sdlnactive—No activity is detected on the serial input. The activity detector checks the serial input line every 500 milliseconds for any transitions on the line. Port Run Time flag of the serial CTP bundle shows the status as Inactive if no activity is detected on the serial input line. This flag is displayed only when the serial input line is inactive, which is an abnormal condition. No such flag is displayed if the serial input line is active.</li> </ul> <p data-bbox="493 627 1386 688">This flag applies only to a serial port that has a T1E1 DCARD installed and is in use. It does not apply to ports on a T1E1 card.</p> <ul style="list-style-type: none"> <li data-bbox="456 728 1406 825">• BertFrmNet—Receive BERT for this port is active and is monitoring the interface bound data. Receive BERT is only a monitoring function and does not affect the interface bound data.</li> <li data-bbox="456 865 1421 961">• BertFromIf—Receive BERT for this port is active and is monitoring the network bound data. Receive BERT is only a monitoring function and does not affect the network bound data.</li> <li data-bbox="456 1001 1414 1062">• BertToNet—Transmit BERT for this port is active and is sending the network bound data, thereby interrupting the normal data path from the interface.</li> <li data-bbox="456 1102 1393 1163">• BertToIf—Transmit BERT for this port is active and is sending the interface bound data, thereby interrupting the normal data path from the IP network.</li> <li data-bbox="456 1203 1349 1264">• LoopToNet—Interface bound data is looped back towards the IP network, thereby interrupting the normal network bound data. Interface bound data is not interrupted.</li> <li data-bbox="456 1304 1305 1365">• LoopToIf—Network bound data is looped back towards the interface, thereby interrupting the interface bound data. Network bound data is not interrupted.</li> </ul>

**Table 68: CTP Bundle Runtime State and Counters in the CTP Menu (Continued)**

Field Name	Field Description
IRIG-B Run Flags	<p>Displays the current status of the IRIG-B runtime</p> <ul style="list-style-type: none"> <li>• TxIpSync—Transmit mode is in sync with the remote CTP device. The local IRIG module is able to recover the framed IRIG signal from the data arriving from the remote IRIG module through the IP network.</li> <li>• TxSyncLost—Transmit mode is not in sync with the remote CTP device. This flag is set whenever the TxIpSync flag is active after issuing the last port counter clear command. When activated, it remains active until you issue the next port counter clear command.</li> <li>• RxIrigSync—Receive mode is in sync with the remote CTP device. The local IRIG module is able to recover the IRIG signal from the data arriving from the IRIG signal arriving at the interface.</li> <li>• RxSyncLost—Receive mode is not in sync with the remote CTP device. This flag is set when the RxIrigSync flag is active after issuing the last port counter clear command. When activated, it remains active until you issue the next port counter clear command.</li> </ul>
<b>Bundle Config</b>	
DBase State	Displays whether the bundle is active or disabled.
Remote Addr	Displays the remote IP address.
Remote CID	Displays the remote circuit ID in the range 0-249.
Local CID	Displays the local circuit ID in the range 0-249.
Packet size	Displays the size of IP packets that are created on the interface (T1/E1 or Serial).
Buf Max/Set/Min(ms)	Displays the maximum, running state, and minimum buffer sizes, in terms of milliseconds. The number that you entered varies depending on the interface type and port speed. The set buffer size denotes the buffer size when the circuit enters a running state.

**Table 68: CTP Bundle Runtime State and Counters in the CTP Menu (Continued)**

Field Name	Field Description
IP Hdr TOS	Displays the ToS byte to be used in IP headers of packets sent from the CTP device to the IP network. The ToS setting is applied to circuits created by the bundle for which the service type is configured.
IP Proto/OAM Port	Displays the port configured for IP protocol and OAM applications.
Port(s) in bundle	Displays the interfaces that are part of the configured bundle.
Bndl Desc	Displays the description of the bundle, which enables easy identification.



Table 68: CTP Bundle Runtime State and Counters in the CTP Menu *(Continued)*

Field Name	Field Description
Bndl Config Flags	<p data-bbox="456 363 964 390">Displays the current configuration of the bundle:</p> <ul data-bbox="456 426 1421 1623" style="list-style-type: none"> <li data-bbox="456 426 1421 562">• PProtTx—Indicates that the packet protector is set to “Send cloned packets to NET”. The CTP device uses cloned packets that it receives when the IP network drops the original packet. If the device receives both the original and cloned packets, it ignores the cloned packet.</li> <li data-bbox="456 598 1421 735">• PProtRx—Indicates that the packet protector is set to “Expect cloned packets from NET”. The CTP device uses cloned packets that it receives when the IP network drops the original packet. If the device receives both the original and cloned packets, it ignores the cloned packet.</li> <li data-bbox="456 770 1421 869">• PProtTx PProtRx—Indicates that the packet protector is set to “Send &amp; expect cloned packets”. The CTP device sends duplicated packets over the IP network. The CTP device uses cloned packets that it receives when the IP network drops the original packet.</li> <li data-bbox="456 905 1421 1003">• PProtTxDel—Indicates that the packet protector is set to “Send delayed cloned packets to NET”. The CTP device sends duplicated packets after the interpacket delay of the circuit.</li> <li data-bbox="456 1039 1421 1176">• PProtTxDel PProtRx—Indicates that the packet protector is set to “Send delayed &amp; expect cloned packets”. The CTP device sends duplicated packets after the interpacket delay of the circuit. The CTP device uses cloned packets that it receives when the IP network drops the original packet.</li> <li data-bbox="456 1211 1421 1348">• PProtRxXor—Indicates that the packet protector is set to “Expect cloned XOR packets”. The CTP device uses cloned XOR packets that it receives when the IP network drops the original packet to regenerate the missing packet. If the device receives both the original and cloned XOR packets, it ignores the cloned packet.</li> <li data-bbox="456 1383 1421 1520">• PProtTxXor PProtRxXor—Indicates that the packet protector is set to “Send &amp; expect cloned XOR packets”. The CTP device sends duplicated XOR packets over the IP network. The CTP device uses cloned XOR packets that it receives to regenerate missing packets when the IP network drops the original packet.</li> <li data-bbox="456 1556 1421 1623">• PProtTxXor—Indicates that the packet protector is set to “Send cloned XOR packets”. The CTP device sends duplicated XOR packets over the IP network.</li> </ul>
<b>Port Config</b>	
Port Desc	Displays the description of the port.

Table 68: CTP Bundle Runtime State and Counters in the CTP Menu *(Continued)*

Field Name	Field Description
Interface type	<p>Displays the type of interface.</p> <p>The type of interface that you select affects the default packet size and buffer sizes for the bundle.</p>
Port Config Flags	<p>Displays the current configuration of the port:</p> <ul style="list-style-type: none"> <li>• T1LoSCheck—Denotes that LOS detection is specified on a T1 port connected to a CTP bundle or a SAToP bundle</li> <li>• E1LoSCheck—Denotes that LOS detection is specified on a E1 port connected to a CTP bundle or a SAToP bundle</li> <li>• NoRdReclk flag—Signifies that the redundancy receiving (RX) clock is disabled. The NoRdReclk flag is also displayed because this flag is default enabled for a T1/E1 port, whereas it is usually not enabled for a serial port.</li> </ul> <p>When you run the bundle query for CTP bundles and SAToP bundles, the T1E1 port type displays port configuration flags that are relevant to a T1E1 port.</p>
Framing type	<p>Displays the framing type for T1 interfaces.</p> <ul style="list-style-type: none"> <li>• ESF</li> <li>• D4</li> </ul>

Table 68: CTP Bundle Runtime State and Counters in the CTP Menu *(Continued)*

Field Name	Field Description
Redundancy Config	<p data-bbox="456 365 902 390">Displays the configured redundancy mode.</p> <ul data-bbox="456 426 1409 1037" style="list-style-type: none"> <li data-bbox="456 426 1081 451">• Disable—Y-cable redundancy is not enabled on this port.</li> <li data-bbox="456 495 1409 590">• eXclusive OR (XOR)—Redundancy is enabled. In this mode the Y cable is active only if the port is in RUNNING state and the serial port on the Y-cable link is not in RUNNING state. If both bundles are RUNNING, the Y cable remains inactive on both the ports.</li> <li data-bbox="456 634 1409 800">• ReVeRT (RVRT)—When you select this mode, a primary and a secondary path is enabled. The primary path drives the cable when its bundle is in RUNNING state, independent of the state of the secondary path. The secondary path is activated when the primary path is offline. Whenever the primary path comes back online, the path is switched back to the primary path.</li> <li data-bbox="456 844 1409 938">• NOnReVert (NORV)—When you select this mode, the circuit is not switched back to primary when the primary path comes back online after switching to secondary path. The circuit is switched to the primary path only when the secondary path fails.</li> <li data-bbox="456 982 1409 1037">• Signal (SIG)—The primary path is activated only if the secondary CTS output is inactive. When CTS is active, secondary drives cable.</li> </ul>
Primary/Secondary	<p data-bbox="456 1110 1377 1205">Specifies whether it is a primary and a backup bundle. When the software link is enabled and link partners are specified, the software verifies that there is a matched primary and backup pair.</p>

Table 68: CTP Bundle Runtime State and Counters in the CTP Menu *(Continued)*

Field Name	Field Description
Pri/Sec Link Type	<p>Specifies the link types for primary and back up bundle.</p> <ul style="list-style-type: none"> <li>• H/W link—When enabled, the Y-cable redundancy is supported only on serial ports, and the link between ports is a hardware signaling connection over a special Y cable that uses the output to cable(TM) and the input from cable(RL) to communicate redundancy state between port pairs, by using keepalive pulses. Its operation is similar to the default operation of the redundancy feature in CTPOS Release 6.5 and earlier.</li> <li>• S/W link—Allows Y-cable port pairs to maintain contact with each other by means of OAM packets instead of using a hardware signaling path. The software link has the following advantages: <ul style="list-style-type: none"> <li>• The software link does not require a special signaling hardware, which means that Y-cable redundancy is supported on T1E1 ports as well as serial ports with a special Y cable. Serial ports can get TM/RL signals for user applications.</li> <li>• Software or OAM link packets can check link partners and identify configuration errors. They can also differentiate between dead and alive states.</li> </ul> </li> </ul>
IP Address	Specifies an IP address for the other port of the redundant primary and backup pair.
Line Buildout	<p>Displays the line buildout for T1 interfaces.</p> <ul style="list-style-type: none"> <li>• 0) ~133 ft</li> <li>• 1) ~266 ft</li> <li>• 2) ~399 ft</li> <li>• 3) ~533 ft</li> <li>• 4) ~655 ft</li> <li>• 5) -7.5dB CSU</li> <li>• 6) -15dB CSU</li> <li>• 7) -22.5dB CSU</li> </ul>

Table 68: CTP Bundle Runtime State and Counters in the CTP Menu *(Continued)*

Field Name	Field Description
Clock Source	<p>Displays the type of clocking for the port.</p> <ul style="list-style-type: none"> <li>• CTP is Clock Source—The PBX either returns the clock received from the CTP or it returns a clock that is traceable to the same source as the CTP node clock reference. You typically use this configuration when you configure the CTP device with a clock reference input.</li> <li>• CTP is Loop Timed—The PBX provides the clock and the CTP returns the same clock to the PBX. You typically use this configuration when the PBX has the more accurate clock source. You can configure the far end of the circuit with adaptive clocking to recover this clock if necessary.</li> <li>• CTP is Clock Source (Adaptive End)—The PBX returns the clock received from the CTP, and the CTP uses the adaptive recovered clock. You typically use this configuration when the CTP does not have a reference input and the PBX typically requires clock from the distant PBX.</li> </ul> <p>On CTP150 devices, If you set clocking to <b>CTP is Clock Source (Adaptive End)</b>, the first bundle activated on the interface is assigned as the adaptive primary bundle on which the transmit clock is adjusted. This bundle is also the last bundle to be deactivated on the interface.</p>
Port Speed (kHz)	Displays the port speed in kHz.
T1E1 flags	<p>Appears for bundles on T1/E1 interfaces.</p> <ul style="list-style-type: none"> <li>• LOS—Loss of signal. This could mean that the cable is not attached. When LOS is detected, the CTP device puts the bundle into a loop so that the TX and RX clock are looped to each other.</li> <li>• LOF—Loss of frame.</li> <li>• AIS—Alarm indication signal.</li> <li>• RAI—Remote alarm indication (yellow alarm).</li> <li>• LOF_NB—Fractional T1 only. FPGA framer loss of frame network bound.</li> <li>• LOF_IB - Fractional T1 only. FPGA framer loss of frame interface bound.</li> </ul>

Table 68: CTP Bundle Runtime State and Counters in the CTP Menu *(Continued)*

Field Name	Field Description
TT (Ext Clock)	<p>Displays the current speed of the transmit timing (TT) clock.</p> <p>The TT measurement is displayed only for a CTP bundle or a SAToP bundle that is attached to a T1E1 port on a T1E1 Daughter Card or a CTP bundle attached to a serial port with clock configuration set to <b>Configured with TT, All Clocked by TT, Adaptive Rate, w/ User Clk (TT)</b>, or <b>Autobaud Rate, w/ User Clk (TT)</b>.</p>
RT (Ext Clock)	<p>Displays the current speed of the receive timing (RT) clock.</p> <p>Appears if the bundle is configured as the DTE, and clocking is set to <b>DTE, All Clocked by Ext Clk (ST/RT)</b>.</p>
Adaptive State	<p>For bundles that are configured as the adaptive end for adaptive clocking, displays the current state of the adaptive clock:</p> <ul style="list-style-type: none"> <li>• Aggressive—Bundle is running, and adaptive clocking is in training mode.</li> <li>• Maintain (20 us)—Bundle is running, and adaptive clocking is in steady state. The value specified parentheses is the current offset from the optimal buffer level. When adaptive clocking is functioning properly, it should hover around 0.</li> <li>• N/A (Port Not RUNNING)—Bundle is disabled.</li> </ul>
Adap Recovered Freq	<p>For bundles that are configured as the adaptive end for adaptive clocking, displays the frequency currently being recovered from the primary end.</p>
Input Signals	<p>Displays the running configuration of input signals.</p>
Output Signals	<p>Displays the running configuration of output signals.</p>
Checked out PPS	<p>Displays packets per second (PPS) for the current bundle, for all running bundles on the CTP device, and the maximum PPS for the CTP device.</p> <p><b>NOTE:</b> For CESoPSN bundle, this field is available only in CTPOS release 7.0 and later.</p>

#### Counters

**Table 68: CTP Bundle Runtime State and Counters in the CTP Menu (Continued)**

Field Name	Field Description
I/F bound packets	Packets received from the IP network destined for the bundle.
NET bound packets	Packets created by the bundle and sent to the IP network.
Late pkts	Packets that were delivered to the CTP device, but arrived too late to be processed. Significant numbers of late packets indicate that the size of the buffer needs to be increased.
Missing pkts	<p>Packets that were not delivered to the CTP in time to process out the serial interface because they were either late or dropped by the IP network.</p> <p>Each time a packet is missed, the data fill pattern specified in the advanced port options is substituted for data in the missed packet. The substitution maintains the bit count integrity of the data sent to the DTE or encryptor, but results in what appears to be a burst of errors with a duration equal to the size of the packet.</p>
Late pkts	Packets that were delivered to the CTP device, but arrived too late to be processed. Significant numbers of late packets indicate that the size of the buffer needs to be increased.
Missing pkts	<p>Packets that were not delivered to the CTP in time to process out the serial interface because they were either late or dropped by the IP network.</p> <p>Each time a packet is missed, the data fill pattern specified in the advanced port options is substituted for data in the missed packet. The substitution maintains the bit count integrity of the data sent to the DTE or encryptor, but results in what appears to be a burst of errors with a duration equal to the size of the packet.</p>
Buffer restarts	Number of times the buffer was restarted.
Buffer underflows	Number of times the buffer state was less than the minimum buffer setting.
Buffer overflows	Number of times the buffer reached the maximum set threshold.

**Table 68: CTP Bundle Runtime State and Counters in the CTP Menu (Continued)**

Field Name	Field Description
Buffer starves	Indicates an exceeded threshold. The CTP device is designed to tolerate strings of consecutive missing packets without the loss of bit count integrity. The number of packets is configurable; the default is five. Exceeding this threshold is called a starvation, and a counter is incremented each time this event occurs.
Buffer max samples	Largest buffer sample observed.
Buff Max/Avg/Min	Maximum, average, and minimum buffer sizes observed.
Buff Last Minute	Maximum, average, and minimum buffer sizes observed in the last minute.
Last counter clear	Indicates the last time that the system counters were reset.  This feature is supported on CTPOS release 6.6R3 and later for CESoPSN bundles created on CTP2000 series.

## Displaying the NetRef Node Synchronization Information (CTP Menu)

To display the configured NetRef node synchronization details using the CTP Menu:

1. From the Main Menu, select **2) Node Synchronization**
2. Select **8) Query Node Sync Status** to view NetRef node details.

The Slave Node Sync query displays the IP address of that primary node to which it is locked. The query output also displays the IP addresses of all the configured primaries along with their priorities. When a switchover of the primary nodes occurs, the client node sync query displays the IP address of the switched primary node. In the following example, the client node is locked to the primary (10.216.118.73).

```
Node Synchronization Info
=====
Reference in use:   Slave of 10.216.118.86
NetRef State:      Maintain (last adj -0.217 ppm)
```



```

NetRef Masters:
  10.216.118.73 Priority 1
  10.216.118.86 Priority 2
  10.216.118.90 Priority 3
  10.216.118.88 Priority 4

```

When the primary (10.216.118.73) goes down, the client node locks to the next highest priority primary (10.216.118.86) as illustrated in the following example:

```

Please select a number from the following list:
-----

```

```

0) Back to Previous Menu
1) 1st Priority, Reference 0: Disabled
2) 2nd Priority, Reference 1: Disabled
3) 3rd Priority, Reference 2: Disabled
4) 4th Priority, Reference 3: Disabled
5) 5th Priority, Reference 4: Disabled
6) NetRef:                Slave
7) 32 kHz Ref Output:     NO
8) Query Node Sync Status
9) Measure Ref Inputs
10) Calibrate Node to Current Reference
----- Your choice [6]: 8

```

```

Node Synchronization Info
=====

```

```

Reference in use:  Slave of 10.216.118.86
NetRef State:     Maintain (last adj -0.217 ppm)

```

```

NetRef Masters:
  10.216.118.73 Priority 1
  10.216.118.86 Priority 2
  10.216.118.90 Priority 3
  10.216.118.88 Priority 4

```

[Table 69 on page 234](#) describes the fields corresponding to the configured NetRef nodes and synchronization details displayed in the output.

Table 69: Display of Node Synchronization Details for NetRef in the CTP Menu

Field Name	Field Description
Reference in use	Displays the IP address of the NetRef primary node that is being referenced and used by the client or backup node.
NetRef State	<p>Displays the NetRef state, such as <b>Maintain</b>, <b>Aggressive</b>, <b>Starvation</b>, or <b>Wait</b>. Also, this field displays the number of packets per minute, which when reached, causes the clocking algorithm to change, and which constrains the frequency adjustments to the adaptive clock.</p> <p>If all the four primary nodes goes down, the NetRef state remains in <b>Starvation</b> state and no switching will take place. When the NetRef state of the client node is <b>Maintain</b> and the primary goes down, the client node is unable to receive the packets within the last 20 seconds. Therefore, the NetRef state of the client node moves from <b>Maintain</b> state to <b>Starvation</b> state and switching takes place. When the NetRef state of the client node is <b>Aggressive</b> and the primary goes down, the client node is unable to receive the packets within the last 20 seconds. Therefore, the NetRef state of the client node transitions from <b>Aggressive</b> state to <b>Starvation</b> state and switching will take place.</p>
<b>NetRef Masters</b>	
Priority 1	Displays the IP address of the NetRef primary node assigned with priority 1.
Priority 2	Displays the IP address of the NetRef primary node assigned with priority 2.
Priority 3	Displays the IP address of the NetRef primary node assigned with priority 3.
Priority 4	Displays the IP address of the NetRef primary node assigned with priority 4.

## Displaying Running CTP Bundle Configuration, State, and Counters (CTPView)

This topic describes how to display the running configuration of your bundle, along with the state and various counters.

Before you begin:

- Log in to the CTPView software at least at the Net\_Admin level.
- Connect the CTPView server to the CTP device for which you want to change the status of the bundles.

To view information about the bundle:

1. In the side pane, select **Bundle > Runtime Query**.
2. Run your mouse over the **MouseOver to Display and Select Bundles to Display** bar.
3. In the table of bundles, select the bundles that you want to view, and click **Display Selected Bundles**. To select multiple bundles, hold down the **CTRL** key.

The configuration of the bundle or bundles appears followed by the runtime state and counters.

[Table 70 on page 235](#) describes the fields in the state and counters sections of the display.

The signaling configuration appears only if you changed the signaling configuration from the default configuration.

**Table 70: CTP Bundle Runtime State and Counters in CTPView**

Field Name	Field Description
<b>Bundle Config</b>	
Bndl Desc	Displays the description of the bundle, which enables easy identification.
DBase State	Displays whether the bundle is active or disabled.
Remote Addr	Displays the remote IP address.
Remote CID	Displays the remote circuit ID in the range 0-249.
Local CID	Displays the local circuit ID in the range 0-249.
Packet size	Displays the size of IP packets that are created on the interface (T1/E1 or Serial).
Port Speed (kHz)	Displays the port speed in kHz.

**Table 70: CTP Bundle Runtime State and Counters in CTPView (Continued)**

Field Name	Field Description
Buf Max/Set/ Min(ms)	Displays the maximum, running state, and minimum buffer sizes, in terms of milliseconds. The number that you entered varies depending on the interface type and port speed. The set buffer size denotes the buffer size when the circuit enters a running state.
IP Hdr TOS	Displays the ToS byte to be used in IP headers of packets sent from the CTP device to the IP network. The ToS setting is applied to circuits created by the bundle for which the service type is configured.
IP Proto/OAM Port	Displays the port configured for IP protocol and OAM applications.
Port(s) in bundle	Displays the interfaces that are part of the configured bundle.

Table 70: CTP Bundle Runtime State and Counters in CTPView (Continued)

Field Name	Field Description
Bndl Config Flags	<p data-bbox="480 363 987 390">Displays the current configuration of the bundle:</p> <ul data-bbox="480 426 1421 1661" style="list-style-type: none"> <li data-bbox="480 426 1421 562">• PProtTx—Indicates that the packet protector is set to “Send cloned packets to NET”. The CTP device uses cloned packets that it receives when the IP network drops the original packet. If the device receives both the original and cloned packets, it ignores the cloned packet.</li> <li data-bbox="480 598 1421 735">• PProtRx—Indicates that the packet protector is set to “Expect cloned packets from NET”. The CTP device uses cloned packets that it receives when the IP network drops the original packet. If the device receives both the original and cloned packets, it ignores the cloned packet.</li> <li data-bbox="480 770 1421 907">• PProtTx PProtRx—Indicates that the packet protector is set to “Send &amp; expect cloned packets”. The CTP device sends duplicated packets over the IP network. The CTP device uses cloned packets that it receives when the IP network drops the original packet.</li> <li data-bbox="480 942 1421 1079">• PProtTxDel—Indicates that the packet protector is set to “Send delayed cloned packets to NET”. The CTP device sends duplicated packets after the interpacket delay of the circuit.</li> <li data-bbox="480 1115 1421 1251">• PProtTxDel PProtRx—Indicates that the packet protector is set to “Send delayed &amp; expect cloned packets”. The CTP device sends duplicated packets after the interpacket delay of the circuit. The CTP device uses cloned packets that it receives when the IP network drops the original packet.</li> <li data-bbox="480 1287 1421 1423">• PProtRxXor—Indicates that the packet protector is set to “Expect cloned XOR packets”. The CTP device uses cloned XOR packets that it receives when the IP network drops the original packet to regenerate the missing packet. If the device receives both the original and cloned XOR packets, it ignores the cloned packet.</li> <li data-bbox="480 1459 1421 1596">• PProtTxXor PProtRxXor—Indicates that the packet protector is set to “Send &amp; expect cloned XOR packets”. The CTP device sends duplicated XOR packets over the IP network. The CTP device uses cloned XOR packets that it receives to regenerate missing packets when the IP network drops the original packet.</li> <li data-bbox="480 1631 1421 1661">• PProtTxXor—Indicates that the packet protector is set to “Send cloned XOR packets”. The CTP device sends duplicated XOR packets over the IP network.</li> </ul>
<b>Bundle State</b>	

Table 70: CTP Bundle Runtime State and Counters in CTPView (Continued)

Field Name	Field Description
Run State	<p data-bbox="480 363 899 390">Displays the current state of the bundle:</p> <ul style="list-style-type: none"> <li data-bbox="480 426 829 453">• <b>DISABLD</b>—Bundle is disabled.</li> <li data-bbox="480 489 1354 552">• <b>No Sync</b>—The local CTP device is not able to communicate with the remote CTP device.</li> <li data-bbox="480 588 1406 651">• <b>In Sync</b>—The local CTP device is communicating properly with the remote device, but data is not flowing to the interface.</li> <li data-bbox="480 686 1411 749">• <b>Running</b>—The local CTP device is communicating and is synchronized with the remote CTP device. The circuit is established between the bundles.</li> <li data-bbox="480 785 1268 812">• <b>Eval</b>—The bundle is in the transition state between No Sync and In Sync.</li> <li data-bbox="480 848 1390 953">• <b>TooSlow</b>—Encountered when the bundle is configured for all clocking to be done by the external transmit timer (TT) clock. The error occurs when either no clock is provided by the external device or the rate is different from the configured rate.</li> <li data-bbox="480 989 1382 1094">• <b>TooFast</b>—Encountered when the bundle is configured for all clocking to be done by the external TT clock. The error occurs when either no clock is provided by the external device or the rate is different from the configured rate.</li> <li data-bbox="480 1129 1232 1157">• <b>TtFAIL</b>—The TT differs from the configured value by more than 1/16.</li> <li data-bbox="480 1192 1365 1297">• <b>MisCfg</b>—A misconfiguration of the bundles between the local and remote devices prevents the circuit from being brought up. For example, incorrectly configured IP addresses and mismatched speeds.</li> <li data-bbox="480 1333 1390 1396">• <b>CfgFail</b>—The configuration of the bundle cannot be supported. If you encounter this error, delete the bundle and create a new bundle.</li> <li data-bbox="480 1432 1089 1459">• <b>AutoWait</b>—The bundle is waiting for the TT to stabilize.</li> </ul>

Table 70: CTP Bundle Runtime State and Counters in CTPView (Continued)

Field Name	Field Description
Port Runtime Flags	<p data-bbox="480 363 1105 390">Displays the current configuration of BERTs and serial loops.</p> <ul data-bbox="480 426 1406 1192" style="list-style-type: none"> <li data-bbox="480 426 1406 632">• Inactive—No activity is detected on the serial input. The activity detector checks the serial input line every 500 milliseconds for any transitions on the line. Port Run Time flag of the serial CTP bundle shows the status as Inactive if no activity is detected on the serial input line. This flag is displayed only when the serial input line is inactive, which is an abnormal condition. No such flag is displayed if the serial input line is active.</li> <li data-bbox="480 663 1406 726">This flag applies only to a serial port that has a T1E1 interface module installed and is in use. It does not apply to ports on a T1E1 card.</li> <li data-bbox="480 762 1117 789">• BertFrmNet—Used to receive the BERT from the network</li> <li data-bbox="480 831 1110 858">• BertFromIf—Used to receive the BERT from the interface</li> <li data-bbox="480 894 1377 957">• BertToNet—Transmit BERT for this port is active and is sending the network bound data, thereby interrupting the normal data path from the interface.</li> <li data-bbox="480 999 1414 1062">• BertToIf—Transmit BERT for this port is active and is sending the interface bound data, thereby interrupting the normal data path from the IP network.</li> <li data-bbox="480 1098 1102 1125">• LoopToNet—Used to loop back the BERT to the network</li> <li data-bbox="480 1161 1040 1188">• LoopToIf—Used to loop back the BERT to interface</li> </ul>
IRIG-B Run Flags	<p data-bbox="480 1266 992 1293">Displays the current status of the IRIG-B runtime</p> <ul data-bbox="480 1329 1252 1556" style="list-style-type: none"> <li data-bbox="480 1329 1187 1356">• TxIpSync—Transmit mode is in sync with the remote CTP device.</li> <li data-bbox="480 1392 1252 1419">• TxSyncLost—Transmit mode is not in sync with the remote CTP device.</li> <li data-bbox="480 1455 1182 1482">• RxIpSync—Receive mode is in sync with the remote CTP device.</li> <li data-bbox="480 1518 1247 1545">• RxSyncLost—Receive mode is not in sync with the remote CTP device.</li> </ul>

Table 70: CTP Bundle Runtime State and Counters in CTPView (Continued)

Field Name	Field Description
T1E1 flags	<p>Appears for bundles on T1/E1 interfaces.</p> <ul style="list-style-type: none"> <li>• LOS—Loss of signal. This could mean that the cable is not attached. When LOS is detected, the CTP device puts the bundle into a loop so that the TX and RX clock are looped to each other.</li> <li>• LOF—Loss of frame.</li> <li>• AIS—Alarm indication signal.</li> <li>• RAI—Remote alarm indication (yellow alarm).</li> <li>• LOF_NB—Fractional T1 only. FPGA framer loss of frame network bound.</li> <li>• LOF_IB - Fractional T1 only. FPGA framer loss of frame interface bound.</li> </ul>
TT (Ext Clock)	<p>Displays the current speed of the transmit timing (TT) clock.</p> <p>The TT measurement is displayed only for a CTP bundle or a SAToP bundle that is attached to a T1E1 port on a T1E1 Daughter Card or a CTP bundle attached to a serial port with clock configuration set to <b>Configured with TT, All Clocked by TT, Adaptive Rate, w/ User Clk (TT)</b>, or <b>Autobaud Rate, w/ User Clk (TT)</b>.</p>
RT (Ext Clock)	<p>Displays the current speed of the receive timing (RT) clock.</p> <p>Appears if the bundle is configured as the DTE, and clocking is set to <b>DTE, All Clocked by Ext Clk (ST/RT)</b>.</p>
Adaptive State	<p>For bundles that are configured as the adaptive end for adaptive clocking, displays the current state of the adaptive clock:</p> <ul style="list-style-type: none"> <li>• Maintain (20 us)</li> <li>• Maintain (968 us)</li> <li>• N/A (Port Not RUNNING)</li> </ul>
Adap Recovered Freq	<p>For bundles that are configured as the adaptive end for adaptive clocking, displays the frequency currently being recovered from the primary end.</p>



Table 70: CTP Bundle Runtime State and Counters in CTPView (Continued)

Field Name	Field Description
Input Signals	Displays the running configuration of input signals.
Output Signals	Displays the running configuration of output signals.
Checked out PPS	<p>Displays packets per second (PPS) for the current bundle, for all running bundles on the CTP device, and the maximum PPS for the CTP device.</p> <p><b>NOTE:</b> For CESoPSN bundle, this field is available only in CTPOS release 7.0 and later.</p>
<b>Port Config</b>	
Port Desc	Displays the description of the port.
Interface type	<p>Displays the type of interface.</p> <p>The type of interface that you select affects the default packet size and buffer sizes for the bundle.</p>
Port Config Flags	<p>Displays the current configuration of the port:</p> <ul style="list-style-type: none"> <li>• T1LoSCheck—Denotes that LOS detection is specified on a T1 port connected to a CTP bundle or a SAToP bundle</li> <li>• E1LoSCheck—Denotes that LOS detection is specified on a E1 port connected to a CTP bundle or a SAToP bundle</li> <li>• NoRdReclk flag—Signifies that the redundancy receiving (RX) clock is disabled. The NoRdReclk flag is also displayed because this flag is default enabled for a T1/E1 port, whereas it is usually not enabled for a serial port.</li> </ul> <p>When you run the bundle query for CTP bundles and SAToP bundles, the T1E1 port type displays port configuration flags that are relevant to a T1E1 port.</p>
Framing type	<p>Displays the framing type for T1 interfaces.</p> <ul style="list-style-type: none"> <li>• ESF</li> <li>• D4</li> </ul>

Table 70: CTP Bundle Runtime State and Counters in CTPView (Continued)

Field Name	Field Description
Redundancy Config	<p>Displays the configured redundancy mode.</p> <ul style="list-style-type: none"> <li>• Disable—Y-cable redundancy is not enabled on this port.</li> <li>• eXclusive OR (XOR)—Redundancy is enabled. In this mode the Y cable is active only if the port is in RUNNING state and the serial port on the Y-cable link is not in RUNNING state. If both bundles are RUNNING, the Y cable remains inactive on both the ports.</li> <li>• ReVeRT (RVRT)—When you select this mode, a primary and a secondary path is enabled. The primary path drives the cable when its bundle is in RUNNING state, independent of the state of the secondary path. The secondary path is activated when the primary path is offline. Whenever the primary path comes back online, the path is switched back to the primary path.</li> <li>• NOnReVert (NORV)—When you select this mode, the circuit is not switched back to primary when the primary path comes back online after switching to secondary path. The circuit is switched to the primary path only when the secondary path fails.</li> <li>• Signal (SIG)—The primary path is activated only if the secondary CTS output is inactive. When CTS is active, secondary drives cable.</li> </ul>
Primary/Secondary	<p>Specifies whether it is a primary and a backup bundle. When the software link is enabled and link partners are specified, the software verifies that there is a matched primary and backup pair.</p>

Table 70: CTP Bundle Runtime State and Counters in CTPView (Continued)

Field Name	Field Description
Pri/Sec Link Type	<p>Specifies the link types for primary and back up bundle.</p> <ul style="list-style-type: none"> <li>• H/W link—When enabled, the Y-cable redundancy is supported only on serial ports, and the link between ports is a hardware signaling connection over a special Y cable that uses the output to cable(TM) and the input from cable(RL) to communicate redundancy state between port pairs, by using keepalive pulses. Its operation is similar to the default operation of the redundancy feature in CTPOS Release 6.5 and earlier.</li> <li>• S/W link—Allows Y-cable port pairs to maintain contact with each other by means of OAM packets instead of using a hardware signaling path. The software link has the following advantages: <ul style="list-style-type: none"> <li>• The software link does not require a special signaling hardware, which means that Y-cable redundancy is supported on T1E1 ports as well as serial ports with a special Y cable. Serial ports can get TM/RL signals for user applications.</li> <li>• Software or OAM link packets can check link partners and identify configuration errors. They can also differentiate between dead and alive states.</li> </ul> </li> </ul>
IP Address	<p>Specifies an IP address for the other port of the redundant primary and backup pair.</p>
Line Buildout	<p>Displays the line buildout for T1 interfaces.</p> <ul style="list-style-type: none"> <li>• 0) ~133 ft</li> <li>• 1) ~266 ft</li> <li>• 2) ~399 ft</li> <li>• 3) ~533 ft</li> <li>• 4) ~655 ft</li> <li>• 5) -7.5dB CSU</li> <li>• 6) -15dB CSU</li> <li>• 7) -22.5dB CSU</li> </ul>

Table 70: CTP Bundle Runtime State and Counters in CTPView (Continued)

Field Name	Field Description
Clock Source	<p>Displays the type of clocking for the port.</p> <ul style="list-style-type: none"> <li>• CTP is Clock Source—The PBX either returns the clock received from the CTP or it returns a clock that is traceable to the same source as the CTP node clock reference. You typically use this configuration when you configure the CTP device with a clock reference input.</li> <li>• CTP is Loop Timed—The PBX provides the clock and the CTP returns the same clock to the PBX. You typically use this configuration when the PBX has the more accurate clock source. You can configure the far end of the circuit with adaptive clocking to recover this clock if necessary.</li> <li>• CTP is Clock Source (Adaptive End)—The PBX returns the clock received from the CTP, and the CTP uses the adaptive recovered clock. You typically use this configuration when the CTP does not have a reference input and the PBX typically requires clock from the distant PBX.</li> </ul> <p>On CTP150 devices, If you set clocking to <b>CTP is Clock Source (Adaptive End)</b>, the first bundle activated on the interface is assigned as the adaptive primary bundle on which the transmit clock is adjusted. This bundle is also the last bundle to be deactivated on the interface.</p>
Port Speed (kHz)	Displays the port speed in kHz.

#### Node Sync Info State

**NOTE:** This section is displayed only if the `cmd bndl X qry dbg_cstm1` option is selected from the **Runtime Query Selection** list under the **GUI Settings** pane.

PLL Lock/Ref	Indicates whether the phase lock loop (PLL) is currently locked to a valid reference (YES) or whether no reference is available (NO).
PLL Monitor Runtime	Indicates the time (in seconds) that the PLL has been monitored since the last restart of the CTP or reconfiguration of the CTP reference.
PLL Monitor Loss	Indicates the number of seconds during the PLL monitor runtime that the PLL has not been locked.

Table 70: CTP Bundle Runtime State and Counters in CTPView (Continued)

Field Name	Field Description
<b>Bundle Counters</b>	
I/F bound packets	Packets received from the IP network destined for the bundle.
NET bound packets	Packets created by the bundle and sent to the IP network.
Late pkts	Packets that were delivered to the CTP device, but arrived too late to be processed. Significant numbers of late packets indicate that the size of the buffer needs to be increased.
Missing pkts	<p>Packets that were not delivered to the CTP in time to process out the serial interface because they were either late or dropped by the IP network.</p> <p>Each time a packet is missed, the data fill pattern specified in the advanced port options is substituted for data in the missed packet. The substitution maintains the bit count integrity of the data sent to the DTE or encryptor, but results in what appears to be a burst of errors with a duration equal to the size of the packet.</p>
Buffer restarts	Number of times the buffer was restarted.
Buffer underflows	Number of times that the average buffer state was less than the minimum buffer setting.
Buffer overflows	Number of times that the buffer state exceeded the maximum buffer setting.
Buffer starves	Indicates an exceeded threshold. The CTP device is designed to tolerate strings of consecutive missing packets without the loss of bit count integrity. The number of packets is configurable; the default is five. Exceeding this threshold is called a starvation, and a counter is incremented each time this event occurs.
Buffer max samples	Largest buffer sample observed.
Buff Max/Avg/Min	Maximum, average, and minimum buffer sizes observed.
Buff Last Minute	Maximum, average, and minimum buffer sizes observed in the last minute.

**Table 70: CTP Bundle Runtime State and Counters in CTPView (Continued)**

Field Name	Field Description
BERT running sec	Number of seconds the current update has been running.
BERT sync sec	Number of seconds that the local CTP device has been in sync with the remote CTP device.
BERT error sec	Number of seconds during which there were errors.
BERT in sync	Shows whether the CTP device is currently in sync with the remote CTP device
Last counter clear	Indicates the last time that the system counters were reset.  This feature is supported on CTPOS release 6.6R3 and later for CESoPSN bundles created on CTP2000 series.

# Monitoring Packet Creation and Reception and Packet Delay

## IN THIS CHAPTER

- Using SCC Counts to Monitor Packet Creation and Reception for CTP Bundles (CTP Menu) | 247
- Using Buffer Sampling to Monitor Packet Delay for CTP Bundles (CTP Menu) | 249
- Searching for Bundles Based on Bundle Description from CTPView | 250

## Using SCC Counts to Monitor Packet Creation and Reception for CTP Bundles (CTP Menu)

Serial Communications Controller (SCC) counts provide detail about packet creation and reception for a CTP bundle.

You cannot display SCC counts in CTPView.

To display SCC counts using the CTP Menu:

1. From the CTP Main Menu, select **1) Bundle Operations**.
2. Select the type of bundle.
3. Select a bundle from the list.
4. Select **8) Runtime Diags**.
5. Select **7) SCC Counts**.

A list of packet counters appears. [Table 71 on page 247](#) describes the counters.

**Table 71: Statistics for Packet Creation and Reception for CTP Bundles in the CTP Menu**

Field Name	Description
Pkts to NET from I/F	Packets to network from interface. Number of packets that were sent to the IP network from the interface.

Table 71: Statistics for Packet Creation and Reception for CTP Bundles in the CTP Menu *(Continued)*

Field Name	Description
Pkts to NET ints	Packets to network interrupts. Number of packets destined for the IP network that were processed by the software.
Pkts to I/F from NET	Packets to interface from network. Number of packets that were sent to the interface from the IP network.
Pkts to I/F ints	Packets to interface interrupts. Number of packets destined for the interface that were processed by the software driver.
Pkts to I/F missing	Packets to interface missing. Number of packets destined for the interface that were not available when the data was needed. Unavailability can be caused by a dropped packet in the IP network or a delayed packet considered late by the CTP device according to the current buffer settings and state.
Pkts to I/F late	Packets to interface late. Number of packets destined for the serial interface that were not available when the data was needed. Unavailability can be caused by a dropped packet in the IP network or a delayed packet considered late by the CTP device according to the current buffer settings and state.
Pkts to I/F recenter cnt	<p>Packets to interface recenter count. Number of buffer recenters since the last time statistics were cleared. Recenters are caused by either buffer underflow (buffer depleted) or the buffer exceeding the maximum delay configured for the bundle.</p> <p>Under normal operations, the buffer recenter count should not increment. If the count is incrementing, check both the clocking configuration and the reference clocks being used by the CTP device. For example, if the local and remote ends of the bundle are configured with slightly different rates, buffer recenters will result. If the accuracy or stability of the references is inaccurate, recenters may also occur.</p>
Pkts to I/F underflow cnt	Packets to interface underflow count. Number of times the minimum threshold was reached since the counter was last reset.
Pkts to I/F overflow cnt	Packets to interface overflow count. Number of times the minimum threshold was reached since the counter was last reset.



Table 71: Statistics for Packet Creation and Reception for CTP Bundles in the CTP Menu *(Continued)*

Field Name	Description
Pkts to I/F starve cnt	Packets to interface starvation count. Number of times the CTP device considered the bundle to be in a starvation condition. The CTP receive processor considers a starvation condition to be when a fixed consecutive number of packets are missing from the IP network. During this state, the buffer is recentered. Starvation can occur because of a failure in the IP network or because of a cabling or Ethernet interface problem.

## Using Buffer Sampling to Monitor Packet Delay for CTP Bundles (CTP Menu)

The CTP device uses buffer sampling to monitor packet delay. Buffer samples are based on the amount of time that packets are in the buffer. The time is measured from when a packet arrives from the Ethernet interface to when it is transmitted out the serial interface.

You cannot display buffer sampling in CTPView.

To display buffer for a CTP bundle using the CTP Menu:

1. From the CTP Main Menu, select **1) Bundle Operations**.
2. Select the type of bundle.
3. Select a bundle from the list.
4. Select **8) Runtime Diags**.
5. Select **8) Buffer Query**.

A list of buffer counts appears. [Table 72 on page 249](#) describes the fields in the buffer counts.

Table 72: Buffer Counts for CTP Bundles in the CTP Menu

Field Name	Description
Total Samples	Number of packets measured since the last time the count was cleared.
Smallest Sample	Within the total number of samples, the smallest sample measured in milliseconds. Packets in this sample experienced the most delay.
Average Sample	Within the total number of samples, the average buffer fill, in milliseconds.

Table 72: Buffer Counts for CTP Bundles in the CTP Menu *(Continued)*

Field Name	Description
Largest Sample	Within the total number of samples, the largest sample measured in milliseconds. Packets in this sample experienced the least delay.
Largest Buffer Jitter	Difference between the largest sample measured and the smallest sample measured, in milliseconds. This number corresponds to system packet delay jitter.

## Searching for Bundles Based on Bundle Description from CTPView

You can search for a bundle from the CTPView network monitoring page by using the bundle description as the search criteria.

To search for bundles from the CTPView network monitoring page:

1. In the side pane, select **Network > Monitoring**.  
The Network Monitoring pane is displayed.
2. Run your mouse over the **MouseOver to Search bundles using Bundle description** bar.
3. Enter the search criteria in the search field and click **Search**.  
A list of bundles matching the search criteria is displayed.

### RELATED DOCUMENTATION

*Adding a Bundle (CTP Menu)*

*Adding a Bundle (CTPView)*

# Diagnostic Testing for CTP Bundles Overview

## IN THIS CHAPTER

- [Serial Loops for CTP Bundles Overview | 251](#)
- [BERT Testing for CTP Bundles Overview | 253](#)
- [End-to-End BERT for CTP Bundles Overview | 254](#)

## Serial Loops for CTP Bundles Overview

### IN THIS SECTION

- [Normal Data Flow in the CTP Network | 251](#)
- [Serial Loop to the Serial Interface | 252](#)
- [Serial Loop to the Network | 252](#)

You can use serial loops to diagnose issues in your network. You set up serial loops in the following directions:

- Toward the serial interface and the attached customer device.
- Toward the IP network and the remote customer device.

Serial loops may not run on transparent circuits. The serial loop function connects the SD and RD signals of the interface (in the direction specified), and will work only if a transparent circuit uses the SD and RD signals to transport data.

### Normal Data Flow in the CTP Network

[Figure 17 on page 252](#) shows the normal data flow through the network.

Figure 17: Normal Data Flow

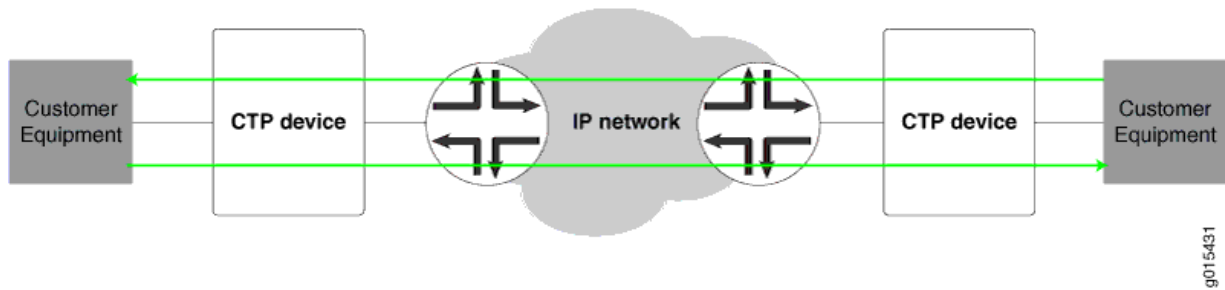

### Serial Loop to the Serial Interface

Figure 18 on page 252 shows the data flow for a serial loop to the interface and the local customer device.

The serial loop toward the interface loops data arriving from the serial interface that is destined for the IP network back to the serial interface. The data is still transmitted from the serial interface to the IP network, but data from the IP network to the serial interface is blocked.

Figure 18: Serial Loop to the Interface

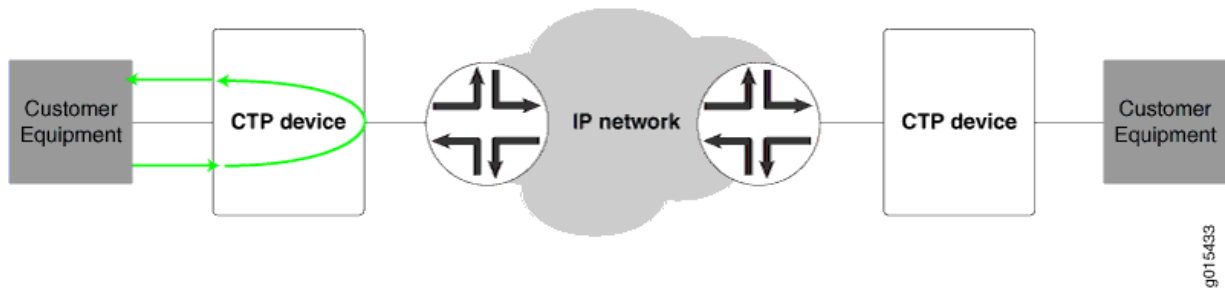

### Serial Loop to the Network

Figure 19 on page 253 shows the data flow for a serial loop toward the network.

Serial loops toward the IP network loops data arriving from the IP network that is destined for the serial interface back to the IP network and the remote customer device. The data is still transmitted from the IP network to the serial interface, but data from the serial interface to the IP network and the remote customer device is blocked.

Figure 19: Serial Loop to the Network

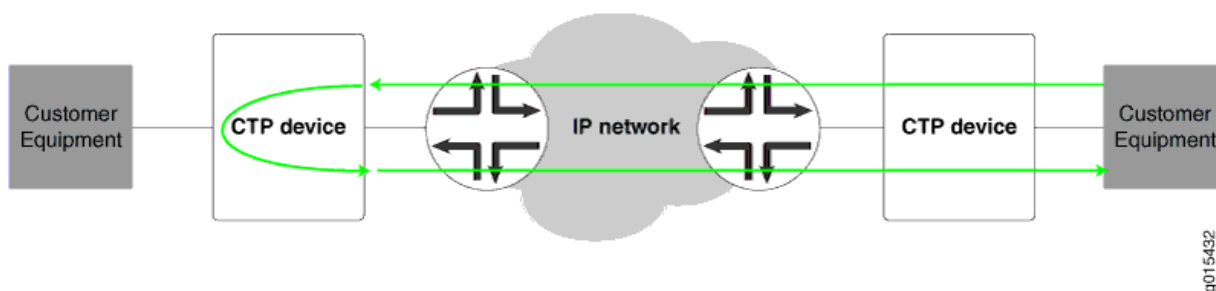

## RELATED DOCUMENTATION

[Configuring Serial Loops for CTP Bundles \(CTP Menu\) | 256](#)

[Configuring Serial Loops for CTP Bundles \(CTPView\) | 257](#)

## BERT Testing for CTP Bundles Overview

The CTP series provides Bit Error Rate Tests (BERT) for bundles. Each bundle can have a BERT transmitter and receiver that can transmit and receive a pseudorandom sequence of data using a pattern that you specify. You can set up the BERT to transmit the data sequence toward the serial interface or toward the IP network. User data is replaced with the data sequence in the direction that you select.

You can set up BERTs in the following directions:

- Toward the serial interface and the attached customer device.
- Toward the IP network and the remote customer device. This configuration is called end-to-end BERT.

BERTs do not run on bundles that use transparent encoding or on fractional T1/E1 bundles.

## RELATED DOCUMENTATION

[Configuring BERT Testing for CTP Bundles \(CTPView\) | 260](#)

[Configuring BERT Testing for CTP Bundles \(CTP Menu\) | 258](#)

[Displaying BERT Status and Counters for CTP Bundles \(CTPView\) | 264](#)

[Displaying BERT Status and Counters for CTP Bundles \(CTP Menu\) | 262](#)

## End-to-End BERT for CTP Bundles Overview

This topic provides an overview of how to set up end-to-end BERT for CTP bundles.

Figure 20 on page 254 shows the normal data flow through the network. BERT is disabled.

Figure 20: Normal Data Flow

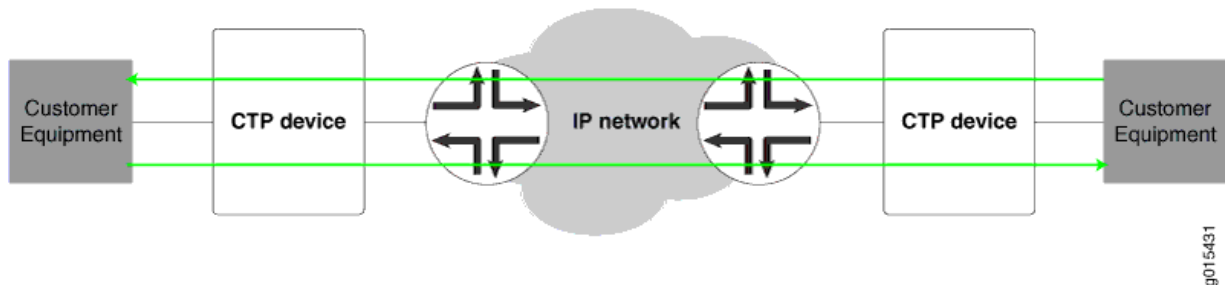

To set up end-to-end BERTS for CTP bundles:

1. To send BERT transmissions to the network, start BERT injection on each CTP bundle toward the IP network as shown in Figure 21 on page 254.

Figure 21: BERT Transmission to the Network

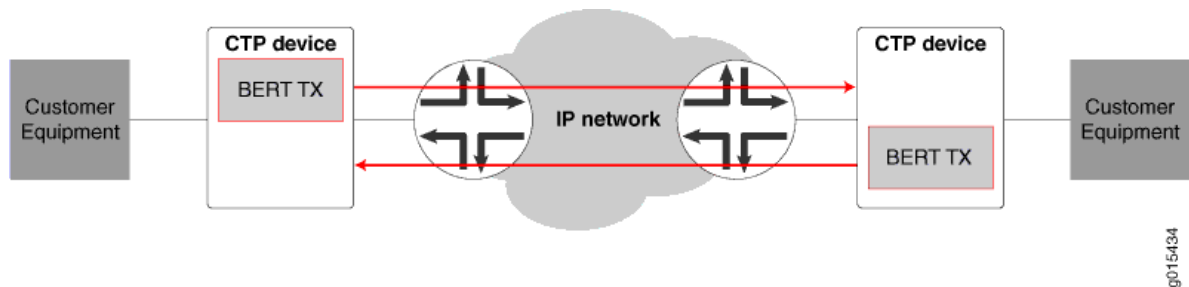

2. To receive BERT reception from the network, start BERT reception on each bundle from the IP network as shown in Figure 22 on page 255.

Figure 22: End-to-End BERT Reception

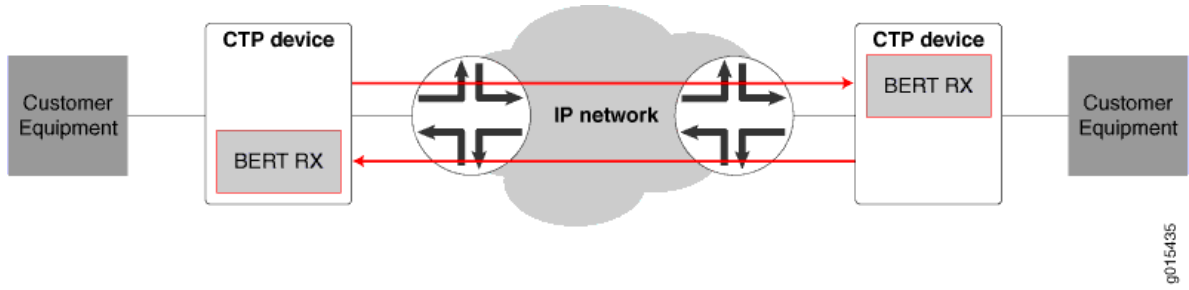

The result is that end-to-end BERT transmission and reception are running as shown in [Figure 23 on page 255](#).

Figure 23: End-to-End BERT Transmission and Reception

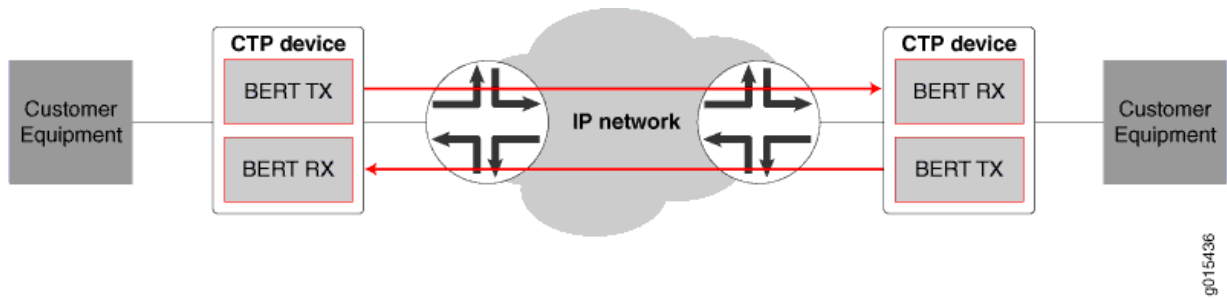

# Configuring and Displaying Diagnostic Testing for CTP Bundles

## IN THIS CHAPTER

- Configuring Serial Loops for CTP Bundles (CTP Menu) | 256
- Configuring Serial Loops for CTP Bundles (CTPView) | 257
- Configuring BERT Testing for CTP Bundles (CTP Menu) | 258
- Configuring BERT Testing for CTP Bundles (CTPView) | 260
- Displaying BERT Status and Counters for CTP Bundles (CTP Menu) | 262
- Displaying BERT Status and Counters for CTP Bundles (CTPView) | 264

## Configuring Serial Loops for CTP Bundles (CTP Menu)

Serial loops will run on transparent circuits only if the transparent circuits use the SD and RD signals to transport data.

To configure serial loops with the CTP Menu:

1. From the CTP Main Menu, select **1) Bundle Operations**.
2. Select **1) CTP**.
3. Select a bundle from the list.
4. Select **8) Runtime Diags**.
5. Select **1) Serial Loop**.
6. Configure the Serial Loop option as described in [Table 73 on page 257](#).



Table 73: Serial Loop Parameter Settings in the CTP Menu

Field	Function	Your Action
Serial Loop	Specifies the direction of the serial loop or removes the serial loop.	<p>Select one:</p> <ul style="list-style-type: none"> <li>• None—Removes the serial loop.</li> <li>• To NET—Creates a loop toward the network. Data arriving from the IP network destined for the serial interface is looped back to the IP network and remote customer device. The data is still transmitted from the IP network to the serial interface, but data from the serial interface to the IP network and remote device is blocked.</li> <li>• To I/F—Creates a loop toward the customer device attached to the serial interface. Data arriving from the serial interface that is destined for the IP network is looped back to the serial interface. The data is still transmitted from the serial interface to the IP network, but data from the IP network to the serial interface is blocked.</li> </ul>

## RELATED DOCUMENTATION

[Serial Loops for CTP Bundles Overview](#) | 251

## Configuring Serial Loops for CTP Bundles (CTPView)

Serial loops will run on transparent circuits only if the transparent circuits use the SD and RD signals to transport data.

To configure serial loops using CTPView:

1. In the side pane, select **Bundle > Diagnostics**.
2. Click **Bit Error Rate Tester**.
3. Run your mouse over the **MouseOver to Select a Port to Display** bar.  
A list of bundles configured on the CTP device appears.
4. In the table of bundles, select the bundle for which you want to configure a serial loop.
5. Configure the serial loop as described in [Table 74 on page 258](#).

Table 74: Serial Loop Parameter Settings in CTPView

Field	Function	Your Action
Serial Loop	Specifies the direction of the serial loop or removes the serial loop.	<p>Select one:</p> <ul style="list-style-type: none"> <li>• None—Removes the serial loop.</li> <li>• To Net—Creates a loop toward the network. Data arriving from the IP network destined for the serial interface is looped back to the IP network and remote customer device. The data is still transmitted from the IP network to the serial interface, but data from the serial interface to the IP network and remote device is blocked.</li> <li>• To I/F—Creates a loop toward the customer device attached to the serial interface. Data arriving from the serial interface that is destined for the IP network is looped back to the serial interface. The data is still transmitted from the serial interface to the IP network, but data from the IP network to the serial interface is blocked.</li> </ul>

## RELATED DOCUMENTATION

[Serial Loops for CTP Bundles Overview](#) | 251

## Configuring BERT Testing for CTP Bundles (CTP Menu)

BERTs do not run on bundles that use transparent encoding or on fractional T1/E1 bundles.

To configure BERTs with the CTP Menu:

1. From the CTP Main Menu, select **1) Bundle Operations**.
2. Select **1) CTP**.
3. Select a bundle from the list.
4. Select **8) Runtime Diags**.
5. Configure the BERT options as described in [Table 75 on page 259](#).

Table 75: BERT Parameter Settings in the CTP Menu

Field	Function	Your Action
BERT Injection	<p>Specifies whether this bundle acts as the BERT transmitter. If the bundle is the BERT transmitter, specifies the direction in which it transmits test data.</p>	<p>Select one:</p> <ul style="list-style-type: none"> <li>• Disabled—Disables BERT transmission on this bundle.</li> <li>• Tx to NET—BERT pattern is injected toward the IP network. User data transmitted in the direction of the IP network is replaced with the BERT pattern.</li> <li>• Tx to I/F—BERT pattern is injected toward the serial interface. User data transmitted toward the serial interface is replaced with the BERT pattern.</li> </ul>
BERT Reception	<p>Specifies whether this bundle acts as the BERT receiver. If the bundle is the BERT receiver, specifies the direction from which it receives test data.</p> <p>The BERT receiver does not disrupt the existing data flow in either direction.</p>	<p>Select one:</p> <ul style="list-style-type: none"> <li>• Disabled—Disables BERT reception on this bundle.</li> <li>• Rx from NET—BERT pattern is received from the network.</li> <li>• Rx from I/F—BERT pattern is received from the interface.</li> </ul>

Table 75: BERT Parameter Settings in the CTP Menu *(Continued)*

Field	Function	Your Action
BERT Pattern	<p>Specifies the type of BERT pattern.</p> <p>BERT patterns are compatible with the external BERT equipment that you are using. All patterns except 2^31-1 are compatible with the Fireberd 6000.</p> <p>When you set up a bidirectional end-to-end BERT, you must configure the same pattern on both bundles.</p>	<p>Select one:</p> <ul style="list-style-type: none"> <li>• MARK</li> <li>• ALT</li> <li>• 511</li> <li>• 2047</li> <li>• 2^15-1</li> <li>• 2^20-1</li> <li>• 2^23-1</li> <li>• 2^29-1</li> <li>• 2^31-1</li> <li>• 2^4-1</li> </ul>
BERT Error Inject	The BERT transmitter injects an error into the pattern to verify that an end-to-end BERT has been established.	Enter 5) <b>BERT Error Inject</b> to inject an error into the pattern.

## RELATED DOCUMENTATION

[BERT Testing for CTP Bundles Overview | 253](#)

[Displaying BERT Status and Counters for CTP Bundles \(CTP Menu\) | 262](#)

## Configuring BERT Testing for CTP Bundles (CTPView)

BERTs do not run on bundles that use transparent encoding or on fractional T1/E1 bundles.

To configure BERTs with CTPView:

1. In the side pane, select **Bundle > Diagnostics**.

2. Click **Bit Error Rate Tester**.
3. Run your mouse over the **MouseOver to Select a Port to Display** bar.  
A list of bundles configured on the CTP device appears.
4. In the table of bundles, select the bundle for which you want to configure BERTs.
5. Configure the BERT parameters as described in [Table 76 on page 261](#).

**Table 76: BERT Parameter Settings in CTPView**

Field	Function	Your Action
BERT Injection	Specifies whether this bundle acts as the BERT transmitter. If the bundle is the BERT transmitter, specifies the direction in which it transmits test data.	Select one: <ul style="list-style-type: none"> <li>• Disabled—Disables BERT transmission on this bundle.</li> <li>• Tx to Net—BERT pattern is injected toward the IP network. User data transmitted in the direction of the IP network is replaced with the BERT pattern.</li> <li>• Tx to I/F—BERT pattern is injected toward the serial interface. User data transmitted in the direction of the IP network is replaced with the BERT pattern.</li> </ul>
BERT Reception	Specifies whether this bundle acts as the BERT receiver. If the bundle is the BERT receiver, specifies the direction from which it receives test data.  The BERT receiver does not disrupt the existing data flow in either direction.	Select one: <ul style="list-style-type: none"> <li>• Disabled—Disables BERT reception on this bundle.</li> <li>• Rx from Net—BERT pattern is received from the network.</li> <li>• Rx from I/F—BERT pattern is received from the interface.</li> </ul>

Table 76: BERT Parameter Settings in CTPView (Continued)

Field	Function	Your Action
Patterns	<p>Specifies the type of BERT pattern.</p> <p>BERT patterns are compatible with the external BERT equipment that you are using. All patterns except 2<sup>31</sup>-1 are compatible with the Fireberd 6000.</p> <p>When you set up a bidirectional end-to-end BERT, you must configure the same pattern on both bundles.</p>	<p>Select one:</p> <ul style="list-style-type: none"> <li>• MARK</li> <li>• ALT</li> <li>• 511</li> <li>• 2047</li> <li>• 2<sup>15</sup>-1</li> <li>• 2<sup>20</sup>-1</li> <li>• 2<sup>23</sup>-1</li> <li>• 2<sup>29</sup>-1</li> <li>• 2<sup>31</sup>-1</li> <li>• 2<sup>4</sup>-1</li> </ul>
Update Rate	Specifies the rate at which CTPView checks the status of the BERT and updates the synchronization status and counters.	Select the number of seconds.
Inject Error	The BERT transmitter injects an error into the pattern to verify that an end-to-end BERT has been established.	Click the button to inject an error into the pattern. The Error Cnt should increment by one.

#### RELATED DOCUMENTATION

[BERT Testing for CTP Bundles Overview | 253](#)

[Displaying BERT Status and Counters for CTP Bundles \(CTPView\) | 264](#)

## Displaying BERT Status and Counters for CTP Bundles (CTP Menu)

To display BERT status and counters with the CTP Menu:

1. From the CTP Main Menu, select **1) Bundle Operations**.
2. Select the type of bundle.
3. Select a bundle from the list.
4. Select **8) Runtime Diags**.
5. Select **6) BERT counts**.
6. [Table 77 on page 263](#) describes the BERT status and counters.

**Table 77: BERT Status and Counters in the CTP Menu**

Field Name	Description
BERT Running time	Number of seconds the test has been running since BERT statistics were cleared.
Sync Seconds	Number of seconds that the local CTP device has been in sync with the remote CTP device.
Errored Seconds	Number of seconds during which there were errors.
Error Count	Number of errors found since BERT statistics were cleared.
Sync Loss Count	Number of times synchronization was lost.
Currently in SYNC	Shows whether the local CTP device is currently in sync with the remote device. <ul style="list-style-type: none"> <li>• YES—The local CTP device is in sync with the remote device.</li> <li>• NO—The local CTP device is not in sync with the remote device.</li> </ul>

## RELATED DOCUMENTATION

[BERT Testing for CTP Bundles Overview | 253](#)

[Configuring BERT Testing for CTP Bundles \(CTP Menu\) | 258](#)

## Displaying BERT Status and Counters for CTP Bundles (CTPView)

This topic describes how to display BERT status and counters.

Before you begin:

- Log in to the CTPView software at least at the Net\_Admin level.
- Connect the CTPView server to the CTP device for which you want to change the status of the bundles.

To view BERT status and counters:

1. In the side pane, select **Bundle > Diagnostics**.
2. Click **Bit Error Rate Tester**.
3. Run your mouse over the **MouseOver to Select a Port to Display** bar.  
A list of bundles configured on the CTP device appears.
4. In the table of bundles, select the bundle that you want to view.  
The BERT configuration and counters page appears. [Table 78 on page 264](#) describes the status and the counter fields.

**Table 78: BERT Status and Counters in CTPView**

Field Name	Field Description
Sync or Lost	Shows whether the local CTP device is currently in sync with the remote device. <ul style="list-style-type: none"> <li>• If the Sync indicator is green, the local CTP device is in sync with the remote device.</li> <li>• If the Lost indicator is red, the local CTP device is not in sync with the remote device.</li> </ul>
Error Free %	Percentage of time since BERT statistics were cleared that there were no errors.
Error Cnt	Number of errors found since BERT statistics were cleared.
Error Sec	Number of seconds during which there were errors.
Sync Sec	Number of seconds that the local CTP device has been in sync with the remote CTP device.
Availability%	Percentage of time since BERT statistics were cleared that the circuit has been available.



**Table 78: BERT Status and Counters in CTPView (Continued)**

Field Name	Field Description
Run Sec	Number of seconds the current update has been running.
SLoss Cnt:	Number of times synchronization was lost.
Last Clr	Time since the BERT counters were cleared.

**RELATED DOCUMENTATION**

[BERT Testing for CTP Bundles Overview | 253](#)

[Configuring BERT Testing for CTP Bundles \(CTPView\) | 260](#)

# Reducing the Number of SNMP Traps Generated for Late and Missing Packets

## IN THIS CHAPTER

- Reducing the Number of SNMP Traps Generated for Late and Missing Packets (CTP Menu) | 266

## Reducing the Number of SNMP Traps Generated for Late and Missing Packets (CTP Menu)

This feature is supported on SAToP and CTP bundles.

To reduce the number of SNMP traps generated for late and missing packets with the CTP Menu:

1. From the CTP Main Menu, select **1) Bundle Operations**.
2. Select **1) CTP** or **2) SAToP**.
3. Select a bundle from the list.
4. Select **12) Missing Pkts generate snmp trap** and configure the parameter as described in [Table 79 on page 266](#).
5. Select **13) Late Pkts generate snmp trap** and configure the parameter as described in [Table 79 on page 266](#).

**Table 79: SNMP Trap Parameter Settings in the CTP Menu**

Field	Function	Your Action
Missing Pkts generate snmp trap	Number of missing packets that must be within one second of generating a trap before the trap is actually generated.	Enter a number from 0 through 255.  A setting of 0 means that no SNMP trap is generated for missing packets.

**Table 79: SNMP Trap Parameter Settings in the CTP Menu *(Continued)***

Field	Function	Your Action
Late Pkts generate snmp trap	Number of late packets that must be within one second of generating a trap before the trap is actually generated. Late packets are packets that arrived too late at the CTP device to be processed out the interface.	Enter a number from 0 through 255.  A setting of 0 means that no SNMP trap is generated for late packets.

# 4

PART

## Troubleshooting

---

Knowledge Base | 269

---

## CHAPTER 14

# Knowledge Base