

Junos Fusion Enterprise User Guide

Published
2023-03-28

Juniper Networks, Inc.
1133 Innovation Way
Sunnyvale, California 94089
USA
408-745-2000
www.juniper.net

Juniper Networks, the Juniper Networks logo, Juniper, and Junos are registered trademarks of Juniper Networks, Inc. in the United States and other countries. All other trademarks, service marks, registered marks, or registered service marks are the property of their respective owners.

Juniper Networks assumes no responsibility for any inaccuracies in this document. Juniper Networks reserves the right to change, modify, transfer, or otherwise revise this publication without notice.

Junos Fusion Enterprise User Guide

Copyright © 2023 Juniper Networks, Inc. All rights reserved.

The information in this document is current as of the date on the title page.

YEAR 2000 NOTICE

Juniper Networks hardware and software products are Year 2000 compliant. Junos OS has no known time-related limitations through the year 2038. However, the NTP application is known to have some difficulty in the year 2036.

END USER LICENSE AGREEMENT

The Juniper Networks product that is the subject of this technical documentation consists of (or is intended for use with) Juniper Networks software. Use of such software is subject to the terms and conditions of the End User License Agreement ("EULA") posted at <https://support.juniper.net/support/eula/>. By downloading, installing or using such software, you agree to the terms and conditions of that EULA.

Table of Contents

About This Guide | xi

1

Junos Fusion Enterprise

Junos Fusion Enterprise Overview | 3

Junos Fusion Enterprise Overview | 3

Understanding Junos Fusion Enterprise Components | 6

Understanding Satellite Device Clustering in a Junos Fusion | 15

Understanding Junos Fusion Ports | 20

Understanding Software in a Junos Fusion Enterprise | 25

Understanding Configuration Synchronization in a Junos Fusion | 28

Understanding Junos Fusion Enterprise Software and Hardware Requirements | 29

Understanding ICCP in a Junos Fusion using Dual Aggregation Devices | 40

Understanding the Flow of Data Packets in a Junos Fusion Topology | 42

Understanding Satellite Policies in a Junos Fusion | 46

Understanding Multicast Forwarding on a Junos Fusion Enterprise | 47

Junos Fusion Enterprise Configuration | 50

Configuring or Expanding a Junos Fusion Enterprise | 50

Preparing the Aggregation Devices | 51

Preparing a Switch Running Junos OS to Become a Satellite Device | 52

Configuring the FPC Slot IDs, Cascade Ports, and Satellite Device Clusters on the Junos Fusion | 54

Configuring the FPC Slot ID and Cascade Ports for a Standalone Satellite Device | 55

Configuring the FPC Slot ID, Cascade Ports, and Satellite Device Clusters for Satellite Devices in a Satellite Device Cluster | 58

Managing Software Upgrade Groups on the Aggregation Device | 61

Configuring the Dual Aggregation Device Topology (Dual Aggregation Device Topologies Only) | 64

Installing Satellite Software and Adding Satellite Devices to the Junos Fusion | 69

Junos Fusion Enterprise Installation Checklist | 72

- Adding a Switch Running Satellite Software to a Junos Fusion Enterprise | 86
- Enabling Configuration Synchronization Between Aggregation Devices in a Junos Fusion | 89
- Configuring Uplink Port Policies on a Junos Fusion | 94
 - Configuring an Uplink Port Policy for a Standalone Satellite Device | 94
 - Configuring an Uplink Port Policy for a Satellite Device Cluster | 95
- Configuring Satellite Device Alarm Handling Using an Environment Monitoring Satellite Policy in a Junos Fusion | 96

Junos Fusion Enterprise Configuration Statements | 100

- aging-timer (Junos Fusion) | 101
- alarm (Satellite Policies) | 102
- alias (Junos Fusion) | 104
- alias (Junos Fusion Satellite Device Clustering) | 106
- auto-satellite-conversion (Junos Fusion) | 107
- bgp-peer | 109
- cascade-port | 110
- cascade-ports | 112
- cascade-ports (Junos Fusion Satellite Device Cluster) | 114
- cluster (Junos Fusion) | 115
- cluster-id (Junos Fusion Satellite Device Cluster) | 117
- description (Junos Fusion) | 118
- description (Junos Fusion Satellite Device Cluster) | 120
- environment-monitoring-policy (satellite-management) | 121
- environment-monitoring-policy (satellite-policies) | 123
- fpc (Junos Fusion) | 125
- fpc (Junos Fusion Satellite Device Cluster) | 127
- linkdown (satellite-policies alarm) | 128
- mclag | 130

member-id (Junos Fusion Satellite Device Cluster) | 131

no-auto-iccp-provisioning (Junos Fusion Redundancy Group) | 133

redundancy-group-id (Junos Fusion) | 134

satellite (Junos Fusion Automatic Satellite Conversion) | 136

satellite (Junos Fusion Satellite Device Homing) | 138

satellite (Junos Fusion Satellite Software Upgrade Groups) | 139

satellite-management (Junos Fusion) | 141

serial-number (Junos Fusion) | 144

single-home (Junos Fusion) | 146

system-id (Junos Fusion) | 147

system-id (Junos Fusion Satellite Device Cluster) | 149

upgrade-groups (Junos Fusion) | 151

Junos Fusion Enterprise Administration | 154

Managing Satellite Software Upgrade Groups in a Junos Fusion | 154

- Creating a Satellite Software Upgrade Group | 155
- Adding Satellite Devices to a Satellite Software Upgrade Group | 155
- Removing a Satellite Device from a Satellite Software Upgrade Group | 156
- Modifying the Satellite Software Used by a Satellite Software Upgrade Group | 157
- Deleting Associated Satellite Software from a Satellite Software Upgrade Group | 158
- Deleting Satellite Software on the Aggregation Device | 159

Upgrading Junos OS and Satellite Software in an Operational Junos Fusion Enterprise with Dual Aggregation Devices | 159

Verifying Connectivity, Device States, Satellite Software Versions, and Operations in a Junos Fusion | 161

- Verifying a Junos Fusion Configuration | 161
- Verifying Basic Junos Fusion Connectivity | 162
- Verifying the Satellite Device Hardware Model | 164
- Verifying Cascade Port and Uplink Port State | 165
- Verifying That a Cascade Port Recognizes a Satellite Device | 169
- Verifying Extended Port Operation | 172

Verifying the Satellite Software Version | 175

Verifying the Devices and Software Used in a Satellite Software Upgrade Group | 176

Converting a Satellite Device in a Junos Fusion to a Standalone Device | 178

Download Junos OS Software | 178

Disable the Automatic Conversion Configuration | 179

Install Junos OS Software on the Satellite Device | 180

Installing Junos OS Software on a Standalone Device Running Satellite Software | 182

Junos Fusion Enterprise Operational Commands | 185

request chassis device-mode satellite | 186

request chassis satellite beacon | 188

request chassis satellite disable | 190

request chassis satellite enable | 192

request chassis satellite file-copy | 193

request chassis satellite install | 195

request chassis satellite interface | 198

request chassis satellite login | 199

request chassis satellite reboot | 201

request chassis satellite restart | 203

request chassis satellite shell-command | 204

request system software add (Junos OS) | 205

request system software delete (Junos OS) | 223

request system software rollback (Junos OS) | 228

request system storage cleanup (Junos OS) | 234

show chassis alarms | 249

show chassis environment | 278

show chassis environment fpc | 399

show chassis environment pem | 479

show chassis environment routing-engine | 501

show chassis fan | 511

show chassis firmware | 529

show chassis hardware | 549

show chassis led satellite | 577

show chassis routing-engine | 583

show chassis satellite | 594

show chassis satellite extended-port | 610

show chassis satellite interface | 615

show chassis satellite neighbor | 623

show chassis satellite redundancy-group | 630

show chassis satellite redundancy-group devices | 634

show chassis satellite software | 637

show chassis satellite statistics | 641

show chassis satellite unprovision | 648

show chassis satellite upgrade-group | 655

show chassis satellite-cluster | 660

show chassis satellite-cluster route | 668

show chassis satellite-cluster statistics | 671

show chassis temperature-thresholds | 676

show interfaces extensive satellite-device | 705

show interfaces satellite-device | 731

show interfaces statistics | 738

show interfaces terse satellite-device | 757

show system core-dumps | 761

Enabling Layer 3 Support in a Junos Fusion Enterprise | 781

Understanding Integrated Routing and Bridging (IRB) Interfaces in a Junos Fusion Enterprise | 781

802.1X in a Junos Fusion Enterprise | 782

Understanding 802.1X on a Junos Fusion Enterprise | 782

Junos Fusion Enterprise Half-Duplex Links on Satellite Devices | 784

Understanding Half-Duplex Links on Satellite Devices in a Junos Fusion Enterprise | 784

link-mode | 785

Junos Fusion Enterprise Network Monitoring and Analyzers | 788

Understanding sFlow Technology on a Junos Fusion Enterprise | 788

Understanding Port Mirroring Analyzers on a Junos Fusion Enterprise | 790

Junos Fusion Enterprise Private VLANs | 793

Understanding Private VLANs on a Junos Fusion Enterprise | 793

Power over Ethernet, LLDP, and LLDP-MED on Junos Fusion Enterprise | 796

Understanding Power over Ethernet in a Junos Fusion | 796

Understanding LLDP and LLDP-MED on a Junos Fusion | 799

Configuring Power over Ethernet in a Junos Fusion | 801

PoE Configurable Options | 801

Enabling PoE | 803

Disabling PoE | 803

Setting the Power Management Mode | 804

Setting the Maximum Power That Can Be Delivered from a PoE Interface | 805

Setting the Guard Band | 805

Setting the PoE Interface Priority | 806

Verifying PoE Configuration and Status for a Junos Fusion (CLI Procedure) | 806

PoE Power Budgets, Consumption, and Mode on Satellite Devices | 807

PoE Interface Configuration and Status | 808

Configuration Statements for Power over Ethernet and Power Supply Management on Junos Fusion Enterprise | 811

disable (Power over Ethernet) | 811

guard-band | 813

interface (Power over Ethernet) | 815

management | 816

maximum-power (Interface) | 819

n-plus-n (satellite-management) | 821

poe | 823

priority (Power over Ethernet) | 825

psu (satellite-management) | 827

redundancy (satellite-management) | 828

Operational Commands for Power over Ethernet and Power Supply Management on Junos Fusion Enterprise | 831

show chassis satellite power-budget-statistics | 831

show poe controller | 835

show poe interface | 839

Link Aggregation and LACP on Junos Fusion Enterprise | 848

Configuring Link Aggregation on Satellite Devices in a Junos Fusion Enterprise | 848

Configuring an Aggregated Ethernet Interface | 850

Configuring Aggregated Ethernet LACP | 851

Configuring the LACP Interval | 853

Configuring LACP Link Protection | 854

Configuring LACP System Priority | 855

Configuring LACP System Identifier | 855

Configuring LACP administrative Key | 856

Configuring LACP Port Priority | 856

Tracing LACP Operations | 857

LACP Limitations | 857

Example: Configuring Aggregated Ethernet LACP | 857

SNMP MIB Support on Junos Fusion Enterprise | 860

Chassis MIB Support (Junos Fusion) | 860

Media Access Control Security (MACsec) on Junos Fusion Enterprise | 865

Understanding Media Access Control Security on a Junos Fusion Enterprise | 865

Class of Service on Junos Fusion Enterprise | 867

Understanding CoS in Junos Fusion Enterprise | 867

Configuring CoS in Junos Fusion Enterprise | 872

Configuring Behavior Aggregate Classifiers on Satellite Device Extended Ports | 872

Configuring Rewrite Rules on Satellite Device Extended Ports | 874

Changing the Default Scheduling Policy on an Aggregated Device Cascade Port | 875

Extending a Junos Fusion Enterprise Using EVPN-MPLS | 880

Understanding EVPN-MPLS Interworking with Junos Fusion Enterprise and MC-LAG | 880

Example: EVPN-MPLS Interworking With Junos Fusion Enterprise | 886

Requirements | 887

Overview and Topology | 887

Aggregation Device (PE1 and PE2) Configuration | 890

PE3 Configuration | 902

Storm Control on a Junos Fusion Enterprise | 907

Understanding Storm Control on a Junos Fusion Enterprise | 907

DHCP Snooping and Port Security on a Junos Fusion Enterprise | 909

Understanding Port Security Features on a Junos Fusion Enterprise | 909

MAC Limiting and Persistent MAC Learning on a Junos Fusion Enterprise | 911

Understanding MAC Address Limiting and Persistent MAC Learning on a Junos Fusion Enterprise | 911

About This Guide

Junos Fusion Enterprise enables enterprise switching networks to combine numerous switches into a single, port-dense system managed from a single point known as the aggregation device. Junos Fusion Enterprise simplifies network administration because the system is viewed as a single device by the larger network. Use the topics on this page to understand Junos Fusion Enterprise, configure the aggregation device, and manage satellite devices.

1

PART

Junos Fusion Enterprise

[Junos Fusion Enterprise Overview | 3](#)

[Junos Fusion Enterprise Configuration | 50](#)

[Junos Fusion Enterprise Configuration Statements | 100](#)

[Junos Fusion Enterprise Administration | 154](#)

[Junos Fusion Enterprise Operational Commands | 185](#)

[Enabling Layer 3 Support in a Junos Fusion Enterprise | 781](#)

[802.1X in a Junos Fusion Enterprise | 782](#)

[Junos Fusion Enterprise Half-Duplex Links on Satellite Devices | 784](#)

[Junos Fusion Enterprise Network Monitoring and Analyzers | 788](#)

[Junos Fusion Enterprise Private VLANs | 793](#)

[Power over Ethernet, LLDP, and LLDP-MED on Junos Fusion Enterprise | 796](#)

[Configuration Statements for Power over Ethernet and Power Supply Management on Junos Fusion Enterprise | 811](#)

[Operational Commands for Power over Ethernet and Power Supply Management on Junos Fusion Enterprise | 831](#)

[Link Aggregation and LACP on Junos Fusion Enterprise | 848](#)

[SNMP MIB Support on Junos Fusion Enterprise | 860](#)

[Media Access Control Security \(MACsec\) on Junos Fusion Enterprise | 865](#)

[Class of Service on Junos Fusion Enterprise | 867](#)

[Extending a Junos Fusion Enterprise Using EVPN-MPLS | 880](#)

Storm Control on a Junos Fusion Enterprise | 907

DHCP Snooping and Port Security on a Junos Fusion Enterprise | 909

MAC Limiting and Persistent MAC Learning on a Junos Fusion Enterprise | 911

Junos Fusion Enterprise Overview

IN THIS CHAPTER

- Junos Fusion Enterprise Overview | 3
- Understanding Junos Fusion Enterprise Components | 6
- Understanding Satellite Device Clustering in a Junos Fusion | 15
- Understanding Junos Fusion Ports | 20
- Understanding Software in a Junos Fusion Enterprise | 25
- Understanding Configuration Synchronization in a Junos Fusion | 28
- Understanding Junos Fusion Enterprise Software and Hardware Requirements | 29
- Understanding ICCP in a Junos Fusion using Dual Aggregation Devices | 40
- Understanding the Flow of Data Packets in a Junos Fusion Topology | 42
- Understanding Satellite Policies in a Junos Fusion | 46
- Understanding Multicast Forwarding on a Junos Fusion Enterprise | 47

Junos Fusion Enterprise Overview

Junos Fusion provides a method of significantly expanding the number of available network interfaces on a device—called an *aggregation device*—by allowing the aggregation device to add interfaces through interconnections with *satellite devices*. The entire system—the interconnected aggregation device and satellite devices—is called a *Junos Fusion*. A Junos Fusion simplifies network topologies and administration because it appears to the larger network as a single, port-dense device that is managed using one IP address.

Junos Fusion Enterprise brings the Junos Fusion technology to enterprise switching networks. In a Junos Fusion Enterprise, EX9200 switches act as aggregation devices while EX2300, EX3400, EX4300 or QFX5100 switches act as satellite devices.

Junos Fusion Enterprise provides the following benefits:

- Hides the complexity of managing a large campus network with a single point of management for up to 6,000 ports or 128 switches.

- Reduces operational costs with plug-and-play provisioning of access devices.
- Easy to scale by adding satellite devices for additional ports.

In a Junos Fusion Enterprise, each satellite device has at least one connection to the aggregation device. The aggregation device acts as the single point of management for all devices in the Junos Fusion Enterprise. The satellite devices provide network interfaces that send and receive network traffic.

[Figure 1 on page 4](#) provides an illustration of a basic Junos Fusion Enterprise topology.

Figure 1: Basic Junos Fusion Enterprise Topology

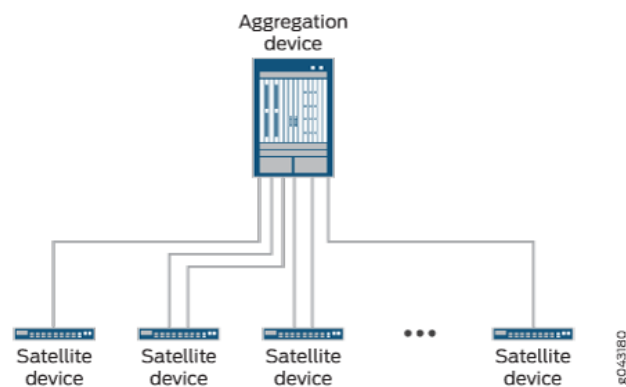

Junos Fusion Enterprise supports up to two aggregation devices that can be multi-homed to each satellite device, as well as satellite device clustering, which allows multiple satellite devices to be clustered into a group and cabled into the Junos Fusion as a group instead of as individual satellite devices. A Junos Fusion Enterprise using two aggregation devices uses the ICCP protocol from MC-LAG to connect and maintain the Junos Fusion topology.

[Figure 2 on page 5](#) illustrates an example of a more complex Junos Fusion Enterprise topology. This dual-aggregation topology includes both standalone and clustered satellite devices. The aggregation devices are multi-homed to each standalone satellite device and to each satellite device cluster.

Figure 2: Junos Fusion Topology with Dual Aggregation Devices and Satellite Device Clusters

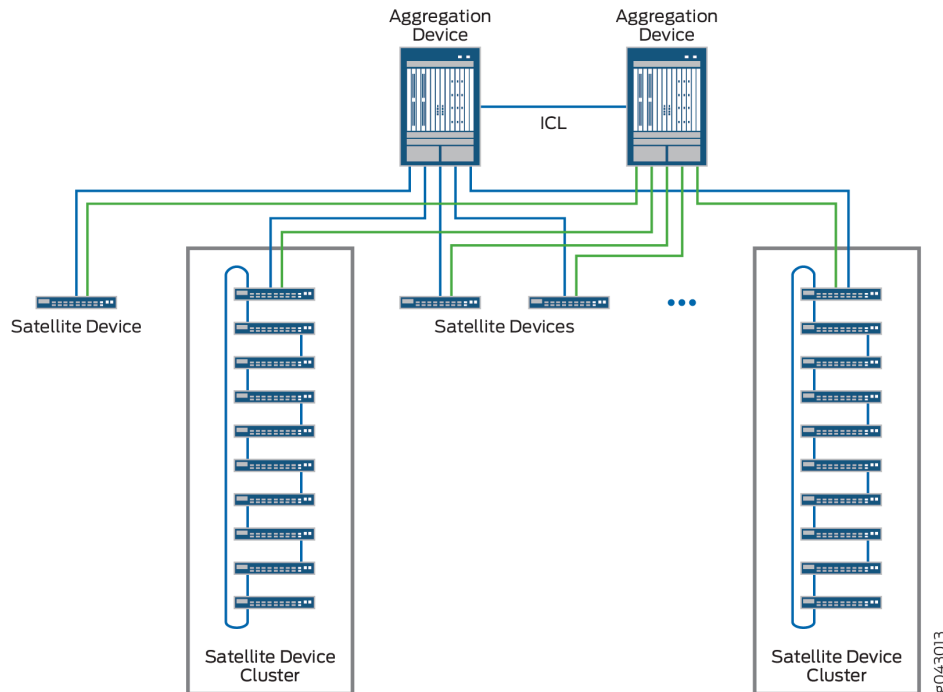

An EX9200 switch acting as an aggregation device in a Junos Fusion Enterprise is responsible for almost all management tasks, including interface configuration for every satellite device interface in the topology. The aggregation device runs Junos OS software for the entire Junos Fusion Enterprise, and the network-facing interfaces on the satellite devices—called *extended ports*—are configured from the aggregation device and support features that are supported by the version of Junos OS running on the aggregation device.

The satellite devices and the aggregation device maintain the control plane for the Junos Fusion Enterprise using multiple internal satellite management protocols. Network traffic can be forwarded between satellite devices through the aggregation device. Junos Fusion Enterprise supports the IEEE 802.1BR standard.

Junos Fusion Enterprise provides the following benefits:

- Simplified network topology—You can combine multiple devices into a topology that appears to the larger network as a single device, and then manage the device from a single IP address.
- Port density—You can configure a large number of network-facing interfaces into a topology that operates as a single network device.
- Manageability—You can manage a Junos Fusion that supports a large number of network-facing interfaces from a single point. The single point of management, the aggregation device, runs Junos OS software for the entire Junos Fusion.

- Flexibility—You can easily expand the size of your Junos Fusion by adding satellite devices to the Junos Fusion as your networking needs grow.
- Investment protection—In environments that need to expand because the capabilities of the existing hardware are maximized, a Junos Fusion can be a logical upgrade option because it enables the network to evolve with minimal disruption to the existing network and without having to remove the existing, previously purchased devices from the network.

RELATED DOCUMENTATION

[Network Configuration Example: Enabling Junos Fusion Enterprise on an Enterprise Campus Network](#)

[Understanding Junos Fusion Enterprise Components | 6](#)

[Understanding Junos Fusion Ports | 20](#)

[Understanding the Flow of Data Packets in a Junos Fusion Topology | 42](#)

[Configuring or Expanding a Junos Fusion Enterprise | 50](#)

Understanding Junos Fusion Enterprise Components

IN THIS SECTION

- [Junos Fusion Topology | 7](#)
- [Aggregation Devices | 8](#)
- [Satellite Devices | 9](#)
- [Cascade Ports | 10](#)
- [Uplink Ports | 11](#)
- [Extended Ports | 12](#)
- [Clustering Ports | 12](#)
- [Understanding FPC Identifiers and Assignment in a Junos Fusion | 13](#)
- [Understanding Software in a Junos Fusion Enterprise | 14](#)
- [Understanding Interface Naming in a Junos Fusion | 14](#)
- [Understanding Feature Configuration in a Junos Fusion Enterprise | 15](#)

This topic describes the components of a Junos Fusion Enterprise. It covers:

Junos Fusion Topology

A basic Junos Fusion topology is composed of an aggregation device and multiple satellite devices. Each satellite device has at least one connection to the aggregation device. The satellite devices provide interfaces that send and receive network traffic. Network traffic can be forwarded over the aggregation device within the Junos Fusion.

The satellite devices and the aggregation device maintain the control plane for the Junos Fusion using multiple internal satellite management protocols. Junos Fusion supports the IEEE 802.1BR standard.

The aggregation device acts as the management points for all devices in the Junos Fusion. All Junos Fusion management responsibilities, including interface configuration for every satellite device interface in the Junos Fusion, are handled by the aggregation device. The aggregation device runs Junos OS software for the entire Junos Fusion, and the interfaces on the satellite devices are configured from the aggregation device and mostly support features that are supported by the version of Junos OS running on the aggregation device.

See [Figure 3 on page 7](#) for an illustration of a basic Junos Fusion topology.

Figure 3: Basic Junos Fusion Topology

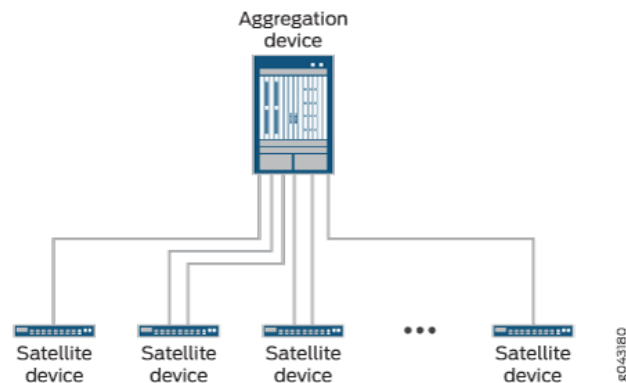

Junos Fusion Enterprise supports multihomed dual aggregation device topologies and satellite device clusters. A multihomed topology with two aggregation devices provides load balancing and redundancy to the Junos Fusion Enterprise topology. A satellite device cluster allows you to group multiple satellite devices into a single group, and connect the group to the Junos Fusion as a group instead of as single standalone devices. Dual aggregation device topologies and satellite device clustering are discussed in more detail in "[Dual Aggregation Device Topologies](#)" on page 9 and "[Satellite Device Clustering](#)" on page 10.

[Figure 4 on page 8](#) shows a complex Junos Fusion Enterprise topology using dual aggregation devices and satellite device clusters.

Figure 4: Junos Fusion Topology with Dual Aggregation Devices and Satellite Device Clusters

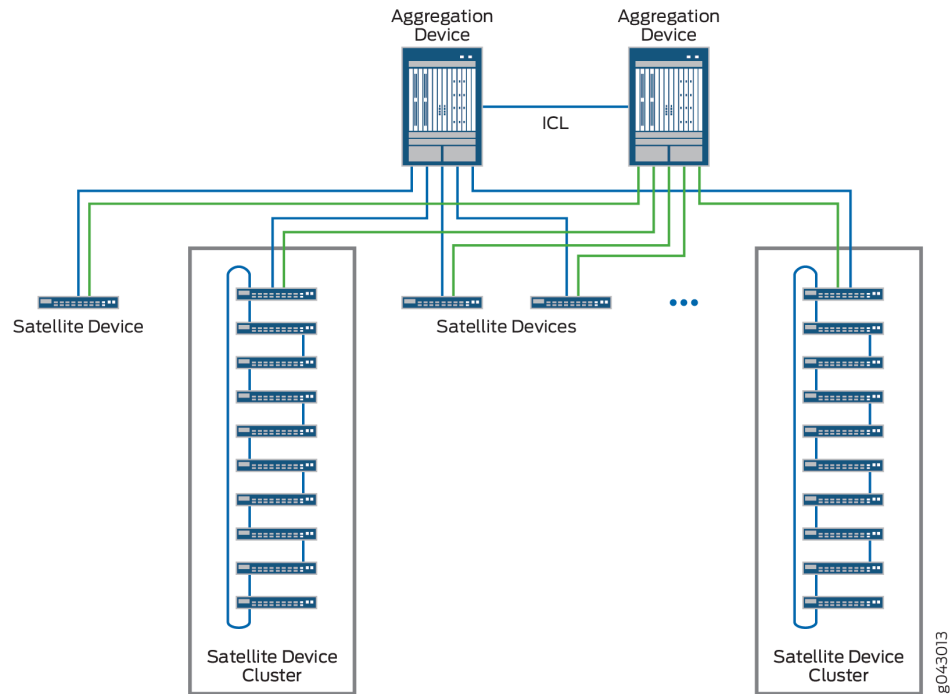

Aggregation Devices

This section discusses aggregation devices and contains the following sections:

Aggregation Devices Overview

An aggregation device:

- Is an EX9200 switch in a Junos Fusion Enterprise.
- Has at least one connection to each satellite device or satellite device cluster.
- Runs Junos OS software.
- Manages the entire Junos Fusion. All Junos Fusion configuration management is handled on the aggregation device or devices, including interface configuration of the satellite device interfaces.

The hardware specifications for aggregation devices in a Junos Fusion Enterprise are discussed in greater detail in [Understanding Junos Fusion Enterprise Software and Hardware Requirements](#).

Dual Aggregation Device Topologies

Junos Fusion Enterprise supports dual aggregation device topologies. The advantages of a dual aggregation device topology include:

- Load balancing. Traffic traversing the Junos Fusion Enterprise can be load balanced across both aggregation devices.
- Redundancy. The Junos Fusion Enterprise can pass traffic even in the unexpected event of an aggregation device failure.

A Junos Fusion Enterprise supports multiple aggregation devices using Multichassis Link Aggregation (MC-LAG) groups and the Inter-Chassis Control Protocol (ICCP).

A Junos Fusion Enterprise with dual aggregation devices is configured as an MC-LAG with one redundancy group. The redundancy group includes two peering chassis IDs—the aggregation devices—and all satellite devices in the Junos Fusion Enterprise. The aggregation devices are connected using an interchassis link (ICL) in the MC-LAG topology.

ICCP runs inside the Junos Fusion on all dual aggregation topologies. ICCP parameters are automatically configured in a Junos Fusion Enterprise by the automatic ICCP provisioning feature, which simplifies the ICCP configuration procedure. ICCP configuration can be customized, however.

[Figure 4 on page 8](#) provides an illustration of a dual aggregation device topology.

Satellite Devices

Satellite Devices Overview

A satellite device:

- Is an EX2300, EX3400, EX4300, EX4600 or QFX5100 switch in a Junos Fusion Enterprise.
- Runs a version of satellite software after being converted into a satellite device.
- Has either a direct connection to an aggregation device, or is part of a satellite device cluster that is cabled to an aggregation device.
- Provides network interfaces to send and receive traffic for the Junos Fusion.
- Is managed and configured by the aggregation device.

The hardware specifications for satellite devices in a Junos Fusion Enterprise are discussed in greater detail in [Understanding Junos Fusion Enterprise Software and Hardware Requirements](#).

Satellite Device Clustering

Satellite device clustering allows you to connect up to ten satellite devices into a single cluster, and connect the satellite device cluster to the aggregation device as a single group instead of as individual satellite devices.

Satellite device clustering is particularly useful in scenarios where optical cabling options between buildings are limited and in scenarios where you want to preserve optical interfaces for other purposes. If you have, for instance, two buildings that have limited optical interfaces between each other and you want to put an aggregation device in one building and ten satellite devices in the other building, you can group the ten satellite devices into a cluster and connect the cluster to the aggregation device with a single cable.

See "[Understanding Satellite Device Clustering in a Junos Fusion](#)" on page 15 for additional information on satellite device clustering.

Cascade Ports

A *cascade port* is a port on an aggregation device that sends and receives control and network traffic from an attached satellite device or satellite device cluster. All traffic passed between a satellite device or cluster and the aggregation device in a Junos Fusion traverses the cascade port.

The link that connects an aggregation device to a satellite device has an interface on each end of the link. The interface on the aggregation device end of the link is a cascade port. The interface on the satellite device end of the link is an uplink port.

Satellite devices are added to a Junos Fusion by configuring the interface on the aggregation device end of a link into a satellite device.

A cascade port is typically a 10-Gbps interface with an SFP+ transceiver or a 40-Gbps interface with a QSFP+ transceiver, but any interface on the aggregation device that connects to the satellite device can be converted into a cascade port.

NOTE: Direct attach copper (DAC) cable connections cannot be configured as cascade ports.

The location of the cascade ports in a Junos Fusion are illustrated in [Figure 5 on page 11](#).

Figure 5: Cascade Ports

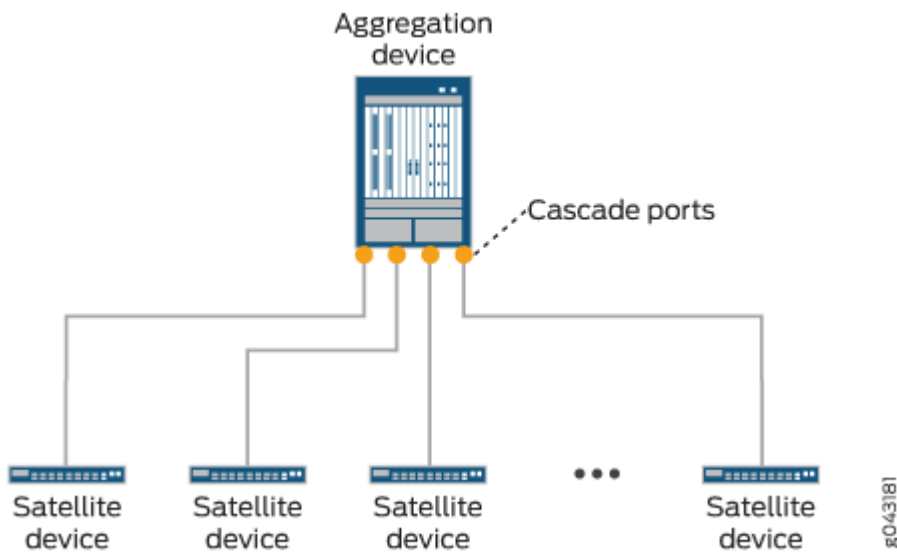

The hardware specifications for cascade ports for a Junos Fusion Enterprise are discussed in greater detail in [Understanding Junos Fusion Enterprise Software and Hardware Requirements](#).

Uplink Ports

An *uplink port* is a physical interface on a satellite device that provides a connection to an aggregation device. All network and control traffic on a satellite device that is transported to an aggregation device is sent or received on the satellite device's uplink port.

The link that connects an aggregation device to a satellite device has an interface on each end of the link. The interface on the aggregation device end of the link is a cascade port. The interface on the satellite device end of the link is an uplink port. Uplink ports are automatically created when a cascade port is configured on the aggregation device end of the link.

Each satellite device model (EX4300, EX2300, EX3400 and QFX5100) has a set of default uplink ports that the device uses to connect to the aggregation device and, in the case of a satellite device cluster, to other satellite devices. The set of uplink (and clustering) ports may be overridden by configuring an uplink port policy for the device. The uplink port policy must include at least one default uplink port. See ["Configuring Uplink Port Policies on a Junos Fusion" on page 94](#) for more information on uplink port policies.

An uplink port is typically a 10-Gbps SFP+ interface or a 40-Gbps QSFP+ interface, but any 1-Gbps interface that connects a satellite device to an aggregation device can become an uplink port if it is included in an uplink port policy.

A single satellite device can have multiple uplink port connections to an aggregation device. The multiple uplink port connections to a single aggregation device provide redundancy and additional bandwidth for satellite device to aggregation device connections.

Satellite devices in a Junos Fusion with dual aggregation devices must have at least one uplink port connection to each aggregation device.

In a satellite device cluster, some cluster member satellite devices do not have uplink port connections to the aggregation device. Satellite devices in a satellite device cluster pass traffic to the aggregation device using another cluster member's uplink port.

Figure 6 on page 12 labels the uplink port location in a Junos Fusion Enterprise.

Figure 6: Junos Fusion Enterprise Ports

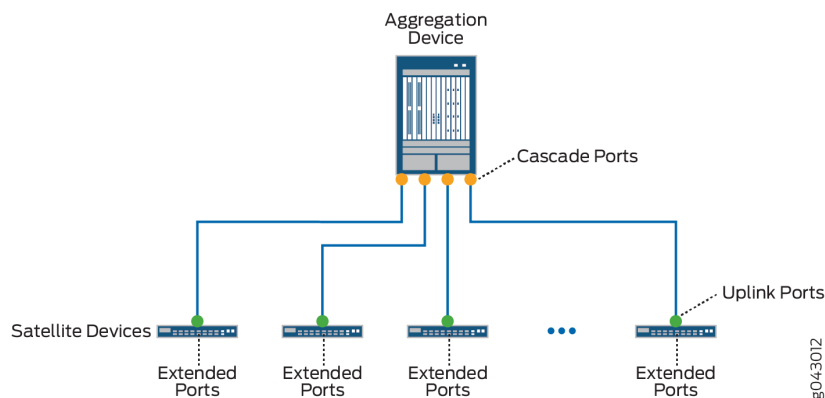

Extended Ports

An *extended port* is a network-facing port on a satellite device that transmits and receives network traffic for the Junos Fusion.

Network traffic received on an extended port is passed, when appropriate, to the aggregation device over the uplink port to cascade port link.

Each network-facing port on a satellite device in a Junos Fusion is also an extended port. A single cascade port is associated with multiple extended ports.

Figure 6 on page 12 labels the extended ports location in a Junos Fusion Enterprise.

Clustering Ports

Clustering ports are interfaces that interconnect satellite devices in the same satellite device cluster.

See ["Understanding Satellite Device Clustering in a Junos Fusion" on page 15](#) for more information on clustering ports.

Understanding FPC Identifiers and Assignment in a Junos Fusion

In a Junos Fusion, each satellite device—including each member satellite device in a satellite device cluster—must have a Flexible PIC Concentrator identifier (FPC ID).

The FPC ID is in the range of 65-254, and is used for Junos Fusion configuration, monitoring, and maintenance. Interface names—which are identified using the *type-fpc / pic / port* format—use the FPC ID as the *fpc* variable when the satellite device is participating in a Junos Fusion. For instance, built-in port 2 on PIC 0 of a satellite device—a Gigabit Ethernet interface on a satellite device that is using 101 as its FPC ID—uses **ge-101/0/2** as its interface name.

A Junos Fusion provides two methods of assigning an FPC identifier:

- Unique ID-based FPC identification
- Connectivity-based FPC identification

In unique ID-based FPC identification, the FPC ID is mapped to the serial number or MAC address of the satellite device. For instance, if a satellite device whose serial number was **ABCDEFGHIJKL** was assigned to FPC ID 110 using unique ID-based FPC identification, the satellite device with the serial number **ABCDEFGHIJKL** will always be associated with FPC ID 110 in the Junos Fusion. If the satellite device with the serial number **ABCDEFGHIJKL** connects to the aggregation device using a different cascade port, the FPC ID for the satellite device remains 110.

In connectivity-based FPC identification, the FPC ID is mapped to the cascade port. For instance, connectivity-based FPC identification can be used to assign FPC ID 120 to the satellite device that connects to the aggregation device using cascade port **xe-0/0/2**. If the existing satellite device that connects to cascade port **xe-0/0/2** is replaced by a new satellite device, the new satellite device connected to the cascade port assumes FPC ID 120.

Unique ID-based FPC identification is configured using the ["serial-number" on page 144](#) or ["system-id" on page 147](#) statement in the [edit [chassis "satellite-management" on page 141](#) ["fpc" on page 125](#) [slot-id](#)] hierarchy.

Connectivity-based FPC identification is configured using the ["cascade-ports" on page 112](#) statement in the [edit [chassis "satellite-management" on page 141](#) ["fpc" on page 125](#) [slot-id](#)] hierarchy.

FPC ID configurations must be identical between aggregation devices in a Junos Fusion Enterprise with two aggregation devices. A satellite device that has two FPC IDs because of mismatched aggregation device configurations goes offline until the configuration issue is fixed.

If a prospective satellite device is connected to a Junos Fusion without having a configured FPC slot ID, the prospective satellite device does not participate in the Junos Fusion until an FPC ID is associated

with it. The **show chassis satellite unprovision** output includes a list of satellite devices that are not participating in a Junos Fusion because of an FPC ID association issue.

Understanding Software in a Junos Fusion Enterprise

In a Junos Fusion, the aggregation device is responsible for all configuration and management within the Junos Fusion and runs Junos OS software.

The satellite devices, meanwhile, run satellite software that has the built-in intelligence to extend features on the Junos OS software onto the satellite device.

The role of Junos OS and satellite software is discussed in greater detail in ["Understanding Software in a Junos Fusion Enterprise" on page 25](#).

You can see software version compatibility information for any Junos Fusion Enterprise using the [Junos Fusion Hardware and Software Compatibility Matrices](#).

The software specifications for a Junos Fusion Enterprise are discussed in greater detail in [Understanding Junos Fusion Enterprise Software and Hardware Requirements](#).

Understanding Interface Naming in a Junos Fusion

Network interfaces in Junos OS are specified as follows:

- *type-fpc / pic / port*

In a Junos Fusion, the interface names on the satellite devices follow this naming convention, where:

- The *type* does not change for the interface when it becomes part of a Junos Fusion. The *type* for a 10-Gbps interface, for instance, remains *xe* regardless of whether the interface is or is not in a Junos Fusion.

You will see internally created *sd* interfaces in a Junos Fusion. The *sd* interfaces map to uplink ports and are used internally by the Junos Fusion to process some types of traffic.

- The *fpc* identifier in a Junos Fusion, which is user-configurable, is the FPC slot identifier. See ["Understanding FPC Identifiers and Assignment in a Junos Fusion" on page 13](#).

For instance, built-in port 2 on PIC 0—a Gigabit Ethernet interface that is acting as an extended port—on the satellite device numbered as FPC slot 101 would be identified as:

ge-101/0/2

Understanding Feature Configuration in a Junos Fusion Enterprise

In a Junos Fusion, the aggregation device is responsible for all configuration and management within the Junos Fusion and runs Junos OS software.

In a Junos Fusion with one aggregation device, all configuration—whether it's a command that enables a feature globally or enables a feature on a specific extended port—is done on the lone aggregation device.

In a Junos Fusion with two aggregation devices, the configuration of any command must match between aggregation devices. If a command is enabled differently on the aggregation devices, the command might be implemented in an unpredictable manner or may not be implemented at all.

A Junos Fusion Enterprise with dual aggregation devices is an MC-LAG topology. MC-LAG topologies support commitment synchronization, a feature that allows users to configure commands on one device within a group and then share that group with other devices. In a Junos Fusion Enterprise with dual aggregation devices, commitment synchronization can be used to ensure identical configuration between aggregation devices by sharing configuration between aggregation devices.

See "[Understanding Configuration Synchronization in a Junos Fusion](#)" on page 28.

RELATED DOCUMENTATION

[Configuring or Expanding a Junos Fusion Enterprise | 50](#)

[Network Configuration Example: Enabling Junos Fusion Enterprise on an Enterprise Campus Network](#)

[Junos Fusion Hardware and Software Compatibility Matrices](#)

Understanding Satellite Device Clustering in a Junos Fusion

IN THIS SECTION

- [Satellite Device Clustering Overview | 16](#)
- [Satellite Device Cluster Topology | 16](#)
- [Satellite Device Cluster Names and Identifiers | 17](#)
- [Satellite Device Cluster Uplink Interfaces | 17](#)
- [Cluster Interfaces | 18](#)
- [Satellite Device Cluster Software Management | 18](#)

- [FPC Identifiers and Extended Port Interfaces in a Satellite Device Cluster | 18](#)
- [Understanding 40-Gbps Interfaces with QSFP+ Transceiver Roles for Satellite Devices in a Satellite Device Cluster | 19](#)

This topic describes satellite device clustering in a Junos Fusion. It covers:

Satellite Device Clustering Overview

Satellite device clustering allows you to connect up to ten satellite devices into a single cluster, then connect the satellite device cluster to the aggregation device as a single group instead of as individual satellite devices.

Satellite device clustering is particularly useful in scenarios where optical cabling options between buildings are limited and in scenarios where you want to preserve optical interfaces for other purposes. If you have, for instance, two buildings that have limited optical interfaces between each other and you want to put an aggregation device in one building and ten satellite devices in the other building, you can group the ten satellite devices into a cluster and connect the cluster to the aggregation device with a single cable.

Satellite Device Cluster Topology

A satellite device cluster must be cabled into a ring topology. No other cabling topologies are supported for a satellite device cluster.

[Figure 7 on page 17](#) shows a picture of a sample satellite device cluster connected to a single aggregation device.

Figure 7: Satellite Device Cluster Topology

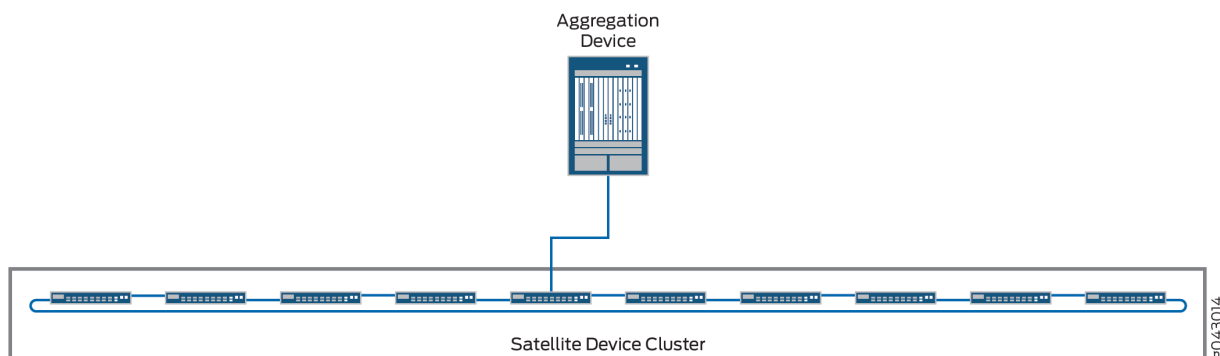

Satellite Device Cluster Names and Identifiers

In a Junos Fusion, each satellite device cluster is named and assigned a number. The number is called the *cluster identifier*, or *cluster ID*.

The cluster name and ID are used by the aggregation device to identify a cluster for configuration, monitoring, and troubleshooting purposes.

The cluster name and ID are set using the `set chassis satellite-management cluster cluster-name cluster-id cluster-id-number` statement.

Satellite Device Cluster Uplink Interfaces

A satellite device cluster must have at least one member with an uplink interface connection to the aggregation device.

In a dual aggregation device topology using satellite device clustering, each satellite device cluster must have at least one uplink interface connection to both aggregation devices. The uplink interfaces to the aggregation devices can be on any member satellite devices in each satellite device cluster.

NOTE: Junos Fusion Provider Edge supports only one aggregation device.

A satellite device cluster supports multiple uplink interfaces. The uplink interfaces can be on any satellite devices that are members of the satellite device cluster. The advantages of configuring multiple uplink interfaces for a satellite device cluster is resiliency—all traffic can be forwarded to another uplink interface if an uplink interface fails—and efficiency—multiple uplink interfaces can reduce the number of hops that traffic takes across a cluster before it is forwarded to an aggregation device.

Cluster Interfaces

Clustering ports are interfaces that interconnect satellite devices in the same satellite device cluster.

Traffic originating from an access device connected to an extended port travels over cluster interfaces to get to an uplink port. Traffic from an aggregation device travels to a satellite device uplink port then over cluster interfaces before it is delivered to an access device connected to an extended port.

Cluster interfaces are typically 10-Gbps SFP+ interfaces. 10-Gbps SFP+ and 40-Gbps QSFP+ interfaces can be used as cluster interfaces. Other interfaces cannot be used as cluster interfaces by default. To use other interfaces as cluster interfaces, you must configure a candidate uplink port policy. See [Configuring Uplink Port Policies on a Junos Fusion](#) for additional information on candidate uplink port policies.

NOTE: DAC cables are not supported on cluster interfaces.

Satellite Device Cluster Software Management

All satellite devices in a satellite device cluster are associated with a single satellite software upgrade group, which is automatically created when a satellite device cluster is configured as part of a Junos Fusion. The satellite software upgrade group is named after the satellite device cluster name, and ensures that all satellite devices in the cluster run the same version of satellite software.

See [Understanding Software in a Junos Fusion Enterprise](#) for additional information on software management for a satellite device cluster.

See [Understanding Junos Fusion Enterprise Software and Hardware Requirements](#) for information on software requirements for satellite devices in a satellite device cluster.

FPC Identifiers and Extended Port Interfaces in a Satellite Device Cluster

Each satellite device in a satellite device cluster has a unique *FPC* identifier (FPC ID), in the same way that a satellite device that is not part of a cluster has a unique FPC ID.

For this reason, all interface naming for satellite device cluster member switches is not impacted by cluster membership. If a switch is assigned FPC ID 103, for instance, the aggregation device views the satellite device as FPC 103 regardless of whether it is or is not part of a satellite device cluster.

The FPC ID is used in the FPC slot name for an extended port interface; for instance, ge-103/0/2. An extended port is any network-facing interface on a satellite device. As with FPC ID naming, extended port interface names are not impacted by satellite device cluster membership status.

NOTE: Satellite devices in a cluster are configured using the unique ID-based FPC identification method of FPC identifier assignment. For more information, see *Understanding FPC Identifiers and Assignment in a Junos Fusion* in [Understanding Junos Fusion Enterprise Components](#).

Understanding 40-Gbps Interfaces with QSFP+ Transceiver Roles for Satellite Devices in a Satellite Device Cluster

40-Gbps QSFP+ interfaces on satellite devices in a satellite device cluster can be used as clustering ports to cable to other satellite devices in the cluster or as uplink ports to cable the satellite device cluster to the aggregation device.

40-Gbps QSFP+ interfaces on EX2300, EX3400, EX4300 and QFX5100 satellite devices are default uplink ports. Please see [Table 1 on page 19](#) for the default uplink ports for satellite devices. When these devices are part of a satellite device cluster, the default uplink ports cannot be configured as extended ports to pass network traffic unless they have a direct connection to the aggregation device or if there is an uplink port policy configured that excludes them from acting as uplink ports.

Table 1: Default Uplink Interfaces for Junos Fusion Enterprise Satellite Devices

Device Type	Default Uplink Interfaces
EX2300 (4 ports on PIC1)	1/0 through 1/3
EX3400 (4 ports each on PIC1 and PIC2)	1/0 through 1/3 and 2/0 through 2/3
EX4300-24P (4 ports each on PIC1 and PIC2)	1/0 through 1/3 and 2/0 through 2/3
EX4300-24T (4 ports each on PIC1 and PIC2)	1/0 through 1/3 and 2/0 through 2/3
EX4300-32F (4 ports on PIC 0, 2 ports on PIC 1 and 8 ports on PIC 2)	0/32 through 0/35 1/0 through 1/1 2/0 through 2/7
EX4300-48P (4 ports each on PIC1 and PIC2)	1/0 through 1/3 and 2/0 through 2/3

Table 1: Default Uplink Interfaces for Junos Fusion Enterprise Satellite Devices (Continued)

Device Type	Default Uplink Interfaces
EX4300-48T (4 ports each on PIC1 and PIC2)	1/0 through 1/3 and 2/0 through 2/3
EX4300-48T-BF (4 ports each on PIC1 and PIC2)	1/0 through 1/3 and 2/0 through 2/3
EX4300-48T-DC (4 ports each on PIC1 and PIC2)	1/0 through 1/3 and 2/0 through 2/3
EX4300-48T-DC-BF (4 ports each on PIC1 and PIC2)	1/0 through 1/3 and 2/0 through 2/3
QFX5100-48S-6Q (6 QSFP+ ports)	0/48 through 0/53
QFX5100-48T-6Q (6 QSFP+ ports)	0/48 through 0/53

RELATED DOCUMENTATION

[Configuring or Expanding a Junos Fusion Enterprise](#)

[Understanding Junos Fusion Enterprise Components](#)

[Configuring Uplink Port Policies on a Junos Fusion](#)

Understanding Junos Fusion Ports**IN THIS SECTION**

- [Understanding Cascade Ports | 22](#)
- [Understanding Uplink Ports | 23](#)
- [Understanding Extended Ports | 24](#)

In a Junos Fusion topology, cascade, uplink, and extended ports are components that play key roles. [Figure 8 on page 22](#) shows a sample Junos Fusion topology, which serves as a point of reference for this discussion of cascade, uplink, and extended ports.

In the Junos Fusion topology shown in [Figure 8 on page 22](#), two aggregation devices and two satellite devices are deployed. The aggregation devices are connected to each other through a multichassis link aggregation group (MC-LAG). Each satellite device has a single-homed connection to its respective aggregation device through one or two links.

On the aggregation devices in each illustration, each link is connected to a cascade port (for example, CP1 on Aggregation device 1), while on the satellite devices, each link is connected to an uplink port (for example, UP1 on Satellite device 1). Hosts 1 through 4 are connected to Satellite device 1 through extended ports EP1 through EP4, and so on.

Figure 8: Cascade, Uplink, and Extended Ports in a Junos Fusion Topology With Two Aggregation Devices and MC-LAG

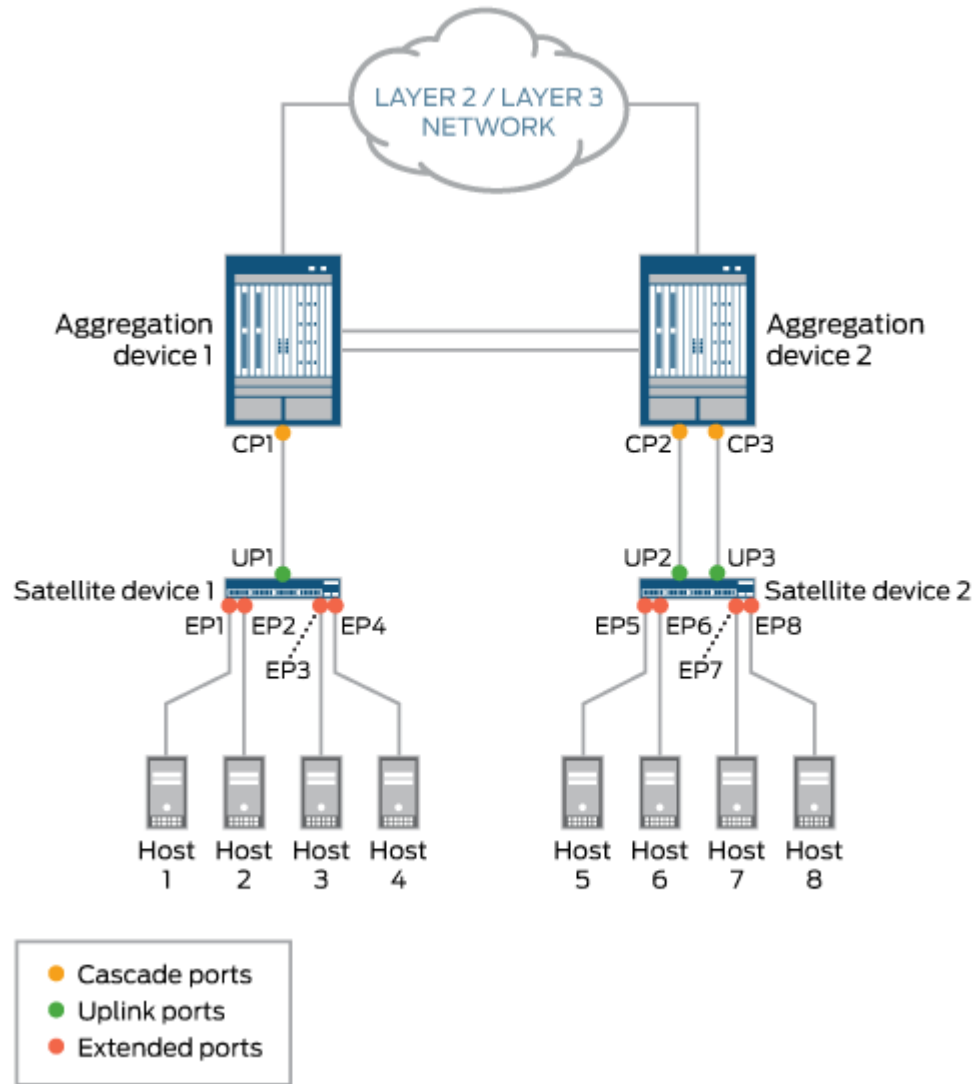

This topic provides the following information:

Understanding Cascade Ports

A *cascade port* is a physical interface on an aggregation device that provides a connection to a satellite device. A cascade port on an aggregation device connects to an uplink port on a satellite device.

On an aggregation device, you can set up one or more cascade port connections with a satellite device. For example, in the Junos Fusion topology shown in [Figure 8 on page 22](#), Aggregation device 1 has one

cascade port connection (CP1) to Satellite device 1, and Aggregation device 2 has two cascade port connections (CP2 and CP3) to Satellite device 2.

When there are multiple cascade port connections to a satellite device, as shown in [Figure 8 on page 22](#), the traffic handled by the ports is automatically load-balanced. For a packet destined for a satellite device, the cascade port over which to forward the packet is chosen based on a per-packet hash that is computed using key fields in the packet. To select the key fields to be used, you can specify the hash-key statement in the [edit forwarding-options] hierarchy or the enhanced-hash-key statement in the [edit forwarding-options], [edit logical-systems *logical-system-name* routing-instances *instance-name* forwarding-options], and [edit routing-instances *instance-name* forwarding-options] hierarchies.

NOTE: The 802.1BR tag is not included in the load-balancing hash computation for cascade ports.

In addition, a cascade port can handle the traffic for all extended ports on a particular satellite device. However, you cannot specify that a particular cascade port handle the traffic for a particular extended port.

After you configure an interface as a cascade port (for example, by issuing `set interfaces xe-0/0/1 cascade-port`), you cannot configure the interface as a Layer 2 interface (for example, by issuing `set interfaces xe-0/0/1 unit 0 family bridge`) or a Layer 3 interface (for example, `set interfaces xe-0/0/1 unit 0 family inet`). If you try to configure a cascade port as a Layer 2 or Layer 3 interface, you receive an error message.

On a cascade port, you can configure class-of-service (CoS) policies.

Understanding Uplink Ports

An *uplink port* is a physical interface on a satellite device that provides a connection to an aggregation device. An uplink port on a satellite device connects to a cascade port on an aggregation device.

After a cascade port is configured on the aggregation device end of a link, a corresponding uplink port is automatically created on the satellite device. From the aggregation device, you can monitor port and queue statistics for uplink ports. However, we do not recommend that you configure Layer 2 or Layer 3 forwarding features on uplink ports.

On a satellite device, you can set up one or more uplink port connections to an aggregation device. For example, in the Junos Fusion topology shown in [Figure 8 on page 22](#), Satellite device 1 has one uplink port (UP1) to Aggregation device 1, and Satellite device 2 has two uplink ports (UP2 and UP3) to Aggregation device 2.

When a satellite device has multiple uplink ports to an aggregation device, the traffic from the extended ports is automatically load-balanced among the uplink ports. For example, in the Junos Fusion topology shown in [Figure 8 on page 22](#), the traffic from extended ports EP5 through EP8 is load balanced

between uplink ports UP2 and UP3 to reach Aggregation device 2. In this situation, each packet is examined, and if an IPv4 or IPv6 header is found, a load-balancing algorithm chooses the uplink port based on the header (source and destination IP addresses, and source and destination TCP/UDP ports). If an IPv4 or IPv6 header is not found, the load-balancing algorithm chooses the uplink port based on the Layer 2 header (destination and source MAC addresses, Ethertype, and outer VLAN ID) of the packet.

Understanding Extended Ports

An *extended port* is a physical interface on a satellite device that provides a connection to servers or endpoints. To an aggregation device, a satellite device appears as an additional Flexible PIC Concentrator (FPC) and the extended ports on the satellite device appear as additional interfaces to be managed by the aggregation device.

On aggregation devices, you can configure extended ports by using the same Junos OS CLI and naming convention used for Junos OS interfaces on standalone routers and switches. The only difference is that when you specify an extended port name, the FPC slot number must be in the range of 100 through 254 in Junos OS Release 14.2 and in the range of 65 through 254 in Junos OS Release 16.1 and later.

For example, for the four extended ports shown on Satellite device 1 in [Figure 8 on page 22](#), the FPC slot number could be 100, the PIC slot number could be 0, the first extended port could be 1, the second extended port could be 2, the third extended port could be 3, and the fourth extended port could be 4. The complete 10-Gigabit Ethernet extended port names could be as follows:

xe-100/0/1

xe-100/0/2

xe-100/0/3

xe-100/0/4

You can configure the following features on extended ports:

- Layer 2 bridging protocols
- Integrated routing and bridging (IRB)
- Firewall filters
- CoS policies

RELATED DOCUMENTATION

[Understanding the Flow of Data Packets in a Junos Fusion Topology](#) | 42

hash-key

enhanced-hash-key

Understanding Software in a Junos Fusion Enterprise

IN THIS SECTION

- [Understanding Junos OS for the Aggregation Device in a Junos Fusion | 25](#)
- [Understanding Satellite Software for the Satellite Devices in a Junos Fusion | 25](#)
- [Understanding Satellite Software Upgrade Groups | 26](#)
- [Understanding Satellite Software Requirements for a Satellite Device Cluster | 27](#)
- [Understanding Satellite Software Requirements in a Dual Aggregation Device Topology | 27](#)
- [Understanding the Platform Specific Satellite Software Image | 28](#)

This topic discusses the role of software in a Junos Fusion Enterprise. It covers:

Understanding Junos OS for the Aggregation Device in a Junos Fusion

An aggregation device in a Junos Fusion always runs Junos OS software and is responsible for almost all management tasks, including configuring all network-facing ports—the *extended ports*—on all satellite devices in the Junos Fusion. The extended ports in a Junos Fusion, therefore, typically support features that are supported by the version of Junos OS running on the aggregation device.

An aggregation device in a Junos Fusion runs the same Junos OS software regardless of whether it is or is not part of a Junos Fusion. Hence, Junos OS software is acquired, installed, and managed on an aggregation device in a Junos Fusion in the same manner that it is acquired, installed, and managed on a standalone device that is not part of a Junos Fusion.

Understanding Satellite Software for the Satellite Devices in a Junos Fusion

The satellite devices in a Junos Fusion run satellite software that has the built-in intelligence to extend features on the Junos OS software onto the satellite device. The satellite software is a Linux-based operating system that allows the satellite devices to communicate with the aggregation device for control plane data while also passing network traffic.

All satellite devices in a Junos Fusion must run satellite software that is compatible with the Junos OS software running on the aggregation device. See [Junos Fusion Hardware and Software Compatibility Matrices](#) for software compatibility requirements and links to the satellite software.

You can run the same version of satellite software on satellite devices that are different hardware platforms. For instance, if your Junos Fusion included EX2300 and EX4300 switches as satellite devices, the EX2300 and EX4300 switches acting as satellite devices could install the satellite software from the same satellite software package.

You can download satellite software from the software center for any satellite device. See the [Junos Fusion Hardware and Software Compatibility Matrices](#), which provides software requirements as well as links to satellite device and Junos OS software. Additionally, you have the option to order some switches with the satellite software preinstalled from the factory.

The satellite software packages are stored on the aggregation device after a satellite software package installation—which is typically managed from the aggregation device—has been executed. The satellite software packages remain in the file system even if the Junos OS on the aggregation device is upgraded. The satellite software on a satellite device can be updated individually or, more commonly, using satellite software upgrade-groups, which are discussed in more detail in this document.

A device cannot simultaneously run Junos OS and the satellite software. If you remove a satellite device from a Junos Fusion, you have to install the Junos OS onto the device before you can use it in your network as a standalone Junos switch.

Satellite software is sometimes referred to as satellite network operating system (SNOS) software in the command-line interface and in other documentation.

The satellite software requirements for a Junos Fusion Enterprise are discussed in [Understanding Junos Fusion Enterprise Software and Hardware Requirements](#).

Understanding Satellite Software Upgrade Groups

A satellite software upgrade group is a group of satellite devices that are designated to upgrade to the same satellite software version. One Junos Fusion can contain multiple software upgrade groups, and multiple software upgrade groups should be configured in most Junos Fusions to avoid network downtimes during satellite software installations.

When a satellite device is added to a Junos Fusion, the aggregation device checks if the satellite device is using an FPC ID that is included in a satellite software upgrade group. If the satellite device is using an FPC ID that is part of a satellite software upgrade group, the device upgrades its satellite software to the version of software associated with the satellite software upgrade group - unless it is already running the defined version.

When the satellite software package associated with an existing satellite software group is changed, the satellite software for all member satellite devices is upgraded using a throttled upgrade. The throttled

upgrade ensures that the aggregation device is not overwhelmed with providing satellite software simultaneously to many satellite devices.

When satellite devices of a satellite device cluster are upgraded, members of the same satellite device cluster download the software to be used and install the software at the same time as other members of the cluster. This ensures that cluster members run the same version of software as each other in case there are incompatibilities between satellite software versions.

The two most common methods of installing satellite software onto a Junos switch—autoconverting a device into a satellite device when it is cabled into an aggregation device and manually converting a device that is cabled into an aggregation device into a satellite device—require the presence of a configured satellite software upgrade group.

Software upgrade groups are configured and managed on the aggregation device.

Understanding Satellite Software Requirements for a Satellite Device Cluster

All satellite devices in a satellite device cluster are associated with a single satellite software upgrade group, which is automatically created when a satellite device cluster is configured as part of a Junos Fusion. The satellite software upgrade group uses the same name as the satellite device cluster name, and ensures that all satellite devices in the cluster run the same version of satellite software.

The automatically created software upgrade group for the satellite device cluster is managed like any other software upgrade group.

Understanding Satellite Software Requirements in a Dual Aggregation Device Topology

In a Junos Fusion with dual aggregation devices, you must ensure that only one version of satellite software is associated with each satellite software upgrade group.

When configuring a Junos Fusion into a dual aggregation topology, do one of the following to ensure satellite software is properly maintained:

- Configure all satellite software upgrade groups on one of the aggregation devices.
- Configure the exact same satellite software upgrade group—a satellite software upgrade group with the same name and same FPC ID associations—on both aggregation devices.

If there is a mismatch between satellite software upgrade group membership or satellite software version for a satellite software upgrade group, satellite software is not upgraded on any satellite devices in the upgrade group until the configuration and version association is addressed.

Understanding the Platform Specific Satellite Software Image

The platform specific satellite software package is required to install satellite software onto an EX2300, EX3400 or EX4300 switch that is not connected to an aggregation device. Use the platform specific satellite software package when you want to manually install satellite software on a switch using the **request chassis device-mode satellite *URL-to-satellite-software*** command before you interconnect that switch into a Junos Fusion Enterprise.

NOTE: Platform specific satellite software is not required for QFX5100 switches.

You can identify the platform specific satellite software by looking for the satellite-ppc prefix in the satellite software image name; for example, satellite-ppc-3.0R1.1-signed.tgz. To find the image that is compatible with your satellite device, please refer to [Junos Fusion Hardware and Software Compatibility Matrices](#).

RELATED DOCUMENTATION

[Junos Fusion Hardware and Software Compatibility Matrices](#)

[Understanding Junos Fusion Enterprise Software and Hardware Requirements | 29](#)

[Configuring or Expanding a Junos Fusion Enterprise | 50](#)

Understanding Configuration Synchronization in a Junos Fusion

All configuration and management for a Junos Fusion are done from the aggregation devices, which run Junos OS software.

In a Junos Fusion with one aggregation device, all configuration—whether it's a configuration statement that enables a feature globally or enables a feature on a specific extended port—is done from the lone aggregation device.

A Junos Fusion with multiple aggregation devices often requires that the configuration of a feature—for example, an extended port, and entities such as routing instances and VLANs that include the extended port—must match on all aggregation devices. If a configuration statement for the feature—in this case, the extended port—is specified differently on one aggregation device, the statement on that particular aggregation device might be implemented in an unpredictable manner or might not be implemented at all.

Junos Fusion supports configuration synchronization, a feature that allows users to specify configuration statements within a group on one aggregation device and then share that group with other aggregation devices.

We strongly recommend using configuration synchronization to configure software features in multiple aggregation device topologies. Configuration synchronization ensures configuration consistency by sharing the exact same configuration between aggregation devices. Configuration synchronization also simplifies administration of a Junos Fusion by allowing users to enter configuration statements once in a configuration group and apply the configuration group to all aggregation devices rather than repeating a configuration procedure manually on each aggregation device.

For more information about configuration synchronization, see ["Enabling Configuration Synchronization Between Aggregation Devices in a Junos Fusion"](#) on page 89, [Understanding MC-LAG Configuration Synchronization](#), and [Synchronizing and Committing MC-LAG Configurations](#).

See [Enabling Junos Fusion Enterprise on an Enterprise Campus Network](#) for a sample Junos Fusion Enterprise topology configured largely using configuration synchronization.

RELATED DOCUMENTATION

| [Enabling Configuration Synchronization Between Aggregation Devices in a Junos Fusion](#) | 89

Understanding Junos Fusion Enterprise Software and Hardware Requirements

IN THIS SECTION

- [Aggregation Device to Satellite Device Software Compatibility](#) | 30
- [Aggregation Devices](#) | 30
- [Satellite Devices](#) | 34

This topic describes the software and hardware requirements for a Junos Fusion Enterprise. For Junos Fusion Provider Edge software and hardware requirements, see [Understanding Junos Fusion Provider Edge Software and Hardware Requirements](#). For Junos Fusion Data Center software and hardware requirements, see [Understanding Junos Fusion Data Center Software and Hardware Requirements](#).

It covers:

Aggregation Device to Satellite Device Software Compatibility

A Junos Fusion Enterprise includes an aggregation device or devices running Junos OS and satellite devices running satellite software. The version of Junos OS running on the aggregation device must be compatible with the satellite software versions running on the satellite device in order for the Junos Fusion Enterprise to function.

See [Junos Fusion Hardware and Software Compatibility Matrices](#) for software compatibility information for any Junos Fusion Enterprise.

NOTE: When you upgrade the satellite software version to a release later than the recommend versions listed in the [Junos Fusion Hardware and Software Compatibility Matrices](#), your Junos Fusion system will only benefit from the satellite software fixes. To acquire the full benefits of a satellite software release, including satellite software fixes and new features, we recommend you upgrade both the aggregation device software and its compatible satellite device software for a complete upgrade.

Aggregation Devices

This section details the hardware and software requirements for an aggregation device in a Junos Fusion Enterprise. It covers:

Aggregation Device Hardware Models

[Table 2 on page 30](#) lists the hardware platforms that are supported as aggregation devices for a Junos Fusion Enterprise. It also lists the supported satellite devices for each Junos OS Release supporting Junos Fusion Enterprise.

Table 2: Supported Aggregation Device Hardware and Supported Satellite Devices by Junos OS Release

Aggregation Device Hardware	Supported Satellite Devices by Junos OS Release
EX9204 Switch	16.1R1 (EX4300)
	17.1R1 (EX2300, EX3400, EX4300)
	17.3R1 (EX2300, EX3400, EX4300, QFX5100)
	18.2R1 (EX2300, EX3400, EX4300, QFX5100, EX4600)

Table 2: Supported Aggregation Device Hardware and Supported Satellite Devices by Junos OS Release (Continued)

Aggregation Device Hardware	Supported Satellite Devices by Junos OS Release
EX9208 Switch	16.1R1 (EX4300) 17.1R1 (EX2300, EX3400, EX4300) 17.3R1 (EX2300, EX3400, EX4300, QFX5100) 18.2R1 (EX2300, EX3400, EX4300, QFX5100, EX4600)
EX9214 Switch	16.1R1 (EX4300) 17.1R1 (EX2300, EX3400, EX4300) 17.3R1 (EX2300, EX3400, EX4300, QFX5100) 18.2R1 (EX2300, EX3400, EX4300, QFX5100, EX4600)
EX9251 Switch	18.1R1 (EX2300, EX3400, EX4300, QFX5100) 18.2R1 (EX2300, EX3400, EX4300, QFX5100, EX4600)
EX9253 Switch	18.2R1 (EX2300, EX3400, EX4300, QFX5100, EX4600)

Maximum Number of Aggregation Devices

A Junos Fusion Enterprise supports one or two aggregation devices.

Cascade Ports

A *cascade port* is a port on an aggregation device that sends and receives control and network traffic from an attached satellite device.

[Table 3 on page 32](#) provides a list of line cards on an EX9200 switch that have interfaces that can be converted into cascade ports, and the initial Junos OS release that introduced cascade port support for interfaces on the line card.

Direct attach copper (DAC) cable connections cannot be configured as cascade ports.

BEST PRACTICE: A cascade port is typically a 10-Gbps interface with an SFP+ transceiver or a 40-Gbps interface with a QSFP+ transceiver, although other interfaces on the aggregation device can be converted into a cascade port.

Table 3: Line Cards on EX9200 Switch Cascade Port Support

Line Card	Switch Model	Initial Junos OS Release
EX9200-6QS (6-port 40-Gigabit Ethernet QSFP+, 24-port 10-Gigabit Ethernet SFP+ line card)	EX9204	16.1R1
	EX9208	16.1R1
	EX9214	16.1R1
EX9200-32XS (32-port SFP+ line card)	EX9204	16.1R1
	EX9208	16.1R1
	EX9214	16.1R1
EX9200-40T (40-port 10/100/1000BASE-T RJ-45 line card)	EX9204	16.1R1
	EX9208	16.1R1
	EX9214	16.1R1
EX9200-MPC (modular line card)	EX9204	17.1R1
The following MICs are supported:	EX9208	17.1R1
• EX9200-10XS-MIC		
• EX9200-20F-MIC		

Table 3: Line Cards on EX9200 Switch Cascade Port Support (*Continued*)

Line Card	Switch Model	Initial Junos OS Release
<ul style="list-style-type: none"> EX9200-40T-MIC 	EX9214	17.1R1
EX9200-40F (40-port 100FX/1000BASE-X SFP line card)	EX9204	17.4R1
	EX9208	17.4R1
	EX9214	17.4R1
EX9200-40F-M (40-port 100FX/1000BASE-X SFP line card with MACsec)	EX9204	17.4R1
	EX9208	17.4R1
	EX9214	17.4R1
EX9200-40XS (40-port 10GbE SFP+ line card with MACsec)	EX9204	17.4R1
	EX9208	17.4R1
	EX9214	17.4R1
EX9200-12QS (12-port 10GbE/40GbE QSFP+ or 4-port 100GbE QSFP28 combo line card)	EX9204	17.4R1
	EX9208	17.4R1
	EX9214	17.4R1
<p>NOTE: All ports can operate at 10-Gbps and 40-Gbps speeds. The ports are configured to operate at 10-Gbps speed by default.</p>		

Table 3: Line Cards on EX9200 Switch Cascade Port Support (Continued)

Line Card	Switch Model	Initial Junos OS Release
EX9253-6Q12C (12-port QSFP28 40GbE/100GbE and 6-port QSFP+ 40GbE line card)	EX9253	18.2R1
EX9253-6Q12C-M (12-port QSFP28 40GbE/100GbE and 6-port QSFP+ 40GbE line card with MACsec)	EX9253	18.2R1

Satellite Devices

This section details the hardware and software requirements for satellite devices in a Junos Fusion Enterprise. It covers:

Satellite Device Hardware Models

[Table 4 on page 34](#) lists the EX2300 switches that are supported as satellite devices for a Junos Fusion Enterprise.

To convert an EX2300 switch from Junos OS to satellite software, the switch must be running Junos OS Release 15.1X53-D55 or later.

To find the required satellite software version, see [Junos Fusion Hardware and Software Compatibility Matrices](#).

Table 4: Supported EX2300 Satellite Device Hardware and Initial Junos OS Release

Hardware	Initial Junos OS Release
EX2300-C-12P	15.1X53-D55
EX2300-C-12T	15.1X53-D55

Table 4: Supported EX2300 Satellite Device Hardware and Initial Junos OS Release (Continued)

Hardware	Initial Junos OS Release
EX2300-24P	15.1X53-D55
EX2300-24T	15.1X53-D55
EX2300-24T-DC	15.1X53-D55
EX2300-48P	15.1X53-D55
EX2300-48T	15.1X53-D55

[Table 5 on page 35](#) lists the EX3400 hardware platforms that are supported as satellite devices for a Junos Fusion Enterprise.

To convert an EX3400 switch from Junos OS to satellite software, the switch must be running Junos OS Release 15.1X53-D55 or later.

To find the required satellite software version, see [Junos Fusion Hardware and Software Compatibility Matrices](#).

Table 5: Supported EX3400 Satellite Device Hardware and Initial Junos OS Release

Hardware	Initial Junos OS Release
EX3400-24P	15.1X53-D55
EX3400-24T	15.1X53-D55
EX3400-24T-DC	15.1X53-D55
EX3400-48P	15.1X53-D55
EX3400-48T	15.1X53-D55

Table 5: Supported EX3400 Satellite Device Hardware and Initial Junos OS Release (Continued)

Hardware	Initial Junos OS Release
EX3400-48T-AFI	15.1X53-D55

[Table 6 on page 36](#) lists the EX4300 hardware platforms that are supported as satellite devices for a Junos Fusion Enterprise.

To convert an EX4300 switch from Junos OS to satellite software, the switch must be running Junos OS Release 14.1X53-D43 or later.

To find the required satellite software version, see [Junos Fusion Hardware and Software Compatibility Matrices](#).

Table 6: Supported EX4300 Satellite Device Hardware and Initial Junos OS Release

Hardware	Initial Junos OS Release
EX4300-24P	14.1X53-D43
EX4300-24T	14.1X53-D43
EX4300-32F	14.1X53-D43
EX4300-48P	14.1X53-D43
EX4300-48T	14.1X53-D43
EX4300-48T-BF	14.1X53-D43
EX4300-48T-DC	14.1X53-D43
EX4300-48T-DC-BF	14.1X53-D43

[Table 7 on page 37](#) lists the QFX5100 hardware platforms that are supported as satellite devices for a Junos Fusion Enterprise.

To convert a QFX5100 switch from Junos OS to satellite software, the switch must be running Junos OS Release 14.1X53-D43 or later.

To find the required satellite software version, see [Junos Fusion Hardware and Software Compatibility Matrices](#).

Table 7: Supported QFX5100 Satellite Device Hardware and Initial Junos OS Release

Hardware	Initial Junos OS Release
QFX5100-48S-6Q	14.1X53-D43
QFX5100-48T-6Q	14.1X53-D43

[Table 8 on page 37](#) lists the EX4600 hardware platforms that are supported as satellite devices for a Junos Fusion Enterprise.

To convert an EX4600 switch from Junos OS to satellite software, the switch must be running Junos OS Release 14.1X53-D47 or later.

To find the required satellite software version, see [Junos Fusion Hardware and Software Compatibility Matrices](#).

NOTE: The EX4600-EM-8F and QFX-EM-4Q expansion modules are not supported in a Junos Fusion Enterprise.

Table 8: Supported EX4600 Satellite Device Hardware and Initial Junos OS Release

Hardware	Initial Junos OS Release
EX4600-40F	14.1X53-D47

Satellite Device Firmware Requirements

[Table 9 on page 38](#) lists the firmware requirements for satellite devices for a Junos Fusion Enterprise.

Table 9: Minimum Satellite Device Firmware Version Requirements

Satellite Device	Minimum U-boot Release	Minimum Loader Version	Minimum PoE Firmware
EX2300	1.3.2	NA	1.6.1.1.9
EX3400	1.3.0	NA	1.6.1.1.9
EX4300	NA	NA	2.6.3.9.2.1
EX4600	NA	NA	NA
QFX5100	NA	NA	NA

Satellite Device Software Requirements for Satellite Device Clustering

A standalone switch must be running the required satellite software before it can be added to a Junos Fusion Enterprise as a member of a satellite device cluster. A standalone switch running any version of satellite software below the minimum required version for that switch is not recognized by the aggregation device and cannot be added to a Junos Fusion Enterprise as a member of a satellite device cluster. To find the required satellite software version, see [Junos Fusion Hardware and Software Compatibility Matrices](#).

If your switch is running a version of satellite or Junos OS software below the required minimum and you want to include the switch in a satellite device cluster, follow one of these procedures:

- if your switch is already cabled into a Junos Fusion and is able to upgrade to a version of satellite software that supports satellite device clustering, upgrade the satellite software on the switch before adding it to the satellite device cluster. See "[Configuring or Expanding a Junos Fusion Enterprise](#)" on page 50.
- If your switch is not cabled into a Junos Fusion, install a version of Junos OS that supports satellite device clustering using the procedure outlined in "[Installing Junos OS Software on a Standalone Device Running Satellite Software](#)" on page 182 before installing the switch into the satellite device cluster.

Once the switch is running a version of Junos OS that supports satellite device clustering, you can install the required satellite software version manually or as part of the satellite software installation that occurs as part of the procedure for adding a satellite device to a Junos Fusion Enterprise.

Satellite Software to Junos OS Conversion Requirements

A satellite device can be removed from a Junos Fusion Enterprise and reinserted into a network as a switch running Junos OS. See [Removing a Satellite Device from a Junos Fusion](#).

A device running satellite software must be converted to a version of Junos OS that supports satellite device conversion. The minimum Junos OS versions that support satellite device conversion are provided in this document.

The following list provides additional information for converting each type of switch from satellite software to Junos OS.

- EX2300 and EX3400 switches:
 - EX2300 and EX3400 switches must be converted to Junos OS Release 15.1X53-D55 or later.
 - EX2300 and EX3400 switches cannot be converted from satellite software to Junos from an aggregation device. To convert the satellite software, remove the satellite device from the Junos Fusion Enterprise and perform the upgrade manually. See [Installing Junos OS Software on a Standalone Device Running Satellite Software](#)
 - The target Junos OS image must be a signed version of Junos OS. The text string *-signed* text must be in the Junos OS image filename when the image is downloaded from the Software Center.
- EX4300 switches:
 - EX4300 switches must be converted to Junos OS Release 14.1X53-D43 or later.
 - The target Junos OS image must be a signed version of Junos OS. The text string *-signed* text must be in the Junos OS image filename when the image is downloaded.
- QFX5100 switches:
 - The QFX5100 switch must be converted to Junos OS Release 14.1X53-D43 or later.
 - The target Junos OS image must be a Preboot eXecution Environment (PXE) version of Junos OS. The PXE version of Junos OS includes *pxe* in the package name when it is downloaded from the Software Center—for example, the PXE image for Junos OS Release 14.1X53-D43 is named *install-media-pxe-qfx-5-14.1X53-D43.3-domestic-signed.tgz*.
 - The target Junos OS image must be a signed version of Junos OS. The text string *-signed* text must be in the Junos OS image filename when the image is downloaded.
- EX4600 switches:
 - The EX4600 switch must be converted to Junos OS Release 14.1X53-D47 or later.

- The target Junos OS image must be a Preboot eXecution Environment (PXE) version of Junos OS. The PXE version of Junos OS includes *pxe* in the package name when it is downloaded from the Software Center—for example, *install-media-pxe-qfx-5-14.1X53-D47.<version>-domestic-signed.tgz*.
- The target Junos OS image must be a signed version of Junos OS. The text string *-signed* text must be in the Junos OS image filename when the image is downloaded.

Power over Ethernet Requirements for a Satellite Device

A satellite device must be running Power over Ethernet (PoE) controller software version as specified in [Table 9 on page 38](#).

To check the PoE controller software version, enter the `show chassis firmware detail` command and view the `PoE firmware` output.

For information on checking and upgrading the PoE controller software, see *Upgrading the PoE Controller Software*.

NOTE: PoE is not supported for QFX5100 satellite devices.

Maximum Number of Satellite Devices or Extended Ports

A Junos Fusion Enterprise supports up to 128 satellite devices or 6,000 extended port access interfaces.

RELATED DOCUMENTATION

[Junos Fusion Hardware and Software Compatibility Matrices](#)

[Configuring or Expanding a Junos Fusion Enterprise | 50](#)

Understanding ICCP in a Junos Fusion using Dual Aggregation Devices

IN THIS SECTION

- [ICCP in a Junos Fusion Overview | 41](#)
- [Automatic ICCP Provisioning | 41](#)

This topic describes the Inter-Chassis Control Protocol (ICCP) in a Junos Fusion. It covers:

ICCP in a Junos Fusion Overview

Inter-Chassis Control Protocol (ICCP) is used in MC-LAG topologies to exchange control information between the devices in the topology. See [Multichassis Link Aggregation Features, Terms, and Best Practices](#) for additional information on ICCP.

A Junos Fusion with two aggregation devices is an MC-LAG topology, and is therefore always running ICCP as the control protocol. A Junos Fusion using a single aggregation device is not an MC-LAG topology and does not run ICCP.

A dedicated ICCP link is highly recommended in a Junos Fusion deployment, but is not required. ICCP traffic is transmitted across the ICL when an ICCP link is not configured. An ICCP link can be one link or an aggregated ethernet interface. In most Junos Fusion deployments, we recommend using a 40-Gbps link or an aggregated ethernet interface as the ICCP link.

Automatic ICCP Provisioning

Junos Fusion supports automatic ICCP provisioning, which automatically configures ICCP in a dual aggregation device setup without any user action. Automatic ICCP provisioning is enabled by default and is often the preferred method of enabling ICCP for a Junos Fusion in greenfield deployments that are not being integrated into an existing network. If you are installing your Junos Fusion in an environment that doesn't have to integrate into an existing campus network, you can usually ignore manual ICCP configuration processes and allow automatic ICCP provisioning to enable ICCP.

Many Junos Fusion installations occur in brownfield deployments and the Junos Fusion has to be integrated into an existing network. Brownfield deployments often have a need to maintain existing ICCP settings, in particular in scenarios where a Junos Fusion is replacing an MC-LAG topology or is supporting a network that includes other MC-LAG topologies. ICCP must be configured manually in these scenarios.

See [Enabling Junos Fusion Enterprise on an Enterprise Campus Network](#) for an example of a Junos Fusion Enterprise deployment that manually configures ICCP.

RELATED DOCUMENTATION

[Multichassis Link Aggregation Features, Terms, and Best Practices](#)

[Configuring or Expanding a Junos Fusion Enterprise](#) | 50

Understanding the Flow of Data Packets in a Junos Fusion Topology

All Ethernet data packets that are exchanged between aggregation devices and satellite devices in a Junos Fusion topology include an E-channel tag (ETAG) header that carries an E-channel identifier (ECID) value. The ECID value, which is assigned by the aggregation device, identifies the source or destination extended port on one of the connected satellite devices.

In a sample Junos Fusion topology, where an aggregation device is connected to two satellite devices, the following Layer 2 unicast data packet flow scenarios can occur:

- Scenario 1—A host on one satellite device sends a packet to another host on the same satellite device. For example, Host 2 sends a unicast packet to Host 4. Both hosts are connected to Satellite device 1. (See [Figure 9 on page 43](#).)
- Scenario 2—A host on one satellite device sends a packet to another host on the other satellite device. For example, Host 2, which is connected to Satellite device 1, sends a unicast packet to Host 7, which is connected to Satellite device 2. (See [Figure 10 on page 44](#).)

Figure 9: Layer 2 Unicast Data Packet Flow Through a Junos Fusion Topology—Scenario 1

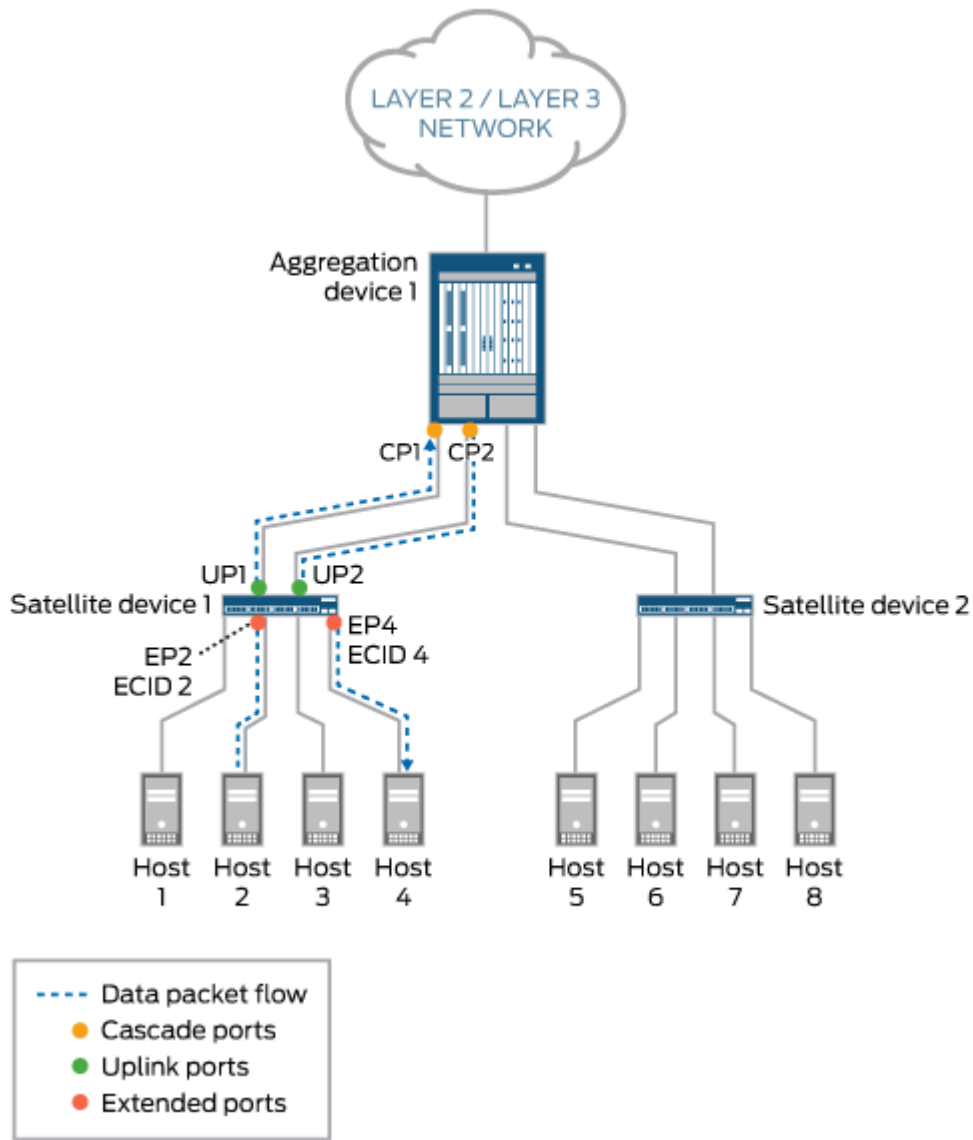
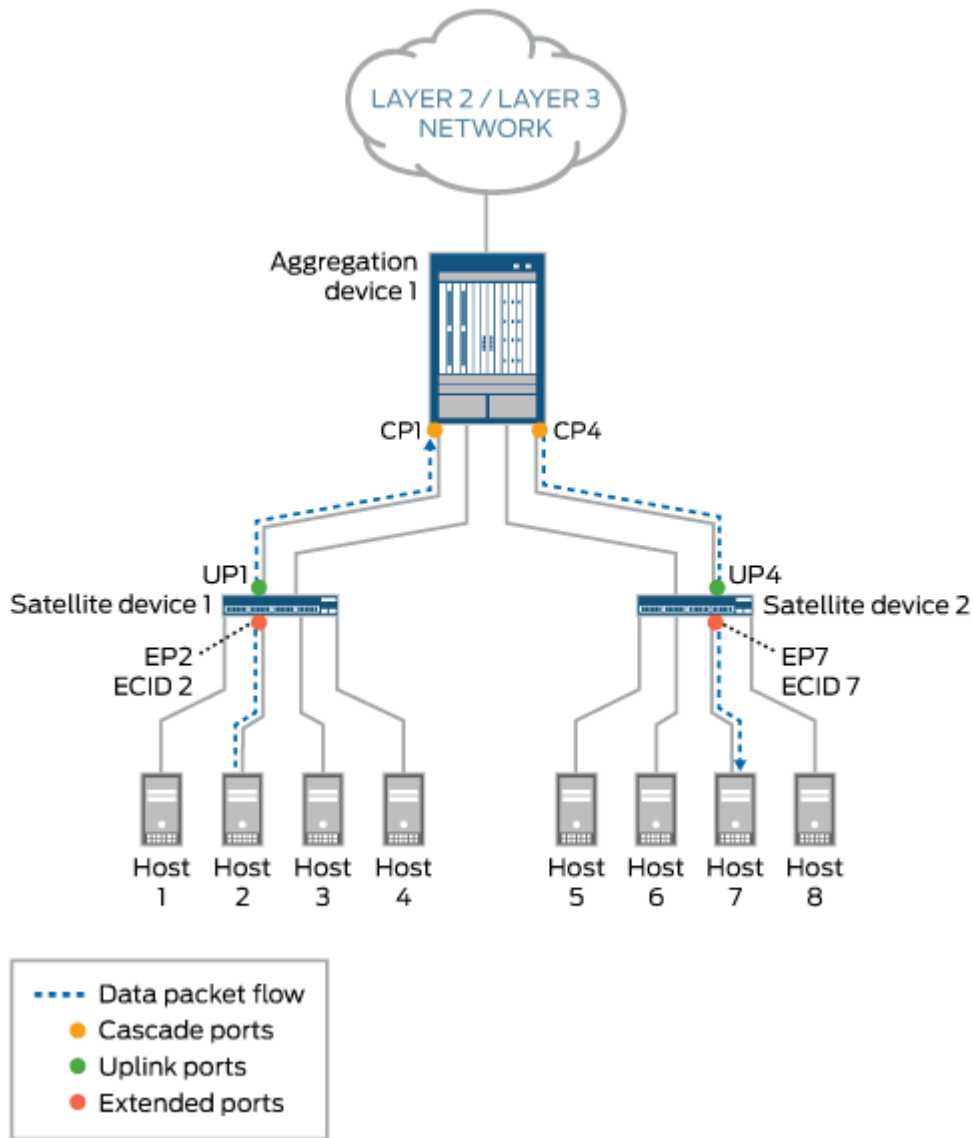

Figure 10: Layer 2 Unicast Data Packet Flow Through a Junos Fusion Topology—Scenario 2



In scenario 1, where Host 2 sends a unicast data packet to Host 4, the following events occur:

NOTE: Only the events that are performed by Junos Fusion components are listed. Events handled by components that are not specific to the Junos Fusion topology are excluded.

1. Extended port EP2 on Satellite device 1 receives the packet from Host 2.

2. Satellite device 1 inserts an ETAG header in the packet. The ETAG header carries the ECID value (ECID 2), which is assigned by Aggregation device 1 to extended port EP2.
3. On Satellite device 1, two uplink ports (UP1 and UP2) are connected to Aggregation device 1. As a result, traffic between the devices can be load-balanced. In this case, uplink port UP1 is chosen to forward the packet to cascade port CP1 on Aggregation device 1.
4. On receiving the packet, Aggregation device 1 extracts the ECID value (ECID 2) from the ETAG header of the packet and learns that the packet is from extended port EP2 on Satellite device 1. Aggregation device 1 then removes the ETAG header from the packet.
5. Aggregation device 1 performs a lookup for Host 4. The result of the lookup is extended port EP4 on Satellite device 1.
6. On Aggregation device 1, two cascade ports (CP1 and CP2) are connected to Satellite device 1. As a result, traffic between the devices can be load-balanced. In this case, cascade port CP2 is chosen to forward the packet to uplink port UP2 on Satellite device 1.
7. The packet is forwarded to cascade port CP2, where a new ETAG header and ECID value (ECID 4), which is assigned by Aggregation device 1 to extended port EP4, is added.
8. The packet is received by uplink port UP2 on Satellite device 1.
9. Satellite device 1 extracts the ECID value (ECID 4) from the ETAG header of the packet, then maps ECID 4 to extended port EP4.
10. Host 4 receives the packet from extended port EP4.

In scenario 2, where Host 2 sends a unicast data packet to Host 7, the events that occur are the same as for scenario 1 except for the following:

- Event 5—Aggregation device 1 performs a lookup for Host 7. The result of the lookup is extended port EP7 on Satellite device 2.
- Event 6—On Aggregation device 1, two cascade ports (CP3 and CP4) are connected to Satellite device 2. As a result, traffic between the devices can be load-balanced. In this case, cascade port CP4 is chosen to forward the packet to uplink port UP4 on Satellite device 2.
- Event 7—The packet is forwarded to cascade port CP4, where a new ETAG header and ECID value (ECID 7), which is assigned by Aggregation device 1 to extended port EP7, is added.
- Event 8—The packet is received by uplink port UP4 on Satellite device 2.
- Event 9—Satellite device 2 extracts the ECID value (ECID 7) from the ETAG header of the packet, and then maps ECID 7 to extended port EP7.
- Event 10—Host 7 receives the packet from extended port EP7.

RELATED DOCUMENTATION

[Understanding Junos Fusion Provider Edge Components](#)

[Understanding Junos Fusion Enterprise Components](#)

Understanding Satellite Policies in a Junos Fusion

IN THIS SECTION

- [Satellite Policies Overview | 46](#)
- [Understanding Environment Monitoring Satellite Policies | 46](#)

Satellite Policies Overview

Satellite policies are used in a Junos Fusion to define how certain features are configured for standalone satellite devices within a Junos Fusion. Satellite policies can be used to configure standalone satellite devices or all satellite devices in a satellite device cluster.

Environment monitoring of the satellite devices, uplink failure detection for satellite device uplink ports, and remapping uplinks—with port pinning, uplink selection, and local port mirroring—are configured using satellite policies.

Satellite policies are configured as independent policies on the aggregation device, and then associated with the Junos Fusion configuration.

Understanding Environment Monitoring Satellite Policies

You can configure an environment monitoring satellite policy in a Junos Fusion to configure how a Junos Fusion responds to link-down alarms on satellite devices.

In the environment monitoring satellite policy, you define how you want a link-down alarm from a satellite device to be handled by the Junos Fusion. The Junos Fusion can treat the link-down alarm as a yellow or red alarm, or it can be configured to ignore the alarm.

The environment monitoring policy provides the flexibility to define different alarm handling based on user preference. You can, for instance, assign environment monitoring policies to individual satellite devices based on FPC ID. You can also configure environment monitoring policies based on the product model of the satellite devices, if desired. You can, for instance, specify that all link-down alarms from

EX4300 switches acting as satellite devices are treated as yellow alarms, while all link-down alarms from QFX5100 switches acting as satellite devices are treated as red alarms.

Environment monitoring satellite policies are configured using the ["environment-monitoring-policy" on page 123](#) statement in the [edit policy-options satellite-policies] hierarchy level.

An environment monitoring policy is applied for a single satellite device in a Junos Fusion using the [environment-monitoring-policy](#) statement in the [edit chassis "satellite-management" on page 141] or the [edit chassis "satellite-management" on page 141 "fpc" on page 125 slot-id] hierarchy levels.

You can configure a different environment monitoring policy for a single satellite device in the **fpc slot-id** when an environment monitoring policy for all satellite devices is configured. The environment monitoring policy for the FPC is enabled in cases when both an individual and global environment monitoring policy is configured.

RELATED DOCUMENTATION

[Configuring Junos Fusion Provider Edge](#)

[Configuring or Expanding a Junos Fusion Enterprise](#)

Understanding Multicast Forwarding on a Junos Fusion Enterprise

IN THIS SECTION

- [Overview of Multicast Forwarding | 47](#)
- [Configuring Layer 2 Multicast Forwarding in a Junos Fusion Enterprise | 48](#)
- [Configuring Layer 3 Multicast Forwarding in a Junos Fusion Enterprise | 48](#)

Starting with Junos OS Release 17.1R1, multicast traffic forwarding is supported in Junos Fusion Enterprise. Multicast forwarding is supported only on the aggregation device (AD).

Overview of Multicast Forwarding

The AD performs ingress multicast replication to a set of extended ports. On the satellite device, multicast traffic is received for each of the extended ports. The following scenarios are supported for both IPv4 and IPv6 traffic:

- Layer 2 multicast with VLAN flooding—IGMP snooping and the Multicast Learner Discovery (MLD) protocol are configured on the AD to forward multicast traffic
- Layer 3 multicast—IGMP and PIM are configured on the AD to forward multicast traffic. Only versions 2 and 3 of IGMP are supported.

Configuring Layer 2 Multicast Forwarding in a Junos Fusion Enterprise

To configure Layer 2 multicast forwarding in a Junos Fusion Enterprise, configure IGMP snooping and MLD snooping on each VLAN. The following example shows the basic configuration required. Virtual router instances with integrated routing and bridging (IRB) interfaces are also supported.

```

protocols {
  igmp-snooping {
    vlan team-a {
      interface ge-101/0/0.0 {
        multicast-router-interface;
      }
      interface ge-101/0/1.0 {
        static {
          group 233.252.0.1;
        }
      }
    }
    vlan team-b;
  }
}

```

Configuring Layer 3 Multicast Forwarding in a Junos Fusion Enterprise

To configure Layer 3 multicast forwarding in a Junos Fusion Enterprise, enable PIM and IGMP. The following example shows the basic configuration required. Note that an IRB interface are also required as the multicast traffic is forwarded through IRB interfaces.

```

protocols {
  igmp {
    accounting;
    interface all;
    interface irb.40 {
      version 2;
    }
  }
}

```

```
interface irb.50 {
  static {
    group 233.252.0.1;
  }
}
}
pim {
  rp {
    auto-rp discovery;
    static {
      address 192.0.2.1;
    }
  }
  interface all {
    mode sparse;
  }
}
}
```

RELATED DOCUMENTATION

[Junos Fusion Enterprise Overview](#) | 3

Junos Fusion Enterprise Configuration

IN THIS CHAPTER

- [Configuring or Expanding a Junos Fusion Enterprise | 50](#)
- [Junos Fusion Enterprise Installation Checklist | 72](#)
- [Adding a Switch Running Satellite Software to a Junos Fusion Enterprise | 86](#)
- [Enabling Configuration Synchronization Between Aggregation Devices in a Junos Fusion | 89](#)
- [Configuring Uplink Port Policies on a Junos Fusion | 94](#)
- [Configuring Satellite Device Alarm Handling Using an Environment Monitoring Satellite Policy in a Junos Fusion | 96](#)

Configuring or Expanding a Junos Fusion Enterprise

IN THIS SECTION

- [Preparing the Aggregation Devices | 51](#)
- [Preparing a Switch Running Junos OS to Become a Satellite Device | 52](#)
- [Configuring the FPC Slot IDs, Cascade Ports, and Satellite Device Clusters on the Junos Fusion | 54](#)
- [Managing Software Upgrade Groups on the Aggregation Device | 61](#)
- [Configuring the Dual Aggregation Device Topology \(Dual Aggregation Device Topologies Only\) | 64](#)
- [Installing Satellite Software and Adding Satellite Devices to the Junos Fusion | 69](#)

This topic provides the instructions needed to configure a Junos Fusion Enterprise—a Junos Fusion using EX9200 switches as aggregation devices—and to add satellite devices or an aggregation device to an existing Junos Fusion Enterprise. It covers:

Preparing the Aggregation Devices

Ensure your aggregation devices are running a version of Junos OS software that is compatible with Junos Fusion Enterprise. Junos Fusion Enterprise support was introduced for EX9200 switches in Junos OS Release 16.1R1. See [Junos Fusion Hardware and Software Compatibility Matrices](#) to learn more about Junos OS software compatibility requirements and to obtain Junos OS and satellite software for your Junos Fusion Enterprise. See "[Understanding Junos Fusion Enterprise Software and Hardware Requirements](#)" on page 29 for additional information on Junos Fusion Enterprise hardware and software requirements.

If the aggregation device does not have the correct version of Junos OS installed, upgrade the Junos OS on both Routing Engines on your aggregation device.

NOTE: If your aggregation device is part of an existing Junos Fusion Enterprise installation with satellite device clusters that is running Junos OS Release 16.1 and you wish to upgrade to Junos OS Release 17.1 or later, please refer to the upgrade instructions in the 17.1R1 release notes.

The following procedure shows one method of upgrading Junos OS software. The instructions assume that you know the basics of Junos OS image file management and have already acquired the target Junos OS image. The target Junos OS image can be obtained using the [Junos Fusion Hardware and Software Compatibility Matrices](#). This upgrade procedure causes avoidable system downtime.

The number of Junos OS software upgrade options available for EX9200 switches is beyond the scope of this document. For information on Junos OS software installation options for EX9200 switches, see the [Software Installation and Upgrade Guide](#).

To upgrade Junos OS software, enter the following commands on the aggregation device:

```
user@aggregation-device> request system software add aggregation-device-package-name re0
```

```
user@aggregation-device> request system software add aggregation-device-package-name re1
```

After performing the upgrade, reboot both Routing Engines to complete the software upgrade.

```
user@aggregation-device> request system reboot both-routing-engines
```

Preparing a Switch Running Junos OS to Become a Satellite Device

Use this procedure to prepare all switches running Junos OS software to become satellite devices. This procedure must be performed on all satellite devices, regardless of whether the satellite device will be converted into a standalone satellite device or be part of a satellite device cluster.

This section can be skipped if your satellite device or all satellite devices in your satellite device cluster are already running satellite software.

NOTE: The following conditions must be met before a Junos switch that is running Junos OS Release 17.1R1 can be converted to a satellite device when the action is initiated from the aggregation device:

- The Junos switch can only be converted to SNOS 3.0 and higher.
- The Junos switch must be either set to factory default configuration, or the following command must be included in the configuration: `set chassis satellite-management auto-satellite-conversion.`

To prepare a switch running Junos OS software to become a satellite device:

1. Log into the device that will become a satellite device through the console port.
2. Ensure the device is running a version of Junos OS that allows it to be converted into a satellite device. See [Junos Fusion Hardware and Software Compatibility Matrices](#) and "[Understanding Junos Fusion Enterprise Software and Hardware Requirements](#)" on [page 29](#) for information on minimum Junos OS requirements for satellite devices.

NOTE: In case of difficulty moving to the required versions of U-boot and JLOADER, please contact the Juniper Networks Technical Assistance Center.

If you need to upgrade Junos OS on your satellite device before proceeding, see the [Junos Fusion Hardware and Software Compatibility Matrices](#) to obtain the software. Upgrade Junos OS before converting your switch into a satellite device.

3. (Satellite devices providing interfaces for PoE only) If you plan on using the satellite device interfaces to provide PoE, check the satellite device's PoE firmware version:
 - Enter the **show chassis firmware detail** command to learn the PoE firmware version running on the device.

```
user@sd1-ex4300> show chassis firmware detail
FPC 0
```

```

Boot SYSPLD          10
PoE firmware         2.6.3.92.1
(additional output omitted)

```

- The satellite device must have the following minimum PoE versions to support PoE in a Junos Fusion Enterprise.

Table 10: Minimum PoE Firmware Versions

Satellite Device Platform	Minimum PoE Firmware Version
EX2300	1.6.1.1.9
EX3400	1.6.1.1.9
EX4300	2.6.3.92.1
QFX5100	No minimum version requirement

See [Minimum Satellite Device Firmware Version Requirements table](#) for additional information on firmware version requirements for devices in a Junos Fusion Enterprise.

- If your device meets the minimum PoE firmware requirement, proceed to the next step.
If a PoE firmware update is required, upgrade the PoE firmware. See [Upgrading the PoE Controller Software](#).

4. Zeroize the device:

```

[edit]
user@satellite-device# request system zeroize

```

NOTE: The device reboots to complete the procedure for zeroizing the device.

If you are not logged into the device using the console port connection, your connection to the device is lost after entering the **request system zeroize** command.

If you lose your connection to the device, log in using the console port.

5. (EX3400 and EX4300 switch uplink ports only) After the reboot is complete, convert the built-in 40-Gbps interfaces with QSFP+ transceivers from Virtual Chassis ports (VCPs) into network ports:

```
user@satellite-device> request virtual-chassis vc-port delete pic-slot 1 port port-number
```

For example, to convert all four built-in 40-Gbps interfaces with QSFP+ transceivers on an EX4300-24P switch into network ports:

```
user@satellite-device>request virtual-chassis vc-port delete pic-slot 1 port 0
user@satellite-device> request virtual-chassis vc-port delete pic-slot 1 port 1
user@satellite-device> request virtual-chassis vc-port delete pic-slot 1 port 2
user@satellite-device> request virtual-chassis vc-port delete pic-slot 1 port 3
```

The number of built-in 40-Gbps interfaces with QSFP+ transceivers varies by switch model. See the hardware documentation for your switch.

This step is required for the 40-Gbps interfaces with QSFP+ transceivers that will be used as uplink interfaces to directly connect to the aggregation device in a Junos Fusion Enterprise, because zeroizing the devices restores the default settings and 40-Gbps interfaces with QSFP+ transceivers on EX3400 and EX4300 switches are configured into VCPs by default. VCPs cannot be used as uplink ports to connect to aggregation devices in a Junos Fusion.

6. Commit the configuration.

```
user@satellite-device# commit
```

Configuring the FPC Slot IDs, Cascade Ports, and Satellite Device Clusters on the Junos Fusion

IN THIS SECTION

- [Configuring the FPC Slot ID and Cascade Ports for a Standalone Satellite Device | 55](#)
- [Configuring the FPC Slot ID, Cascade Ports, and Satellite Device Clusters for Satellite Devices in a Satellite Device Cluster | 58](#)

Use this procedure to configure FPC slot IDs, cascade ports, and satellite device clusters.

For more information on FPC slot IDs, cascade ports, and satellite device clusters, see "[Understanding Junos Fusion Enterprise Components](#)" on page 6.

This section provides separate instructions for configuring FPC slot IDs and cascade ports for standalone satellite devices and satellite devices in a satellite device cluster. A Junos Fusion Enterprise can and often does support standalone satellite devices and satellite device clusters in the same Junos Fusion topology.

This section covers the following procedures:

Configuring the FPC Slot ID and Cascade Ports for a Standalone Satellite Device

Use this procedure to configure the FPC slot IDs and cascade ports for standalone satellite devices, which are satellite devices that are not part of a satellite device cluster:

1. Configure the cascade ports, and commit the configuration.

A cascade port is a port on an aggregation device that connects to a satellite device or a satellite device cluster. Data and control traffic is passed between the aggregation device and the satellite devices over the cascade port link.

To configure a cascade port:

```
[edit]
user@aggregation-device# set interfaces interface-name cascade-port
```

where *interface-name* in the cascade port interface on the aggregation device.

For example, to configure interface xe-0/0/1 on the aggregation device into a cascade port:

```
[edit]
user@aggregation-device# set interfaces xe-0/0/1 cascade-port
```

Commit the configuration on both Routing Engines:

```
[edit]
user@aggregation-device# commit synchronize
```

or onto a single Routing Engine:

```
[edit]
user@aggregation-device# commit
```

2. Configure the FPC slot ID number of each satellite device.

In a Junos Fusion Enterprise, each satellite device, including each satellite device in a satellite device cluster, must be mapped to an FPC identifier (FPC ID). The FPC ID is in the range of 65 through 255, and it is used for Junos Fusion Enterprise configuration, monitoring, and maintenance. Interface names—which are identified using the *type-fpc / pic / port* format—use the FPC ID as the *fpc* variable when the satellite device is participating in a Junos Fusion Enterprise.

You can assign an FPC identifier to the satellite device based on either the satellite device's MAC address, serial number, or cascade port.

- To map the FPC slot ID to a standalone satellite device's MAC address:

```
[edit]
user@aggregation-device# set chassis satellite-management fpc slot-id system-id mac-address
```

where *slot-id* becomes the FPC slot ID of the satellite device and *mac-address* is the satellite device's MAC address. The FPC slot ID must be 65 or larger, and it functions as the FPC slot identifier.

For example, to map FPC slot ID to the satellite device using MAC address 00:00:5E:00:53:00:

```
[edit]
user@aggregation-device# set chassis satellite-management fpc 110 system-id
00:00:5E:00:53:00
```

NOTE: To find out the system MAC of the satellite device, use the `show chassis mac-addresses` command on the satellite device.

- To map the FPC slot ID to a standalone satellite device's serial number:

```
[edit]
user@aggregation-device# set chassis satellite-management fpc slot-id serial-number serial-
number
```

where *slot-id* becomes the FPC slot ID of the satellite device and *serial-number* is the satellite device's serial number. The FPC slot ID must be 65 or larger, and it functions as the FPC slot identifier.

For instance, to map FPC slot ID 101 to the satellite device using the serial number ABCDEFGHIJKL:

```
[edit]
user@aggregation-device# set chassis satellite-management fpc 101 serial-number
ABCDEFGHIJKL
```

NOTE: To find out the serial number of the satellite device, use the `show chassis hardware` command on the satellite device.

- To configure the FPC slot ID for a standalone satellite device—a satellite device not part of a satellite device cluster—to a cascade port, enter:

```
[edit]
user@aggregation-device# set chassis satellite-management fpc slot-id cascade-ports
interface-name
```

where *slot-id* becomes the FPC slot ID of the satellite device, and *interface-name* is the name of the interface.

For example, to configure the FPC slot ID of the satellite device that is connected to xe-0/0/1 to 101:

```
[edit]
user@aggregation-device# set chassis satellite-management fpc 101 cascade-ports xe-0/0/1
```

If a prospective satellite device is connected to a Junos Fusion Enterprise without having a configured FPC slot ID, the prospective satellite device does not participate in the Junos Fusion Enterprise until an FPC ID is associated with it. The **show chassis satellite unprovision** output includes a list of satellite devices that are not participating in a Junos Fusion Enterprise because of an FPC ID association issue.

The FPC slot ID configuration must match on both aggregation devices in dual-homed dual aggregation device topologies.

Configuring the FPC Slot ID, Cascade Ports, and Satellite Device Clusters for Satellite Devices in a Satellite Device Cluster

Use this procedure to configure the FPC slot IDs, cascade ports, and satellite device clusters for satellite devices in a satellite device cluster:

1. Configure the cascade ports, and commit the configuration.

A cascade port is a port on an aggregation device that connects to a satellite device in a satellite device cluster. An aggregation device can have multiple cascade ports connecting to multiple satellite device member switches in the same satellite device cluster. Data and control traffic is passed between the aggregation device and the satellite devices over a cascade port link.

BEST PRACTICE: Use the `show interfaces` command to confirm your interface is up before configuring it into a cascade port.

To configure a cascade port:

```
[edit]
user@aggregation-device# set interfaces interface-name cascade-port
```

For example, to configure interface `xe-0/0/1` on the aggregation device into a cascade port:

```
[edit]
user@aggregation-device# set interfaces xe-0/0/1 cascade-port
```

Commit the configuration on both Routing Engines:

```
[edit]
user@aggregation-device# commit synchronize
```

or onto a single Routing Engine:

```
[edit]
user@aggregation-device# commit
```

2. Create the satellite device clusters, and assign a name and a cluster ID to each satellite device cluster:

```
[edit]
user@aggregation-device# set chassis satellite-management cluster cluster-name cluster-id
cluster-id-number
```

For instance, to create a satellite device cluster named `building-1` and assign it cluster ID 1:

```
[edit]
user@aggregation-device# set chassis satellite-management cluster building-1 cluster-id 1
```

The `cluster-name` and `cluster-id-number` specified in this step must match on both aggregation devices in dual aggregation device topologies.

3. Define the cascade ports associated with the satellite device cluster.

An aggregation device can have multiple cascade port connections to the satellite devices in the satellite device cluster, and it must have at least one cascade port connection to one of the satellite devices in the satellite device cluster.

For example, to configure interfaces `xe-0/0/1` and `xe-0/0/2` on the aggregation device into cascade ports connecting to the satellite device cluster named `building-1`:

```
[edit]
user@aggregation-device# set chassis satellite-management cluster building-1 cascade-ports
xe-0/0/1
user@aggregation-device# set chassis satellite-management cluster building-1 cascade-ports
xe-0/0/2
```

NOTE: This step defines which aggregation device ports will be used as cascade ports with the satellite device cluster only.

The aggregation device interfaces still must be configured into cascade ports, which is accomplished in step 1 of this procedure.

4. Configure the FPC slot ID number of each satellite device.

In a Junos Fusion Enterprise, each satellite device, including each satellite device in a satellite device cluster, must be mapped to an FPC identifier (FPC ID). The FPC ID is in the range of 65 through 255, and it is used for Junos Fusion Enterprise configuration, monitoring, and maintenance. Interface names—which are identified using the `type-fpc / pic / port` format—use the FPC ID as the `fpc` variable when the satellite device is participating in a Junos Fusion Enterprise.

- To map the FPC slot ID to the MAC address of a satellite device in a satellite device cluster:

NOTE: You must map the FPC slot ID to the satellite device's MAC address when the satellite device is a member of a satellite device cluster.

```
[edit]
user@aggregation-device# set chassis satellite-management cluster cluster-name fpc slot-ID
system-id mac-address
```

where *cluster-name* is the name of the satellite device cluster, *slot-id* becomes the FPC slot ID of the satellite device, and *mac-address* is the satellite device's MAC address. The FPC slot ID must be 65 or larger, and it functions as the FPC slot identifier.

For instance, to map FPC slot ID 101 to the satellite device using MAC address 00:00:5E:00:53:00, FPC slot ID 102 to the satellite device using MAC address 00:00:5E:00:53:01, and FPC slot 103 to the satellite device using MAC address 00:00:5E:00:53:02 in the satellite device cluster named building-1:

```
[edit]
user@aggregation-device# set chassis satellite-management cluster building-1 fpc 101
system-id 00:00:5E:00:53:00
user@aggregation-device# set chassis satellite-management cluster building-1 fpc 102
system-id 00:00:5E:00:53:01
user@aggregation-device# set chassis satellite-management
cluster building-1 fpc 103 system-id 00:00:5E:00:53:02
```

NOTE: To find out the system MAC of the satellite device, use the `show chassis mac-addresses` command on the satellite device.

5. Assign a member ID to each satellite device in the satellite device cluster:

```
[edit]
user@aggregation-device# set chassis satellite-management cluster cluster-name fpc fpc-slot-ID
member-id member-ID-number
```

For instance, to assign member ID numbers 1,2, and 3 to FPC ID numbers 101, 102, and 103 in the satellite device cluster named `building-1`:

```
[edit]
user@aggregation-device# set chassis satellite-management cluster building-1 fpc 101 member-
id 1
user@aggregation-device# set chassis satellite-management cluster building-1 fpc 102 member-
id 2
user@aggregation-device# set chassis satellite-management cluster building-1 fpc 103 member-
id 3
```

The member ID assignments for a satellite device cluster must match on both Routing Engines in a dual aggregation device topology.

6. (Dual-homed dual aggregation device topologies only) Repeat this procedure to configure the FPC slot IDs, cascade ports, and satellite device clusters on the other aggregation device.

NOTE: The cluster name, ID and FPC information for each satellite device in the cluster must be the same on both aggregation devices.

Managing Software Upgrade Groups on the Aggregation Device

A satellite software upgrade group is a group of satellite devices that are designated to run the same satellite software version using the same satellite software package. One Junos Fusion Enterprise can contain multiple software upgrade groups, and multiple software upgrade groups should be configured in most Junos Fusion Enterprises to avoid network downtimes during satellite software installations.

When a satellite device is added to a Junos Fusion Enterprise, the aggregation device checks if the satellite device is using an FPC ID that is included in a satellite software upgrade group. If the satellite device is using an FPC ID that is part of a satellite software upgrade group, the device upgrades its satellite software to the version of software associated with the satellite software upgrade group - unless it is already running the defined version.

When the satellite software package associated with an existing satellite software group is changed, the satellite software for all member satellite devices is upgraded using a throttled upgrade. The throttled upgrade ensures that the aggregation device is not overwhelmed with providing satellite software simultaneously to many satellite devices.

The two most common methods for installing satellite software onto a Junos OS device—autoconverting a device into a satellite device when it is cabled into an aggregation device and manually converting a device that is cabled into an aggregation device into a satellite device—require that a satellite software upgrade group is configured.

Software upgrade groups are managed from the aggregation device. All satellite devices in a satellite device cluster are part of the same software upgrade group, and a software upgrade group with the name of the satellite device cluster is automatically created when the satellite device cluster is created.

To manage a software upgrade group:

1. Log into the aggregation device.
2. Download the satellite software onto both aggregation devices (recommended) or onto a remote server.

The satellite software can be downloaded from the main Junos Fusion software download page:

[Junos Fusion - Download Software](#)

3. (Standalone satellite device only) Create a satellite software upgrade group, and associate the standalone satellite device with the satellite software upgrade group:

```
[edit]
user@aggregation-device# set chassis satellite-management upgrade-groups upgrade-group-name
satellite slot-id-number-or-range
```

where *upgrade-group-name* is the name of the upgrade group, and the *slot-id-number-or-range* is the FPC slot ID number or range of numbers, of the satellite devices that are being added to the upgrade group.

NOTE: If you enter the name of an existing satellite software upgrade group as the *upgrade-group-name*, the specified satellite devices are added to the existing software upgrade group.

For example, to create a software upgrade group named **group1** that includes all satellite devices numbered 101 through 120:

```
[edit]
user@aggregation-device# set chassis satellite-management upgrade-groups group1 satellite
101-120
```

The satellite software upgrade group name and associated FPC slot ID configurations must match on both Routing Engines in a dual-homed dual aggregation device topology.

4. Commit the configuration to both Routing Engines on the aggregation device:

```
[edit]
user@aggregation-device# commit synchronize
```

If you are using an aggregation device with a single Routing Engine or want to commit the configuration to a single Routing Engine only:

```
[edit]
user@aggregation-device# commit
```

The configuration must be committed before associating a satellite software image with the satellite software upgrade group, which is done in Step 5.

5. Associate the satellite software upgrade group with a satellite software image.

- Satellite device clusters:
 - Associate all satellite devices in the cluster with the automatically-created satellite software upgrade group:

```
user@aggregation-device> request system software add package-name upgrade-group
upgrade-group-name
```

where *package-name* is the URL to the satellite software package, and *upgrade-group-name* is the name of the satellite device cluster.

For example, to associate a satellite software image named **satellite-3.0R1.2-signed.tgz** that is currently stored in the **/var/tmp** directory on the aggregation device to the upgrade group named **building1**:

```
user@aggregation-device> request system software add /var/tmp/satellite-3.0R1.2-
signed.tgz upgrade-group building1
```

- Standalone satellite devices:
 - Associate the satellite device with the previously-configured satellite software upgrade group:

```
user@aggregation-device> request system software add package-name upgrade-group
upgrade-group-name
```

where *package-name* is the URL to the satellite software package, and *upgrade-group-name* is the name of the upgrade group that was assigned by the user earlier in this procedure.

For example, to associate a satellite software image named **satellite-3.0R1.2-signed.tgz** that is currently stored in the **/var/tmp** directory on the aggregation device to the upgrade group named **group1**:

```
user@aggregation-device> request system software add /var/tmp/satellite-3.0R1.2-  
signed.tgz upgrade-group group1
```

Associating a satellite software image to a new satellite software package can trigger a satellite software upgrade. A throttled satellite software upgrade might begin after entering the **request system software add** command to associate a satellite software package with a satellite software upgrade group. A satellite software upgrade might also be triggered when a configuration that uses the satellite software upgrade group is committed.

6. (Dual-homed dual aggregation device topology only) Repeat Steps 1 through 4 using the exact same configuration—including the same *package-name* and *upgrade-group-name*—to configure software upgrade groups on the second aggregation device.

The software upgrade group configurations must match in dual aggregation topologies for the satellite software upgrade to proceed. If you do not associate the software upgrade group on the second aggregation device with a satellite software version, then the satellite device software upgrade will be managed only by the other aggregation device. If you associate the software upgrade group on the second aggregation with a satellite software version, then the satellite software version must be the same on both aggregation devices.

Configuring the Dual Aggregation Device Topology (Dual Aggregation Device Topologies Only)

Use this procedure to connect and configure a second aggregation device into a Junos Fusion Enterprise topology.

Before you begin:

- Ensure that a Junos Fusion topology has already been configured, and that the topology includes a satellite software upgrade group.
- Ensure that the aggregation devices are already cabled together and that all cabling to all satellite devices has been completed for both aggregation devices. For information on cabling requirements, see "[Understanding Junos Fusion Enterprise Software and Hardware Requirements](#)" on page 29.

1. (Required only if aggregation device was previously configured into single home mode) Delete single home configuration mode:

On aggregation device 1 and 2:

```
[edit]
```

```
user@aggregation-device# delete chassis satellite-management single-home
```

NOTE: Single home mode is not supported in a dual-aggregated device Junos Fusion Enterprise topology.

2. Create and configure a redundancy group on the first aggregation device.

A dual aggregation device topology in a Junos Fusion is a multichassis link aggregation group (MC-LAG) that uses the Inter-Chassis Communications Protocol (ICCP) to communicate between the aggregation devices. ICCP is typically used in an MC-LAG to exchange information between MC-LAG peers. The MC-LAG peers in a Junos Fusion dual aggregation topology are the aggregation devices.

A redundancy group is required to enable ICCP in a Junos Fusion. A Junos Fusion topology supports one redundancy group that includes two member devices—the aggregation devices—while also including a configuration parameter that allows users to specify that the satellite devices or satellite clusters also belong to the redundancy group.

NOTE: All satellite devices, whether standalone satellites or satellite clusters, must be associated to a redundancy group on both aggregated devices; otherwise, they act as single-homed devices, which are not supported in a dual-aggregation device Junos Fusion Enterprise topology.

To create and configure the redundancy group on the first aggregation device:

- a. Specify the redundancy group ID number on both aggregation devices. The redundancy group name is created and named as part of this process.

The redundancy group ID number and name must match on both aggregation devices.

On aggregation device 1 and 2:

```
[edit chassis satellite-management redundancy-groups]
```

```
user@aggregation-device# set redundancy-group-name redundancy-group-id redundancy-group-id-number
```

For instance, to create a redundancy group named `junos-fusion-campus-network` that uses redundancy group ID 1 on aggregation device 1:

```
[edit chassis satellite-management redundancy-groups]
user@aggregation-device# set junos-fusion-campus-network redundancy-group-id 1
```

Repeat this procedure on aggregation device 2:

```
[edit chassis satellite-management redundancy-groups]
user@aggregation-device# set junos-fusion-campus-network redundancy-group-id 1
```

- b. Define the chassis ID number of the each aggregation device:

```
[edit chassis satellite-management redundancy-groups]
user@aggregation-device# set chassis-id chassis-id-number
```

For instance, to assign the aggregation device 1 the chassis ID of 1 for the `junos-fusion-campus-network` redundancy group:

```
[edit chassis satellite-management redundancy-groups]
user@aggregation-device# set chassis-id 1
```

To assign aggregation device 2 the chassis ID of 2 for the `junos-fusion-campus-network` redundancy group:

```
[edit chassis satellite-management redundancy-groups]
user@aggregation-device# set chassis-id 2
```

The chassis ID numbers cannot match and are used to create the ICL that interconnects the aggregation device in the Junos Fusion topology.

- c. Define the peer chassis ID number—the chassis ID number of the other aggregation device—and interface to use for the ICL:

```
[edit chassis satellite-management redundancy-groups]
user@aggregation-device# set redundancy-group-name peer-chassis-id peer-chassis-id-number
inter-chassis-link interface-name
```

For instance, to use the xe-0/0/1 interface on aggregation device 1 to create an ICL that connects to aggregation device 2:

```
[edit chassis satellite-management redundancy-groups]
user@aggregation-device# set junos-fusion-campus-network peer-chassis-id 2 inter-chassis-link xe-0/0/1
```

To complete the configuration by defining the peer chassis ID and interface on aggregation device 2:

```
[edit chassis satellite-management redundancy-groups]
user@aggregation-device# set junos-fusion-campus-network peer-chassis-id 1 inter-chassis-link xe-0/0/1
```

The ICL is used to pass traffic between the aggregation devices.

- d. Define the satellite devices that are part of the redundancy group.

You can add a standalone satellite device or a satellite device cluster to the redundancy group in this step.

The satellite devices added to the redundancy group in this step must match on both redundancy groups.

All satellite devices in the Junos Fusion should be added to the redundancy group in this step.

- To add standalone satellite devices to the redundancy group:

```
[edit chassis satellite-management redundancy-groups]
user@aggregation-device# set redundancy-group-name satellite satellite-device-fpc-IDs
```

For instance, to include satellite devices using FPC IDs 100-140 in the redundancy group:

```
[edit chassis satellite-management redundancy-groups]
user@aggregation-device# set junos-fusion-campus-network satellite 100-140
```

- To add a satellite device cluster to the redundancy group:

```
[edit chassis satellite-management redundancy-groups]
user@aggregation-device# set redundancy-group-name cluster cluster-name
```

For instance, to include satellite device cluster **building-1** to the redundancy group:

```
[edit chassis satellite-management redundancy-groups]
user@aggregation-device# set junos-fusion-campus-network cluster building-1
```

Repeat the same configuration steps on the other aggregation device.

For instance:

```
[edit chassis satellite-management redundancy-groups]
user@aggregation-device# set junos-fusion-campus-network satellite 100-140
user@aggregation-device# set junos-fusion-campus-network cluster building-1
```

3. (Recommended) Ensure at least one link besides the ICL is connecting the aggregation devices. This link automatically becomes the ICCP link.

An ICCP link can be one link or an aggregated ethernet interface. In most Junos Fusion Enterprise deployments, we recommend using a 40-Gbps link or an aggregated ethernet interface as the ICCP link.

An ICCP link is recommended but is optional because ICCP traffic is transmitted across the ICL when a dedicated ICCP link is not configured.

ICCP configuration is not required. ICCP is automatically provisioned in a Junos Fusion using dual aggregation devices, by default. User configuration of ICCP is not required and is only recommended for expert users.

If you configure an ICCP parameter in a Junos Fusion, the user-configured parameter overrides the automatically provisioned parameter for the configured parameter only.

You can disable automatic ICCP provisioning using the ["no-auto-iccp-provisioning"](#) on page 133 statement.

If you decide to configure ICCP, you must configure matching configurations on both aggregation devices.

NOTE: ICCP configuration is beyond the scope of this document. See [Getting Started with MC-LAG](#).

4. Configure ICCP.

ICCP can be configured in one of the following ways:

- Automatic ICCP provisioning

Automatic ICCP provisioning automatically configures ICCP in a dual aggregation device setup without any user action. Automatic ICCP provisioning is enabled by default and is often the preferred method of enabling ICCP for a Junos Fusion in greenfield deployments that are not being integrated into an existing network.

No user action is required to configure ICCP if automatic ICCP provisioning is used.

- Manual ICCP configuration.

Manual ICCP configuration is typically used to integrate a Junos Fusion Enterprise into an existing network or by expert users that want to finely tune ICCP settings.

Many Junos Fusion Enterprise installations occur in brownfield deployments and the Junos Fusion Enterprise has to be integrated into an existing Enterprise network. Brownfield deployments often have a need to maintain existing ICCP settings, in particular in scenarios where a Junos Fusion Enterprise is replacing an MC-LAG topology or is supporting a network that includes other MC-LAG topologies. ICCP must be configured manually in these scenarios.

See [Getting Started with MC-LAG](#) for the steps and options available to configure ICCP.

If you configure an ICCP parameter in a Junos Fusion, the user-configured parameter overrides the automatically provisioned parameter for the configured parameter only. You can disable all automatic ICCP provisioning using the `"no-auto-iccp-provisioning"` on [page 133](#) statement.

If you decide to manually configure ICCP, you must configure matching configurations on both aggregation devices.

Installing Satellite Software and Adding Satellite Devices to the Junos Fusion

Use this procedure to install satellite software onto a satellite device. A satellite device is not active in a Junos Fusion until satellite software is installed.

Before you begin:

- Ensure you have prepared your satellite device, as described in the “Preparing a Switch Running Junos OS to Become a Satellite Device” section.
- Ensure that the satellite software package is compatible with the aggregation device software. See *Junos Fusion Hardware and Software Compatibility Matrices* at <https://www.juniper.net/support/downloads/solutions/fusion/>.
- Ensure the minimum satellite device version requirements are met. For information on requirements, see ["Understanding Junos Fusion Enterprise Software and Hardware Requirements"](#) on [page 29](#).

- Complete the other steps in this document—created cascade ports, associated FPC slot IDs with satellite devices, and created the satellite software upgrade groups—to ensure the satellite software can be successfully installed.

To install satellite software onto a satellite device and add it to the Junos Fusion Enterprise.

1. Decide how satellite software will be installed onto the satellite devices:

- Autoconversion(Recommended)—Satellite software is installed onto satellite device automatically when it is cabled to the aggregation device.
- Manual conversion—Satellite software is installed when user enters a CLI command from aggregation device to install satellite software.
- Pre-installation—Satellite software is installed on satellite device before the satellite device is cabled into the Junos Fusion Enterprise.

2. Install the satellite software, or configure how it will be installed:

- To enable autoconversion for a standalone satellite device or a satellite device in a satellite device cluster, enter the following commands from an aggregation device:

```
[edit]
user@aggregation-device# set chassis satellite-management auto-satellite-conversion
satellite slot-id
user@aggregation-device# commit
```

For example, to automatically convert FPC **101** into a satellite device:

```
[edit]
user@aggregation-device# set chassis satellite-management auto-satellite-conversion
satellite 101
user@aggregation-device# commit
```

In this example, autoconversion installs the satellite software associated with FPC slot 101, which was defined in the satellite software upgrade group configuration.

The process to install the satellite software onto the satellite device with the specified FPC slot ID does not begin until the configuration is committed.

- To manually install satellite software onto a satellite device, enter the following command from an aggregation device:

```
user@aggregation-device> request chassis satellite interface interface-name device-mode
satellite
```

where *interface-name* is one of the following values:

- standalone satellite device: the *interface-name* is the cascade port interface on the aggregation device.
- satellite device in satellite device cluster that is directly cabled to the aggregation device: the *interface-name* is the cascade port interface on the aggregation device.
- satellite device in satellite device cluster that is not directly cabled to an aggregation device: the *interface-name* is a clustering port—a port on a satellite device in a satellite device cluster that interconnects satellite devices—on a satellite device.

For example, to manually configure the switch that is connecting the satellite device to interface xe-0/0/1 on the aggregation device into a satellite device:

```
user@aggregation-device> request chassis satellite interface xe-0/0/1 device-mode satellite
```

To manually configure a switch connecting to interface xe-101/2/0 on a satellite device in a satellite device cluster into a satellite device:

```
user@aggregation-device> request chassis satellite interface xe-101/2/0 device-mode
satellite
```

- To pre-install software onto a satellite device before connecting it into the Junos Fusion Enterprise:

- a. Copy a version of satellite software onto the satellite device running Junos OS.

For EX2300, EX3400, and EX4300 switches, you must install a platform specific satellite software image in order to pre-install satellite software. See *Understanding the Platform Specific Satellite Software Image* in "[Understanding Software in a Junos Fusion Enterprise](#)" on [page 25](#).

Satellite software images can be downloaded from the [Junos Fusion software download page](#).

- b. Enter the following command from the satellite device:

```
user@satellite-device> request chassis device-mode satellite URL-to-satellite-software
```

For instance, to install the satellite software package `satellite-ppc-3.0R1.2-signed.tgz` stored in the `/var/tmp/` folder on an EX4300 switch:

```
user@satellite-device> request chassis device-mode satellite /var/tmp/satellite-ppc-3.0R1.2-signed.tgz
```

- c. Cable the satellite device directly to the aggregation device or into a satellite device cluster.

NOTE: The satellite device version is compared against the satellite device version associated with the software upgrade group upon insertion into the Junos Fusion. If the satellite device is running a version of satellite software that is different than it's associated satellite software upgrade group, the satellite software upgrade group installs the satellite software associated with the satellite software upgrade group onto the satellite device.

The procedure for adding a satellite device running satellite software into a Junos Fusion is also covered in "[Adding a Switch Running Satellite Software to a Junos Fusion Enterprise](#)" on page 86.

RELATED DOCUMENTATION

[Junos Fusion Hardware and Software Compatibility Matrices](#)

[Understanding Junos Fusion Enterprise Software and Hardware Requirements](#)

[Verifying Connectivity, Device States, Satellite Software Versions, and Operations in a Junos Fusion | 161](#)

[Understanding Junos Fusion Enterprise Components | 6](#)

[Understanding Software in a Junos Fusion Enterprise | 25](#)

Junos Fusion Enterprise Installation Checklist

The checklist in [Table 11 on page 73](#) summarizes the tasks you need to perform when installing a Junos Fusion Enterprise. This checklist should be used with the "[Configuring or Expanding a Junos](#)

[Fusion Enterprise" on page 50](#) document, which provides detailed step-by-step instructions for configuring a Junos Fusion Enterprise.

NOTE: If your aggregation device is part of an existing Junos Fusion Enterprise installation with satellite device clusters that is running Junos OS Release 16.1 and you want to upgrade to Junos OS Release 17.1 or later, please refer to the upgrade instructions in the Junos OS 17.1R1 Release Notes.

Table 11: Junos Fusion Enterprise Installation Checklist

Task	Additional Information	For More Information	Performed by and Date
Prepare Aggregation Device (Aggregation Devices)			
Install a supported version of Junos OS onto each aggregation device.	EX9200 switches can act as aggregation devices in a Junos Fusion Enterprise when running Junos OS Release 16.1R1 or later.	Junos Fusion main software download page and software support matrix: Junos Fusion - Download Software Junos Fusion Enterprise software requirements: Junos Fusion Hardware and Software Compatibility Matrices EX9200 switch software installation: Software Installation and Upgrade Guide Junos Fusion Enterprise software overview: "Understanding Software in a Junos Fusion Enterprise" on page 25	
Prepare Satellite Devices (Satellite Devices)			

Table 11: Junos Fusion Enterprise Installation Checklist (*Continued*)

Task	Additional Information	For More Information	Performed by and Date
<p>Ensure each satellite device is running a version of Junos OS that allows it to be converted into a satellite device.</p>	<p>EX2300 and EX3400 switches must be running Junos OS Release 15.1X53-D55 or later to be converted into a satellite device.</p> <p>EX4300 switches must be running Junos OS Release 14.1X53-D43 or later to be converted into a satellite device.</p> <p>QFX5100 switches must be running Junos OS Release 14.1X53-D43 or later to be converted into a satellite device.</p>	<p>Satellite device software requirements: Junos Fusion Hardware and Software Compatibility Matrices</p> <p>Upgrading Junos OS on an EX2300, EX3400, or EX4300 switch: Software Installation and Upgrade Guide</p> <p>Upgrading Junos OS on a QFX5100 switch: Installing Software Packages on QFX Series Devices</p>	
<p>Zeroize each satellite device.</p>	<p>BEST PRACTICE: Perform this procedure from the console port.</p> <p>To zeroize a satellite device:</p> <pre>request system zeroize</pre>	<p>Zeroizing a switch:</p> <ul style="list-style-type: none"> • request system zeroize • <i>Reverting to the Default Factory Configuration for the EX Series Switch</i> 	

Table 11: Junos Fusion Enterprise Installation Checklist (*Continued*)

Task	Additional Information	For More Information	Performed by and Date
<p>(EX3400 and EX4300 switches only) Convert the built-in 40-Gbps interfaces from Virtual Chassis ports (VCPs) to network ports.</p>	<p>The number of built-in 40-Gbps interfaces with QSFP+ transceivers varies by EX4300 switch model.</p> <p>To convert four built-in 40-Gbps interfaces with QSFP+ transceivers on an EX4300 switch:</p> <pre>request virtual-chassis vc-port delete pic-slot 1 port 0 request virtual-chassis vc-port delete pic-slot 1 port 1 request virtual-chassis vc-port delete pic-slot 1 port 2 request virtual-chassis vc-port delete pic-slot 1 port 3</pre>	<p>Deleting a VCP: <i>request virtual-chassis vc-port</i></p>	
Configure Cascade Ports and FPC slot IDs (Aggregation Devices)			
<p>Configure cascade ports on the aggregation devices.</p>	<p>A cascade port is a port on the aggregation device that connects to a satellite device.</p> <p>To configure a cascade port:</p> <pre>set interfaces xe-0/0/1 cascade-port</pre>	<p>Cascade port overview: "Understanding Junos Fusion Enterprise Components" on page 6</p> <p>Cascade port configuration:</p> <ul style="list-style-type: none"> • "Configuring or Expanding a Junos Fusion Enterprise" on page 50 • "cascade-port" on page 110 	

Table 11: Junos Fusion Enterprise Installation Checklist (*Continued*)

Task	Additional Information	For More Information	Performed by and Date
<p>(Satellite device clusters only) Create and number the satellite device clusters.</p> <p>NOTE: You can skip this step if you are not using satellite device clusters.</p>	<p>Satellite device clustering allows you to connect up to ten satellite devices into a single cluster, then connect the satellite device cluster to the aggregation device as a single group instead of as individual satellite devices.</p> <p>This configuration must match on both aggregation devices.</p> <p>To create and number a satellite device cluster:</p> <pre>set chassis satellite-management cluster sd-cluster-building1 cluster-id 1</pre>	<p>Satellite device clustering overview: "Understanding Satellite Device Clustering in a Junos Fusion" on page 15</p> <p>Satellite device clustering configuration:</p> <ul style="list-style-type: none"> • "Configuring or Expanding a Junos Fusion Enterprise" on page 50 • "cluster-id" on page 117 	
<p>(Satellite device clusters only) Associate the satellite device clusters with a cascade port.</p>	<p>To associate a cascade port with a satellite device cluster:</p> <pre>set chassis satellite-management cluster sd-cluster-building1 cascade-ports xe-0/0/1</pre>	<p>Satellite device clustering configuration: "Configuring or Expanding a Junos Fusion Enterprise" on page 50</p>	

Table 11: Junos Fusion Enterprise Installation Checklist (*Continued*)

Task	Additional Information	For More Information	Performed by and Date
<p>Configure the FPC slot Identifiers (IDs) using one of the following methods on both aggregation devices:</p> <ul style="list-style-type: none"> map FPC slot ID to a satellite device's MAC address (unique ID-based FPC identification) map FPC slot ID to a satellite device's serial number (unique ID-based FPC identification) map FPC slot ID with a cascade port (connectivity-based FPC identification) 	<p>Each satellite device in a Junos Fusion is identified by its FPC slot ID.</p> <p>To map an FPC slot ID to a satellite device's MAC address:</p> <ul style="list-style-type: none"> Satellite device in a cluster: <pre>set chassis satellite-management cluster sd-cluster-building1 fpc 101 system-id 00:00:5E:00:53:01</pre> <p>NOTE: You must map the FPC slot ID to the satellite device's MAC address when the satellite device is a member of a satellite device cluster.</p> Standalone satellite device: <pre>[edit] user@aggregation-device# set chassis satellite-management fpc 101 system-id 00:00:5E:00:53:01</pre> <p>To map an FPC slot ID to a satellite device's serial number:</p>	<p>FPC slot ID overview: "Understanding Junos Fusion Enterprise Components" on page 6</p> <p>Configuring FPC slot IDs:</p> <ul style="list-style-type: none"> "Configuring or Expanding a Junos Fusion Enterprise" on page 50 "system-id" on page 147 "serial-number" on page 144 "cascade-ports" on page 112 	

Table 11: Junos Fusion Enterprise Installation Checklist (*Continued*)

Task	Additional Information	For More Information	Performed by and Date
	<pre>set chassis satellite-management fpc 101 serial-number TA0123456789</pre> <p>To map an FPC slot ID to a cascade port:</p> <pre>set chassis satellite-management fpc 101 cascade-ports xe-0/0/1</pre>		
(Satellite device clusters only) Assign a member ID to each satellite device in a satellite device cluster.	<p>To assign a member ID to a satellite device in a satellite device cluster:</p> <pre>set chassis satellite-management cluster sd-cluster-building1 fpc 101 member-id 1</pre> <p>Satellite device cluster member ID configuration must match on both aggregation devices.</p>	<p>Satellite device clustering overview: "Understanding Satellite Device Clustering in a Junos Fusion" on page 15</p> <p>Satellite device cluster member ID configuration:</p> <ul style="list-style-type: none"> • "Configuring or Expanding a Junos Fusion Enterprise" on page 50 • "member-id" on page 131 	
Satellite Software Upgrade Group (Aggregation Devices)			
Acquire the satellite software image and place it on the aggregation devices (recommended) or on a remote server.	The satellite software image is used to install satellite software onto satellite devices.	Junos Fusion main software download page: Junos Fusion - Download Software	

Table 11: Junos Fusion Enterprise Installation Checklist (Continued)

Task	Additional Information	For More Information	Performed by and Date
<p>Manage the satellite software upgrade groups.</p> <ul style="list-style-type: none"> (satellite devices that are part of a satellite device cluster) associate the satellite devices in a cluster with a satellite software image. (standalone satellite devices) create the satellite software upgrade group and include the satellite device in it. 	<p>A satellite software upgrade group is used to upgrade the satellite software of all satellite devices in the upgrade group.</p> <p>A satellite device must be part of a satellite software upgrade group to install satellite software on satellite devices in most installation scenarios.</p> <p>All satellite devices in a satellite device cluster are automatically part of the same satellite software upgrade group. The satellite software upgrade group for the satellite devices in the cluster is automatically created and has the same name as the satellite device cluster.</p> <p>Satellite software upgrade group associations must match on both aggregation devices.</p> <ul style="list-style-type: none"> (satellite device cluster) To associate all satellite devices in the satellite device cluster with a satellite software image. For example: request system software add /var/tmp/ 	<p>Satellite software upgrade group overview: "Understanding Software in a Junos Fusion Enterprise" on page 25</p> <p>Satellite software upgrade group management:</p> <ul style="list-style-type: none"> "Managing Satellite Software Upgrade Groups in a Junos Fusion" on page 154 "satellite" on page 139 "Configuring or Expanding a Junos Fusion Enterprise" on page 50 "request system software add (Junos OS)" on page 205 	

Table 11: Junos Fusion Enterprise Installation Checklist (*Continued*)

Task	Additional Information	For More Information	Performed by and Date
	<p>satellite-3.0R1.2-signed.tgz upgrade-group sd-cluster-building1</p> <ul style="list-style-type: none"> (standalone satellite device) Create a satellite software upgrade group, and associate the satellite device with a satellite software image. For example: <pre>set chassis satellite-management upgrade-groups standalone-satdevs-building1 satellite 130-139</pre> <pre>request system software add /var/tmp/satellite-3.0R1.2-signed.tgz upgrade-group standalone-satdevs-building1</pre>		

Configuring the Second Aggregation Device (Dual Aggregation Device Topologies Only) (Aggregation Devices)

Table 11: Junos Fusion Enterprise Installation Checklist (Continued)

Task	Additional Information	For More Information	Performed by and Date
Delete single home configuration mode on both aggregation devices.	<p>To delete single home configuration mode on aggregation device 1:</p> <pre>delete chassis satellite-management single-home</pre> <p>Enter the same command on aggregation device 2:</p> <pre>delete chassis satellite-management single-home</pre>	<p>Dual aggregation device overview: "Understanding Junos Fusion Enterprise Components" on page 6</p> <p>Deleting single home configuration:</p> <ul style="list-style-type: none"> • "Configuring or Expanding a Junos Fusion Enterprise" on page 50 <p>"single-home" on page 146</p>	
Create and number the redundancy group on both aggregation devices.	<p>To create and number the redundancy group on aggregation device 1:</p> <pre>set chassis satellite-management redundancy-groups junos-fusion-campus-network redundancy-group-id 1</pre> <p>Enter the same command on aggregation device 2:</p> <pre>set chassis satellite-management redundancy-groups junos-fusion-campus-network redundancy-group-id 1</pre>	<p>Dual aggregation device overview: "Understanding Junos Fusion Enterprise Components" on page 6</p> <p>Dual aggregation device configuration: "Configuring or Expanding a Junos Fusion Enterprise" on page 50</p>	

Table 11: Junos Fusion Enterprise Installation Checklist (*Continued*)

Task	Additional Information	For More Information	Performed by and Date
Define the chassis ID number on each aggregation device.	<p>To define the chassis ID on aggregation device 1:set chassis satellite-management redundancy-groups chassis-id 1</p> <p>To define the chassis ID on aggregation device 2:set chassis satellite-management redundancy-groups chassis-id 2</p>	<p>Dual aggregation device overview: "Understanding Junos Fusion Enterprise Components" on page 6</p> <p>Dual aggregation device configuration: "Configuring or Expanding a Junos Fusion Enterprise" on page 50</p>	
Define the peer chassis ID number and ICL interface on each aggregation device.	<p>To define the peer chassis ID and ICL interface on aggregation device 1:</p> <p>set chassis satellite-management redundancy-groups junos-fusion-campus-network peer-chassis-id 2 inter-chassis-link xe-0/0/1</p> <p>To define the peer chassis ID and ICL interface on aggregation device 2:</p> <p>set chassis satellite-management redundancy-groups junos-fusion-campus-network peer-chassis-id 1 inter-chassis-link xe-0/0/1</p>	<p>Dual aggregation device overview: "Understanding Junos Fusion Enterprise Components" on page 6</p> <p>Dual aggregation device configuration: "Configuring or Expanding a Junos Fusion Enterprise" on page 50</p>	

Table 11: Junos Fusion Enterprise Installation Checklist (*Continued*)

Task	Additional Information	For More Information	Performed by and Date
<p>Add all satellite devices to the redundancy group on each aggregation device.</p>	<p>On aggregation device 1:</p> <pre>set chassis satellite-management redundancy-groups junos-fusion-campus-network satellite 130-131</pre> <pre>set chassis satellite-management redundancy-groups junos-fusion-campus-network cluster building-1</pre> <pre>set chassis satellite-management redundancy-groups junos-fusion-campus-network cluster building-2</pre> <p>Enter the same commands on aggregation device 2:</p> <pre>set chassis satellite-management redundancy-groups junos-fusion-campus-network satellite 130-131</pre> <pre>set chassis satellite-management redundancy-groups junos-fusion-campus-network cluster building-1</pre> <pre>set chassis satellite-management redundancy-groups junos-fusion-campus-network cluster building-2</pre>	<p>Dual aggregation device overview: "Understanding Junos Fusion Enterprise Components" on page 6</p> <p>Dual aggregation device configuration: "Configuring or Expanding a Junos Fusion Enterprise" on page 50</p>	

Table 11: Junos Fusion Enterprise Installation Checklist (*Continued*)

Task	Additional Information	For More Information	Performed by and Date
<p>Ensure ICCP is configured:</p> <ul style="list-style-type: none"> • Automatic ICCP provisioning. If you are not integrating your Junos Fusion Enterprise into an existing Enterprise or campus network, ICCP is automatically provisioned. No user action is required. • Manual ICCP configuration. If you are integrating your Junos Fusion Enterprise into an existing Enterprise or campus network, you may have to modify some ICCP setting to ensure the Junos Fusion Enterprise functions properly in your environment. 	<ul style="list-style-type: none"> • Automatic ICCP provisioning: No user action required. • Manual ICCP configuration. See Configuring Multichassis Link Aggregation on EX Series Switches. 	<p>ICCP overview: "Understanding ICCP in a Junos Fusion using Dual Aggregation Devices" on page 40</p> <p>Manual ICCP configuration:</p> <ul style="list-style-type: none"> • Configuring Multichassis Link Aggregation on EX Series Switches 	

Adding Satellite Devices (Aggregation Devices)

Table 11: Junos Fusion Enterprise Installation Checklist (*Continued*)

Task	Additional Information	For More Information	Performed by and Date
<p>Install satellite software onto a satellite device that is currently running Junos OS using one of the following methods:</p> <ul style="list-style-type: none"> • (Recommended) Autoconversion— Satellite software installed when satellite device cabled to aggregation device. • Manual conversion— Satellite software is installed when user enters CLI command to install satellite software. • Pre-installation— Satellite software is installed on satellite device before cabling it into the Junos Fusion. <p>A switch may have satellite software pre-installed because it was ordered</p>	<ul style="list-style-type: none"> • To enable autoconversion: <ul style="list-style-type: none"> <code>set chassis satellite-management auto-satellite-conversion satellite 101</code> • To manually convert a satellite device: <p>NOTE: This command is entered from an aggregation device.</p> <ul style="list-style-type: none"> <code>request chassis satellite interface xe-0/0/1 device-mode satellite</code> • To manually install satellite software onto a satellite device: <p>NOTE: This command is entered on the satellite device before it is configured into the Junos Fusion Enterprise. Please use the platform specific satellite software package appropriate for the platform as documented in <i>Understanding Platform-specific Satellite</i></p> 	<p>Satellite software installation methods overview:</p> <p>"Understanding Software in a Junos Fusion Enterprise" on page 25</p> <p>Installing satellite software:</p> <ul style="list-style-type: none"> • "Configuring or Expanding a Junos Fusion Enterprise" on page 50 • "satellite (Junos Fusion Automatic Satellite Conversion)" on page 136 • "request chassis satellite interface" on page 198 • "request chassis device-mode satellite" on page 186 	

Table 11: Junos Fusion Enterprise Installation Checklist (*Continued*)

Task	Additional Information	For More Information	Performed by and Date
from the factory running satellite software, it was previously part of a different Junos Fusion, or a user manually installed satellite software onto the switch.	<i>Software</i> in "Understanding Software in a Junos Fusion Enterprise" on page 25.		

RELATED DOCUMENTATION

[Junos Fusion Hardware and Software Compatibility Matrices](#)

[Understanding Junos Fusion Enterprise Software and Hardware Requirements | 29](#)

[Configuring or Expanding a Junos Fusion Enterprise | 50](#)

[Understanding Junos Fusion Enterprise Components | 6](#)

Adding a Switch Running Satellite Software to a Junos Fusion Enterprise

Use this procedure to add a switch that is already running satellite software to an operational Junos Fusion Enterprise as a satellite device.

NOTE: To add a switch running satellite software version 2.0 to a satellite device cluster of a Junos Fusion Enterprise system:

1. Convert the switch to Junos OS. See ["Installing Junos OS Software on a Standalone Device Running Satellite Software" on page 182.](#)

2. Switch to the Junos Fusion Enterprise system. See the section *Installing Satellite Software and Adding Satellite Devices to the Junos Fusion* in "[Configuring or Expanding a Junos Fusion Enterprise](#)" on page 50.

A switch could already be running satellite software because it was previously part of another Junos Fusion, or because a user manually installed the satellite software.

To add a switch running satellite software to a Junos Fusion Enterprise as a satellite device:

Before you begin:

- Ensure the version of satellite software on your switch is supported by the Junos Fusion Enterprise. See "[Understanding Junos Fusion Enterprise Software and Hardware Requirements](#)" on page 29.
- Ensure that a Junos Fusion Enterprise is configured and operational. For detailed information on setting up a Junos Fusion Enterprise, see "[Configuring or Expanding a Junos Fusion Enterprise](#)" on page 50.

1. Log into the aggregation device.
2. Configure the link on the aggregation device into a cascade port, if you have not done so already. For example, to configure interface xe-0/0/1 on the aggregation device into a cascade port:

```
[edit]
user@aggregation-device# set interfaces xe-0/0/1 cascade-port
```

3. Associate an FPC slot ID with the satellite device.

There are multiple methods of associating FPC slot IDs. See "[Configuring or Expanding a Junos Fusion Enterprise](#)" on page 50 for detailed information regarding FPC slot ID associations with satellite devices.

Examples:

- To associate FPC slot ID 101 with the satellite device that is connected to xe-0/0/1:

```
[edit]
user@aggregation-device# set chassis satellite-management fpc 101 cascade-ports xe-0/0/1
```

- To associate FPC slot ID 101 with the satellite device using the serial number ABCDEFGHIJKL:

```
[edit]
user@aggregation-device# set chassis satellite-management fpc 101 serial-number
ABCDEFGHIJKL
```

- To associate FPC slot ID 101 with the satellite device using MAC address 12:34:56:AB:CD:EF:

```
[edit]
user@aggregation-device# set chassis satellite-management fpc 101 system-id
12:34:56:AB:CD:EF
```

4. (Recommended) Configure the satellite switch into a satellite software upgrade group that uses the same version of satellite software that was manually installed onto the switch.

This step is advisable, but not always required. Completing this step ensures that the satellite software on your device is not upgraded to the version of satellite software associated with the satellite software upgrade group upon installation.

5. Commit the configuration to both Routing Engines:

```
[edit]
user@aggregation-device# commit synchronize
```

If you want to commit the configuration to a single Routing Engine:

```
[edit]
user@aggregation-device# commit
```

6. Cable the aggregation device to the satellite device using the assigned cascade port interface on the aggregation device that was assigned in Step 2.

Cascade port interface support is discussed in ["Understanding Junos Fusion Enterprise Software and Hardware Requirements" on page 29](#).

7. Power on the satellite device, if you have not already done so.

NOTE: The satellite device can be powered on at any point in this procedure.

RELATED DOCUMENTATION

[Configuring or Expanding a Junos Fusion Enterprise](#) | 50

[Understanding Junos Fusion Enterprise Software and Hardware Requirements](#) | 29

Enabling Configuration Synchronization Between Aggregation Devices in a Junos Fusion

A Junos Fusion using multiple aggregation devices often requires that the configuration of a feature—for example, an extended port, and entities such as routing instances and VLANs that include the extended port—must match on all aggregation devices. If a configuration statement for the feature—in this case, the extended port—is specified differently on one aggregation device, the statement on that aggregation device might be implemented in an unpredictable manner or might not be implemented at all.

Configuration synchronization can be used to ensure that configuration done in a configuration group is applied on all aggregation devices when committed. Configuration synchronization simplifies administration of a Junos Fusion by allowing users to enter configuration statements in a configuration group and apply the configuration group to all aggregation devices rather than repeating a configuration procedure manually on each aggregation device. Configuration synchronization also ensures configuration consistency in that the same configuration is applied to all aggregation devices.

We strongly recommend using configuration synchronization for software features that must be configured exactly the same on all aggregation devices.

The available group configuration options are beyond the scope of this document; see [Understanding MC-LAG Configuration Synchronization](#) and [Synchronizing and Committing MC-LAG Configurations](#) for additional information on using group configurations in an MC-LAG topology.

To enable configuration synchronization between aggregation devices in a Junos Fusion.

NOTE: For the sake of brevity, the examples in this procedure show the configuration on only two aggregation devices. Unless specifically called out, the examples for two aggregation devices also apply to topologies with four aggregation devices.

1. Ensure the aggregation devices are reachable from one another:

Aggregation device 1:

```
user@ad1> ping ad2 rapid
PING ad2.host.example.net (192.168.255.41): 56 data bytes
!!!!
```

```

mostly o--- ad2.example.net ping statistics ---
5 packets transmitted, 5 packets received, 0% packet loss
round-trip min/avg/max/stddev = 0.317/0.331/0.378/0.024 ms

```

Aggregation device 2:

```

user@ad2> ping ad1 rapid
PING ad1.host.example.net (192.168.255.40): 56 data bytes
!!!!
--- ad1.example.net ping statistics ---
5 packets transmitted, 5 packets received, 0% packet loss
round-trip min/avg/max/stddev = 0.317/0.331/0.378/0.024 ms

```

If the devices cannot ping one another, try statically mapping the hostnames of each device's management IP address and retry the ping.

Aggregation device 1:

```

user@ad1# set system static-host-mapping inet 192.168.255.41
user@ad1# commit
user@ad1# run ping ad2 rapid

```

Aggregation device 2:

```

user@ad2# set system static-host-mapping ad1 inet 192.168.255.40
user@ad2# commit
user@ad2# run ping ad1 rapid

```

If the devices cannot ping one another after the hostnames are statically mapped, see [Connecting and Configuring an EX9200 Switch \(CLI Procedure\)](#) or the [Installation and Upgrade Guide for EX9200 Switches](#).

2. Enable configuration synchronization:

Aggregation device 1:

```

user@ad1# set system commit peers-synchronize

```

Aggregation device 2:

```
user@ad2# set system commit peers-synchronize
```

3. Configure each aggregation device so that the other aggregation devices are identified as configuration peers. Enter the authentication credentials of each peer aggregation device to ensure group configurations on one aggregation device are committed to the other aggregation devices.

BEST PRACTICE: Configure a system master password to provide stronger encryption for configuration secrets using the `master-password` CLI statement. For more information on hardening shared secrets, see [Master Password for Configuration Encryption](#).



WARNING: The password `password` is used in this configuration step for illustrative purposes only. Use a more secure password in your device configuration.

NOTE: This step assumes a user with an authentication password has already been created on each Juniper Networks switch acting as an aggregation device. For instructions on configuring username and password combinations, see [Connecting and Configuring an EX9200 Switch \(CLI Procedure\)](#).

Aggregation device 1:

```
user@ad1# set system commit peers ad2 user root authentication password
```

Aggregation device 2:

```
user@ad2# set system commit peers ad1 user root authentication password
```

4. Enable the Network Configuration (NETCONF) protocol over SSH:

Aggregation device 1:

```
user@ad1# set system services netconf ssh
```

Aggregation device 2:

```
user@ad2# set system services netconf ssh
```

5. Commit the configuration:

Aggregation device 1:

```
user@ad1# commit
```

Aggregation device 2:

```
user@ad2# commit
```

6. (Optional) Create a configuration group for testing to ensure configuration synchronization is working.

Example for Junos Fusion Enterprise with aggregation devices that have one Routing Engine:

Aggregation Device 1:

```
user@ad1# set groups TEST when peers [ad1 ad2]
user@ad1# set apply-groups TEST
```

Aggregation Device 2:

```
user@ad2# set apply-groups TEST
```

7. (Optional) Configure and commit a group on aggregation device 1, and confirm it is implemented on aggregation device 2:

NOTE: This step shows how to change one interface configuration using groups. Interface ranges cannot be specified within groups and synchronized between configuration peers in a Junos Fusion to configure multiple interfaces simultaneously.

Aggregation device 1:

```
user@ad1# set groups TEST interfaces ge-0/0/1 description testing123
user@ad1# commit
```

Aggregation device 2:

```

user@ad2# show groups TEST
when {
  peers [ ad1 ad2 ];
}
interfaces {
  ge-0/0/1 {
    description testing123;
  }
}
user@ad2# run show interfaces ge-0/0/1
Physical interface: ge-0/0/1, Enabled, Physical link is Down
Interface index: 235, SNMP ifIndex: 743
Description: testing123
(additional output removed for brevity)

```

Perform the same procedure to verify configuration synchronization from aggregation device 2 to aggregation device 1, if desired.

Delete the test configuration group on each aggregation device.

Aggregation device 1:

```

user@ad1# delete groups test

```

Aggregation device 2:

```

user@ad2# delete groups test

```

See [Enabling Junos Fusion Enterprise on an Enterprise Campus Network](#) for a sample Junos Fusion Enterprise topology configured largely using configuration synchronization.

RELATED DOCUMENTATION

[Network Configuration Example: Configuring MC-LAG on EX9200 Switches in the Core for Campus Networks](#)

[Synchronizing and Committing MC-LAG Configurations](#)

[Understanding MC-LAG Configuration Synchronization](#)

[Understanding Configuration Synchronization in a Junos Fusion | 28](#)

Configuring Uplink Port Policies on a Junos Fusion

IN THIS SECTION

- [Configuring an Uplink Port Policy for a Standalone Satellite Device | 94](#)
- [Configuring an Uplink Port Policy for a Satellite Device Cluster | 95](#)

Ports on a satellite device that can be used as uplink ports are called candidate uplink ports. Each satellite device model has a set of default candidate uplink ports that the device can use to connect to the aggregation device and, in the case of a satellite device cluster, to other satellite devices. You can override the default set of candidate uplink and clustering ports by defining a candidate uplink port policy for the device.

To configure a candidate uplink port policy, you must first configure an uplink port group. The uplink port group defines a set of candidate uplink ports on a satellite device. Uplink port groups are assigned to candidate uplink port policies, which are assigned to satellite devices.

NOTE: The candidate uplink port policy must include at least one port from the default candidate uplink port. Otherwise, the aggregation device will not be able to communicate with the satellite device in order to provision the satellite device with the uplink port policy.

Configuring an Uplink Port Policy for a Standalone Satellite Device

To configure an uplink port policy:

1. Create an uplink port group:

```
[edit policy-options satellite-policies]  
user@switch# set port-group-alias port-group-alias-name
```

2. Configure the PICs that contain ports to be identified as candidate uplink ports:

```
[edit policy-options satellite-policies port-group-alias port-group-alias-name]
user@switch# set pic pic-number
```

3. Configure the ports on the PICs to be identified as candidate uplink ports:

```
[edit policy-options satellite-policies port-group-alias port-group-alias-name pic pic-number]
user@switch# set port [port-number | port-number-range | all]
```

4. Create a candidate uplink port policy:

```
[edit policy-options satellite-policies]
user@switch# set candidate-uplink-port-policy policy-name
```

5. Assign the uplink port group to the candidate uplink port policy:

```
[edit policy-options satellite-policies candidate-uplink-port-policy policy-name]
user@switch# set uplink-port-group group-name
```

Configuring an Uplink Port Policy for a Satellite Device Cluster

Candidate uplink port policies for a satellite device cluster can be applied at the cluster level, FPC level, or globally. Policies configured at the FPC-level take precedence over cluster and global policies. Policies configured at the cluster level take precedence over global policies.

1. Follow steps 1-3 in the procedure above to create an uplink port group.
2. Configure a candidate uplink port policy for a satellite cluster at the cluster level, FPC level, or global level:
 - To configure a policy at the cluster level:

```
[edit]
user@switch# set chassis satellite-management cluster cluster-name cluster-policy
satellite-port-policy-name
```

- To configure a policy at the FPC level:

```
[edit]
user@switch# set chassis satellite-management cluster cluster-name fpc fpc-number cluster-
policy satellite-port-policy-name
```

- To configure a policy at the global level:

```
[edit]
user@switch# set chassis satellite-management cluster-policy satellite-port-policy-name
```

3. Assign the uplink port group to the candidate uplink port policy:

```
[edit policy-options satellite-policies candidate-uplink-port-policy policy-name]
user@switch# set uplink-port-group group-name
```

RELATED DOCUMENTATION

| [Understanding Satellite Policies in a Junos Fusion](#) | 46

Configuring Satellite Device Alarm Handling Using an Environment Monitoring Satellite Policy in a Junos Fusion

This topic shows how to configure the alarm levels for link-down events on a satellite device in a Junos Fusion.

To configure system alarm handling in a Junos Fusion using an environment monitoring satellite policy:

1. Log in to the aggregation device.
2. Create and name the environment monitoring satellite policy:

```
[edit]
user@aggregation-device# set policy-options satellite-policies environment-monitoring-policy
policy-name
```

For example, to create an environment monitoring satellite policy named **linkdown-alarm-monitoring-1**:

```
[edit]
user@aggregation-device# set policy-options satellite-policies environment-monitoring-policy
linkdown-alarm-monitoring-1
```

3. Configure the link-down alarm behavior for the Junos Fusion using one or both of the following methods:

- Set the default link-down alarm to one setting whenever it is experienced in a Junos Fusion:

```
[edit policy-options satellite-policies environment-monitoring-policy policy-name]
user@aggregation-device# set alarm linkdown [ignore | red | yellow]
```

For example, to set the default link-down alarm to ignore for **linkdown-alarm-monitoring-1**:

```
[edit policy-options satellite-policies environment-monitoring-policy linkdown-alarm-
monitoring-1]
user@aggregation-device# set alarm linkdown ignore
```

- Set the link-down alarm behavior for a specific satellite device hardware model using terms:

```
[edit policy-options satellite-policies environment-monitoring-policy policy-name]
user@aggregation-device# set term term-name from product-model model-name alarm linkdown
[ignore | red | yellow]
```

where *term-name* is the user-defined name of the term, and *model-name* defines the product model of the satellite device that uses the satellite policy.

You can apply environment monitoring satellite policies individually or globally. You can, therefore, create multiple policies using the instructions in this step and apply them to different satellite devices in your Junos Fusion, when needed.

You can use multiple terms in the same environment monitoring satellite policy.

For example, if you wanted to configure EX4300 switches acting as satellite devices to send yellow alarms when link-down errors occur while QFX5100 switches acting as satellite devices send red alarms for the same condition:

```
[edit policy-options satellite-policies environment-monitoring-policy linkdown-alarm-monitoring-1]
user@aggregation-device# set term ex4300-yellow from product-model EX4300* alarm linkdown
yellow
user@aggregation-device# set term qfx5100-red from product-model QFX5100* alarm linkdown
red
```

4. Associate the environment monitoring satellite policy with a Junos Fusion configuration.

- To associate an environment monitoring satellite policy for all satellite devices in a Junos Fusion:

```
[edit chassis satellite-management]
user@aggregation-device# set environment-monitoring-policy policy-name
```

For example, to associate an environment monitoring satellite policy named **linkdown-alarm-monitoring-1** for all satellite devices in a Junos Fusion:

```
[edit chassis satellite-management]
user@aggregation-device# set environment-monitoring-policy linkdown-alarm-monitoring-1
```

- To associate an environment monitoring satellite policy for select FPC IDs in a Junos Fusion:

```
[edit chassis satellite-management fpc slot-id]
user@aggregation-device# set environment-monitoring-policy policy-name
```

For example, to associate an environment monitoring satellite policy named **linkdown-alarm-monitoring-1** for the satellite device associated with FPC ID 101 in a Junos Fusion:

```
[edit chassis satellite-management fpc 101]
user@aggregation-device# set environment-monitoring-policy linkdown-alarm-monitoring-1
```

You can configure a different environment monitoring policy for a single satellite device using the **fpc *slot-id*** when an environment monitoring policy for all satellite devices is configured. The environment monitoring policy for the FPC is enabled in cases when both an individual and global environment monitoring policy are configured.

5. Commit the configuration to both Routing Engines:

```
[edit]  
user@aggregation-device# commit synchronize
```

If you want to commit the configuration to the active Routing Engine only:

```
[edit]  
user@aggregation-device# commit
```

RELATED DOCUMENTATION

Configuring Junos Fusion Provider Edge

[Configuring or Expanding a Junos Fusion Enterprise](#)

Junos Fusion Enterprise Configuration Statements

IN THIS CHAPTER

- aging-timer (Junos Fusion) | 101
- alarm (Satellite Policies) | 102
- alias (Junos Fusion) | 104
- alias (Junos Fusion Satellite Device Clustering) | 106
- auto-satellite-conversion (Junos Fusion) | 107
- bgp-peer | 109
- cascade-port | 110
- cascade-ports | 112
- cascade-ports (Junos Fusion Satellite Device Cluster) | 114
- cluster (Junos Fusion) | 115
- cluster-id (Junos Fusion Satellite Device Cluster) | 117
- description (Junos Fusion) | 118
- description (Junos Fusion Satellite Device Cluster) | 120
- environment-monitoring-policy (satellite-management) | 121
- environment-monitoring-policy (satellite-policies) | 123
- fpc (Junos Fusion) | 125
- fpc (Junos Fusion Satellite Device Cluster) | 127
- linkdown (satellite-policies alarm) | 128
- mclag | 130
- member-id (Junos Fusion Satellite Device Cluster) | 131
- no-auto-iccp-provisioning (Junos Fusion Redundancy Group) | 133
- redundancy-group-id (Junos Fusion) | 134
- satellite (Junos Fusion Automatic Satellite Conversion) | 136
- satellite (Junos Fusion Satellite Device Homing) | 138
- satellite (Junos Fusion Satellite Software Upgrade Groups) | 139
- satellite-management (Junos Fusion) | 141

- [serial-number \(Junos Fusion\) | 144](#)
- [single-home \(Junos Fusion\) | 146](#)
- [system-id \(Junos Fusion\) | 147](#)
- [system-id \(Junos Fusion Satellite Device Cluster\) | 149](#)
- [upgrade-groups \(Junos Fusion\) | 151](#)

aging-timer (Junos Fusion)

IN THIS SECTION

- [Syntax | 101](#)
- [Hierarchy Level | 101](#)
- [Description | 101](#)
- [Default | 102](#)
- [Options | 102](#)
- [Required Privilege Level | 102](#)
- [Release Information | 102](#)

Syntax

```
aging-timer aging-timer;
```

Hierarchy Level

```
[edit chassis satellite-management]
```

Description

Configure the aging timer on the aggregation device in a Junos Fusion.

The aging timer is used on the aggregation device to specify the amount of time, in minutes, to maintain the device state of an unreachable satellite device before deleting the satellite device from the Junos Fusion.

If the unreachable satellite device is discovered before the aging timer expires, the satellite device is reactivated in the Junos Fusion without having to restore its device state.

Default

The default aging time is 10 minutes.

Options

The remaining statements are explained separately.

- **Range:** 2 through 60,000 minutes

Required Privilege Level

admin—To view this statement in the configuration.

admin-control—To add this statement to the configuration.

Release Information

Statement introduced in Junos OS Release 14.2R3.

RELATED DOCUMENTATION

[Configuring or Expanding a Junos Fusion Enterprise](#)

Configuring Junos Fusion Provider Edge

alarm (Satellite Policies)

IN THIS SECTION

● [Syntax | 103](#)

- Hierarchy Level | 103
- Description | 103
- Default | 103
- Options | 103
- Required Privilege Level | 103
- Release Information | 104

Syntax

```
alarm {  
    linkdown [ignore | red | yellow]  
}
```

Hierarchy Level

```
[edit policy-options satellite-policies environment-monitoring-policy policy-name]
```

Description

Configure the link down alarm that is sent within the Junos Fusion whenever a satellite device experiences a link-down error.

Default

Link-down alarms are not sent on satellite devices in a Junos Fusion until an environment monitoring policy is configured.

Options

The remaining statements are explained separately.

Required Privilege Level

admin—To view this statement in the configuration.

admin-control—To add this statement to the configuration.

Release Information

Statement introduced in Junos OS Release 14.2R3.

RELATED DOCUMENTATION

[Configuring Satellite Device Alarm Handling Using an Environment Monitoring Satellite Policy in a Junos Fusion | 96](#)

[Understanding Satellite Policies in a Junos Fusion | 46](#)

alias (Junos Fusion)

IN THIS SECTION

- [Syntax | 104](#)
- [Hierarchy Level | 104](#)
- [Description | 105](#)
- [Default | 105](#)
- [Options | 105](#)
- [Required Privilege Level | 105](#)
- [Release Information | 105](#)

Syntax

```
alias alias;
```

Hierarchy Level

```
[edit chassis satellite-management fpc slot-id]
```

Description

Configure an alias to label a satellite device.

Satellite device alias configuration is optional, but recommended. In a Junos Fusion, satellite device aliases assist with administration tasks, such as monitoring satellite devices using **show** command outputs, as well as with some configuration tasks that provide an option to identify a satellite device by its alias.

Default

Satellite devices are not assigned an alias, by default.

Options

alias The user-defined text name of the alias.

Required Privilege Level

admin—To view this statement in the configuration.

admin-control—To add this statement to the configuration.

Release Information

Statement introduced in Junos OS Release 14.2R3.

RELATED DOCUMENTATION

[Configuring or Expanding a Junos Fusion Enterprise](#)

Configuring Junos Fusion Provider Edge

alias (Junos Fusion Satellite Device Clustering)

IN THIS SECTION

- [Syntax | 106](#)
- [Hierarchy Level | 106](#)
- [Description | 106](#)
- [Default | 106](#)
- [Options | 107](#)
- [Required Privilege Level | 107](#)
- [Release Information | 107](#)

Syntax

```
alias alias;
```

Hierarchy Level

```
[edit chassis satellite-management cluster cluster-name fpc slot-id ]
```

Description

Configure an alias to label a satellite device in a satellite device cluster.

Satellite device alias configuration is optional, but recommended. In a Junos Fusion, satellite device aliases assist with administration tasks, such as monitoring satellite devices using **show** command outputs, as well as with some configuration tasks that provide an option to identify a satellite device by its alias.

Default

Satellite devices in a satellite device cluster are not assigned an alias, by default.

Options

alias The user-defined text name of the alias.

Required Privilege Level

admin—To view this statement in the configuration.

admin-control—To add this statement to the configuration.

Release Information

Statement introduced in Junos OS Release 16.1R1.

RELATED DOCUMENTATION

[Configuring or Expanding a Junos Fusion Enterprise | 50](#)

Configuring Junos Fusion Provider Edge

auto-satellite-conversion (Junos Fusion)

IN THIS SECTION

- [Syntax | 108](#)
- [Hierarchy Level | 108](#)
- [Description | 108](#)
- [Options | 108](#)
- [Required Privilege Level | 108](#)
- [Release Information | 108](#)

Syntax

```
auto-satellite-conversion {  
    satellite [slot-id | range | all];  
}
```

Hierarchy Level

```
[edit chassis satellite-management]
```

Description

Enable automatic satellite conversion in a Junos Fusion.

Automatic satellite conversion automatically configures a switch into a satellite device when it is cabled into the aggregation device.

Additional configuration steps are required to add satellite devices to a Junos Fusion using automatic satellite conversion. See *Configuring Junos Fusion Provider Edge* or [Configuring or Expanding a Junos Fusion Enterprise](#).

Options

The remaining statements are explained separately.

Required Privilege Level

admin—To view this statement in the configuration.

admin-control—To add this statement to the configuration.

Release Information

Statement introduced in Junos OS Release 14.2R3.

RELATED DOCUMENTATION

| [Configuring or Expanding a Junos Fusion Enterprise](#)

bgp-peer

IN THIS SECTION

- [Syntax | 109](#)
- [Hierarchy Level | 109](#)
- [Description | 109](#)
- [Options | 109](#)
- [Required Privilege Level | 110](#)
- [Release Information | 110](#)

Syntax

```
bgp-peer ip-address;
```

Hierarchy Level

```
[edit routing-instances name protocols evpn mclag]
```

Description

Configure an aggregation device in a Junos Fusion Enterprise or a multichassis link aggregation group (MC-LAG) topology to interwork with an Ethernet VPN-MPLS (EVPN-MPLS) device.

Options

ip-address IP address of the BGP peer. Typically, a BGP peer is identified by the IP address of the device's loopback interface.

Required Privilege Level

routing—To view this statement in the configuration.

routing-control—To add this statement to the configuration.

Release Information

Statement introduced in Junos OS Release 17.4R1.

RELATED DOCUMENTATION

Understanding EVPN-MPLS Interworking with Junos Fusion Enterprise and MC-LAG

cascade-port

IN THIS SECTION

- [Syntax | 110](#)
- [Hierarchy Level | 111](#)
- [Description | 111](#)
- [Default | 111](#)
- [Options | 111](#)
- [Required Privilege Level | 111](#)
- [Release Information | 111](#)

Syntax

```
cascade-port;
```

Hierarchy Level

```
[edit interfaces interface-name]
```

Description

Configure the specified interface on the aggregation device in a Junos Fusion into a cascade port.

Additional configuration is required to configure cascade ports on a Junos Fusion. See *Configuring Junos Fusion Provider Edge* or [Configuring or Expanding a Junos Fusion Enterprise](#).

Default

No interfaces are cascade ports, by default.

Options

interface-name Specifies the name of the interface.

Required Privilege Level

admin—To view this statement in the configuration.

admin-control—To add this statement to the configuration.

Release Information

Statement introduced in Junos OS Release 14.2R3.

RELATED DOCUMENTATION

[Configuring or Expanding a Junos Fusion Enterprise](#)

Configuring Junos Fusion Provider Edge

cascade-ports

IN THIS SECTION

- [Syntax | 112](#)
- [Hierarchy Level | 112](#)
- [Description | 112](#)
- [Default | 113](#)
- [Options | 113](#)
- [Required Privilege Level | 113](#)
- [Release Information | 113](#)

Syntax

```
cascade-ports interface-name;
```

Hierarchy Level

```
[edit chassis satellite-management fpc slot-id]
```

Description

Associate a cascade port with an FPC slot ID number in a Junos Fusion.

The FPC slot ID of the satellite device is determined by the value entered as the FPC *slot-id*. For instance, if the **set chassis satellite-management fpc 105 cascade-ports xe-0/0/1** statement is used to configure interface xe-0/0/1 into a cascade port, the satellite device that connects to interface xe-0/0/1 has an FPC slot ID of 105 in the Junos Fusion.

A Junos Fusion provides two methods of assigning an FPC identifier: Unique ID-based FPC identification and connectivity-based FPC identification. Unique ID-based FPC identification maps an FPC slot ID to a satellite device's MAC address or serial number, while connectivity-based FPC identification maps an FPC slot ID to a cascade port. This statement is used to assign an FPC ID using connectivity-based FPC identification by mapping an FPC slot ID to a cascade port.

In a Junos Fusion, each satellite device must be mapped to an FPC identifier (FPC ID). The FPC ID is used for Junos Fusion configuration, monitoring, and maintenance. Interface names—which are identified using the *type-fpc / pic / port* format—use the FPC ID as the *fpc* variable when the satellite device is participating in a Junos Fusion. For instance, built-in port 2—a Gigabit Ethernet interface on a satellite device that is using 101 as its FPC ID— uses *ge-101/0/2* as its interface name.

For additional information on the role of FPC slot IDs in a Junos Fusion, see *Understanding Junos Fusion Provider Edge Components* or [Understanding Junos Fusion Enterprise Components](#).

Default

No FPC slot IDs are associated with satellite devices, by default.

Options

interface-name Specifies the name of the interface.

Required Privilege Level

admin—To view this statement in the configuration.

admin-control—To add this statement to the configuration.

Release Information

Statement introduced in Junos OS Release 14.2R3.

RELATED DOCUMENTATION

[Configuring or Expanding a Junos Fusion Enterprise](#)

Configuring Junos Fusion Provider Edge

cascade-ports (Junos Fusion Satellite Device Cluster)

IN THIS SECTION

- [Syntax | 114](#)
- [Hierarchy Level | 114](#)
- [Description | 114](#)
- [Default | 114](#)
- [Options | 115](#)
- [Required Privilege Level | 115](#)
- [Release Information | 115](#)

Syntax

```
cascade-ports interface-name;
```

Hierarchy Level

```
[edit chassis satellite-management cluster cluster-name]
```

Description

Associate a cascade port with a satellite device cluster in a Junos Fusion.

This command defines which cascade ports are associated with a satellite device cluster only. An interface still needs to be converted into a cascade port before it performs cascade port functions. There are multiple ways to convert an interface on the aggregation device into a cascade port. See ["Configuring or Expanding a Junos Fusion Enterprise" on page 50](#).

Default

Cascade ports are not associated with satellite device clusters, by default.

Options

interface-name Specifies the name of the interface on the aggregation device that is associated with the satellite device cluster.

Required Privilege Level

admin—To view this statement in the configuration.

admin-control—To add this statement to the configuration.

Release Information

Statement introduced in Junos OS Release 16.1R1.

RELATED DOCUMENTATION

| [Configuring or Expanding a Junos Fusion Enterprise](#) | 50

cluster (Junos Fusion)

IN THIS SECTION

- [Syntax](#) | 116
- [Hierarchy Level](#) | 116
- [Description](#) | 116
- [Default](#) | 116
- [Options](#) | 116
- [Required Privilege Level](#) | 116
- [Release Information](#) | 117

Syntax

```

cluster cluster-name{
  cascade-ports interface-name;
  cluster-id cluster-id-number;
  fpc slot-id{
    alias alias;
    description description;
    member-id member-id-number;
    system-id mac-address;
  }
}

```

Hierarchy Level

[edit [chassis satellite-management](#)]

Description

Create and name a satellite device cluster.

Default

Satellite device clusters are not present, by default.

Options

cluster-name Specifies the name of the satellite device cluster.

The remaining statements are explained separately.

Required Privilege Level

admin—To view this statement in the configuration.

admin-control—To add this statement to the configuration.

Release Information

Statement introduced in Junos OS Release 16.1R1.

RELATED DOCUMENTATION

| [Configuring or Expanding a Junos Fusion Enterprise](#) | 50

cluster-id (Junos Fusion Satellite Device Cluster)

IN THIS SECTION

- [Syntax](#) | 117
- [Hierarchy Level](#) | 117
- [Description](#) | 117
- [Default](#) | 118
- [Options](#) | 118
- [Required Privilege Level](#) | 118
- [Release Information](#) | 118

Syntax

```
cluster-id cluster-id-number;
```

Hierarchy Level

```
[edit chassis satellite-management cluster cluster-name]
```

Description

Assign a cluster identification number to a satellite device cluster in a Junos Fusion.

The cluster identification number is used to identify a satellite device cluster in a Junos Fusion.

Default

Cluster identification numbers are not assigned in a Junos Fusion, by default.

Options

cluster-id-number Specifies the cluster identification number of the satellite device cluster in the Junos Fusion.

Required Privilege Level

admin—To view this statement in the configuration.

admin-control—To add this statement to the configuration.

Release Information

Statement introduced in Junos OS Release 16.1R1.

RELATED DOCUMENTATION

| [Configuring or Expanding a Junos Fusion Enterprise](#) | 50

description (Junos Fusion)

IN THIS SECTION

- [Syntax](#) | 119
- [Hierarchy Level](#) | 119
- [Description](#) | 119
- [Default](#) | 119
- [Options](#) | 119
- [Required Privilege Level](#) | 119

Syntax

```
description description;
```

Hierarchy Level

```
[edit chassis satellite-management fpc slot-id]
```

Description

Configure a description for the satellite device.

The description is optional and used for information purposes only.

Default

Satellite devices do not have descriptions, by default.

Options

description A text description of the satellite device.

Required Privilege Level

admin—To view this statement in the configuration.

admin-control—To add this statement to the configuration.

Release Information

Statement introduced in Junos OS Release 14.2R3.

RELATED DOCUMENTATION

[Configuring Junos Fusion Provider Edge](#)

[Configuring or Expanding a Junos Fusion Enterprise](#)

description (Junos Fusion Satellite Device Cluster)

IN THIS SECTION

- [Syntax | 120](#)
- [Hierarchy Level | 120](#)
- [Description | 120](#)
- [Default | 121](#)
- [Options | 121](#)
- [Required Privilege Level | 121](#)
- [Release Information | 121](#)

Syntax

```
description description;
```

Hierarchy Level

```
[edit chassis satellite-management cluster cluster-name fpc slot-id ]
```

Description

Configure a description for the satellite device in the satellite device cluster.

The description is optional and used for information purposes only.

Default

Satellite devices in satellite device clusters do not have descriptions, by default.

Options

description A text description of the satellite device in the satellite device cluster.

Required Privilege Level

admin—To view this statement in the configuration.

admin-control—To add this statement to the configuration.

Release Information

Statement introduced in Junos OS Release 16.1R1.

RELATED DOCUMENTATION

| [Configuring or Expanding a Junos Fusion Enterprise](#) | 50

environment-monitoring-policy (satellite-management)

IN THIS SECTION

- [Syntax](#) | 122
- [Hierarchy Level](#) | 122
- [Description](#) | 122
- [Default](#) | 122
- [Options](#) | 122
- [Required Privilege Level](#) | 123
- [Release Information](#) | 123

Syntax

```
environment-monitoring-policy policy-name;
```

Hierarchy Level

```
[edit chassis satellite-management]
[edit chassis satellite-management fpc slot-id]
```

Description

Enable an environment monitoring policy in a Junos Fusion.

You configure environment monitoring policies for a Junos Fusion in the [edit policy-options environment-monitoring-policy *policy-name*] hierarchy.

You can configure an environment monitoring policy in a Junos Fusion for a single satellite device using the **fpc *slot-id*** option, or for all satellite devices in the Junos Fusion by not specifying the **fpc *slot-id*** option.

You can configure a different environment monitoring policy for a single satellite device using the **fpc *slot-id*** when an environment monitoring policy for all satellite devices is configured. The environment monitoring policy for the FPC is enabled in cases when both an individual and global environment monitoring policy are configured.

Default

No environment monitoring policies for the Junos Fusion are present.

If you enable an environment monitoring policy in a Junos Fusion without specifying the **fpc *slot-id*** option, the environment monitoring policy is applied for all satellite devices in the Junos Fusion.

Options

policy-name Specifies the name of the environment monitoring policy.

The *policy-name* name is defined as part of the environment monitoring policy configuration procedure, which is handled in the [edit policy-options environment-monitoring-policy *policy-name*] hierarchy.

Required Privilege Level

admin—To view this statement in the configuration.

admin-control—To add this statement to the configuration.

Release Information

Statement introduced in Junos OS Release 14.2R3.

RELATED DOCUMENTATION

[Configuring Satellite Device Alarm Handling Using an Environment Monitoring Satellite Policy in a Junos Fusion | 96](#)

[Understanding Satellite Policies in a Junos Fusion | 46](#)

environment-monitoring-policy (satellite-policies)

IN THIS SECTION

- [Syntax | 123](#)
- [Hierarchy Level | 124](#)
- [Description | 124](#)
- [Options | 124](#)
- [Required Privilege Level | 124](#)
- [Release Information | 124](#)

Syntax

```
environment-monitoring-policy policy-name {  
  alarm {  
    linkdown [ignore | red | yellow]  
  }  
  term term-name{
```

```

    from {
        product-model model-name;
    }
}
}

```

Hierarchy Level

```
[edit policy-options satellite-policies]
```

Description

Configure an environment monitoring satellite policy for a device or devices in a Junos Fusion.

An environment monitoring satellite policy is used to configure alarm behavior on satellite devices in a Junos Fusion.

The environment monitoring policy is applied to a Junos Fusion using the [environment-monitoring-policy](#) statement in the [edit [chassis "satellite-management" on page 141](#)] or [edit [chassis "satellite-management" on page 141](#) ["fpc" on page 125](#) [slot-id](#)] hierarchy levels.

Options

policy-name Specifies the user-defined name of the environment monitoring policy.

The remaining statements are explained separately.

Required Privilege Level

admin—To view this statement in the configuration.

admin-control—To add this statement to the configuration.

Release Information

Statement introduced in Junos OS Release 14.2R3.

RELATED DOCUMENTATION

[Configuring Satellite Device Alarm Handling Using an Environment Monitoring Satellite Policy in a Junos Fusion | 96](#)

[Understanding Satellite Policies in a Junos Fusion | 46](#)

fpc (Junos Fusion)

IN THIS SECTION

- [Syntax | 125](#)
- [Hierarchy Level | 126](#)
- [Description | 126](#)
- [Options | 126](#)
- [Required Privilege Level | 126](#)
- [Release Information | 126](#)

Syntax

```
fpc slot-id{
  alias alias;
  cascade-ports interface-name;
  description description;
  environment-monitoring-policy policy;
  serial-number serial-number;
  system-id mac-address;
  uplink-failure-detection {
    candidate-uplink-policy policy;
  }
  local switching;
  selective-vlan-switching{
    routing-instance routing-instance;
  }
}
```

Hierarchy Level

[edit chassis satellite-management]

Description

Configure an FPC identifier for a satellite device within a Junos Fusion, or modify the configuration of an existing satellite device in a Junos Fusion.

Options

slot-id Specifies the FPC identifier of the device and functions as the FPC identifier in the interface name when configuring satellite device interfaces.

In a Junos Fusion Enterprise or Junos Fusion Provider Edge, the *slot-id* must have a value of 34 or greater.

NOTE: MPC10E and MPC11E are not supported in Junos Fusion, but can coexist with other MPC line cards in the MX router chassis that connect to satellite devices. When using MPC10E/MPC11E line cards in an MX series router that is supporting Junos Fusion, you must use a value range of 160 - 252 as the FPC identifier for the satellite device interfaces.

Junos Fusion does not support the hyper mode feature, so you must also use the `set forwarding-options no-hyper-mode` statement.

local switching Enables local-switching for all the ports on the satellite device.

The remaining statements are explained separately.

Required Privilege Level

admin—To view this statement in the configuration.

admin-control—To add this statement to the configuration.

Release Information

Statement introduced in Junos OS Release 14.2R3.

local-switching and selective-vlan-switching introduced in Junos OS Release 17.2R1 for Junos Fusion Provider Edge.

RELATED DOCUMENTATION

[Configuring Junos Fusion Provider Edge](#)

[Configuring or Expanding a Junos Fusion Enterprise](#)

fpc (Junos Fusion Satellite Device Cluster)

IN THIS SECTION

- [Syntax | 127](#)
- [Hierarchy Level | 127](#)
- [Description | 128](#)
- [Options | 128](#)
- [Required Privilege Level | 128](#)
- [Release Information | 128](#)

Syntax

```
fpc slot-id
  alias alias;
  description description;
  member-id member-id-number;
  system-id mac-address;
}
```

Hierarchy Level

```
[edit chassis satellite-management cluster cluster-name]
```

Description

Configure an FPC identifier for a satellite device in a satellite device cluster for a Junos Fusion, or modify the configuration of an existing satellite device in a satellite device cluster in a Junos Fusion.

Options

slot-id Specifies the FPC identifier of the device.

In a Junos Fusion, the *slot-id* must be 34 or larger, and functions as the FPC identifier in the interface name when configuring satellite device interfaces.

The remaining statements are explained separately.

Required Privilege Level

admin—To view this statement in the configuration.

admin-control—To add this statement to the configuration.

Release Information

Statement introduced in Junos OS Release 16.1R1.

RELATED DOCUMENTATION

[Configuring or Expanding a Junos Fusion Enterprise](#) | 50

linkdown (satellite-policies alarm)

IN THIS SECTION

- [Syntax](#) | 129
- [Hierarchy Level](#) | 129
- [Description](#) | 129
- [Options](#) | 129

- [Required Privilege Level | 129](#)
- [Release Information | 129](#)

Syntax

```
linkdown [ignore | red | yellow]
```

Hierarchy Level

```
[edit policy-options satellite-policies environment-monitoring-policy policy-name alarm]
```

Description

Configure the alarm behavior when an Ethernet link goes down on a satellite device in a Junos Fusion.

The configured alarm behavior can be applied to any satellite device in the Junos Fusion. The alarm behavior is applied to satellite devices using environment monitoring policies.

Options

- ignore** Do not signal an alarm when an Ethernet link-down event occurs.
- red** Raise a major alarm when an Ethernet link-down event occurs.
- yellow** Raise a minor alarm when an Ethernet link-down event occurs.

Required Privilege Level

admin—To view this statement in the configuration.

admin-control—To add this statement to the configuration.

Release Information

Statement introduced in Junos OS Release 14.2R3.

RELATED DOCUMENTATION

[Configuring Satellite Device Alarm Handling Using an Environment Monitoring Satellite Policy in a Junos Fusion | 96](#)

[Understanding Satellite Policies in a Junos Fusion | 46](#)

mclag

IN THIS SECTION

- [Syntax | 130](#)
- [Hierarchy Level | 130](#)
- [Description | 130](#)
- [Required Privilege Level | 131](#)
- [Release Information | 131](#)

Syntax

```
mclag {  
    bgp-peer ip-address;  
}
```

Hierarchy Level

```
[edit routing-instances name protocols evpn]
```

Description

Configure parameters that enable the interworking of Ethernet VPN-MPLS (EVPN-MPLS) with a Junos Fusion Enterprise or a multichassis link aggregation group (MC-LAG) topology.

The remaining statements are explained separately. See [CLI Explorer](#).

Required Privilege Level

routing—To view this statement in the configuration.

routing-control—To add this statement to the configuration.

Release Information

Statement introduced in Junos OS Release 17.4R1.

RELATED DOCUMENTATION

Understanding EVPN-MPLS Interworking with Junos Fusion Enterprise and MC-LAG

member-id (Junos Fusion Satellite Device Cluster)

IN THIS SECTION

- [Syntax | 131](#)
- [Hierarchy Level | 132](#)
- [Description | 132](#)
- [Default | 132](#)
- [Options | 132](#)
- [Required Privilege Level | 132](#)
- [Release Information | 132](#)

Syntax

```
member-id member-ID-number;
```

Hierarchy Level

```
[edit chassis satellite-management cluster cluster-name fpc slot-id ]
```

Description

Assign a member ID number to a satellite device in a satellite device cluster.

The member ID is used to identify the satellite device within the satellite device cluster.

Default

Member ID numbers are not assigned in a satellite device cluster, by default.

Options

member-ID-number Specifies the member ID of the satellite device in the satellite device cluster.

Required Privilege Level

admin—To view this statement in the configuration.

admin-control—To add this statement to the configuration.

Release Information

Statement introduced in Junos OS Release 16.1R1.

RELATED DOCUMENTATION

| [Configuring or Expanding a Junos Fusion Enterprise](#) | 50

no-auto-iccp-provisioning (Junos Fusion Redundancy Group)

IN THIS SECTION

- [Syntax | 133](#)
- [Hierarchy Level | 133](#)
- [Description | 133](#)
- [Default | 134](#)
- [Required Privilege Level | 134](#)
- [Release Information | 134](#)

Syntax

```
no-auto-iccp-provisioning;
```

Hierarchy Level

```
[edit chassis satellite-management redundancy-groups redundancy-group-name peer-chassis-id peer-chassis-id-number]
```

Description

Disable automatic ICCP provisioning of an interchassis link (ICL) for the redundancy group used to configure dual aggregation devices in a Junos Fusion topology.

Automatic ICCP provisioning of an interchassis link (ICL) simplifies configuration of a Junos Fusion with dual aggregation devices by automatically provisioning the ICCP configuration within the Junos Fusion, instead of requiring the user to manually configure all ICCP parameters. Automatic ICCP Provisioning of an interchassis link (ICL) is enabled by default for a Junos Fusion using a dual aggregation device topology; this statement disables automatic ICCP provisioning.

If this statement is entered, the user has to manually configure ICCP in the redundancy group used to configure dual aggregation devices in a Junos Fusion topology.

This statement is optional. You can manually configure any available ICCP configuration parameters in the redundancy group when automatic ICCP provisioning is enabled. In cases where a user configures an ICCP parameter when automatic ICCP provisioning is enabled, the user-configured ICCP configuration is used over the automatically-provisioned ICCP configuration parameter.

User configuration of ICCP in a Junos Fusion is not required. This statement is recommended for use by expert users only.

Default

Automatic ICCP Provisioning is enabled by default in redundancy groups used to configure dual aggregation devices in a Junos Fusion topology.

Required Privilege Level

admin—To view this statement in the configuration.

admin-control—To add this statement to the configuration.

Release Information

Statement introduced in Junos OS Release 16.1R1.

RELATED DOCUMENTATION

| [Configuring or Expanding a Junos Fusion Enterprise](#) | 50

redundancy-group-id (Junos Fusion)

IN THIS SECTION

- [Syntax](#) | 135
- [Hierarchy Level](#) | 135
- [Description](#) | 135
- [Default](#) | 135
- [Options](#) | 135

- Required Privilege Level | 135
- Release Information | 136

Syntax

```
redundancy-group-id redundancy-group-id-number;
```

Hierarchy Level

```
[edit chassis satellite-management redundancy-groups redundancy-group-name]
```

Description

Defines a redundancy group ID number for a redundancy group in a Junos Fusion using dual aggregation devices.

A Junos Fusion using dual aggregation devices must have one redundancy group that includes both aggregation devices and all satellite devices. The redundancy group must be configured individually on each aggregation device. The redundancy group name and redundancy group ID number must match on the redundancy group configuration on each aggregation device in the Junos Fusion.

Default

A redundancy group does not have a redundancy group ID number by default.

Options

redundancy-group-id-number The user-defined redundancy group ID number.

- **Range:** 1 through 255

Required Privilege Level

admin—To view this statement in the configuration.

admin-control—To add this statement to the configuration.

Release Information

Statement introduced in Junos OS Release 16.1R1.

RELATED DOCUMENTATION

| [Configuring or Expanding a Junos Fusion Enterprise](#) | 50

satellite (Junos Fusion Automatic Satellite Conversion)

IN THIS SECTION

- [Syntax](#) | 136
- [Hierarchy Level](#) | 136
- [Description](#) | 136
- [Options](#) | 137
- [Required Privilege Level](#) | 137
- [Release Information](#) | 137

Syntax

```
satellite [slot-id | range | all];
```

Hierarchy Level

```
[edit chassis satellite-management auto-satellite-conversion]
```

Description

Specify the interface to enable automatic software conversion in a Junos Fusion.

The device that is cabled to the slot specified in this command is automatically converted into a satellite device.

Additional configuration steps are required to add satellite devices to a Junos Fusion using automatic satellite conversion. See [Configuring or Expanding a Junos Fusion Enterprise](#) or *Configuring Junos Fusion Provider Edge*.

Options

slot-id Specifies the FPC slot identifier of the device that will be automatically converted into a satellite device.

The FPC identifier must be mapped to a cascade port interface before this command is operational. See [Configuring or Expanding a Junos Fusion Enterprise](#) or *Configuring Junos Fusion Provider Edge*.

range Specifies a range of FPC slot identifiers that will automatically be converted into satellite devices. For instance, to specify that FPC IDs 103, 104, and 105 should be automatically converted into satellite devices, enter a *range* of **103-105**.

all Specifies that all FPC slot identifiers in the Junos Fusion will automatically be converted into satellite devices.

Required Privilege Level

admin—To view this statement in the configuration.

admin-control—To add this statement to the configuration.

Release Information

Statement introduced in Junos OS Release 14.2R3.

RELATED DOCUMENTATION

Configuring Junos Fusion Provider Edge

[Configuring or Expanding a Junos Fusion Enterprise](#)

satellite (Junos Fusion Satellite Device Homing)

IN THIS SECTION

- [Syntax | 138](#)
- [Hierarchy Level | 138](#)
- [Description | 138](#)
- [Options | 138](#)
- [Required Privilege Level | 139](#)
- [Release Information | 139](#)

Syntax

```
satellite [slot-id | slot-id-range | all];
```

Hierarchy Level

```
[edit chassis satellite-management single-home]
```

Description

Specify which satellite device links are single-homed to the aggregation device.

You must enter this statement to configure a Junos Fusion when the aggregation device is running Junos OS Release 14.2R3 or 14.2R4. You are not required to enter this command when the aggregation device is running Junos OS Release 14.2R5 or later.

Options

slot-id Specifies that a link from a specified satellite device is single-homed to the aggregation device. The *slot-id* is the satellite device member number.

- slot-id-range*** Specifies that the links from a range of specified satellite devices are single-homed to the aggregation device. The *slot-id-range* includes the satellite device member numbers.
- all** Specifies that all links from satellite devices are single-homed to the aggregation device.

Required Privilege Level

admin—To view this statement in the configuration.

admin-control—To add this statement to the configuration.

Release Information

Statement introduced in Junos OS Release 14.2R3.

Statement introduced in Junos OS Release 16.1R1 for Junos Fusion Enterprise.

RELATED DOCUMENTATION

Configuring Junos Fusion Provider Edge

[Configuring or Expanding a Junos Fusion Enterprise | 50](#)

satellite (Junos Fusion Satellite Software Upgrade Groups)

IN THIS SECTION

- [Syntax | 140](#)
- [Hierarchy Level | 140](#)
- [Description | 140](#)
- [Options | 140](#)
- [Required Privilege Level | 140](#)
- [Release Information | 140](#)

Syntax

```
satellite [slot-id | range | all];
```

Hierarchy Level

```
[edit chassis satellite-management upgrade-groups upgrade-group-name]
```

Description

Specify the satellite device to add to the satellite software upgrade group.

This statement is entered on an aggregation device in a Junos Fusion. Software upgrade groups are configured and managed using the aggregation device.

Options

slot-id Specifies the FPC slot identification number of the satellite device that is being added to the satellite software upgrade group.

range Specifies a range of FPC slot identifiers to add to the satellite software upgrade group. For instance, to specify that FPC IDs 103, 104, and 105 should be automatically converted into satellite devices, enter a *range* of **103-105**.

all Specifies that all FPC slot identifiers in the Junos Fusion are added to the satellite software upgrade group.

The remaining statements are explained separately.

Required Privilege Level

admin—To view this statement in the configuration.

admin-control—To add this statement to the configuration.

Release Information

Statement introduced in Junos OS Release 14.2R3.

RELATED DOCUMENTATION

[Configuring Junos Fusion Provider Edge](#)

[Configuring or Expanding a Junos Fusion Enterprise](#)

satellite-management (Junos Fusion)

IN THIS SECTION

- [Syntax | 141](#)
- [Hierarchy Level | 143](#)
- [Description | 143](#)
- [Options | 143](#)
- [Required Privilege Level | 143](#)
- [Release Information | 143](#)

Syntax

```
satellite-management {
  aging-timer aging-timer;
  auto-satellite-conversion {
    satellite [slot-id | range | all];
  }
  cluster cluster-name{
    cascade-ports interface-name;
    cluster-id cluster-id-number;
    fpc slot-id{
      alias alias;
      description description;
      member-id member-id-number;
      system-id mac-address;
    }
  }
  environment-monitoring-policy policy;
  firewall
```



```

family family-name {
    filter filter-name {
        term term-name {
            from {
                match-conditions;
            }
            then {
                action;
                action-modifiers;
            }
        }
    }
}

fpc slot-id {
    alias alias;
    cascade-ports interface-name;
    description description;
    environment-monitoring-policy policy;
    serial-number serial-number;
    system-id mac-address;
    uplink-failure-detection {
        candidate-uplink-policy policy;
    }
}

psu {
    redundancy {
        n-plus-n;
    }
}

redundancy-groups {
    chassis-id number;
    redundancy-group-name {
        redundancy-group-id redundancy-group-id-number;
        peer-chassis-id peer-chassis-id-number {
            inter-chassis-link interface-name;
            no-auto-iccp-provisioning;
            satellite satellite-device-fpc-IDs;
        }
    }
}

single-home {
    satellite [slot-id | slot-id-range | all];
}

```

```

upgrade-groups upgrade-group-name {
    satellite [slot-id | range | all];
}
uplink-failure-detection {
    candidate-uplink-policy policy;
}
}

```

Hierarchy Level

[edit [chassis](#)]

Description

Configure and manage a Junos Fusion.

If you enter the **delete chassis satellite-management** command to delete a Junos Fusion configuration, we recommend also rebooting the Routing Engines on your device to maximize device performance.

Options

The remaining statements are explained separately.

Required Privilege Level

admin—To view this statement in the configuration.

admin-control—To add this statement to the configuration.

Release Information

Statement introduced in Junos OS Release 14.2R3.

RELATED DOCUMENTATION

[Configuring or Expanding a Junos Fusion Enterprise](#)

Configuring Junos Fusion Provider Edge

serial-number (Junos Fusion)

IN THIS SECTION

- [Syntax | 144](#)
- [Hierarchy Level | 144](#)
- [Description | 144](#)
- [Default | 145](#)
- [Options | 145](#)
- [Required Privilege Level | 145](#)
- [Release Information | 145](#)

Syntax

```
serial-number serial-number;
```

Hierarchy Level

```
[edit chassis satellite-management fpc slot-id]
```

Description

Bind the specified FPC slot ID to a satellite device based on the serial number.

A Junos Fusion provides two methods of assigning an FPC identifier: Unique ID-based FPC identification and connectivity-based FPC identification. Unique ID-based FPC identification maps an FPC slot ID to a satellite device's MAC address or serial number, while unique ID-based FPC identification maps an FPC slot ID to a cascade port. This statement is used to assign an FPC ID using unique ID-based FPC identification by mapping the FPC slot ID to the satellite device's serial number.

In a Junos Fusion, each satellite device must be mapped to an FPC identifier (FPC ID). The FPC ID is used for Junos Fusion configuration, monitoring, and maintenance. Interface names—which are identified using the *type-fpc / pic / port* format—use the FPC ID as the *fpc* variable when the satellite

device is participating in a Junos Fusion. For instance, built-in port 2—a Gigabit Ethernet interface on a satellite device that is using 101 as its FPC ID—uses ge-101/0/2 as its interface name.

For additional information on the role of FPC slot IDs in a Junos Fusion, see [Understanding Junos Fusion Enterprise Components](#) or *Understanding Junos Fusion Provider Edge Components*.

If the serial number that is configured using this statement does not match the serial number of the satellite device, the device is not converted into a satellite device.

Default

No FPC slot IDs are associated with satellite devices, by default.

Options

serial-number Specifies the serial number of the satellite device.

Required Privilege Level

admin—To view this statement in the configuration.

admin-control—To add this statement to the configuration.

Release Information

Statement introduced in Junos OS Release 14.2R3.

Statement introduced in Junos OS Release 16.1R1 for Junos Fusion Enterprise.

RELATED DOCUMENTATION

Configuring Junos Fusion Provider Edge

[Configuring or Expanding a Junos Fusion Enterprise](#)

single-home (Junos Fusion)

IN THIS SECTION

- [Syntax | 146](#)
- [Hierarchy Level | 146](#)
- [Description | 146](#)
- [Options | 146](#)
- [Required Privilege Level | 146](#)
- [Release Information | 147](#)

Syntax

```
single-home {  
    satellite [slot-id | slot-id-range | all];  
}
```

Hierarchy Level

```
[edit chassis satellite-management]
```

Description

Specify that the links connecting the satellite device to the aggregation device are connected to the aggregation device only.

Options

The remaining statements are explained separately.

Required Privilege Level

admin—To view this statement in the configuration.

admin-control—To add this statement to the configuration.

Release Information

Statement introduced in Junos OS Release 14.2R3.

Statement introduced in Junos OS Release 16.1R1 for Junos Fusion Enterprise.

RELATED DOCUMENTATION

[Configuring Junos Fusion Provider Edge](#)

[Configuring or Expanding a Junos Fusion Enterprise](#)

system-id (Junos Fusion)

IN THIS SECTION

- [Syntax | 147](#)
- [Hierarchy Level | 148](#)
- [Description | 148](#)
- [Default | 148](#)
- [Options | 148](#)
- [Required Privilege Level | 149](#)
- [Release Information | 149](#)

Syntax

```
system-id mac-address;
```

Hierarchy Level

```
[edit chassis satellite-management fpc slot-id]
```

Description

Assign the specified FPC identifier to the satellite device based on the satellite device's MAC address.

For instance, if you wanted the satellite device using MAC address **01:02:03:AA:BB:CC** to be assigned FPC identifier 101, enter the **set chassis satellite-management fpc 101 system-id 01:02:03:AA:BB:CC** statement.

A Junos Fusion provides two methods of assigning an FPC identifier: Unique ID-based FPC identification and connectivity-based FPC identification. Unique ID-based FPC identification maps an FPC slot ID to a satellite device's MAC address or serial number, while connectivity-based FPC identification maps an FPC slot ID to a cascade port. This statement is used to assign an FPC ID using unique ID-based FPC identification by mapping the FPC slot ID to the satellite device's MAC address.

In a Junos Fusion, each satellite device must be mapped to an FPC identifier (FPC ID). The FPC ID is used for Junos Fusion configuration, monitoring, and maintenance. Interface names—which are identified using the *type-fpc / pic / port* format—use the FPC ID as the *fpc* variable when the satellite device is participating in a Junos Fusion. For instance, built-in port 2—a gigabit Ethernet interface on a satellite device that is using 101 as its FPC ID—uses ge-101/0/2 as its interface name.

For additional information on the role of FPC slot IDs in a Junos Fusion, see *Understanding Junos Fusion Provider Edge Components* or [Understanding Junos Fusion Enterprise Components](#).

If the serial number that is configured using this statement does not match the serial number of the satellite device, the device is not converted into a satellite device.

If the MAC address that is configured using this statement does not match the MAC address of the satellite device, the device is not converted into a satellite device.

Default

No FPC slot IDs are associated with satellite devices, by default.

Options

mac-address Specifies the MAC address of the satellite device.

Required Privilege Level

admin—To view this statement in the configuration.

admin-control—To add this statement to the configuration.

Release Information

Statement introduced in Junos OS Release 14.2R3.

RELATED DOCUMENTATION

Configuring Junos Fusion Provider Edge

[Configuring or Expanding a Junos Fusion Enterprise](#)

system-id (Junos Fusion Satellite Device Cluster)

IN THIS SECTION

- [Syntax | 149](#)
- [Hierarchy Level | 150](#)
- [Description | 150](#)
- [Default | 150](#)
- [Options | 150](#)
- [Required Privilege Level | 150](#)
- [Release Information | 150](#)

Syntax

```
system-id mac-address;
```

Hierarchy Level

```
[edit chassis satellite-management cluster cluster-name fpc slot-id ]
```

Description

Assign the specified FPC identifier to the satellite device in the satellite device cluster based on the satellite device's MAC address.

For instance, if you wanted the satellite device using MAC address **01:02:03:AA:BB:CC** in the satellite device cluster named *building-1* to be assigned FPC identifier 101, enter the **set chassis satellite-management cluster *building-1* fpc 101 system-id 01:02:03:AA:BB:CC** statement.

If the MAC address that is configured using this statement does not match the MAC address of the satellite device, the device is not converted into a satellite device.

Default

No FPC slot ID numbers are associated with satellite devices, by default.

Options

mac-address Specifies the MAC address of the satellite device.

Required Privilege Level

admin—To view this statement in the configuration.

admin-control—To add this statement to the configuration.

Release Information

Statement introduced in Junos OS Release 16.1R1.

RELATED DOCUMENTATION

| [Configuring or Expanding a Junos Fusion Enterprise](#) | 50

upgrade-groups (Junos Fusion)

IN THIS SECTION

- [Syntax | 151](#)
- [Hierarchy Level | 151](#)
- [Description | 151](#)
- [Default | 152](#)
- [Options | 152](#)
- [Required Privilege Level | 152](#)
- [Release Information | 152](#)

Syntax

```
upgrade-groups upgrade-group-name {  
    satellite [slot-id | range | all];  
}
```

Hierarchy Level

```
[edit chassis satellite-management]
```

Description

Create and name a satellite software upgrade group for a Junos Fusion, or specify an existing satellite software upgrade group to configure.

A satellite software upgrade group is a group of satellite devices that are designated to upgrade to the same satellite software version using the same satellite software package. One Junos Fusion can contain multiple software upgrade groups, and multiple software upgrade groups should be configured in most Junos Fusions to avoid network downtimes during satellite software installations.

The two most common methods of installing satellite software in a Junos Fusion—autoconverting a device into a satellite device when it is cabled into an aggregation device and manually converting a

device that is cabled into an aggregation device into a satellite device—require a configured satellite software upgrade group.

Software upgrade groups are configured and managed from the aggregation device.

To associate a satellite software package with a satellite software upgrade group, use the **request system software add** *package-name* **upgrade-group** *upgrade-group-name* command.

This statement is entered on an aggregation device in a Junos Fusion. Software upgrade groups are configured and managed from the aggregation device.

The software upgrade group configurations must match exactly—including the same *package-name* and *upgrade-group-name*—in every Junos Fusion with dual aggregation devices to avoid satellite device downtime.

All satellite devices in a satellite device cluster are associated with a single satellite software upgrade group, which is automatically created when a satellite device cluster becomes part of a Junos Fusion. The satellite software upgrade group is named after the satellite device cluster name, and ensures that all satellite devices in the cluster run the same version of satellite software. See [Understanding Software in a Junos Fusion Enterprise](#) for additional information on software management for a satellite device cluster.

Default

No satellite software upgrade groups are present, by default.

A satellite software upgrade group with the name of the satellite device cluster is created automatically when a satellite device cluster is created.

Options

upgrade-group-name Specifies the user-defined name for the satellite software upgrade group.

The remaining statements are explained separately.

Required Privilege Level

admin—To view this statement in the configuration.

admin-control—To add this statement to the configuration.

Release Information

Statement introduced in Junos OS Release 14.2R3.

Statement introduced in Junos OS Release 16.1R1 for Junos Fusion Enterprise.

RELATED DOCUMENTATION

[Configuring or Expanding a Junos Fusion Enterprise](#)

Configuring Junos Fusion Provider Edge

Junos Fusion Enterprise Administration

IN THIS CHAPTER

- [Managing Satellite Software Upgrade Groups in a Junos Fusion | 154](#)
- [Upgrading Junos OS and Satellite Software in an Operational Junos Fusion Enterprise with Dual Aggregation Devices | 159](#)
- [Verifying Connectivity, Device States, Satellite Software Versions, and Operations in a Junos Fusion | 161](#)
- [Converting a Satellite Device in a Junos Fusion to a Standalone Device | 178](#)
- [Installing Junos OS Software on a Standalone Device Running Satellite Software | 182](#)

Managing Satellite Software Upgrade Groups in a Junos Fusion

IN THIS SECTION

- [Creating a Satellite Software Upgrade Group | 155](#)
- [Adding Satellite Devices to a Satellite Software Upgrade Group | 155](#)
- [Removing a Satellite Device from a Satellite Software Upgrade Group | 156](#)
- [Modifying the Satellite Software Used by a Satellite Software Upgrade Group | 157](#)
- [Deleting Associated Satellite Software from a Satellite Software Upgrade Group | 158](#)
- [Deleting Satellite Software on the Aggregation Device | 159](#)

This topic discusses maintaining satellite software upgrade groups in a Junos Fusion. For more information on the process for creating a satellite software upgrade group, see *Configuring Junos Fusion Provider Edge* or [Configuring or Expanding a Junos Fusion Enterprise](#).

A satellite software upgrade group is a group of satellite devices that are designated to upgrade to the same satellite software version using the same satellite software package. One Junos Fusion can contain

multiple software upgrade groups, and multiple software upgrade groups should be configured in most Junos Fusions to avoid network downtimes during satellite software installations.

When a satellite device is added to a Junos Fusion, the aggregation device checks if the satellite device is using an FPC ID that is included in a satellite software upgrade group. If the satellite device is using an FPC ID that is part of a satellite software upgrade group, the device upgrades its satellite software to the version of software associated with the satellite software upgrade group - unless it is already running the defined version.

When the satellite software package associated with an existing satellite software group is changed, the satellite software for all member satellite devices is upgraded using a throttled upgrade. The throttled upgrade ensures that the aggregation device is not overwhelmed with providing satellite software simultaneously to many satellite devices.

The two most common methods of installing satellite software—autoconverting a device into a satellite device when it is cabled into an aggregation device and manually converting a device that is cabled into an aggregation device into a satellite device—require a configured satellite software upgrade group.

Software upgrade groups are configured and managed from the aggregation device. All satellite devices in a satellite device cluster are part of the same software upgrade group, and a software upgrade group with the name of the satellite device cluster is automatically created when the satellite device cluster is created.

Creating a Satellite Software Upgrade Group

If your satellite device is a member of a satellite device cluster, a satellite software upgrade group with the name of the satellite device cluster is automatically created when the satellite device cluster is created. This satellite software upgrade group must be used to manage the satellite software for all member satellite devices in the satellite device cluster.

For information on creating a satellite software upgrade group for a satellite device that is not part of a satellite device cluster, see *Configuring Junos Fusion Provider Edge* or [Configuring or Expanding a Junos Fusion Enterprise](#).

Adding Satellite Devices to a Satellite Software Upgrade Group

To add a satellite device to an existing satellite software upgrade group, enter the `set chassis satellite-management upgrade-groups upgrade-group-name satellite slot-id-or-range` command:

```
[edit]
user@aggregation-device# set chassis satellite-management upgrade-groups upgrade-group-name
satellite slot-id-or-range
```

where *upgrade-group-name* is the name of the existing satellite software upgrade group, and the *slot-id-or-range* is the FPC slot ID or range of FPC slot IDs of the satellite devices that are being added to the upgrade group.

For example, to add FPC slot IDs 121, 122, and 123 to a satellite software upgrade group named **group1**:

```
[edit]
user@aggregation-device# set chassis satellite-management upgrade-groups group1 satellite 121-123
```

Additionally, you can use the **all** statement as your *slot-id-or-range* to include all satellite devices in the Junos Fusion in the satellite software upgrade group.

For example, to add all satellite devices in the Junos Fusion to a satellite software upgrade group named **group1**:

```
[edit]
user@aggregation-device# set chassis satellite-management upgrade-groups group1 satellite all
```

Removing a Satellite Device from a Satellite Software Upgrade Group

To remove a satellite device from an existing satellite software upgrade group, enter the `delete chassis satellite-management upgrade-groups upgrade-group-name satellite slot-id-or-range` statement to delete the statements that initially added the member satellite devices to the satellite software upgrade group.

```
[edit]
user@aggregation-device# delete chassis satellite-management upgrade-groups upgrade-group-name
satellite slot-id-or-range
```

where *upgrade-group-name* is the name of the existing satellite software upgrade group, and the *slot-id-or-range* is the FPC slot ID or range of FPC slot IDs of the satellite devices that are being added to the upgrade group.

In cases where you want to remove some FPC slot IDs that were configured within a range of FPC slot IDs, you might consider re-creating the satellite software group by first deleting it, then re-creating it. To delete the satellite software upgrade group:

```
[edit]
user@aggregation-device# delete chassis satellite-management upgrade-groups upgrade-group-name
```

You can then re-create the satellite software upgrade group and add satellite devices using the `set chassis satellite-management upgrade-groups upgrade-group-name satellite slot-id-or-range` statement:

```
[edit]
user@aggregation-device# set chassis satellite-management upgrade-groups upgrade-group-name
satellite slot-id-or-range
```

For more information on the satellite software upgrade group creation process, see *Configuring Junos Fusion Provider Edge* or [Configuring or Expanding a Junos Fusion Enterprise](#).

Modifying the Satellite Software Used by a Satellite Software Upgrade Group

Before you begin:

- Ensure that a satellite software package is downloaded to the location where you will use it to install the satellite software.

```
user@aggregation-device> request system software add package-name upgrade-group upgrade-group-name
```

NOTE: A satellite software *upgrade-group-name* can be a user-configured upgrade group or the name of a satellite device cluster.

To associate a satellite software image named **satellite-2.0R1.2-signed.tgz** that is currently stored in the `/var/tmp/` directory from the aggregation device to the upgrade group named **group1**:

```
user@aggregation-device> request system software add /var/tmp/satellite-2.0R1.2-signed.tgz
upgrade-group group1
```

To associate a satellite software package that was previously installed on the aggregation device with a software upgrade group:

```
user@aggregation-device> request system software add version version upgrade-group group1
```

For instance:

```
user@aggregation-device> request system software add version 2.0R1.2 upgrade-group group1
```

The satellite software upgrade group is associated with the software package after either of these commands are entered.

NOTE: A satellite software upgrade group can be a user-configured upgrade group or the name of a satellite device cluster.

If the group was already associated with a satellite software upgrade group, the previous satellite software package associated with the software group remains the second option for updating satellite software for the satellite software upgrade group. You can disassociate any satellite software package from a satellite software upgrade group using the instructions in the next section.

To associate a new satellite software image with the software upgrade group:

Deleting Associated Satellite Software from a Satellite Software Upgrade Group

This section describes how to delete a satellite software package association from a satellite software upgrade group.

This procedure is always optional. You can always update the satellite software associated with a satellite software upgrade group using the procedure in the previous section, without deleting the satellite software from the satellite software upgrade group.

When a new satellite software package is associated with a satellite software upgrade, the previous satellite software package remains associated with the upgrade group as a backup option. The satellite software upgrade group can be associated with up to two satellite software packages, so no other satellite software packages can be associated with the satellite software upgrade group.

This process disassociates the specified satellite software package from the list of potential packages used by a satellite software upgrade group. It is useful for maintenance purposes only, like if you wanted to ensure a satellite software upgrade group was never associated with a specific satellite software package.

To disassociate a satellite software image from a satellite software upgrade group:

```
user@aggregation-device> request system software delete upgrade-group upgrade-group-name
```

where the *upgrade-group-name* is the name of the upgrade group that was assigned by the user.

For example, to delete the current satellite software image association to the upgrade group named **group1**:

```
user@aggregation-device> request system software delete upgrade-group group1
```

Deleting Satellite Software on the Aggregation Device

This section describes how to remove a satellite software package from a Junos Fusion system. This will remove the software from the aggregation device as well as any association with any satellite software upgrade groups. This should be done when another satellite software version is available and will free up the space occupied by the software being removed.

NOTE: We recommend deleting satellite software that is not in use to free up space on a QFX10000 acting as an aggregation device.

```
user@aggregation-device> request system software delete version version
```

For example:

```
user@aggregation-device> request system software delete version 2.0R1.2
```

RELATED DOCUMENTATION

[Configuring Junos Fusion Provider Edge](#)

[Configuring or Expanding a Junos Fusion Enterprise](#)

Upgrading Junos OS and Satellite Software in an Operational Junos Fusion Enterprise with Dual Aggregation Devices

You may have to upgrade Junos OS on the aggregation devices in your Junos Fusion Enterprise after initial setup.

To ensure consistent behavior and feature support in your Junos Fusion Enterprise, we strongly recommend that both aggregation devices—and both Routing Engines in the aggregation devices—run the same version of Junos OS.

Satellite software should also be upgraded after the Junos OS upgrade to ensure it is compatible with the upgraded Junos OS.

We recommend following this procedure to upgrade Junos OS in a Junos Fusion Enterprise using a dual aggregation device topology:

1. Upgrade the Junos OS software on the backup Routing Engine of one of the aggregation devices. Do not reboot the backup Routing Engine to complete the upgrade at this point of the procedure. See [Junos Fusion Hardware and Software Compatibility Matrices](#) for software compatibility information and to retrieve Junos OS images for EX9200 switches that can act as aggregation devices in a Junos Fusion Enterprise.

This step is performed in this example by showing an upgrade to 17.2R1 with a Junos OS image that is installed in the local /var/tmp folder. See [Understanding Software Installation on EX Series Switches](#) for information on other procedures that can be used to upgrade Junos OS running on a Routing Engine on an EX9200 switch.

```
user@ad2-ex9208> request system software add /var/tmp/junos-install-ex92xx-  
x86-64-17.1R2.7.tgz re1
```

2. Upgrade the Junos OS software on the primary Routing Engine of the same aggregation device. Do not reboot the primary Routing Engine to complete the upgrade at this point of the procedure.

```
user@ad2-ex9208> request system software add /var/tmp/junos-install-ex92xx-  
x86-64-17.1R2.7.tgz re0
```

3. After steps 1 and 2 are completed successfully, reboot both Routing Engines simultaneously:

```
user@ad2-ex9208> request system reboot both-routing-engines
```

4. Repeat the same procedure on the other aggregation device:

```
user@ad1-ex9208> request system software add /var/tmp/junos-install-ex92xx-  
x86-64-17.1R2.7.tgz re1  
user@ad1-ex9208> request system software add /var/tmp/junos-install-ex92xx-  
x86-64-17.1R2.7.tgz re0  
user@ad1-ex9208> request system reboot both-routing-engines
```

5. After all Routing Engines on both aggregation devices have rebooted to complete the Junos OS upgrade, upgrade the satellite software on all satellite devices to the satellite software version that is compatible with the Junos OS running on the aggregation devices.

To identify the version of satellite software that works with the new version of Junos OS, see [Junos Fusion Hardware and Software Compatibility Matrices](#).

To install the new version of satellite software, see [Installing Satellite Software and Adding Satellite Devices to the Junos Fusion](#) and [Modifying the Satellite Software Used by a Satellite Software Upgrade Group](#).

RELATED DOCUMENTATION

[Junos Fusion Hardware and Software Compatibility Matrices](#)

[Installing Satellite Software and Adding Satellite Devices to the Junos Fusion](#)

Verifying Connectivity, Device States, Satellite Software Versions, and Operations in a Junos Fusion

IN THIS SECTION

- [Verifying a Junos Fusion Configuration | 161](#)
- [Verifying Basic Junos Fusion Connectivity | 162](#)
- [Verifying the Satellite Device Hardware Model | 164](#)
- [Verifying Cascade Port and Uplink Port State | 165](#)
- [Verifying That a Cascade Port Recognizes a Satellite Device | 169](#)
- [Verifying Extended Port Operation | 172](#)
- [Verifying the Satellite Software Version | 175](#)
- [Verifying the Devices and Software Used in a Satellite Software Upgrade Group | 176](#)

This topic provides information on common procedures to verify connectivity, device states, satellite software versions, and other operations in a Junos Fusion. It covers:

Verifying a Junos Fusion Configuration

IN THIS SECTION

- [Purpose | 162](#)
- [Action | 162](#)
- [Meaning | 162](#)

Purpose

Verify that a device is recognized as a satellite device by the aggregation device.

Action

Enter the **show chassis satellite** command and review the output.

```
user@aggregation-device> show chassis satellite
```

Alias	Slot	Device State	Cascade Ports	Port State	Extended Ports Total/Up
qfx5100-24q-01	100	Online	xe-0/0/1 xe-1/3/0	online	9/2
qfx5100-24q-02	101	Online	xe-0/0/2 xe-1/3/1	online	20/10
qfx5100-24q-03	102	Online	xe-0/0/3 xe-1/3/2	online	16/4
qfx5100-24q-04	103	Online	xe-0/0/4 xe-1/3/3	absent online	13/3
ex4300-01	109	Online	xe-1/0/1	online	49/2
ex4300-02	110	Online	xe-1/0/2	online	49/2

Meaning

Use the output of **show chassis satellite** to confirm the following connections in a Junos Fusion:

- Whether a satellite device is recognized at all by the aggregation device. If the satellite device does not appear in the **show chassis satellite** output, then it is not recognized by the aggregation device as a satellite device.
- The state of a particular satellite device, via the **Device State** output.
- The state of the cascade port connection, via the **Cascade State** output.

Verifying Basic Junos Fusion Connectivity

IN THIS SECTION

- Purpose | 163
- Action | 163

● Meaning | 164

Purpose

Verify that all satellite devices are recognized by the aggregation device, and that all cascade and extended ports are recognized.

Action

Enter the `show chassis satellite` command on the aggregation device.

```
user@aggregation-device> show chassis satellite
```

Alias	Slot	Device State	Cascade Ports	Port State	Extended Ports Total/Up
qfx5100-24q-01	100	Online	xe-0/0/1 xe-1/3/0	online online	9/2
qfx5100-24q-02	101	Online	xe-0/0/2 xe-1/3/1	online online	20/12
qfx5100-24q-03	102	Online	xe-0/0/3 xe-1/3/2	online online	16/6
qfx5100-24q-04	103	Online	xe-0/0/4 xe-1/3/3	online online	16/4
qfx5100-24q-05	104	Online	xe-0/0/5 xe-1/3/4	online online	13/3
qfx5100-24q-06	105	Online	xe-0/0/6 xe-1/3/5	online online	24/15
qfx5100-24q-07	106	Online	xe-0/0/7 xe-1/3/6	online online	24/15
qfx5100-24q-08	107	Online	xe-0/0/8 xe-1/3/7	online online	21/12
ex4300-01	109	Online	xe-1/0/1	online	49/2
ex4300-02	110	Online	xe-1/0/2	online	49/2
ex4300-03	111	Online	xe-1/0/3	online	49/2
ex4300-04	112	Online	xe-1/0/4	online	49/11
ex4300-05	113	Online	xe-1/0/5	online	49/11
ex4300-06	114	Online	xe-1/0/6	online	49/11
ex4300-07	115	Online	xe-1/0/7	online	49/11
ex4300-08	116	Online	xe-1/1/0	online	49/11
ex4300-09	117	Online	xe-1/1/1	online	49/11

ex4300-10	118	Online	xe-1/1/2	online	49/11
ex4300-11	119	Online	xe-1/1/3	online	49/11
ex4300-12	120	Online	xe-1/1/4	online	49/11
ex4300-13	121	Online	xe-1/1/5	online	49/11
ex4300-14	122	Online	xe-1/1/6	online	49/11
ex4300-15	123	Online	xe-1/1/7	online	49/11
ex4300-16	124	Online	xe-1/2/1	online	49/11
ex4300-17	125	Online	xe-1/2/2	online	49/11
ex4300-18	126	Online	xe-1/2/3	online	49/2
ex4300-19	127	Online	xe-1/2/4	online	49/1
ex4300-20	128	Online	xe-1/2/5	online	49/1
ex4300-21	129	Online	xe-1/2/6	online	49/1
ex4300-22	130	Online	xe-1/2/7	online	49/1

Meaning

The output confirms:

- Each listed satellite device—the satellite devices are listed by alias-name in the `Alias` column or by FPC slot ID in the `Slot` column—is recognized by the aggregation device, because the `Device State` output is `Online` for every listed satellite device.
- Each cascade port is operational, because `Port State` is `online` for every cascade port. The cascade port is the port on the aggregation device that connects to the satellite device.
- The number of available and active extended ports for each satellite device, using the `Extended Ports total` and `Extended Ports up` outputs. The number of extended ports varies by satellite devices, and in this output the total number of extended ports includes both network-facing extended ports as well as uplink ports.

Verifying the Satellite Device Hardware Model

IN THIS SECTION

- [Purpose | 165](#)
- [Action | 165](#)
- [Meaning | 165](#)

Purpose

Verify the hardware model of each satellite device in the Junos Fusion.

Action

Enter the `show chassis satellite terse` command on the aggregation device.

```
user@aggregation-device> show chassis satellite terse
```

Device		Extended Ports		
Slot	State	Model	Total/Up	Version
101	Online	QFX5100-48S-6Q	7/6	3.0R1.0
102	Online	QFX5100-48S-6Q	7/6	3.0R1.0
103	Online	QFX5100-48S-6Q	6/4	3.0R1.0
104	Online	QFX5100-48S-6Q	14/14	3.0R1.0
105	Online	QFX5100-48S-6Q	18/18	3.0R1.0
106	Online	QFX5100-48S-6Q	17/16	3.0R1.0
107	Online	EX4300-48T	52/6	3.0R1.0
108	Online	EX4300-48T	52/13	3.0R1.0
109	Online	EX4300-48T	51/13	3.0R1.0
110	Online	EX4300-48T	51/14	3.0R1.0
111	Online	EX4300-48T	51/13	3.0R1.0
112	Online	EX4300-48T	51/12	3.0R1.0
113	Online	EX4300-48T	51/13	3.0R1.0
114	Online	QFX5100-24Q-2P	17/13	3.0R1.0

Meaning

The output shows the device model of each satellite device in the `Device Model` output, which are listed by FPC slot identification number using the `Slot` output.

This command is also useful for verifying the version satellite software running on each satellite device, as the version is listed in the `Version` output.

Verifying Cascade Port and Uplink Port State

IN THIS SECTION

● Purpose | 166

● Action | 166

- [Meaning | 169](#)

Purpose

Verify that the cascade port and uplink port interfaces are up.

Action

Enter the `show chassis satellite interface` command:

```
user@aggregation-device> show chassis satellite interface
```

Interface	State	Type
lo0	Up	Loopback
sd-101/0/0	Up	Satellite
sd-102/0/0	Up	Satellite
sd-103/0/0	Up	Satellite
sd-104/0/0	Up	Satellite
sd-105/0/0	Up	Satellite
sd-106/0/0	Up	Satellite
sd-107/0/0	Up	Satellite
sd-108/0/0	Up	Satellite
sd-109/0/0	Up	Satellite
sd-110/0/0	Up	Satellite
sd-111/0/0	Up	Satellite
sd-112/0/0	Up	Satellite

sd-113/0/0	Up	Satellite
sd-114/0/0	Up	Satellite
xe-0/0/1	Up	Cascade
xe-0/0/2	Up	Cascade
xe-0/0/3	Up	Cascade
xe-0/0/4	Up	Cascade
xe-0/0/5	Up	Cascade
xe-0/0/6	Up	Cascade
xe-0/0/7	Up	Cascade
xe-0/0/8	Up	Cascade
xe-0/0/9	Up	Cascade
xe-0/2/0	Up	Cascade
xe-0/2/1	Up	Cascade
xe-0/2/2	Up	Cascade
xe-0/2/3	Up	Cascade
xe-0/2/4	Up	Cascade
xe-0/2/5	Up	Cascade
xe-0/2/6	Up	Cascade
xe-0/2/7	Up	Cascade
xe-1/0/1	Up	Cascade
xe-1/0/2	Up	Cascade

xe-1/0/3	Up	Cascade
xe-1/2/1	Up	Cascade
xe-1/2/2	Up	Cascade
xe-1/2/3	Up	Cascade
xe-2/0/0	Up	Cascade
xe-2/0/1	Up	Cascade
xe-2/0/2	Up	Cascade
xe-2/0/3	Up	Cascade
xe-2/0/4	Up	Cascade
xe-2/0/5	Up	Cascade
xe-2/0/6	Up	Cascade
xe-2/0/7	Up	Cascade
xe-2/1/0	Up	Cascade
xe-2/1/1	Up	Cascade
xe-2/1/2	Up	Cascade
xe-2/1/3	Up	Cascade
xe-2/1/4	Up	Cascade
xe-2/1/5	Up	Cascade
xe-2/1/6	Up	Cascade
xe-2/1/7	Up	Cascade
xe-2/2/0	Up	Cascade
xe-2/2/1	Up	Cascade

xe-2/2/2	Up	Cascade
xe-2/2/3	Up	Cascade
xe-2/2/4	Up	Cascade
xe-2/2/5	Up	Cascade
xe-2/2/6	Up	Cascade
xe-2/2/7	Up	Cascade
xe-2/3/0	Up	Cascade
xe-2/3/3	Dn	Cascade
xe-2/3/4	Up	Cascade
xe-2/3/5	Up	Cascade
xe-2/3/6	Up	Cascade
xe-2/3/7	Up	Cascade

Meaning

The output shows:

- Whether the recognized port is up or down, using the State column output. The State column output is Up when the interface is up and Dn when the interface is down.

Verifying That a Cascade Port Recognizes a Satellite Device

IN THIS SECTION

- Purpose | 170
- Action | 170
- Meaning | 172

Purpose

Verify that a cascade port on an aggregation device recognizes a satellite device in the Junos Fusion. This procedure also provides a method of verifying the hardware and software information for each satellite device in the Junos Fusion.

Action

Enter the show chassis satellite neighbor command:

```

user@aggregation-device> show chassis satellite neighbor
Interface  State      Port Info  System Name  Model          SW Version
xe-2/3/7   Init
xe-2/3/6   Init
xe-2/3/5   Init
xe-2/3/4   Init
xe-2/3/3   Dn
xe-2/3/0   Two-Way   xe-0/2/2    ex4300-29 EX4300-48T    0.1I20150224_182
7_dc-builder
xe-2/2/7   Two-Way   xe-0/2/2    ex4300-28 EX4300-48T    0.1I20150224_182
7_dc-builder
xe-2/2/6   Two-Way   xe-0/2/2    ex4300-27 EX4300-48T    0.1I20150224_182
7_dc-builder
xe-2/2/5   Two-Way   xe-0/2/2    ex4300-26 EX4300-48T    0.1I20150224_182
7_dc-builder
xe-2/2/4   Init
xe-2/2/3   Init
xe-2/2/2   Two-Way   xe-0/0/48:3 qfx5100-48s-06 QFX5100-48S-6Q 0.1I20150224_18
27_dc-builder
xe-2/2/1   Two-Way   xe-0/0/48:3 qfx5100-48s-05 QFX5100-48S-6Q 0.1I20150224_18
27_dc-builder
xe-2/2/0   Init
xe-2/1/7   Init
xe-2/1/6   Init
xe-2/1/5   Two-Way   xe-0/0/4:2  qfx5100-24q-09 QFX5100-24Q-2P 0.1I20150224_18
27_dc-builder
xe-2/1/4   Two-Way   xe-0/2/1    ex4300-31 EX4300-48T    0.1I20150224_182
7_dc-builder
xe-2/1/3   Two-Way   xe-0/2/1    ex4300-30 EX4300-48T    0.1I20150224_182
7_dc-builder
xe-2/1/2   Two-Way   xe-0/2/1    ex4300-29 EX4300-48T    0.1I20150224_182
7_dc-builder

```

```

xe-2/1/1    Two-Way    xe-0/2/1      ex4300-28 EX4300-48T    0.1I20150224_182
7_dc-builder
xe-2/1/0    Init
xe-2/0/7    Two-Way    xe-0/2/1      ex4300-26 EX4300-48T    0.1I20150224_182
7_dc-builder
xe-2/0/6    Init
xe-2/0/5    Init
xe-2/0/4    Init
xe-2/0/3    Init
xe-2/0/2    Two-Way    xe-0/0/48:2  qfx5100-48s-04 QFX5100-48S-6Q 0.1I20150224_18
27_dc-builder
xe-2/0/1    Two-Way    xe-0/0/48:2  qfx5100-48s-03 QFX5100-48S-6Q 0.1I20150224_18
27_dc-builder
xe-2/0/0    Init
xe-1/2/3    Two-Way    xe-0/0/0:0    qfx5100-24q-09 QFX5100-24Q-2P 0.1I20150224_18
27_dc-builder
xe-1/2/2    Two-Way    xe-0/2/0      ex4300-31 EX4300-48T    0.1I20150224_182
7_dc-builder
xe-1/2/1    Two-Way    xe-0/2/0      ex4300-30 EX4300-48T    0.1I20150224_182
7_dc-builder
xe-1/0/3    Two-Way    xe-0/2/0      ex4300-29 EX4300-48T    0.1I20150224_182
7_dc-builder
xe-1/0/2    Two-Way    xe-0/2/0      ex4300-28 EX4300-48T    0.1I20150224_182
7_dc-builder
xe-1/0/1    Two-Way    xe-0/2/0      ex4300-27 EX4300-48T    0.1I20150224_182
7_dc-builder
xe-0/2/7    Two-Way    xe-0/0/0:1    qfx5100-24q-09 QFX5100-24Q-2P 0.1I20150224_18
27_dc-builder
xe-0/2/6    Init
xe-0/2/5    Init
xe-0/2/4    Two-Way    xe-0/0/48:1  qfx5100-48s-05 QFX5100-48S-6Q 0.1I20150224_18
27_dc-builder
xe-0/2/3    Two-Way    xe-0/0/48:1  qfx5100-48s-04 QFX5100-48S-6Q 0.1I20150224_18
27_dc-builder
xe-0/2/2    Two-Way    xe-0/0/48:1  qfx5100-48s-03 QFX5100-48S-6Q 0.1I20150224_18
27_dc-builder
xe-0/2/1    Init
xe-0/2/0    Init
xe-0/0/9    Two-Way    xe-0/2/0      ex4300-26 EX4300-48T    0.1I20150224_182
7_dc-builder
xe-0/0/8    Two-Way    xe-0/2/0      ex4300-25 EX4300-48T    0.1I20150224_182
7_dc-builder
xe-0/0/7    Two-Way    xe-0/0/48:0  qfx5100-48s-07 QFX5100-48S-6Q 0.1I20150224_18

```

```

27_dc-builder
xe-0/0/6    Two-Way    xe-0/0/48:0 qfx5100-48s-06 QFX5100-48S-6Q 0.1I20150224_18
27_dc-builder
xe-0/0/5    Two-Way    xe-0/0/48:0 qfx5100-48s-05 QFX5100-48S-6Q 0.1I20150224_18
27_dc-builder
xe-0/0/4    Two-Way    xe-0/0/48:0 qfx5100-48s-04 QFX5100-48S-6Q 0.1I20150224_18
27_dc-builder
xe-0/0/3    Two-Way    xe-0/0/48:0 qfx5100-48s-03 QFX5100-48S-6Q 0.1I20150224_18
27_dc-builder
xe-0/0/2    Two-Way    xe-0/0/48:0 qfx5100-48s-02 QFX5100-48S-6Q 0.1I20150224_18
27_dc-builder
xe-0/0/1    Init

```

Meaning

The output confirms:

- The cascade ports on the aggregation device that are recognized by the Junos Fusion. All recognized cascade port interfaces are listed in the `Interface` output.
- The uplink ports on the satellite devices that are connected to the cascade ports. The cascade port on each satellite device is identified in the `Port Info` column, and the satellite device itself is identified in the `System Name` output.
- Whether the cascade port to uplink port connection has initialized, using the `State` output. The `State` output is `Two-Way` when the satellite device is properly initialized, and traffic can be passed between the aggregation device and the satellite device over the link.
- The hardware model of each satellite device in the `Model` column, and the satellite software running on each satellite device in the `SW Version` output.

Verifying Extended Port Operation

IN THIS SECTION

- [Purpose | 173](#)
- [Action | 173](#)
- [Meaning | 174](#)

Purpose

Verify that a specific extended port is recognized by the aggregation device, and is operational.

Action

Enter the `show chassis satellite extended-port` command on the aggregation device:

```
user@aggregation-device> show chassis satellite extended-port
Legend for interface types:
  * -- Uplink interface
```

Name	State	Rx Request	Tx State	Admin/Op State	IFD Idx	PCID
et-100/0/2	AddComplete	None	Ready	Up/Dn	838	110
et-104/0/2	AddComplete	None	Ready	Up/Dn	813	110
et-107/0/23	AddComplete	None	Ready	Up/Up	544	194
ge-109/0/0	AddComplete	None	Ready	Up/Up	402	115
ge-109/0/1	AddComplete	None	Ready	Up/Dn	403	114
ge-109/0/10	AddComplete	None	Ready	Up/Dn	412	113
ge-109/0/11	AddComplete	None	Ready	Up/Dn	413	112
ge-109/0/12	AddComplete	None	Ready	Up/Dn	414	123
ge-109/0/13	AddComplete	None	Ready	Up/Dn	415	122
ge-109/0/14	AddComplete	None	Ready	Up/Dn	416	125
ge-109/0/15	AddComplete	None	Ready	Up/Dn	417	124
ge-109/0/16	AddComplete	None	Ready	Up/Dn	418	131
ge-109/0/17	AddComplete	None	Ready	Up/Dn	419	130
ge-109/0/18	AddComplete	None	Ready	Up/Dn	420	133
ge-109/0/19	AddComplete	None	Ready	Up/Dn	421	132
ge-109/0/2	AddComplete	None	Ready	Up/Dn	404	117
ge-109/0/20	AddComplete	None	Ready	Up/Dn	422	127
ge-109/0/21	AddComplete	None	Ready	Up/Dn	423	126
ge-109/0/22	AddComplete	None	Ready	Up/Dn	424	129
ge-109/0/23	AddComplete	None	Ready	Up/Dn	425	128
ge-109/0/24	AddComplete	None	Ready	Up/Dn	426	103
ge-109/0/25	AddComplete	None	Ready	Up/Dn	427	102
ge-109/0/26	AddComplete	None	Ready	Up/Dn	428	105
ge-109/0/27	AddComplete	None	Ready	Up/Dn	429	104
ge-109/0/28	AddComplete	None	Ready	Up/Dn	430	107
ge-109/0/29	AddComplete	None	Ready	Up/Dn	431	106
ge-109/0/3	AddComplete	None	Ready	Up/Dn	405	116
ge-109/0/30	AddComplete	None	Ready	Up/Dn	432	109
ge-109/0/31	AddComplete	None	Ready	Up/Dn	433	108

ge-109/0/32	AddComplete	None	Ready	Up/Dn	434	135
ge-109/0/33	AddComplete	None	Ready	Up/Dn	435	134
ge-109/0/34	AddComplete	None	Ready	Up/Dn	436	137
ge-109/0/35	AddComplete	None	Ready	Up/Dn	437	136
ge-109/0/36	AddComplete	None	Ready	Up/Dn	438	144
ge-109/0/37	AddComplete	None	Ready	Up/Dn	439	143
ge-109/0/38	AddComplete	None	Ready	Up/Dn	440	146
ge-109/0/39	AddComplete	None	Ready	Up/Dn	441	145
ge-109/0/4	AddComplete	None	Ready	Up/Dn	406	119
ge-109/0/40	AddComplete	None	Ready	Up/Dn	442	140
ge-109/0/41	AddComplete	None	Ready	Up/Dn	443	139
ge-109/0/42	AddComplete	None	Ready	Up/Dn	444	142
ge-109/0/43	AddComplete	None	Ready	Up/Dn	445	141
ge-109/0/44	AddComplete	None	Ready	Up/Dn	446	148
ge-109/0/45	AddComplete	None	Ready	Up/Dn	447	147
ge-109/0/46	AddComplete	None	Ready	Up/Dn	448	150
ge-109/0/47	AddComplete	None	Ready	Up/Dn	449	149
ge-109/0/5	AddComplete	None	Ready	Up/Dn	407	118
ge-109/0/6	AddComplete	None	Ready	Up/Dn	408	121
ge-109/0/7	AddComplete	None	Ready	Up/Dn	409	120
ge-109/0/8	AddComplete	None	Ready	Up/Dn	410	111
ge-109/0/9	AddComplete	None	Ready	Up/Dn	411	110
ge-110/0/0	AddComplete	None	Ready	Up/Up	728	115
ge-110/0/1	AddComplete	None	Ready	Up/Dn	729	114

Meaning

The output confirms:

- That an extended port is recognized by the aggregation device. All extended ports are listed in the Name column of the output.
- That the listed extended ports have been added to the Junos Fusion, as shown by the AddComplete output in the State column.
- The administrative and operational state of each extended port. An extended port is operating correctly when the Admin State and Op State outputs are both in the Up state.

Verifying the Satellite Software Version

IN THIS SECTION

- Purpose | 175
- Action | 175
- Meaning | 176

Purpose

Verify the satellite software versions available on the aggregation device in a Junos Fusion.

Action

Enter the `show chassis satellite software` command on the aggregation device.

```
user@aggregation-device> show chassis satellite software
Version           Platforms      Group
3.0R1.1           i386 ppc      group1
                  i386 ppc      group2
                  i386 ppc      group3
                  i386 ppc      group4
                  i386 ppc      group5
3.0R1.0           i386 ppc
```

For more detailed output, you can also enter the `show chassis satellite software detail` on the aggregation device.

```
Software package version: 3.0R1.6
Platforms supported by package: i386 ppc arm arm563xx
Platform  Host Version  Models Supported
i386      3.0.3        QFX5100-24Q-2P
          3.0.3        QFX5100-48C-6Q
          3.0.3        QFX5100-48S-6Q
          3.0.3        QFX5100-48T-6Q
          3.0.3        QFX5100-96S-8Q
          3.0.3        QFX5100-48SH-6Q
```

ppc	1.1.2	QFX5100-48TH-6Q EX4300-24P EX4300-24T EX4300-48P EX4300-48T EX4300-48T-BF EX4300-48T-DC EX4300-48T-DC-BF
arm	1.0.0	EX2300-24P EX2300-24T-DC EX2300-C-12T EX4300-C-12P
arm563xx	1.0.0	EX3400-24P EX3400-24T EX3400-48T EX3400-48P
Current Groups: group1 group2 group3 group4 group5		

Meaning

The version of satellite software installed is displayed in the Version or Software package version column, and the satellite software upgrade group associated with each version of satellite software is listed in the Group or Current Groups output.

Verifying the Devices and Software Used in a Satellite Software Upgrade Group

IN THIS SECTION

- Purpose | 177
- Action | 177
- Meaning | 177

Purpose

Verify the satellite software upgrade groups in the Junos Fusion, and which satellite devices are part of which satellite software upgrade groups.

A satellite software upgrade group can be a user configured group or the name of a satellite device cluster.

Action

Enter the `show chassis satellite upgrade-group` command on the aggregation device.

`show chassis satellite upgrade-group`

```
user@aggregation-device> show chassis satellite upgrade-group
```

Group	Sw-Version	Group State	Slot	Device State
__ungrouped__				
group1	3.0R1.1	in-sync	107	version-in-sync
			108	version-in-sync
			109	version-in-sync
			110	version-in-sync
			111	version-in-sync
			112	version-in-sync
			113	version-in-sync
group2	3.0R1.1	in-sync	102	version-in-sync
			103	version-in-sync
			104	version-in-sync
			105	version-in-sync
			106	version-in-sync
			114	version-in-sync

Meaning

The output shows that two satellite software upgrade groups—`ex4300` and `qfx`—have been created, and that both are using satellite software version `1.0R1.1`. The `Group Slot` output shows which satellite devices—listed by FPC slot ID number—are in which software group, and the `Device State` output showing `version-in-sync` confirms that the satellite devices are running the satellite software that is associated with the satellite software upgrade group.

RELATED DOCUMENTATION

[Configuring Junos Fusion Provider Edge](#)

[Configuring or Expanding a Junos Fusion Enterprise](#)

Converting a Satellite Device in a Junos Fusion to a Standalone Device

IN THIS SECTION

- [Download Junos OS Software | 178](#)
- [Disable the Automatic Conversion Configuration | 179](#)
- [Install Junos OS Software on the Satellite Device | 180](#)

In the event that you need to convert a satellite device to a standalone device, you will need to download and install a new Junos OS software package on the satellite device. The satellite device stops participating in the Junos Fusion topology once the software installation starts.

The following steps explain how to convert a satellite device that is participating in a Junos Fusion to a standalone device running Junos OS. If you have a standalone switch that is not part of a Junos Fusion but is running satellite software, and you want the switch to run Junos OS software, see "[Installing Junos OS Software on a Standalone Device Running Satellite Software](#)" on page 182.

NOTE: The QFX5100-48SH and QFX5100-48TH switch models are shipped from the factory with satellite device software. You cannot convert these switches to become standalone devices. Conversion of EX2300 and EX3400 switches from satellite devices to standalone devices cannot be initiated from the aggregation device. To install Junos OS software on an EX2300 or EX3400 switch acting as a satellite device, see "[Installing Junos OS Software on a Standalone Device Running Satellite Software](#)" on page 182.

Download Junos OS Software

Before you install a new Junos OS software package on a satellite device, make sure you download the correct software package for that device:

- If the satellite device is a QFX5110, QFX5200 or EX4300 switch, you install a standard, signed **jinstall** version of Junos OS.

- If the satellite device is a QFX5100 switch that can be converted to a standalone device, you must install a Preboot eXecution Environment (PXE) version of Junos OS. The PXE version of Junos OS software supports the same feature set as the other Junos OS software packages for a release, but is specially engineered to install Junos OS onto a device running satellite software. The PXE Junos OS package name uses the format **install-media-pxe-qfx-5-*version*-domestic.tgz**.
- For Junos Fusion systems running Junos OS Release 17.2R1 and later, if the satellite device is a QFX5100 switch that can be converted to a standalone device, you must install a signed PXE version of Junos OS to convert the satellite device running satellite software to a standalone device running Junos OS software. The signed PXE Junos OS package name uses the format **install-media-pxe-qfx-5-*version*-domestic-signed.tgz**.

To download the version of Junos OS that you want to run on the satellite device after removing it from the Junos Fusion:

1. Using a Web browser, navigate to the Junos OS software download URL on the Juniper Networks webpage:
<https://www.juniper.net/support/downloads>
2. Log in to the Juniper Networks authentication system using the username (generally your e-mail address) and password supplied by Juniper Networks representatives.
3. Select **By Technology > Junos Platform > Junos Fusion** from the drop-down list and select the switch platform series and model for your satellite device.
4. Select the version of Junos OS that you want to run on the satellite device after removing it from the Junos Fusion.
5. Review and accept the End User License Agreement.
6. Download the software to a local host.
7. Copy the software to the routing platform or to your internal software distribution site.

Disable the Automatic Conversion Configuration

Before removing a satellite device from an operational Junos Fusion, you must disable the configuration for automatic satellite conversion. If automatic satellite conversion is enabled for the FPC slot ID, the Junos OS installation cannot proceed.

For example, the following installation on an EX4300 satellite device is blocked:

```
[edit]
user@aggregation-device> request chassis satellite install fpc-slot 103 /var/tmp/jinstall-
```

```
ex-4300-14.1X53-D43.7-domestic-signed.tgz
```

```
Convert satellite device to Junos standalone device? [yes,no] (no) yes
```

```
Verified jinstall-ex-4300-14.1X53-D43.7-domestic.tgz signed by PackageProductionEc_2017 method ECDSA256+SHA256
```

```
Satellite 103 is configured in the auto-satellite-conversion list
```

```
Please remove it from the list before converting to standalone
```

You can check the automatic satellite conversion configuration by entering the `show` statement at the `[edit chassis satellite-management auto-satellite-conversion]` hierarchy level.

1. If automatic satellite conversion is enabled for the satellite device's FPC slot ID, remove the FPC slot ID from the automatic satellite conversion configuration.

```
[edit]
user@aggregation-device# delete chassis satellite-management auto-satellite-conversion
satellite slot-id
```

For example, to remove FPC slot ID 103 from the Junos Fusion.

```
[edit]
user@aggregation-device# delete chassis satellite-management auto-satellite-conversion
satellite 103
```

2. Commit the configuration.

- To commit the configuration to a single Routing Engine only:

```
[edit]
user@aggregation-device# commit
```

- To commit the configuration to all Routing Engines in multiple-aggregation device topology:

```
[edit]
user@aggregation-device# commit synchronize
```

Install Junos OS Software on the Satellite Device

1. To install the Junos OS software on the satellite device to convert the device to a standalone device, use the following CLI command:

```
[edit]
user@aggregation-device> request chassis satellite install fpc-slot slot-id URL-to-software-package
```

For example, to install a software package stored in the `var/tmp` folder on the aggregation device onto an EX4300 switch acting as the satellite device using FPC slot 103:

```
[edit]
user@aggregation-device> request chassis satellite install fpc-slot 103 /var/tmp/jinstall-ex-4300-14.1X53-D43.7-domestic-signed.tgz
Convert satellite device to Junos standalone device? [yes,no] (no) yes
```

```
Verified jinstall-ex-4300-14.1X53-D43.7-domestic.tgz signed by PackageProductionEc_2017
method ECDSA256+SHA256
Initiating Junos standalone conversion on device 103...
Response from device: Conversion started
```

NOTE: If you are converting a QFX5100 switch and the Junos Fusion is running a Junos OS release earlier than 17.2R1, you must install the unsigned PXE software package on the QFX5100 switch:

```
[edit]
user@aggregation-device> request chassis satellite install fpc-slot 103 /var/tmp/install-media-pxe-qfx-5-14.1X53-D43.7-domestic.tgz
```

The satellite device stops participating in the Junos Fusion topology once the software installation starts. The software upgrade starts after this command is entered.

2. To check the progress of the conversion, issue the `show chassis satellite fpc-slot` command:

```
[edit]
user@aggregation-device> show chassis satellite fpc-slot 103 extensive
```

Alias	Slot	Device State	Cascade Ports	Port State	Extended Ports
ex4300-24t-16	103	Online	xe-1/0/3	online	52/29

xe-2/0/3	online	
When	Event	Action
Nov 30 15:48:22.914	Rx SW-Update JSON-RPC response	Conversion started
Nov 30 15:47:54.375	Start-SW-Update	Junos conversion

3. Wait for the reboot that accompanies the software installation to complete.
4. When you are prompted to log back into your device, uncache the device from the Junos Fusion topology. See *Remove a Transceiver*. Your device has been removed from Junos Fusion.

NOTE: The device uses a factory-default configuration after the Junos OS installation is complete.

Release History Table

Release	Description
17.2R1	For Junos Fusion systems running Junos OS Release 17.2R1 and later, if the satellite device is a QFX5100 switch that can be converted to a standalone device, you must install a signed PXE version of Junos OS to convert the satellite device running satellite software to a standalone device running Junos OS software.

RELATED DOCUMENTATION

[Understanding Software in a Junos Fusion Provider Edge](#)

[Understanding Software in a Junos Fusion Enterprise](#)

Installing Junos OS Software on a Standalone Device Running Satellite Software

This process should be used when you have a standalone switch running satellite software and you want the switch to run Junos OS software. A standalone device is running satellite software for one of the following reasons:

- It was removed from a Junos Fusion without following the instructions in "[Converting a Satellite Device in a Junos Fusion to a Standalone Device](#)" on page 178, which include a Junos OS installation.
- Satellite software was installed on the device but the device was never provisioned into a Junos Fusion.

NOTE: If you are removing a satellite device from a Junos Fusion, you must first make sure that automatic satellite conversion is disabled for the satellite device's FPC slot ID. See ["Converting a Satellite Device in a Junos Fusion to a Standalone Device" on page 178](#).

To install Junos OS onto a QFX5100, QFX5100 or QFX5200 switch running satellite software:

- Select a Junos OS image that meets the satellite software to Junos OS conversion requirements. See [Junos Fusion Hardware and Software Compatibility Matrices](#) for satellite software to Junos OS conversion requirements.
- Copy the Junos OS image onto a USB flash drive and use the USB flash drive to install the Junos OS. See [Performing a Recovery Installation Using an Emergency Boot Device](#).

To install Junos OS onto an EX4300 switch running satellite software:

1. Log in to the console port of your switch.
2. Power off the switch, and power it back on.
3. While the switch is powering back on, enter the UBoot prompt (=>) by pressing Ctrl+C on your keyboard.
4. From the Uboot prompt, set the operating system environment mode on the switch to Junos. Save the configuration and reset the kernel:

```
=> setenv osmode junos
=> setenv snos_previous_boot 0
=> save
=> reset
```

After the reset operation completes, the loader prompt (loader>) appears.

5. Install Junos OS using a USB flash drive from the loader prompt. See [Booting an EX Series Switch Using a Software Package Stored on a USB Flash Drive](#).

To install Junos OS onto an EX2300 or EX3400 switch running satellite software:

- Log in to the satellite software (SNOS) on the switch to be converted back to Junos OS and use the following sequence of commands to install the Junos package:

```
#####
dd bs=512 count=1 if=/dev/zero of=/dev/sda
```

```
echo -e "o\nn\np\n1\n\n\nw" | fdisk /dev/sda
mkfs.vfat /dev/sda1
fw_setenv target_os
reboot
#####
>>Get to the loader prompt
#####
loader> install --format tftp://<tftp server>/<Junos package name>
```

RELATED DOCUMENTATION

[Understanding Junos Fusion Enterprise Software and Hardware Requirements](#)

[Junos Fusion Hardware and Software Compatibility Matrices](#)

[Converting a Satellite Device in a Junos Fusion to a Standalone Device | 178](#)

Junos Fusion Enterprise Operational Commands

IN THIS CHAPTER

- request chassis device-mode satellite | 186
- request chassis satellite beacon | 188
- request chassis satellite disable | 190
- request chassis satellite enable | 192
- request chassis satellite file-copy | 193
- request chassis satellite install | 195
- request chassis satellite interface | 198
- request chassis satellite login | 199
- request chassis satellite reboot | 201
- request chassis satellite restart | 203
- request chassis satellite shell-command | 204
- request system software add (Junos OS) | 205
- request system software delete (Junos OS) | 223
- request system software rollback (Junos OS) | 228
- request system storage cleanup (Junos OS) | 234
- show chassis alarms | 249
- show chassis environment | 278
- show chassis environment fpc | 399
- show chassis environment pem | 479
- show chassis environment routing-engine | 501
- show chassis fan | 511
- show chassis firmware | 529
- show chassis hardware | 549
- show chassis led satellite | 577
- show chassis routing-engine | 583
- show chassis satellite | 594

- [show chassis satellite extended-port | 610](#)
- [show chassis satellite interface | 615](#)
- [show chassis satellite neighbor | 623](#)
- [show chassis satellite redundancy-group | 630](#)
- [show chassis satellite redundancy-group devices | 634](#)
- [show chassis satellite software | 637](#)
- [show chassis satellite statistics | 641](#)
- [show chassis satellite unprovision | 648](#)
- [show chassis satellite upgrade-group | 655](#)
- [show chassis satellite-cluster | 660](#)
- [show chassis satellite-cluster route | 668](#)
- [show chassis satellite-cluster statistics | 671](#)
- [show chassis temperature-thresholds | 676](#)
- [show interfaces extensive satellite-device | 705](#)
- [show interfaces satellite-device | 731](#)
- [show interfaces statistics | 738](#)
- [show interfaces terse satellite-device | 757](#)
- [show system core-dumps | 761](#)

request chassis device-mode satellite

IN THIS SECTION

- [Syntax | 187](#)
- [Description | 187](#)
- [Options | 187](#)
- [Required Privilege Level | 187](#)
- [Sample Output | 187](#)
- [Release Information | 187](#)

Syntax

```
request chassis device-mode satellite package-name
```

Description

Manually install satellite software onto a switch before interconnecting the switch as a satellite device into a Junos Fusion.

There are other methods of installing satellite software onto a satellite device, and each Junos Fusion has individual requirements for manually installing satellite software. See *Configuring Junos Fusion Provider Edge* or [Configuring or Expanding a Junos Fusion Enterprise](#) before manually installing satellite software.

This command is entered from a standalone device before it is configured into a satellite device in a Junos Fusion.

Options

package-name The URL to the satellite software package.

Required Privilege Level

system-control

Sample Output

```
request chassis device-mode satellite /var/tmp/satellite-3.0R1.1-signed.tgz
```

```
user@satellite-device> request chassis device-mode satellite /var/tmp/satellite-3.0R1.1-  
signed.tgz
```

Release Information

Command introduced in Junos OS Release 14.1X53-D16.

RELATED DOCUMENTATION

[Configuring Junos Fusion Provider Edge](#)

[Configuring or Expanding a Junos Fusion Enterprise](#)

request chassis satellite beacon

IN THIS SECTION

- [Syntax | 188](#)
- [Description | 188](#)
- [Options | 188](#)
- [Required Privilege Level | 189](#)
- [Sample Output | 189](#)
- [Release Information | 189](#)

Syntax

```
request chassis satellite beacon
  <(off | on)>
  <fpc-slot slot-id (off | on)>
  <range range (off | on)>
```

Description

This command is used to enable or disable the beacon LED on satellite devices in a Junos Fusion.

To display the status and colors of the beacon LEDs of the satellite devices in a Junos Fusion, use the `show chassis led satellite` command.

Options

off Turn the beacon LED off.

on	Turn the beacon LED on.
range <i>range</i>	Enable or disable the beacon LED in a range of FPC slot identifiers. For example, you can specify FPC slot identifiers 101, 102, and 103 by entering a range of 101-103.
fpc-slot <i>slot-id</i>	Enable or disable beacon LED for the satellite device using the specified FPC slot identifier in the Junos Fusion. The <i>slot-id</i> is the FPC slot ID number.

Required Privilege Level

maintenance

Sample Output

request chassis satellite beacon fpc-slot 136 on

```
user@aggregation-device> request chassis satellite beacon fpc-slot 136 on
```

request chassis satellite beacon range 101-103 off

```
user@aggregation-device> request chassis satellite beacon range 101-103 off
```

Release Information

Command introduced in Junos OS Release 14.2R3.

RELATED DOCUMENTATION

[show chassis led satellite | 577](#)

[Configuring or Expanding a Junos Fusion Enterprise | 50](#)

request chassis satellite disable

IN THIS SECTION

- [Syntax | 190](#)
- [Description | 190](#)
- [Options | 191](#)
- [Required Privilege Level | 191](#)
- [Sample Output | 191](#)
- [Sample Output | 191](#)
- [Release Information | 191](#)

Syntax

```
request chassis satellite disable
  <device-alias alias-name>
  <fpc-slot fpc-slot>
```

Description

Disable the specified satellite device from the Junos Fusion.

When a satellite device is disabled from a Junos Fusion, all extended ports are immediately placed in the down state. The satellite device cannot send or receive traffic for the Junos Fusion until it is reenabled.

This command is useful whenever you need to disable a satellite device from a Junos Fusion, such as for troubleshooting scenarios. If you are removing a satellite device from a Junos Fusion to use the device elsewhere on the network, use the ["request chassis satellite install" on page 195](#) command to install Junos OS onto your satellite device before removing it from the Junos Fusion. See [Removing a Satellite Device from a Junos Fusion](#).

You can reenable a satellite device that was disabled using this command using the ["request chassis satellite enable" on page 192](#) command.

Options

device-alias *alias-name* Disable the satellite device with the specified alias name from the Junos Fusion.

fpc *fpc-slot* Disable the satellite device with the specified FPC slot identifier from the Junos Fusion.

Required Privilege Level

system-control

Sample Output

request chassis satellite disable device-alias satellite-01

```
user@aggregation-device> request chassis satellite disable device-alias satellite-01
```

Sample Output

request chassis satellite disable fpc-slot 101

```
user@aggregation-device> request chassis satellite disable fpc-slot 101
```

Release Information

Command introduced in Junos OS Release 14.2R3.

RELATED DOCUMENTATION

[Configuring Junos Fusion Provider Edge](#)

[Configuring or Expanding a Junos Fusion Enterprise](#)

request chassis satellite enable

IN THIS SECTION

- [Syntax | 192](#)
- [Description | 192](#)
- [Options | 192](#)
- [Required Privilege Level | 193](#)
- [Sample Output | 193](#)
- [Sample Output | 193](#)
- [Release Information | 193](#)

Syntax

```
request chassis satellite enable
  <device-alias alias-name>
  <fpc-slot fpc-slot>
```

Description

Enable the specified device as a satellite device in a Junos Fusion.

This command is typically not used in any standard Junos Fusion initial configuration procedure. This command is typically needed in cases where the satellite device or cascade port has been disabled and needs to be re-enabled.

Options

- | | |
|---------------------------------------|---|
| device-alias <i>alias-name</i> | Enable the satellite device with the specified alias name in the Junos Fusion. |
| fpc <i>fpc-slot</i> | Enable the device with the specified FPC slot ID as a satellite device in the Junos Fusion. |

Required Privilege Level

system-control

Sample Output

request chassis satellite enable device-alias satellite-01

```
user@aggregation-device> request chassis satellite enable device-alias satellite-01
```

Sample Output

request chassis satellite enable fpc-slot 101

```
user@aggregation-device> request chassis satellite enable fpc-slot 101
```

Release Information

Command introduced in Junos OS Release 14.2R3.

RELATED DOCUMENTATION

[Configuring or Expanding a Junos Fusion Enterprise](#)

Configuring Junos Fusion Provider Edge

request chassis satellite file-copy

IN THIS SECTION

- [Syntax | 194](#)
- [Description | 194](#)
- [Options | 194](#)

- Required Privilege Level | 195
- Sample Output | 195
- Release Information | 195

Syntax

```
request chassis satellite file-copy [remote | local] <source-URL> <destination-URL>
```

Description

Copy a file between a satellite device and an aggregation device in a Junos Fusion.

Options

- local** Indicate that the file-copy from satellite-device has been initiated by a local user.
- remote** Indicate that the file-copy from satellite-device has been initiated by a remote user.
- source-URL*** Specify the URL of the file that is copied.
- If no device is specified as the *source-URL*, the file is copied from the aggregation device.
- To specify a satellite device in the *source-URL*, enter ***sdslot-id-number*** at the beginning of the *source-URL*. For example, enter ***sd101:/var/tmp/filename.txt*** to specify that filename.txt in the /var/tmp directory on the satellite device using FPC slot ID number 101 is the *source-URL*.
- destination-URL*** Specify the destination URL where the file is copied into.
- If no device is specified as the *destination-URL*, the file is copied into the aggregation device.
- To specify a satellite device in the *destination-URL*, enter ***sdslot-id-number*** at the beginning of the *destination-URL*. For example, enter ***sd101:/var/tmp/*** to specify the /var/tmp directory on the satellite device using FPC slot ID number 101 as the *source-URL*.

Required Privilege Level

system-control

Sample Output

request chassis satellite file-copy

```
root@aggregation-device> request chassis satellite file-copy local /var/tmp/file_name
sd101:/var/tmp/
```

Release Information

Command introduced in Junos OS Release 14.2R3.

RELATED DOCUMENTATION

[Configuring or Expanding a Junos Fusion Enterprise](#)

Configuring Junos Fusion Provider Edge

request chassis satellite install

IN THIS SECTION

- [Syntax | 196](#)
- [Description | 196](#)
- [Options | 197](#)
- [Required Privilege Level | 197](#)
- [Sample Output | 197](#)
- [Release Information | 197](#)

Syntax

```
request chassis satellite install package-name
  [fpc-slot fpc-slot | device-alias device-alias]
  <no-confirm>
```

Description

Install a version of Junos OS software onto a satellite device in a Junos Fusion.

Any device operating as a satellite device in a Junos Fusion is running satellite software. A device running satellite software cannot operate as a standalone network device until it is running a version of Junos OS software.

You would typically enter this command to install Junos OS onto a satellite device before removing the satellite device from a Junos Fusion. Installing the Junos OS software onto the satellite device before removing it from the Junos Fusion allows you to more easily install the device elsewhere in your network.

If you are using the automatic satellite conversion feature to convert devices into satellite devices in your Junos Fusion, remove the FPC slot ID to the satellite device from the automatic satellite conversion configuration before using this command to install the Junos OS software. You can update the automatic satellite conversion feature using the set `chassis satellite-management auto-satellite-conversion satellite slot-id` configuration statement.

You must install a PXE version of compatible Junos OS to convert the satellite device running satellite software to a standalone device running Junos OS software on QFX5100 switches acting as satellite devices. The PXE version of Junos OS is the software that includes **pxe** in the Junos OS package name when it is downloaded from the Software Center—for example, the PXE image for Junos OS Release 14.1X53-D16 is named **install-media-pxe-qfx-5-14.1X53-D16.2.tgz**.

For Junos Fusion systems running Junos OS Release 17.2R1 and later, you must install a signed PXE version of Junos OS to convert the satellite device running satellite software to a standalone device running Junos OS software. The signed PXE Junos OS package name uses the format **install-media-pxe-qfx-5-*version*-domestic-signed.tgz**.

The device uses a factory-default configuration after the Junos OS installation is complete. No Junos OS configuration is modified and the previous Junos OS configuration is not restored after the Junos OS software installation.

Options

<i>package-name</i>	Specify the URL to the Junos OS image to install onto the satellite device.
<i>fpc fpc-slot</i>	Install the Junos OS software onto the satellite device with the specified FPC slot ID in the Junos Fusion.
<i>device-alias device-alias</i>	Install the Junos OS software onto the satellite device with the alias name in the Junos Fusion.
<i>no-confirm</i>	(Optional) Install the Junos OS software onto the satellite device immediately without further confirmation prompting.

Required Privilege Level

system-control

Sample Output

request chassis satellite install /var/tmp/jinstall-ex-4300-14.1X53-D16.1-domestic-signed.tgz fpc-slot 101 (EX4300 switch as satellite device)

```
user@aggregation-device> request chassis satellite install /var/tmp/jinstall-ex-4300-14.1X53-D16.1-domestic-signed.tgz fpc-slot 101
Response from device:
  Conversion Started
```

request chassis satellite install /var/tmp/install-media-pxe-qfx-5-14.1X53-D16.2.tgz fpc-slot 102 (QFX5100 switch as satellite device)

```
user@aggregation-device> request chassis satellite install /var/tmp/install-media-pxe-qfx-5-14.1X53-D16.2.tgz fpc-slot 102
Response from device:
  Conversion Started
```

Release Information

Command introduced in Junos OS Release 14.2R3.

RELATED DOCUMENTATION

[Configuring or Expanding a Junos Fusion Enterprise](#)

Configuring Junos Fusion Provider Edge

request chassis satellite interface

IN THIS SECTION

- [Syntax | 198](#)
- [Description | 198](#)
- [Options | 199](#)
- [Required Privilege Level | 199](#)
- [Sample Output | 199](#)
- [Release Information | 199](#)

Syntax

```
request chassis satellite interface interface-name
device-mode satellite
```

Description

Change the device mode for a device.

This command is used to change a device into a satellite device for a Junos Fusion. After interconnecting a device to an aggregation device in a Junos Fusion, enter this command from the aggregation device to begin the manual satellite device conversion procedure.

Other configuration steps, such as configuring the cascade port and creating a satellite software upgrade group, must be completed before this command can be used to convert a device into a satellite device. See *Configuring Junos Fusion Provider Edge* or [Configuring or Expanding a Junos Fusion Enterprise](#).

Options

interface-name Specify the name of the cascade port interface on the aggregation device that connects to the device that will be converted into a satellite device.

Required Privilege Level

system-control

Sample Output

request chassis satellite interface xe-0/0/1 device-mode satellite

```
user@aggregation-device> request chassis satellite interface xe-0/0/1 device-mode satellite
```

Release Information

Command introduced in Junos OS Release 14.2R3.

RELATED DOCUMENTATION

[Configuring Junos Fusion Provider Edge](#)

[Configuring or Expanding a Junos Fusion Enterprise](#)

request chassis satellite login

IN THIS SECTION

- [Syntax | 200](#)
- [Description | 200](#)
- [Options | 200](#)
- [Required Privilege Level | 200](#)
- [Sample Output | 200](#)

Syntax

```
request chassis satellite login
  <fpc-slot fpc-slot>
  <interface-name interface-name>
```

Description

Log in to the satellite device from the aggregation device.

This command is typically used to log in to the satellite device by expert users for debugging purposes. You can perform all configuration and administration tasks in a Junos Fusion from the aggregation device.

Options

fpc <i>fpc-slot</i>	Log in to the satellite device with the specified FPC slot ID.
interface-name <i>interface-name</i>	Log in to the satellite device connected to the specified interface. The <i>interface-name</i> is the cascade port on the aggregation device.

Required Privilege Level

system-control

Sample Output

request chassis satellite login fpc-slot 101

```
user@aggregation-device> request chassis satellite login fpc-slot 101
```

Release Information

Command introduced in Junos OS Release 14.2R3.

RELATED DOCUMENTATION

[Configuring or Expanding a Junos Fusion Enterprise](#)

Configuring Junos Fusion Provider Edge

request chassis satellite reboot

IN THIS SECTION

- [Syntax | 201](#)
- [Description | 201](#)
- [Options | 202](#)
- [Required Privilege Level | 202](#)
- [Sample Output | 202](#)
- [Sample Output | 202](#)
- [Release Information | 202](#)

Syntax

```
request chassis satellite reboot
  <fpc-slot fpc-slot>
  <range range>
```

Description

Reboot the satellite device or devices from the aggregation device in a Junos Fusion.

Options

fpc *fpc-slot* Reboot the satellite device with the specified FPC slot identifier.

range *range* Reboot all satellite devices in a range of FPC slot identifiers.

For instance, you can reboot the satellite devices using FPC slot identifiers 101, 102, and 103 by entering a *range* of 101-103.

Required Privilege Level

system-control

Sample Output

request chassis satellite reboot fpc 101

```
user@aggregation-device> request chassis satellite reboot fpc 101
```

Sample Output

request chassis satellite reboot range 101-103

```
user@aggregation-device> request chassis satellite reboot range 101-103
```

Release Information

Command introduced in Junos OS Release 14.2R3.

RELATED DOCUMENTATION

[Configuring or Expanding a Junos Fusion Enterprise](#)

Configuring Junos Fusion Provider Edge

request chassis satellite restart

IN THIS SECTION

- [Syntax | 203](#)
- [Description | 203](#)
- [Options | 203](#)
- [Required Privilege Level | 204](#)
- [Release Information | 204](#)

Syntax

```
request chassis satellite restart
  [fpc-slot fpc-slot | range range]
  <process-name>
```

Description

Restart a process on a satellite device or devices from the aggregation device in a Junos Fusion.

You would typically restart a process in a Junos Fusion for troubleshooting or debugging purposes.

This command is intended for use by expert users for debugging purposes.

Options

fpc *fpc-slot* Restart the specified process on the satellite device in the specified FPC slot ID only.

range Restart the process on the satellite devices in the specified range of FPC slot IDs only.

For instance, if you want to reboot the satellite devices using FPC slot IDs 101, 102, and 103, you can enter a *range* of 101-103.

process-name Restart the specified process on the specified FPC slot ID or range of FPC slot IDs.

Required Privilege Level

system-control

Release Information

Command introduced in Junos OS Release 14.2R3.

RELATED DOCUMENTATION

[Configuring or Expanding a Junos Fusion Enterprise](#)

Configuring Junos Fusion Provider Edge

request chassis satellite shell-command

IN THIS SECTION

- [Syntax | 204](#)
- [Description | 204](#)
- [Options | 205](#)
- [Required Privilege Level | 205](#)
- [Release Information | 205](#)

Syntax

```
request chassis satellite shell-command  
  [fpc-slot fpc-slot | range ]  
  <remote-command>
```

Description

Run a UNIX shell command for a satellite device from the aggregation device in a Junos Fusion.

Options

- fpc fpc-slot*** Run the shell command on the satellite device using the specified FPC slot identifier only.
- range*** Run the shell command on the satellite devices in the specified range of FPC slot identifiers only.
- For instance, you can run the shell command on the satellite devices in FPC slot identifiers 101, 102, and 103 by entering a *range* of 101-103.
- remote-command*** Specify the UNIX shell command to run on the satellite device or devices.

Required Privilege Level

system-control

Release Information

Command introduced in Junos OS Release 14.2R3.

RELATED DOCUMENTATION

[Configuring or Expanding a Junos Fusion Enterprise](#)

Configuring Junos Fusion Provider Edge

request system software add (Junos OS)

IN THIS SECTION

- [Syntax | 206](#)
- [Syntax \(EX Series Switches\) | 206](#)
- [Syntax \(TX Matrix Router\) | 207](#)
- [Syntax \(TX Matrix Plus Router\) | 207](#)
- [Syntax \(MX Series Router\) | 208](#)

- Syntax (QFX Series) | 208
- Syntax (OCX Series) | 209
- Description | 209
- Options | 210
- Additional Information | 215
- Required Privilege Level | 216
- Output Fields | 216
- Sample Output | 216
- Release Information | 222

Syntax

```
request system software add package-name
<best-effort-load>
<delay-restart>
<device-alias alias-name>
<force>
<no-copy>
<no-validate>
<re0 | re1>
<reboot>
<satellite slot-id>
<set [package-name1 package-name2]>
<unlink>
<upgrade-group [all | upgrade-group-name]>
<upgrade-with-config>
<satellite slot-id>
<validate>
<version version-string>
```

Syntax (EX Series Switches)

```
request system software add package-name
<best-effort-load>
<delay-restart>
```

```

<force>
<no-copy>
<no-validate>
<re0 | re1>
<reboot>
<set [package-name1 package-name2]>
<upgrade-with-config>
<validate>
<validate-on-host hostname>
<validate-on-routing-engine routing-engine>

```

Syntax (TX Matrix Router)

```

request system software add package-name
<best-effort-load>
<delay-restart>
<force>
<lcc number | scc>
<no-copy>
<no-validate>
<re0 | re1>
<reboot>
<set [package-name1 package-name2]>
<unlink>
<upgrade-with-config>
<validate>
<validate-on-host hostname>
<validate-on-routing-engine routing-engine>

```

Syntax (TX Matrix Plus Router)

```

request system software add package-name
<best-effort-load>
<delay-restart>
<force>
<lcc number | sfc number>
<no-copy>
<no-validate>
<re0 | re1>

```

```

<reboot>
<set [package-name1 package-name2]>
<unlink>
<upgrade-with-config>
<validate>
<validate-on-host hostname>
<validate-on-routing-engine routing-engine>

```

Syntax (MX Series Router)

```

request system software add package-name
<best-effort-load>
<delay-restart>
<device-alias alias-name>
<force>
<member member-id>
<no-copy>
<no-validate>
<re0 | re1>
<reboot>
<satellite slot-id>
<set [package-name1 package-name2]>
<upgrade-group [all | upgrade-group-name]>
<unlink>
<upgrade-with-config>
<validate>
<version version-string>
<validate-on-host hostname>
<validate-on-routing-engine routing-engine>

```

Syntax (QFX Series)

```

request system software add package-name
<best-effort-load>
<component all>
<delay-restart>
<force>
<force-host>
<no-copy>

```

```

<partition>
<reboot>
<unlink>
<upgrade-with-config>

```

Syntax (OCX Series)

```

request system software add package-name
<best-effort-load>
<delay-restart>
<force>
<force-host>
<no-copy>
<no-validate>
<reboot>
<unlink>
<upgrade-with-config>
<validate>

```

Description

Install a software package or bundle on the device.

We recommend that you always download the software image to **/var/tmp** only. On EX Series and QFX Series switches, you must use the **/var/tmp** directory. Other directories are not supported.

When you are upgrading to a different release of Junos OS, you usually use the `validate` option on this command. The `validate` option checks the candidate software against the current configuration of the device to ensure they are compatible. (Validate is the default behavior when the software package being added is a different release.) However, there are circumstances under which you cannot validate the running configuration in this way. One such circumstance is when you are upgrading to Junos OS with upgraded FreeBSD from Junos OS based on FreeBSD 6.1. Another such circumstance is when you are updating between different releases of Junos OS with upgraded FreeBSD, and the newest version of FreeBSD uses system calls that are not available in earlier versions of FreeBSD.

Therefore, you cannot use the `validate` option when upgrading to Junos Release 21.2R1, because this release runs on FreeBSD 12; previous releases with upgraded FreeBSD run either FreeBSD 10 or 11.

If you are upgrading between releases that cannot use direct validation, you need to specify one of the following on the `request system software add` operational mode command when you upgrade:

- The `no-validate` option—this option does not validate the software package against the current configuration. Therefore, the current configuration might fail once you upgrade the system. Choose this option for the first time you upgrade a system to the newer version.
- The `validate-on-host` option—this option validates the software package by comparing it to the running configuration on a remote Junos OS host. Be sure to choose a host that you have already upgraded to the newer version of software.
- The `validate-on-routing-engine` option—(for systems with redundant REs) this option validates the software package by comparing it to the running configuration on a Routing Engine in the same chassis. Use this option when you have already upgraded the other Routing Engine to the newer version.

For information on valid filename and URL formats, see [Format for Specifying Filenames and URLs in Junos OS CLI Commands](#).

Any configuration changes performed after inputting the `request system software add` command will be lost when the system reboots with an upgraded version of Junos OS.

Starting from Junos OS Release 17.2R1, PTX10008 routers do not support the `request system software add` command. Starting from Junos OS Release 17.4R1, PTX10016 routers do not support the `request system software add` command. Use the `request vmhost software add` command instead of the `request system software add` command on the PTX10008 and PTX10016 routers to install or upgrade the Junos OS software package or bundle on the router. See [request vmhost software add](#).

When graceful Routing Engine switchover (GRES) is enabled on a device, you must perform a unified in-service software upgrade (ISSU) operation to update the software running on the device. With GRES enabled, if you attempt to perform a software upgrade by entering the `request system software add package-name` command, an error message is displayed stating that only in-service software upgrades are supported when GRES is configured. In such a case, you must either remove the GRES configuration before you attempt the upgrade or perform a unified ISSU.

Starting with Junos OS Release 15.1F3, the statement `request system software add` installs a software package for the guest OS only for the PTX5000 router with RE-DUO-C2600-16G, and for MX240, MX480, and MX960 routers with RE-S-1800X4-32G-S.

Starting with Junos OS Release 15.1F5, the statement `request system software add` installs a software package for the guest OS only for the MX2010 and MX2020 routers with REMX2K-1800-32G-S.

On these routers, in order to install both Junos software and host software packages, use the `request vmhost software add` command.

Options

package-name Location from which the software package or bundle is to be installed.

In Junos OS, *package-name* can be either the URL of a remote location or the pathname of a local package. But Junos OS Evolved does not support a remote iso for upgrade, so “URL” is removed from the help string in the CLI.

For example:

- ***/var/tmp/package-name***—For a software package or bundle that is being installed from a local directory on the router or switch.
- ***protocol://hostname/pathname/package-name***—For a software package or bundle that is to be downloaded and installed from a remote location. Replace *protocol* with one of the following:
 - **ftp**—File Transfer Protocol.
Use ***ftp://hostname/pathname/package-name***. To specify authentication credentials, use ***ftp://<username>:<password>@hostname/pathname/package-name***. To have the system prompt you for the password, specify prompt in place of the password. If a password is required, and you do not specify the password or prompt, an error message is displayed.
 - **http**—Hypertext Transfer Protocol.
Use ***http://hostname/pathname/package-name***. To specify authentication credentials, use ***http://<username>:<password>@hostname/pathname/package-name***. If a password is required and you omit it, you are prompted for it.
 - **scp**—Secure copy (not available for limited editions).
Use ***scp://hostname/pathname/package-name***. To specify authentication credentials, use ***scp://<username>:<password>@hostname/pathname/package-name***.
- The *pathname* in the protocol is the relative path to the user’s home directory on the remote system and not the root directory.
- Do not use the **scp** protocol in the `request system software add` command to download and install a software package or bundle from a remote location. The previous statement does not apply to the QFabric switch. The software upgrade is handled by the management process (mgd), which does not support scp.
Use the `file copy` command to copy the software package or bundle from the remote location to the `/var/tmp` directory on the hard disk:
`file copy scp://source/package-name /var/tmp`
Then install the software package or bundle using the `request system software add` command:
`request system software add /var/tmp/package-name`

best-effort-load	(Optional) Activate a partial load and treat parsing errors as warnings instead of errors.
component all	(QFabric systems only) (Optional) Install the software package on all of the QFabric components.
delay-restart	(Optional) Install a software package or bundle, but do not restart software processes.
device-alias <i>alias-name</i>	(Junos Fusion only) (Optional) Install the satellite software package onto the specified satellite device using the satellite device's alias name.
force	(Optional) Force the addition of the software package or bundle (ignore warnings).
force-host	(Optional) Force the addition of the host software package or bundle (ignore warnings) on the QFX5100 device.
lcc <i>number</i>	<p>(TX Matrix routers and TX Matrix Plus routers only) (Optional) In a routing matrix based on the TX Matrix router, install a software package or bundle on a T640 router that is connected to the TX Matrix router. In a routing matrix based on the TX Matrix Plus router, install a software package or bundle on a router that is connected to the TX Matrix Plus router.</p> <p>Replace <i>number</i> with the following values depending on the LCC configuration:</p> <ul style="list-style-type: none"> • 0 through 3, when T640 routers are connected to a TX Matrix router in a routing matrix. • 0 through 3, when T1600 routers are connected to a TX Matrix Plus router in a routing matrix. • 0 through 7, when T1600 routers are connected to a TX Matrix Plus router with 3D SIBs in a routing matrix. • 0, 2, 4, or 6, when T4000 routers are connected to a TX Matrix Plus router with 3D SIBs in a routing matrix.
member <i>member-id</i>	(MX Series routers only) (Optional) Install a software package on the specified Virtual Chassis member. Replace <i>member-id</i> with a value of 0 or 1.
partition	(QFX3500 switches only) (Optional) Format and repartition the media before installation.
satellite <i>slot-id</i>	(Junos Fusion only) (Optional) Install the satellite software package onto the specified satellite device using the satellite devices FPC slot identifier.

scc	(TX Matrix routers only) (Optional) Install a software package or bundle on a Routing Engine on a TX Matrix router (or switch-card chassis).
sfc <i>number</i>	(TX Matrix Plus routers only) (Optional) Install a software package or bundle on a Routing Engine on a TX Matrix Plus router. Replace <i>number</i> with 0.
no-copy	(Optional) Install a software package or bundle, but do not save copies of the package or bundle files.
no-validate	<p>(Optional) When loading a software package or bundle with a different release, suppress the default behavior of the <code>validate</code> option.</p> <p>To upgrade to Junos OS Release 21.2R1, you cannot use the <code>validate</code> option. Instead, choose one of the following options:</p> <ul style="list-style-type: none"> • <code>no-validate</code> • <code>validate-on-host</code> • <code>validate-on-routing-engine</code> <p>Software packages from unidentified providers cannot be loaded. To authorize providers, include the <code>provider-id</code> statement at the <code>[edit system extensions provider]</code> hierarchy level.</p>
re0 re1	(Optional) On routers or switches that support dual or redundant Routing Engines, load a software package or bundle on the Routing Engine in slot 0 (re0) or the Routing Engine in slot 1 (re1).
reboot	(Optional) After adding the software package or bundle, reboot the system. On a QFabric switch, the software installation is not complete until you reboot the component for which you have installed the software.
set [<i>package-name1</i> <i>package-name2</i>]	<p>(Mixed EX4200 and EX4500 Virtual Chassis, M Series, MX Series, and T Series routers only) (Optional) Install multiple packages at same time:</p> <ul style="list-style-type: none"> • In the case of mixed EX4200 and EX4500 Virtual Chassis, install two software packages—a package for an EX4200 switch and the same release of the package for an EX4500 switch—to upgrade all member switches in a mixed EX4200 and EX4500 Virtual Chassis. • In the case of M Series, MX Series, and T Series routers, install multiple (two or more) software packages and software add-on packages at the same time. The variable <i>package-name</i> can either be a list of installation packages, each

separated by a blank space, or the full URL to the directory or tar file containing the list of installation packages.

In each case, *installation-package* can either be a list of installation packages, each separated by a blank space, or the full URL to the directory or tar file containing the list of installation packages.

Use the request system software add set command to retain any SDK configuration by installing the SDK add-on packages along with the core Junos OS installation package.

unlink

(Optional) On M Series, T Series, and MX Series routers, use the unlink option to remove the software package from this directory after a successful upgrade is completed.

upgrade-group [all |*upgrade-group- name*]

(Junos Fusion only) (Required to configure a Junos Fusion using autoconversion or manual conversion) Associate a satellite software image with a satellite software upgrade group. The satellite software package is associated with the specified satellite software upgrade group using the *upgrade-group-name*, or for all satellite software upgrade groups in a Junos Fusion when the all keyword is specified.

A satellite software upgrade group is a group of satellite devices in a Junos Fusion that are designated to upgrade to the same satellite software version using the same satellite software package. See , [Understanding Software in a Junos Fusion Provider Edge](#) "Understanding Software in a Junos Fusion Enterprise" on page 25, and ["Managing Satellite Software Upgrade Groups in a Junos Fusion" on page 154.](#)

upgrade-with- config

(Optional) Install one or more configuration files.

Configuration files specified with this option must have the extension **.text** or **.xml** and have the extension specified. Using the extension **.txt** will not work.

validate

(Optional) Validate the software package or bundle against the current configuration as a prerequisite to adding the software package or bundle. This is the default behavior when the software package or bundle being added is a different release.

To upgrade to Junos OS Release 21.2R1, you cannot use the validate option. Instead, choose one of the following options:

- no-validate
- validate-on-host
- validate-on-routing-engine

The `validate` option only works on systems that do not have `graceful-switchover` (*GRES*) enabled. To use the `validate` option on a system with *GRES*, either disable *GRES* for the duration of the installation, or install using the command `request system software in-service-upgrade`, which requires nonstop active routing (*NSR*) to be enabled when using *GRES*.

validate-on-host <i>hostname</i>	(Optional) Validate the software package by comparing it to the running configuration on a remote Junos OS host. Specify a host, replacing <i>hostname</i> with the remote hostname. You can optionally provide the username that will be used to log in to the remote host by specifying the hostname in the format <code>user@hostname</code> .
validate-on-routing-engine <i>routing-engine</i>	(Optional) Validate the software bundle or package by comparing it to the running configuration on a Junos OS Routing Engine on the same chassis. Specify a Routing Engine, replacing <i>routing-engine</i> with the routing engine name.

Additional Information

Before upgrading the software on the router or switch, when you have a known stable system, issue the `request system snapshot` command to back up the software, including the configuration, to the `/altroot` and `/altconfig` file systems. After you have upgraded the software on the router or switch and are satisfied that the new package or bundle is successfully installed and running, issue the `request system snapshot` command again to back up the new software to the `/altroot` and `/altconfig` file systems.

The `request system snapshot` command is currently not supported on the QFabric system. Also, you cannot add or install multiple packages on a QFabric system.

After you run the `request system snapshot` command, you cannot return to the previous version of the software because the running and backup copies of the software are identical.

If you are upgrading more than one package at the same time, delete the operating system package, `jkernl`, last. Add the operating system package, `jkernl`, first and the routing software package, `jroute`, last. If you are upgrading all packages at once, delete and add them in the following order:

```

user@host> request system software add /var/tmp/jbase
user@host> request system software add /var/tmp/jkernel
user@host> request system software add /var/tmp/jpfe
user@host> request system software add /var/tmp/jdocs
user@host> request system software add /var/tmp/jroute
user@host> request system software add /var/tmp/jcrypto

```

By default, when you issue the `request system software add package-name` command on a TX Matrix primary Routing Engine, all the T640 primary Routing Engines that are connected to it are upgraded to the same

version of software. If you issue the same command on the TX Matrix backup Routing Engine, all the T640 backup Routing Engines that are connected to it are upgraded to the same version of software.

Likewise, when you issue the request `system software add package-name` command on a TX Matrix Plus primary Routing Engine, all the T1600 or T4000 primary Routing Engines that are connected to it are upgraded to the same version of software. If you issue the same command on the TX Matrix Plus backup Routing Engine, all the T1600 or T4000 backup Routing Engines that are connected to it are upgraded to the same version of software.

Before installing software on a device that has one or more custom YANG data models added to it, back up and remove the configuration data corresponding to the custom YANG data models from the active configuration. For more information see [Managing YANG Packages and Configurations During a Software Upgrade or Downgrade](#).

Required Privilege Level

maintenance

Output Fields

When you enter this command, you are provided feedback on the status of your request.

Sample Output

request system software add validate

```
user@host> request system software add validate /var/tmp/ jinstall-7.2R1.7-domestic-signed.tgz
Checking compatibility with configuration
Initializing...
Using jbase-7.1R2.2
Using /var/tmp/jinstall-7.2R1.7-domestic-signed.tgz
Verified jinstall-7.2R1.7-domestic.tgz signed by PackageProduction_7_2_0
Using /var/validate/tmp/jinstall-signed/jinstall-7.2R1.7-domestic.tgz
Using /var/validate/tmp/jinstall/jbundle-7.2R1.7-domestic.tgz
Checking jbundle requirements on /
Using /var/validate/tmp/jbundle/jbase-7.2R1.7.tgz
Using /var/validate/tmp/jbundle/jkernel-7.2R1.7.tgz
Using /var/validate/tmp/jbundle/jcrypto-7.2R1.7.tgz
Using /var/validate/tmp/jbundle/jpfe-7.2R1.7.tgz
Using /var/validate/tmp/jbundle/jdocs-7.2R1.7.tgz
Using /var/validate/tmp/jbundle/jroute-7.2R1.7.tgz
Validating against /config/juniper.conf.gz
```

```

mgd: commit complete
Validation succeeded
Validating against /config/rescue.conf.gz
mgd: commit complete
Validation succeeded
Installing package '/var/tmp/jinstall-7.2R1.7-domestic-signed.tgz' ...
Verified jinstall-7.2R1.7-domestic.tgz signed by PackageProduction_7_2_0
Adding jinstall...

```

```

WARNING:      This package will load JUNOS 7.2R1.7 software.
WARNING:      It will save JUNOS configuration files, and SSH keys
WARNING:      (if configured), but erase all other files and information
WARNING:      stored on this machine. It will attempt to preserve dumps
WARNING:      and log files, but this can not be guaranteed. This is the
WARNING:      pre-installation stage and all the software is loaded when
WARNING:      you reboot the system.

```

```

Saving the config files ...
Installing the bootstrap installer ...

```

```

WARNING:      A REBOOT IS REQUIRED TO LOAD THIS SOFTWARE CORRECTLY. Use the
WARNING:      'request system reboot' command when software installation is
WARNING:      complete. To abort the installation, do not reboot your system,
WARNING:      instead use the 'request system software delete jinstall'
WARNING:      command as soon as this operation completes.

```

```

Saving package file in /var/sw/pkg/jinstall-7.2R1.7-domestic-signed.tgz ...
Saving state for rollback ...

```

request system software add /var/tmp/ no-validate

```

user@host> request system software add no-validate /var/tmp/junos-install-mx-x86-32-15.1R1.9.tgz
Installing package '/var/tmp/junos-install-mx-x86-32-15.1R1.9.tgz' ...
Verified manifest signed by PackageProductionEc_2015
Verified manifest signed by PackageProductionRSA_2015
Verified contents.iso
Verified issu-indb.tgz
Verified junos-x86-32.tgz
Verified kernel
Verified metatags
Verified package.xml

```

```

Verified pkgtools.tgz
camcontrol: not found
camcontrol: not found
Verified manifest signed by PackageProductionEc_2015
Saving the config files ...
NOTICE: uncommitted changes have been saved in /var/db/config/juniper.conf.pre-install
Saving package file in /var/sw/pkg/junos-install-x86-32-
domestic-20150618.043753_builder_junos_151_r1.tgz ...
Saving state for rollback ...

```

request system software add no-copy no-validate reboot

```

user@host> request system software add no-copy no-validate junos-install-srx-x86-64-17.3R1.tgz
reboot
Verified junos-install-srx-x86-64-17.3R1 signed by PackageProductionEc_2017 method
ECDSA256+SHA256
Verified manifest signed by PackageProductionEc_2017 method ECDSA256+SHA256
Checking PIC combinations
Verified fips-mode signed by PackageProductionEc_2017 method ECDSA256+SHA256
Adding fips-mode-x86-32-20170728.153050_builder_junos_173_r1 ...
Verified jail-runtime signed by PackageProductionEc_2017 method ECDSA256+SHA256
Adding jail-runtime-x86-32-20170725.352915_builder_stable_10 ...
Verified jdocs signed by PackageProductionEc_2017 method ECDSA256+SHA256
Adding jdocs-x86-32-20170728.153050_builder_junos_173_r1 ...
Verified jfirmware signed by PackageProductionEc_2017 method ECDSA256+SHA256
Adding jfirmware-x86-32-17.3R1 ...
Verified jpfe-X signed by PackageProductionEc_2017 method ECDSA256+SHA256
Adding jpfe-X-x86-32-20170728.153050_builder_junos_173_r1 ...
Verified jpfe-X960 signed by PackageProductionEc_2017 method ECDSA256+SHA256
Adding jpfe-X960-x86-32-20170728.153050_builder_junos_173_r1 ...
Verified jpfe-common signed by PackageProductionEc_2017 method ECDSA256+SHA256
Adding jpfe-common-x86-32-20170728.153050_builder_junos_173_r1 ...
Verified jpfe-fips signed by PackageProductionEc_2017 method ECDSA256+SHA256
Verified jpfe-wrlinux signed by PackageProductionEc_2017 method ECDSA256+SHA256
Adding jpfe-wrlinux-x86-32-20170728.153050_builder_junos_173_r1 ...
Verified jsd-jet-1 signed by PackageProductionEc_2017 method ECDSA256+SHA256
Adding jsd-x86-32-17.3R1-jet-1 ...

```

request system software add validate-on-host

```
user@host> request system software add validate-on-host user@xyz :/var/tmp/
jinstall-15.1-20150516_ib_15_2_psd.0-domestic-signed.tgz
user@host> request system software add validate-on-host user@xyz :/var/tmp/
jinstall-15.1-20150516_ib_15_2_psd.0-domestic-signed.tgz
Extracting JUNOS version from package...
Connecting to remote host xyz...
Password:
Sending configuration to xyz...
Validating configuration on xyz...
PACKAGETYPE: not found
Checking compatibility with configuration
Initializing...
Using jbase-15.1-20150516_ib_15_2_psd.0
Verified manifest signed by PackageDevelopmentEc_2015
Using jruntime-15.1-20150516_ib_15_2_psd.0
Verified manifest signed by PackageDevelopmentEc_2015
Using jkernel-15.1-20150516_ib_15_2_psd.0
Verified manifest signed by PackageDevelopmentEc_2015
Using jroute-15.1-20150516_ib_15_2_psd.0
Verified manifest signed by PackageDevelopmentEc_2015
Using jcrypto-15.1-20150516_ib_15_2_psd.0
Verified manifest signed by PackageDevelopmentEc_2015
Using jweb-15.1-20150516_ib_15_2_psd.0
Verified manifest signed by PackageDevelopmentEc_2015
Using /var/packages/jtools-15.1-20150516_ib_15_2_psd.0
Verified manifest signed by PackageDevelopmentEc_2015
Using /var/tmp/config.tgz
Hardware Database regeneration succeeded
Validating against /config/juniper.conf.gz
mgd: warning: schema: init: 'logical-systems-vlans' contains-node 'juniper-config vlans': not
found
mgd: commit complete
Validation succeeded
Installing package '/var/tmp/jinstall-15.1-20150516_ib_15_2_psd.0-domestic-signed.tgz' ...
Verified jinstall-15.1-20150516_ib_15_2_psd.0-domestic.tgz signed by PackageDevelopmentEc_2015
Adding jinstall...

WARNING:    The software that is being installed has limited support.
WARNING:    Run 'file show /etc/notices/unsupported.txt' for details.
```

```

WARNING: This package will load JUNOS 15.1-20150516_ib_15_2_psd.0 software.
WARNING: It will save JUNOS configuration files, and SSH keys
WARNING: (if configured), but erase all other files and information
WARNING: stored on this machine. It will attempt to preserve dumps
WARNING: and log files, but this can not be guaranteed. This is the
WARNING: pre-installation stage and all the software is loaded when
WARNING: you reboot the system.

```

```
Saving the config files ...
```

```
NOTICE: uncommitted changes have been saved in /var/db/config/juniper.conf.pre-install
```

```
Installing the bootstrap installer ...
```

```

WARNING: A REBOOT IS REQUIRED TO LOAD THIS SOFTWARE CORRECTLY. Use the
WARNING: 'request system reboot' command when software installation is
WARNING: complete. To abort the installation, do not reboot your system,
WARNING: instead use the 'request system software delete jinstall'
WARNING: command as soon as this operation completes.

```

```
Saving package file in /var/sw/pkg/jinstall-15.1-20150516_ib_15_2_psd.0-domestic-signed.tgz ...
```

```
Saving state for rollback ...
```

request system software add (Mixed EX4200 and EX4500 Virtual Chassis)

```

user@switch> request system software add set [/var/tmp/jinstall-ex-4200-11.1R1.1-domestic-
signed.tgz /var/tmp/jinstall-ex-4500-11.1R1.1-domestic-signed.tgz]
...

```

request system software add component all (QFabric Systems)

```

user@switch> request system software add /pbdata/packages/jinstall-qfabric-12.2X50-D1.3.rpm
component all
...

```

request system software add upgrade-group (Junos Fusion)

```
user@aggregation-device> request system software add /var/tmp/satellite-3.0R1.1-signed.tgz
upgrade-group group1
```

request system software add no-validate (SRX Series device)

```
user@host> request system software add /var/tmp/junos-
srxsme-20.4I-20200810_dev_common.0.0833.tgz no-copy no-validate
Formatting alternate root (/dev/ad0s2a)...
/dev/ad0s2a: 600.0MB (1228732 sectors) block size 16384, fragment size 2048
    using 4 cylinder groups of 150.00MB, 9600 blks, 19200 inodes.
super-block backups (for fsck -b #) at:
32, 307232, 614432, 921632
Installing package '/altroot/cf/packages/install-tmp/junos-20.4I-20200810_dev_common.0.0833' ...
Verified junos-boot-srxsme.tgz signed by PackageDevelopmentECP256_2020 method ECDSA256+SHA256
Verified junos-srxsme-domestic signed by PackageDevelopmentECP256_2020 method ECDSA256+SHA256
Verified manifest signed by PackageDevelopmentECP256_2020 method ECDSA256+SHA256

WARNING:    The software that is being installed has limited support.
WARNING:    Run 'file show /etc/notices/unsupported.txt' for details.

JUNOS 20.4I-20200810_dev_common.0.0833 will become active at next reboot
WARNING: A reboot is required to load this software correctly
WARNING:    Use the 'request system reboot' command
WARNING:    when software installation is complete
Saving state for rollback ...

user@host> request system software add /var/tmp/junos-srxsme-19.4R1.3.tgz no-copy no-validate
WARNING: Package junos-19.4R1.3 version 19.4R1.3 is not compatible with current loader
WARNING: Automatic recovering loader, please wait ...
Upgrading Loader...
#####
Verifying the loader image... OK
WARNING: The new boot firmware will take effect when the system is rebooted.
WARNING: Loader recover finish.
Formatting alternate root (/dev/ad0s1a)...
/dev/ad0s1a: 598.5MB (1225692 sectors) block size 16384, fragment size 2048
    using 4 cylinder groups of 149.62MB, 9576 blks, 19200 inodes.
super-block backups (for fsck -b #) at:
```



```

32, 306464, 612896, 919328
Installing package '/altroot/cf/packages/install-tmp/junos-19.4R1.3' ...
Verified junos-boot-srxsme-19.4R1.3.tgz signed by PackageProductionEc_2019 method
ECDSA256+SHA256
Verified junos-srxsme-19.4R1.3-domestic signed by PackageProductionEc_2019 method
ECDSA256+SHA256
Verified junos-boot-srxsme-19.4R1.3.tgz signed by PackageProductionEc_2019 method
ECDSA256+SHA256 V
erified junos-srxsme-19.4R1.3-domestic signed by PackageProductionEc_2019 method ECDSA256+SHA256
JUNOS 19.4R1.3 will become active at next reboot
WARNING: A reboot is required to load this software correctly
WARNING: Use the 'request system reboot' command
WARNING: when software installation is complete Saving state for rollback ...

```

request system software add (SRX Series device)

```

user@host> request system software add /var/tmp/junos-srxsme-19.4R2.3.tgz
WARNING: Package junos-19.4R2.3 version 19.4R2.3 is not compatible with this system.
WARNING: Please install a package with veloadr support, 20.3 or higher.

```

Release Information

Command introduced before Junos OS Release 7.4.

best-effort-load and unlink options added in Junos OS Release 7.4.

sfc option introduced in Junos OS Release 9.6 for the TX Matrix Plus router.

set [*package-name1package-name2*] option added in Junos OS Release 11.1 for EX Series switches. Added in Junos OS Release 12.2 for M Series, MX Series, and T Series routers.

On EX Series switches, the set [*package-name1package-name2*] option allows you to install only two software packages on a mixed EX4200 and EX4500 Virtual Chassis. Whereas, on M Series, MX Series, and T Series routers, the set [*package-name1package-name2package-name3*] option allows you to install multiple software packages and software add-on packages at the same time.

upgrade-with-config and upgrade-with-config-format *format* options added in Junos OS Release 12.3 for M Series routers, MX Series routers, and T Series routers, EX Series Ethernet switches, and QFX Series devices.

device-alias, satellite, upgrade-group, and version options introduced in Junos OS Release 14.2R3 for Junos Fusion.

validate-on-host and validate-on-routing-engine options added in Junos OS Release 15.1F3 for PTX5000 routers and MX240, MX480, and MX960 routers.

upgrade-with-config-format *format* option deleted in Junos OS Release 16.1 for M Series routers, MX Series routers, and T Series routers, EX Series Ethernet switches, and QFX Series devices.

RELATED DOCUMENTATION

Format for Specifying Filenames and URLs in Junos OS CLI Commands

request system software rollback

request system storage cleanup

Installing Software Packages on QFX Series Devices (Junos OS)

Upgrading Software on a QFabric System

[Managing Satellite Software Upgrade Groups in a Junos Fusion | 154](#)

request system software add (Maintenance)

[Routing Matrix with a TX Matrix Plus Router Solutions Page](#)

request system software delete (Junos OS)

IN THIS SECTION

- [Syntax | 224](#)
- [Syntax \(TX Matrix Router\) | 224](#)
- [Description | 224](#)
- [Options | 224](#)
- [Additional Information | 226](#)
- [Required Privilege Level | 226](#)
- [Output Fields | 226](#)
- [Sample Output | 227](#)
- [Release Information | 228](#)

Syntax

```
request system software delete software-package
<force>
<reboot>
<set [package-name package-name]>
<upgrade-group [all | upgrade-group-name]>
<version version-string>
```

Syntax (TX Matrix Router)

```
request system software delete software-package
<force>
<lcc number | scc>
<reboot>
<set [package-name package-name]>
```

Description

Use this command to remove a software package or bundle from the device.



CAUTION: Before removing a software package or bundle, make sure that you have already placed the new software package or bundle that you intend to load onto the device.

Options

software-package

Software package or bundle name. You can see this software package name by using the `show system software` command. Type the software package name explicitly and do not use the tab key to auto-complete the command.

You can delete any or all of the following software bundles or packages:

- `jbase`—(Optional) Junos base software suite
- `jcrypto`—(Optional, in domestic version only) Junos security software
- `jdocs`—(Optional) Junos online documentation file

- `jkernel`—(Optional) Junos kernel software suite
- `jpfe`—(Optional) Junos Packet Forwarding Engine support
- `jroute`—(Optional) Junos routing software suite
- `junos`—(Optional) Junos base software

On EX Series switches, some of the package names are different than those listed. To see the list of packages that you can delete on an EX Series switch, enter the command **show system software**.

force (Optional) Ignore warnings and force removal of the software.

lcc number (TX Matrix routers and TX Matrix Plus routers only) (Optional) In a routing matrix, delete a software package or bundle on a T640 router indicated by `lcc number` that is connected to the TX Matrix router. In a routing matrix, delete a software package or bundle on a router indicated by `lcc number` that is connected to the TX Matrix Plus router.

Replace *number* with the following values depending on the LCC configuration:

- 0 through 3, when T640 routers are connected to a TX Matrix router in a routing matrix.
- 0 through 3, when T1600 routers are connected to a TX Matrix Plus router in a routing matrix.
- 0 through 7, when T1600 routers are connected to a TX Matrix Plus router with 3D SIBs in a routing matrix.
- 0, 2, 4, or 6, when T4000 routers are connected to a TX Matrix Plus router with 3D SIBs in a routing matrix.

re0 | re1 (Optional) On routers or switches that support dual or redundant Routing Engines, delete a software package or bundle on the Routing Engine in slot 0 (re0) or the Routing Engine in slot 1 (re1).

reboot As of Junos OS 12.3 and greater, automatically reboot upon completing the request `system software delete` command.

scc (TX Matrix routers only) (Optional) Remove an extension or upgrade package from the TX Matrix router (or switch-card chassis).

set [*package-name package-name*] (M Series, MX Series, and T Series routers only) (Optional) Install multiple software packages or software add-on packages at the same time.

<i>sfc number</i>	(TX Matrix Plus routers only) (Optional) Remove an extension or upgrade package from the TX Matrix Plus router. Replace <i>number</i> with 0.
<i>upgrade-group [all upgrade-group-name]</i>	(Junos Fusion only) Delete the satellite software image association with the specified satellite software upgrade group. A satellite software upgrade group is a group of satellite devices in the same Junos Fusion that are designated to upgrade to the same satellite software version using the same satellite software package.
<i>version version-string</i>	(Junos Fusion only) (Optional) Delete a satellite software package association with a satellite software upgrade group by selecting the satellite software package's version.

Additional Information

Before upgrading the software on the router or switch, when you have a known stable system, issue the `request system snapshot` command to back up the software, including the configuration, to the `/altroot` and `/altconfig` file systems (on routers) or the `/`, `/altroot`, `/config`, `/var`, and `/var/tmp` file systems (on switches). After you have upgraded the software on the router or switch and are satisfied that the new packages are successfully installed and running, issue the `request system snapshot` command again to back up the new software to the `/altroot` and `/altconfig` file systems (on routers) or the `/`, `/altroot`, `/config`, `/var`, and `/var/tmp` file systems (on switches). After you run the `request system snapshot` command, you cannot return to the previous version of the software, because the running and backup copies of the software are identical.

Required Privilege Level

maintenance

Output Fields

When you enter this command, you are provided feedback on the status of your request.

Sample Output

request system software delete jdocs

The following example displays the system software packages before and after the jdocs package is deleted through the request system software delete command:

```
user@host> show system software
Information for jbase:

Comment:
JUNOS Base OS Software Suite [7.2R1.7]

Information for jcrypto:

Comment:
JUNOS Crypto Software Suite [7.2R1.7]

Information for jdocs:

Comment:
JUNOS Online Documentation [7.2R1.7]

Information for jkernel:

Comment:
JUNOS Kernel Software Suite [7.2R1.7]

...

user@host> show system software
Information for jbase:

Comment:
JUNOS Base OS Software Suite [7.2R1.7]

Information for jcrypto:
```

```
Comment:
JUNOS Crypto Software Suite [7.2R1.7]
```

```
Information for jkernel:
```

```
Comment:
JUNOS Kernel Software Suite [7.2R1.7]
```

```
...
```

Release Information

Command introduced before Junos OS Release 7.4.

sfc option introduced in Junos OS Release 9.6 for the TX Matrix Plus router.

set [*package-name package-name*] option added in Junos OS Release 12.2 for M Series, MX Series, and T Series routers.

reboot option introduced in Junos OS Release 12.3.

upgrade-group, and version options introduced in Junos OS Release 14.2R3 for Junos Fusion.

RELATED DOCUMENTATION

[request system software add \(Junos OS\) | 205](#)

[request system software rollback \(Junos OS\) | 228](#)

[Routing Matrix with a TX Matrix Plus Router Solutions Page](#)

request system software rollback (Junos OS)

IN THIS SECTION

- [Syntax | 229](#)
- [Syntax \(EX Series Switches\) | 229](#)

- [Syntax \(TX Matrix Router\) | 229](#)
- [Syntax \(TX Matrix Plus Router\) | 230](#)
- [Syntax \(MX Series Router\) | 230](#)
- [Description | 230](#)
- [Options | 231](#)
- [Required Privilege Level | 232](#)
- [Output Fields | 232](#)
- [Sample Output | 232](#)
- [Release Information | 233](#)

Syntax

```
request system software rollback
```

Syntax (EX Series Switches)

```
request system software rollback  
<all-members>  
<local>  
<member member-id>  
<reboot>
```

Syntax (TX Matrix Router)

```
request system software rollback  
<lcc number | scc>  
<reboot>
```

Syntax (TX Matrix Plus Router)

```
request system software rollback
<lcc number | sfc number>
<reboot>
```

Syntax (MX Series Router)

```
request system software rollback
<all-members>
<device-alias alias-name>
<local>
<member member-id>
<reboot>
<satellite slot-id>
<upgrade-group [all | upgrade-group-name]>
```

Description

Use this command to revert to the last successfully installed package before the `request system software (add | delete)` command. It uses the copy stored in the `/var/sw/pkg` directory.

Additional Information

- On Junos Fusion, the `request system software rollback` command can be used to roll back the version of satellite software associated with a satellite software upgrade group. Rolling back the version of satellite software associated with a satellite software upgrade group triggers a satellite software upgrade.
- On M Series and T Series routers, if `request system software add <jinstall> reboot` was used for the previous installation, then `request system software rollback` has no effect. In this case, use `jinstall` to reinstall the required package.
- On M Series and T Series routers, if `request system software add <sdk1>` was used for the previous installation, then `request system software rollback` removes the last installed SDK package (`sdk1` in this example).
- On SRX Series devices with dual root systems, when `request system software rollback` is run, the system switches to the alternate root. Each root can have a different version of Junos OS. Roll back takes each root back to the previously installed image.

- On QFX3500 and QFX3600 devices in a mixed Virtual Chassis, when the `request system software rollback` command is issued, the system does not rollback to the image stored in the alternate partition.
- On QFX5100 switches, the `reboot` option has been removed. To reboot the switch after a software rollback, issue the `request system reboot` command as a separate, secondary command.

Options

all-members	(EX4200 switches and MX Series routers only) (Optional) Attempt to roll back to the previous set of packages on all members of the Virtual Chassis configuration.
device-alias alias-name	(Junos Fusion only) (Optional) Rollback the satellite software package onto the specified satellite device using the satellite devices FPC slot identifier.
lcc number	(TX Matrix routers and TX Matrix Plus routers only) (Optional) On a TX Matrix router, attempt to roll back to the previous set of packages on a T640 router connected to the TX Matrix router. On a TX Matrix Plus router, attempt to roll back to the previous set of packages on a connected router connected to the TX Matrix Plus router. Replace <i>number</i> with the following values depending on the LCC configuration: <ul style="list-style-type: none"> • 0 through 3, when T640 routers are connected to a TX Matrix router in a routing matrix. • 0 through 3, when T1600 routers are connected to a TX Matrix Plus router in a routing matrix. • 0 through 7, when T1600 routers are connected to a TX Matrix Plus router with 3D SIBs in a routing matrix. • 0, 2, 4, or 6, when T4000 routers are connected to a TX Matrix Plus router with 3D SIBs in a routing matrix.
local	(EX4200 switches and MX Series routers only) (Optional) Attempt to roll back to the previous set of packages on the local Virtual Chassis member.
member member-id	(EX4200 switches and MX Series routers only) (Optional) Attempt to roll back to the previous set of packages on the specified member of the Virtual Chassis configuration. For EX4200 switches, replace <i>member-id</i> with a value from 0 through 9. For an MX Series Virtual Chassis, replace <i>member-id</i> with a value of 0 or 1.
none	For all versions of Junos OS up to and including Junos OS 11.4, revert to the set of software as of the last successful <code>request system software add</code> . As of Junos OS 12.1 and

later, revert to the last known good state before the most recent request system software (add | delete) command.

reboot	(Optional) For Junos OS 12.3 and later, the system reboots automatically to complete the rollback. However, for Junos OS Evolved, you must explicitly specify the reboot option to complete the rollback.
satellite <i>slot-id</i>	(Junos Fusion only) (Optional) Roll back the satellite software package onto the specified satellite device using the satellite devices FPC slot identifier.
scc	(TX Matrix routers only) (Optional) Attempt to roll back to the previous set of packages on the TX Matrix router (or switch-card chassis).
sfc <i>number</i>	(TX Matrix Plus routers only) (Optional) Attempt to roll back to the previous set of packages on the TX Matrix Plus router. Replace <i>number</i> with 0.
upgrade-group [all <i>upgrade-group-name</i>]	(Junos Fusion only) Roll back the satellite software image associated with the specified satellite software upgrade group, or for all satellite software upgrade groups in the Junos Fusion when all is entered.

Required Privilege Level

maintenance

Output Fields

When you enter this command, you are provided feedback on the status of your request.

Sample Output

request system software rollback

```
user@host> request system software rollback
Verified SHA1 checksum of ./jbase-7.2R1.7.tgz
Verified SHA1 checksum of ./jdocs-7.2R1.7.tgz
Verified SHA1 checksum of ./jroute-7.2R1.7.tgz
Installing package './jbase-7.2R1.7.tgz' ...
Available space: 35495 require: 7335
Installing package './jdocs-7.2R1.7.tgz' ...
Available space: 35339 require: 3497
Installing package './jroute-7.2R1.7.tgz' ...
```

```
Available space: 35238 require: 6976
NOTICE: uncommitted changes have been saved in /var/db/config/juniper.conf.pre-install
Reloading /config/juniper.conf.gz ...
Activating /config/juniper.conf.gz ...
mgd: commit complete
Restarting mgd ...
Restarting aprobed ...
Restarting apsd ...
Restarting cosd ...
Restarting fsad ...
Restarting fud ...
Restarting gcdrd ...
Restarting ilmid ...
Restarting irsd ...
Restarting l2tpd ...
Restarting mib2d ...
Restarting nasd ...
Restarting pppoed ...
Restarting rdd ...
Restarting rmopd ...
Restarting rtspd ...
Restarting sampled ...
Restarting serviced ...
Restarting snmpd ...
Restarting spd ...
Restarting vrrpd ...

WARNING: cli has been replaced by an updated version:
CLI release 7.2R1.7 built by builder on 2005-04-22 02:03:44 UTC
Restart cli using the new version ? [yes,no] (yes) yes

Restarting cli ...
user@host
```

Release Information

Command introduced before Junos OS Release 7.4.

sfc option introduced in Junos OS Release 9.6 for the TX Matrix Plus router.

Command behavior changed in Junos OS Release 12.1.

reboot option introduced in Junos OS Release 12.3.

device-alias, satellite, and upgrade-group options introduced in Junos OS Release 14.2R3 for Junos Fusion.

force option deprecated in Junos OS Release 15.1 for Junos OS with Upgraded FreeBSD.

To determine which platforms run Junos OS with Upgraded FreeBSD, see the table listing the platforms currently running Junos OS with upgraded FreeBSD in [Release Information for Junos OS with Upgraded FreeBSD](#).

RELATED DOCUMENTATION

[request system software delete \(Junos OS\) | 223](#)

request system configuration rescue delete

request system configuration rescue save

[Routing Matrix with a TX Matrix Plus Router Solutions Page](#)

request system storage cleanup (Junos OS)

IN THIS SECTION

- [Syntax | 235](#)
- [Syntax \(EX Series Switches\) | 235](#)
- [Syntax \(MX Series Router\) | 235](#)
- [Syntax \(QFX Series\) | 235](#)
- [Syntax \(SRX Series\) | 236](#)
- [Description | 236](#)
- [Options | 236](#)
- [Additional Information | 238](#)
- [Required Privilege Level | 238](#)
- [Output Fields | 238](#)
- [Sample Output | 239](#)
- [Release Information | 248](#)

Syntax

```
request system storage cleanup
<dry-run>
<no-confirm>
<re0 | re1 | routing-engine (backup | both | local | master | other)>
```

Syntax (EX Series Switches)

```
request system storage cleanup
<all-members>
<dry-run>
<local>
<member member-id>
<no-confirm>
<re0 | re1 | routing-engine (backup | both | local | master | other)>
<satellite [slot-id slot-id |device-alias alias-name]>
```

Syntax (MX Series Router)

```
request system storage cleanup
<all-members>
<dry-run>
<local>
<member member-id>
<no-confirm>
<re0 | re1 | routing-engine (backup | both | local | master | other)>
<satellite [slot-id slot-id |device-alias alias-name]>
```

Syntax (QFX Series)

```
request system storage cleanup
<component (serial number | UUID | all)>
<director-group name>
<dry-run>
<infrastructure name>
```

```

<interconnect-device name>
<name-tag name-tag>
<no-confirm>
<node-group name>
<prune>
<qfabric (component name) | dry-run | name-tag | repository>
<repository (core | log)>
<re0 | re1 | routing-engine (backup | both | local | master | other)>

```

Syntax (SRX Series)

```

request system storage cleanup
<dry-run>
<no-confirm>
<re0 | re1 | routing-engine (backup | both | local | master | other)>

```

Description

Use this command to free storage space on the router or switch by rotating log files and proposing a list of files for deletion. On a QFabric system, you can delete debug files located on individual devices or on the entire QFabric system.

Options

all-members	(EX4200 switches and MX Series routers only) (Optional) Delete files on the Virtual Chassis primary Routing Engine only. To delete files on the other members of the Virtual Chassis configuration, log in to each backup Routing Engine and delete the files using the <code>request system storage cleanup local</code> command.
component (<i>UUID</i> <i>serial number</i> all)	(QFabric systems only) (Optional) Delete files located on individual QFabric system devices or on the entire QFabric system.
director-group <i>name</i>	(QFabric systems only) (Optional) Delete files on the director group.
dry-run	(Optional) List files proposed for deletion (without deleting them).
infrastructure <i>name</i>	(QFabric systems only) (Optional) Delete files on the fabric control Routing Engine and fabric manager Routing Engine.

interconnect-device <i>name</i>	(QFabric systems only) (Optional) Delete files on the Interconnect device.
local	(EX4200 switches and MX Series routers only) (Optional) Delete files on the local Virtual Chassis member.
member <i>member-id</i>	(EX4200 switches and MX Series routers only) (Optional) Delete files on the specified member of the Virtual Chassis configuration. For EX4200 switches, replace <i>member-id</i> with a value from 0 through 9. For an MX Series Virtual Chassis, replace <i>member-id</i> with a value of 0 or 1.
name-tag <i>name-tag</i>	(QFabric systems only) (Optional) Delete debug files that match a specific regular expression.
node-group <i>name</i>	(QFabric systems only) (Optional) Delete files on the Node group.
no-confirm	(Optional) Do not ask for confirmation before doing the cleanup.
prune	(QFabric systems only) (Optional) Delete debug files located in either the core or log debug repositories of a QFabric system device.
qfabric component <i>name</i>	(QFabric systems only) (Optional) Delete debug files located in the debug repositories of a QFabric system device.
(re0 re1 routing- engine (backup both local master other))	<p>(Optional) Request operation on system storage on RE0, RE1, or on specified Routing Engine by these classifications: backup, both, local, primary, or other.</p> <p>When Routing Engine is specified, the below message is shown before listing the files and deleting them.</p>
	<pre>Please check the list of files to be deleted using the dry-run option. i.e. request system storage cleanup dry-run Do you want to proceed ? [yes,no] (no)</pre>
repository (core log)	(QFabric systems only) (Optional) Specify the repository on the QFabric system device for which you want to delete debug files.
satellite [slot-id <i>slot-id</i> device-alias <i>alias-name</i>]	(Junos Fusion only) (Optional) Specify the satellite device in the Junos Fusion by FPC ID or device alias name for which you want to delete debug files.

Additional Information

If logging is configured and being used, the dry-run option rotates the log files. In that case, the output displays the message “Currently rotating log files, please wait.” If no logging is currently under way, the output displays only a list of files to delete.

Required Privilege Level

maintenance

Output Fields

[Table 12 on page 238](#) describes the output fields for the request system storage cleanup command. Output fields are listed in the approximate order in which they appear.

Table 12: request system storage cleanup Output Fields

Field Name	Field Description
List of files to delete:	Shows list of files available for deletion.
Size	Size of the core-dump file.
Date	Last core-dump file modification date and time.
Name	Name of the core-dump file.
Directory to delete:	Shows list of directories available for deletion.
Repository scope:	Repository where core-dump files and log files are stored. The core-dump files are located in the core repository, and the log files are located in the log repository. The default Repository scope is shared since both the core and log repositories are shared by all of the QFabric system devices.
Repository head:	Name of the top-level repository location.
Repository name:	Name of the repository: core or log.

Table 12: request system storage cleanup Output Fields (Continued)

Field Name	Field Description
Creating list of debug artifacts to be removed under:	Shows location of files available for deletion.
List of debug artifacts to be removed under:	Shows list of files available for deletion.

Sample Output

request system storage cleanup dry-run

```

user@host> request system storage cleanup dry-run
Currently rotating log files, please wait.
This operation can take up to a minute.

List of files to delete:

      Size Date      Name
11.4K Mar  8 15:00 /var/log/messages.1.gz
7245B Feb  5 15:00 /var/log/messages.3.gz
11.8K Feb 22 13:00 /var/log/messages.2.gz
3926B Mar 16 13:57 /var/log/messages.0.gz
3962B Feb 22 12:47 /var/log/sampled.1.gz
4146B Mar  8 12:20 /var/log/sampled.0.gz
4708B Dec 21 11:39 /var/log/sampled.2.gz
7068B Jan 16 18:00 /var/log/messages.4.gz
13.7K Dec 27 22:00 /var/log/messages.5.gz
 890B Feb 22 17:22 /var/tmp/sampled.pkts
65.8M Oct 26 09:10 /var/sw/pkg/jinstall-7.4R1.7-export-signed.tgz
63.1M Oct 26 09:13 /var/sw/pkg/jbundle-7.4R1.7.tgz

```

request system storage cleanup

```

user@host> request system storage cleanup
Currently rotating log files, please wait.

```

This operation can take up to a minute.

List of files to delete:

Size	Date	Name
11.4K	Mar 8 15:00	/var/log/messages.1.gz
7245B	Feb 5 15:00	/var/log/messages.3.gz
11.8K	Feb 22 13:00	/var/log/messages.2.gz
3926B	Mar 16 13:57	/var/log/messages.0.gz
11.6K	Mar 8 15:00	/var/log/messages.5.gz
7254B	Feb 5 15:00	/var/log/messages.6.gz
12.9K	Feb 22 13:00	/var/log/messages.8.gz
3726B	Mar 16 13:57	/var/log/messages.7.gz
3962B	Feb 22 12:47	/var/log/sampled.1.gz
4146B	Mar 8 12:20	/var/log/sampled.0.gz
4708B	Dec 21 11:39	/var/log/sampled.2.gz
7068B	Jan 16 18:00	/var/log/messages.4.gz
13.7K	Dec 27 22:00	/var/log/messages.5.gz
890B	Feb 22 17:22	/var/tmp/sampled.pkts
65.8M	Oct 26 09:10	/var/sw/pkg/jinstall-7.4R1.7-export-signed.tgz
63.1M	Oct 26 09:13	/var/sw/pkg/jbundle-7.4R1.7.tgz

Delete these files ? [yes,no] (yes)

request system storage cleanup director-group (QFabric Systems)

```
user@switch> request system storage cleanup director-group
```

List of files to delete:

Size	Date	Name
4.0K	2011-11-07 05:16:29	/tmp/2064.sfcauth
4.0K	2011-11-07 05:07:34	/tmp/30804.sfcauth
4.0K	2011-11-07 04:13:41	/tmp/26792.sfcauth
4.0K	2011-11-07 04:13:39	/tmp/26432.sfcauth
0	2011-11-07 07:45:40	/tmp/cluster_cleanup.log
1.3M	2011-11-07 07:39:11	/tmp/cn_monitor.20111107-052401.log
4.0K	2011-11-07 07:36:29	/tmp/clustat.28019.log
4.0K	2011-11-07 07:36:29	/tmp/clustat_x.28019.log
9.6M	2011-11-07 05:30:24	/tmp/sfc.2.log
4.0K	2011-11-07 05:28:11	/tmp/mgd-init.1320672491.log
248K	2011-11-07 05:19:24	/tmp/cn_monitor.20111107-045111.log

```

4.0K 2011-11-07 05:17:18 /tmp/clustat.3401.log
4.0K 2011-11-07 05:17:18 /tmp/clustat_x.3401.log
8.0K 2011-11-07 04:58:25 /tmp/mgd-init.1320670633.log
0    2011-11-07 04:54:01 /tmp/mysql_db_install_5.1.37.log
4.0K 2011-11-07 04:52:08 /tmp/cn_send.log
0    2011-11-07 04:52:00 /tmp/init_eth0.log
4.0K 2011-11-07 04:49:35 /tmp/install_interfaces.sh.log
4.0K 2011-11-07 04:48:15 /tmp/bootstrap.sh.log
160K 2011-11-07 04:47:43 /tmp/bootstrap_cleanup.log
38M  2011-11-07 04:42:42 /tmp/cn_monitor.20111104-110308.log
4.0K 2011-11-07 04:38:47 /tmp/clustat.30913.log
4.0K 2011-11-07 04:38:47 /tmp/clustat_x.30913.log
4.0K 2011-11-07 04:38:03 /tmp/dcf_upgrade.sh.remove.log
4.0K 2011-11-07 04:38:03 /tmp/peer_update.log
4.0K 2011-11-07 04:38:02 /tmp/dcf_upgrade.log
4.0K 2011-11-07 04:38:02 /tmp/perl_mark_upgrade.log
8.0K 2011-11-07 04:13:42 /tmp/install_dcf_rpm.log
4.0K 2011-11-07 04:13:06 /tmp/00_cleanup.sh.1320667986.log
0    2011-11-07 04:13:06 /tmp/ccif_patch_4410_4450.sh.1320667986.log
4.0K 2011-11-07 04:13:06 /tmp/dcf-tools.sh.1320667986.log
0    2011-11-07 04:13:06 /tmp/initial.sh.1320667986.log
0    2011-11-07 04:13:06 /tmp/inventory.sh.1320667986.log
4.0K 2011-11-07 04:13:06 /tmp/qf-db.sh.1320667986.log
4.0K 2011-11-07 04:13:06 /tmp/sfc.sh.1320667986.log
8.0K 2011-11-07 04:13:05 /tmp/jinstall-qfabric.log
8.0K 2011-11-04 11:10:24 /tmp/mgd-init.1320430192.log
4.0K 2011-11-04 11:07:03 /tmp/mysql_dcf_db_install.log
8.0K 2011-11-04 10:55:07 /tmp/ccif_patch_4410_4450.sh.1320429307.log
8.0K 2011-11-04 10:55:07 /tmp/initial.sh.1320429307.log
4.0K 2011-11-04 10:55:07 /tmp/inventory.sh.1320429307.log
8.0K 2011-11-04 10:55:07 /tmp/sfc.sh.1320429307.log
4.0K 2011-11-04 10:54:09 /tmp/ks-script-Ax0tz5.log
4.0K 2011-11-07 04:13:06 /tmp//sfc.sh.1320667986.log
8.0K 2011-11-04 10:55:07 /tmp//sfc.sh.1320429307.log

```

Directory to delete:

```
45M 2011-11-08 10:57:43 /tmp/sfc-captures
```

List of files to delete:

	Size	Date	Name
4.0K	2011-11-08	05:47:47	/tmp/5713.sfcauth
4.0K	2011-11-08	05:14:32	/tmp/14494.sfcauth

```
4.0K 2011-11-08 05:11:47 /tmp/9978.sfcauth
4.0K 2011-11-08 05:09:37 /tmp/6128.sfcauth
4.0K 2011-11-08 05:04:28 /tmp/29703.sfcauth
4.0K 2011-11-07 11:59:10 /tmp/7811.sfcauth
4.0K 2011-11-07 11:36:08 /tmp/32415.sfcauth
4.0K 2011-11-07 11:30:30 /tmp/22406.sfcauth
4.0K 2011-11-07 11:24:37 /tmp/12131.sfcauth
4.0K 2011-11-07 10:48:42 /tmp/12687.sfcauth
4.0K 2011-11-07 09:27:20 /tmp/31082.sfcauth
4.0K 2011-11-07 07:33:58 /tmp/14633.sfcauth
4.0K 2011-11-07 05:08:25 /tmp/15447.sfcauth
4.0K 2011-11-07 04:12:29 /tmp/26874.sfcauth
4.0K 2011-11-07 04:12:27 /tmp/26713.sfcauth
4.0K 2011-11-07 03:49:17 /tmp/17691.sfcauth
4.0K 2011-11-05 01:32:23 /tmp/5716.sfcauth
4.0K 2011-11-07 08:00:17 /tmp/sfcsnmpd.log
4.0K 2011-11-07 07:57:50 /tmp/cluster_cleanup.log
824K 2011-11-07 07:38:37 /tmp/cn_monitor.20111107-053643.log
4.0K 2011-11-07 07:36:30 /tmp/clustat.18399.log
4.0K 2011-11-07 07:36:30 /tmp/clustat_x.18399.log
4.0K 2011-11-07 07:35:47 /tmp/command_lock.log
4.0K 2011-11-07 05:39:54 /tmp/mgd-init.1320673194.log
92K 2011-11-07 05:19:25 /tmp/cn_monitor.20111107-050412.log
4.0K 2011-11-07 05:17:20 /tmp/clustat.30115.log
4.0K 2011-11-07 05:17:20 /tmp/clustat_x.30115.log
8.0K 2011-11-07 05:08:07 /tmp/mgd-init.1320671241.log
4.0K 2011-11-07 05:04:57 /tmp/cn_send.log
0 2011-11-07 05:04:52 /tmp/init_eth0.log
4.0K 2011-11-07 05:02:38 /tmp/install_interfaces.sh.log
4.0K 2011-11-07 05:01:19 /tmp/bootstrap.sh.log
160K 2011-11-07 05:00:47 /tmp/bootstrap_cleanup.log
28M 2011-11-07 04:42:27 /tmp/cn_monitor.20111104-112954.log
4.0K 2011-11-07 04:38:49 /tmp/clustat.6780.log
4.0K 2011-11-07 04:38:49 /tmp/clustat_x.6780.log
4.0K 2011-11-07 04:38:05 /tmp/issue_event.log
4.0K 2011-11-07 04:38:05 /tmp/peer_upgrade_reboot.log
12K 2011-11-07 04:38:05 /tmp/primary_update.log
4.0K 2011-11-07 04:38:04 /tmp/dcf_upgrade.sh.remove.log
4.0K 2011-11-07 04:38:04 /tmp/peer_rexec_upgrade.log
4.0K 2011-11-07 04:13:42 /tmp/peer_install_dcf_rpm.log
4.0K 2011-11-07 04:11:57 /tmp/dcf-tools.sh.1320667917.log
0 2011-11-07 04:11:57 /tmp/initial.sh.1320667917.log
0 2011-11-07 04:11:57 /tmp/inventory.sh.1320667917.log
```

```

4.0K  2011-11-07 04:11:57 /tmp/qf-db.sh.1320667917.log
4.0K  2011-11-07 04:11:57 /tmp/sfc.sh.1320667917.log
4.0K  2011-11-07 04:11:56 /tmp/00_cleanup.sh.1320667916.log
0     2011-11-07 04:11:56 /tmp/ccif_patch_4410_4450.sh.1320667916.log
8.0K  2011-11-07 04:11:56 /tmp/jinstall-qfabric.log
4.0K  2011-11-07 04:11:33 /tmp/dcf_upgrade.log
8.0K  2011-11-04 11:53:12 /tmp/mgd-init.1320432782.log
8.0K  2011-11-04 11:06:17 /tmp/ccif_patch_4410_4450.sh.1320429977.log
8.0K  2011-11-04 11:06:17 /tmp/initial.sh.1320429977.log
4.0K  2011-11-04 11:06:17 /tmp/inventory.sh.1320429977.log
8.0K  2011-11-04 11:06:17 /tmp/sfc.sh.1320429977.log
4.0K  2011-11-04 11:05:19 /tmp/ks-script-tnWeb.log
4.0K  2011-11-07 04:11:57 /tmp//sfc.sh.1320667917.log
8.0K  2011-11-04 11:06:17 /tmp//sfc.sh.1320429977.log

```

Directory to delete:

```
49M  2011-11-08 10:45:20 /tmp/sfc-captures
```

request system storage cleanup infrastructure device-name (QFabric Systems)

```
user@switch> request system storage cleanup infrastructure FC
```

```
re0:
```

```
-----
```

List of files to delete:

Size	Date	Name
139B	Nov 8 19:03	/var/log/default-log-messages.0.gz
5602B	Nov 8 19:03	/var/log/messages.0.gz
28.4K	Nov 8 10:15	/var/log/messages.1.gz
35.2K	Nov 7 13:45	/var/log/messages.2.gz
207B	Nov 7 16:02	/var/log/wtmp.0.gz
27B	Nov 7 12:14	/var/log/wtmp.1.gz
184.4M	Nov 7 12:16	/var/sw/pkg/jinstall-dc-re-11.3I20111104_1216_dc-builder-domestic-signed.tgz
124.0K	Nov 7 15:59	/var/tmp/gres-tp/env.dat
0B	Nov 7 12:57	/var/tmp/gres-tp/lock
155B	Nov 7 16:02	/var/tmp/krt_gencfg_filter.txt
0B	Nov 7 12:35	/var/tmp/last_ccif_update
1217B	Nov 7 12:15	/var/tmp/loader.conf.preinstall
184.4M	Nov 6 07:11	/var/tmp/mchassis-install.tgz
10.8M	Nov 7 12:16	/var/tmp/preinstall/bootstrap-install-11.3I20111104_1216_dc-builder.tar

```

57.4K Nov 7 12:16 /var/tmp/preinstall/configs-11.3I20111104_1216_dc-builder.tgz
259B Nov 7 12:16 /var/tmp/preinstall/install.conf
734.3K Nov 4 13:46 /var/tmp/preinstall/jboot-dc-re-11.3I20111104_1216_dc-builder.tgz
177.8M Nov 7 12:16 /var/tmp/preinstall/jbundle-dc-re-11.3I20111104_1216_dc-builder-domestic.tgz
124B Nov 7 12:15 /var/tmp/preinstall/metatags
1217B Nov 7 12:16 /var/tmp/preinstall_boot_loader.conf
0B Nov 7 16:02 /var/tmp/rtbdb/if-rtbdb

```

request system storage cleanup interconnect-device device-name (QFabric Systems)

```

user@switch> request system storage cleanup interconnect IC
re1:

```

List of files to delete:

Size	Date	Name
11B	Nov 7 15:55	/var/jail/tmp/alarmd.ts
128B	Nov 8 19:06	/var/log/default-log-messages.0.gz
9965B	Nov 8 19:06	/var/log/messages.0.gz
15.8K	Nov 8 12:30	/var/log/messages.1.gz
15.8K	Nov 8 11:00	/var/log/messages.2.gz
15.7K	Nov 8 07:30	/var/log/messages.3.gz
15.8K	Nov 8 04:00	/var/log/messages.4.gz
15.7K	Nov 8 00:30	/var/log/messages.5.gz
18.7K	Nov 7 21:00	/var/log/messages.6.gz
17.6K	Nov 7 19:00	/var/log/messages.7.gz
58.3K	Nov 7 16:00	/var/log/messages.8.gz
20.3K	Nov 7 15:15	/var/log/messages.9.gz
90B	Nov 7 15:41	/var/log/wtmp.0.gz
57B	Nov 7 12:41	/var/log/wtmp.1.gz
124.0K	Nov 7 15:42	/var/tmp/gres-tp/env.dat
0B	Nov 7 12:40	/var/tmp/gres-tp/lock
0B	Nov 7 12:41	/var/tmp/if-rtbdb/env.lck
12.0K	Nov 7 15:41	/var/tmp/if-rtbdb/env.mem
132.0K	Nov 7 15:55	/var/tmp/if-rtbdb/shm_usr1.mem
2688.0K	Nov 7 15:41	/var/tmp/if-rtbdb/shm_usr2.mem
2048.0K	Nov 7 15:41	/var/tmp/if-rtbdb/trace.mem
730B	Nov 7 19:57	/var/tmp/juniper.conf+.gz
155B	Nov 7 15:53	/var/tmp/krt_gencfg_filter.txt
0B	Nov 7 15:41	/var/tmp/rtbdb/if-rtbdb

```
re0:
```

```
-----
```

List of files to delete:

	Size	Date	Name
	11B	Nov 7 15:55	/var/jail/tmp/alarmd.ts
	121B	Nov 8 19:06	/var/log/default-log-messages.0.gz
	16.7K	Nov 8 19:06	/var/log/messages.0.gz
	22.2K	Nov 8 17:45	/var/log/messages.1.gz
	K	Nov 8 17:00	/var/log/messages.2.gz
	21.6K	Nov 8 16:00	/var/log/messages.3.gz
	17.9K	Nov 8 14:30	/var/log/messages.4.gz
	19.4K	Nov 8 13:30	/var/log/messages.5.gz
	18.2K	Nov 8 12:30	/var/log/messages.6.gz
	20.4K	Nov 8 11:30	/var/log/messages.7.gz
	21.4K	Nov 8 10:15	/var/log/messages.8.gz
	21.0K	Nov 8 09:00	/var/log/messages.9.gz
	19.9K	Nov 8 08:13	/var/log/snmp-traps.0.gz
	203B	Nov 8 15:36	/var/log/wtmp.0.gz
	57B	Nov 7 12:41	/var/log/wtmp.1.gz
	124.0K	Nov 7 15:42	/var/tmp/gres-tp/env.dat
	0B	Nov 7 12:40	/var/tmp/gres-tp/lock
	0B	Nov 7 12:41	/var/tmp/if-rtsdb/env.lck
	12.0K	Nov 7 15:41	/var/tmp/if-rtsdb/env.mem
	132.0K	Nov 7 15:55	/var/tmp/if-rtsdb/shm_usr1.mem
	2688.0K	Nov 7 15:41	/var/tmp/if-rtsdb/shm_usr2.mem
	2048.0K	Nov 7 15:41	/var/tmp/if-rtsdb/trace.mem
	727B	Nov 7 15:54	/var/tmp/juniper.conf+.gz
	155B	Nov 7 15:55	/var/tmp/krt_gencfg_filter.txt
	0B	Nov 7 15:41	/var/tmp/rtsdb/if-rtsdb

request system storage cleanup node-group group-name (QFabric Systems)

```
user@switch> request system storage cleanup node-group NW-NG
BBAK0372:
```

```
-----
```

List of files to delete:

Size	Date	Name
126B	Nov 8 19:07	/var/log/default-log-messages.0.gz
179B	Nov 7 13:32	/var/log/install.0.gz
22.9K	Nov 8 19:07	/var/log/messages.0.gz
26.5K	Nov 8 17:30	/var/log/messages.1.gz
20.5K	Nov 8 13:15	/var/log/messages.2.gz
33.2K	Nov 7 17:45	/var/log/messages.3.gz
35.5K	Nov 7 15:45	/var/log/messages.4.gz
339B	Nov 8 17:10	/var/log/wtmp.0.gz
58B	Nov 7 12:40	/var/log/wtmp.1.gz
124.0K	Nov 8 17:08	/var/tmp/gres-tp/env.dat
0B	Nov 7 12:39	/var/tmp/gres-tp/lock
0B	Nov 7 12:59	/var/tmp/if-rtbdb/env.lck
12.0K	Nov 8 17:09	/var/tmp/if-rtbdb/env.mem
2688.0K	Nov 8 17:09	/var/tmp/if-rtbdb/shm_usr1.mem
132.0K	Nov 8 17:09	/var/tmp/if-rtbdb/shm_usr2.mem
2048.0K	Nov 8 17:09	/var/tmp/if-rtbdb/trace.mem
1082B	Nov 8 17:09	/var/tmp/juniper.conf+.gz
155B	Nov 7 17:39	/var/tmp/krt_gencfg_filter.txt
0B	Nov 8 17:09	/var/tmp/rtbdb/if-rtbdb

EE3093:

List of files to delete:

Size	Date	Name
11B	Nov 8 17:33	/var/jail/tmp/alarmd.ts
119B	Nov 8 19:08	/var/log/default-log-messages.0.gz
180B	Nov 7 17:41	/var/log/install.0.gz
178B	Nov 7 13:32	/var/log/install.1.gz
2739B	Nov 8 19:08	/var/log/messages.0.gz
29.8K	Nov 8 18:45	/var/log/messages.1.gz
31.8K	Nov 8 17:15	/var/log/messages.2.gz
20.6K	Nov 8 16:00	/var/log/messages.3.gz
15.4K	Nov 8 10:15	/var/log/messages.4.gz
15.4K	Nov 8 02:15	/var/log/messages.5.gz
25.5K	Nov 7 20:45	/var/log/messages.6.gz
48.0K	Nov 7 17:45	/var/log/messages.7.gz
32.8K	Nov 7 13:45	/var/log/messages.8.gz
684B	Nov 8 17:02	/var/log/wtmp.0.gz
58B	Nov 7 12:40	/var/log/wtmp.1.gz
124.0K	Nov 7 17:34	/var/tmp/gres-tp/env.dat

```

0B Nov 7 12:40 /var/tmp/gres-tp/lock
0B Nov 7 12:59 /var/tmp/if-rtbdb/env.lck
12.0K Nov 7 17:39 /var/tmp/if-rtbdb/env.mem
2688.0K Nov 7 17:39 /var/tmp/if-rtbdb/shm_usr1.mem
132.0K Nov 7 17:40 /var/tmp/if-rtbdb/shm_usr2.mem
2048.0K Nov 7 17:39 /var/tmp/if-rtbdb/trace.mem
155B Nov 7 17:40 /var/tmp/krt_gencfg_filter.txt
0B Nov 7 17:39 /var/tmp/rtbdb/if-rtbdb

```

request system storage cleanup qfabric component device-name (QFabric Systems)

```

user@switch> request system storage cleanup qfabric component Test
Repository type: regular
Repository head: /pbstorage
Creating list of debug artifacts to be removed under: /pbstorage/rdumps/Test
Removing debug artifacts ... (press control C to abort)
Removing /pbstorage/rdumps/Test/cosd.core.0.0.05162011123308.gz ... done
Removing /pbstorage/rdumps/Test/cosd.core.1.0.05162011123614.gz ... done
Removing /pbstorage/rdumps/Test/cosd.core.2.0.05162011123920.gz ... done
Removing /pbstorage/rdumps/Test/livecore.05132011163930.gz ... done
Removing /pbstorage/rdumps/Test/tnetd.core.0.1057.05162011124500.gz ... done
Removing /pbstorage/rdumps/Test/vmcore.05132011120528.gz ... done
Removing /pbstorage/rdumps/Test/vmcore.kz ... done
Creating list of debug artifacts to be removed under: /pbstorage/rlogs/Test
Removing debug artifacts ... (press control C to abort)
Removing /pbstorage/rlogs/Test/kdumpinfo.05132011120528 ... done
Removing /pbstorage/rlogs/Test/kernel.tarball.0.1039.05122011234415.tgz ... done
Removing /pbstorage/rlogs/Test/kernel.tarball.1.1039.05132011175544.tgz ... done
Removing /pbstorage/rlogs/Test/tnetd.tarball.0.1057.05162011175453.tgz ... done

```

request system storage cleanup qfabric component device-name repository core (QFabric Systems)

```

user@switch> request system storage cleanup qfabric component Test repository core
Repository scope: shared
Repository head: /pbdata/export
Repository name: core
Creating list of debug artifacts to be removed under: /pbdata/export/rdumps/Test
NOTE: core repository under /pbdata/export/rdumps/Test empty

```

request system storage cleanup qfabric component all (QFabric Systems)

```
user@switch> request system storage cleanup qfabric component all
Repository scope: shared
Repository head: /pbdata/export
Creating list of debug artifacts to be removed under: /pbdata/export/rdumps
NOTE: core repository under /pbdata/export/rdumps/all empty
Creating list of debug artifacts to be removed under: /pbdata/export/rlogs
List of debug artifacts to clean up ... (press control C to abort)
/pbdata/export/rlogs/73747cd8-0710-11e1-b6a4-00e081c5297e/install-11072011125819.log
/pbdata/export/rlogs/77116f18-0710-11e1-a2a0-00e081c5297e/install-11072011125819.log
/pbdata/export/rlogs/BBAK0372/install-11072011121538.log
/pbdata/export/rlogs/BBAK0394/install-11072011121532.log
/pbdata/export/rlogs/EE3093/install-11072011121536.log
/pbdata/export/rlogs/WS001/YN5999/install-11072011121644.log
/pbdata/export/rlogs/WS001/YW3803/install-11072011122429.log
/pbdata/export/rlogs/cd78871a-0710-11e1-878e-00e081c5297e/install-11072011125932.log
/pbdata/export/rlogs/d0afda1e-0710-11e1-a1d0-00e081c5297e/install-11072011125930.log
/pbdata/export/rlogs/d0afda1e-0710-11e1-a1d0-00e081c5297e/install-11072011133211.log
/pbdata/export/rlogs/d0afda1e-0710-11e1-a1d0-00e081c5297e/install-11072011155302.log
/pbdata/export/rlogs/d31ab7a6-0710-11e1-ad1b-00e081c5297e/install-11072011125931.log
/pbdata/export/rlogs/d4d0f254-0710-11e1-90c3-00e081c5297e/install-11072011125932.log
```

Release Information

Command introduced in Junos OS Release 7.4.

dry-run option introduced in Junos OS Release 7.6.

satellite option introduced in Junos OS Release 14.2R3.

no-confirm and (re0 |re1 | routing-engine (backup | both | local | master | other)) options introduced in Junos OS 17.3R1.

show chassis alarms

IN THIS SECTION

- [Syntax](#) | 249
- [Syntax \(MX Series Routers\)](#) | 249
- [Syntax \(SRX1500, SRX4100, and SRX4200\)](#) | 250
- [Syntax \(SRX4600\)](#) | 250
- [Syntax \(SRX5400\)](#) | 250
- [Syntax \(TX Matrix Routers\)](#) | 250
- [Syntax \(TX Matrix Plus Routers\)](#) | 251
- [Syntax \(MX104, MX2010, MX2020, and MX2008 Universal Routing Platforms\)](#) | 251
- [Syntax \(MX204, MX10003, MX10004, MX10008, OCX Series, PTX Series, ACX Series, EX9251, and EX9253\)](#) | 251
- [Syntax \(QFX Series\)](#) | 251
- [Description](#) | 251
- [Options](#) | 251
- [Additional Information](#) | 252
- [Required Privilege Level](#) | 258
- [Output Fields](#) | 258
- [Sample Output](#) | 259
- [show chassis alarms \(ACX7024\)](#) | 277
- [Release Information](#) | 278

Syntax

```
show chassis alarms
```

Syntax (MX Series Routers)

```
show chassis alarms  
<all-members>
```

```
<local>
<member member-id>
```

Syntax (SRX1500, SRX4100, and SRX4200)

```
show chassis alarms
1 alarms currently active
Alarm time          Class  Description
2020-02-28 10:07:16 CST Major FPC0: PEM 0 Not Present
```

Syntax (SRX4600)

```
show chassis alarms
node0:
-----
2 alarms currently active
Alarm time Class Description
2020-10-08 19:42:06 UTC Major FPC 0 BITS CPLD Version Mismatch
2020-10-08 19:42:06 UTC Minor PEM 1 Not Present
```

Syntax (SRX5400)

```
show chassis alarms
1 alarms currently active
Alarm time          Class  Description
2021-04-16 17:21:02 PDT Major Too Few AC PEMs
```

Syntax (TX Matrix Routers)

```
show chassis alarms
<lcc number | scc>
```

Syntax (TX Matrix Plus Routers)

```
show chassis alarms
<lcc number | sfc number>
```

Syntax (MX104, MX2010, MX2020, and MX2008 Universal Routing Platforms)

```
show chassis alarms
<satellite [slot-id slot-id]>
```

Syntax (MX204, MX10003, MX10004, MX10008, OCX Series, PTX Series, ACX Series, EX9251, and EX9253)

```
show chassis alarms
```

Syntax (QFX Series)

```
show chassis alarms
<interconnect-device name>
<node-device name>
```

Description

Display information about the conditions that have been configured to trigger alarms. In Junos, the chassis alarms are different from the system alarms (viewed by using the `show system alarms` command). The system alarms indicate a missing rescue configuration or software license, where valid. For more information, see [Alarm Overview](#).

Options

- | | |
|--------------------|---|
| none | Display information about the conditions that have been configured to trigger alarms. |
| all-members | (MX Series routers only) (Optional) Display information about alarm conditions for all the member routers of the Virtual Chassis configuration. |

interconnect-device <i>name</i>	(QFabric systems only) (Optional) Display information about alarm conditions for the Interconnect device.
lcc <i>number</i>	(TX Matrix router and TX Matrix Plus router only) (Optional) Line-card chassis number. Replace <i>number</i> with the following values depending on the LCC configuration: <ul style="list-style-type: none"> • 0 through 3, when T640 routers are connected to a TX Matrix router in a routing matrix. • 0 through 3, when T1600 routers are connected to a TX Matrix Plus router in a routing matrix. • 0 through 7, when T1600 routers are connected to a TX Matrix Plus router with 3D SIBs in a routing matrix. • 0, 2, 4, or 6, when T4000 routers are connected to a TX Matrix Plus router with 3D SIBs in a routing matrix.
local	(MX Series routers only) (Optional) Display information about alarm conditions for the local Virtual Chassis member.
member <i>member-id</i>	(MX Series routers only) (Optional) Display information about alarm conditions for the specified member of the Virtual Chassis configuration. Replace <i>member-id</i> variable with a value of 0 or 1.
node-device <i>name</i>	(QFabric systems only) (Optional) Display information about alarm conditions for the Node device.
satellite [slot-id <i>slot-id</i>]	(Junos Fusion only)(Optional) Display information about alarm conditions for the specified satellite device in a Junos Fusion, or for all satellite devices in the Junos Fusion if no satellite devices are specified.
scc	(TX Matrix router only) (Optional) Show information about the TX Matrix router (switch-card chassis).
sfc <i>number</i>	(TX Matrix Plus router only) (Optional) Show information about the respective TX Matrix Plus router, which is the switch-fabric chassis. Replace <i>number</i> variable with 0.

Additional Information

Chassis alarms are preset. You cannot modify them.

You cannot clear the alarms for chassis components. Instead, you must remedy the cause of the alarm. When a chassis alarm LED is lit, it indicates that you are running the router or switch in a manner that we do not recommend.

On routers, you can manually silence external devices connected to the alarm relay contacts by pressing the alarm cutoff button, located on the craft interface. Silencing the device does not remove the alarm messages from the display (if present on the router) or extinguish the alarm LEDs. In addition, new alarms that occur after you silence an external device reactivate the external device.

NOTE: MX10003 routers do not support craft interface.

In Junos OS release 11.1 and later, alarms for fans also show the slot number of the fans in the CLI output.

In Junos OS Release 11.2 and later, the command output on EX8200 switches shows the detailed location (Plane/FPC/PFE) for link errors in the chassis.

In Junos OS Release 10.2 and later, an alarm is shown on T Series routers for a standby SONET Clock Generator (SCG) that is offline or absent.

You may often see the following error messages, in which only the error code is shown and no other information is provided:

```
Apr 12 08:04:10 send: red alarm set, device FPC 6, reason FPC 6 Major Errors - Error code: 257
Apr 12 08:04:19 send: red alarm set, device FPC 1, reason FPC 1 Major Errors - Error code: 559
```

To understand what CM_ALARM error codes mean, you need to first identify the structure of the CM Alarm codes. A CM_ALARM code has the following structure:

Bits:	Error type:
1-31	Major (1)
0	Minor (0)

According to the table above, the LSB (bit 0) identifies the **Error Type** (major alarm, if the bit is set and minor alarm if the bit is unset). The rest of the bits (1 - 31) identify the actual error code.

Take an example of the following error code, which was logged on a T1600:

```
Apr 12 08:04:10 send: red alarm set, device FPC 1, reason FPC 1 Major Errors - Error code: 559
```

First, you have to convert 559 to binary; that is **1000101111**. The LSB in this case is **1**, which means that this is a major alarm. After removing the LSB, you are left with **100010111**, which is equal to 279 in decimal. This is the actual error code, its meaning can be found from the following list:

Chip Type: L Chip	Code
CMALARM_LCHIP_LOUT_DESRD_PARITY_ERR	1
CMALARM_LCHIP_LOUT_DESRD_UNINIT_ERR	2
CMALARM_LCHIP_LOUT_DESRD_ILLEGALLINK_ERR	3
CMALARM_LCHIP_LOUT_DESRD_ILLEGALSIZERR	4
CMALARM_LCHIP_LOUT_HDRF_TOERR_ERR	5
CMALARM_LCHIP_LOUT_HDRF_PARITY_ERR	6
CMALARM_LCHIP_LOUT_HDRF_UCERR_ERR	7
CMALARM_LCHIP_LOUT_NLIF_CRCDROP_ERR	8
CMALARM_LCHIP_LOUT_NLIF_CRCERR_ERR	9
CMALARM_LCHIP_UCODE_TIMEOUT_ERR	10
CMALARM_LCHIP_LIN_SRCTL_ACCT_DROP_ERR	11
CMALARM_LCHIP_LIN_SRCTL_ACCT_ADDR_SIZE_ERR	12
CMALARM_LCHIP_SRAM_PARITY_ERR	13

CMALARM_LCHIP_UCODE_OVFLW_ERR	14
CMALARM_LCHIP_LOUT_HDRF_MTU_ERR	15
Chip Type: M Chip	Code
CMALARM_MCHIP_ECC_UNCORRECT_ERR	128
Chip Type: N Chip	Code
CMALARM_NCHIP_RDDMA_JBUS_TIMEOUT_ERR	256
CMALARM_NCHIP_RDDMA_FIFO_OVFLW_ERR	257
CMALARM_NCHIP_RDDMA_FIFO_UNFLW_ERR	258
CMALARM_NCHIP_RDDMA_SIZE_ERR	259
CMALARM_NCHIP_RDDMA_JBUS_CRC_ERR	260
CMALARM_NCHIP_WRDMA_PKTR_ERR	261
CMALARM_NCHIP_WRDMA_PKT_CRC_ERR	262
CMALARM_NCHIP_WRDMA_JBUS_TIMEOUT_ERR	263
CMALARM_NCHIP_WRDMA_FIFO_OVFLW_ERR	264
CMALARM_NCHIP_WRDMA_FIFO_UNFLW_ERR	265
CMALARM_NCHIP_WRDMA_PKT_LEN_ERR	266

CMALARM_NCHIP_WRDMA_JBUS_CRC_ERR	267
CMALARM_NCHIP_PKTR_DMA_AGE_ERR	268
CMALARM_NCHIP_PKTR_ICELLSIG_ERR	269
CMALARM_NCHIP_PKTR_FTTL_ERR	270
CMALARM_NCHIP_RODR_OFFSET_OVFLW_ERR	271
CMALARM_NCHIP_PKTR_TMO_CELL_ERR	272
CMALARM_NCHIP_PKTR_TMO_OUTRANGE_ERR	273
CMALARM_NCHIP_PKTR_MD_REQUEST_Q_OVFLW_ERR	274
CMALARM_NCHIP_PKTR_DMA_BUFFER_OVFLW_ERR	275
CMALARM_NCHIP_PKTR_GRT_OVFLW_ERR	276
CMALARM_NCHIP_FRQ_ERR	277
CMALARM_NCHIP_RODR_IN_Q_OVFLW_ERR	278
CMALARM_NCHIP_DBUF_CRC_ERR	279

Chip Type: R Chip	Code
CMALARM_RCHIP_SRAM_PARITY_ERR	512
Chip Type: R Chip	Code

CMALARM_ICHIP_WO_DESRD_ID_ERR	601
CMALARM_ICHIP_WO_DESRD_DATA_ERR	602
CMALARM_ICHIP_WO_DESRD_OFLOW_ERR	603
CMALARM_ICHIP_WO_HDRF_UCERR_ERR	604
CMALARM_ICHIP_WO_HDRF_MTUERR_ERR	605
CMALARM_ICHIP_WO_HDRF_PARITY_ERR	606
CMALARM_ICHIP_WO_HDRF_TOERR_ERR	607
CMALARM_ICHIP_WO_IP_CRC_ERR	608
CMALARM_ICHIP_WO_IP_INTER_ERR	609
CMALARM_ICHIP_WI_WAN_TIMEOUT_ERR	625
CMALARM_ICHIP_WI_FAB_TIMEOUT_ERR	626
CMALARM_ICHIP_RLDRAM_BIST_ERR	630
CMALARM_ICHIP_SDRAM_BIST_ERR	631
CMALARM_ICHIP_RLDRAM_PARITY_ERR	632
CMALARM_ICHIP_SDRAM_UNCORRECT_ERR	633
CMALARM_ICHIP_SDRAM_CORRECT_ERR	634
CMALARM_ICHIP_FUSE_DONE_ERR	635

According to the table above, the **279** error code corresponds to **CMALARM_NCHIP_DBUF_CRC_ERR**; this means that new CRC errors were seen on the NCHIP of this particular FPC, which is FPC as per the logs.

If you do not want to convert decimal to binary and vice versa, you may use the following shortcut:

For major alarms, the **Actual Error Code = (Error Code - 1)/2**, where **Error Code** is the code that you get in the log message. For example, if you get the following log:

```
Apr 12 08:04:10 send: red alarm set, device FPC 6, reason FPC 6 Major Errors - Error code:
257
```

Actual Error Code = $(257-1)/2 = 128$. Similarly, for minor alarms, Actual Error Code = $(\text{Error Code})/2$

NOTE: Starting in Junos OS Release 18.2R1, on MX Series routers, the `show chassis alarms` output does not display error codes for PFE-related errors. You can use the following commands to view more details of the errors that caused the alarms:

- `show chassis errors active`
- `show chassis errors active detail`

Required Privilege Level

view

Output Fields

[Table 13 on page 258](#) lists the output fields for the `show chassis alarms` command. Output fields are listed in the approximate order in which they appear.

Table 13: show chassis alarms Output Fields

Field Name	Field Description
Alarm time	Date and time the alarm was first recorded.
Class	Severity class for this alarm: Minor or Major.

Table 13: show chassis alarms Output Fields (Continued)

Field Name	Field Description
Description	Information about the alarm.

Sample Output

show chassis alarms (Alarms Active)

```

user@host> show chassis alarms
3 alarms are currently active
Alarm time          Class Description
2000-02-07 10:12:22 UTC Major fxp0: ethernet link down
2000-02-07 10:11:54 UTC Minor YELLOW ALARM - PEM 1 Removed
2000-02-07 10:11:03 UTC Minor YELLOW ALARM - Lower Fan Tray Removed

```

show chassis alarms (No Alarms Active)

```

user@host> show chassis alarms
No alarms are currently active

```

show chassis alarms (Fan Tray)

```

user@host> show chassis alarms
4 alarms currently active
Alarm time          Class Description
2010-11-11 20:27:38 UTC Major Side Fan Tray 7 Failure
2010-11-11 20:27:13 UTC Minor Side Fan Tray 7 Overspeed
2010-11-11 20:27:13 UTC Major Side Fan Tray 5 Failure
2010-11-11 20:27:13 UTC Major Side Fan Tray 0 Failure

```

show chassis alarms (MX150)

```

user@host > show chassis alarms
1 alarms currently active
Alarm time          Class  Description
2016-06-04 01:49:43 PDT  Major  Fan Tray 1 Fan 0 failed

```

show chassis alarms (MX104 Router)

```

user@host >show chassis alarms
1 alarms currently active
Alarm time          Class  Description
2013-06-05 14:43:31 IST  Minor  Backup RE Active

```

show chassis alarms (MX2010 Router)

```

user@host> show chassis alarms
7 alarms currently active
Alarm time          Class  Description
2012-08-07 00:46:06 PDT  Major  Fan Tray 2 Failure
2012-08-06 18:24:36 PDT  Minor  Redundant feed missing for PSM 6
2012-08-06 07:41:04 PDT  Minor  Redundant feed missing for PSM 8
2012-08-04 02:42:06 PDT  Minor  Redundant feed missing for PSM 5
2012-08-03 21:14:24 PDT  Minor  Loss of communication with Backup RE
2012-08-03 12:26:03 PDT  Minor  Redundant feed missing for PSM 4
2012-08-03 10:40:18 PDT  Minor  Redundant feed missing for PSM 7

```

show chassis alarms (MX2020 Router)

```

user@host> show chassis alarms
1 alarms currently active
Alarm time Class Description
2012-10-03 12:14:59 PDT Minor Plane 0 not online

```

show chassis alarms (MX10003 Router)

```

user@host> show chassis alarms

9 alarms currently active
Alarm time          Class Description
2017-07-13 21:50:31 PDT Major FPC 1 Temperature Hot
2017-07-13 21:50:04 PDT Minor FPC 1 PIC 1 Invalid port profile configuration
2017-07-13 21:49:13 PDT Minor FPC 1 PIC 0 Invalid port profile configuration
2017-07-13 21:48:54 PDT Major FPC 0 Temperature Hot
2017-07-13 21:43:54 PDT Minor CB 1 Voltage Sensor ADS7830_0x4B Sensor Failed
2017-07-13 21:43:54 PDT Minor CB 0 Voltage Sensor ADS7830_0x4B Sensor Failed
2017-07-13 21:43:31 PDT Minor Loss of communication with Backup RE

```

Starting in Junos OS Release 19.2R1, the MX10003 routers do not raise an alarm if a Power Entry Module (PEM) slot is empty. However, when the number of operational PEMs goes below 2, the router raises a major alarm. This alarm is cleared when the required number of PEMs are made available.

show chassis alarms (MX10004 Router)

```

user@host> show chassis alarms

2 alarms currently active
Alarm time          Class Description
2022-07-05 20:34:40 PDT Major Fan Tray 0 EEPROM Read Error
2021-17-05 11:06:47 PST Minor Check plane 0 Fabric Chip

```

```

user@host> show chassis alarms | match PEM
2021-11-12 13:19:35 UTC Major PEM 2 Not Supported

```

```

user@host> show system alarms | match Fan
2021-09-27 19:13:15 PDT Major Fan Tray 0 Model Not Supported

```

-->

show chassis alarms (MX204 Router)

```

user@host> show chassis alarms

1 alarms currently active
Alarm time           Class Description
2017-11-05 22:13:03 PST Major PEM 0 Not Present

```

show chassis alarms (MX2008 Router)

```

user@host>show chassis alarms
No alarms currently active

```

show chassis alarms (MX960, MX480, and MX240 Routers showing Major CB Failure)

A major CB 0 failure alarm occurs in the event of a bad CB (unknown or mismatched CBs do not trigger this alarm in Junos Release OS 12.3R9 and later). Following GRES or recovery, if the hardware issue persists, the traffic moves to the good CB and continues. If the alarm was triggered by something transient like a power zone budget on GRES, bringing the CB back online can clear the alarm. Otherwise, replace the bad CB. Note that fabric link speed is not impacted by an offline SCB. The alarm might be raised on CB0, CB1, and CB2.

```

user@host> show chassis alarms
6 alarms currently active
Alarm time           Class Description
2014-10-31 16:49:41 EDT Major PEM 3 Not OK
2014-10-31 16:49:41 EDT Major PEM 2 Not OK
2014-10-31 16:49:31 EDT Major CB 0 Failure
2014-10-31 16:49:31 EDT Minor CB 0 Fabric Chip 0 Not Online
2014-10-31 16:49:31 EDT Minor CB 0 Fabric Chip 1 Not Online
2014-10-31 16:49:31 EDT Minor Backup RE Active

```

show chassis alarms (PTX10008 Router)

```

user@host>show chassis alarms
12 alarms currently active
Alarm time           Class Description

```

```

2017-05-09 01:38:55 PDT Minor Loss of communication with Backup RE
2017-05-05 06:49:57 PDT Major FPC 5 LCPU Temp Sensor Access Failed
2017-05-05 06:49:57 PDT Major FPC 5 PE2 Temp Sensor Hot
2017-05-05 06:49:57 PDT Major FPC 5 PE1 Temp Sensor Hot
2017-05-05 06:49:57 PDT Major FPC 5 PE0 Temp Sensor Hot
2017-05-05 06:49:57 PDT Major FPC 5 Exhaust-C Temp Sensor Hot
2017-05-05 06:49:57 PDT Major FPC 5 Exhaust-B Temp Sensor Hot
2017-05-05 06:49:57 PDT Major FPC 5 Exhaust-A Temp Sensor Hot
2017-05-05 06:49:57 PDT Major FPC 5 Intake-B Temp Sensor Access Failed
2017-05-05 06:49:57 PDT Major FPC 5 Intake-A Temp Sensor Access Failed
2017-05-05 06:49:57 PDT Major Fan Tray 0 Fan 5 running at lower speed
2017-05-05 06:49:57 PDT Major Fan Tray 0 Fan 4 running at lower speed

```

show chassis alarms (T4000 Router)

```

user@host> show chassis alarms
9 alarms currently active
Alarm time          Class Description
2007-06-02 01:41:10 UTC Minor RE 0 Not Supported
2007-06-02 01:41:10 UTC Minor CB 0 Not Supported
2007-06-02 01:41:10 UTC Minor Mixed Master and Backup RE types
2007-05-30 19:37:33 UTC Major SPMB 1 not online
2007-05-30 19:37:29 UTC Minor Front Bottom Fan Tray Absent
2007-05-30 19:37:13 UTC Major PEM 1 Input Failure
2007-05-30 19:37:13 UTC Major PEM 0 Not OK
2007-05-30 19:37:03 UTC Major PEM 0 Improper for Platform
2007-05-30 19:37:03 UTC Minor Backup RE Active

```

show chassis alarms (Unreachable Destinations Present on a T Series Router)

```

user@host> show chassis alarms
10 alarms currently active
Alarm time          Class Description
2011-08-30 18:43:53 PDT Major FPC 7 has unreachable destinations
2011-08-30 18:43:53 PDT Major FPC 5 has unreachable destinations
2011-08-30 18:43:52 PDT Major FPC 3 has unreachable destinations
2011-08-30 18:43:52 PDT Major FPC 2 has unreachable destinations
2011-08-30 18:43:52 PDT Minor SIB 0 Not Online
2011-08-30 18:43:33 PDT Minor SIB 4 Not Online
2011-08-30 18:43:28 PDT Minor SIB 3 Not Online

```

```

2011-08-30 18:43:05 PDT Minor SIB 2 Not Online
2011-08-30 18:43:28 PDT Minor SIB 1 Not Online
2011-08-30 18:43:05 PDT Major PEM 1 Not Ok

```

show chassis alarms (FPC Offline Due to Unreachable Destinations on a T Series Router)

```

user@host> show chassis alarms
10 alarms currently active
Alarm time          Class Description
2011-08-30 18:43:53 PDT Major FPC 7 offline due to unreachable destinations
2011-08-30 18:43:53 PDT Major FPC 5 offline due to unreachable destinations
2011-08-30 18:43:52 PDT Major FPC 3 offline due to unreachable destinations
2011-08-30 18:43:52 PDT Major FPC 2 offline due to unreachable destinations
2011-08-30 18:43:52 PDT Minor SIB 0 Not Online
2011-08-30 18:43:33 PDT Minor SIB 4 Not Online
2011-08-30 18:43:28 PDT Minor SIB 3 Not Online
2011-08-30 18:43:05 PDT Minor SIB 2 Not Online
2011-08-30 18:43:28 PDT Minor SIB 1 Not Online
2011-08-30 18:43:05 PDT Major PEM 1 Not Ok

```

show chassis alarms (SCG Absent on a T Series Router)

```

user@host> show chassis alarms
4 alarms currently active
Alarm time          Class Description
2011-01-23 21:42:46 PST Major SCG 0 NO EXT CLK MEAS-BKUP SCG ABS

```

show chassis alarms (Alarms Active on a TX Matrix Router)

```

user@host> show chassis alarms
scc-re0:
-----
8 alarms currently active
Alarm time          Class Description
2004-08-05 18:43:53 PDT Minor LCC 0 Minor Errors
2004-08-05 18:43:53 PDT Minor SIB 3 Not Online
2004-08-05 18:43:52 PDT Major SIB 2 Absent
2004-08-05 18:43:52 PDT Major SIB 1 Absent

```

```

2004-08-05 18:43:52 PDT Major SIB 0 Absent
2004-08-05 18:43:33 PDT Major LCC 2 Major Errors
2004-08-05 18:43:28 PDT Major LCC 0 Major Errors
2004-08-05 18:43:05 PDT Minor LCC 2 Minor Errors
lcc0-re0:

```

```
-----
```

5 alarms currently active

Alarm time	Class	Description
2004-08-05 18:43:53 PDT	Minor	SIB 3 Not Online
2004-08-05 18:43:49 PDT	Major	SIB 2 Absent
2004-08-05 18:43:49 PDT	Major	SIB 1 Absent
2004-08-05 18:43:49 PDT	Major	SIB 0 Absent
2004-08-05 18:43:28 PDT	Major	PEM 0 Not OK

lcc2-re0:

```
-----
```

5 alarms currently active

Alarm time	Class	Description
2004-08-05 18:43:35 PDT	Minor	SIB 3 Not Online
2004-08-05 18:43:33 PDT	Major	SIB 2 Absent
2004-08-05 18:43:33 PDT	Major	SIB 1 Absent
2004-08-05 18:43:33 PDT	Major	SIB 0 Absent
2004-08-05 18:43:05 PDT	Minor	PEM 1 Absent

show chassis alarms (TX Matrix Plus router with 3D SIBs)

```

user@host> show chassis alarms
sfc0-re0:

```

```
-----
```

Alarm time	Class	Description
2014-04-08 14:35:13 IST	Minor	FPM 0 SFC Config Size Changed
2014-04-08 14:32:58 IST	Major	Fan Tray Failure
2014-04-08 14:31:53 IST	Major	SIB F13 6 Fault
2014-04-08 14:31:43 IST	Major	SIB F13 11 Fault
2014-04-08 14:31:08 IST	Minor	Check SIB F13 12 CXP 14 Fbr Cbl
2014-04-08 14:31:08 IST	Minor	Check SIB F13 12 CXP 8 Fbr Cbl
2014-04-08 14:31:08 IST	Minor	Check SIB F13 12 CXP 3 Fbr Cbl
2014-04-08 14:31:08 IST	Major	SIB F13 12 CXP 15 fault
2014-04-08 14:31:08 IST	Minor	SIB F13 12 CXP 14 LOL
2014-04-08 14:31:08 IST	Minor	Check SIB F13 12 CXP 14
2014-04-08 14:31:08 IST	Major	SIB F13 12 CXP 10 fault

2014-04-08 14:31:08 IST Minor SIB F13 12 CXP 8 LOL
 2014-04-08 14:31:08 IST Minor Check SIB F13 12 CXP 8
 2014-04-08 14:31:08 IST Major SIB F13 12 CXP 7 fault
 2014-04-08 14:31:08 IST Major SIB F13 12 CXP 4 fault
 2014-04-08 14:31:08 IST Minor SIB F13 12 CXP 3 LOL
 2014-04-08 14:31:08 IST Minor Check SIB F13 12 CXP 3
 2014-04-08 14:31:08 IST Minor Check SIB F13 6 CXP 14 Fbr Cbl
 2014-04-08 14:31:08 IST Minor Check SIB F13 6 CXP 12 Fbr Cbl
 2014-04-08 14:31:08 IST Minor Check SIB F13 6 CXP 8 Fbr Cbl
 2014-04-08 14:31:08 IST Minor Check SIB F13 6 CXP 6 Fbr Cbl
 2014-04-08 14:31:08 IST Minor Check SIB F13 6 CXP 4 Fbr Cbl
 2014-04-08 14:31:08 IST Minor Check SIB F13 6 CXP 2 Fbr Cbl
 2014-04-08 14:31:08 IST Minor Check SIB F13 6 CXP 0 Fbr Cbl
 2014-04-08 14:31:08 IST Minor SIB F13 6 CXP 14 LOL
 2014-04-08 14:31:08 IST Minor Check SIB F13 6 CXP 14
 2014-04-08 14:31:08 IST Minor SIB F13 6 CXP 12 LOL
 2014-04-08 14:31:08 IST Minor Check SIB F13 6 CXP 12
 2014-04-08 14:31:08 IST Major SIB F13 6 CXP 10 fault
 2014-04-08 14:31:08 IST Minor SIB F13 6 CXP 8 LOL
 2014-04-08 14:31:08 IST Minor Check SIB F13 6 CXP 8
 2014-04-08 14:31:08 IST Minor SIB F13 6 CXP 6 LOL
 2014-04-08 14:31:08 IST Minor Check SIB F13 6 CXP 6
 2014-04-08 14:31:08 IST Minor SIB F13 6 CXP 4 LOL
 2014-04-08 14:31:08 IST Minor Check SIB F13 6 CXP 4
 2014-04-08 14:31:08 IST Minor SIB F13 6 CXP 2 LOL
 2014-04-08 14:31:08 IST Minor Check SIB F13 6 CXP 2
 2014-04-08 14:31:08 IST Minor SIB F13 6 CXP 0 LOL
 2014-04-08 14:31:08 IST Minor Check SIB F13 6 CXP 0
 2014-04-08 14:31:08 IST Minor SIB F13 12 CXP 14 XC HSL Link Error
 2014-04-08 14:29:27 IST Minor LCC 0 Minor Errors
 2014-04-08 14:28:37 IST Major LCC 0 Major Errors
 2014-04-08 14:28:37 IST Major LCC 2 Major Errors
 2014-04-08 14:28:37 IST Minor LCC 2 Minor Errors
 2014-04-08 14:28:24 IST Major SIB F2S 4/6 Absent
 2014-04-08 14:28:24 IST Major SIB F2S 4/4 Absent
 2014-04-08 14:28:24 IST Major SIB F2S 4/2 Absent
 2014-04-08 14:28:24 IST Major SIB F2S 4/0 Absent
 2014-04-08 14:28:24 IST Major SIB F2S 3/6 Absent
 2014-04-08 14:28:24 IST Major SIB F2S 3/4 Absent
 2014-04-08 14:28:24 IST Major SIB F2S 3/2 Absent
 2014-04-08 14:28:24 IST Major SIB F2S 3/0 Absent
 2014-04-08 14:28:24 IST Major SIB F13 9 Absent
 2014-04-08 14:28:24 IST Major SIB F13 8 Absent

```

2014-04-08 14:28:24 IST Major SIB F13 7 Absent
2014-04-08 14:28:24 IST Major SIB F13 4 Absent
2014-04-08 14:28:24 IST Major SIB F13 1 Absent
2014-04-08 14:28:22 IST Major PEM 0 Input Failure
2014-04-08 14:28:22 IST Major PEM 0 Not OK

```

lcc0-re0:

12 alarms currently active

Alarm time	Class	Description
2014-04-08 14:36:08 IST	Minor	CB 1 M/S Switch Changed
2014-04-08 14:36:08 IST	Minor	CB 1 CHASSIS ID Changed
2014-04-08 14:35:43 IST	Minor	CB 0 M/S Switch Changed
2014-04-08 14:35:43 IST	Minor	CB 0 CHASSIS ID Changed
2014-04-08 14:29:30 IST	Minor	SIB 4 Not Online
2014-04-08 14:29:30 IST	Minor	SIB 3 Not Online
2014-04-08 14:29:30 IST	Minor	SIB 2 Not Online
2014-04-08 14:29:24 IST	Major	Rear Fan Tray Failure
2014-04-08 14:29:24 IST	Major	Front Bottom Fan Tray Improper for Platform
2014-04-08 14:29:24 IST	Major	Front Top Fan Tray Improper for Platform
2014-04-08 14:28:37 IST	Major	SIB 4 Absent
2014-04-08 14:28:37 IST	Major	SIB 3 Absent

lcc2-re0:

12 alarms currently active

Alarm time	Class	Description
2014-04-08 14:36:02 IST	Minor	CB 1 M/S Switch Changed
2014-04-08 14:36:02 IST	Minor	CB 1 CHASSIS ID Changed
2014-04-08 14:35:42 IST	Minor	CB 0 M/S Switch Changed
2014-04-08 14:34:42 IST	Minor	CB 0 CHASSIS ID Changed
2014-04-08 14:29:29 IST	Minor	SIB 0 CXP 7 Unsupported Optics
2014-04-08 14:29:27 IST	Major	Front Bottom Fan Tray Improper for Platform
2014-04-08 14:29:27 IST	Major	Front Top Fan Tray Improper for Platform
2014-04-08 14:29:25 IST	Minor	SIB 4 Not Online
2014-04-08 14:29:25 IST	Minor	SIB 3 Not Online
2014-04-08 14:28:47 IST	Major	PEM 0 Not OK
2014-04-08 14:28:36 IST	Major	SIB 2 Absent
2014-04-08 14:28:36 IST	Minor	Host 0 Boot from alternate media

lcc6-re0:

2 alarms currently active

Alarm time	Class	Description
2013-11-06 04:03:56 PST	Minor	SIB 1 CXP 0 XC HSL Link Error
2013-11-06 03:49:32 PST	Major	PEM 1 Not OK

show chassis alarms (Alarms on a T4000 Router After the enhanced-mode Statement is Enabled)

To enable improved virtual private LAN service (VPLS) MAC address learning on T4000 routers, you must include the `enhanced-mode` statement at the `[edit chassis network-services]` hierarchy level and reboot the router. When router reboots, only the T4000 Type 5 FPCs are required to be present on the router. If there are any other FPCs (apart from T4000 Type 5 FPCs) on the T4000 router, such FPCs become offline, and FPC misconfiguration alarms are generated. The `show chassis alarm` command output displays FPC misconfiguration (FPC `fpc-slot` misconfig) as the reason for the generation of the alarms.

```
user@host> show chassis alarms
2 alarms currently active
Alarm time          Class Description
2011-10-22 10:10:47 PDT Major FPC 1 misconfig
2011-10-22 10:10:46 PDT Major FPC 0 misconfig
```

show chassis alarms (Backup Routing Engine)

```
user@host> show chassis alarms
2 alarms are currently active
Alarm time          Class Description
2005-04-07 10:12:22 PDT Minor Host 1 Boot from alternate media
2005-04-07 10:11:54 PDT Major Host 1 compact-flash missing in Boot List
```

show chassis alarms (EX Series Switch)

```
user@switch> show chassis alarms

4 alarms currently active
Alarm time          Class Description
2014-03-12 15:36:09 UTC Minor Require a Fan Tray upgrade
2014-03-12 15:00:02 UTC Major PEM 0 Input Failure
```

```
2014-03-12 15:00:02 UTC Major PEM 0 Not OK
2014-03-12 14:59:51 UTC Minor Host 1 Boot from alternate media
```

show chassis alarms (Alarms Active on the QFX Series and OCX Series Switches)

```
user@switch> show chassis alarms
1 alarms currently active
Alarm time          Class Description
2012-03-05   2:10:24 UTC Major FPC 0 PEM 0 Airflow not matching Chassis Airflow
```

show chassis alarms node-device (Alarms Active on the QFabric System)

```
user@switch> show chassis alarms node-device
Test
node-device ED3694
3 alarms currently active
Alarm time          Class Description
2011-08-24 16:04:15 UTC Major Test:fte-0/1/2: Link down
2011-08-24 16:04:14 UTC Major Test:fte-0/1/0: Link down
2011-08-24 14:21:14 UTC Major Test PEM 0 is not supported/powered
```

show chassis alarms (Alarms Active on the QFabric System)

```
user@switch> show chassis alarms
IC-1:
-----
1 alarms currently active
Alarm time          Class Description
2011-08-24 16:04:15 UTC Minor Backup RE Active

Test:
-----
3 alarms currently active
Alarm time          Class Description
2011-08-24 16:04:15 UTC Major Test:fte-0/1/2: Link down
2011-08-24 16:04:14 UTC Major Test:fte-0/1/0: Link down
2011-08-24 14:21:14 UTC Major Test PEM 0 is not supported/powered
```



```
SNG-0:
```

```
NW-NG-0:
```

```
1 alarms currently active
```

Alarm time	Class	Description
2011-08-24 15:49:27 UTC	Major	Test PEM 0 is not supported/powerd

show chassis alarms (Alarms Active on an EX8200 Switch)

```
user@switch> show chassis alarms
```

```
6 alarms currently active
```

Alarm time	Class	Description
2010-12-02 19:15:22 UTC	Major	Fan Tray Failure
2010-12-02 19:15:22 UTC	Major	Fan Tray Failure
2010-12-02 19:15:14 UTC	Minor	Check CB 0 Fabric Chip 1 on Plane/FPC/PFE: 1/5/0, 1/5/1, 1/5/2, 1/5/3, 1/7/0, 1/7/1, 1/7/2, 1/7/3, 2/5/0, 2/5/1, ...
2010-12-02 19:15:14 UTC	Minor	Check CB 0 Fabric Chip 0 on Plane/FPC/PFE: 1/5/0, 1/5/1, 1/5/2, 1/5/3, 1/7/0, 1/7/1, 1/7/2, 1/7/3, 2/5/0, 2/5/1, ...
2010-12-02 19:14:18 UTC	Major	PSU 1 Output Failure
2010-12-02 19:14:18 UTC	Minor	Loss of communication with Backup RE

show chassis alarms (EX9251 Switch)

```
user@switch> show chassis alarms
```

```
2 alarms currently active
```

Alarm time	Class	Description
2018-03-08 05:13:10 PST	Major	PEM 0 Not Powered
2018-03-08 05:13:10 PST	Major	Fan Tray 2 is not present

show chassis alarms (EX9253 Switch)

```
user@switch> show chassis alarms
```

6 alarms currently active

Alarm time	Class	Description
2018-03-07 01:09:01 PST	Major	Power Budget:Insufficient Power
2018-03-06 23:56:34 PST	Minor	Loss of communication with Backup RE
2018-02-15 00:48:10 PST	Minor	PEM 3 Not Present
2018-02-15 00:48:10 PST	Minor	PEM 2 Not Present
2018-02-15 00:48:07 PST	Major	PEM 4 Not Powered
2018-02-15 00:48:07 PST	Major	PEM 1 Not Powered

show chassis alarms (MX Series for PFE reset)

```
user@host> show chassis alarms
1 alarm currently active
Alarm time          Class Description
2021-01-04 11:20:42 PST Major FPC 0 PFE 0 reset initiated
```

show chassis alarms (MX Series for PFE reset error)

```
user@host> show chassis alarms
1 alarm currently active
Alarm time          Class Description
2021-01-04 11:20:42 PST Major FPC 0 PFE 0 reset error
```

show chassis alarms (Alarms Active on a PTX5000 Packet Transport Router)

```
user@host> show chassis alarms

23 alarms currently active
Alarm time          Class Description
2011-07-12 16:22:05 PDT Minor No Redundant Power for Rear Chassis
2011-07-12 16:22:05 PDT Major PDU 0 PSM 1 Not OK
2011-07-12 16:21:57 PDT Minor No Redundant Power for Fan 0-2
2011-07-12 16:21:57 PDT Major PDU 0 PSM 0 Not OK
2011-07-12 15:56:06 PDT Major PDU 1 PSM 2 Not OK
2011-07-12 15:56:06 PDT Minor No Redundant Power for FPC 0-7
2011-07-12 15:56:06 PDT Major PDU 0 PSM 3 Not OK
```

```
2011-07-12 15:28:20 PDT Major PDU 0 PSM 2 Not OK
2011-07-12 15:19:14 PDT Minor Backup RE Active
```

show chassis alarms (Mix of PDUs Alarm on a PTX5000 Packet Transport Router with FPC2-PTX-P1A)

All PDUs installed on a PTX5000 router must be of the same type. The Mix of PDUs or Power Manager Non Operational alarm is raised when different types of PDUs are installed on a PTX5000 router.

```
user@host> show chassis alarms
15 alarms currently active
Alarm time          Class Description
2013-03-19 23:03:53 PDT Minor No Redundant Power
2013-03-19 23:03:48 PDT Minor Mix of PDUs
2013-03-19 23:03:47 PDT Minor PDU 1 PSM 3 Absent
2013-03-19 23:03:47 PDT Minor PDU 1 PSM 2 Absent
2013-03-19 23:03:47 PDT Minor PDU 1 PSM 1 Absent
2013-03-19 23:03:47 PDT Minor PDU 1 PSM 0 Absent
2013-03-19 23:03:46 PDT Major No CG Online
```

show chassis alarms (PDU Converter Failed Alarm on a PTX5000 Packet Transport Router with FPC2-PTX-P1A)

The PDU Converter Failed alarm is raised when one or more 36 V booster converter of a DC PDU fails. If two or more 36 V booster converter fails, fan trays fail and the router might get over heated. Therefore, when this alarm is raised, check the PDU and replace it, if required.

```
user@host> show chassis alarms
11 alarms currently active
Alarm time          Class Description
2013-12-11 22:14:13 PST Minor No Redundant Power for System
2013-12-11 22:14:10 PST Major PDU 0 PSM 7 Not OK
2013-12-11 22:14:10 PST Major PDU 0 PSM 6 Not OK
2013-12-11 22:14:10 PST Major PDU 0 PSM 5 Not OK
2013-12-11 22:14:10 PST Major PDU 0 PSM 4 Not OK
2013-12-11 22:14:10 PST Major PDU 0 PSM 3 Not OK
2013-12-11 22:14:10 PST Major PDU 0 PSM 2 Not OK
2013-12-11 22:14:10 PST Major PDU 0 PSM 1 Not OK
2013-12-11 22:14:10 PST Major PDU 0 PSM 0 Not OK
```

```
2013-12-11 22:14:10 PST Major PDU 0 Not OK
2013-12-11 22:14:01 PST Major PDU 0 Converter Failed
```

show chassis alarms (No Power for System Alarm on a PTX5000 Packet Transport Router with FPC2-PTX-P1A)

```
user@host> show chassis alarms
8 alarms currently active
Alarm time          Class Description
2013-11-19 01:58:41 PST Major No Power for System
2013-11-19 01:58:37 PST Major PDU 0 PSM 1 Not OK
2013-11-19 01:56:46 PST Major PDU 0 PSM 2 Not OK
2013-11-19 01:54:26 PST Major PDU 0 PSM 3 Not OK
2013-11-19 01:53:30 PST Major PDU 1 PSM 3 Not OK
2013-11-19 01:53:29 PST Major PDU 1 PSM 2 Not OK
2013-11-19 01:53:29 PST Major PDU 1 PSM 1 Not OK
2013-11-19 01:53:29 PST Major PDU 1 PSM 0 Not OK
```

show chassis alarms (Alarms Active on an ACX2000 Universal Metro Router)

```
user@host> show chassis alarms
7 alarms currently active
Alarm time          Class Description
2012-05-22 11:19:09 UTC Major xe-0/3/1: Link down
2012-05-22 11:19:09 UTC Major xe-0/3/0: Link down
2012-05-22 11:19:09 UTC Major ge-0/1/7: Link down
2012-05-22 11:19:09 UTC Major ge-0/1/6: Link down
2012-05-22 11:19:09 UTC Major ge-0/1/3: Link down
2012-05-22 11:19:09 UTC Major ge-0/1/2: Link down
2012-05-22 11:19:09 UTC Major ge-0/1/1: Link down
```

show chassis alarms (Active Alarm to Indicate Status of the Bad SCB Clock on MX Series)

```
user@host> show chassis alarms
1 alarm currently active
Alarm time          Class Description
2013-08-06 07:48:35 PDT Major CB 0 19.44 MHz clock failure
```

show chassis alarms (Alarms active on a PTX1000 Packet Transport Router)

```

user@host> show chassis alarms
2 alarms currently active
Alarm time          Class  Description
2004-08-10 00:55:49 UTC Major  PEM 1 Not Present
2004-08-10 00:55:49 UTC Major  PEM 0 Not Present

```

show chassis alarms (MX10003 Router)

If LCMD is down on the backup RE, then the following alarm is seen on the primary.

```

user@host> show chassis alarms
1 alarm currently active
Alarm time          Class  Description
2017-05-09 13:26:27 PDT Major  VMHost RE 1 host application failed

```

If LCMD is down on the primary, then following alarms are displayed.

```

user@host> show chassis alarms
3 alarms currently active
Alarm time          Class  Description
2017-05-10 14:12:21 PDT Major  VMHost RE 0 host application failed
2017-05-10 14:12:16 PDT Minor  LCM Peer Absent
2017-05-09 13:26:27 PDT Major  VMHost RE 1 host application failed

```

If the LCMD process is crashing on the primary, the system will switchover after one minute provided the backup RE LCMD connection is stable. The system will not switchover under the following conditions: if the backup RE LCMD connection is unstable or if the current primary just gained primary role. When the primary has just gained primary role, the switchover happens only after four minutes.

The LCM peer connection un-stable alarm is raised when the LCMD-CHASD IPC communication flaps three times within a small interval of two to three minutes. Once LCM peer connection un-stable alarm is raised, the connection status is monitored for two minutes.

```

user@host> show chassis alarms
7 alarms currently active
Alarm time          Class  Description
2017-05-29 10:12:17 PDT Minor  LCM Peer Connection un-stable

```

```

2017-05-29 09:04:17 PDT Minor PEM 8 Not Powered
2017-05-29 09:04:17 PDT Minor PEM 9 Not Powered
2017-05-29 09:04:17 PDT Minor PEM 7 Not Powered
2017-05-29 09:04:17 PDT Minor PEM 3 Not Powered
2017-05-29 09:04:17 PDT Minor PEM 0 Not Powered
2017-05-29 09:04:08 PDT Minor Loss of communication with Backup RE

```

If there are no more connection flaps within this two minutes time interval, the LCM peer connection un-stable alarm is cleared.

```

6 alarms currently active
Alarm time          Class Description
2017-05-29 09:04:17 PDT Minor PEM 8 Not Powered
2017-05-29 09:04:17 PDT Minor PEM 9 Not Powered
2017-05-29 09:04:17 PDT Minor PEM 7 Not Powered
2017-05-29 09:04:17 PDT Minor PEM 3 Not Powered
2017-05-29 09:04:17 PDT Minor PEM 0 Not Powered
2017-05-29 09:04:08 PDT Minor Loss of communication with Backup RE

```

A major alarm is raised even if there is on one PLL lock error, and this alarm can be cleared only through an FPC restart.

```

user@host> show chassis alarms
4 alarms currently active
Alarm time          Class Description
2017-02-16 09:06:06 PDT Major FPC 0 Major Errors
2017-02-16 09:08:40 PDT Major FPC 1 Major Errors
2017-02-16 09:11:47 PST Minor Fan Tray 3 Pair 1 Outer Fan running at over speed
2017-02-16 09:11:47 PST Minor Fan Tray 3 Pair 1 Inner Fan running at over speed

```

show chassis alarms (Alarms active on a MX10008 Router)

```

user@host> show chassis alarms
13 alarms currently active
Alarm time          Class Description
2018-07-17 05:48:08 PDT Major FPC 2 I2C Failure
2018-07-17 05:47:02 PDT Minor Mixed Master and Backup RE types
2018-07-17 05:47:01 PDT Major Fan Tray 0 Fan 5 Failed
2018-07-17 05:47:01 PDT Major Fan Tray 0 Fan 4 Failed
2018-07-17 05:47:01 PDT Minor PEM 5 Not Powered

```

```

2018-07-17 05:47:01 PDT Minor PEM 5 Feed 2 has no input source
2018-07-17 05:47:01 PDT Minor PEM 5 Feed 1 has no input source
2018-07-17 05:47:01 PDT Minor PEM 4 Not Powered
2018-07-17 05:47:01 PDT Minor PEM 4 Feed 2 has no input source
2018-07-17 05:47:01 PDT Minor PEM 4 Feed 1 has no input source
2018-07-17 05:47:01 PDT Minor PEM 3 Not Powered
2018-07-17 05:47:01 PDT Minor PEM 3 Feed 2 has no input source
2018-07-17 05:47:01 PDT Minor PEM 3 Feed 1 has no input source

```

show chassis alarms (ACX710 Router)

```

user@host> show chassis alarms
Alarm time          Class Description
2011-01-23 21:42:46 PST Major PTP Local Clock OOS
2011-01-23 21:42:46 PST Major PTP No Foreign Master
2011-01-23 21:42:46 PST Major Chassis Loss of all Equipment Clock Synch References
2011-01-23 21:42:46 PST Major Chassis Loss of Equipment Clock Synch Reference 1
2011-01-23 21:42:46 PST Major Chassis Loss of Equipment Clock Synch Reference 2
2011-01-23 21:42:46 PST Major Equipment Clock QL Below Threshold
2011-01-23 21:42:46 PST Major TOD Input A Signal Fail
2011-01-23 21:42:46 PST Major 1PPS lost
2011-01-23 21:42:46 PST Major SyncE Port incompatible Media Type

```

show chassis alarms (MX10008, MX10016, PTX10008, PTX10016, QFX10008,QFX10016) (Junos OS Release)

Starting Junos OS Evolved Release 21.2R1, if PEM or FET Failure detected, a major alarm is raised, and the identified PSM will shutdown or raise alarms as per predefined configuration in the `set chassis thermal-events fet-failure-check` command.

For FET failure detection and action, the `show chassis alarm` output displays a major alarm and information if PSM is shutdown.

For example, for the `show chassis` configuration:

```

user@root> show chassis thermal-health-check
{
    fet-failure-check;
}

```

```

        action-onfail auto-shutdown;
    }

```

The output is displayed as follows:

```
user@root> show chassis alarms
```

```

Alarm time           Class Description
2007-04-10 02:33:11 PDT Minor No Redundant Power for System
2007-04-10 02:33:08 PDT Minor PDU 1 PSM 4 Thermal Check brought it Down
2007-04-10 02:33:08 PDT Major PDU 1 PSM 4 Not OK
2007-04-10 02:33:08 PDT Minor PDU 0 PSM 4 Thermal Check brought it Down
2007-04-10 02:33:08 PDT Major PDU 0 PSM 4 Not OK
2007-04-10 02:32:03 PDT Minor PDU 1 PSM 3 Thermal Check brought it Down
2007-04-10 02:32:03 PDT Major PDU 1 PSM 3 Not OK
...
...

```

show chassis alarms (ACX7024)

On ACX7024 device, when edit chassis pem minimum is set to 1, The following output is displayed. The PSM absent alarm is removed only after a reboot:

```
user@root> show chassis alarms
```

```
4 alarms currently active
```

```

Alarm time           Class Description
2022-05-15 09:12:31 PDT Major No Redundant Power for System
2022-05-15 09:12:31 PDT Major PSM 1 Input1 Failed
2022-05-15 09:12:31 PDT Major PSM 1 Input Failed
2022-05-15 09:12:34 PDT Major PSM 0 Absent
2022-06-04 05:30:11 PDT Minor RE 0 Secure boot disabled or not enforced

```

When the default PSU 1+1 redundancy mode is active, the following output is displayed:

```
user@root> show chassis alarms
```

```
6 alarms currently active
```

```

Alarm time           Class Description
2022-05-15 09:12:31 PDT Major No Redundant Power for System
2022-05-15 09:12:31 PDT Major PSM 1 Input1 Failed
2022-05-15 09:12:31 PDT Major PSM 1 Input Failed

```



```

2022-06-04 05:30:19 PDT Major PSM 0 Absent
2022-06-04 05:30:11 PDT Minor RE 0 Secure boot disabled or not enforced
2022-06-04 05:31:54 PDT Major chassis No Redundant Power

```

Release Information

Command introduced before Junos OS Release 7.4.

sfc option introduced in Junos OS Release 9.6 for the TX Matrix Plus router.

satellite option introduced in Junos OS Release 14.2R3 for Junos Fusion.

Command introduced in Junos OS Release 18.2R1 for EX9253 Switches and MX10008 Universal Routing Platforms.

RELATED DOCUMENTATION

[Configuring an RMON Alarm Entry and Its Attributes](#)

[Chassis Conditions That Trigger Alarms](#)

show chassis environment

IN THIS SECTION

- [Syntax \(T320, T640, T1600, and T4000 Routers\) | 279](#)
- [Syntax \(TX Matrix Routers\) | 279](#)
- [Syntax \(TX Matrix Plus Routers\) | 280](#)
- [Syntax \(MX Series Routers\) | 280](#)
- [Syntax \(MX104 Universal Routing Platforms\) | 280](#)
- [Syntax \(MX150 Router Appliance\) | 280](#)
- [Syntax \(MX2010, MX2020, and MX2008 Universal Routing Platforms\) | 281](#)
- [Syntax \(MX10003 and MX204 Universal Routing Platforms\) | 281](#)
- [Syntax \(EX8200 Switches\) | 281](#)
- [Syntax \(EX Series Switches except EX8200\) | 282](#)
- [Syntax \(QFX Series\) | 282](#)

- Syntax (OCX Series) | 282
- Syntax (PTX Series Packet Transport Routers) | 282
- Syntax (ACX Series Universal Metro Routers, ACX7509) | 283
- Syntax (ACX5048 and ACX5096 Routers) | 283
- Syntax (ACX500 Routers) | 283
- Syntax (Junos OS Evolved) | 283
- Description | 284
- Options | 284
- Required Privilege Level | 287
- Output Fields | 287
- Sample Output | 290
- show chassis environment (ACX7509) | 394
- Release Information | 397

Syntax (T320, T640, T1600, and T4000 Routers)

```
show chassis environment
<cb cb-slot-number>
<feb feb-slot-number>
<fpc fpc-slot-number>
<fpm>
<pem pem-slot-number>
<routing-engine re-slot-number>
<scg scg-slot-number>
<sib sib-slot-number>
```

Syntax (TX Matrix Routers)

```
show chassis environment
<lcc number | scc>
```

Syntax (TX Matrix Plus Routers)

```
show chassis environment
<cb cb-slot-number>
<cip cip-slot-number>
<fpc fpc-slot-number>
<fpm>
<lcc number>
<pem pem-slot-number>
<routing-engine re-slot-number>
<scg scg-slot-number>
< sfc number>
<sib sib-slot-number>
```

Syntax (MX Series Routers)

```
show chassis environment
<all-members>
<local>
<member member-id>
```

Syntax (MX104 Universal Routing Platforms)

```
show chassis environment
<cb>
<pem pem-slot-number>
<routing-engine re-slot-number>
```

Syntax (MX150 Router Appliance)

```
show chassis environment
<pem pem-slot-number>
<routing-engine re-slot-number>
```

Syntax (MX2010, MX2020, and MX2008 Universal Routing Platforms)

```
show chassis environment
<adc adc-slot-number>
<all-members>
<cb cb-slot-number>
<fan fantray-slot-number>
<fpc fpc-slot-number>
<fpm>
<local>
<member member-id>
<monitored>
<psm psm-slot-number>
<routing-engine re-slot-number>
<sfb sfb-slot-number>
<satellite [fpc-slot slot-id |device-alias alias-name]>
```

Syntax (MX10003 and MX204 Universal Routing Platforms)

```
show chassis environment
<cb cb-slot-number>
<fpc fpc-slot-number>
<pem pem-slot-number>
<routing-engine re-slot-number>
```

Syntax (EX8200 Switches)

```
show chassis environment
<all-members>
<cb cb-slot-number>
<fpc fpc-slot-number>
<local>
<member member-id>
<psu psu-slot-number>
<routing-engine re-slot-number>
```

Syntax (EX Series Switches except EX8200)

```
show chassis environment
<all-members>
<fpc fpc-slot-number>
<local>
<member member-id>
<power-supply-unit>
<routing-engine>
<satellite [fpc-slot slot-id |device-alias alias-name]>
```

Syntax (QFX Series)

```
show chassis environment
<cb slot-number <interconnect-device name>>
<fpc slot-number <interconnect-device name>>
<interconnect-device name <slot-number>
<node-device name>
<pem slot-number (interconnect-device name slot-number) | (node-device name)>
<routing-engine name <interconnect-device name slot-number>>
```

Syntax (OCX Series)

```
show chassis environment
```

Syntax (PTX Series Packet Transport Routers)

```
show chassis environment
<cb cb-slot-number>
<ccg ccg-slot-number >
<fpc fpc-slot-number>
<fpm>
<monitored>
<pdu pdu-slot-number>
<routing-engine re-slot-number>
<sib sib-slot-number>
```

Syntax (ACX Series Universal Metro Routers, ACX7509)

```
show chassis environment
<cb cb-slot-number>
<feb feb-slot-number>
<pem pem-slot-number>
<routing-engine re-slot-number>
```

Syntax (ACX5048 and ACX5096 Routers)

```
show chassis environment
<fpc slot-number>
<pem>
<routing-engine>
```

Syntax (ACX500 Routers)

```
show chassis environment
<cb cb-slot-number>
<routing-engine re-slot-number>
```

Syntax (Junos OS Evolved)

```
show chassis environment
<cb cb-slot-number>
<fan fan-slot-number>
<fpc fpc-slot-number>
<fpm>
<monitored>
<psm psm-slot-number>
<routing-engine routing-engine-slot-number>
<sib sib-slot-number>
```

Description

Display environmental information about the router or switch chassis, including the temperature and information about the fans, power supplies, and Routing Engine.

In addition, on ACX4000 routers, display temperature information about the different channels of a Modular Interface Card (MIC). The number of channels displayed depends on the type of MIC installed.

Starting with Junos OS Release 14.1, the `show chassis environment` *cb cb-slot-number | ccg ccg-slot-number | fpc fpc-slot-number | fpm | monitored | pdu pdu-slot-number | routing-engine re-slot-number | sib sib-slot-number* operational mode command output displays environmental information for the new DC power supply module (PSM) and power distribution unit (PDU) that are added to provide power to the high-density FPC (FPC2-PTX-P1A) and other components in a PTX5000 Packet Transport Router.

Options

none	Display environmental information about the router or switch chassis. On a TX Matrix router, display environmental information about the TX Matrix router and its attached T640 routers. On a TX Matrix Plus router, display environmental information about the TX Matrix Plus router and its attached routers.
all-members	(MX Series routers and EX Series switches only) (Optional) Display chassis environmental information for all the members of the Virtual Chassis configuration.
adc adc-slot-number	(MX2010, MX2020, and MX2008 routers only) (Optional) Display chassis environmental information for the adapter cards. For MX2020 routers, replace <i>adc-slot-number</i> with a value from 0 through 19. For MX2010 and MX2008 routers, replace <i>adc-slot-number</i> with a value from 0 through 9.
cb cb-slot-number	(ACX Series Universal Metro Routers, EX Series switches, M120, M320, and M40e routers, MX Series routers, MX2020 routers, MX2010 routers, MX2008 routers, PTX Series Packet Transport Routers, QFX Series, and T Series routers, and TX Matrix Plus routers only) (Optional) Display chassis environmental information for the Control Board. On devices other than EX Series switches, replace <i>cb-slot</i> with 0 or 1.
feb feb-slot-number	(ACX Series Universal Metro Routers, ACX7509 routers only) (Optional) Display chassis environmental information for the FEB.
cip cip-slot-number	(TX Matrix Plus routers only) (Optional) Display chassis environmental information for the Connection Interface Panel (CIP). Replace the <i>cip-slot-number</i> variable with a value of 0 or 1.

cb interconnect-device <i>name</i>	(QFabric systems only) (Optional) Display chassis environmental information for the Control Board on an Interconnect device.
ccg <i>ccg-slot-number</i>	(PTX Series only) (Optional) Display chassis environmental information for the Centralized Clock Generator. Replace <i>cb-slot</i> with a value of 0 or 1.
fan <i>fantray-slot-number</i>	(MX2010, MX2020, and MX2008 routers only) (Optional) Display chassis environmental information for the fan trays. Replace <i>fantray-slot-number</i> with a value from 0 through 3.
fpc <i>fpc-slot</i>	(EX Series switches, M120, M320, and M40e routers, MX Series routers, MX2010 routers, MX2020 routers, MX2008 routers, PTX Series Packet Transport Routers, QFX Series, QFX3500 switches, QFabric systems, T Series routers, and TX Matrix Plus routers) (Optional) Display chassis environmental information for a specified Flexible PIC Concentrator. For MX2010 and MX2008 routers, replace <i>fpc-slot</i> with a value from 0 through 9. For MX2020 routers, replace <i>fpc-slot</i> with a value from 0 through 19. For information about FPC numbering, see <i>show chassis environment fpc</i> . On a QFabric system, display chassis environmental information for a specified Flexible PIC Concentrator on an Interconnect device. On an EX Series switch, display chassis environmental information for a specified Flexible PIC Concentrator; see the hardware documentation for your switch for information on FPC numbering. On a TX Matrix Plus router with 3D SIBs replace <i>fpc-slot</i> with a value from 0 through 63.
fpm	(M120, M320, and M40e routers, MX2010 routers, MX2020 routers, MX2008 routers, PTX Series, Packet Transport Routers, T Series routers, and TX Matrix Plus routers only) (Optional) Display chassis environmental information for the craft interface (FPM).
interconnect-device <i>name</i>	(QFabric systems only) (Optional) Display chassis environmental information for the Interconnect device.
lcc <i>number</i>	(TX Matrix routers and TX Matrix Plus routers only) (Optional) Line-card chassis number. Replace <i>number</i> with the following values depending on the LCC configuration: <ul style="list-style-type: none"> • 0 through 3, when T640 routers are connected to a TX Matrix router in a routing matrix. • 0 through 3, when T1600 routers are connected to a TX Matrix Plus router in a routing matrix.

- 0 through 7, when T1600 routers are connected to a TX Matrix Plus router with 3D SIBs in a routing matrix.
- 0, 2, 4, or 6, when T4000 routers are connected to a TX Matrix Plus router with 3D SIBs in a routing matrix.

local	(MX Series routers and EX Series switches only) (Optional) Display chassis environmental information for the local Virtual Chassis member.
member <i>member-id</i>	(MX Series routers and EX Series switches only) (Optional) Display chassis environmental information for the specified member of the Virtual Chassis configuration. On MX Series routers, replace <i>member-id</i> with a value of 0 or 1. For EX Series switches, see <i>member</i> for member ID values.
monitored	(MX2020 routers and PTX Series Packet Transport Routers only) (Optional) Display chassis environmental information for monitored temperatures only. Temperatures that are not included in temperature alarm computations are not displayed.
node-device <i>name</i>	(QFabric systems only) (Optional) Display chassis environmental information for the Node device.
pdu <i>pdu-slot-number</i>	(PTX Series only) (Optional) Display chassis environmental information for the specified power distribution unit.
pem	(QFX3500 switches and QFabric systems only) (Optional) Display chassis environmental information for the Power Entry Module on the specified Interconnect device or Node device.
pem <i>pem-slot-number</i>	(ACX Series Universal Metro Routers, M120, M320, and M40e routers, MX Series routers, MX104 routers, QFX Series, and T Series routers only) (Optional) Display chassis environmental information for the Power Entry Module on the specified Power Entry Module. For information about the options, see <i>show chassis environment pem</i> .
psm <i>psm-slot-number</i>	(MX2010, MX2020, and MX2008 routers only) (Optional) Display chassis environmental information for the power supply module. For MX2020 routers, replace <i>psm-slot-number</i> with a value from 0 through 17. For MX2010 and MX2008 routers, replace <i>psm-slot-number</i> with a value from 0 through 8.
psu <i>psu-slot-number</i>	(EX Series switches only) (Optional) Display chassis environmental information for a specified power supply.
routing-engine	(QFX3500 switches and QFabric systems only) (Optional) Display chassis environmental information for the Routing Engine on the specified Interconnect

device. For QFX5700 with Junos OS Evolved, details about CPU and memory utilization are also displayed for RCB slot 0 and slot 1.

routing-engine <i>re-slot-number</i>	(Optional) Display chassis environmental information for the specified Routing Engine. For information about the options, see <i>show chassis environment routing-engine</i> .
satellite [fpc-slot <i>slot-id</i> device-alias <i>alias-name</i>]	(Junos Fusion only)(Optional) Display chassis environmental information for the specified satellite device in a Junos Fusion, or for all satellite devices in the Junos Fusion if no satellite devices are specified.
scg	(T Series routers only) (Optional) Display chassis environmental information about the SONET Clock Generator.
scc	(TX Matrix routers only) (Optional) Display chassis environmental information about the TX Matrix router (switch-card chassis).
sfb <i>sfb-slot-number</i>	(MX2010, MX2020, and MX2008 routers only) (Optional) Display chassis environmental information for the switch fabric board. Replace <i>sfb-slot-number</i> with a value from 0 through 7.
sfc <i>number</i>	(TX Matrix Plus routers only) (Optional) Display chassis environmental information about the respective TX Matrix Plus router (switch-fabric chassis). Replace <i>number</i> variable with 0.
sib <i>sib-slot-number</i>	(M320 routers, PTX Series Packet Transport Routers, and T Series routers only) (Optional) Display chassis environmental information about the specified switch interface board. For information about the options, see show chassis environment sib .

Required Privilege Level

view

Output Fields

[Table 14 on page 288](#) lists the output fields for the `show chassis environment` command. Output fields are listed in the approximate order in which they appear.

Table 14: show chassis environment Output Fields

Field Name	Field Description
Class	<p>Information about the category or class of chassis component:</p> <ul style="list-style-type: none"> • Power: Power information: <ul style="list-style-type: none"> • (M5, M10, M20, and M40 routers and EX Series switches only) Power supply status: OK, Testing, (during initial power-on), Failed, or Absent. • (M7i, M10i, M40e, M120, M160, M320, and T Series routers and EX Series switches only) Power Entry Modules status: OK, Testing, (during initial power-on), Check, Failed, or Absent. • (PTX Series only) Power information is reported in PDU or PSM combinations. The status is: OK, Testing, (during initial power-on), Check, Failed, or Absent. • Temp: Temperature of air flowing through the chassis in degrees Celsius (C) and Fahrenheit (F). <ul style="list-style-type: none"> • On PTX Series Packet Transport Routers and MX2010, MX2020, and MX2008 Routers, multiple cooling zones are supported. FRU temperatures in each zone are coordinated with the fan speed of fan trays in those zones. • EX2200 switches have a side-to-rear cooling system. The Local Intake temperature is measured by the sensor on the right side of the chassis, and the Remote Intake temperature is measured by the sensor on the left side of the chassis. • Pic: On ACX4000 routers, multiple temperature channels on a MIC. The status is: OK and the Measurement is in degrees Celsius (C) and Fahrenheit (F). • Fan: Fan status: OK, Testing (during initial power-on), Failed, or Absent. <p>On PTX Series Packet Transport Routers and MX2010, MX2020, and MX2008 Routers, multiple fan trays are supported. Fan status is reported in Fan Tray or Fan combinations. Measurement indicates actual fan RPM (PTX and MX2010, MX2020, and MX2008 Routers only).</p> • Misc: Information about other components of the chassis. <ul style="list-style-type: none"> • On some routers, this field indicates the status of one or more additional components.

Table 14: show chassis environment Output Fields *(Continued)*

Field Name	Field Description
	<ul style="list-style-type: none"> • On the M40e, M160, and M320 router, Misc includes CIP (Connector Interface Panel). OK indicates that the CIP is present. Absent indicates that the CIP is not present. • On T Series routers, Misc includes CIP and SPMB (Switch Processor Mezzanine Board). OK indicates that the CIP or SPMB is present. Absent indicates that the CIP or SPMB is not present. • On PTX Series Packet Transport Routers, Misc includes the SPMB (Switch Processor Mezzanine Board). The SPMB is located on the control boards. OK indicates that the control board is present. Absent indicates that the control board is not present.
Item	<p>(MX2010, MX2020, and MX2008 Routers) Information about the chassis component: Routing Engines, Controls Boards (CBs), Switch Fabric Boards (SFBs), PICs, Flexible PIC Concentrators (FPCs), and Adapter Cards (ADCs).</p> <p>(MX104 Routers) Information about the chassis components: Routing Engines, Control Board (CB), Power Entry Module (PEM), and Compact Forwarding Engine Board (AFEB).</p> <p>(QFabric Systems) Information about the chassis component: Control Boards, Routing Engines, Flexible PIC Concentrators (FPCs), and Power Entry Modules (PEMs), Node Devices, and Interconnect Devices.</p> <p>(QFX Series) Information about the chassis component: Flexible PIC Concentrators (FPCs), and Power Entry Modules (PEMs).</p>

Table 14: show chassis environment Output Fields (Continued)

Field Name	Field Description
Status	<p>(MX104, MX2010, MX2020, and MX2008 Routers) Status of the specified chassis component. For example, if the Class is Fan, the fan status can be:</p> <ul style="list-style-type: none"> • OK: The fans are operational. • Testing: The fans are being tested during initial power-on. • Failed: The fans have failed or the fans are not spinning. • Absent: The fan tray is not installed. <p>If the Class is Power, the power supply status can be:</p> <ul style="list-style-type: none"> • OK: The power component is operational. • Testing: The power component is being tested during initial power-on. • Check: There is insufficient power---that is, fewer than the minimum required feeds are connected. • Failed: The inputs leads have failed. • Absent: The power component is not installed.
Measurement	<p>(MX104, MX2010, MX2020, and MX2008 Routers) Dependant on the Class. For example, if the Class is Temp, indicates the temperature in degree Celsius and degrees Fahrenheit. If the Class is Fan, indicates actual fan RPM.</p>

Sample Output

show chassis environment (M5 Router)

```

user@host> show chassis environment
Class Item           Status  Measurement
Power Power Supply A   OK
Power Power Supply B   Absent
Temp  FPC 0              OK      30 degrees C / 86 degrees F
Temp  FEB              OK      33 degrees C / 91 degrees F
Temp  PS Intake         OK      27 degrees C / 80 degrees F

```

	PS Exhaust	OK	27 degrees C / 80 degrees F
	Routing Engine	OK	34 degrees C / 93 degrees F
Fans	Left Fan 1	OK	Spinning at normal speed
	Left Fan 2	OK	Spinning at normal speed
	Left Fan 3	OK	Spinning at normal speed
	Left Fan 4	OK	Spinning at normal speed
Misc	Craft Interface	OK	

show chassis environment (M7i Router)

```

user@host> show chassis environment
Class Item           Status      Measurement
Power Power Supply 0    OK
    Power Supply 1    Absent
Temp Intake             OK          22 degrees C / 71 degrees F
    FPC 0             OK          23 degrees C / 73 degrees F
    Power Supplies    OK          23 degrees C / 73 degrees F
    CFEB Intake       OK          24 degrees C / 75 degrees F
    CFEB Exhaust      OK          29 degrees C / 84 degrees F
    Routing Engine    OK          26 degrees C / 78 degrees F
Fans Fan 1              OK          Spinning at normal speed
    Fan 2              OK          Spinning at normal speed
    Fan 3              OK          Spinning at normal speed
    Fan 4              OK          Spinning at normal speed

```

show chassis environment (M10 Router)

```

user@host> show chassis environment
Class Item           Status      Measurement
Power Power Supply A    OK
    Power Supply B    Failed
Temp FPC 0              OK          36 degrees C / 96 degrees F
    FPC 1              OK          35 degrees C / 95 degrees F
    FEB                OK          34 degrees C / 93 degrees F
    PS Intake          OK          31 degrees C / 87 degrees F
    PS Exhaust         OK          34 degrees C / 93 degrees F
    Routing Engine     OK          35 degrees C / 95 degrees F
Fans Left Fan 1        OK          Spinning at normal speed

```

	Left Fan 2	OK	Spinning at normal speed
	Left Fan 3	OK	Spinning at normal speed
	Left Fan 4	OK	Spinning at normal speed
Misc	Craft Interface	OK	

show chassis environment (M10i Router)

```

user@host> show chassis environment
Class Item                Status      Measurement
Power Power Supply 0       OK
      Power Supply 1       OK
      Power Supply 2       Absent
      Power Supply 3       Absent
Temp  Intake                 OK          26 degrees C / 78 degrees F
      FPC 0                 OK          27 degrees C / 80 degrees F
      FPC 1                 OK          28 degrees C / 82 degrees F
      Lower Power Supplies OK          29 degrees C / 84 degrees F
      Upper Power Supplies OK          28 degrees C / 82 degrees F
      CFEB Intake           OK          27 degrees C / 80 degrees F
      CFEB Exhaust          OK          36 degrees C / 96 degrees F
      Routing Engine 0      OK          31 degrees C / 87 degrees F
      Routing Engine 1      OK          27 degrees C / 80 degrees F
Fans  Fan Tray 0 Fan 1       OK          Spinning at normal speed
      Fan Tray 0 Fan 2       OK          Spinning at normal speed
      Fan Tray 0 Fan 3       OK          Spinning at normal speed
      Fan Tray 0 Fan 4       OK          Spinning at normal speed
      Fan Tray 0 Fan 5       OK          Spinning at normal speed
      Fan Tray 0 Fan 6       OK          Spinning at normal speed
      Fan Tray 0 Fan 7       OK          Spinning at normal speed
      Fan Tray 0 Fan 8       OK          Spinning at normal speed
      Fan Tray 1 Fan 1       Absent
      Fan Tray 1 Fan 2       Absent
      Fan Tray 1 Fan 3       Absent
      Fan Tray 1 Fan 4       Absent
      Fan Tray 1 Fan 5       Absent
      Fan Tray 1 Fan 6       Absent
      Fan Tray 1 Fan 7       Absent
      Fan Tray 1 Fan 8       Absent

```

show chassis environment (M20 Router)

```

user@host> show chassis environment
Class Item                Status      Measurement
Power Power Supply A       OK
      Power Supply B       Absent
Temp  FPC 0                 OK          28 degrees C / 82 degrees F
      FPC 1                 OK          27 degrees C / 80 degrees F
      Power Supply A       OK          22 degrees C / 71 degrees F
      Power Supply B       Absent
      SSB 0                 OK          30 degrees C / 86 degrees F
      Backplane             OK          22 degrees C / 71 degrees F
      Routing Engine 0     OK          26 degrees C / 78 degrees F
      Routing Engine 1     Testing
Fans  Rear Fan             OK          Spinning at normal speed
      Front Upper Fan       OK          Spinning at normal speed
      Front Middle Fan      OK          Spinning at normal speed
      Front Bottom Fan      OK          Spinning at normal speed
Misc  Craft Interface      OK

```

show chassis environment (M40 Router)

```

user@host> show chassis environment
Class Item                Status      Measurement
Power Power Supply A       OK
      Power Supply B       Absent
Temp  FPC 3                 OK          24 degrees C / 75 degrees F
      FPC 6                 OK          26 degrees C / 78 degrees F
      SCB                   OK          26 degrees C / 78 degrees F
      Backplane @ A1        OK          28 degrees C / 82 degrees F
      Backplane @ A2        OK          23 degrees C / 73 degrees F
      Routing Engine        OK          26 degrees C / 78 degrees F
Fans  Top Impeller         OK          Spinning at normal speed
      Bottom impeller       OK          Spinning at normal speed
      Rear Left Fan         OK          Spinning at normal speed
      Rear Center Fan       OK          Spinning at normal speed
      Rear Right Fan        OK          Spinning at normal speed
Misc  Craft Interface      OK

```

show chassis environment (M40e Router)

```

user@host> show chassis environment
Class Item                Status      Measurement
Power PEM 0                OK
    PEM 1                  Absent
Temp PCG 0                  OK          44 degrees C / 111 degrees F
    PCG 1                  OK          47 degrees C / 116 degrees F
    Routing Engine 0      OK          40 degrees C / 104 degrees F
    Routing Engine 1      OK          37 degrees C / 98 degrees F
    MCS 0                  OK          45 degrees C / 113 degrees F
    MCS 1                  OK          42 degrees C / 107 degrees F
    SFM 0 SPP              OK          40 degrees C / 104 degrees F
    SFM 0 SPR              OK          44 degrees C / 111 degrees F
    SFM 1 SPP              OK          43 degrees C / 109 degrees F
    SFM 1 SPR              OK          45 degrees C / 113 degrees F
    FPC 0                  OK          38 degrees C / 100 degrees F
    FPC 1                  OK          40 degrees C / 104 degrees F
    FPC 2                  OK          38 degrees C / 100 degrees F
    FPC 4                  OK          34 degrees C / 93 degrees F
    FPC 5                  OK          43 degrees C / 109 degrees F
    FPC 6                  OK          41 degrees C / 105 degrees F
    FPC 7                  OK          43 degrees C / 109 degrees F
    FPM CMB                OK          28 degrees C / 82 degrees F
    FPM Display            OK          28 degrees C / 82 degrees F
Fans  Rear Bottom Blower   OK          Spinning at normal speed
    Rear Top Blower        OK          Spinning at normal speed
    Front Top Blower       OK          Spinning at normal speed
    Fan Tray Rear Left     OK          Spinning at normal speed
    Fan Tray Rear Right    OK          Spinning at normal speed
    Fan Tray Front Left    OK          Spinning at normal speed
    Fan Tray Front Right   OK          Spinning at normal speed
Misc  CIP                  OK

```

show chassis environment (M120 Router)

```

user@host> show chassis environment
Class Item                Status      Measurement
Temp PEM 0                OK

```

	PEM 1	OK	
	Routing Engine 0	OK	43 degrees C / 109 degrees F
	Routing Engine 1	OK	44 degrees C / 111 degrees F
	CB 0 Intake	OK	33 degrees C / 91 degrees F
	CB 0 Exhaust A	OK	36 degrees C / 96 degrees F
	CB 0 Exhaust B	OK	35 degrees C / 95 degrees F
	CB 1 Intake	OK	34 degrees C / 93 degrees F
	CB 1 Exhaust A	OK	38 degrees C / 100 degrees F
	CB 1 Exhaust B	OK	35 degrees C / 95 degrees F
	FEB 3 Intake	OK	35 degrees C / 95 degrees F
	FEB 3 Exhaust A	OK	37 degrees C / 98 degrees F
	FEB 3 Exhaust B	OK	39 degrees C / 102 degrees F
	FEB 4 Intake	OK	33 degrees C / 91 degrees F
	FEB 4 Exhaust A	OK	39 degrees C / 102 degrees F
	FEB 4 Exhaust B	OK	36 degrees C / 96 degrees F
	FPC 2 Exhaust A	OK	32 degrees C / 89 degrees F
	FPC 2 Exhaust B	OK	31 degrees C / 87 degrees F
	FPC 3 Exhaust A	OK	32 degrees C / 89 degrees F
	FPC 3 Exhaust B	OK	33 degrees C / 91 degrees F
	FPC 4 Exhaust A	OK	32 degrees C / 89 degrees F
	FPC 4 Exhaust B	OK	30 degrees C / 86 degrees F
Fans	Front Top Tray Fan 1	OK	Spinning at normal speed
	Front Top Tray Fan 2	OK	Spinning at normal speed
	Front Top Tray Fan 3	OK	Spinning at normal speed
	Front Top Tray Fan 4	OK	Spinning at normal speed
	Front Top Tray Fan 5	OK	Spinning at normal speed
	Front Top Tray Fan 6	OK	Spinning at normal speed
	Front Top Tray Fan 7	OK	Spinning at normal speed
	Front Top Tray Fan 8	OK	Spinning at normal speed
	Front Bottom Tray Fan 1	OK	Spinning at normal speed
	Front Bottom Tray Fan 2	OK	Spinning at normal speed
	Front Bottom Tray Fan 3	OK	Spinning at normal speed
	Front Bottom Tray Fan 4	OK	Spinning at normal speed
	Front Bottom Tray Fan 5	OK	Spinning at normal speed
	Front Bottom Tray Fan 6	OK	Spinning at normal speed
	Front Bottom Tray Fan 7	OK	Spinning at normal speed
	Front Bottom Tray Fan 8	OK	Spinning at normal speed
	Rear Top Tray Fan 1	OK	Spinning at normal speed
	Rear Top Tray Fan 2	OK	Spinning at normal speed
	Rear Top Tray Fan 3	OK	Spinning at normal speed
	Rear Top Tray Fan 4	OK	Spinning at normal speed
	Rear Top Tray Fan 5	OK	Spinning at normal speed
	Rear Top Tray Fan 6	OK	Spinning at normal speed

Rear Top Tray Fan 7	OK	Spinning at normal speed
Rear Top Tray Fan 8	OK	Spinning at normal speed
Rear Bottom Tray Fan 1	OK	Spinning at normal speed
Rear Bottom Tray Fan 2	OK	Spinning at normal speed
Rear Bottom Tray Fan 3	OK	Spinning at normal speed
Rear Bottom Tray Fan 4	OK	Spinning at normal speed
Rear Bottom Tray Fan 5	OK	Spinning at normal speed
Rear Bottom Tray Fan 6	OK	Spinning at normal speed
Rear Bottom Tray Fan 7	OK	Spinning at normal speed
Rear Bottom Tray Fan 8	OK	Spinning at normal speed

show chassis environment (M160 Router)

```

user@host> show chassis environment
Class Item                Status      Measurement
Power PEM 0                OK          PEM 1          Absent
Temp  PCG 0                  OK          45 degrees C / 113 degrees F
      PCG 1                  Absent
      Routing Engine 0      OK          35 degrees C / 95 degrees F
      Routing Engine 1      Absent
      MCS 0                  OK          50 degrees C / 122 degrees F
      SFM 0 SPP              OK          47 degrees C / 116 degrees F
      SFM 0 SPR              OK          49 degrees C / 120 degrees F
      SFM 1 SPP              OK          50 degrees C / 122 degrees F
      SFM 1 SPR              OK          50 degrees C / 122 degrees F
      SFM 2 SPP              OK          51 degrees C / 123 degrees F
      SFM 2 SPR              OK          52 degrees C / 125 degrees F
      SFM 3 SPP              OK          52 degrees C / 125 degrees F
      SFM 3 SPR              OK          48 degrees C / 118 degrees F
      FPC 0                  OK          45 degrees C / 113 degrees F
      FPC 6                  OK          43 degrees C / 109 degrees F
      FPM CMB                OK          31 degrees C / 87 degrees F
      FPM Display            OK          33 degrees C / 91 degrees F
Fans  Rear Bottom Blower    OK          Spinning at normal speed
      Rear Top Blower        OK          Spinning at normal speed
      Front Top Blower       OK          Spinning at normal speed
      Fan Tray Rear Left     OK          Spinning at normal speed
      Fan Tray Rear Right    OK          Spinning at normal speed
      Fan Tray Front Left    OK          Spinning at normal speed
      Fan Tray Front Right   OK          Spinning at normal speed

```

```
Misc CIP          OK
```

show chassis environment (M320 Router)

```
user@host> show chassis environment
Class Item          Status      Measurement
Temp PEM 0          Absent
    PEM 1          Absent
    PEM 2          OK
    PEM 3          OK
    Routing Engine 0 OK          33 degrees C / 91 degrees F
    Routing Engine 1 OK          32 degrees C / 89 degrees F
    CB 0           OK          36 degrees C / 96 degrees F
    CB 1           OK          36 degrees C / 96 degrees F
    SIB 0          OK          38 degrees C / 100 degrees F
    SIB 1          OK          29 degrees C / 84 degrees F
    SIB 2          OK          38 degrees C / 100 degrees F
    SIB 3          OK          41 degrees C / 105 degrees F
    FPC 0 Intake   OK          28 degrees C / 82 degrees F
    FPC 0 Exhaust  OK          40 degrees C / 104 degrees F
    FPC 1 Intake   OK          29 degrees C / 84 degrees F
    FPC 1 Exhaust  OK          39 degrees C / 102 degrees F
    FPC 2 Intake   OK          28 degrees C / 82 degrees F
    FPC 2 Exhaust  OK          38 degrees C / 100 degrees F
    FPC 3 Intake   OK          28 degrees C / 82 degrees F
    FPC 3 Exhaust  OK          39 degrees C / 102 degrees F
    FPC 6 Intake   OK          27 degrees C / 80 degrees F
    FPC 6 Exhaust  OK          39 degrees C / 102 degrees F
    FPC 7 Intake   OK          27 degrees C / 80 degrees F
    FPC 7 Exhaust  OK          42 degrees C / 107 degrees F
    FPM GBUS       OK          30 degrees C / 86 degrees F
Fan  Top Left Front fan OK          Spinning at normal speed
    Top Right Rear fan OK          Spinning at normal speed
    Top Right Front fan OK          Spinning at normal speed
    Top Left Rear fan  OK          Spinning at normal speed
    Bottom Left Front fan OK          Spinning at normal speed
    Bottom Right Rear fan OK          Spinning at normal speed
    Bottom Right Front fan OK          Spinning at normal speed
    Bottom Left Rear fan OK          Spinning at normal speed
    Rear Fan 1 (TOP)   OK          Spinning at normal speed
```

Rear Fan 2	OK	Spinning at normal speed
Rear Fan 3	OK	Spinning at normal speed
Rear Fan 4	OK	Spinning at normal speed
Rear Fan 5	OK	Spinning at normal speed
Rear Fan 6	OK	Spinning at normal speed
Rear Fan 7 (Bottom)	OK	Spinning at normal speed
Misc CIP	OK	

show chassis environment (MX150)

```
user@host> show chassis environment
```

Class	Item	Status	Measurement
Power	FPC 0 Power Supply 0	OK	
Temp	FPC 0 Sensor 1	OK	42 degrees C / 107 degrees F
	FPC 0 Sensor 2	OK	39 degrees C / 102 degrees F
	FPC 0 Coretemp	OK	75 degrees C / 167 degrees F
Fans	FPC 0 Fan Tray 0	OK	Spinning at normal speed
	FPC 0 Fan Tray 1	OK	Spinning at normal speed

show chassis environment (MX104 Router)

```
user@host> show chassis environment
```

Class	Item	Status	Measurement
Temp	PEM 0	OK	34 degrees C / 93 degrees F
	PEM 1	Absent	
ABB	0 Intake	OK	33 degrees C / 91 degrees F
	0 Exhaust A	OK	42 degrees C / 107 degrees F
	0 Exhaust B	OK	43 degrees C / 109 degrees F
	1 Intake	Absent	
	1 Exhaust A	Absent	
	1 Exhaust B	Absent	
Routing Engine 0		OK	34 degrees C / 93 degrees F
	CPU	OK	46 degrees C / 114 degrees F
Routing Engine 1		Absent	
	CPU	Absent	
AFEB 0	AFEB Processor	OK	33 degrees C / 91 degrees F
Fans	Fan 1	OK	Spinning at normal speed
	Fan 2	OK	Spinning at normal speed
	Fan 3	OK	Spinning at normal speed

Fan 4	OK	Spinning at normal speed
Fan 5	OK	Spinning at normal speed

show chassis environment (MX240 Router)

```

user@host> show chassis environment
Class Item                               Status      Measurement
Temp PEM 0                               OK          40 degrees C / 104 degrees F
      PEM 1                               OK          45 degrees C / 113 degrees F
      PEM 2                               Absent
      PEM 3                               Absent
Routing Engine 0                         OK          39 degrees C / 102 degrees F
Routing Engine 1                         OK          37 degrees C / 98 degrees F
CB 0 Intake                              OK          36 degrees C / 96 degrees F
CB 0 Exhaust A                           OK          34 degrees C / 93 degrees F
CB 0 Exhaust B                           OK          38 degrees C / 100 degrees F
CB 0 ACBC                                 OK          37 degrees C / 98 degrees F
CB 0 SF A                                 OK          49 degrees C / 120 degrees F
CB 0 SF B                                 OK          41 degrees C / 105 degrees F
CB 1 Intake                              OK          37 degrees C / 98 degrees F
CB 1 Exhaust A                           OK          34 degrees C / 93 degrees F
CB 1 Exhaust B                           OK          39 degrees C / 102 degrees F
CB 1 ACBC                                 OK          38 degrees C / 100 degrees F
CB 1 SF A                                 OK          47 degrees C / 116 degrees F
CB 1 SF B                                 OK          41 degrees C / 105 degrees F
FPC 1 Intake                             OK          33 degrees C / 91 degrees F
FPC 1 Exhaust A                          OK          38 degrees C / 100 degrees F
FPC 1 Exhaust B                          OK          53 degrees C / 127 degrees F
FPC 1 I3 0 TSensor                        OK          50 degrees C / 122 degrees F
FPC 1 I3 0 Chip                           OK          53 degrees C / 127 degrees F
FPC 1 I3 1 TSensor                        OK          49 degrees C / 120 degrees F
FPC 1 I3 1 Chip                           OK          52 degrees C / 125 degrees F
FPC 1 I3 2 TSensor                        OK          47 degrees C / 116 degrees F
FPC 1 I3 2 Chip                           OK          49 degrees C / 120 degrees F
FPC 1 I3 3 TSensor                        OK          44 degrees C / 111 degrees F
FPC 1 I3 3 Chip                           OK          46 degrees C / 114 degrees F
FPC 1 IA 0 TSensor                        OK          45 degrees C / 113 degrees F
FPC 1 IA 0 Chip                           OK          44 degrees C / 111 degrees F
FPC 1 IA 1 TSensor                        OK          44 degrees C / 111 degrees F
FPC 1 IA 1 Chip                           OK          48 degrees C / 118 degrees F
FPC 2 Intake                             OK          32 degrees C / 89 degrees F

```

	FPC 2 Exhaust A	OK	40 degrees C / 104 degrees F
	FPC 2 Exhaust B	OK	52 degrees C / 125 degrees F
	FPC 2 I3 0 TSensor	OK	52 degrees C / 125 degrees F
	FPC 2 I3 0 Chip	OK	56 degrees C / 132 degrees F
	FPC 2 I3 1 TSensor	OK	52 degrees C / 125 degrees F
	FPC 2 I3 1 Chip	OK	55 degrees C / 131 degrees F
	FPC 2 I3 2 TSensor	OK	49 degrees C / 120 degrees F
	FPC 2 I3 2 Chip	OK	52 degrees C / 125 degrees F
	FPC 2 I3 3 TSensor	OK	44 degrees C / 111 degrees F
	FPC 2 I3 3 Chip	OK	48 degrees C / 118 degrees F
	FPC 2 IA 0 TSensor	OK	50 degrees C / 122 degrees F
	FPC 2 IA 0 Chip	OK	48 degrees C / 118 degrees F
	FPC 2 IA 1 TSensor	OK	47 degrees C / 116 degrees F
	FPC 2 IA 1 Chip	OK	53 degrees C / 127 degrees F
Fans	Front Fan	OK	Spinning at normal speed
	Middle Fan	OK	Spinning at normal speed
	Rear Fan	OK	Spinning at normal speed

show chassis environment (MX240 Router with SCBE)

```

user@host> show chassis environment
Class Item                Status      Measurement
Temp PEM 0                 OK          40 degrees C / 104 degrees F
      PEM 1                 OK          45 degrees C / 113 degrees F
      PEM 2                 Absent
      PEM 3                 Absent
      Routing Engine 0     OK          39 degrees C / 102 degrees F
      Routing Engine 1     OK          37 degrees C / 98 degrees F
      CB 0 Intake          OK          36 degrees C / 96 degrees F
      CB 0 Exhaust A       OK          34 degrees C / 93 degrees F
      CB 0 Exhaust B       OK          38 degrees C / 100 degrees F
      CB 0 ACBC            OK          37 degrees C / 98 degrees F
      CB 0 XF A            OK          49 degrees C / 120 degrees F
      CB 0 XF B            OK          41 degrees C / 105 degrees F
      CB 1 Intake          OK          37 degrees C / 98 degrees F
      CB 1 Exhaust A       OK          34 degrees C / 93 degrees F
      CB 1 Exhaust B       OK          39 degrees C / 102 degrees F
      CB 1 ACBC            OK          38 degrees C / 100 degrees F
      CB 1 XF A            OK          47 degrees C / 116 degrees F
      CB 1 XF B            OK          41 degrees C / 105 degrees F
      FPC 1 Intake         OK          33 degrees C / 91 degrees F

```

FPC 1 Exhaust A	OK	38 degrees C / 100 degrees F
FPC 1 Exhaust B	OK	53 degrees C / 127 degrees F
FPC 1 I3 0 TSensor	OK	50 degrees C / 122 degrees F
FPC 1 I3 0 Chip	OK	53 degrees C / 127 degrees F
FPC 1 I3 1 TSensor	OK	49 degrees C / 120 degrees F
FPC 1 I3 1 Chip	OK	52 degrees C / 125 degrees F
FPC 1 I3 2 TSensor	OK	47 degrees C / 116 degrees F
FPC 1 I3 2 Chip	OK	49 degrees C / 120 degrees F
FPC 1 I3 3 TSensor	OK	44 degrees C / 111 degrees F
FPC 1 I3 3 Chip	OK	46 degrees C / 114 degrees F
FPC 1 IA 0 TSensor	OK	45 degrees C / 113 degrees F
FPC 1 IA 0 Chip	OK	44 degrees C / 111 degrees F
FPC 1 IA 1 TSensor	OK	44 degrees C / 111 degrees F
FPC 1 IA 1 Chip	OK	48 degrees C / 118 degrees F
FPC 2 Intake	OK	32 degrees C / 89 degrees F
FPC 2 Exhaust A	OK	40 degrees C / 104 degrees F
FPC 2 Exhaust B	OK	52 degrees C / 125 degrees F
FPC 2 I3 0 TSensor	OK	52 degrees C / 125 degrees F
FPC 2 I3 0 Chip	OK	56 degrees C / 132 degrees F
FPC 2 I3 1 TSensor	OK	52 degrees C / 125 degrees F
FPC 2 I3 1 Chip	OK	55 degrees C / 131 degrees F
FPC 2 I3 2 TSensor	OK	49 degrees C / 120 degrees F
FPC 2 I3 2 Chip	OK	52 degrees C / 125 degrees F
FPC 2 I3 3 TSensor	OK	44 degrees C / 111 degrees F
FPC 2 I3 3 Chip	OK	48 degrees C / 118 degrees F
FPC 2 IA 0 TSensor	OK	50 degrees C / 122 degrees F
FPC 2 IA 0 Chip	OK	48 degrees C / 118 degrees F
FPC 2 IA 1 TSensor	OK	47 degrees C / 116 degrees F
FPC 2 IA 1 Chip	OK	53 degrees C / 127 degrees F
Fans Front Fan	OK	Spinning at normal speed
Middle Fan	OK	Spinning at normal speed
Rear Fan	OK	Spinning at normal speed

show chassis environment (MX480 Router)

```

user@host> show chassis environment
Class Item                Status      Measurement
Temp  PEM 0                  OK          35 degrees C / 95 degrees F
      PEM 1                  OK          40 degrees C / 104 degrees F
      PEM 2                  Absent
      PEM 3                  Absent

```

Routing Engine 0	OK	44 degrees C / 111 degrees F
Routing Engine 1	OK	45 degrees C / 113 degrees F
CB 0 Intake	OK	36 degrees C / 96 degrees F
CB 0 Exhaust A	OK	38 degrees C / 100 degrees F
CB 0 Exhaust B	OK	39 degrees C / 102 degrees F
CB 0 ACBC	OK	37 degrees C / 98 degrees F
CB 0 SF A	OK	51 degrees C / 123 degrees F
CB 0 SF B	OK	44 degrees C / 111 degrees F
CB 1 Intake	OK	36 degrees C / 96 degrees F
CB 1 Exhaust A	OK	39 degrees C / 102 degrees F
CB 1 Exhaust B	OK	40 degrees C / 104 degrees F
CB 1 ACBC	OK	37 degrees C / 98 degrees F
CB 1 SF A	OK	50 degrees C / 122 degrees F
CB 1 SF B	OK	43 degrees C / 109 degrees F
FPC 0 Intake	OK	36 degrees C / 96 degrees F
FPC 0 Exhaust A	OK	39 degrees C / 102 degrees F
FPC 0 Exhaust B	OK	51 degrees C / 123 degrees F
FPC 0 I3 0 TSensor	OK	49 degrees C / 120 degrees F
FPC 0 I3 0 Chip	OK	56 degrees C / 132 degrees F
FPC 0 I3 1 TSensor	OK	47 degrees C / 116 degrees F
FPC 0 I3 1 Chip	OK	52 degrees C / 125 degrees F
FPC 0 I3 2 TSensor	OK	46 degrees C / 114 degrees F
FPC 0 I3 2 Chip	OK	48 degrees C / 118 degrees F
FPC 0 I3 3 TSensor	OK	42 degrees C / 107 degrees F
FPC 0 I3 3 Chip	OK	45 degrees C / 113 degrees F
FPC 0 IA 0 TSensor	OK	45 degrees C / 113 degrees F
FPC 0 IA 0 Chip	OK	45 degrees C / 113 degrees F
FPC 0 IA 1 TSensor	OK	44 degrees C / 111 degrees F
FPC 0 IA 1 Chip	OK	48 degrees C / 118 degrees F
FPC 1 Intake	OK	37 degrees C / 98 degrees F
FPC 1 Exhaust A	OK	41 degrees C / 105 degrees F
FPC 1 Exhaust B	OK	52 degrees C / 125 degrees F
FPC 1 I3 0 TSensor	OK	51 degrees C / 123 degrees F
FPC 1 I3 0 Chip	OK	57 degrees C / 134 degrees F
FPC 1 I3 1 TSensor	OK	48 degrees C / 118 degrees F
FPC 1 I3 1 Chip	OK	52 degrees C / 125 degrees F
FPC 1 I3 2 TSensor	OK	46 degrees C / 114 degrees F
FPC 1 I3 2 Chip	OK	50 degrees C / 122 degrees F
FPC 1 I3 3 TSensor	OK	42 degrees C / 107 degrees F
FPC 1 I3 3 Chip	OK	46 degrees C / 114 degrees F
FPC 1 IA 0 TSensor	OK	49 degrees C / 120 degrees F
FPC 1 IA 0 Chip	OK	48 degrees C / 118 degrees F
FPC 1 IA 1 TSensor	OK	46 degrees C / 114 degrees F

	FPC 1 IA 1 Chip	OK	50 degrees C / 122 degrees F
Fans	Top Rear Fan	OK	Spinning at normal speed
	Bottom Rear Fan	OK	Spinning at normal speed
	Top Middle Fan	OK	Spinning at normal speed
	Bottom Middle Fan	OK	Spinning at normal speed
	Top Front Fan	OK	Spinning at normal speed
	Bottom Front Fan	OK	Spinning at normal speed

show chassis environment (MX480 Router with SCBE)

```

user@host> show chassis environment
Class Item                               Status      Measurement
Temp PEM 0                               OK          35 degrees C / 95 degrees F
      PEM 1                               OK          40 degrees C / 104 degrees F
      PEM 2                               Absent
      PEM 3                               Absent
      Routing Engine 0                    OK          44 degrees C / 111 degrees F
      Routing Engine 1                    OK          45 degrees C / 113 degrees F
      CB 0 Intake                          OK          36 degrees C / 96 degrees F
      CB 0 Exhaust A                       OK          38 degrees C / 100 degrees F
      CB 0 Exhaust B                       OK          39 degrees C / 102 degrees F
      CB 0 ACBC                             OK          37 degrees C / 98 degrees F
      CB 0 XF A                             OK          51 degrees C / 123 degrees F
      CB 0 XF B                             OK          44 degrees C / 111 degrees F
      CB 1 Intake                          OK          36 degrees C / 96 degrees F
      CB 1 Exhaust A                       OK          39 degrees C / 102 degrees F
      CB 1 Exhaust B                       OK          40 degrees C / 104 degrees F
      CB 1 ACBC                             OK          37 degrees C / 98 degrees F
      CB 1 XF A                             OK          50 degrees C / 122 degrees F
      CB 1 XF B                             OK          43 degrees C / 109 degrees F
      FPC 0 Intake                          OK          36 degrees C / 96 degrees F
      FPC 0 Exhaust A                       OK          39 degrees C / 102 degrees F
      FPC 0 Exhaust B                       OK          51 degrees C / 123 degrees F
      FPC 0 I3 0 TSensor                    OK          49 degrees C / 120 degrees F
      FPC 0 I3 0 Chip                       OK          56 degrees C / 132 degrees F
      FPC 0 I3 1 TSensor                    OK          47 degrees C / 116 degrees F
      FPC 0 I3 1 Chip                       OK          52 degrees C / 125 degrees F
      FPC 0 I3 2 TSensor                    OK          46 degrees C / 114 degrees F
      FPC 0 I3 2 Chip                       OK          48 degrees C / 118 degrees F
      FPC 0 I3 3 TSensor                    OK          42 degrees C / 107 degrees F
      FPC 0 I3 3 Chip                       OK          45 degrees C / 113 degrees F

```

FPC 0 IA 0 TSensor	OK	45 degrees C / 113 degrees F
FPC 0 IA 0 Chip	OK	45 degrees C / 113 degrees F
FPC 0 IA 1 TSensor	OK	44 degrees C / 111 degrees F
FPC 0 IA 1 Chip	OK	48 degrees C / 118 degrees F
FPC 1 Intake	OK	37 degrees C / 98 degrees F
FPC 1 Exhaust A	OK	41 degrees C / 105 degrees F
FPC 1 Exhaust B	OK	52 degrees C / 125 degrees F
FPC 1 I3 0 TSensor	OK	51 degrees C / 123 degrees F
FPC 1 I3 0 Chip	OK	57 degrees C / 134 degrees F
FPC 1 I3 1 TSensor	OK	48 degrees C / 118 degrees F
FPC 1 I3 1 Chip	OK	52 degrees C / 125 degrees F
FPC 1 I3 2 TSensor	OK	46 degrees C / 114 degrees F
FPC 1 I3 2 Chip	OK	50 degrees C / 122 degrees F
FPC 1 I3 3 TSensor	OK	42 degrees C / 107 degrees F
FPC 1 I3 3 Chip	OK	46 degrees C / 114 degrees F
FPC 1 IA 0 TSensor	OK	49 degrees C / 120 degrees F
FPC 1 IA 0 Chip	OK	48 degrees C / 118 degrees F
FPC 1 IA 1 TSensor	OK	46 degrees C / 114 degrees F
FPC 1 IA 1 Chip	OK	50 degrees C / 122 degrees F
Fans Top Rear Fan	OK	Spinning at normal speed
Bottom Rear Fan	OK	Spinning at normal speed
Top Middle Fan	OK	Spinning at normal speed
Bottom Middle Fan	OK	Spinning at normal speed
Top Front Fan	OK	Spinning at normal speed
Bottom Front Fan	OK	Spinning at normal speed

show chassis environment (MX960 Router)

```

user@host> show chassis environment
Class Item                Status      Measurement
Temp PEM 0                Absent
    PEM 1                 Absent
    PEM 2                 Check
    PEM 3                 OK          35 degrees C / 95 degrees F
Routing Engine 0         OK          37 degrees C / 98 degrees F
Routing Engine 1         Absent
CB 0 Intake              OK          24 degrees C / 75 degrees F
CB 0 Exhaust A           OK          30 degrees C / 86 degrees F
CB 0 Exhaust B           OK          27 degrees C / 80 degrees F
CB 1 Intake              Absent
CB 1 Exhaust A           Absent

```

CB 1 Exhaust B	Absent	
CB 1 ACBC	Absent	
CB 1 SF A	Absent	
CB 1 SF B	Absent	
CB 2 Intake	Absent	
CB 2 Exhaust A	Absent	
CB 2 Exhaust B	Absent	
CB 2 ACBC	Absent	
CB 2 SF A	Absent	
CB 2 SF B	Absent	
FPC 4 Intake	OK	24 degrees C / 75 degrees F
FPC 4 Exhaust A	OK	36 degrees C / 96 degrees F
FPC 4 Exhaust B	OK	38 degrees C / 100 degrees F
FPC 7 Intake	OK	24 degrees C / 75 degrees F
FPC 7 Exhaust A	OK	36 degrees C / 96 degrees F
FPC 7 Exhaust B	OK	42 degrees C / 107 degrees F
Fans Top Fan Tray Temp	Failed	
Top Tray Fan 1	OK	Spinning at normal speed
Top Tray Fan 2	OK	Spinning at normal speed
Top Tray Fan 3	OK	Spinning at normal speed
Top Tray Fan 4	OK	Spinning at normal speed
Top Tray Fan 5	OK	Spinning at normal speed
Top Tray Fan 6	OK	Spinning at normal speed
Bottom Fan Tray Temp	Failed	
Bottom Tray Fan 1	OK	Spinning at normal speed
Bottom Tray Fan 2	OK	Spinning at normal speed
Bottom Tray Fan 3	OK	Spinning at normal speed
Bottom Tray Fan 4	OK	Spinning at normal speed
Bottom Tray Fan 5	OK	Spinning at normal speed
Bottom Tray Fan 6	OK	Spinning at normal speed

show chassis environment (MX960 Router with SCBE)

```

user@host> show chassis environment
Class Item                Status      Measurement
Temp PEM 0                Absent
    PEM 1                 OK         50 degrees C / 122 degrees F
    PEM 2                 OK         50 degrees C / 122 degrees F
    PEM 3                 OK         50 degrees C / 122 degrees F
Routing Engine 0         OK         42 degrees C / 107 degrees F
Routing Engine 0 CPU    OK         51 degrees C / 123 degrees F

```

Routing Engine 1	OK	39 degrees C / 102 degrees F
Routing Engine 1 CPU	OK	44 degrees C / 111 degrees F
CB 0 Intake	OK	35 degrees C / 95 degrees F
CB 0 Exhaust A	OK	36 degrees C / 96 degrees F
CB 0 Exhaust B	OK	43 degrees C / 109 degrees F
CB 0 ACBC	OK	38 degrees C / 100 degrees F
CB 0 XF A	OK	53 degrees C / 127 degrees F
CB 0 XF B	OK	47 degrees C / 116 degrees F
CB 1 Intake	OK	35 degrees C / 95 degrees F
CB 1 Exhaust A	OK	35 degrees C / 95 degrees F
CB 1 Exhaust B	OK	41 degrees C / 105 degrees F
CB 1 ACBC	OK	38 degrees C / 100 degrees F
CB 1 XF A	OK	52 degrees C / 125 degrees F
CB 1 XF B	OK	47 degrees C / 116 degrees F
CB 2 Intake	OK	32 degrees C / 89 degrees F
CB 2 Exhaust A	OK	30 degrees C / 86 degrees F
CB 2 Exhaust B	OK	35 degrees C / 95 degrees F
CB 2 ACBC	OK	33 degrees C / 91 degrees F
CB 2 XF A	OK	51 degrees C / 123 degrees F
CB 2 XF B	OK	50 degrees C / 122 degrees F
FPC 0 Intake	OK	35 degrees C / 95 degrees F
FPC 0 Exhaust A	OK	39 degrees C / 102 degrees F
FPC 0 Exhaust B	OK	50 degrees C / 122 degrees F
FPC 0 I3 0 TSensor	OK	50 degrees C / 122 degrees F
FPC 0 I3 0 Chip	OK	56 degrees C / 132 degrees F
FPC 0 I3 1 TSensor	OK	47 degrees C / 116 degrees F
FPC 0 I3 1 Chip	OK	50 degrees C / 122 degrees F
FPC 0 I3 2 TSensor	OK	45 degrees C / 113 degrees F
FPC 0 I3 2 Chip	OK	48 degrees C / 118 degrees F
FPC 0 I3 3 TSensor	OK	41 degrees C / 105 degrees F
FPC 0 I3 3 Chip	OK	44 degrees C / 111 degrees F
FPC 0 IA 0 TSensor	OK	45 degrees C / 113 degrees F
FPC 0 IA 0 Chip	OK	45 degrees C / 113 degrees F
FPC 0 IA 1 TSensor	OK	44 degrees C / 111 degrees F
FPC 0 IA 1 Chip	OK	48 degrees C / 118 degrees F
FPC 1 Intake	OK	36 degrees C / 96 degrees F
FPC 1 Exhaust A	OK	47 degrees C / 116 degrees F
FPC 1 Exhaust B	OK	43 degrees C / 109 degrees F
FPC 1 LU 0 TCAM TSensor	OK	53 degrees C / 127 degrees F
FPC 1 LU 0 TCAM Chip	OK	57 degrees C / 134 degrees F
FPC 1 LU 0 TSensor	OK	53 degrees C / 127 degrees F
FPC 1 LU 0 Chip	OK	60 degrees C / 140 degrees F
FPC 1 MQ 0 TSensor	OK	53 degrees C / 127 degrees F

FPC 1 MQ 0 Chip	OK	56 degrees C / 132 degrees F
FPC 1 LU 1 TCAM TSensor	OK	51 degrees C / 123 degrees F
FPC 1 LU 1 TCAM Chip	OK	52 degrees C / 125 degrees F
FPC 1 LU 1 TSensor	OK	51 degrees C / 123 degrees F
FPC 1 LU 1 Chip	OK	53 degrees C / 127 degrees F
FPC 1 MQ 1 TSensor	OK	51 degrees C / 123 degrees F
FPC 1 MQ 1 Chip	OK	58 degrees C / 136 degrees F
FPC 2 Intake	OK	35 degrees C / 95 degrees F
FPC 2 Exhaust A	OK	39 degrees C / 102 degrees F
FPC 2 Exhaust B	OK	54 degrees C / 129 degrees F
FPC 2 I3 0 TSensor	OK	52 degrees C / 125 degrees F
FPC 2 I3 0 Chip	OK	59 degrees C / 138 degrees F
FPC 2 I3 1 TSensor	OK	48 degrees C / 118 degrees F
FPC 2 I3 1 Chip	OK	52 degrees C / 125 degrees F
FPC 2 I3 2 TSensor	OK	47 degrees C / 116 degrees F
FPC 2 I3 2 Chip	OK	49 degrees C / 120 degrees F
FPC 2 I3 3 TSensor	OK	41 degrees C / 105 degrees F
FPC 2 I3 3 Chip	OK	44 degrees C / 111 degrees F
FPC 2 IA 0 TSensor	OK	47 degrees C / 116 degrees F
FPC 2 IA 0 Chip	OK	46 degrees C / 114 degrees F
FPC 2 IA 1 TSensor	OK	45 degrees C / 113 degrees F
FPC 2 IA 1 Chip	OK	49 degrees C / 120 degrees F
FPC 3 Intake	OK	34 degrees C / 93 degrees F
FPC 3 Exhaust A	OK	34 degrees C / 93 degrees F
FPC 3 Exhaust B	OK	47 degrees C / 116 degrees F
FPC 3 I3 0 TSensor	OK	48 degrees C / 118 degrees F
FPC 3 I3 0 Chip	OK	52 degrees C / 125 degrees F
FPC 3 I3 1 TSensor	OK	46 degrees C / 114 degrees F
FPC 3 I3 1 Chip	OK	48 degrees C / 118 degrees F
FPC 3 IA 0 TSensor	OK	41 degrees C / 105 degrees F
FPC 3 IA 0 Chip	OK	40 degrees C / 104 degrees F
FPC 5 Intake	OK	42 degrees C / 107 degrees F
FPC 5 Exhaust A	OK	42 degrees C / 107 degrees F
FPC 5 Exhaust B	OK	53 degrees C / 127 degrees F
FPC 5 LU 0 TSensor	OK	53 degrees C / 127 degrees F
FPC 5 LU 0 Chip	OK	54 degrees C / 129 degrees F
FPC 5 LU 1 TSensor	OK	53 degrees C / 127 degrees F
FPC 5 LU 1 Chip	OK	61 degrees C / 141 degrees F
FPC 5 LU 2 TSensor	OK	53 degrees C / 127 degrees F
FPC 5 LU 2 Chip	OK	51 degrees C / 123 degrees F
FPC 5 LU 3 TSensor	OK	53 degrees C / 127 degrees F
FPC 5 LU 3 Chip	OK	53 degrees C / 127 degrees F
FPC 5 MQ 0 TSensor	OK	47 degrees C / 116 degrees F

FPC 5 MQ 0 Chip	OK	52 degrees C / 125 degrees F
FPC 5 MQ 1 TSensor	OK	47 degrees C / 116 degrees F
FPC 5 MQ 1 Chip	OK	52 degrees C / 125 degrees F
FPC 5 MQ 2 TSensor	OK	47 degrees C / 116 degrees F
FPC 5 MQ 2 Chip	OK	46 degrees C / 114 degrees F
FPC 5 MQ 3 TSensor	OK	47 degrees C / 116 degrees F
FPC 5 MQ 3 Chip	OK	45 degrees C / 113 degrees F
FPC 7 Intake	OK	36 degrees C / 96 degrees F
FPC 7 Exhaust A	OK	35 degrees C / 95 degrees F
FPC 7 Exhaust B	OK	33 degrees C / 91 degrees F
FPC 7 QX 0 TSensor	OK	42 degrees C / 107 degrees F
FPC 7 QX 0 Chip	OK	47 degrees C / 116 degrees F
FPC 7 LU 0 TCAM TSensor	OK	42 degrees C / 107 degrees F
FPC 7 LU 0 TCAM Chip	OK	44 degrees C / 111 degrees F
FPC 7 LU 0 TSensor	OK	42 degrees C / 107 degrees F
FPC 7 LU 0 Chip	OK	46 degrees C / 114 degrees F
FPC 7 MQ 0 TSensor	OK	42 degrees C / 107 degrees F
FPC 7 MQ 0 Chip	OK	45 degrees C / 113 degrees F
FPC 8 Intake	OK	33 degrees C / 91 degrees F
FPC 8 Exhaust A	OK	33 degrees C / 91 degrees F
FPC 8 Exhaust B	OK	36 degrees C / 96 degrees F
FPC 8 I3 0 TSensor	OK	38 degrees C / 100 degrees F
FPC 8 I3 0 Chip	OK	43 degrees C / 109 degrees F
FPC 8 BDS 0 TSensor	OK	37 degrees C / 98 degrees F
FPC 8 BDS 0 Chip	OK	36 degrees C / 96 degrees F
FPC 8 IA 0 TSensor	OK	37 degrees C / 98 degrees F
FPC 8 IA 0 Chip	OK	37 degrees C / 98 degrees F
FPC 10 Intake	OK	38 degrees C / 100 degrees F
FPC 10 Exhaust A	OK	36 degrees C / 96 degrees F
FPC 10 Exhaust B	OK	41 degrees C / 105 degrees F
FPC 10 I3 0 TSensor	OK	40 degrees C / 104 degrees F
FPC 10 I3 0 Chip	OK	42 degrees C / 107 degrees F
FPC 10 I3 1 TSensor	OK	40 degrees C / 104 degrees F
FPC 10 I3 1 Chip	OK	44 degrees C / 111 degrees F
FPC 10 I3 2 TSensor	OK	42 degrees C / 107 degrees F
FPC 10 I3 2 Chip	OK	43 degrees C / 109 degrees F
FPC 10 I3 3 TSensor	OK	39 degrees C / 102 degrees F
FPC 10 I3 3 Chip	OK	44 degrees C / 111 degrees F
FPC 10 IA 0 TSensor	OK	36 degrees C / 96 degrees F
FPC 10 IA 0 Chip	OK	36 degrees C / 96 degrees F
FPC 10 IA 1 TSensor	OK	43 degrees C / 109 degrees F
FPC 10 IA 1 Chip	OK	42 degrees C / 107 degrees F
Fans Top Fan Tray Temp	OK	37 degrees C / 98 degrees F

Top Tray Fan 1	OK	Spinning at normal speed
Top Tray Fan 2	OK	Spinning at normal speed
Top Tray Fan 3	OK	Spinning at normal speed
Top Tray Fan 4	OK	Spinning at normal speed
Top Tray Fan 5	OK	Spinning at normal speed
Top Tray Fan 6	OK	Spinning at normal speed
Bottom Fan Tray Temp	OK	28 degrees C / 82 degrees F
Bottom Tray Fan 1	OK	Spinning at normal speed
Bottom Tray Fan 2	OK	Spinning at normal speed
Bottom Tray Fan 3	OK	Spinning at normal speed
Bottom Tray Fan 4	OK	Spinning at normal speed
Bottom Tray Fan 5	OK	Spinning at normal speed
Bottom Tray Fan 6	OK	Spinning at normal speed

show chassis environment (MX960 Router with MPC5EQ)

```

user@host> show chassis environment
Class Item                Status      Measurement
Temp PEM 0                OK         50 degrees C / 122 degrees F
      PEM 1                OK         45 degrees C / 113 degrees F
      PEM 2                OK         45 degrees C / 113 degrees F
      PEM 3                Absent
      Routing Engine 0     OK         31 degrees C / 87 degrees F
      Routing Engine 0 CPU OK         30 degrees C / 86 degrees F
      Routing Engine 1     Present
      Routing Engine 1 CPU Present
      CB 0 Intake          OK         29 degrees C / 84 degrees F
      CB 0 Exhaust A       OK         29 degrees C / 84 degrees F
      CB 0 Exhaust B       OK         34 degrees C / 93 degrees F
      CB 0 ACBC            OK         32 degrees C / 89 degrees F
      CB 0 XF A            OK         49 degrees C / 120 degrees F
      CB 0 XF B            OK         45 degrees C / 113 degrees F
      CB 1 Intake          OK         26 degrees C / 78 degrees F
      CB 1 Exhaust A       OK         26 degrees C / 78 degrees F
      CB 1 Exhaust B       OK         27 degrees C / 80 degrees F
      CB 1 ACBC            OK         26 degrees C / 78 degrees F
      CB 1 XF A            OK         32 degrees C / 89 degrees F
      CB 1 XF B            OK         32 degrees C / 89 degrees F
      CB 2 Intake          OK         28 degrees C / 82 degrees F
      CB 2 Exhaust A       OK         27 degrees C / 80 degrees F
      CB 2 Exhaust B       OK         33 degrees C / 91 degrees F

```

CB 2 ACBC	OK	30 degrees C / 86 degrees F
CB 2 XF A	OK	48 degrees C / 118 degrees F
CB 2 XF B	OK	46 degrees C / 114 degrees F
FPC 0 Intake	OK	38 degrees C / 100 degrees F
FPC 0 Exhaust A	OK	48 degrees C / 118 degrees F
FPC 0 Exhaust B	OK	49 degrees C / 120 degrees F
FPC 0 XL TSen	OK	48 degrees C / 118 degrees F
FPC 0 XL Chip	OK	50 degrees C / 122 degrees F
FPC 0 XL_XR0 TSen	OK	48 degrees C / 118 degrees F
FPC 0 XL_XR0 Chip	OK	53 degrees C / 127 degrees F
FPC 0 XL_XR1 TSen	OK	48 degrees C / 118 degrees F
FPC 0 XL_XR1 Chip	OK	54 degrees C / 129 degrees F
FPC 0 XQ TSen	OK	48 degrees C / 118 degrees F
FPC 0 XQ Chip	OK	52 degrees C / 125 degrees F
FPC 0 XQ_XR0 TSen	OK	48 degrees C / 118 degrees F
FPC 0 XQ_XR0 Chip	OK	62 degrees C / 143 degrees F
FPC 0 XQ_XR1 TSen	OK	48 degrees C / 118 degrees F
FPC 0 XQ_XR1 Chip	OK	62 degrees C / 143 degrees F
FPC 0 XM 0 TSen	OK	53 degrees C / 127 degrees F
FPC 0 XM 0 Chip	OK	63 degrees C / 145 degrees F
FPC 0 XM 1 TSen	OK	53 degrees C / 127 degrees F
FPC 0 XM 1 Chip	OK	46 degrees C / 114 degrees F
FPC 0 PLX PCIe Switch TSe	OK	53 degrees C / 127 degrees F
FPC 0 PLX PCIe Switch Chi	OK	66 degrees C / 150 degrees F
FPC 1 Intake	OK	31 degrees C / 87 degrees F
FPC 1 Exhaust A	OK	38 degrees C / 100 degrees F
FPC 1 Exhaust B	OK	49 degrees C / 120 degrees F
FPC 1 LU 0 TSen	OK	41 degrees C / 105 degrees F
FPC 1 LU 0 Chip	OK	47 degrees C / 116 degrees F
FPC 1 LU 1 TSen	OK	41 degrees C / 105 degrees F
FPC 1 LU 1 Chip	OK	42 degrees C / 107 degrees F
FPC 1 LU 2 TSen	OK	41 degrees C / 105 degrees F
FPC 1 LU 2 Chip	OK	46 degrees C / 114 degrees F
FPC 1 LU 3 TSen	OK	41 degrees C / 105 degrees F
FPC 1 LU 3 Chip	OK	51 degrees C / 123 degrees F
FPC 1 XM 0 TSen	OK	41 degrees C / 105 degrees F
FPC 1 XM 0 Chip	OK	49 degrees C / 120 degrees F
FPC 1 XF 0 TSen	OK	41 degrees C / 105 degrees F
FPC 1 XF 0 Chip	OK	63 degrees C / 145 degrees F
FPC 1 PLX Switch TSen	OK	41 degrees C / 105 degrees F
FPC 1 PLX Switch Chip	OK	43 degrees C / 109 degrees F
FPC 3 Intake	OK	31 degrees C / 87 degrees F
FPC 3 Exhaust A	OK	37 degrees C / 98 degrees F

FPC 3 Exhaust B	OK	43 degrees C / 109 degrees F
FPC 3 LU 0 TSen	OK	42 degrees C / 107 degrees F
FPC 3 LU 0 Chip	OK	43 degrees C / 109 degrees F
FPC 3 LU 1 TSen	OK	42 degrees C / 107 degrees F
FPC 3 LU 1 Chip	OK	46 degrees C / 114 degrees F
FPC 3 LU 2 TSen	OK	42 degrees C / 107 degrees F
FPC 3 LU 2 Chip	OK	40 degrees C / 104 degrees F
FPC 3 LU 3 TSen	OK	42 degrees C / 107 degrees F
FPC 3 LU 3 Chip	OK	41 degrees C / 105 degrees F
FPC 3 MQ 0 TSen	OK	37 degrees C / 98 degrees F
FPC 3 MQ 0 Chip	OK	37 degrees C / 98 degrees F
FPC 3 MQ 1 TSen	OK	37 degrees C / 98 degrees F
FPC 3 MQ 1 Chip	OK	40 degrees C / 104 degrees F
FPC 3 MQ 2 TSen	OK	37 degrees C / 98 degrees F
FPC 3 MQ 2 Chip	OK	36 degrees C / 96 degrees F
FPC 3 MQ 3 TSen	OK	37 degrees C / 98 degrees F
FPC 3 MQ 3 Chip	OK	38 degrees C / 100 degrees F
FPC 4 Intake	OK	34 degrees C / 93 degrees F
FPC 4 Exhaust A	OK	45 degrees C / 113 degrees F
FPC 4 Exhaust B	OK	47 degrees C / 116 degrees F
FPC 4 XL TSen	OK	44 degrees C / 111 degrees F
FPC 4 XL Chip	OK	47 degrees C / 116 degrees F
FPC 4 XL_XR0 TSen	OK	44 degrees C / 111 degrees F
FPC 4 XL_XR0 Chip	OK	48 degrees C / 118 degrees F
FPC 4 XL_XR1 TSen	OK	44 degrees C / 111 degrees F
FPC 4 XL_XR1 Chip	OK	47 degrees C / 116 degrees F
FPC 4 XQ TSen	OK	44 degrees C / 111 degrees F
FPC 4 XQ Chip	OK	47 degrees C / 116 degrees F
FPC 4 XQ_XR0 TSen	OK	44 degrees C / 111 degrees F
FPC 4 XQ_XR0 Chip	OK	57 degrees C / 134 degrees F
FPC 4 XQ_XR1 TSen	OK	44 degrees C / 111 degrees F
FPC 4 XQ_XR1 Chip	OK	58 degrees C / 136 degrees F
FPC 4 XM 0 TSen	OK	51 degrees C / 123 degrees F
FPC 4 XM 0 Chip	OK	61 degrees C / 141 degrees F
FPC 4 XM 1 TSen	OK	51 degrees C / 123 degrees F
FPC 4 XM 1 Chip	OK	47 degrees C / 116 degrees F
FPC 4 PLX PCIe Switch TSe	OK	51 degrees C / 123 degrees F
FPC 4 PLX PCIe Switch Chi	OK	60 degrees C / 140 degrees F
FPC 5 Intake	OK	34 degrees C / 93 degrees F
FPC 5 Exhaust A	OK	45 degrees C / 113 degrees F
FPC 5 Exhaust B	OK	47 degrees C / 116 degrees F
FPC 5 XL TSen	OK	45 degrees C / 113 degrees F
FPC 5 XL Chip	OK	47 degrees C / 116 degrees F

FPC 5 XL_XR0 TSen	OK	45 degrees C / 113 degrees F
FPC 5 XL_XR0 Chip	OK	49 degrees C / 120 degrees F
FPC 5 XL_XR1 TSen	OK	45 degrees C / 113 degrees F
FPC 5 XL_XR1 Chip	OK	49 degrees C / 120 degrees F
FPC 5 XQ TSen	OK	45 degrees C / 113 degrees F
FPC 5 XQ Chip	OK	48 degrees C / 118 degrees F
FPC 5 XQ_XR0 TSen	OK	45 degrees C / 113 degrees F
FPC 5 XQ_XR0 Chip	OK	60 degrees C / 140 degrees F
FPC 5 XQ_XR1 TSen	OK	45 degrees C / 113 degrees F
FPC 5 XQ_XR1 Chip	OK	58 degrees C / 136 degrees F
FPC 5 XM 0 TSen	OK	50 degrees C / 122 degrees F
FPC 5 XM 0 Chip	OK	48 degrees C / 118 degrees F
FPC 5 XM 1 TSen	OK	50 degrees C / 122 degrees F
FPC 5 XM 1 Chip	OK	47 degrees C / 116 degrees F
FPC 5 PLX PCIe Switch TSe	OK	50 degrees C / 122 degrees F
FPC 5 PLX PCIe Switch Chi	OK	59 degrees C / 138 degrees F
FPC 7 Intake	OK	32 degrees C / 89 degrees F
FPC 7 Exhaust A	OK	32 degrees C / 89 degrees F
FPC 7 Exhaust B	OK	33 degrees C / 91 degrees F
FPC 7 LU 0 TSen	OK	49 degrees C / 120 degrees F
FPC 7 LU 0 Chip	OK	44 degrees C / 111 degrees F
FPC 7 LU 1 TSen	OK	49 degrees C / 120 degrees F
FPC 7 LU 1 Chip	OK	47 degrees C / 116 degrees F
FPC 7 LU 2 TSen	OK	49 degrees C / 120 degrees F
FPC 7 LU 2 Chip	OK	39 degrees C / 102 degrees F
FPC 7 LU 3 TSen	OK	49 degrees C / 120 degrees F
FPC 7 LU 3 Chip	OK	43 degrees C / 109 degrees F
FPC 7 XM 0 TSen	OK	49 degrees C / 120 degrees F
FPC 7 XM 0 Chip	OK	57 degrees C / 134 degrees F
FPC 7 XM 1 TSen	OK	49 degrees C / 120 degrees F
FPC 7 XM 1 Chip	OK	48 degrees C / 118 degrees F
FPC 7 PLX Switch TSen	OK	49 degrees C / 120 degrees F
FPC 7 PLX Switch Chip	OK	45 degrees C / 113 degrees F
FPC 8 Intake	OK	36 degrees C / 96 degrees F
FPC 8 Exhaust A	OK	51 degrees C / 123 degrees F
FPC 8 Exhaust B	OK	46 degrees C / 114 degrees F
FPC 8 XL TSen	OK	46 degrees C / 114 degrees F
FPC 8 XL Chip	OK	47 degrees C / 116 degrees F
FPC 8 XL_XR0 TSen	OK	46 degrees C / 114 degrees F
FPC 8 XL_XR0 Chip	OK	53 degrees C / 127 degrees F
FPC 8 XL_XR1 TSen	OK	46 degrees C / 114 degrees F
FPC 8 XL_XR1 Chip	OK	52 degrees C / 125 degrees F
FPC 8 XQ TSen	OK	46 degrees C / 114 degrees F

FPC 8 XQ Chip	OK	46 degrees C / 114 degrees F
FPC 8 XQ_XR0 TSen	OK	46 degrees C / 114 degrees F
FPC 8 XQ_XR0 Chip	OK	59 degrees C / 138 degrees F
FPC 8 XQ_XR1 TSen	OK	46 degrees C / 114 degrees F
FPC 8 XQ_XR1 Chip	OK	57 degrees C / 134 degrees F
FPC 8 XM 0 TSen	OK	52 degrees C / 125 degrees F
FPC 8 XM 0 Chip	OK	61 degrees C / 141 degrees F
FPC 8 XM 1 TSen	OK	52 degrees C / 125 degrees F
FPC 8 XM 1 Chip	OK	47 degrees C / 116 degrees F
FPC 8 PLX PCIe Switch TSe	OK	52 degrees C / 125 degrees F
FPC 8 PLX PCIe Switch Chi	OK	63 degrees C / 145 degrees F
FPC 9 Intake	OK	31 degrees C / 87 degrees F
FPC 9 Exhaust A	OK	34 degrees C / 93 degrees F
FPC 9 Exhaust B	OK	35 degrees C / 95 degrees F
FPC 9 QX 0 TSen	OK	42 degrees C / 107 degrees F
FPC 9 QX 0 Chip	OK	45 degrees C / 113 degrees F
FPC 9 LU 0 TCAM TSen	OK	42 degrees C / 107 degrees F
FPC 9 LU 0 TCAM Chip	OK	41 degrees C / 105 degrees F
FPC 9 LU 0 TSen	OK	42 degrees C / 107 degrees F
FPC 9 LU 0 Chip	OK	43 degrees C / 109 degrees F
FPC 9 MQ 0 TSen	OK	42 degrees C / 107 degrees F
FPC 9 MQ 0 Chip	OK	43 degrees C / 109 degrees F
FPC 9 QX 1 TSen	OK	38 degrees C / 100 degrees F
FPC 9 QX 1 Chip	OK	40 degrees C / 104 degrees F
FPC 9 LU 1 TCAM TSen	OK	38 degrees C / 100 degrees F
FPC 9 LU 1 TCAM Chip	OK	38 degrees C / 100 degrees F
FPC 9 LU 1 TSen	OK	38 degrees C / 100 degrees F
FPC 9 LU 1 Chip	OK	41 degrees C / 105 degrees F
FPC 9 MQ 1 TSen	OK	38 degrees C / 100 degrees F
FPC 9 MQ 1 Chip	OK	41 degrees C / 105 degrees F
FPC 10 Intake	OK	35 degrees C / 95 degrees F
FPC 10 Exhaust A	OK	51 degrees C / 123 degrees F
FPC 10 Exhaust B	OK	46 degrees C / 114 degrees F
FPC 10 XL TSen	OK	42 degrees C / 107 degrees F
FPC 10 XL Chip	OK	44 degrees C / 111 degrees F
FPC 10 XL_XR0 TSen	OK	42 degrees C / 107 degrees F
FPC 10 XL_XR0 Chip	OK	47 degrees C / 116 degrees F
FPC 10 XL_XR1 TSen	OK	42 degrees C / 107 degrees F
FPC 10 XL_XR1 Chip	OK	48 degrees C / 118 degrees F
FPC 10 XQ TSen	OK	42 degrees C / 107 degrees F
FPC 10 XQ Chip	OK	46 degrees C / 114 degrees F
FPC 10 XQ_XR0 TSen	OK	42 degrees C / 107 degrees F
FPC 10 XQ_XR0 Chip	OK	57 degrees C / 134 degrees F

FPC 10 XQ_XR1 TSen	OK	42 degrees C / 107 degrees F
FPC 10 XQ_XR1 Chip	OK	53 degrees C / 127 degrees F
FPC 10 XM 0 TSen	OK	51 degrees C / 123 degrees F
FPC 10 XM 0 Chip	OK	61 degrees C / 141 degrees F
FPC 10 XM 1 TSen	OK	51 degrees C / 123 degrees F
FPC 10 XM 1 Chip	OK	49 degrees C / 120 degrees F
FPC 10 PLX PCIe Switch TSe	OK	51 degrees C / 123 degrees F
FPC 10 PLX PCIe Switch Chi	OK	61 degrees C / 141 degrees F
FPC 11 Intake	OK	33 degrees C / 91 degrees F
FPC 11 Exhaust A	OK	33 degrees C / 91 degrees F
FPC 11 Exhaust B	OK	34 degrees C / 93 degrees F
FPC 11 LU 0 TSen	OK	50 degrees C / 122 degrees F
FPC 11 LU 0 Chip	OK	48 degrees C / 118 degrees F
FPC 11 LU 1 TSen	OK	50 degrees C / 122 degrees F
FPC 11 LU 1 Chip	OK	50 degrees C / 122 degrees F
FPC 11 LU 2 TSen	OK	50 degrees C / 122 degrees F
FPC 11 LU 2 Chip	OK	41 degrees C / 105 degrees F
FPC 11 LU 3 TSen	OK	50 degrees C / 122 degrees F
FPC 11 LU 3 Chip	OK	48 degrees C / 118 degrees F
FPC 11 XM 0 TSen	OK	50 degrees C / 122 degrees F
FPC 11 XM 0 Chip	OK	57 degrees C / 134 degrees F
FPC 11 XM 1 TSen	OK	50 degrees C / 122 degrees F
FPC 11 XM 1 Chip	OK	52 degrees C / 125 degrees F
FPC 11 PLX Switch TSen	OK	50 degrees C / 122 degrees F
FPC 11 PLX Switch Chip	OK	45 degrees C / 113 degrees F
Fans Top Fan Tray Temp	OK	42 degrees C / 107 degrees F
Top Tray Fan 1	OK	Spinning at high speed
Top Tray Fan 2	OK	Spinning at high speed
Top Tray Fan 3	OK	Spinning at high speed
Top Tray Fan 4	OK	Spinning at high speed
Top Tray Fan 5	OK	Spinning at high speed
Top Tray Fan 6	OK	Spinning at high speed
Top Tray Fan 7	OK	Spinning at high speed
Top Tray Fan 8	OK	Spinning at high speed
Top Tray Fan 9	OK	Spinning at high speed
Top Tray Fan 10	OK	Spinning at high speed
Top Tray Fan 11	OK	Spinning at high speed
Top Tray Fan 12	OK	Spinning at high speed
Bottom Fan Tray Temp	OK	33 degrees C / 91 degrees F
Bottom Tray Fan 1	OK	Spinning at high speed
Bottom Tray Fan 2	OK	Spinning at high speed
Bottom Tray Fan 3	OK	Spinning at high speed
Bottom Tray Fan 4	OK	Spinning at high speed

Bottom Tray Fan 5	OK	Spinning at high speed
Bottom Tray Fan 6	OK	Spinning at high speed
Bottom Tray Fan 7	OK	Spinning at high speed
Bottom Tray Fan 8	OK	Spinning at high speed
Bottom Tray Fan 9	OK	Spinning at high speed
Bottom Tray Fan 10	OK	Spinning at high speed
Bottom Tray Fan 11	OK	Spinning at high speed
Bottom Tray Fan 12	OK	Spinning at high speed

show chassis environment (MX2020 Router)

```

user@host> show chassis environment
Class Item                Status      Measurement
Temp PSM 0                 Absent
      PSM 1                 Absent
      PSM 2                 OK          41 degrees C / 105 degrees F
      PSM 3                 OK          39 degrees C / 102 degrees F
      PSM 4                 OK          39 degrees C / 102 degrees F
      PSM 5                 OK          38 degrees C / 100 degrees F
      PSM 6                 OK          38 degrees C / 100 degrees F
      PSM 7                 OK          38 degrees C / 100 degrees F
      PSM 8                 OK          37 degrees C / 98 degrees F
      PSM 9                 Absent
      PSM 10                Absent
      PSM 11                OK          47 degrees C / 116 degrees F
      PSM 12                OK          45 degrees C / 113 degrees F
      PSM 13                OK          44 degrees C / 111 degrees F
      PSM 14                OK          44 degrees C / 111 degrees F
      PSM 15                OK          43 degrees C / 109 degrees F
      PSM 16                OK          42 degrees C / 107 degrees F
      PSM 17                OK          41 degrees C / 105 degrees F
      PDM 0                 OK
      PDM 1                 Absent
      PDM 2                 Absent
      PDM 3                 OK
      CB 0 IntakeA-Zone0    OK          45 degrees C / 113 degrees F
      CB 0 IntakeB-Zone1    OK          34 degrees C / 93 degrees F
      CB 0 IntakeC-Zone0    OK          48 degrees C / 118 degrees F
      CB 0 ExhaustA-Zone0   OK          45 degrees C / 113 degrees F
      CB 0 ExhaustB-Zone1   OK          37 degrees C / 98 degrees F
      CB 0 TCBC-Zone0       OK          41 degrees C / 105 degrees F

```

CB 1 IntakeA-Zone0	OK	46 degrees C / 114 degrees F
CB 1 IntakeB-Zone1	OK	42 degrees C / 107 degrees F
CB 1 IntakeC-Zone0	OK	49 degrees C / 120 degrees F
CB 1 ExhaustA-Zone0	OK	46 degrees C / 114 degrees F
CB 1 ExhaustB-Zone1	OK	41 degrees C / 105 degrees F
CB 1 TCBC-Zone0	OK	46 degrees C / 114 degrees F
SPMB 0 Intake	OK	33 degrees C / 91 degrees F
SPMB 1 Intake	OK	42 degrees C / 107 degrees F
Routing Engine 0	OK	35 degrees C / 95 degrees F
Routing Engine 0 CPU	OK	34 degrees C / 93 degrees F
Routing Engine 1	OK	44 degrees C / 111 degrees F
Routing Engine 1 CPU	OK	42 degrees C / 107 degrees F
SFB 0 Intake-Zone0	OK	55 degrees C / 131 degrees F
SFB 0 Exhaust-Zone1	OK	48 degrees C / 118 degrees F
SFB 0 IntakeA-Zone0	OK	50 degrees C / 122 degrees F
SFB 0 IntakeB-Zone1	OK	40 degrees C / 104 degrees F
SFB 0 Exhaust-Zone0	OK	52 degrees C / 125 degrees F
SFB 0 SFB-XF2-Zone1	OK	61 degrees C / 141 degrees F
SFB 0 SFB-XF1-Zone0	OK	69 degrees C / 156 degrees F
SFB 0 SFB-XF0-Zone0	OK	68 degrees C / 154 degrees F
SFB 1 Intake-Zone0	OK	56 degrees C / 132 degrees F
SFB 1 Exhaust-Zone1	OK	47 degrees C / 116 degrees F
SFB 1 IntakeA-Zone0	OK	51 degrees C / 123 degrees F
SFB 1 IntakeB-Zone1	OK	40 degrees C / 104 degrees F
SFB 1 Exhaust-Zone0	OK	51 degrees C / 123 degrees F
SFB 1 SFB-XF2-Zone1	OK	62 degrees C / 143 degrees F
SFB 1 SFB-XF1-Zone0	OK	67 degrees C / 152 degrees F
SFB 1 SFB-XF0-Zone0	OK	69 degrees C / 156 degrees F
SFB 2 Intake-Zone0	OK	56 degrees C / 132 degrees F
SFB 2 Exhaust-Zone1	OK	47 degrees C / 116 degrees F
SFB 2 IntakeA-Zone0	OK	51 degrees C / 123 degrees F
SFB 2 IntakeB-Zone1	OK	40 degrees C / 104 degrees F
SFB 2 Exhaust-Zone0	OK	53 degrees C / 127 degrees F
SFB 2 SFB-XF2-Zone1	OK	65 degrees C / 149 degrees F
SFB 2 SFB-XF1-Zone0	OK	69 degrees C / 156 degrees F
SFB 2 SFB-XF0-Zone0	OK	70 degrees C / 158 degrees F
SFB 3 Intake-Zone0	OK	57 degrees C / 134 degrees F
SFB 3 Exhaust-Zone1	OK	48 degrees C / 118 degrees F
SFB 3 IntakeA-Zone0	OK	52 degrees C / 125 degrees F
SFB 3 IntakeB-Zone1	OK	41 degrees C / 105 degrees F
SFB 3 Exhaust-Zone0	OK	53 degrees C / 127 degrees F
SFB 3 SFB-XF2-Zone1	OK	66 degrees C / 150 degrees F
SFB 3 SFB-XF1-Zone0	OK	69 degrees C / 156 degrees F

SFB 3 SFB-XF0-Zone0	OK	71 degrees C / 159 degrees F
SFB 4 Intake-Zone0	OK	58 degrees C / 136 degrees F
SFB 4 Exhaust-Zone1	OK	49 degrees C / 120 degrees F
SFB 4 IntakeA-Zone0	OK	54 degrees C / 129 degrees F
SFB 4 IntakeB-Zone1	OK	42 degrees C / 107 degrees F
SFB 4 Exhaust-Zone0	OK	53 degrees C / 127 degrees F
SFB 4 SFB-XF2-Zone1	OK	64 degrees C / 147 degrees F
SFB 4 SFB-XF1-Zone0	OK	68 degrees C / 154 degrees F
SFB 4 SFB-XF0-Zone0	OK	71 degrees C / 159 degrees F
SFB 5 Intake-Zone0	OK	58 degrees C / 136 degrees F
SFB 5 Exhaust-Zone1	OK	50 degrees C / 122 degrees F
SFB 5 IntakeA-Zone0	OK	53 degrees C / 127 degrees F
SFB 5 IntakeB-Zone1	OK	43 degrees C / 109 degrees F
SFB 5 Exhaust-Zone0	OK	54 degrees C / 129 degrees F
SFB 5 SFB-XF2-Zone1	OK	66 degrees C / 150 degrees F
SFB 5 SFB-XF1-Zone0	OK	69 degrees C / 156 degrees F
SFB 5 SFB-XF0-Zone0	OK	74 degrees C / 165 degrees F
SFB 6 Intake-Zone0	OK	58 degrees C / 136 degrees F
SFB 6 Exhaust-Zone1	OK	49 degrees C / 120 degrees F
SFB 6 IntakeA-Zone0	OK	53 degrees C / 127 degrees F
SFB 6 IntakeB-Zone1	OK	43 degrees C / 109 degrees F
SFB 6 Exhaust-Zone0	OK	53 degrees C / 127 degrees F
SFB 6 SFB-XF2-Zone1	OK	65 degrees C / 149 degrees F
SFB 6 SFB-XF1-Zone0	OK	68 degrees C / 154 degrees F
SFB 6 SFB-XF0-Zone0	OK	72 degrees C / 161 degrees F
SFB 7 Intake-Zone0	OK	57 degrees C / 134 degrees F
SFB 7 Exhaust-Zone1	OK	50 degrees C / 122 degrees F
SFB 7 IntakeA-Zone0	OK	53 degrees C / 127 degrees F
SFB 7 IntakeB-Zone1	OK	43 degrees C / 109 degrees F
SFB 7 Exhaust-Zone0	OK	54 degrees C / 129 degrees F
SFB 7 SFB-XF2-Zone1	OK	68 degrees C / 154 degrees F
SFB 7 SFB-XF1-Zone0	OK	69 degrees C / 156 degrees F
SFB 7 SFB-XF0-Zone0	OK	73 degrees C / 163 degrees F
FPC 0 Intake	OK	41 degrees C / 105 degrees F
FPC 0 Exhaust A	OK	48 degrees C / 118 degrees F
FPC 0 Exhaust B	OK	62 degrees C / 143 degrees F
FPC 0 LU 0 TSen	OK	59 degrees C / 138 degrees F
FPC 0 LU 0 Chip	OK	62 degrees C / 143 degrees F
FPC 0 LU 1 TSen	OK	59 degrees C / 138 degrees F
FPC 0 LU 1 Chip	OK	64 degrees C / 147 degrees F
FPC 0 LU 2 TSen	OK	59 degrees C / 138 degrees F
FPC 0 LU 2 Chip	OK	53 degrees C / 127 degrees F
FPC 0 LU 3 TSen	OK	59 degrees C / 138 degrees F

FPC 0 LU 3 Chip	OK	53 degrees C / 127 degrees F
FPC 0 MQ 0 TSen	OK	47 degrees C / 116 degrees F
FPC 0 MQ 0 Chip	OK	49 degrees C / 120 degrees F
FPC 0 MQ 1 TSen	OK	47 degrees C / 116 degrees F
FPC 0 MQ 1 Chip	OK	51 degrees C / 123 degrees F
FPC 0 MQ 2 TSen	OK	47 degrees C / 116 degrees F
FPC 0 MQ 2 Chip	OK	44 degrees C / 111 degrees F
FPC 0 MQ 3 TSen	OK	47 degrees C / 116 degrees F
FPC 0 MQ 3 Chip	OK	45 degrees C / 113 degrees F
FPC 1 Intake	OK	40 degrees C / 104 degrees F
FPC 1 Exhaust A	OK	49 degrees C / 120 degrees F
FPC 1 Exhaust B	OK	58 degrees C / 136 degrees F
FPC 1 LU 0 TSen	OK	55 degrees C / 131 degrees F
FPC 1 LU 0 Chip	OK	56 degrees C / 132 degrees F
FPC 1 LU 1 TSen	OK	55 degrees C / 131 degrees F
FPC 1 LU 1 Chip	OK	58 degrees C / 136 degrees F
FPC 1 LU 2 TSen	OK	55 degrees C / 131 degrees F
FPC 1 LU 2 Chip	OK	49 degrees C / 120 degrees F
FPC 1 LU 3 TSen	OK	55 degrees C / 131 degrees F
FPC 1 LU 3 Chip	OK	51 degrees C / 123 degrees F
FPC 1 MQ 0 TSen	OK	47 degrees C / 116 degrees F
FPC 1 MQ 0 Chip	OK	48 degrees C / 118 degrees F
FPC 1 MQ 1 TSen	OK	47 degrees C / 116 degrees F
FPC 1 MQ 1 Chip	OK	50 degrees C / 122 degrees F
FPC 1 MQ 2 TSen	OK	47 degrees C / 116 degrees F
FPC 1 MQ 2 Chip	OK	44 degrees C / 111 degrees F
FPC 1 MQ 3 TSen	OK	47 degrees C / 116 degrees F
FPC 1 MQ 3 Chip	OK	44 degrees C / 111 degrees F
FPC 2 Intake	OK	39 degrees C / 102 degrees F
FPC 2 Exhaust A	OK	49 degrees C / 120 degrees F
FPC 2 Exhaust B	OK	61 degrees C / 141 degrees F
FPC 2 LU 0 TSen	OK	58 degrees C / 136 degrees F
FPC 2 LU 0 Chip	OK	60 degrees C / 140 degrees F
FPC 2 LU 1 TSen	OK	58 degrees C / 136 degrees F
FPC 2 LU 1 Chip	OK	65 degrees C / 149 degrees F
FPC 2 LU 2 TSen	OK	58 degrees C / 136 degrees F
FPC 2 LU 2 Chip	OK	51 degrees C / 123 degrees F
FPC 2 LU 3 TSen	OK	58 degrees C / 136 degrees F
FPC 2 LU 3 Chip	OK	53 degrees C / 127 degrees F
FPC 2 MQ 0 TSen	OK	47 degrees C / 116 degrees F
FPC 2 MQ 0 Chip	OK	50 degrees C / 122 degrees F
FPC 2 MQ 1 TSen	OK	47 degrees C / 116 degrees F
FPC 2 MQ 1 Chip	OK	52 degrees C / 125 degrees F

FPC 2 MQ 2 TSen	OK	47 degrees C / 116 degrees F
FPC 2 MQ 2 Chip	OK	45 degrees C / 113 degrees F
FPC 2 MQ 3 TSen	OK	47 degrees C / 116 degrees F
FPC 2 MQ 3 Chip	OK	46 degrees C / 114 degrees F
FPC 3 Intake	OK	40 degrees C / 104 degrees F
FPC 3 Exhaust A	OK	49 degrees C / 120 degrees F
FPC 3 Exhaust B	OK	61 degrees C / 141 degrees F
FPC 3 LU 0 TSen	OK	58 degrees C / 136 degrees F
FPC 3 LU 0 Chip	OK	61 degrees C / 141 degrees F
FPC 3 LU 1 TSen	OK	58 degrees C / 136 degrees F
FPC 3 LU 1 Chip	OK	62 degrees C / 143 degrees F
FPC 3 LU 2 TSen	OK	58 degrees C / 136 degrees F
FPC 3 LU 2 Chip	OK	51 degrees C / 123 degrees F
FPC 3 LU 3 TSen	OK	58 degrees C / 136 degrees F
FPC 3 LU 3 Chip	OK	53 degrees C / 127 degrees F
FPC 3 MQ 0 TSen	OK	48 degrees C / 118 degrees F
FPC 3 MQ 0 Chip	OK	50 degrees C / 122 degrees F
FPC 3 MQ 1 TSen	OK	48 degrees C / 118 degrees F
FPC 3 MQ 1 Chip	OK	54 degrees C / 129 degrees F
FPC 3 MQ 2 TSen	OK	48 degrees C / 118 degrees F
FPC 3 MQ 2 Chip	OK	45 degrees C / 113 degrees F
FPC 3 MQ 3 TSen	OK	48 degrees C / 118 degrees F
FPC 3 MQ 3 Chip	OK	48 degrees C / 118 degrees F
FPC 4 Intake	OK	40 degrees C / 104 degrees F
FPC 4 Exhaust A	OK	49 degrees C / 120 degrees F
FPC 4 Exhaust B	OK	62 degrees C / 143 degrees F
FPC 4 LU 0 TSen	OK	59 degrees C / 138 degrees F
FPC 4 LU 0 Chip	OK	62 degrees C / 143 degrees F
FPC 4 LU 1 TSen	OK	59 degrees C / 138 degrees F
FPC 4 LU 1 Chip	OK	65 degrees C / 149 degrees F
FPC 4 LU 2 TSen	OK	59 degrees C / 138 degrees F
FPC 4 LU 2 Chip	OK	51 degrees C / 123 degrees F
FPC 4 LU 3 TSen	OK	59 degrees C / 138 degrees F
FPC 4 LU 3 Chip	OK	53 degrees C / 127 degrees F
FPC 4 MQ 0 TSen	OK	48 degrees C / 118 degrees F
FPC 4 MQ 0 Chip	OK	52 degrees C / 125 degrees F
FPC 4 MQ 1 TSen	OK	48 degrees C / 118 degrees F
FPC 4 MQ 1 Chip	OK	53 degrees C / 127 degrees F
FPC 4 MQ 2 TSen	OK	48 degrees C / 118 degrees F
FPC 4 MQ 2 Chip	OK	46 degrees C / 114 degrees F
FPC 4 MQ 3 TSen	OK	48 degrees C / 118 degrees F
FPC 4 MQ 3 Chip	OK	47 degrees C / 116 degrees F
FPC 5 Intake	OK	41 degrees C / 105 degrees F

FPC 5 Exhaust A	OK	50 degrees C / 122 degrees F
FPC 5 Exhaust B	OK	63 degrees C / 145 degrees F
FPC 5 LU 0 TSen	OK	60 degrees C / 140 degrees F
FPC 5 LU 0 Chip	OK	63 degrees C / 145 degrees F
FPC 5 LU 1 TSen	OK	60 degrees C / 140 degrees F
FPC 5 LU 1 Chip	OK	66 degrees C / 150 degrees F
FPC 5 LU 2 TSen	OK	60 degrees C / 140 degrees F
FPC 5 LU 2 Chip	OK	56 degrees C / 132 degrees F
FPC 5 LU 3 TSen	OK	60 degrees C / 140 degrees F
FPC 5 LU 3 Chip	OK	54 degrees C / 129 degrees F
FPC 5 MQ 0 TSen	OK	49 degrees C / 120 degrees F
FPC 5 MQ 0 Chip	OK	52 degrees C / 125 degrees F
FPC 5 MQ 1 TSen	OK	49 degrees C / 120 degrees F
FPC 5 MQ 1 Chip	OK	53 degrees C / 127 degrees F
FPC 5 MQ 2 TSen	OK	49 degrees C / 120 degrees F
FPC 5 MQ 2 Chip	OK	48 degrees C / 118 degrees F
FPC 5 MQ 3 TSen	OK	49 degrees C / 120 degrees F
FPC 5 MQ 3 Chip	OK	47 degrees C / 116 degrees F
FPC 6 Intake	OK	42 degrees C / 107 degrees F
FPC 6 Exhaust A	OK	51 degrees C / 123 degrees F
FPC 6 Exhaust B	OK	63 degrees C / 145 degrees F
FPC 6 LU 0 TSen	OK	61 degrees C / 141 degrees F
FPC 6 LU 0 Chip	OK	64 degrees C / 147 degrees F
FPC 6 LU 1 TSen	OK	61 degrees C / 141 degrees F
FPC 6 LU 1 Chip	OK	66 degrees C / 150 degrees F
FPC 6 LU 2 TSen	OK	61 degrees C / 141 degrees F
FPC 6 LU 2 Chip	OK	56 degrees C / 132 degrees F
FPC 6 LU 3 TSen	OK	61 degrees C / 141 degrees F
FPC 6 LU 3 Chip	OK	56 degrees C / 132 degrees F
FPC 6 MQ 0 TSen	OK	50 degrees C / 122 degrees F
FPC 6 MQ 0 Chip	OK	56 degrees C / 132 degrees F
FPC 6 MQ 1 TSen	OK	50 degrees C / 122 degrees F
FPC 6 MQ 1 Chip	OK	59 degrees C / 138 degrees F
FPC 6 MQ 2 TSen	OK	50 degrees C / 122 degrees F
FPC 6 MQ 2 Chip	OK	49 degrees C / 120 degrees F
FPC 6 MQ 3 TSen	OK	50 degrees C / 122 degrees F
FPC 6 MQ 3 Chip	OK	49 degrees C / 120 degrees F
FPC 7 Intake	OK	41 degrees C / 105 degrees F
FPC 7 Exhaust A	OK	51 degrees C / 123 degrees F
FPC 7 Exhaust B	OK	63 degrees C / 145 degrees F
FPC 7 LU 0 TSen	OK	60 degrees C / 140 degrees F
FPC 7 LU 0 Chip	OK	61 degrees C / 141 degrees F
FPC 7 LU 1 TSen	OK	60 degrees C / 140 degrees F

FPC 7 LU 1 Chip	OK	65 degrees C / 149 degrees F
FPC 7 LU 2 TSen	OK	60 degrees C / 140 degrees F
FPC 7 LU 2 Chip	OK	54 degrees C / 129 degrees F
FPC 7 LU 3 TSen	OK	60 degrees C / 140 degrees F
FPC 7 LU 3 Chip	OK	53 degrees C / 127 degrees F
FPC 7 MQ 0 TSen	OK	50 degrees C / 122 degrees F
FPC 7 MQ 0 Chip	OK	53 degrees C / 127 degrees F
FPC 7 MQ 1 TSen	OK	50 degrees C / 122 degrees F
FPC 7 MQ 1 Chip	OK	54 degrees C / 129 degrees F
FPC 7 MQ 2 TSen	OK	50 degrees C / 122 degrees F
FPC 7 MQ 2 Chip	OK	47 degrees C / 116 degrees F
FPC 7 MQ 3 TSen	OK	50 degrees C / 122 degrees F
FPC 7 MQ 3 Chip	OK	47 degrees C / 116 degrees F
FPC 8 Intake	OK	41 degrees C / 105 degrees F
FPC 8 Exhaust A	OK	50 degrees C / 122 degrees F
FPC 8 Exhaust B	OK	62 degrees C / 143 degrees F
FPC 8 LU 0 TSen	OK	59 degrees C / 138 degrees F
FPC 8 LU 0 Chip	OK	62 degrees C / 143 degrees F
FPC 8 LU 1 TSen	OK	59 degrees C / 138 degrees F
FPC 8 LU 1 Chip	OK	64 degrees C / 147 degrees F
FPC 8 LU 2 TSen	OK	59 degrees C / 138 degrees F
FPC 8 LU 2 Chip	OK	55 degrees C / 131 degrees F
FPC 8 LU 3 TSen	OK	59 degrees C / 138 degrees F
FPC 8 LU 3 Chip	OK	54 degrees C / 129 degrees F
FPC 8 MQ 0 TSen	OK	49 degrees C / 120 degrees F
FPC 8 MQ 0 Chip	OK	51 degrees C / 123 degrees F
FPC 8 MQ 1 TSen	OK	49 degrees C / 120 degrees F
FPC 8 MQ 1 Chip	OK	52 degrees C / 125 degrees F
FPC 8 MQ 2 TSen	OK	49 degrees C / 120 degrees F
FPC 8 MQ 2 Chip	OK	46 degrees C / 114 degrees F
FPC 8 MQ 3 TSen	OK	49 degrees C / 120 degrees F
FPC 8 MQ 3 Chip	OK	47 degrees C / 116 degrees F
FPC 9 Intake	OK	42 degrees C / 107 degrees F
FPC 9 Exhaust A	OK	51 degrees C / 123 degrees F
FPC 9 Exhaust B	OK	63 degrees C / 145 degrees F
FPC 9 LU 0 TSen	OK	60 degrees C / 140 degrees F
FPC 9 LU 0 Chip	OK	65 degrees C / 149 degrees F
FPC 9 LU 1 TSen	OK	60 degrees C / 140 degrees F
FPC 9 LU 1 Chip	OK	67 degrees C / 152 degrees F
FPC 9 LU 2 TSen	OK	60 degrees C / 140 degrees F
FPC 9 LU 2 Chip	OK	54 degrees C / 129 degrees F
FPC 9 LU 3 TSen	OK	60 degrees C / 140 degrees F
FPC 9 LU 3 Chip	OK	54 degrees C / 129 degrees F

FPC 9 MQ 0 TSen	OK	51 degrees C / 123 degrees F
FPC 9 MQ 0 Chip	OK	55 degrees C / 131 degrees F
FPC 9 MQ 1 TSen	OK	51 degrees C / 123 degrees F
FPC 9 MQ 1 Chip	OK	59 degrees C / 138 degrees F
FPC 9 MQ 2 TSen	OK	51 degrees C / 123 degrees F
FPC 9 MQ 2 Chip	OK	49 degrees C / 120 degrees F
FPC 9 MQ 3 TSen	OK	51 degrees C / 123 degrees F
FPC 9 MQ 3 Chip	OK	49 degrees C / 120 degrees F
FPC 10 Intake	OK	44 degrees C / 111 degrees F
FPC 10 Exhaust A	OK	49 degrees C / 120 degrees F
FPC 10 Exhaust B	OK	55 degrees C / 131 degrees F
FPC 10 LU 0 TSen	OK	54 degrees C / 129 degrees F
FPC 10 LU 0 Chip	OK	55 degrees C / 131 degrees F
FPC 10 LU 1 TSen	OK	54 degrees C / 129 degrees F
FPC 10 LU 1 Chip	OK	59 degrees C / 138 degrees F
FPC 10 LU 2 TSen	OK	54 degrees C / 129 degrees F
FPC 10 LU 2 Chip	OK	52 degrees C / 125 degrees F
FPC 10 LU 3 TSen	OK	54 degrees C / 129 degrees F
FPC 10 LU 3 Chip	OK	51 degrees C / 123 degrees F
FPC 10 MQ 0 TSen	OK	48 degrees C / 118 degrees F
FPC 10 MQ 0 Chip	OK	49 degrees C / 120 degrees F
FPC 10 MQ 1 TSen	OK	48 degrees C / 118 degrees F
FPC 10 MQ 1 Chip	OK	52 degrees C / 125 degrees F
FPC 10 MQ 2 TSen	OK	48 degrees C / 118 degrees F
FPC 10 MQ 2 Chip	OK	47 degrees C / 116 degrees F
FPC 10 MQ 3 TSen	OK	48 degrees C / 118 degrees F
FPC 10 MQ 3 Chip	OK	47 degrees C / 116 degrees F
FPC 11 Intake	OK	30 degrees C / 86 degrees F
FPC 11 Exhaust A	OK	35 degrees C / 95 degrees F
FPC 11 Exhaust B	OK	30 degrees C / 86 degrees F
FPC 11 LU 0 TSen	OK	57 degrees C / 134 degrees F
FPC 11 LU 0 Chip	OK	58 degrees C / 136 degrees F
FPC 11 LU 1 TSen	OK	57 degrees C / 134 degrees F
FPC 11 LU 1 Chip	OK	62 degrees C / 143 degrees F
FPC 11 LU 2 TSen	OK	57 degrees C / 134 degrees F
FPC 11 LU 2 Chip	OK	53 degrees C / 127 degrees F
FPC 11 LU 3 TSen	OK	57 degrees C / 134 degrees F
FPC 11 LU 3 Chip	OK	54 degrees C / 129 degrees F
FPC 11 MQ 0 TSen	OK	52 degrees C / 125 degrees F
FPC 11 MQ 0 Chip	OK	52 degrees C / 125 degrees F
FPC 11 MQ 1 TSen	OK	52 degrees C / 125 degrees F
FPC 11 MQ 1 Chip	OK	57 degrees C / 134 degrees F
FPC 11 MQ 2 TSen	OK	52 degrees C / 125 degrees F

FPC 11 MQ 2 Chip	OK	48 degrees C / 118 degrees F
FPC 11 MQ 3 TSen	OK	52 degrees C / 125 degrees F
FPC 11 MQ 3 Chip	OK	52 degrees C / 125 degrees F
FPC 12 Intake	OK	40 degrees C / 104 degrees F
FPC 12 Exhaust A	OK	47 degrees C / 116 degrees F
FPC 12 Exhaust B	OK	52 degrees C / 125 degrees F
FPC 12 LU 0 TSen	OK	51 degrees C / 123 degrees F
FPC 12 LU 0 Chip	OK	52 degrees C / 125 degrees F
FPC 12 LU 1 TSen	OK	51 degrees C / 123 degrees F
FPC 12 LU 1 Chip	OK	55 degrees C / 131 degrees F
FPC 12 LU 2 TSen	OK	51 degrees C / 123 degrees F
FPC 12 LU 2 Chip	OK	47 degrees C / 116 degrees F
FPC 12 LU 3 TSen	OK	51 degrees C / 123 degrees F
FPC 12 LU 3 Chip	OK	50 degrees C / 122 degrees F
FPC 12 MQ 0 TSen	OK	46 degrees C / 114 degrees F
FPC 12 MQ 0 Chip	OK	46 degrees C / 114 degrees F
FPC 12 MQ 1 TSen	OK	46 degrees C / 114 degrees F
FPC 12 MQ 1 Chip	OK	50 degrees C / 122 degrees F
FPC 12 MQ 2 TSen	OK	46 degrees C / 114 degrees F
FPC 12 MQ 2 Chip	OK	44 degrees C / 111 degrees F
FPC 12 MQ 3 TSen	OK	46 degrees C / 114 degrees F
FPC 12 MQ 3 Chip	OK	46 degrees C / 114 degrees F
FPC 13 Intake	OK	40 degrees C / 104 degrees F
FPC 13 Exhaust A	OK	48 degrees C / 118 degrees F
FPC 13 Exhaust B	OK	52 degrees C / 125 degrees F
FPC 13 LU 0 TSen	OK	51 degrees C / 123 degrees F
FPC 13 LU 0 Chip	OK	52 degrees C / 125 degrees F
FPC 13 LU 1 TSen	OK	51 degrees C / 123 degrees F
FPC 13 LU 1 Chip	OK	55 degrees C / 131 degrees F
FPC 13 LU 2 TSen	OK	51 degrees C / 123 degrees F
FPC 13 LU 2 Chip	OK	48 degrees C / 118 degrees F
FPC 13 LU 3 TSen	OK	51 degrees C / 123 degrees F
FPC 13 LU 3 Chip	OK	48 degrees C / 118 degrees F
FPC 13 MQ 0 TSen	OK	46 degrees C / 114 degrees F
FPC 13 MQ 0 Chip	OK	46 degrees C / 114 degrees F
FPC 13 MQ 1 TSen	OK	46 degrees C / 114 degrees F
FPC 13 MQ 1 Chip	OK	50 degrees C / 122 degrees F
FPC 13 MQ 2 TSen	OK	46 degrees C / 114 degrees F
FPC 13 MQ 2 Chip	OK	44 degrees C / 111 degrees F
FPC 13 MQ 3 TSen	OK	46 degrees C / 114 degrees F
FPC 13 MQ 3 Chip	OK	46 degrees C / 114 degrees F
FPC 14 Intake	OK	40 degrees C / 104 degrees F
FPC 14 Exhaust A	OK	50 degrees C / 122 degrees F

FPC 14 Exhaust B	OK	51 degrees C / 123 degrees F
FPC 14 LU 0 TSen	OK	50 degrees C / 122 degrees F
FPC 14 LU 0 Chip	OK	50 degrees C / 122 degrees F
FPC 14 LU 1 TSen	OK	50 degrees C / 122 degrees F
FPC 14 LU 1 Chip	OK	54 degrees C / 129 degrees F
FPC 14 LU 2 TSen	OK	50 degrees C / 122 degrees F
FPC 14 LU 2 Chip	OK	47 degrees C / 116 degrees F
FPC 14 LU 3 TSen	OK	50 degrees C / 122 degrees F
FPC 14 LU 3 Chip	OK	49 degrees C / 120 degrees F
FPC 14 MQ 0 TSen	OK	47 degrees C / 116 degrees F
FPC 14 MQ 0 Chip	OK	46 degrees C / 114 degrees F
FPC 14 MQ 1 TSen	OK	47 degrees C / 116 degrees F
FPC 14 MQ 1 Chip	OK	51 degrees C / 123 degrees F
FPC 14 MQ 2 TSen	OK	47 degrees C / 116 degrees F
FPC 14 MQ 2 Chip	OK	45 degrees C / 113 degrees F
FPC 14 MQ 3 TSen	OK	47 degrees C / 116 degrees F
FPC 14 MQ 3 Chip	OK	48 degrees C / 118 degrees F
FPC 15 Intake	OK	44 degrees C / 111 degrees F
FPC 15 Exhaust A	OK	49 degrees C / 120 degrees F
FPC 15 Exhaust B	OK	60 degrees C / 140 degrees F
FPC 15 LU 0 TSen	OK	50 degrees C / 122 degrees F
FPC 15 LU 0 Chip	OK	56 degrees C / 132 degrees F
FPC 15 LU 1 TSen	OK	50 degrees C / 122 degrees F
FPC 15 LU 1 Chip	OK	50 degrees C / 122 degrees F
FPC 15 LU 2 TSen	OK	50 degrees C / 122 degrees F
FPC 15 LU 2 Chip	OK	58 degrees C / 136 degrees F
FPC 15 LU 3 TSen	OK	50 degrees C / 122 degrees F
FPC 15 LU 3 Chip	OK	63 degrees C / 145 degrees F
FPC 15 XM 0 TSen	OK	50 degrees C / 122 degrees F
FPC 15 XM 0 Chip	OK	56 degrees C / 132 degrees F
FPC 15 XF 0 TSen	OK	50 degrees C / 122 degrees F
FPC 15 XF 0 Chip	OK	68 degrees C / 154 degrees F
FPC 15 PLX Switch TSen	OK	50 degrees C / 122 degrees F
FPC 15 PLX Switch Chip	OK	56 degrees C / 132 degrees F
FPC 16 Intake	OK	42 degrees C / 107 degrees F
FPC 16 Exhaust A	OK	51 degrees C / 123 degrees F
FPC 16 Exhaust B	OK	53 degrees C / 127 degrees F
FPC 16 LU 0 TSen	OK	51 degrees C / 123 degrees F
FPC 16 LU 0 Chip	OK	52 degrees C / 125 degrees F
FPC 16 LU 1 TSen	OK	51 degrees C / 123 degrees F
FPC 16 LU 1 Chip	OK	55 degrees C / 131 degrees F
FPC 16 LU 2 TSen	OK	51 degrees C / 123 degrees F
FPC 16 LU 2 Chip	OK	48 degrees C / 118 degrees F

FPC 16 LU 3 TSen	OK	51 degrees C / 123 degrees F
FPC 16 LU 3 Chip	OK	49 degrees C / 120 degrees F
FPC 16 MQ 0 TSen	OK	49 degrees C / 120 degrees F
FPC 16 MQ 0 Chip	OK	48 degrees C / 118 degrees F
FPC 16 MQ 1 TSen	OK	49 degrees C / 120 degrees F
FPC 16 MQ 1 Chip	OK	53 degrees C / 127 degrees F
FPC 16 MQ 2 TSen	OK	49 degrees C / 120 degrees F
FPC 16 MQ 2 Chip	OK	46 degrees C / 114 degrees F
FPC 16 MQ 3 TSen	OK	49 degrees C / 120 degrees F
FPC 16 MQ 3 Chip	OK	49 degrees C / 120 degrees F
FPC 17 Intake	OK	43 degrees C / 109 degrees F
FPC 17 Exhaust A	OK	51 degrees C / 123 degrees F
FPC 17 Exhaust B	OK	55 degrees C / 131 degrees F
FPC 17 LU 0 TSen	OK	54 degrees C / 129 degrees F
FPC 17 LU 0 Chip	OK	57 degrees C / 134 degrees F
FPC 17 LU 1 TSen	OK	54 degrees C / 129 degrees F
FPC 17 LU 1 Chip	OK	60 degrees C / 140 degrees F
FPC 17 LU 2 TSen	OK	54 degrees C / 129 degrees F
FPC 17 LU 2 Chip	OK	53 degrees C / 127 degrees F
FPC 17 LU 3 TSen	OK	54 degrees C / 129 degrees F
FPC 17 LU 3 Chip	OK	53 degrees C / 127 degrees F
FPC 17 MQ 0 TSen	OK	49 degrees C / 120 degrees F
FPC 17 MQ 0 Chip	OK	50 degrees C / 122 degrees F
FPC 17 MQ 1 TSen	OK	49 degrees C / 120 degrees F
FPC 17 MQ 1 Chip	OK	54 degrees C / 129 degrees F
FPC 17 MQ 2 TSen	OK	49 degrees C / 120 degrees F
FPC 17 MQ 2 Chip	OK	47 degrees C / 116 degrees F
FPC 17 MQ 3 TSen	OK	49 degrees C / 120 degrees F
FPC 17 MQ 3 Chip	OK	51 degrees C / 123 degrees F
FPC 18 Intake	OK	44 degrees C / 111 degrees F
FPC 18 Exhaust A	OK	53 degrees C / 127 degrees F
FPC 18 Exhaust B	OK	57 degrees C / 134 degrees F
FPC 18 LU 0 TSen	OK	56 degrees C / 132 degrees F
FPC 18 LU 0 Chip	OK	57 degrees C / 134 degrees F
FPC 18 LU 1 TSen	OK	56 degrees C / 132 degrees F
FPC 18 LU 1 Chip	OK	62 degrees C / 143 degrees F
FPC 18 LU 2 TSen	OK	56 degrees C / 132 degrees F
FPC 18 LU 2 Chip	OK	53 degrees C / 127 degrees F
FPC 18 LU 3 TSen	OK	56 degrees C / 132 degrees F
FPC 18 LU 3 Chip	OK	55 degrees C / 131 degrees F
FPC 18 MQ 0 TSen	OK	51 degrees C / 123 degrees F
FPC 18 MQ 0 Chip	OK	54 degrees C / 129 degrees F
FPC 18 MQ 1 TSen	OK	51 degrees C / 123 degrees F

FPC 18 MQ 1 Chip	OK	58 degrees C / 136 degrees F
FPC 18 MQ 2 TSen	OK	51 degrees C / 123 degrees F
FPC 18 MQ 2 Chip	OK	50 degrees C / 122 degrees F
FPC 18 MQ 3 TSen	OK	51 degrees C / 123 degrees F
FPC 18 MQ 3 Chip	OK	53 degrees C / 127 degrees F
FPC 19 Intake	OK	48 degrees C / 118 degrees F
FPC 19 Exhaust A	OK	56 degrees C / 132 degrees F
FPC 19 Exhaust B	OK	64 degrees C / 147 degrees F
FPC 19 LU 0 TSen	OK	63 degrees C / 145 degrees F
FPC 19 LU 0 Chip	OK	64 degrees C / 147 degrees F
FPC 19 LU 1 TSen	OK	63 degrees C / 145 degrees F
FPC 19 LU 1 Chip	OK	70 degrees C / 158 degrees F
FPC 19 LU 2 TSen	OK	63 degrees C / 145 degrees F
FPC 19 LU 2 Chip	OK	61 degrees C / 141 degrees F
FPC 19 LU 3 TSen	OK	63 degrees C / 145 degrees F
FPC 19 LU 3 Chip	OK	62 degrees C / 143 degrees F
FPC 19 MQ 0 TSen	OK	56 degrees C / 132 degrees F
FPC 19 MQ 0 Chip	OK	60 degrees C / 140 degrees F
FPC 19 MQ 1 TSen	OK	56 degrees C / 132 degrees F
FPC 19 MQ 1 Chip	OK	62 degrees C / 143 degrees F
FPC 19 MQ 2 TSen	OK	56 degrees C / 132 degrees F
FPC 19 MQ 2 Chip	OK	56 degrees C / 132 degrees F
FPC 19 MQ 3 TSen	OK	56 degrees C / 132 degrees F
FPC 19 MQ 3 Chip	OK	57 degrees C / 134 degrees F
ADC 0 Intake	OK	40 degrees C / 104 degrees F
ADC 0 Exhaust	OK	52 degrees C / 125 degrees F
ADC 0 ADC-XF1	OK	59 degrees C / 138 degrees F
ADC 0 ADC-XF0	OK	66 degrees C / 150 degrees F
ADC 1 Intake	OK	38 degrees C / 100 degrees F
ADC 1 Exhaust	OK	50 degrees C / 122 degrees F
ADC 1 ADC-XF1	OK	59 degrees C / 138 degrees F
ADC 1 ADC-XF0	OK	63 degrees C / 145 degrees F
ADC 2 Intake	OK	37 degrees C / 98 degrees F
ADC 2 Exhaust	OK	52 degrees C / 125 degrees F
ADC 2 ADC-XF1	OK	53 degrees C / 127 degrees F
ADC 2 ADC-XF0	OK	61 degrees C / 141 degrees F
ADC 3 Intake	OK	40 degrees C / 104 degrees F
ADC 3 Exhaust	OK	51 degrees C / 123 degrees F
ADC 3 ADC-XF1	OK	61 degrees C / 141 degrees F
ADC 3 ADC-XF0	OK	64 degrees C / 147 degrees F
ADC 4 Intake	OK	39 degrees C / 102 degrees F
ADC 4 Exhaust	OK	51 degrees C / 123 degrees F
ADC 4 ADC-XF1	OK	60 degrees C / 140 degrees F

ADC 4 ADC-XF0	OK	63 degrees C / 145 degrees F
ADC 5 Intake	OK	38 degrees C / 100 degrees F
ADC 5 Exhaust	OK	54 degrees C / 129 degrees F
ADC 5 ADC-XF1	OK	56 degrees C / 132 degrees F
ADC 5 ADC-XF0	OK	67 degrees C / 152 degrees F
ADC 6 Intake	OK	39 degrees C / 102 degrees F
ADC 6 Exhaust	OK	52 degrees C / 125 degrees F
ADC 6 ADC-XF1	OK	59 degrees C / 138 degrees F
ADC 6 ADC-XF0	OK	66 degrees C / 150 degrees F
ADC 7 Intake	OK	39 degrees C / 102 degrees F
ADC 7 Exhaust	OK	54 degrees C / 129 degrees F
ADC 7 ADC-XF1	OK	62 degrees C / 143 degrees F
ADC 7 ADC-XF0	OK	70 degrees C / 158 degrees F
ADC 8 Intake	OK	39 degrees C / 102 degrees F
ADC 8 Exhaust	OK	52 degrees C / 125 degrees F
ADC 8 ADC-XF1	OK	61 degrees C / 141 degrees F
ADC 8 ADC-XF0	OK	65 degrees C / 149 degrees F
ADC 9 Intake	OK	41 degrees C / 105 degrees F
ADC 9 Exhaust	OK	51 degrees C / 123 degrees F
ADC 9 ADC-XF1	OK	63 degrees C / 145 degrees F
ADC 9 ADC-XF0	OK	63 degrees C / 145 degrees F
ADC 10 Intake	OK	48 degrees C / 118 degrees F
ADC 10 Exhaust	OK	53 degrees C / 127 degrees F
ADC 10 ADC-XF1	OK	67 degrees C / 152 degrees F
ADC 10 ADC-XF0	OK	66 degrees C / 150 degrees F
ADC 12 Intake	OK	49 degrees C / 120 degrees F
ADC 12 Exhaust	OK	54 degrees C / 129 degrees F
ADC 12 ADC-XF1	OK	67 degrees C / 152 degrees F
ADC 12 ADC-XF0	OK	67 degrees C / 152 degrees F
ADC 13 Intake	OK	49 degrees C / 120 degrees F
ADC 13 Exhaust	OK	57 degrees C / 134 degrees F
ADC 13 ADC-XF1	OK	66 degrees C / 150 degrees F
ADC 13 ADC-XF0	OK	69 degrees C / 156 degrees F
ADC 14 Intake	OK	51 degrees C / 123 degrees F
ADC 14 Exhaust	OK	59 degrees C / 138 degrees F
ADC 14 ADC-XF1	OK	69 degrees C / 156 degrees F
ADC 14 ADC-XF0	OK	74 degrees C / 165 degrees F
ADC 15 Intake	OK	50 degrees C / 122 degrees F
ADC 15 Exhaust	OK	59 degrees C / 138 degrees F
ADC 15 ADC-XF1	OK	68 degrees C / 154 degrees F
ADC 15 ADC-XF0	OK	69 degrees C / 156 degrees F
ADC 16 Intake	OK	52 degrees C / 125 degrees F
ADC 16 Exhaust	OK	58 degrees C / 136 degrees F

	ADC 16 ADC-XF1	OK	68 degrees C / 154 degrees F
	ADC 16 ADC-XF0	OK	70 degrees C / 158 degrees F
	ADC 17 Intake	OK	52 degrees C / 125 degrees F
	ADC 17 Exhaust	OK	59 degrees C / 138 degrees F
	ADC 17 ADC-XF1	OK	69 degrees C / 156 degrees F
	ADC 17 ADC-XF0	OK	71 degrees C / 159 degrees F
	ADC 18 Intake	OK	53 degrees C / 127 degrees F
	ADC 18 Exhaust	OK	59 degrees C / 138 degrees F
	ADC 18 ADC-XF1	OK	68 degrees C / 154 degrees F
	ADC 18 ADC-XF0	OK	73 degrees C / 163 degrees F
	ADC 19 Intake	OK	50 degrees C / 122 degrees F
	ADC 19 Exhaust	OK	59 degrees C / 138 degrees F
	ADC 19 ADC-XF1	OK	68 degrees C / 154 degrees F
	ADC 19 ADC-XF0	OK	72 degrees C / 161 degrees F
Fans	Fan Tray 0 Fan 1	OK	7440 RPM
	Fan Tray 0 Fan 2	OK	7200 RPM
	Fan Tray 0 Fan 3	OK	6960 RPM
	Fan Tray 0 Fan 4	OK	7200 RPM
	Fan Tray 0 Fan 5	OK	7080 RPM
	Fan Tray 0 Fan 6	OK	6840 RPM
	Fan Tray 1 Fan 1	OK	6840 RPM
	Fan Tray 1 Fan 2	OK	6960 RPM
	Fan Tray 1 Fan 3	OK	6960 RPM
	Fan Tray 1 Fan 4	OK	7080 RPM
	Fan Tray 1 Fan 5	OK	6960 RPM
	Fan Tray 1 Fan 6	OK	6960 RPM
	Fan Tray 2 Fan 1	OK	8640 RPM
	Fan Tray 2 Fan 2	OK	8640 RPM
	Fan Tray 2 Fan 3	OK	8760 RPM
	Fan Tray 2 Fan 4	OK	8760 RPM
	Fan Tray 2 Fan 5	OK	8640 RPM
	Fan Tray 2 Fan 6	OK	8640 RPM
	Fan Tray 3 Fan 1	OK	8520 RPM
	Fan Tray 3 Fan 2	OK	8520 RPM
	Fan Tray 3 Fan 3	OK	8640 RPM
	Fan Tray 3 Fan 4	OK	8640 RPM
	Fan Tray 3 Fan 5	OK	8520 RPM
	Fan Tray 3 Fan 6	OK	8520 RPM

show chassis environment (MX2020 Router with MPC5EQ and MPC6E)

Class	Item	Status	Measurement
Temp	PSM 0	OK	32 degrees C / 89 degrees F
	PSM 1	OK	32 degrees C / 89 degrees F
	PSM 2	OK	32 degrees C / 89 degrees F
	PSM 3	OK	32 degrees C / 89 degrees F
	PSM 4	OK	32 degrees C / 89 degrees F
	PSM 5	OK	33 degrees C / 91 degrees F
	PSM 6	OK	32 degrees C / 89 degrees F
	PSM 7	OK	32 degrees C / 89 degrees F
	PSM 8	OK	32 degrees C / 89 degrees F
	PSM 9	Absent	
	PSM 10	Absent	
	PSM 11	Absent	
	PSM 12	OK	33 degrees C / 91 degrees F
	PSM 13	OK	33 degrees C / 91 degrees F
	PSM 14	OK	34 degrees C / 93 degrees F
	PSM 15	OK	34 degrees C / 93 degrees F
	PSM 16	OK	33 degrees C / 91 degrees F
	PSM 17	OK	33 degrees C / 91 degrees F
	PDM 0	OK	
	PDM 1	OK	
	PDM 2	OK	
	PDM 3	OK	
	CB 0 IntakeA-Zone0	OK	34 degrees C / 93 degrees F
	CB 0 IntakeB-Zone1	OK	26 degrees C / 78 degrees F
	CB 0 IntakeC-Zone0	OK	38 degrees C / 100 degrees F
	CB 0 ExhaustA-Zone0	OK	34 degrees C / 93 degrees F
	CB 0 ExhaustB-Zone1	OK	27 degrees C / 80 degrees F
	CB 0 TCBC-Zone0	OK	32 degrees C / 89 degrees F
	CB 1 IntakeA-Zone0	OK	24 degrees C / 75 degrees F
	CB 1 IntakeB-Zone1	OK	22 degrees C / 71 degrees F
	CB 1 IntakeC-Zone0	OK	34 degrees C / 93 degrees F
	CB 1 ExhaustA-Zone0	OK	31 degrees C / 87 degrees F
	CB 1 ExhaustB-Zone1	OK	24 degrees C / 75 degrees F
	CB 1 TCBC-Zone0	OK	27 degrees C / 80 degrees F
	SPMB 0 Intake	OK	25 degrees C / 77 degrees F
	SPMB 1 Intake	OK	23 degrees C / 73 degrees F
	Routing Engine 0	OK	28 degrees C / 82 degrees F
	Routing Engine 0 CPU	OK	25 degrees C / 77 degrees F
	Routing Engine 1	OK	25 degrees C / 77 degrees F

Routing Engine 1 CPU	OK	24 degrees C / 75 degrees F
SFB 0 Intake-Zone0	OK	45 degrees C / 113 degrees F
SFB 0 Exhaust-Zone1	OK	34 degrees C / 93 degrees F
SFB 0 IntakeA-Zone0	OK	32 degrees C / 89 degrees F
SFB 0 IntakeB-Zone1	OK	28 degrees C / 82 degrees F
SFB 0 Exhaust-Zone0	OK	36 degrees C / 96 degrees F
SFB 0 SFB-XF2-Zone1	OK	46 degrees C / 114 degrees F
SFB 0 SFB-XF1-Zone0	OK	48 degrees C / 118 degrees F
SFB 0 SFB-XF0-Zone0	OK	60 degrees C / 140 degrees F
SFB 1 Intake-Zone0	OK	44 degrees C / 111 degrees F
SFB 1 Exhaust-Zone1	OK	34 degrees C / 93 degrees F
SFB 1 IntakeA-Zone0	OK	35 degrees C / 95 degrees F
SFB 1 IntakeB-Zone1	OK	27 degrees C / 80 degrees F
SFB 1 Exhaust-Zone0	OK	37 degrees C / 98 degrees F
SFB 1 SFB-XF2-Zone1	OK	47 degrees C / 116 degrees F
SFB 1 SFB-XF1-Zone0	OK	49 degrees C / 120 degrees F
SFB 1 SFB-XF0-Zone0	OK	56 degrees C / 132 degrees F
SFB 2 Intake-Zone0	OK	41 degrees C / 105 degrees F
SFB 2 Exhaust-Zone1	OK	34 degrees C / 93 degrees F
SFB 2 IntakeA-Zone0	OK	35 degrees C / 95 degrees F
SFB 2 IntakeB-Zone1	OK	28 degrees C / 82 degrees F
SFB 2 Exhaust-Zone0	OK	37 degrees C / 98 degrees F
SFB 2 SFB-XF2-Zone1	OK	47 degrees C / 116 degrees F
SFB 2 SFB-XF1-Zone0	OK	55 degrees C / 131 degrees F
SFB 2 SFB-XF0-Zone0	OK	55 degrees C / 131 degrees F
SFB 3 Intake-Zone0	OK	43 degrees C / 109 degrees F
SFB 3 Exhaust-Zone1	OK	33 degrees C / 91 degrees F
SFB 3 IntakeA-Zone0	OK	35 degrees C / 95 degrees F
SFB 3 IntakeB-Zone1	OK	27 degrees C / 80 degrees F
SFB 3 Exhaust-Zone0	OK	36 degrees C / 96 degrees F
SFB 3 SFB-XF2-Zone1	OK	46 degrees C / 114 degrees F
SFB 3 SFB-XF1-Zone0	OK	46 degrees C / 114 degrees F
SFB 3 SFB-XF0-Zone0	OK	57 degrees C / 134 degrees F
SFB 4 Intake-Zone0	OK	36 degrees C / 96 degrees F
SFB 4 Exhaust-Zone1	OK	32 degrees C / 89 degrees F
SFB 4 IntakeA-Zone0	OK	31 degrees C / 87 degrees F
SFB 4 IntakeB-Zone1	OK	26 degrees C / 78 degrees F
SFB 4 Exhaust-Zone0	OK	32 degrees C / 89 degrees F
SFB 4 SFB-XF2-Zone1	OK	44 degrees C / 111 degrees F
SFB 4 SFB-XF1-Zone0	OK	45 degrees C / 113 degrees F
SFB 4 SFB-XF0-Zone0	OK	52 degrees C / 125 degrees F
SFB 5 Intake-Zone0	OK	31 degrees C / 87 degrees F
SFB 5 Exhaust-Zone1	OK	30 degrees C / 86 degrees F

SFB 5 IntakeA-Zone0	OK	26 degrees C / 78 degrees F
SFB 5 IntakeB-Zone1	OK	24 degrees C / 75 degrees F
SFB 5 Exhaust-Zone0	OK	29 degrees C / 84 degrees F
SFB 5 SFB-XF2-Zone1	OK	43 degrees C / 109 degrees F
SFB 5 SFB-XF1-Zone0	OK	47 degrees C / 116 degrees F
SFB 5 SFB-XF0-Zone0	OK	49 degrees C / 120 degrees F
SFB 6 Intake-Zone0	OK	30 degrees C / 86 degrees F
SFB 6 Exhaust-Zone1	OK	29 degrees C / 84 degrees F
SFB 6 IntakeA-Zone0	OK	25 degrees C / 77 degrees F
SFB 6 IntakeB-Zone1	OK	24 degrees C / 75 degrees F
SFB 6 Exhaust-Zone0	OK	29 degrees C / 84 degrees F
SFB 6 SFB-XF2-Zone1	OK	43 degrees C / 109 degrees F
SFB 6 SFB-XF1-Zone0	OK	44 degrees C / 111 degrees F
SFB 6 SFB-XF0-Zone0	OK	45 degrees C / 113 degrees F
SFB 7 Intake-Zone0	OK	31 degrees C / 87 degrees F
SFB 7 Exhaust-Zone1	OK	30 degrees C / 86 degrees F
SFB 7 IntakeA-Zone0	OK	26 degrees C / 78 degrees F
SFB 7 IntakeB-Zone1	OK	24 degrees C / 75 degrees F
SFB 7 Exhaust-Zone0	OK	28 degrees C / 82 degrees F
SFB 7 SFB-XF2-Zone1	OK	50 degrees C / 122 degrees F
SFB 7 SFB-XF1-Zone0	OK	43 degrees C / 109 degrees F
SFB 7 SFB-XF0-Zone0	OK	47 degrees C / 116 degrees F
FPC 0 Intake	OK	31 degrees C / 87 degrees F
FPC 0 Exhaust A	OK	49 degrees C / 120 degrees F
FPC 0 Exhaust B	OK	43 degrees C / 109 degrees F
FPC 0 XL TSen	OK	42 degrees C / 107 degrees F
FPC 0 XL Chip	OK	46 degrees C / 114 degrees F
FPC 0 XL_XR0 TSen	OK	42 degrees C / 107 degrees F
FPC 0 XL_XR0 Chip	OK	48 degrees C / 118 degrees F
FPC 0 XL_XR1 TSen	OK	42 degrees C / 107 degrees F
FPC 0 XL_XR1 Chip	OK	48 degrees C / 118 degrees F
FPC 0 XQ TSen	OK	42 degrees C / 107 degrees F
FPC 0 XQ Chip	OK	44 degrees C / 111 degrees F
FPC 0 XQ_XR0 TSen	OK	42 degrees C / 107 degrees F
FPC 0 XQ_XR0 Chip	OK	57 degrees C / 134 degrees F
FPC 0 XQ_XR1 TSen	OK	42 degrees C / 107 degrees F
FPC 0 XQ_XR1 Chip	OK	55 degrees C / 131 degrees F
FPC 0 XM 0 TSen	OK	48 degrees C / 118 degrees F
FPC 0 XM 0 Chip	OK	62 degrees C / 143 degrees F
FPC 0 XM 1 TSen	OK	48 degrees C / 118 degrees F
FPC 0 XM 1 Chip	OK	44 degrees C / 111 degrees F
FPC 0 PLX PCIe Switch TSe	OK	48 degrees C / 118 degrees F
FPC 0 PLX PCIe Switch Chi	OK	57 degrees C / 134 degrees F

FPC 1 Intake	OK	29 degrees C / 84 degrees F
FPC 1 Exhaust A	OK	36 degrees C / 96 degrees F
FPC 1 Exhaust B	OK	44 degrees C / 111 degrees F
FPC 1 LU 0 TSen	OK	38 degrees C / 100 degrees F
FPC 1 LU 0 Chip	OK	45 degrees C / 113 degrees F
FPC 1 LU 1 TSen	OK	38 degrees C / 100 degrees F
FPC 1 LU 1 Chip	OK	38 degrees C / 100 degrees F
FPC 1 LU 2 TSen	OK	38 degrees C / 100 degrees F
FPC 1 LU 2 Chip	OK	42 degrees C / 107 degrees F
FPC 1 LU 3 TSen	OK	38 degrees C / 100 degrees F
FPC 1 LU 3 Chip	OK	47 degrees C / 116 degrees F
FPC 1 XM 0 TSen	OK	38 degrees C / 100 degrees F
FPC 1 XM 0 Chip	OK	44 degrees C / 111 degrees F
FPC 1 XF 0 TSen	OK	38 degrees C / 100 degrees F
FPC 1 XF 0 Chip	OK	54 degrees C / 129 degrees F
FPC 1 PLX Switch TSen	OK	38 degrees C / 100 degrees F
FPC 1 PLX Switch Chip	OK	41 degrees C / 105 degrees F
FPC 2 Intake	OK	28 degrees C / 82 degrees F
FPC 2 Exhaust A	OK	28 degrees C / 82 degrees F
FPC 2 Exhaust B	OK	28 degrees C / 82 degrees F
FPC 2 LU 0 TSen	OK	40 degrees C / 104 degrees F
FPC 2 LU 0 Chip	OK	40 degrees C / 104 degrees F
FPC 2 LU 1 TSen	OK	40 degrees C / 104 degrees F
FPC 2 LU 1 Chip	OK	41 degrees C / 105 degrees F
FPC 2 LU 2 TSen	OK	40 degrees C / 104 degrees F
FPC 2 LU 2 Chip	OK	34 degrees C / 93 degrees F
FPC 2 LU 3 TSen	OK	40 degrees C / 104 degrees F
FPC 2 LU 3 Chip	OK	38 degrees C / 100 degrees F
FPC 2 XM 0 TSen	OK	40 degrees C / 104 degrees F
FPC 2 XM 0 Chip	OK	47 degrees C / 116 degrees F
FPC 2 XM 1 TSen	OK	40 degrees C / 104 degrees F
FPC 2 XM 1 Chip	OK	42 degrees C / 107 degrees F
FPC 2 PLX Switch TSen	OK	40 degrees C / 104 degrees F
FPC 2 PLX Switch Chip	OK	39 degrees C / 102 degrees F
FPC 3 Intake	OK	27 degrees C / 80 degrees F
FPC 3 Exhaust A	OK	38 degrees C / 100 degrees F
FPC 3 Exhaust B	OK	31 degrees C / 87 degrees F
FPC 3 QX 0 TSen	OK	38 degrees C / 100 degrees F
FPC 3 QX 0 Chip	OK	42 degrees C / 107 degrees F
FPC 3 LU 0 TCAM TSen	OK	38 degrees C / 100 degrees F
FPC 3 LU 0 TCAM Chip	OK	43 degrees C / 109 degrees F
FPC 3 LU 0 TSen	OK	38 degrees C / 100 degrees F
FPC 3 LU 0 Chip	OK	42 degrees C / 107 degrees F

FPC 3 MQ 0 TSen	OK	38 degrees C / 100 degrees F
FPC 3 MQ 0 Chip	OK	39 degrees C / 102 degrees F
FPC 3 QX 1 TSen	OK	32 degrees C / 89 degrees F
FPC 3 QX 1 Chip	OK	36 degrees C / 96 degrees F
FPC 3 LU 1 TCAM TSen	OK	32 degrees C / 89 degrees F
FPC 3 LU 1 TCAM Chip	OK	35 degrees C / 95 degrees F
FPC 3 LU 1 TSen	OK	32 degrees C / 89 degrees F
FPC 3 LU 1 Chip	OK	37 degrees C / 98 degrees F
FPC 3 MQ 1 TSen	OK	32 degrees C / 89 degrees F
FPC 3 MQ 1 Chip	OK	36 degrees C / 96 degrees F
FPC 4 Intake	OK	29 degrees C / 84 degrees F
FPC 4 Exhaust A	OK	36 degrees C / 96 degrees F
FPC 4 Exhaust B	OK	40 degrees C / 104 degrees F
FPC 4 XL TSen	OK	39 degrees C / 102 degrees F
FPC 4 XL Chip	OK	42 degrees C / 107 degrees F
FPC 4 XL_XR0 TSen	OK	39 degrees C / 102 degrees F
FPC 4 XL_XR0 Chip	OK	45 degrees C / 113 degrees F
FPC 4 XL_XR1 TSen	OK	39 degrees C / 102 degrees F
FPC 4 XL_XR1 Chip	OK	46 degrees C / 114 degrees F
FPC 4 XQ TSen	OK	39 degrees C / 102 degrees F
FPC 4 XQ Chip	OK	42 degrees C / 107 degrees F
FPC 4 XQ_XR0 TSen	OK	39 degrees C / 102 degrees F
FPC 4 XQ_XR0 Chip	OK	54 degrees C / 129 degrees F
FPC 4 XQ_XR1 TSen	OK	39 degrees C / 102 degrees F
FPC 4 XQ_XR1 Chip	OK	53 degrees C / 127 degrees F
FPC 4 XM 0 TSen	OK	45 degrees C / 113 degrees F
FPC 4 XM 0 Chip	OK	59 degrees C / 138 degrees F
FPC 4 XM 1 TSen	OK	45 degrees C / 113 degrees F
FPC 4 XM 1 Chip	OK	41 degrees C / 105 degrees F
FPC 4 PLX PCIe Switch TSe	OK	45 degrees C / 113 degrees F
FPC 4 PLX PCIe Switch Chi	OK	58 degrees C / 136 degrees F
FPC 5 Intake	OK	29 degrees C / 84 degrees F
FPC 5 Exhaust A	OK	33 degrees C / 91 degrees F
FPC 5 Exhaust B	OK	39 degrees C / 102 degrees F
FPC 5 LU 0 TSen	OK	40 degrees C / 104 degrees F
FPC 5 LU 0 Chip	OK	40 degrees C / 104 degrees F
FPC 5 LU 1 TSen	OK	40 degrees C / 104 degrees F
FPC 5 LU 1 Chip	OK	45 degrees C / 113 degrees F
FPC 5 LU 2 TSen	OK	40 degrees C / 104 degrees F
FPC 5 LU 2 Chip	OK	40 degrees C / 104 degrees F
FPC 5 LU 3 TSen	OK	40 degrees C / 104 degrees F
FPC 5 LU 3 Chip	OK	46 degrees C / 114 degrees F
FPC 5 MQ 0 TSen	OK	32 degrees C / 89 degrees F

```

FPC 5 MQ 0 Chip           OK           33 degrees C / 91 degrees F
FPC 5 MQ 1 TSen          OK           32 degrees C / 89 degrees F
FPC 5 MQ 1 Chip           OK           35 degrees C / 95 degrees F
FPC 5 MQ 2 TSen          OK           32 degrees C / 89 degrees F
FPC 5 MQ 2 Chip           OK           32 degrees C / 89 degrees F
FPC 5 MQ 3 TSen          OK           32 degrees C / 89 degrees F
FPC 5 MQ 3 Chip           OK           32 degrees C / 89 degrees F
FPC 9 Intake              OK           25 degrees C / 77 degrees F
FPC 9 Exhaust A           OK           37 degrees C / 98 degrees F
FPC 9 Exhaust B           OK           40 degrees C / 104 degrees F
FPC 9 XL 0 TSen           OK           40 degrees C / 104 degrees F

```

...

show chassis environment (MX2010 Router)

```

user@host> show chassis environment
Class Item                Status      Measurement
Temp PSM 0                  OK          7 degrees C / 44 degrees F
      PSM 1                  OK          7 degrees C / 44 degrees F
      PSM 2                  OK          7 degrees C / 44 degrees F
      PSM 3                  OK          6 degrees C / 42 degrees F
      PSM 4                  OK          6 degrees C / 42 degrees F
      PSM 5                  OK          6 degrees C / 42 degrees F
      PSM 6                  OK          6 degrees C / 42 degrees F
      PSM 7                  OK          7 degrees C / 44 degrees F
      PSM 8                  OK          7 degrees C / 44 degrees F
      PDM 0                  OK
      PDM 1                  Absent
      CB 0 IntakeA-Zone0     OK          14 degrees C / 57 degrees F
      CB 0 IntakeB-Zone1     OK          7 degrees C / 44 degrees F
      CB 0 IntakeC-Zone0     OK          22 degrees C / 71 degrees F
      CB 0 ExhaustA-Zone0    OK          14 degrees C / 57 degrees F
      CB 0 ExhaustB-Zone1    OK          9 degrees C / 48 degrees F
      CB 0 TCBC-Zone0        OK          11 degrees C / 51 degrees F
      CB 1 IntakeA-Zone0     OK          9 degrees C / 48 degrees F
      CB 1 IntakeB-Zone1     OK          5 degrees C / 41 degrees F
      CB 1 IntakeC-Zone0     OK          20 degrees C / 68 degrees F
      CB 1 ExhaustA-Zone0    OK          12 degrees C / 53 degrees F
      CB 1 ExhaustB-Zone1    OK          7 degrees C / 44 degrees F
      CB 1 TCBC-Zone0        OK          10 degrees C / 50 degrees F
      SPMB 0 Intake           OK          5 degrees C / 41 degrees F

```

SPMB 1 Intake	OK	4 degrees C / 39 degrees F
Routing Engine 0	OK	9 degrees C / 48 degrees F
Routing Engine 0 CPU	OK	9 degrees C / 48 degrees F
Routing Engine 1	OK	6 degrees C / 42 degrees F
Routing Engine 1 CPU	OK	6 degrees C / 42 degrees F
SFB 0 Intake-Zone0	OK	26 degrees C / 78 degrees F
SFB 0 Exhaust-Zone1	OK	17 degrees C / 62 degrees F
SFB 0 IntakeA-Zone0	OK	16 degrees C / 60 degrees F
SFB 0 IntakeB-Zone1	OK	11 degrees C / 51 degrees F
SFB 0 Exhaust-Zone0	OK	18 degrees C / 64 degrees F
SFB 0 SFB-XF2-Zone1	OK	25 degrees C / 77 degrees F
SFB 0 SFB-XF1-Zone0	OK	23 degrees C / 73 degrees F
SFB 0 SFB-XF0-Zone0	OK	33 degrees C / 91 degrees F
SFB 1 Intake-Zone0	OK	27 degrees C / 80 degrees F
SFB 1 Exhaust-Zone1	OK	15 degrees C / 59 degrees F
SFB 1 IntakeA-Zone0	OK	20 degrees C / 68 degrees F
SFB 1 IntakeB-Zone1	OK	10 degrees C / 50 degrees F
SFB 1 Exhaust-Zone0	OK	19 degrees C / 66 degrees F
SFB 1 SFB-XF2-Zone1	OK	26 degrees C / 78 degrees F
SFB 1 SFB-XF1-Zone0	OK	27 degrees C / 80 degrees F
SFB 1 SFB-XF0-Zone0	OK	32 degrees C / 89 degrees F
SFB 2 Intake-Zone0	OK	21 degrees C / 69 degrees F
SFB 2 Exhaust-Zone1	OK	13 degrees C / 55 degrees F
SFB 2 IntakeA-Zone0	OK	18 degrees C / 64 degrees F
SFB 2 IntakeB-Zone1	OK	9 degrees C / 48 degrees F
SFB 2 Exhaust-Zone0	OK	16 degrees C / 60 degrees F
SFB 2 SFB-XF2-Zone1	OK	24 degrees C / 75 degrees F
SFB 2 SFB-XF1-Zone0	OK	21 degrees C / 69 degrees F
SFB 2 SFB-XF0-Zone0	OK	26 degrees C / 78 degrees F
SFB 4 Intake-Zone0	OK	28 degrees C / 82 degrees F
SFB 4 Exhaust-Zone1	OK	16 degrees C / 60 degrees F
SFB 4 IntakeA-Zone0	OK	18 degrees C / 64 degrees F
SFB 4 IntakeB-Zone1	OK	11 degrees C / 51 degrees F
SFB 4 Exhaust-Zone0	OK	19 degrees C / 66 degrees F
SFB 4 SFB-XF2-Zone1	OK	27 degrees C / 80 degrees F
SFB 4 SFB-XF1-Zone0	OK	27 degrees C / 80 degrees F
SFB 4 SFB-XF0-Zone0	OK	32 degrees C / 89 degrees F
SFB 5 Intake-Zone0	OK	22 degrees C / 71 degrees F
SFB 5 Exhaust-Zone1	OK	14 degrees C / 57 degrees F
SFB 5 IntakeA-Zone0	OK	18 degrees C / 64 degrees F
SFB 5 IntakeB-Zone1	OK	10 degrees C / 50 degrees F
SFB 5 Exhaust-Zone0	OK	17 degrees C / 62 degrees F
SFB 5 SFB-XF2-Zone1	OK	22 degrees C / 71 degrees F

SFB 5 SFB-XF1-Zone0	OK	29 degrees C / 84 degrees F
SFB 5 SFB-XF0-Zone0	OK	27 degrees C / 80 degrees F
SFB 6 Intake-Zone0	OK	27 degrees C / 80 degrees F
SFB 6 Exhaust-Zone1	OK	13 degrees C / 55 degrees F
SFB 6 IntakeA-Zone0	OK	19 degrees C / 66 degrees F
SFB 6 IntakeB-Zone1	OK	10 degrees C / 50 degrees F
SFB 6 Exhaust-Zone0	OK	20 degrees C / 68 degrees F
SFB 6 SFB-XF2-Zone1	OK	24 degrees C / 75 degrees F
SFB 6 SFB-XF1-Zone0	OK	32 degrees C / 89 degrees F
SFB 6 SFB-XF0-Zone0	OK	33 degrees C / 91 degrees F
SFB 7 Intake-Zone0	OK	25 degrees C / 77 degrees F
SFB 7 Exhaust-Zone1	OK	13 degrees C / 55 degrees F
SFB 7 IntakeA-Zone0	OK	14 degrees C / 57 degrees F
SFB 7 IntakeB-Zone1	OK	8 degrees C / 46 degrees F
SFB 7 Exhaust-Zone0	OK	17 degrees C / 62 degrees F
SFB 7 SFB-XF2-Zone1	OK	21 degrees C / 69 degrees F
SFB 7 SFB-XF1-Zone0	OK	21 degrees C / 69 degrees F
SFB 7 SFB-XF0-Zone0	OK	33 degrees C / 91 degrees F
FPC 0 Intake	OK	13 degrees C / 55 degrees F
FPC 0 Exhaust A	OK	13 degrees C / 55 degrees F
FPC 0 Exhaust B	OK	14 degrees C / 57 degrees F
FPC 0 LU 0 TSen	OK	28 degrees C / 82 degrees F
FPC 0 LU 0 Chip	OK	25 degrees C / 77 degrees F
FPC 0 LU 1 TSen	OK	28 degrees C / 82 degrees F
FPC 0 LU 1 Chip	OK	27 degrees C / 80 degrees F
FPC 0 LU 2 TSen	OK	28 degrees C / 82 degrees F
FPC 0 LU 2 Chip	OK	19 degrees C / 66 degrees F
FPC 0 LU 3 TSen	OK	28 degrees C / 82 degrees F
FPC 0 LU 3 Chip	OK	23 degrees C / 73 degrees F
FPC 0 XM 0 TSen	OK	28 degrees C / 82 degrees F
FPC 0 XM 0 Chip	OK	33 degrees C / 91 degrees F
FPC 0 XM 1 TSen	OK	28 degrees C / 82 degrees F
FPC 0 XM 1 Chip	OK	26 degrees C / 78 degrees F
FPC 0 PLX Switch TSen	OK	28 degrees C / 82 degrees F
FPC 0 PLX Switch Chip	OK	26 degrees C / 78 degrees F
FPC 1 Intake	OK	10 degrees C / 50 degrees F
FPC 1 Exhaust A	OK	24 degrees C / 75 degrees F
FPC 1 Exhaust B	OK	28 degrees C / 82 degrees F
FPC 1 LU 0 TSen	OK	22 degrees C / 71 degrees F
FPC 1 LU 0 Chip	OK	31 degrees C / 87 degrees F
FPC 1 LU 1 TSen	OK	22 degrees C / 71 degrees F
FPC 1 LU 1 Chip	OK	21 degrees C / 69 degrees F
FPC 1 LU 2 TSen	OK	22 degrees C / 71 degrees F

FPC 1 LU 2 Chip	OK	25 degrees C / 77 degrees F
FPC 1 LU 3 TSen	OK	22 degrees C / 71 degrees F
FPC 1 LU 3 Chip	OK	33 degrees C / 91 degrees F
FPC 1 XM 0 TSen	OK	22 degrees C / 71 degrees F
FPC 1 XM 0 Chip	OK	30 degrees C / 86 degrees F
FPC 1 XF 0 TSen	OK	22 degrees C / 71 degrees F
FPC 1 XF 0 Chip	OK	37 degrees C / 98 degrees F
FPC 1 PLX Switch TSen	OK	22 degrees C / 71 degrees F
FPC 1 PLX Switch Chip	OK	22 degrees C / 71 degrees F
FPC 2 Intake	OK	9 degrees C / 48 degrees F
FPC 2 Exhaust A	OK	10 degrees C / 50 degrees F
FPC 2 Exhaust B	OK	10 degrees C / 50 degrees F
FPC 2 LU 0 TSen	OK	26 degrees C / 78 degrees F
FPC 2 LU 0 Chip	OK	25 degrees C / 77 degrees F
FPC 2 LU 1 TSen	OK	26 degrees C / 78 degrees F
FPC 2 LU 1 Chip	OK	26 degrees C / 78 degrees F
FPC 2 LU 2 TSen	OK	26 degrees C / 78 degrees F
FPC 2 LU 2 Chip	OK	17 degrees C / 62 degrees F
FPC 2 LU 3 TSen	OK	26 degrees C / 78 degrees F
FPC 2 LU 3 Chip	OK	22 degrees C / 71 degrees F
FPC 2 XM 0 TSen	OK	26 degrees C / 78 degrees F
FPC 2 XM 0 Chip	OK	34 degrees C / 93 degrees F
FPC 2 XM 1 TSen	OK	26 degrees C / 78 degrees F
FPC 2 XM 1 Chip	OK	26 degrees C / 78 degrees F
FPC 2 PLX Switch TSen	OK	26 degrees C / 78 degrees F
FPC 2 PLX Switch Chip	OK	20 degrees C / 68 degrees F
FPC 3 Intake	OK	12 degrees C / 53 degrees F
FPC 3 Exhaust A	OK	16 degrees C / 60 degrees F
FPC 3 Exhaust B	OK	26 degrees C / 78 degrees F
FPC 3 LU 0 TSen	OK	23 degrees C / 73 degrees F
FPC 3 LU 0 Chip	OK	26 degrees C / 78 degrees F
FPC 3 LU 1 TSen	OK	23 degrees C / 73 degrees F
FPC 3 LU 1 Chip	OK	27 degrees C / 80 degrees F
FPC 3 LU 2 TSen	OK	23 degrees C / 73 degrees F
FPC 3 LU 2 Chip	OK	22 degrees C / 71 degrees F
FPC 3 LU 3 TSen	OK	23 degrees C / 73 degrees F
FPC 3 LU 3 Chip	OK	21 degrees C / 69 degrees F
FPC 3 MQ 0 TSen	OK	15 degrees C / 59 degrees F
FPC 3 MQ 0 Chip	OK	18 degrees C / 64 degrees F
FPC 3 MQ 1 TSen	OK	15 degrees C / 59 degrees F
FPC 3 MQ 1 Chip	OK	20 degrees C / 68 degrees F
FPC 3 MQ 2 TSen	OK	15 degrees C / 59 degrees F
FPC 3 MQ 2 Chip	OK	17 degrees C / 62 degrees F

FPC 3 MQ 3 TSen	OK	15 degrees C / 59 degrees F
FPC 3 MQ 3 Chip	OK	16 degrees C / 60 degrees F
FPC 4 Intake	OK	11 degrees C / 51 degrees F
FPC 4 Exhaust A	OK	22 degrees C / 71 degrees F
FPC 4 Exhaust B	OK	28 degrees C / 82 degrees F
FPC 4 LU 0 TSen	OK	22 degrees C / 71 degrees F
FPC 4 LU 0 Chip	OK	33 degrees C / 91 degrees F
FPC 4 LU 1 TSen	OK	22 degrees C / 71 degrees F
FPC 4 LU 1 Chip	OK	21 degrees C / 69 degrees F
FPC 4 LU 2 TSen	OK	22 degrees C / 71 degrees F
FPC 4 LU 2 Chip	OK	26 degrees C / 78 degrees F
FPC 4 LU 3 TSen	OK	22 degrees C / 71 degrees F
FPC 4 LU 3 Chip	OK	33 degrees C / 91 degrees F
FPC 4 XM 0 TSen	OK	22 degrees C / 71 degrees F
FPC 4 XM 0 Chip	OK	30 degrees C / 86 degrees F
FPC 4 XF 0 TSen	OK	22 degrees C / 71 degrees F
FPC 4 XF 0 Chip	OK	37 degrees C / 98 degrees F
FPC 4 PLX Switch TSen	OK	22 degrees C / 71 degrees F
FPC 4 PLX Switch Chip	OK	23 degrees C / 73 degrees F
FPC 5 Intake	OK	12 degrees C / 53 degrees F
FPC 5 Exhaust A	OK	12 degrees C / 53 degrees F
FPC 5 Exhaust B	OK	12 degrees C / 53 degrees F
FPC 5 LU 0 TSen	OK	27 degrees C / 80 degrees F
FPC 5 LU 0 Chip	OK	28 degrees C / 82 degrees F
FPC 5 LU 1 TSen	OK	27 degrees C / 80 degrees F
FPC 5 LU 1 Chip	OK	27 degrees C / 80 degrees F
FPC 5 LU 2 TSen	OK	27 degrees C / 80 degrees F
FPC 5 LU 2 Chip	OK	19 degrees C / 66 degrees F
FPC 5 LU 3 TSen	OK	27 degrees C / 80 degrees F
FPC 5 LU 3 Chip	OK	22 degrees C / 71 degrees F
FPC 5 XM 0 TSen	OK	27 degrees C / 80 degrees F
FPC 5 XM 0 Chip	OK	36 degrees C / 96 degrees F
FPC 5 XM 1 TSen	OK	27 degrees C / 80 degrees F
FPC 5 XM 1 Chip	OK	26 degrees C / 78 degrees F
FPC 5 PLX Switch TSen	OK	27 degrees C / 80 degrees F
FPC 5 PLX Switch Chip	OK	24 degrees C / 75 degrees F
FPC 6 Intake	OK	12 degrees C / 53 degrees F
FPC 6 Exhaust A	OK	17 degrees C / 62 degrees F
FPC 6 Exhaust B	OK	28 degrees C / 82 degrees F
FPC 6 LU 0 TSen	OK	24 degrees C / 75 degrees F
FPC 6 LU 0 Chip	OK	29 degrees C / 84 degrees F
FPC 6 LU 1 TSen	OK	24 degrees C / 75 degrees F
FPC 6 LU 1 Chip	OK	30 degrees C / 86 degrees F

FPC 6 LU 2 TSen	OK	24 degrees C / 75 degrees F
FPC 6 LU 2 Chip	OK	24 degrees C / 75 degrees F
FPC 6 LU 3 TSen	OK	24 degrees C / 75 degrees F
FPC 6 LU 3 Chip	OK	22 degrees C / 71 degrees F
FPC 6 MQ 0 TSen	OK	16 degrees C / 60 degrees F
FPC 6 MQ 0 Chip	OK	19 degrees C / 66 degrees F
FPC 6 MQ 1 TSen	OK	16 degrees C / 60 degrees F
FPC 6 MQ 1 Chip	OK	20 degrees C / 68 degrees F
FPC 6 MQ 2 TSen	OK	16 degrees C / 60 degrees F
FPC 6 MQ 2 Chip	OK	17 degrees C / 62 degrees F
FPC 6 MQ 3 TSen	OK	16 degrees C / 60 degrees F
FPC 6 MQ 3 Chip	OK	16 degrees C / 60 degrees F
FPC 7 Intake	OK	10 degrees C / 50 degrees F
FPC 7 Exhaust A	OK	10 degrees C / 50 degrees F
FPC 7 Exhaust B	OK	11 degrees C / 51 degrees F
FPC 7 LU 0 TSen	OK	26 degrees C / 78 degrees F
FPC 7 LU 0 Chip	OK	26 degrees C / 78 degrees F
FPC 7 LU 1 TSen	OK	26 degrees C / 78 degrees F
FPC 7 LU 1 Chip	OK	29 degrees C / 84 degrees F
FPC 7 LU 2 TSen	OK	26 degrees C / 78 degrees F
FPC 7 LU 2 Chip	OK	19 degrees C / 66 degrees F
FPC 7 LU 3 TSen	OK	26 degrees C / 78 degrees F
FPC 7 LU 3 Chip	OK	24 degrees C / 75 degrees F
FPC 7 XM 0 TSen	OK	26 degrees C / 78 degrees F
FPC 7 XM 0 Chip	OK	34 degrees C / 93 degrees F
FPC 7 XM 1 TSen	OK	26 degrees C / 78 degrees F
FPC 7 XM 1 Chip	OK	32 degrees C / 89 degrees F
FPC 7 PLX Switch TSen	OK	26 degrees C / 78 degrees F
FPC 7 PLX Switch Chip	OK	22 degrees C / 71 degrees F
FPC 8 Intake	OK	10 degrees C / 50 degrees F
FPC 8 Exhaust A	OK	22 degrees C / 71 degrees F
FPC 8 Exhaust B	OK	28 degrees C / 82 degrees F
FPC 8 LU 0 TSen	OK	20 degrees C / 68 degrees F
FPC 8 LU 0 Chip	OK	33 degrees C / 91 degrees F
FPC 8 LU 1 TSen	OK	20 degrees C / 68 degrees F
FPC 8 LU 1 Chip	OK	23 degrees C / 73 degrees F
FPC 8 LU 2 TSen	OK	20 degrees C / 68 degrees F
FPC 8 LU 2 Chip	OK	26 degrees C / 78 degrees F
FPC 8 LU 3 TSen	OK	20 degrees C / 68 degrees F
FPC 8 LU 3 Chip	OK	33 degrees C / 91 degrees F
FPC 8 XM 0 TSen	OK	20 degrees C / 68 degrees F
FPC 8 XM 0 Chip	OK	29 degrees C / 84 degrees F
FPC 8 XF 0 TSen	OK	20 degrees C / 68 degrees F

FPC 8 XF 0 Chip	OK	38 degrees C / 100 degrees F
FPC 8 PLX Switch TSen	OK	20 degrees C / 68 degrees F
FPC 8 PLX Switch Chip	OK	24 degrees C / 75 degrees F
FPC 9 Intake	OK	11 degrees C / 51 degrees F
FPC 9 Exhaust A	OK	11 degrees C / 51 degrees F
FPC 9 Exhaust B	OK	11 degrees C / 51 degrees F
FPC 9 LU 0 TSen	OK	25 degrees C / 77 degrees F
FPC 9 LU 0 Chip	OK	24 degrees C / 75 degrees F
FPC 9 LU 1 TSen	OK	25 degrees C / 77 degrees F
FPC 9 LU 1 Chip	OK	26 degrees C / 78 degrees F
FPC 9 LU 2 TSen	OK	25 degrees C / 77 degrees F
FPC 9 LU 2 Chip	OK	16 degrees C / 60 degrees F
FPC 9 LU 3 TSen	OK	25 degrees C / 77 degrees F
FPC 9 LU 3 Chip	OK	21 degrees C / 69 degrees F
FPC 9 XM 0 TSen	OK	25 degrees C / 77 degrees F
FPC 9 XM 0 Chip	OK	32 degrees C / 89 degrees F
FPC 9 XM 1 TSen	OK	25 degrees C / 77 degrees F
FPC 9 XM 1 Chip	OK	25 degrees C / 77 degrees F
FPC 9 PLX Switch TSen	OK	25 degrees C / 77 degrees F
FPC 9 PLX Switch Chip	OK	21 degrees C / 69 degrees F
ADC 0 Intake	OK	12 degrees C / 53 degrees F
ADC 0 Exhaust	OK	20 degrees C / 68 degrees F
ADC 0 ADC-XF1	OK	26 degrees C / 78 degrees F
ADC 0 ADC-XF0	OK	32 degrees C / 89 degrees F
ADC 1 Intake	OK	11 degrees C / 51 degrees F
ADC 1 Exhaust	OK	21 degrees C / 69 degrees F
ADC 1 ADC-XF1	OK	24 degrees C / 75 degrees F
ADC 1 ADC-XF0	OK	31 degrees C / 87 degrees F
ADC 2 Intake	OK	14 degrees C / 57 degrees F
ADC 2 Exhaust	OK	21 degrees C / 69 degrees F
ADC 2 ADC-XF1	OK	28 degrees C / 82 degrees F
ADC 2 ADC-XF0	OK	34 degrees C / 93 degrees F
ADC 3 Intake	OK	13 degrees C / 55 degrees F
ADC 3 Exhaust	OK	19 degrees C / 66 degrees F
ADC 3 ADC-XF1	OK	24 degrees C / 75 degrees F
ADC 3 ADC-XF0	OK	31 degrees C / 87 degrees F
ADC 4 Intake	OK	9 degrees C / 48 degrees F
ADC 4 Exhaust	OK	22 degrees C / 71 degrees F
ADC 4 ADC-XF1	OK	28 degrees C / 82 degrees F
ADC 4 ADC-XF0	OK	35 degrees C / 95 degrees F
ADC 5 Intake	OK	12 degrees C / 53 degrees F
ADC 5 Exhaust	OK	22 degrees C / 71 degrees F
ADC 5 ADC-XF1	OK	28 degrees C / 82 degrees F

	ADC 5 ADC-XF0	OK	34 degrees C / 93 degrees F
	ADC 6 Intake	OK	11 degrees C / 51 degrees F
	ADC 6 Exhaust	OK	21 degrees C / 69 degrees F
	ADC 6 ADC-XF1	OK	26 degrees C / 78 degrees F
ADC 6	ADC-XF0	OK	35 degrees C / 95 degrees F
	ADC 7 Intake	OK	14 degrees C / 57 degrees F
	ADC 7 Exhaust	OK	22 degrees C / 71 degrees F
	ADC 7 ADC-XF1	OK	26 degrees C / 78 degrees F
	ADC 7 ADC-XF0	OK	34 degrees C / 93 degrees F
	ADC 8 Intake	OK	14 degrees C / 57 degrees F
	ADC 8 Exhaust	OK	21 degrees C / 69 degrees F
	ADC 8 ADC-XF1	OK	24 degrees C / 75 degrees F
	ADC 8 ADC-XF0	OK	31 degrees C / 87 degrees F
	ADC 9 Intake	OK	10 degrees C / 50 degrees F
	ADC 9 Exhaust	OK	22 degrees C / 71 degrees F
	ADC 9 ADC-XF1	OK	28 degrees C / 82 degrees F
	ADC 9 ADC-XF0	OK	36 degrees C / 96 degrees F
Fans	Fan Tray 0 Fan 1	OK	3480 RPM
	Fan Tray 0 Fan 2	OK	3480 RPM
	Fan Tray 0 Fan 3	OK	3480 RPM
	Fan Tray 0 Fan 4	OK	3360 RPM
	Fan Tray 0 Fan 5	OK	3360 RPM
	Fan Tray 0 Fan 6	OK	3480 RPM
	Fan Tray 1 Fan 1	OK	3360 RPM
	Fan Tray 1 Fan 2	OK	3360 RPM
	Fan Tray 1 Fan 3	OK	3360 RPM
	Fan Tray 1 Fan 4	OK	3480 RPM
	Fan Tray 1 Fan 5	OK	3480 RPM
	Fan Tray 1 Fan 6	OK	3480 RPM
	Fan Tray 2 Fan 1	OK	3360 RPM
	Fan Tray 2 Fan 2	OK	3360 RPM
	Fan Tray 2 Fan 3	OK	3480 RPM
	Fan Tray 2 Fan 4	OK	3480 RPM
	Fan Tray 2 Fan 5	OK	3360 RPM
	Fan Tray 2 Fan 6	OK	3480 RPM
	Fan Tray 3 Fan 1	OK	3360 RPM
	Fan Tray 3 Fan 2	OK	3360 RPM
	Fan Tray 3 Fan 3	OK	3480 RPM
	Fan Tray 3 Fan 4	OK	3480 RPM
	Fan Tray 3 Fan 5	OK	3480 RPM
	Fan Tray 3 Fan 6	OK	3360 RPM

show chassis environment (MX2008 Router)

```

user@host>show chassis environment
Class Item                               Status Measurement
Temp PSM 0                               Absent
      PSM 1                               OK          29 degrees C / 84 degrees F
      PSM 2                               OK          30 degrees C / 86 degrees F
      PSM 3                               OK          29 degrees C / 84 degrees F
      PSM 4                               OK          29 degrees C / 84 degrees F
      PSM 5                               OK          30 degrees C / 86 degrees F
      PSM 6                               OK          29 degrees C / 84 degrees F
      PSM 7                               OK          31 degrees C / 87 degrees F
      PSM 8                               Absent
      PDM 0                               OK
      PDM 1                               OK
      CB 0 Inlet1                          OK          37 degrees C / 98 degrees F
      CB 0 Inlet2                          OK          45 degrees C / 113 degrees F
      CB 0 Inlet3                          OK          44 degrees C / 111 degrees F
      CB 0 Inlet4                          OK          41 degrees C / 105 degrees F
      CB 0 Exhaust1                        OK          30 degrees C / 86 degrees F
      CB 0 Exhaust2                        OK          40 degrees C / 104 degrees F
      CB 0 Exhaust3                        OK          48 degrees C / 118 degrees F
      CB 0 Exhaust4                        OK          46 degrees C / 114 degrees F
      CB 1 Inlet1                          OK          30 degrees C / 86 degrees F
      CB 1 Inlet2                          OK          31 degrees C / 87 degrees F
      CB 1 Inlet3                          OK          29 degrees C / 84 degrees F
      CB 1 Inlet4                          OK          32 degrees C / 89 degrees F
      CB 1 Exhaust1                        OK          30 degrees C / 86 degrees F
      CB 1 Exhaust2                        OK          33 degrees C / 91 degrees F
      CB 1 Exhaust3                        OK          34 degrees C / 93 degrees F
      CB 1 Exhaust4                        OK          34 degrees C / 93 degrees F
      Routing Engine 0                     OK
      Routing Engine 0 CPU                  OK          75 degrees C / 167 degrees F
      Routing Engine 1                     OK
      Routing Engine 1 CPU                  OK          46 degrees C / 114 degrees F
      SFB 0 Inlet2                          OK          44 degrees C / 111 degrees F
      SFB 0 Exhaust1                       OK          39 degrees C / 102 degrees F
      SFB 0 Inlet1                          OK          41 degrees C / 105 degrees F
      SFB 0 Exhaust2                       OK          45 degrees C / 113 degrees F
      SFB 0 SFB2-PF-local                   OK          45 degrees C / 113 degrees F
      SFB 0 SFB2-PF-die                    OK          51 degrees C / 123 degrees F
      SFB 1 Inlet2                          OK          30 degrees C / 86 degrees F

```

SFB 1 Exhaust1	OK	27 degrees C / 80 degrees F
SFB 1 Inlet1	OK	28 degrees C / 82 degrees F
SFB 1 Exhaust2	OK	31 degrees C / 87 degrees F
SFB 1 SFB2-PF-local	OK	30 degrees C / 86 degrees F
SFB 1 SFB2-PF-die	OK	37 degrees C / 98 degrees F
SFB 2 Inlet2	OK	28 degrees C / 82 degrees F
SFB 2 Exhaust1	OK	26 degrees C / 78 degrees F
SFB 2 Inlet1	OK	27 degrees C / 80 degrees F
SFB 2 Exhaust2	OK	28 degrees C / 82 degrees F
SFB 2 SFB2-PF-local	OK	27 degrees C / 80 degrees F
SFB 2 SFB2-PF-die	OK	33 degrees C / 91 degrees F
SFB 3 Inlet2	OK	28 degrees C / 82 degrees F
SFB 3 Exhaust1	OK	26 degrees C / 78 degrees F
SFB 3 Inlet1	OK	26 degrees C / 78 degrees F
SFB 3 Exhaust2	OK	28 degrees C / 82 degrees F
SFB 3 SFB2-PF-local	OK	27 degrees C / 80 degrees F
SFB 3 SFB2-PF-die	OK	33 degrees C / 91 degrees F
SFB 4 Inlet2	OK	28 degrees C / 82 degrees F
SFB 4 Exhaust1	OK	26 degrees C / 78 degrees F
SFB 4 Inlet1	OK	26 degrees C / 78 degrees F
SFB 4 Exhaust2	OK	28 degrees C / 82 degrees F
SFB 4 SFB2-PF-local	OK	27 degrees C / 80 degrees F
SFB 4 SFB2-PF-die	OK	32 degrees C / 89 degrees F
SFB 5 Inlet2	OK	29 degrees C / 84 degrees F
SFB 5 Exhaust1	OK	27 degrees C / 80 degrees F
SFB 5 Inlet1	OK	28 degrees C / 82 degrees F
SFB 5 Exhaust2	OK	29 degrees C / 84 degrees F
SFB 5 SFB2-PF-local	OK	28 degrees C / 82 degrees F
SFB 5 SFB2-PF-die	OK	34 degrees C / 93 degrees F
SFB 6 Inlet2	OK	33 degrees C / 91 degrees F
SFB 6 Exhaust1	OK	32 degrees C / 89 degrees F
SFB 6 Inlet1	OK	32 degrees C / 89 degrees F
SFB 6 Exhaust2	OK	34 degrees C / 93 degrees F
SFB 6 SFB2-PF-local	OK	33 degrees C / 91 degrees F
SFB 6 SFB2-PF-die	OK	40 degrees C / 104 degrees F
SFB 7 Inlet2	OK	29 degrees C / 84 degrees F
SFB 7 Exhaust1	OK	28 degrees C / 82 degrees F
SFB 7 Inlet1	OK	29 degrees C / 84 degrees F
SFB 7 Exhaust2	OK	29 degrees C / 84 degrees F
SFB 7 SFB2-PF-local	OK	28 degrees C / 82 degrees F
SFB 7 SFB2-PF-die	OK	33 degrees C / 91 degrees F
FPC 0 Intake	OK	29 degrees C / 84 degrees F
FPC 0 Exhaust A	OK	42 degrees C / 107 degrees F

FPC 0 Exhaust B	OK	42 degrees C / 107 degrees F
FPC 0 XL 0 TSen	OK	38 degrees C / 100 degrees F
FPC 0 XL 0 Chip	OK	53 degrees C / 127 degrees F
FPC 0 XL 0 XR2 0 TSen	OK	38 degrees C / 100 degrees F
FPC 0 XL 0 XR2 0 Chip	OK	59 degrees C / 138 degrees F
FPC 0 XL 0 XR2 1 TSen	OK	38 degrees C / 100 degrees F
FPC 0 XL 0 XR2 1 Chip	OK	59 degrees C / 138 degrees F
FPC 0 XL 1 TSen	OK	30 degrees C / 86 degrees F
FPC 0 XL 1 Chip	OK	42 degrees C / 107 degrees F
FPC 0 XL 1 XR2 0 TSen	OK	30 degrees C / 86 degrees F
FPC 0 XL 1 XR2 0 Chip	OK	49 degrees C / 120 degrees F
FPC 0 XL 1 XR2 1 TSen	OK	30 degrees C / 86 degrees F
FPC 0 XL 1 XR2 1 Chip	OK	50 degrees C / 122 degrees F
FPC 0 XM 0 TSen	OK	42 degrees C / 107 degrees F
FPC 0 XM 0 Chip	OK	49 degrees C / 120 degrees F
FPC 0 XM 1 TSen	OK	42 degrees C / 107 degrees F
FPC 0 XM 1 Chip	OK	42 degrees C / 107 degrees F
FPC 0 XM 2 TSen	OK	42 degrees C / 107 degrees F
FPC 0 XM 2 Chip	OK	42 degrees C / 107 degrees F
FPC 0 XM 3 TSen	OK	42 degrees C / 107 degrees F
FPC 0 XM 3 Chip	OK	40 degrees C / 104 degrees F
FPC 0 PCIe Switch TSen	OK	42 degrees C / 107 degrees F
FPC 0 PCIe Switch Chip	OK	22 degrees C / 71 degrees F
FPC 1 Intake	OK	29 degrees C / 84 degrees F
FPC 1 Exhaust A	OK	52 degrees C / 125 degrees F
FPC 1 Exhaust B	OK	44 degrees C / 111 degrees F
FPC 1 EA0 TSen	OK	54 degrees C / 129 degrees F
FPC 1 EA0 Chip	OK	47 degrees C / 116 degrees F
FPC 1 EA0_XR0 TSen	OK	54 degrees C / 129 degrees F
FPC 1 EA0_XR0 Chip	OK	56 degrees C / 132 degrees F
FPC 1 EA0_XR1 TSen	OK	54 degrees C / 129 degrees F
FPC 1 EA0_XR1 Chip	OK	53 degrees C / 127 degrees F
FPC 1 EA1 TSen	OK	54 degrees C / 129 degrees F
FPC 1 EA1 Chip	OK	49 degrees C / 120 degrees F
FPC 1 EA1_XR0 TSen	OK	54 degrees C / 129 degrees F
FPC 1 EA1_XR0 Chip	OK	57 degrees C / 134 degrees F
FPC 1 EA1_XR1 TSen	OK	54 degrees C / 129 degrees F
FPC 1 EA1_XR1 Chip	OK	58 degrees C / 136 degrees F
FPC 1 PEX TSen	OK	54 degrees C / 129 degrees F
FPC 1 PEX Chip	OK	39 degrees C / 102 degrees F
FPC 1 EA2 TSen	OK	43 degrees C / 109 degrees F
FPC 1 EA2 Chip	OK	39 degrees C / 102 degrees F
FPC 1 EA2_XR0 TSen	OK	43 degrees C / 109 degrees F

FPC 1 EA2_XR0 Chip	OK	45 degrees C / 113 degrees F
FPC 1 EA2_XR1 TSen	OK	43 degrees C / 109 degrees F
FPC 1 EA2_XR1 Chip	OK	42 degrees C / 107 degrees F
FPC 1 EA3 TSen	OK	43 degrees C / 109 degrees F
FPC 1 EA3 Chip	OK	40 degrees C / 104 degrees F
FPC 1 EA3_XR0 TSen	OK	43 degrees C / 109 degrees F
FPC 1 EA3_XR0 Chip	OK	50 degrees C / 122 degrees F
FPC 1 EA3_XR1 TSen	OK	43 degrees C / 109 degrees F
FPC 1 EA3_XR1 Chip	OK	46 degrees C / 114 degrees F
FPC 1 EA0_HMC0 Logic die	OK	60 degrees C / 140 degrees F
FPC 1 EA0_HMC0 DRAM botm	OK	57 degrees C / 134 degrees F
FPC 1 EA0_HMC1 Logic die	OK	61 degrees C / 141 degrees F
FPC 1 EA0_HMC1 DRAM botm	OK	58 degrees C / 136 degrees F
FPC 1 EA0_HMC2 Logic die	OK	57 degrees C / 134 degrees F
FPC 1 EA0_HMC2 DRAM botm	OK	54 degrees C / 129 degrees F
FPC 1 EA1_HMC0 Logic die	OK	65 degrees C / 149 degrees F
FPC 1 EA1_HMC0 DRAM botm	OK	62 degrees C / 143 degrees F
FPC 1 EA1_HMC1 Logic die	OK	64 degrees C / 147 degrees F
FPC 1 EA1_HMC1 DRAM botm	OK	61 degrees C / 141 degrees F
FPC 1 EA1_HMC2 Logic die	OK	61 degrees C / 141 degrees F
FPC 1 EA1_HMC2 DRAM botm	OK	58 degrees C / 136 degrees F
FPC 1 EA2_HMC0 Logic die	OK	50 degrees C / 122 degrees F
FPC 1 EA2_HMC0 DRAM botm	OK	47 degrees C / 116 degrees F
FPC 1 EA2_HMC1 Logic die	OK	54 degrees C / 129 degrees F
FPC 1 EA2_HMC1 DRAM botm	OK	51 degrees C / 123 degrees F
FPC 1 EA2_HMC2 Logic die	OK	51 degrees C / 123 degrees F
FPC 1 EA2_HMC2 DRAM botm	OK	48 degrees C / 118 degrees F
FPC 1 EA3_HMC0 Logic die	OK	51 degrees C / 123 degrees F
FPC 1 EA3_HMC0 DRAM botm	OK	48 degrees C / 118 degrees F
FPC 1 EA3_HMC1 Logic die	OK	51 degrees C / 123 degrees F
FPC 1 EA3_HMC1 DRAM botm	OK	48 degrees C / 118 degrees F
FPC 1 EA3_HMC2 Logic die	OK	51 degrees C / 123 degrees F
FPC 1 EA3_HMC2 DRAM botm	OK	48 degrees C / 118 degrees F
FPC 7 Intake	OK	30 degrees C / 86 degrees F
FPC 7 Exhaust A	OK	45 degrees C / 113 degrees F
FPC 7 Exhaust B	OK	38 degrees C / 100 degrees F
FPC 7 QX 0 TSen	OK	48 degrees C / 118 degrees F
FPC 7 QX 0 Chip	OK	51 degrees C / 123 degrees F
FPC 7 LU 0 TCAM TSen	OK	48 degrees C / 118 degrees F
FPC 7 LU 0 TCAM Chip	OK	51 degrees C / 123 degrees F
FPC 7 LU 0 TSen	OK	48 degrees C / 118 degrees F
FPC 7 LU 0 Chip	OK	50 degrees C / 122 degrees F
FPC 7 MQ 0 TSen	OK	48 degrees C / 118 degrees F

FPC 7 MQ 0 Chip	OK	54 degrees C / 129 degrees F
FPC 7 QX 1 TSen	OK	41 degrees C / 105 degrees F
FPC 7 QX 1 Chip	OK	42 degrees C / 107 degrees F
FPC 7 LU 1 TCAM TSen	OK	41 degrees C / 105 degrees F
FPC 7 LU 1 TCAM Chip	OK	43 degrees C / 109 degrees F
FPC 7 LU 1 TSen	OK	41 degrees C / 105 degrees F
FPC 7 LU 1 Chip	OK	46 degrees C / 114 degrees F
FPC 7 MQ 1 TSen	OK	41 degrees C / 105 degrees F
FPC 7 MQ 1 Chip	OK	47 degrees C / 116 degrees F
ADC 7 Intake	OK	32 degrees C / 89 degrees F
ADC 7 Exhaust	OK	39 degrees C / 102 degrees F
ADC 7 ADC-XF1	OK	46 degrees C / 114 degrees F
ADC 7 ADC-XF0	OK	54 degrees C / 129 degrees F
Fans Fan Tray 0 Fan 1	OK	6240 RPM
Fan Tray 0 Fan 2	OK	6120 RPM
Fan Tray 0 Fan 3	OK	6120 RPM
Fan Tray 0 Fan 4	OK	5760 RPM
Fan Tray 0 Fan 5	OK	5880 RPM
Fan Tray 0 Fan 6	OK	6000 RPM
Fan Tray 1 Fan 1	OK	5880 RPM
Fan Tray 1 Fan 2	OK	5880 RPM
Fan Tray 1 Fan 3	OK	6000 RPM
Fan Tray 1 Fan 4	OK	6000 RPM
Fan Tray 1 Fan 5	OK	6000 RPM
Fan Tray 1 Fan 6	OK	6000 RPM

show chassis environment (T320 Router)

```

user@host> show chassis environment
Class Item          Status      Measurement
Power PEM 0         OK
    PEM 1          Absent
Temp SCG 0           OK          28 degrees C / 82 degrees F
    SCG 1           OK          28 degrees C / 82 degrees F
    Routing Engine 0 OK          31 degrees C / 87 degrees F
    Routing Engine 1 OK          30 degrees C / 86 degrees F
    CB 0            OK          32 degrees C / 89 degrees F
    CB 1            OK          32 degrees C / 89 degrees F
    SIB 0           OK          33 degrees C / 91 degrees F
    SIB 1           OK          33 degrees C / 91 degrees F
    SIB 2           OK          34 degrees C / 93 degrees F

```

```

FPC 0 Top          OK          38 degrees C / 100 degrees F
FPC 0 Bottom       OK          32 degrees C / 89 degrees F
FPC 1 Top          OK          38 degrees C / 100 degrees F
FPC 1 Bottom       OK          33 degrees C / 91 degrees F
FPC 2 Top          OK          36 degrees C / 96 degrees F
FPC 2 Bottom       OK          31 degrees C / 87 degrees F
FPM GBUS           OK          26 degrees C / 78 degrees F
FPM Display        OK          29 degrees C / 84 degrees F
Fans Top Left Front fan OK          Spinning at normal speed
Top Left Middle fan OK          Spinning at normal speed
Top Left Rear fan  OK          Spinning at normal speed
Top Right Front fan OK          Spinning at normal speed
Top Right Middle fan OK         Spinning at normal speed
Top Right Rear fan OK          Spinning at normal speed
Bottom Left Front fan OK        Spinning at normal speed
Bottom Left Middle fan OK       Spinning at normal speed
Bottom Left Rear fan OK         Spinning at normal speed
Bottom Right Front fan OK       Spinning at normal speed
Bottom Right Middle fan OK      Spinning at normal speed
Bottom Right Rear fan OK        Spinning at normal speed
Rear Tray Top fan  OK          Spinning at normal speed
Rear Tray Second fan OK         Spinning at normal speed
Rear Tray Middle fan OK         Spinning at normal speed
Rear Tray Fourth fan OK         Spinning at normal speed
Rear Tray Bottom fan OK         Spinning at normal speed
Misc CIP           OK
SPMB 0             OK
SPMB 1             OK

```

show chassis environment (MX10003 Router)

```
user@host> show chassis environment
```

```

Class Item                Status      Measurement
Temp CB 0 Exhaust Temp Sensor 0x49 OK          36 degrees C / 96 degrees F
      CB 0 Inlet Temp Sensor 0x49 OK          29 degrees C / 84 degrees F
      CB 1 Exhaust Temp Sensor 0x49 OK          36 degrees C / 96 degrees F
      CB 1 Inlet Temp Sensor 0x49 OK          31 degrees C / 87 degrees F
      FPC 0 Intake Temp Sensor OK          29 degrees C / 84 degrees F
      FPC 0 Exhaust-A Temp Sensor OK          55 degrees C / 131 degrees F

```

FPC 0 Exhaust-B Temp Sensor	OK	44 degrees C / 111 degrees F
FPC 0 EA0 Chip	OK	58 degrees C / 136 degrees F
FPC 0 EA0-XR0 Chip	OK	61 degrees C / 141 degrees F
FPC 0 EA0-XR1 Chip	OK	62 degrees C / 143 degrees F
FPC 0 EA1 Chip	OK	67 degrees C / 152 degrees F
FPC 0 EA1-XR0 Chip	OK	71 degrees C / 159 degrees F
FPC 0 EA1-XR1 Chip	OK	72 degrees C / 161 degrees F
FPC 0 PEX Chip	OK	75 degrees C / 167 degrees F
FPC 0 EA2 Chip	OK	49 degrees C / 120 degrees F
FPC 0 EA2-XR0 Chip	OK	55 degrees C / 131 degrees F
FPC 0 EA2-XR1 Chip	OK	56 degrees C / 132 degrees F
FPC 0 PF Chip	OK	68 degrees C / 154 degrees F
FPC 0 EA0_HMC0 Logic die	OK	72 degrees C / 161 degrees F
FPC 0 EA0_HMC0 DRAM botm	OK	69 degrees C / 156 degrees F
FPC 0 EA0_HMC1 Logic die	OK	72 degrees C / 161 degrees F
FPC 0 EA0_HMC1 DRAM botm	OK	69 degrees C / 156 degrees F
FPC 0 EA0_HMC2 Logic die	OK	75 degrees C / 167 degrees F
FPC 0 EA0_HMC2 DRAM botm	OK	72 degrees C / 161 degrees F
FPC 0 EA1_HMC0 Logic die	OK	81 degrees C / 177 degrees F
FPC 0 EA1_HMC0 DRAM botm	OK	78 degrees C / 172 degrees F
FPC 0 EA1_HMC1 Logic die	OK	79 degrees C / 174 degrees F
FPC 0 EA1_HMC1 DRAM botm	OK	76 degrees C / 168 degrees F
FPC 0 EA1_HMC2 Logic die	OK	82 degrees C / 179 degrees F
FPC 0 EA1_HMC2 DRAM botm	OK	79 degrees C / 174 degrees F
FPC 0 EA2_HMC0 Logic die	OK	61 degrees C / 141 degrees F
FPC 0 EA2_HMC0 DRAM botm	OK	58 degrees C / 136 degrees F
FPC 0 EA2_HMC1 Logic die	OK	62 degrees C / 143 degrees F
FPC 0 EA2_HMC1 DRAM botm	OK	59 degrees C / 138 degrees F
FPC 0 EA2_HMC2 Logic die	OK	64 degrees C / 147 degrees F
FPC 0 EA2_HMC2 DRAM botm	OK	61 degrees C / 141 degrees F
FPC 1 Intake Temp Sensor	OK	28 degrees C / 82 degrees F
FPC 1 Exhaust-A Temp Sensor	OK	58 degrees C / 136 degrees F
FPC 1 Exhaust-B Temp Sensor	OK	46 degrees C / 114 degrees F
FPC 1 EA0 Chip	OK	64 degrees C / 147 degrees F
FPC 1 EA0-XR0 Chip	OK	67 degrees C / 152 degrees F
FPC 1 EA0-XR1 Chip	OK	68 degrees C / 154 degrees F
FPC 1 EA1 Chip	OK	70 degrees C / 158 degrees F
FPC 1 EA1-XR0 Chip	OK	74 degrees C / 165 degrees F
FPC 1 EA1-XR1 Chip	OK	74 degrees C / 165 degrees F
FPC 1 PEX Chip	OK	88 degrees C / 190 degrees F
FPC 1 EA2 Chip	OK	50 degrees C / 122 degrees F
FPC 1 EA2-XR0 Chip	OK	54 degrees C / 129 degrees F
FPC 1 EA2-XR1 Chip	OK	56 degrees C / 132 degrees F

	FPC 1 PF Chip	OK	71 degrees C / 159 degrees F
	FPC 1 EA0_HMC0 Logic die	OK	74 degrees C / 165 degrees F
	FPC 1 EA0_HMC0 DRAM botm	OK	71 degrees C / 159 degrees F
	FPC 1 EA0_HMC1 Logic die	OK	78 degrees C / 172 degrees F
	FPC 1 EA0_HMC1 DRAM botm	OK	75 degrees C / 167 degrees F
	FPC 1 EA0_HMC2 Logic die	OK	78 degrees C / 172 degrees F
	FPC 1 EA0_HMC2 DRAM botm	OK	75 degrees C / 167 degrees F
	FPC 1 EA1_HMC0 Logic die	OK	84 degrees C / 183 degrees F
	FPC 1 EA1_HMC0 DRAM botm	OK	81 degrees C / 177 degrees F
	FPC 1 EA1_HMC1 Logic die	OK	81 degrees C / 177 degrees F
	FPC 1 EA1_HMC1 DRAM botm	OK	78 degrees C / 172 degrees F
	FPC 1 EA1_HMC2 Logic die	OK	85 degrees C / 185 degrees F
	FPC 1 EA1_HMC2 DRAM botm	OK	82 degrees C / 179 degrees F
	FPC 1 EA2_HMC0 Logic die	OK	63 degrees C / 145 degrees F
	FPC 1 EA2_HMC0 DRAM botm	OK	60 degrees C / 140 degrees F
	FPC 1 EA2_HMC1 Logic die	OK	60 degrees C / 140 degrees F
	FPC 1 EA2_HMC1 DRAM botm	OK	57 degrees C / 134 degrees F
	FPC 1 EA2_HMC2 Logic die	OK	66 degrees C / 150 degrees F
	FPC 1 EA2_HMC2 DRAM botm	OK	63 degrees C / 145 degrees F
Power	PEM 0	OK	
	PEM 1	OK	
	PEM 2	OK	
	PEM 3	OK	
	PEM 4	Absent	
	PEM 5	Absent	
Fans	Fan Tray 0 Fan 0	OK	Spinning at normal speed
	Fan Tray 0 Fan 1	OK	Spinning at normal speed
	Fan Tray 0 Fan 2	OK	Spinning at normal speed
	Fan Tray 0 Fan 3	OK	Spinning at normal speed
	Fan Tray 1 Fan 0	OK	Spinning at normal speed
	Fan Tray 1 Fan 1	OK	Spinning at normal speed
	Fan Tray 1 Fan 2	OK	Spinning at normal speed
	Fan Tray 1 Fan 3	OK	Spinning at normal speed
	Fan Tray 2 Fan 0	OK	Spinning at normal speed
	Fan Tray 2 Fan 1	OK	Spinning at normal speed
	Fan Tray 2 Fan 2	OK	Spinning at normal speed
	Fan Tray 2 Fan 3	OK	Spinning at normal speed
	Fan Tray 3 Fan 0	OK	Spinning at normal speed
	Fan Tray 3 Fan 1	OK	Spinning at normal speed
	Fan Tray 3 Fan 2	OK	Spinning at normal speed
	Fan Tray 3 Fan 3	OK	Spinning at normal speed

show chassis environment (MX10008 Router)

```
user@host> show chassis environment
```

Class	Item	Status	Measurement
	Routing Engine 0 CPU	OK	41 degrees C / 105 degrees F
	Routing Engine 1 CPU	OK	40 degrees C / 104 degrees F
Temp	CB 0 Intake A Temp Sensor	OK	24 degrees C / 75 degrees F
	CB 0 Intake B Temp Sensor	OK	24 degrees C / 75 degrees F
	CB 0 Exhaust A Temp Sensor	OK	28 degrees C / 82 degrees F
	CB 0 Exhaust B Temp Sensor	OK	30 degrees C / 86 degrees F
	CB 0 Middle Temp Sensor	OK	28 degrees C / 82 degrees F
	CB 1 Intake A Temp Sensor	OK	24 degrees C / 75 degrees F
	CB 1 Intake B Temp Sensor	OK	23 degrees C / 73 degrees F
	CB 1 Exhaust A Temp Sensor	OK	27 degrees C / 80 degrees F
	CB 1 Exhaust B Temp Sensor	OK	29 degrees C / 84 degrees F
	CB 1 Middle Temp Sensor	OK	28 degrees C / 82 degrees F
	FPC 0 Intake-A Temp Sensor	OK	32 degrees C / 89 degrees F
	FPC 0 Exhaust-A Temp Sensor	OK	44 degrees C / 111 degrees F
	FPC 0 Exhaust-B Temp Sensor	OK	49 degrees C / 120 degrees F
	FPC 0 EA0 Temp Sensor	OK	66 degrees C / 150 degrees F
	FPC 0 EA0_XR0 Temp Sensor	OK	69 degrees C / 156 degrees F
	FPC 0 EA0_XR1 Temp Sensor	OK	73 degrees C / 163 degrees F
	FPC 0 EA1 Temp Sensor	OK	60 degrees C / 140 degrees F
	FPC 0 EA1_XR0 Temp Sensor	OK	64 degrees C / 147 degrees F
	FPC 0 EA1_XR1 Temp Sensor	OK	63 degrees C / 145 degrees F
	FPC 0 EA2 Temp Sensor	OK	68 degrees C / 154 degrees F
	FPC 0 EA2_XR0 Temp Sensor	OK	73 degrees C / 163 degrees F
	FPC 0 EA2_XR1 Temp Sensor	OK	72 degrees C / 161 degrees F
	FPC 0 EA3 Temp Sensor	OK	63 degrees C / 145 degrees F
	FPC 0 EA3_XR0 Temp Sensor	OK	66 degrees C / 150 degrees F
	FPC 0 EA3_XR1 Temp Sensor	OK	65 degrees C / 149 degrees F
	FPC 0 EA4 Temp Sensor	OK	68 degrees C / 154 degrees F
	FPC 0 EA4_XR0 Temp Sensor	OK	71 degrees C / 159 degrees F
	FPC 0 EA4_XR1 Temp Sensor	OK	70 degrees C / 158 degrees F
	FPC 0 EA5 Temp Sensor	OK	56 degrees C / 132 degrees F
	FPC 0 EA5_XR0 Temp Sensor	OK	61 degrees C / 141 degrees F
	FPC 0 EA5_XR1 Temp Sensor	OK	63 degrees C / 145 degrees F
	FPC 0 EA0_HMC0 Logic die	OK	75 degrees C / 167 degrees F
	FPC 0 EA0_HMC0 DRAM botm	OK	72 degrees C / 161 degrees F
	FPC 0 EA0_HMC1 Logic die	OK	75 degrees C / 167 degrees F
	FPC 0 EA0_HMC1 DRAM botm	OK	72 degrees C / 161 degrees F
	FPC 0 EA0_HMC2 Logic die	OK	77 degrees C / 170 degrees F

FPC 0 EA0_HMC2 DRAM botm	OK	74 degrees C / 165 degrees F
FPC 0 EA1_HMC0 Logic die	OK	72 degrees C / 161 degrees F
FPC 0 EA1_HMC0 DRAM botm	OK	69 degrees C / 156 degrees F
FPC 0 EA1_HMC1 Logic die	OK	73 degrees C / 163 degrees F
FPC 0 EA1_HMC1 DRAM botm	OK	70 degrees C / 158 degrees F
FPC 0 EA1_HMC2 Logic die	OK	72 degrees C / 161 degrees F
FPC 0 EA1_HMC2 DRAM botm	OK	69 degrees C / 156 degrees F
FPC 0 EA2_HMC0 Logic die	OK	80 degrees C / 176 degrees F
FPC 0 EA2_HMC0 DRAM botm	OK	77 degrees C / 170 degrees F
FPC 0 EA2_HMC1 Logic die	OK	80 degrees C / 176 degrees F
FPC 0 EA2_HMC1 DRAM botm	OK	77 degrees C / 170 degrees F
FPC 0 EA2_HMC2 Logic die	OK	79 degrees C / 174 degrees F
FPC 0 EA2_HMC2 DRAM botm	OK	76 degrees C / 168 degrees F
FPC 0 EA3_HMC0 Logic die	OK	77 degrees C / 170 degrees F
FPC 0 EA3_HMC0 DRAM botm	OK	74 degrees C / 165 degrees F
FPC 0 EA3_HMC1 Logic die	OK	78 degrees C / 172 degrees F
FPC 0 EA3_HMC1 DRAM botm	OK	75 degrees C / 167 degrees F
FPC 0 EA3_HMC2 Logic die	OK	77 degrees C / 170 degrees F
FPC 0 EA3_HMC2 DRAM botm	OK	74 degrees C / 165 degrees F
FPC 0 EA4_HMC0 Logic die	OK	80 degrees C / 176 degrees F
FPC 0 EA4_HMC0 DRAM botm	OK	77 degrees C / 170 degrees F
FPC 0 EA4_HMC1 Logic die	OK	81 degrees C / 177 degrees F
FPC 0 EA4_HMC1 DRAM botm	OK	78 degrees C / 172 degrees F
FPC 0 EA4_HMC2 Logic die	OK	80 degrees C / 176 degrees F
FPC 0 EA4_HMC2 DRAM botm	OK	77 degrees C / 170 degrees F
FPC 0 EA5_HMC0 Logic die	OK	68 degrees C / 154 degrees F
FPC 0 EA5_HMC0 DRAM botm	OK	65 degrees C / 149 degrees F
FPC 0 EA5_HMC1 Logic die	OK	68 degrees C / 154 degrees F
FPC 0 EA5_HMC1 DRAM botm	OK	65 degrees C / 149 degrees F
FPC 0 EA5_HMC2 Logic die	OK	67 degrees C / 152 degrees F
FPC 0 EA5_HMC2 DRAM botm	OK	64 degrees C / 147 degrees F
FPC 2 Intake-A Temp Sensor	OK	32 degrees C / 89 degrees F
FPC 2 Exhaust-A Temp Sensor	OK	52 degrees C / 125 degrees F
FPC 2 Exhaust-B Temp Sensor	OK	50 degrees C / 122 degrees F
FPC 2 EA0 Temp Sensor	OK	71 degrees C / 159 degrees F
FPC 2 EA0_XR0 Temp Sensor	OK	75 degrees C / 167 degrees F
FPC 2 EA0_XR1 Temp Sensor	OK	78 degrees C / 172 degrees F
FPC 2 EA1 Temp Sensor	OK	64 degrees C / 147 degrees F
FPC 2 EA1_XR0 Temp Sensor	OK	67 degrees C / 152 degrees F
FPC 2 EA1_XR1 Temp Sensor	OK	65 degrees C / 149 degrees F
FPC 2 EA2 Temp Sensor	OK	75 degrees C / 167 degrees F
FPC 2 EA2_XR0 Temp Sensor	OK	80 degrees C / 176 degrees F
FPC 2 EA2_XR1 Temp Sensor	OK	80 degrees C / 176 degrees F

FPC 2 EA3 Temp Sensor	OK	66 degrees C / 150 degrees F
FPC 2 EA3_XR0 Temp Sensor	OK	69 degrees C / 156 degrees F
FPC 2 EA3_XR1 Temp Sensor	OK	69 degrees C / 156 degrees F
FPC 2 EA4 Temp Sensor	OK	75 degrees C / 167 degrees F
FPC 2 EA4_XR0 Temp Sensor	OK	76 degrees C / 168 degrees F
FPC 2 EA4_XR1 Temp Sensor	OK	75 degrees C / 167 degrees F
FPC 2 EA5 Temp Sensor	OK	60 degrees C / 140 degrees F
FPC 2 EA5_XR0 Temp Sensor	OK	64 degrees C / 147 degrees F
FPC 2 EA5_XR1 Temp Sensor	OK	64 degrees C / 147 degrees F
FPC 2 EA0_HMC0 Logic die	OK	84 degrees C / 183 degrees F
FPC 2 EA0_HMC0 DRAM botm	OK	81 degrees C / 177 degrees F
FPC 2 EA0_HMC1 Logic die	OK	85 degrees C / 185 degrees F
FPC 2 EA0_HMC1 DRAM botm	OK	82 degrees C / 179 degrees F
FPC 2 EA0_HMC2 Logic die	OK	83 degrees C / 181 degrees F
FPC 2 EA0_HMC2 DRAM botm	OK	80 degrees C / 176 degrees F
FPC 2 EA1_HMC0 Logic die	OK	76 degrees C / 168 degrees F
FPC 2 EA1_HMC0 DRAM botm	OK	73 degrees C / 163 degrees F
FPC 2 EA1_HMC1 Logic die	OK	76 degrees C / 168 degrees F
FPC 2 EA1_HMC1 DRAM botm	OK	73 degrees C / 163 degrees F
FPC 2 EA1_HMC2 Logic die	OK	76 degrees C / 168 degrees F
FPC 2 EA1_HMC2 DRAM botm	OK	73 degrees C / 163 degrees F
FPC 2 EA2_HMC0 Logic die	OK	86 degrees C / 186 degrees F
FPC 2 EA2_HMC0 DRAM botm	OK	83 degrees C / 181 degrees F
FPC 2 EA2_HMC1 Logic die	OK	87 degrees C / 188 degrees F
FPC 2 EA2_HMC1 DRAM botm	OK	84 degrees C / 183 degrees F
FPC 2 EA2_HMC2 Logic die	OK	87 degrees C / 188 degrees F
FPC 2 EA2_HMC2 DRAM botm	OK	84 degrees C / 183 degrees F
FPC 2 EA3_HMC0 Logic die	OK	80 degrees C / 176 degrees F
FPC 2 EA3_HMC0 DRAM botm	OK	77 degrees C / 170 degrees F
FPC 2 EA3_HMC1 Logic die	OK	80 degrees C / 176 degrees F
FPC 2 EA3_HMC1 DRAM botm	OK	77 degrees C / 170 degrees F
FPC 2 EA3_HMC2 Logic die	OK	80 degrees C / 176 degrees F
FPC 2 EA3_HMC2 DRAM botm	OK	77 degrees C / 170 degrees F
FPC 2 EA4_HMC0 Logic die	OK	88 degrees C / 190 degrees F
FPC 2 EA4_HMC0 DRAM botm	OK	85 degrees C / 185 degrees F
FPC 2 EA4_HMC1 Logic die	OK	89 degrees C / 192 degrees F
FPC 2 EA4_HMC1 DRAM botm	OK	86 degrees C / 186 degrees F
FPC 2 EA4_HMC2 Logic die	OK	80 degrees C / 176 degrees F
FPC 2 EA4_HMC2 DRAM botm	OK	77 degrees C / 170 degrees F
FPC 2 EA5_HMC0 Logic die	OK	72 degrees C / 161 degrees F
FPC 2 EA5_HMC0 DRAM botm	OK	69 degrees C / 156 degrees F
FPC 2 EA5_HMC1 Logic die	OK	69 degrees C / 156 degrees F
FPC 2 EA5_HMC1 DRAM botm	OK	66 degrees C / 150 degrees F

FPC 2 EA5_HMC2 Logic die	OK	72 degrees C / 161 degrees F
FPC 2 EA5_HMC2 DRAM botm	OK	69 degrees C / 156 degrees F
FPC 3 Intake-A Temp Sensor	OK	30 degrees C / 86 degrees F
FPC 3 Exhaust-A Temp Sensor	OK	48 degrees C / 118 degrees F
FPC 3 Exhaust-B Temp Sensor	OK	44 degrees C / 111 degrees F
FPC 3 EA0 Temp Sensor	OK	60 degrees C / 140 degrees F
FPC 3 EA0_XR0 Temp Sensor	OK	65 degrees C / 149 degrees F
FPC 3 EA0_XR1 Temp Sensor	OK	67 degrees C / 152 degrees F
FPC 3 EA1 Temp Sensor	OK	54 degrees C / 129 degrees F
FPC 3 EA1_XR0 Temp Sensor	OK	59 degrees C / 138 degrees F
FPC 3 EA1_XR1 Temp Sensor	OK	58 degrees C / 136 degrees F
FPC 3 EA2 Temp Sensor	OK	62 degrees C / 143 degrees F
FPC 3 EA2_XR0 Temp Sensor	OK	66 degrees C / 150 degrees F
FPC 3 EA2_XR1 Temp Sensor	OK	66 degrees C / 150 degrees F
FPC 3 EA3 Temp Sensor	OK	54 degrees C / 129 degrees F
FPC 3 EA3_XR0 Temp Sensor	OK	57 degrees C / 134 degrees F
FPC 3 EA3_XR1 Temp Sensor	OK	56 degrees C / 132 degrees F
FPC 3 EA4 Temp Sensor	OK	68 degrees C / 154 degrees F
FPC 3 EA4_XR0 Temp Sensor	OK	71 degrees C / 159 degrees F
FPC 3 EA4_XR1 Temp Sensor	OK	70 degrees C / 158 degrees F
FPC 3 EA5 Temp Sensor	OK	55 degrees C / 131 degrees F
FPC 3 EA5_XR0 Temp Sensor	OK	58 degrees C / 136 degrees F
FPC 3 EA5_XR1 Temp Sensor	OK	58 degrees C / 136 degrees F
FPC 3 EA0_HMC0 Logic die	OK	69 degrees C / 156 degrees F
FPC 3 EA0_HMC0 DRAM botm	OK	66 degrees C / 150 degrees F
FPC 3 EA0_HMC1 Logic die	OK	70 degrees C / 158 degrees F
FPC 3 EA0_HMC1 DRAM botm	OK	67 degrees C / 152 degrees F
FPC 3 EA0_HMC2 Logic die	OK	69 degrees C / 156 degrees F
FPC 3 EA0_HMC2 DRAM botm	OK	66 degrees C / 150 degrees F
FPC 3 EA1_HMC0 Logic die	OK	67 degrees C / 152 degrees F
FPC 3 EA1_HMC0 DRAM botm	OK	64 degrees C / 147 degrees F
FPC 3 EA1_HMC1 Logic die	OK	64 degrees C / 147 degrees F
FPC 3 EA1_HMC1 DRAM botm	OK	61 degrees C / 141 degrees F
FPC 3 EA1_HMC2 Logic die	OK	64 degrees C / 147 degrees F
FPC 3 EA1_HMC2 DRAM botm	OK	61 degrees C / 141 degrees F
FPC 3 EA2_HMC0 Logic die	OK	74 degrees C / 165 degrees F
FPC 3 EA2_HMC0 DRAM botm	OK	71 degrees C / 159 degrees F
FPC 3 EA2_HMC1 Logic die	OK	76 degrees C / 168 degrees F
FPC 3 EA2_HMC1 DRAM botm	OK	73 degrees C / 163 degrees F
FPC 3 EA2_HMC2 Logic die	OK	74 degrees C / 165 degrees F
FPC 3 EA2_HMC2 DRAM botm	OK	71 degrees C / 159 degrees F
FPC 3 EA3_HMC0 Logic die	OK	69 degrees C / 156 degrees F
FPC 3 EA3_HMC0 DRAM botm	OK	66 degrees C / 150 degrees F

FPC 3 EA3_HMC1 Logic die	OK	68 degrees C / 154 degrees F
FPC 3 EA3_HMC1 DRAM botm	OK	65 degrees C / 149 degrees F
FPC 3 EA3_HMC2 Logic die	OK	68 degrees C / 154 degrees F
FPC 3 EA3_HMC2 DRAM botm	OK	65 degrees C / 149 degrees F
FPC 3 EA4_HMC0 Logic die	OK	81 degrees C / 177 degrees F
FPC 3 EA4_HMC0 DRAM botm	OK	78 degrees C / 172 degrees F
FPC 3 EA4_HMC1 Logic die	OK	80 degrees C / 176 degrees F
FPC 3 EA4_HMC1 DRAM botm	OK	77 degrees C / 170 degrees F
FPC 3 EA4_HMC2 Logic die	OK	81 degrees C / 177 degrees F
FPC 3 EA4_HMC2 DRAM botm	OK	78 degrees C / 172 degrees F
FPC 3 EA5_HMC0 Logic die	OK	68 degrees C / 154 degrees F
FPC 3 EA5_HMC0 DRAM botm	OK	65 degrees C / 149 degrees F
FPC 3 EA5_HMC1 Logic die	OK	70 degrees C / 158 degrees F
FPC 3 EA5_HMC1 DRAM botm	OK	67 degrees C / 152 degrees F
FPC 3 EA5_HMC2 Logic die	OK	69 degrees C / 156 degrees F
FPC 3 EA5_HMC2 DRAM botm	OK	66 degrees C / 150 degrees F
Power PEM 0	OK	29 degrees C / 84 degrees F
PEM 1	OK	27 degrees C / 80 degrees F
PEM 2	OK	30 degrees C / 86 degrees F
PEM 3	Check	
PEM 4	Check	
PEM 5	Check	
Fans Fan Tray 0 Fan 0	OK	Spinning at normal speed
Fan Tray 0 Fan 1	OK	Spinning at normal speed
Fan Tray 0 Fan 2	OK	Spinning at normal speed
Fan Tray 0 Fan 3	OK	Spinning at normal speed
Fan Tray 0 Fan 4	Failed	
Fan Tray 0 Fan 5	Failed	
Fan Tray 0 Fan 6	OK	Spinning at normal speed
Fan Tray 0 Fan 7	OK	Spinning at normal speed
Fan Tray 0 Fan 8	OK	Spinning at normal speed
Fan Tray 0 Fan 9	OK	Spinning at normal speed
Fan Tray 0 Fan 10	OK	Spinning at normal speed
Fan Tray 1 Fan 0	OK	Spinning at normal speed
Fan Tray 1 Fan 1	OK	Spinning at normal speed
Fan Tray 1 Fan 2	OK	Spinning at normal speed
Fan Tray 1 Fan 3	OK	Spinning at normal speed
Fan Tray 1 Fan 4	OK	Spinning at normal speed
Fan Tray 1 Fan 5	OK	Spinning at normal speed
Fan Tray 1 Fan 6	OK	Spinning at normal speed
Fan Tray 1 Fan 7	OK	Spinning at normal speed
Fan Tray 1 Fan 8	OK	Spinning at normal speed
Fan Tray 1 Fan 9	OK	Spinning at normal speed

Fan Tray 1 Fan 10	OK	Spinning at normal speed
SFB 0 Intake-A	OK	32 degrees C / 89 degrees F
SFB 0 Intake-B	OK	21 degrees C / 69 degrees F
SFB 0 Exhaust-A	OK	27 degrees C / 80 degrees F
SFB 0 Exhaust-B	OK	32 degrees C / 89 degrees F
SFB 0 PF0	OK	39 degrees C / 102 degrees F
SFB 0 PF1	OK	29 degrees C / 84 degrees F
SFB 1 Intake-A	OK	43 degrees C / 109 degrees F
SFB 1 Intake-B	OK	20 degrees C / 68 degrees F
SFB 1 Exhaust-A	OK	25 degrees C / 77 degrees F
SFB 1 Exhaust-B	OK	44 degrees C / 111 degrees F
SFB 1 PF0	OK	50 degrees C / 122 degrees F
SFB 1 PF1	OK	29 degrees C / 84 degrees F
SFB 2 Intake-A	OK	39 degrees C / 102 degrees F
SFB 2 Intake-B	OK	20 degrees C / 68 degrees F
SFB 2 Exhaust-A	OK	25 degrees C / 77 degrees F
SFB 2 Exhaust-B	OK	38 degrees C / 100 degrees F
SFB 2 PF0	OK	45 degrees C / 113 degrees F
SFB 2 PF1	OK	30 degrees C / 86 degrees F
SFB 3 Intake-A	OK	36 degrees C / 96 degrees F
SFB 3 Intake-B	OK	20 degrees C / 68 degrees F
SFB 3 Exhaust-A	OK	25 degrees C / 77 degrees F
SFB 3 Exhaust-B	OK	35 degrees C / 95 degrees F
SFB 3 PF0	OK	42 degrees C / 107 degrees F
SFB 3 PF1	OK	29 degrees C / 84 degrees F
SFB 4 Intake-A	OK	30 degrees C / 86 degrees F
SFB 4 Intake-B	OK	20 degrees C / 68 degrees F
SFB 4 Exhaust-A	OK	25 degrees C / 77 degrees F
SFB 4 Exhaust-B	OK	31 degrees C / 87 degrees F
SFB 4 PF0	OK	41 degrees C / 105 degrees F
SFB 4 PF1	OK	29 degrees C / 84 degrees F
SFB 5 Intake-A	OK	30 degrees C / 86 degrees F
SFB 5 Intake-B	OK	21 degrees C / 69 degrees F
SFB 5 Exhaust-A	OK	25 degrees C / 77 degrees F
SFB 5 Exhaust-B	OK	30 degrees C / 86 degrees F
SFB 5 PF0	OK	35 degrees C / 95 degrees F
SFB 5 PF1	OK	34 degrees C / 93 degrees F

show chassis environment (MX204 Router)

```
user@host> show chassis environment
```

Class	Item	Status	Measurement
Temp	CB 0 Top Right Inlet Sensor	OK	35 degrees C / 95 degrees F
	CB 0 Top Left Inlet Sensor	OK	37 degrees C / 98 degrees F
	CB 0 Top Right Exhaust Sensor	OK	43 degrees C / 109 degrees F
	CB 0 Top Left Exhaust Sensor	OK	50 degrees C / 122 degrees F
	CB 0 CPU Core-0 Temp	OK	47 degrees C / 116 degrees F
	CB 0 CPU Core-1 Temp	OK	48 degrees C / 118 degrees F
	CB 0 CPU Core-2 Temp	OK	47 degrees C / 116 degrees F
	CB 0 CPU Core-3 Temp	OK	47 degrees C / 116 degrees F
	CB 0 CPU Core-4 Temp	OK	47 degrees C / 116 degrees F
	CB 0 CPU Core-5 Temp	OK	47 degrees C / 116 degrees F
	CB 0 CPU Core-6 Temp	OK	47 degrees C / 116 degrees F
	CB 0 CPU Core-7 Temp	OK	47 degrees C / 116 degrees F
	FPC 0 EA0_HMC0 Logic die	OK	77 degrees C / 170 degrees F
	FPC 0 EA0_HMC0 DRAM botm	OK	74 degrees C / 165 degrees F
	FPC 0 EA0_HMC1 Logic die	OK	81 degrees C / 177 degrees F
	FPC 0 EA0_HMC1 DRAM botm	OK	78 degrees C / 172 degrees F
	FPC 0 EA0 Chip	OK	94 degrees C / 201 degrees F
FPC 0 EA0-XR0 Chip	OK	64 degrees C / 147 degrees F	
FPC 0 EA0-XR1 Chip	OK	65 degrees C / 149 degrees F	
Power	PEM 0	Absent	
	PEM 1	OK	48 degrees C / 118 degrees F
Fans	Fan Tray 0 Fan 0	OK	Spinning at normal speed
	Fan Tray 0 Fan 1	OK	Spinning at normal speed
	Fan Tray 1 Fan 0	OK	Spinning at normal speed
	Fan Tray 1 Fan 1	OK	Spinning at normal speed
	Fan Tray 2 Fan 0	OK	Spinning at normal speed
	Fan Tray 2 Fan 1	OK	Spinning at normal speed

show chassis environment (T640 Router)

```
user@host> show chassis environment
```

Class	Item	Status	Measurement
Temp	PEM 0	Absent	
	PEM 1	OK	22 degrees C / 71 degrees F
	SCG 0	OK	30 degrees C / 86 degrees F

	SCG 1	OK	30 degrees C / 86 degrees F
	Routing Engine 0	Present	
	Routing Engine 1	OK	27 degrees C / 80 degrees F
	CB 0	Present	
	CB 1	OK	33 degrees C / 91 degrees F
	SIB 0	Absent	
	SIB 1	Absent	
	SIB 2	Absent	
	SIB 3	Absent	
	SIB 4	Absent	
	FPC 4 Top	Testing	
	FPC 4 Bottom	Testing	
	FPC 5 Top	Testing	
	FPC 5 Bottom	Testing	
	FPC 6 Top	Testing	
	FPC 6 Bottom	Testing	
	FPM GBUS	OK	23 degrees C / 73 degrees F
	FPM Display	Absent	
Fans	Top Left Front fan	OK	Spinning at normal speed
	Top Left Middle fan	OK	Spinning at normal speed
	Top Left Rear fan	OK	Spinning at normal speed
	Top Right Front fan	OK	Spinning at normal speed
	Top Right Middle fan	OK	Spinning at normal speed
	Top Right Rear fan	OK	Spinning at normal speed
	Bottom Left Front fan	OK	Spinning at normal speed
	Bottom Left Middle fan	OK	Spinning at normal speed
	Bottom Left Rear fan	OK	Spinning at normal speed
	Bottom Right Front fan	OK	Spinning at normal speed
	Bottom Right Middle fan	OK	Spinning at normal speed
	Bottom Right Rear fan	OK	Spinning at normal speed
	Fourth Blower from top	OK	Spinning at normal speed
	Bottom Blower	OK	Spinning at normal speed
	Middle Blower	OK	Spinning at normal speed
	Top Blower	OK	Spinning at normal speed
	Second Blower from top	OK	Spinning at normal speed
Misc	CIP	OK	
	SPMB 0	OK	
	SPMB 1	OK	

show chassis environment (T4000 Router)

```

user@host> show chassis environment
Class Item                               Status      Measurement
Temp PEM 0                               OK          33 degrees C / 91 degrees F
      PEM 1                               Absent
      SCG 0                               OK          33 degrees C / 91 degrees F
      SCG 1                               OK          33 degrees C / 91 degrees F
      Routing Engine 0                   OK          33 degrees C / 91 degrees F
      Routing Engine 0 CPU                OK          50 degrees C / 122 degrees F
      Routing Engine 1                   OK          32 degrees C / 89 degrees F
      Routing Engine 1 CPU                OK          46 degrees C / 114 degrees F
      CB 0                               OK          32 degrees C / 89 degrees F
      CB 1                               OK          33 degrees C / 91 degrees F
      SIB 0                               OK          42 degrees C / 107 degrees F
      SIB 1                               OK          42 degrees C / 107 degrees F
      SIB 2                               OK          42 degrees C / 107 degrees F
      SIB 3                               OK          43 degrees C / 109 degrees F
      SIB 4                               OK          45 degrees C / 113 degrees F
      FPC 0 Fan Intake                    OK          34 degrees C / 93 degrees F
      FPC 0 Fan Exhaust                    OK          48 degrees C / 118 degrees F
      FPC 0 PMB                           OK          47 degrees C / 116 degrees F
      FPC 0 LMB0                           OK          50 degrees C / 122 degrees F
      FPC 0 LMB1                           OK          41 degrees C / 105 degrees F
      FPC 0 LMB2                           OK          35 degrees C / 95 degrees F
      FPC 0 PFE1 LU2                       OK          46 degrees C / 114 degrees F
      FPC 0 PFE1 LU0                       OK          41 degrees C / 105 degrees F
      FPC 0 PFE0 LU0                       OK          57 degrees C / 134 degrees F
      FPC 0 XF1                             OK          46 degrees C / 114 degrees F
      FPC 0 XF0                             OK          52 degrees C / 125 degrees F
      FPC 0 XM1                             OK          41 degrees C / 105 degrees F
      FPC 0 XM0                             OK          50 degrees C / 122 degrees F
      FPC 0 PFE0 LU1                       OK          56 degrees C / 132 degrees F
      FPC 0 PFE0 LU2                       OK          45 degrees C / 113 degrees F
      FPC 0 PFE1 LU1                       OK          37 degrees C / 98 degrees F
      FPC 3 Fan Intake                     OK          36 degrees C / 96 degrees F
      FPC 3 Fan Exhaust                    OK          51 degrees C / 123 degrees F
      FPC 3 PMB                           OK          43 degrees C / 109 degrees F
      FPC 3 LMB0                           OK          57 degrees C / 134 degrees F
      FPC 3 LMB1                           OK          54 degrees C / 129 degrees F
      FPC 3 LMB2                           OK          38 degrees C / 100 degrees F
      FPC 3 PFE1 LU2                       OK          63 degrees C / 145 degrees F

```

FPC 3 PFE1 LU0	OK	45 degrees C / 113 degrees F
FPC 3 PFE0 LU0	OK	69 degrees C / 156 degrees F
FPC 3 XF1	OK	62 degrees C / 143 degrees F
FPC 3 XF0	OK	63 degrees C / 145 degrees F
FPC 3 XM1	OK	43 degrees C / 109 degrees F
FPC 3 XM0	OK	67 degrees C / 152 degrees F
FPC 3 PFE0 LU1	OK	63 degrees C / 145 degrees F
FPC 3 PFE0 LU2	OK	66 degrees C / 150 degrees F
FPC 3 PFE1 LU1	OK	41 degrees C / 105 degrees F
FPC 5 Top	OK	39 degrees C / 102 degrees F
FPC 5 Bottom	OK	38 degrees C / 100 degrees F
FPC 6 Fan Intake	OK	33 degrees C / 91 degrees F
FPC 6 Fan Exhaust	OK	49 degrees C / 120 degrees F
FPC 6 PMB	OK	40 degrees C / 104 degrees F
FPC 6 LMB0	OK	60 degrees C / 140 degrees F
FPC 6 LMB1	OK	58 degrees C / 136 degrees F
FPC 6 LMB2	OK	40 degrees C / 104 degrees F
FPC 6 PFE1 LU2	OK	69 degrees C / 156 degrees F
FPC 6 PFE1 LU0	OK	45 degrees C / 113 degrees F
FPC 6 PFE0 LU0	OK	71 degrees C / 159 degrees F
FPC 6 XF1	OK	58 degrees C / 136 degrees F
FPC 6 XF0	OK	65 degrees C / 149 degrees F
FPC 6 XM1	OK	39 degrees C / 102 degrees F
FPC 6 XM0	OK	66 degrees C / 150 degrees F
FPC 6 PFE0 LU1	OK	69 degrees C / 156 degrees F
FPC 6 PFE0 LU2	OK	69 degrees C / 156 degrees F
FPC 6 PFE1 LU1	OK	42 degrees C / 107 degrees F
FPM GBUS	OK	24 degrees C / 75 degrees F
FPM Display	OK	27 degrees C / 80 degrees F
Fans Top Left Front fan	OK	Spinning at high speed
Top Left Middle fan	OK	Spinning at high speed
Top Left Rear fan	OK	Spinning at high speed
Top Right Front fan	OK	Spinning at high speed
Top Right Middle fan	OK	Spinning at high speed
Top Right Rear fan	OK	Spinning at high speed
Bottom Left Front fan	OK	Spinning at high speed
Bottom Left Middle fan	OK	Spinning at high speed
Bottom Left Rear fan	OK	Spinning at high speed
Bottom Right Front fan	OK	Spinning at high speed
Bottom Right Middle fan	OK	Spinning at high speed
Bottom Right Rear fan	OK	Spinning at high speed
Rear Tray Top fan	OK	Spinning at high speed
Rear Tray Second fan	OK	Spinning at high speed

	Rear Tray Third fan	OK	Spinning at high speed
	Rear Tray Fourth fan	OK	Spinning at high speed
	Rear Tray Fifth fan	OK	Spinning at high speed
	Rear Tray Sixth fan	OK	Spinning at high speed
	Rear Tray Seventh fan	OK	Spinning at high speed
	Rear Tray Bottom fan	OK	Spinning at high speed
Misc	CIP	OK	
	SPMB 0	OK	
	SPMB 1	OK	

show chassis environment (TX Matrix Router)

```
user@host> show chassis environment
```

```
-----
Class Item                Status      Measurement
Temp PEM 0                Absent
    PEM 1                 OK         29 degrees C / 84 degrees F
    Routing Engine 0      OK         34 degrees C / 93 degrees F
    Routing Engine 1      OK         34 degrees C / 93 degrees F
    CB 0                  OK         32 degrees C / 89 degrees F
    CB 1                  OK         32 degrees C / 89 degrees F
    SIB 0                 OK         44 degrees C / 111 degrees F
    SIB 0 (B)             OK         44 degrees C / 111 degrees F
    FPM GBUS              OK         27 degrees C / 80 degrees F
    FPM Display           OK         32 degrees C / 89 degrees F
Fans Top Left Front fan    OK         Spinning at normal speed
    Top Left Middle fan   OK         Spinning at normal speed
    Top Left Rear fan     OK         Spinning at normal speed
    Top Right Front fan   OK         Spinning at normal speed
    Top Right Middle fan  OK         Spinning at normal speed
    Top Right Rear fan    OK         Spinning at normal speed
    Bottom Left Front fan OK         Spinning at normal speed
    Bottom Left Middle fan OK        Spinning at normal speed
    Bottom Left Rear fan  OK         Spinning at normal speed
    Bottom Right Front fan OK        Spinning at normal speed
    Bottom Right Middle fan OK       Spinning at normal speed
    Bottom Right Rear fan OK        Spinning at normal speed
    Rear Tray Top fan     OK         Spinning at normal speed
    Rear Tray Second fan  OK         Spinning at normal speed
    Rear Tray Third fan   OK         Spinning at normal speed
```

	Rear Tray Fourth fan	OK	Spinning at normal speed
	Rear Tray Fifth fan	OK	Spinning at normal speed
	Rear Tray Sixth fan	OK	Spinning at normal speed
	Rear Tray Seventh fan	OK	Spinning at normal speed
	Rear Tray Bottom fan	OK	Spinning at normal speed
Misc	CIP 0	OK	
	CIP 1	OK	
	SPMB 0	OK	
	SPMB 1	OK	

lcc0-re0:

```
-----
```

Class	Item	Status	Measurement
Temp	PEM 0	OK	29 degrees C / 84 degrees F
	PEM 1	Absent	
	SCG 0	OK	35 degrees C / 95 degrees F
	SCG 1	Absent	
	Routing Engine 0	OK	39 degrees C / 102 degrees F
	Routing Engine 1	OK	36 degrees C / 96 degrees F
	CB 0	OK	32 degrees C / 89 degrees F
	CB 1	OK	32 degrees C / 89 degrees F
	SIB 0	OK	40 degrees C / 104 degrees F
	SIB 0 (B)	OK	51 degrees C / 123 degrees F
	FPC 0 Top	OK	45 degrees C / 113 degrees F
	FPC 0 Bottom	OK	31 degrees C / 87 degrees F
	FPC 1 Top	OK	34 degrees C / 93 degrees F
	FPC 1 Bottom	OK	31 degrees C / 87 degrees F
	FPM GBUS	OK	30 degrees C / 86 degrees F
	FPM Display	OK	34 degrees C / 93 degrees F
Fans	Top Left Front fan	OK	Spinning at normal speed
	Top Left Middle fan	OK	Spinning at normal speed
	Top Left Rear fan	OK	Spinning at normal speed
	Top Right Front fan	OK	Spinning at normal speed
	Top Right Middle fan	OK	Spinning at normal speed
	Top Right Rear fan	OK	Spinning at normal speed
	Bottom Left Front fan	OK	Spinning at normal speed
	Bottom Left Middle fan	OK	Spinning at normal speed
	Bottom Left Rear fan	OK	Spinning at normal speed
	Bottom Right Front fan	OK	Spinning at normal speed
	Bottom Right Middle fan	OK	Spinning at normal speed
	Bottom Right Rear fan	OK	Spinning at normal speed
	Rear Tray Top fan	OK	Spinning at normal speed
	Rear Tray Second fan	OK	Spinning at normal speed

```

Rear Tray Third fan  OK      Spinning at normal speed
Rear Tray Fourth fan OK      Spinning at normal speed
Rear Tray Fifth fan  OK      Spinning at normal speed
Rear Tray Sixth fan  OK      Spinning at normal speed
Rear Tray Seventh fan OK      Spinning at normal speed
Rear Tray Bottom fan OK      Spinning at normal speed
Misc CIP              OK
  SPMB 0              OK
  SPMB 1              OK

```

```
lcc2-re0:
```

```

-----
Class Item          Status  Measurement
Temp PEM 0          OK      29 degrees C / 84 degrees F
  PEM 1            Absent
  SCG 0            OK      32 degrees C / 89 degrees F
  SCG 1            Absent
  Routing Engine 0 OK      31 degrees C / 87 degrees F
  Routing Engine 1 OK      32 degrees C / 89 degrees F
  CB 0             OK      30 degrees C / 86 degrees F
  SIB 0            OK      38 degrees C / 100 degrees F
  SIB 0 (B)        OK      49 degrees C / 120 degrees F
  FPC 0 Top         OK      45 degrees C / 113 degrees F
  FPC 0 Bottom      OK      33 degrees C / 91 degrees F
  FPC 1 Top         OK      37 degrees C / 98 degrees F
  FPC 1 Bottom      OK      33 degrees C / 91 degrees F
  FPM GBUS          OK      30 degrees C / 86 degrees F
  FPM Display       OK      34 degrees C / 93 degrees F
Fans Top Left Front OK      Spinning at normal speed
  Top Left Middle fan OK      Spinning at normal speed
...

```

show chassis environment (T1600 Router)

```

user@host> show chassis environment
Class Item          Status  Measurement
Temp PEM 0          OK      27 degrees C / 80 degrees F
  PEM 1            Absent
  SCG 0            OK      31 degrees C / 87 degrees F
  SCG 1            OK      35 degrees C / 95 degrees F
  Routing Engine 0 OK      30 degrees C / 86 degrees F

```

	Routing Engine 1	OK	30 degrees C / 86 degrees F
	CB 0	OK	31 degrees C / 87 degrees F
	CB 1	OK	31 degrees C / 87 degrees F
	SIB 0	OK	41 degrees C / 105 degrees F
	SIB 0 (B)	OK	34 degrees C / 93 degrees F
	SIB 1	OK	0 degrees C / 32 degrees F
	SIB 1 (B)	OK	0 degrees C / 32 degrees F
	SIB 2	OK	0 degrees C / 32 degrees F
	SIB 2 (B)	OK	0 degrees C / 32 degrees F
	SIB 3	OK	0 degrees C / 32 degrees F
	SIB 3 (B)	OK	0 degrees C / 32 degrees F
	SIB 4	OK	0 degrees C / 32 degrees F
	SIB 4 (B)	OK	0 degrees C / 32 degrees F
	FPC 0 Top	OK	49 degrees C / 120 degrees F
	FPC 0 Bottom	OK	50 degrees C / 122 degrees F
	FPC 1 Top	OK	48 degrees C / 118 degrees F
	FPC 1 Bottom	OK	49 degrees C / 120 degrees F
	FPM GBUS	OK	27 degrees C / 80 degrees F
	FPM Display	OK	30 degrees C / 86 degrees F
Fans	Top Left Front fan	OK	Spinning at normal speed
	Top Left Middle fan	OK	Spinning at normal speed
	Top Left Rear fan	OK	Spinning at normal speed
	Top Right Front fan	OK	Spinning at normal speed
	Top Right Middle fan	OK	Spinning at normal speed
	Top Right Rear fan	OK	Spinning at normal speed
	Bottom Left Front fan	OK	Spinning at normal speed
	Bottom Left Middle fan	OK	Spinning at normal speed
	Bottom Left Rear fan	OK	Spinning at normal speed
	Bottom Right Front fan	OK	Spinning at normal speed
	Bottom Right Middle fan	OK	Spinning at normal speed
	Bottom Right Rear fan	OK	Spinning at normal speed
	Rear Tray Top fan	OK	Spinning at normal speed
	Rear Tray Second fan	OK	Spinning at normal speed
	Rear Tray Third fan	OK	Spinning at normal speed
	Rear Tray Fourth fan	OK	Spinning at normal speed
	Rear Tray Fifth fan	OK	Spinning at normal speed
	Rear Tray Sixth fan	OK	Spinning at normal speed
	Rear Tray Seventh fan	OK	Spinning at normal speed
	Rear Tray Bottom fan	OK	Spinning at normal speed
Misc	CIP	OK	
	SPMB 0	OK	
	SPMB 1	OK	

show chassis environment (TX Matrix Plus Router)

```
user@host> show chassis environment
```

```
-----
Class Item                Status      Measurement
Temp PEM 0                OK          28 degrees C / 82 degrees F
    PEM 1                  Absent
    Routing Engine 0       OK          27 degrees C / 80 degrees F
    Routing Engine 1       OK          29 degrees C / 84 degrees F
    CB 0 Intake            OK          26 degrees C / 78 degrees F
    CB 0 Exhaust A        OK          25 degrees C / 77 degrees F
    CB 0 Exhaust B        OK          25 degrees C / 77 degrees F
    CB 1 Intake            OK          26 degrees C / 78 degrees F
    CB 1 Exhaust A        OK          26 degrees C / 78 degrees F
    CB 1 Exhaust B        OK          26 degrees C / 78 degrees F
    SIB F13 0              OK          47 degrees C / 116 degrees F
    SIB F13 0 (B)         OK          48 degrees C / 118 degrees F
    SIB F13 1              OK          38 degrees C / 100 degrees F
    SIB F13 1 (B)         OK          37 degrees C / 98 degrees F
    SIB F2S 0/0            OK          27 degrees C / 80 degrees F
    SIB F2S 0/2            OK          28 degrees C / 82 degrees F
    SIB F2S 0/4            OK          27 degrees C / 80 degrees F
    SIB F2S 0/6            OK          28 degrees C / 82 degrees F
    SIB F2S 1/0            OK          26 degrees C / 78 degrees F
    SIB F2S 1/2            OK          26 degrees C / 78 degrees F
    SIB F2S 1/4            OK          26 degrees C / 78 degrees F
    SIB F2S 1/6            OK          26 degrees C / 78 degrees F
    SIB F2S 2/0            OK          25 degrees C / 77 degrees F
    SIB F2S 2/2            OK          25 degrees C / 77 degrees F
    SIB F2S 2/4            OK          23 degrees C / 73 degrees F
    CIP 0 Intake           OK          23 degrees C / 73 degrees F
    CIP 0 Exhaust A       OK          24 degrees C / 75 degrees F
    CIP 0 Exhaust B       OK          24 degrees C / 75 degrees F
    CIP 1 Intake           OK          24 degrees C / 75 degrees F
    CIP 1 Exhaust A       OK          25 degrees C / 77 degrees F
    CIP 1 Exhaust B       OK          25 degrees C / 77 degrees F
Fans Fan Tray 0 Fan 1      OK          Spinning at normal speed
    Fan Tray 0 Fan 2      OK          Spinning at normal speed
    Fan Tray 0 Fan 3      OK          Spinning at normal speed
    Fan Tray 0 Fan 4      OK          Spinning at normal speed
    Fan Tray 0 Fan 5      OK          Spinning at normal speed
```

Fan Tray 0 Fan 6	OK	Spinning at normal speed
Fan Tray 1 Fan 1	OK	Spinning at normal speed
Fan Tray 1 Fan 2	OK	Spinning at normal speed
Fan Tray 1 Fan 3	OK	Spinning at normal speed
Fan Tray 1 Fan 4	OK	Spinning at normal speed
Fan Tray 1 Fan 5	OK	Spinning at normal speed
Fan Tray 1 Fan 6	OK	Spinning at normal speed
Fan Tray 2 Fan 1	OK	Spinning at normal speed
Fan Tray 2 Fan 2	OK	Spinning at normal speed
Fan Tray 2 Fan 3	OK	Spinning at normal speed
Fan Tray 2 Fan 4	OK	Spinning at normal speed
Fan Tray 2 Fan 5	OK	Spinning at normal speed
Fan Tray 2 Fan 6	OK	Spinning at normal speed
Fan Tray 2 Fan 7	OK	Spinning at normal speed
Fan Tray 2 Fan 8	OK	Spinning at normal speed
Fan Tray 2 Fan 9	OK	Spinning at normal speed
Fan Tray 3 Fan 1	OK	Spinning at normal speed
Fan Tray 3 Fan 2	OK	Spinning at normal speed
Fan Tray 3 Fan 3	OK	Spinning at normal speed
Fan Tray 3 Fan 4	OK	Spinning at normal speed
Fan Tray 3 Fan 5	OK	Spinning at normal speed
Fan Tray 3 Fan 6	OK	Spinning at normal speed
Fan Tray 3 Fan 7	OK	Spinning at normal speed
Fan Tray 3 Fan 8	OK	Spinning at normal speed
Fan Tray 3 Fan 9	OK	Spinning at normal speed
Fan Tray 4 Fan 1	OK	Spinning at normal speed
Fan Tray 4 Fan 2	OK	Spinning at normal speed
Fan Tray 4 Fan 3	OK	Spinning at normal speed
Fan Tray 4 Fan 4	OK	Spinning at normal speed
Fan Tray 4 Fan 5	OK	Spinning at normal speed
Fan Tray 4 Fan 6	OK	Spinning at normal speed
Fan Tray 4 Fan 7	OK	Spinning at normal speed
Fan Tray 4 Fan 8	OK	Spinning at normal speed
Fan Tray 4 Fan 9	OK	Spinning at normal speed
Fan Tray 5 Fan 1	OK	Spinning at normal speed
Fan Tray 5 Fan 2	OK	Spinning at normal speed
Fan Tray 5 Fan 3	OK	Spinning at normal speed
Fan Tray 5 Fan 4	OK	Spinning at normal speed
Fan Tray 5 Fan 5	OK	Spinning at normal speed
Fan Tray 5 Fan 6	OK	Spinning at normal speed
Fan Tray 5 Fan 7	OK	Spinning at normal speed
Fan Tray 5 Fan 8	OK	Spinning at normal speed
Fan Tray 5 Fan 9	OK	Spinning at normal speed

```
Misc SPMB 0          OK
      SPMB 1          OK
```

```
lcc0-re0:
```

```
-----
Class Item          Status      Measurement
Temp PEM 0          OK          27 degrees C / 80 degrees F
      PEM 1          Absent
      SCG 0          OK          31 degrees C / 87 degrees F
      SCG 1          OK          35 degrees C / 95 degrees F
      Routing Engine 0 OK          30 degrees C / 86 degrees F
      Routing Engine 1 OK          30 degrees C / 86 degrees F
      CB 0           OK          31 degrees C / 87 degrees F
      CB 1           OK          31 degrees C / 87 degrees F
      SIB 0          OK          41 degrees C / 105 degrees F
      SIB 0 (B)      OK          34 degrees C / 93 degrees F
      SIB 1          OK          0 degrees C / 32 degrees F
      SIB 1 (B)      OK          0 degrees C / 32 degrees F
      SIB 2          OK          0 degrees C / 32 degrees F
      SIB 2 (B)      OK          0 degrees C / 32 degrees F
      SIB 3          OK          0 degrees C / 32 degrees F
      SIB 3 (B)      OK          0 degrees C / 32 degrees F
      SIB 4          OK          0 degrees C / 32 degrees F
      SIB 4 (B)      OK          0 degrees C / 32 degrees F
      FPC 0 Top       OK          49 degrees C / 120 degrees F
      FPC 0 Bottom   OK          50 degrees C / 122 degrees F
      FPC 1 Top       OK          48 degrees C / 118 degrees F
      FPC 1 Bottom   OK          49 degrees C / 120 degrees F
      FPM GBUS       OK          27 degrees C / 80 degrees F
      FPM Display    OK          30 degrees C / 86 degrees F
Fans Top Left Front fan OK          Spinning at normal speed
      Top Left Middle fan OK          Spinning at normal speed
      Top Left Rear fan OK          Spinning at normal speed
      Top Right Front fan OK          Spinning at normal speed
      Top Right Middle fan OK          Spinning at normal speed
      Top Right Rear fan OK          Spinning at normal speed
      Bottom Left Front fan OK          Spinning at normal speed
      Bottom Left Middle fan OK          Spinning at normal speed
      Bottom Left Rear fan OK          Spinning at normal speed
      Bottom Right Front fan OK          Spinning at normal speed
      Bottom Right Middle fan OK          Spinning at normal speed
      Bottom Right Rear fan OK          Spinning at normal speed
      Rear Tray Top fan OK          Spinning at normal speed
```

	Rear Tray Second fan	OK	Spinning at normal speed
	Rear Tray Third fan	OK	Spinning at normal speed
	Rear Tray Fourth fan	OK	Spinning at normal speed
	Rear Tray Fifth fan	OK	Spinning at normal speed
	Rear Tray Sixth fan	OK	Spinning at normal speed
	Rear Tray Seventh fan	OK	Spinning at normal speed
	Rear Tray Bottom fan	OK	Spinning at normal speed
Misc	CIP	OK	
	SPMB 0	OK	
	SPMB 1	OK	

show chassis environment (TX Matrix Plus router with 3D SIBs)

```
user@host> show chassis environment
```

```
-----
Class Item                               Status Measurement
Temp PEM 0                               Check 30 degrees C / 86 degrees F
      PEM 1                               OK    33 degrees C / 91 degrees F
      Routing Engine 0                     OK    28 degrees C / 82 degrees F
      Routing Engine 0 CPU                   OK    42 degrees C / 107 degrees F
      Routing Engine 1                       OK    29 degrees C / 84 degrees F
      Routing Engine 1 CPU                   OK    44 degrees C / 111 degrees F
      CB 0 Intake                           OK    30 degrees C / 86 degrees F
      CB 0 Exhaust A                         OK    28 degrees C / 82 degrees F
      CB 0 Exhaust B                         OK    30 degrees C / 86 degrees F
      CB 1 Intake                           OK    31 degrees C / 87 degrees F
      CB 1 Exhaust A                         OK    27 degrees C / 80 degrees F
      CB 1 Exhaust B                         OK    31 degrees C / 87 degrees F
      SIB F13 0 Board                         OK    44 degrees C / 111 degrees F
      SIB F13 0 XF Junction                  OK    62 degrees C / 143 degrees F
      SIB F13 3 Board                         OK    45 degrees C / 113 degrees F
      SIB F13 3 XF Junction                  OK    60 degrees C / 140 degrees F
      SIB F13 6 Board                         OK    47 degrees C / 116 degrees F
      SIB F13 6 XF Junction                  OK    62 degrees C / 143 degrees F
      SIB F2S 0/0 Board                       OK    32 degrees C / 89 degrees F
      SIB F2S 0/0 XF Junction                OK    42 degrees C / 107 degrees F
      SIB F2S 0/2 Board                       OK    31 degrees C / 87 degrees F
      SIB F2S 0/2 XF Junction                OK    41 degrees C / 105 degrees F
      SIB F2S 0/4 Board                       OK    31 degrees C / 87 degrees F
      SIB F2S 0/4 XF Junction                OK    42 degrees C / 107 degrees F
```

SIB F2S 0/6 Board	OK	31 degrees C / 87 degrees F
SIB F2S 0/6 XF Junction	OK	41 degrees C / 105 degrees F
SIB F2S 1/0 Board	OK	31 degrees C / 87 degrees F
SIB F2S 1/0 XF Junction	OK	41 degrees C / 105 degrees F
SIB F2S 1/2 Board	OK	29 degrees C / 84 degrees F
SIB F2S 1/2 XF Junction	OK	39 degrees C / 102 degrees F
SIB F2S 1/4 Board	OK	29 degrees C / 84 degrees F
SIB F2S 1/4 XF Junction	OK	35 degrees C / 95 degrees F
SIB F2S 1/6 Board	OK	30 degrees C / 86 degrees F
SIB F2S 1/6 XF Junction	OK	41 degrees C / 105 degrees F
SIB F2S 2/0 Board	OK	30 degrees C / 86 degrees F
SIB F2S 2/0 XF Junction	OK	42 degrees C / 107 degrees F
SIB F2S 2/2 Board	OK	28 degrees C / 82 degrees F
SIB F2S 2/2 XF Junction	OK	39 degrees C / 102 degrees F
SIB F2S 2/4 Board	OK	29 degrees C / 84 degrees F
SIB F2S 2/4 XF Junction	OK	42 degrees C / 107 degrees F
SIB F2S 2/6 Board	OK	29 degrees C / 84 degrees F
SIB F2S 2/6 XF Junction	OK	41 degrees C / 105 degrees F
CIP 0 Intake	OK	25 degrees C / 77 degrees F
CIP 0 Exhaust A	OK	26 degrees C / 78 degrees F
CIP 0 Exhaust B	OK	26 degrees C / 78 degrees F
CIP 1 Intake	OK	26 degrees C / 78 degrees F
CIP 1 Exhaust A	OK	27 degrees C / 80 degrees F
CIP 1 Exhaust B	OK	27 degrees C / 80 degrees F
Fans Fan Tray 0 Fan 1	OK	Spinning at normal speed
Fan Tray 0 Fan 2	OK	Spinning at normal speed
Fan Tray 0 Fan 3	OK	Spinning at normal speed
Fan Tray 0 Fan 4	OK	Spinning at normal speed
Fan Tray 0 Fan 5	OK	Spinning at normal speed
Fan Tray 0 Fan 6	OK	Spinning at normal speed
Fan Tray 1 Fan 1	OK	Spinning at normal speed
Fan Tray 1 Fan 2	OK	Spinning at normal speed
Fan Tray 1 Fan 3	OK	Spinning at normal speed
Fan Tray 1 Fan 4	OK	Spinning at normal speed
Fan Tray 1 Fan 5	OK	Spinning at normal speed
Fan Tray 1 Fan 6	OK	Spinning at normal speed
Fan Tray 2 Fan 1	OK	Spinning at normal speed
Fan Tray 2 Fan 2	OK	Spinning at normal speed
Fan Tray 2 Fan 3	OK	Spinning at normal speed
Fan Tray 2 Fan 4	OK	Spinning at normal speed
Fan Tray 2 Fan 5	OK	Spinning at normal speed
Fan Tray 2 Fan 6	OK	Spinning at normal speed
Fan Tray 2 Fan 7	OK	Spinning at normal speed

Fan Tray 2 Fan 8	OK	Spinning at normal speed
Fan Tray 2 Fan 9	OK	Spinning at normal speed
Fan Tray 3 Fan 1	OK	Spinning at normal speed
Fan Tray 3 Fan 2	OK	Spinning at normal speed
Fan Tray 3 Fan 3	OK	Spinning at normal speed
Fan Tray 3 Fan 4	OK	Spinning at normal speed
Fan Tray 3 Fan 5	OK	Spinning at normal speed
Fan Tray 3 Fan 6	OK	Spinning at normal speed
Fan Tray 3 Fan 7	OK	Spinning at normal speed
Fan Tray 3 Fan 8	OK	Spinning at normal speed
Fan Tray 3 Fan 9	OK	Spinning at normal speed
Fan Tray 4 Fan 1	OK	Spinning at normal speed
Fan Tray 4 Fan 2	OK	Spinning at normal speed
Fan Tray 4 Fan 3	OK	Spinning at normal speed
Fan Tray 4 Fan 4	OK	Spinning at normal speed
Fan Tray 4 Fan 5	OK	Spinning at normal speed
Fan Tray 4 Fan 6	OK	Spinning at normal speed
Fan Tray 4 Fan 7	OK	Spinning at normal speed
Fan Tray 4 Fan 8	OK	Spinning at normal speed
Fan Tray 4 Fan 9	OK	Spinning at normal speed
Fan Tray 5 Fan 1	OK	Spinning at normal speed
Fan Tray 5 Fan 2	OK	Spinning at normal speed
Fan Tray 5 Fan 3	OK	Spinning at normal speed
Fan Tray 5 Fan 4	OK	Spinning at normal speed
Fan Tray 5 Fan 5	OK	Spinning at normal speed
Fan Tray 5 Fan 6	OK	Spinning at normal speed
Fan Tray 5 Fan 7	OK	Spinning at normal speed
Fan Tray 5 Fan 8	OK	Spinning at normal speed
Fan Tray 5 Fan 9	Check	
Misc SPMB 0	OK	
SPMB 1	OK	

lcc0-re0:

```
-----
```

Class	Item	Status	Measurement
Temp	PEM 0	OK	29 degrees C / 84 degrees F
	PEM 1	Check	29 degrees C / 84 degrees F
	SCG 0	OK	32 degrees C / 89 degrees F
	SCG 1	OK	33 degrees C / 91 degrees F
	Routing Engine 0	OK	32 degrees C / 89 degrees F
	Routing Engine 0 CPU	OK	51 degrees C / 123 degrees F
	Routing Engine 1	OK	32 degrees C / 89 degrees F
	Routing Engine 1 CPU	OK	49 degrees C / 120 degrees F

CB 0	OK	34 degrees C / 93 degrees F
CB 1	OK	34 degrees C / 93 degrees F
SIB 0	OK	39 degrees C / 102 degrees F
SIB 0 (B)	Absent	
SIB 1	OK	39 degrees C / 102 degrees F
SIB 1 (B)	Absent	
SIB 2	OK	39 degrees C / 102 degrees F
SIB 2 (B)	Absent	
FPC 4 Top	OK	43 degrees C / 109 degrees F
FPC 4 Bottom	OK	43 degrees C / 109 degrees F
FPC 7 Fan Intake	OK	35 degrees C / 95 degrees F
FPC 7 Fan Exhaust	OK	50 degrees C / 122 degrees F
FPC 7 PMB	OK	50 degrees C / 122 degrees F
FPC 7 LMB0	OK	55 degrees C / 131 degrees F
FPC 7 LMB1	OK	49 degrees C / 120 degrees F
FPC 7 LMB2	OK	39 degrees C / 102 degrees F
FPC 7 PFE1 LU2	OK	55 degrees C / 131 degrees F
FPC 7 PFE1 LU0	OK	45 degrees C / 113 degrees F
FPC 7 PFE0 LU0	OK	62 degrees C / 143 degrees F
FPC 7 XF1	OK	52 degrees C / 125 degrees F
FPC 7 XF0	OK	61 degrees C / 141 degrees F
FPC 7 XM1	OK	39 degrees C / 102 degrees F
FPC 7 XM0	OK	56 degrees C / 132 degrees F
FPC 7 PFE0 LU1	OK	60 degrees C / 140 degrees F
FPC 7 PFE0 LU2	OK	55 degrees C / 131 degrees F
FPC 7 PFE1 LU1	OK	41 degrees C / 105 degrees F
FPM GBUS	OK	24 degrees C / 75 degrees F
FPM Display	OK	28 degrees C / 82 degrees F
Fans Top Left Front fan	OK	Spinning at normal speed
Top Left Middle fan	OK	Spinning at normal speed
Top Left Rear fan	OK	Spinning at normal speed
Top Right Front fan	OK	Spinning at normal speed
Top Right Middle fan	OK	Spinning at normal speed
Top Right Rear fan	OK	Spinning at normal speed
Bottom Left Front fan	OK	Spinning at normal speed
Bottom Left Middle fan	OK	Spinning at normal speed
Bottom Left Rear fan	OK	Spinning at normal speed
Bottom Right Front fan	OK	Spinning at normal speed
Bottom Right Middle fan	OK	Spinning at normal speed
Bottom Right Rear fan	OK	Spinning at normal speed
Rear Tray fan 1 (Top)	OK	Spinning at normal speed
Rear Tray fan 2	OK	Spinning at normal speed
Rear Tray fan 3	OK	Spinning at normal speed

Rear Tray fan 4	OK	Spinning at normal speed
Rear Tray fan 5	OK	Spinning at normal speed
Rear Tray fan 6	OK	Spinning at normal speed
Rear Tray fan 7	OK	Spinning at normal speed
Rear Tray fan 8	OK	Spinning at normal speed
Rear Tray fan 9	OK	Spinning at normal speed
Rear Tray fan 10	OK	Spinning at normal speed
Rear Tray fan 11	OK	Spinning at normal speed
Rear Tray fan 12	OK	Spinning at normal speed
Rear Tray fan 13	OK	Spinning at normal speed
Rear Tray fan 14	OK	Spinning at normal speed
Rear Tray fan 15	OK	Spinning at normal speed
Rear Tray fan 16 (Bottom)	OK	Spinning at normal speed
Misc CIP	OK	
SPMB 0	OK	
SPMB 1	OK	

show chassis environment (EX4200 Standalone Switch)

```

user@switch> show chassis environment
Class Item                               Status      Measurement
Power FPC 0 Power Supply 0               OK
      FPC 0 Power Supply 1               Absent
Temp  FPC 0 CPU                           OK          41 degrees C / 105 degrees F
      FPC 0 EX-PFE1                       OK          42 degrees C / 107 degrees F
      FPC 0 EX-PFE2                       OK          46 degrees C / 114 degrees F
      FPC 0 GEPHY Front Left              OK          25 degrees C / 77 degrees F
      FPC 0 GEPHY Front Right             OK          27 degrees C / 80 degrees F
      FPC 0 Uplink Conn                   OK          29 degrees C / 84 degrees F
Fans  FPC 0 Fan 1                         OK          Spinning at normal speed
      FPC 0 Fan 2                         OK          Spinning at normal speed
      FPC 0 Fan 3                         OK          Spinning at normal speed

```

show chassis environment (EX8216 Switch)

```

user@switch> show chassis environment
Class Item                               Status      Measurement
Power PSU 0                              OK
      PSU 1                              OK
      PSU 2                              OK

```

	PSU 3	Check	
	PSU 4	Absent	
	PSU 5	Absent	
Temp	CB 0 Intake	OK	23 degrees C / 73 degrees F
	CB 0 Exhaust	OK	26 degrees C / 78 degrees F
	CB 1 Intake	OK	22 degrees C / 71 degrees F
	CB 1 Exhaust	OK	25 degrees C / 77 degrees F
	FPC 4 Intake	OK	49 degrees C / 120 degrees F
	FPC 4 Exhaust	OK	59 degrees C / 138 degrees F
	SIB 5 Intake	OK	25 degrees C / 77 degrees F
	SIB 5 Exhaust	OK	35 degrees C / 95 degrees F
	SIB 6 Intake	OK	25 degrees C / 77 degrees F
	SIB 6 Exhaust	OK	38 degrees C / 100 degrees F
Fans	Top Fan 1	OK	Spinning at normal speed
	Top Fan 2	OK	Spinning at normal speed
	Top Fan 3	OK	Spinning at normal speed
	Top Fan 4	OK	Spinning at normal speed
	Top Fan 5	OK	Spinning at normal speed
	Top Fan 6	OK	Spinning at normal speed
	Top Fan 7	OK	Spinning at normal speed
	Top Fan 8	OK	Spinning at normal speed
	Top Fan 9	OK	Spinning at normal speed
	Bottom Fan 1	OK	Spinning at normal speed
	Bottom Fan 2	OK	Spinning at normal speed
	Bottom Fan 3	OK	Spinning at normal speed
	Bottom Fan 4	OK	Spinning at normal speed
	Bottom Fan 5	OK	Spinning at normal speed
	Bottom Fan 6	OK	Spinning at normal speed
	Bottom Fan 7	OK	Spinning at normal speed
	Bottom Fan 8	OK	Spinning at normal speed
	Bottom Fan 9	OK	Spinning at normal speed

show chassis environment (EX9200 Switch)

```
user@switch> show chassis environment
```

Class	Item	Status	Measurement
Temp	PEM 0	Check	
	PEM 1	OK	40 degrees C / 104 degrees F
	PEM 2	OK	40 degrees C / 104 degrees F
	PEM 3	Absent	

```

Routing Engine 0          OK          35 degrees C / 95 degrees F
Routing Engine 0 CPU      OK          33 degrees C / 91 degrees F
Routing Engine 1          OK          38 degrees C / 100 degrees F
Routing Engine 1 CPU      OK          33 degrees C / 91 degrees F
CB 0 Intake               OK          35 degrees C / 95 degrees F
CB 0 Exhaust A           OK          33 degrees C / 91 degrees F
CB 0 Exhaust B           OK          40 degrees C / 104 degrees F
CB 0 ACBC                 OK          39 degrees C / 102 degrees F
CB 0 XF A                 OK          49 degrees C / 120 degrees F
CB 0 XF B                 OK          46 degrees C / 114 degrees F
CB 1 Intake               OK          37 degrees C / 98 degrees F
CB 1 Exhaust A           OK          32 degrees C / 89 degrees F
CB 1 Exhaust B           OK          39 degrees C / 102 degrees F
CB 1 ACBC                 OK          41 degrees C / 105 degrees F
CB 1 XF A                 OK          49 degrees C / 120 degrees F
CB 1 XF B                 OK          49 degrees C / 120 degrees F
FPC 2 Intake              OK          37 degrees C / 98 degrees F
FPC 2 Exhaust A          OK          40 degrees C / 104 degrees F
FPC 2 Exhaust B          OK          34 degrees C / 93 degrees F
FPC 2 LU 0 TCAM TSen     OK          44 degrees C / 111 degrees F
FPC 2 LU 0 TCAM Chip     OK          48 degrees C / 118 degrees F
FPC 2 LU 0 TSen          OK          44 degrees C / 111 degrees F
FPC 2 LU 0 Chip          OK          60 degrees C / 140 degrees F
FPC 2 MQ 0 TSen          OK          44 degrees C / 111 degrees F
FPC 2 MQ 0 Chip          OK          51 degrees C / 123 degrees F
FPC 3 Intake              OK          39 degrees C / 102 degrees F
FPC 3 Exhaust A          OK          51 degrees C / 123 degrees F

```

[...Output truncated...]

```

Fans  Top Rear Fan       OK          Spinning at intermediate-speed
      Bottom Rear Fan    OK          Spinning at intermediate-speed
      Top Middle Fan      OK          Spinning at intermediate-speed
      Bottom Middle Fan   OK          Spinning at intermediate-speed
      Top Front Fan       OK          Spinning at intermediate-speed
      Bottom Front Fan    OK          Spinning at intermediate-speed

```

show chassis environment (EX9251 Switch)

```
user@switch> show chassis environment
```

Class	Item	Status	Measurement
Temp	CB 0 Top Right Inlet Sensor	OK	29 degrees C / 84 degrees F
	CB 0 Top Left Inlet Sensor	OK	29 degrees C / 84 degrees F
	CB 0 Top Right Exhaust Sensor	OK	40 degrees C / 104 degrees F
	CB 0 Top Left Exhaust Sensor	OK	59 degrees C / 138 degrees F
	CB 0 CPU Core-0 Temp	OK	45 degrees C / 113 degrees F
	CB 0 CPU Core-1 Temp	OK	44 degrees C / 111 degrees F
	CB 0 CPU Core-2 Temp	OK	44 degrees C / 111 degrees F
	CB 0 CPU Core-3 Temp	OK	44 degrees C / 111 degrees F
	CB 0 CPU Core-4 Temp	OK	45 degrees C / 113 degrees F
	CB 0 CPU Core-5 Temp	OK	44 degrees C / 111 degrees F
	CB 0 CPU Core-6 Temp	OK	44 degrees C / 111 degrees F
	CB 0 CPU Core-7 Temp	OK	43 degrees C / 109 degrees F
Power	PEM 0	Check	
	PEM 1	OK	36 degrees C / 96 degrees F
Fans	Fan Tray 0 Fan 0	OK	Spinning at normal speed
	Fan Tray 0 Fan 1	OK	Spinning at normal speed
	Fan Tray 1 Fan 0	OK	Spinning at normal speed
	Fan Tray 1 Fan 1	OK	Spinning at normal speed
	Fan Tray 2 Fan 0	Absent	
	Fan Tray 2 Fan 1	Absent	

show chassis environment (EX9253 Switch)

```
user@switch> show chassis environment
```

Class	Item	Status	Measurement
Temp	CB 0 Exhaust Temp Sensor	OK	37 degrees C / 98 degrees F
	CB 0 Inlet Temp Sensor	OK	31 degrees C / 87 degrees F
	CB 0 CPU DIE Temp Sensor	OK	42 degrees C / 107 degrees F
	CB 1 Exhaust Temp Sensor	OK	31 degrees C / 87 degrees F
	CB 1 Inlet Temp Sensor	OK	28 degrees C / 82 degrees F
	CB 1 CPU DIE Temp Sensor	OK	42 degrees C / 107 degrees F
	FPC 0 Intake Temp Sensor	OK	31 degrees C / 87 degrees F
	FPC 0 Exhaust-A Temp Sensor	OK	58 degrees C / 136 degrees F
	FPC 0 Exhaust-B Temp Sensor	OK	47 degrees C / 116 degrees F
	FPC 1 Intake Temp Sensor	OK	29 degrees C / 84 degrees F
	FPC 1 Exhaust-A Temp Sensor	OK	59 degrees C / 138 degrees F
	FPC 1 Exhaust-B Temp Sensor	OK	48 degrees C / 118 degrees F
Power	PEM 0	OK	54 degrees C / 129 degrees F
	PEM 1	Check	

```

PEM 2                Absent
PEM 3                Absent
PEM 4                Check
PEM 5                OK          61 degrees C / 141 degrees F
Fans Fan Tray 0 Fan 0  OK          Spinning at normal speed
      Fan Tray 0 Fan 1  OK          Spinning at normal speed
      Fan Tray 0 Fan 2  OK          Spinning at normal speed
      Fan Tray 0 Fan 3  OK          Spinning at normal speed
      Fan Tray 1 Fan 0  OK          Spinning at normal speed
      Fan Tray 1 Fan 1  OK          Spinning at normal speed
      Fan Tray 1 Fan 2  OK          Spinning at normal speed
      Fan Tray 1 Fan 3  OK          Spinning at normal speed
      Fan Tray 2 Fan 0  OK          Spinning at normal speed
      Fan Tray 2 Fan 1  OK          Spinning at normal speed
      Fan Tray 2 Fan 2  OK          Spinning at normal speed
      Fan Tray 2 Fan 3  OK          Spinning at normal speed
      Fan Tray 3 Fan 0  OK          Spinning at normal speed
      Fan Tray 3 Fan 1  OK          Spinning at normal speed
      Fan Tray 3 Fan 2  OK          Spinning at normal speed
      Fan Tray 3 Fan 3  OK          Spinning at normal speed

```

show chassis environment (QFX Series and OCX Series)

```

user@switch> show chassis environment
Class Item                Status  Measurement
Temp CB 0 Top Right Inlet Sensor  OK     29 degrees C / 84 degrees F
      CB 0 Top Left Inlet Sensor  OK     29 degrees C / 84 degrees F
      CB 0 Top Right Exhaust Sensor OK     40 degrees C / 104 degrees F
      CB 0 Top Left Exhaust Sensor OK     59 degrees C / 138 degrees F
      CB 0 CPU Core-0 Temp        OK     45 degrees C / 113 degrees F
      CB 0 CPU Core-1 Temp        OK     44 degrees C / 111 degrees F
      CB 0 CPU Core-2 Temp        OK     44 degrees C / 111 degrees F
      CB 0 CPU Core-3 Temp        OK     44 degrees C / 111 degrees F
      CB 0 CPU Core-4 Temp        OK     45 degrees C / 113 degrees F
      CB 0 CPU Core-5 Temp        OK     44 degrees C / 111 degrees F
      CB 0 CPU Core-6 Temp        OK     44 degrees C / 111 degrees F
      CB 0 CPU Core-7 Temp        OK     43 degrees C / 109 degrees F
Power PEM 0                Check
      PEM 1                OK     36 degrees C / 96 degrees F
Fans  Fan Tray 0 Fan 0  OK     Spinning at normal speed
      Fan Tray 0 Fan 1  OK     Spinning at normal speed

```

Fan Tray 1 Fan 0	OK	Spinning at normal speed
Fan Tray 1 Fan 1	OK	Spinning at normal speed
Fan Tray 2 Fan 0	Absent	
Fan Tray 2 Fan 1	Absent	

show chassis environment interconnect-device (QFabric System)

```

user@switch> show chassis environment interconnect-device
IC-A0004
Class Item                               Status      Measurement
CB 0
CB 0 L Intake                            OK          30 degrees C / 86 degrees F
CB 0 R Intake                            OK          31 degrees C / 87 degrees F
CB 0 L Exhaust                           OK          32 degrees C / 89 degrees F
CB 0 R Exhaust                           OK          33 degrees C / 91 degrees F
Routing Engine 0 CPU temp                 OK          51 degrees C / 123 degrees F
CB 1
CB 1 L Intake                            OK          27 degrees C / 80 degrees F
CB 1 R Intake                            OK          29 degrees C / 84 degrees F
CB 1 L Exhaust                           OK          31 degrees C / 87 degrees F
CB 1 R Exhaust                           OK          32 degrees C / 89 degrees F
Routing Engine 1 CPU temp                 OK          40 degrees C / 104 degrees F
FC 0 FPC 0
FPC 0 L Intake                           OK          25 degrees C / 77 degrees F
FPC 0 R Intake                           OK          28 degrees C / 82 degrees F
FPC 0 L Exhaust                           OK          28 degrees C / 82 degrees F
FPC 0 R Exhaust                           OK          29 degrees C / 84 degrees F
FC 7 FPC 7
FPC 7 L Intake                           OK          25 degrees C / 77 degrees F
FPC 7 R Intake                           OK          26 degrees C / 78 degrees F
FPC 7 L Exhaust                           OK          28 degrees C / 82 degrees F
FPC 7 R Exhaust                           OK          29 degrees C / 84 degrees F
RC 0 FPC 8
FPC 8 L Intake                           OK          25 degrees C / 77 degrees F
FPC 8 R Intake                           OK          26 degrees C / 78 degrees F
FPC 8 L Exhaust                           OK          32 degrees C / 89 degrees F
FPC 8 R Exhaust                           OK          30 degrees C / 86 degrees F
RC 7 FPC 15
FPC 15 L Intake                          OK          24 degrees C / 75 degrees F
FPC 15 R Intake                          OK          25 degrees C / 77 degrees F
FPC 15 L Exhaust                          OK          33 degrees C / 91 degrees F

```

FPC 15 R Exhaust	OK	31 degrees C / 87 degrees F
Fans TFT 0 Fan 0	OK	Spinning at normal speed
Fans TFT 0 Fan 1	OK	Spinning at normal speed
Fans TFT 0 Fan 2	OK	Spinning at normal speed
Fans TFT 0 Fan 3	OK	Spinning at normal speed
Fans TFT 0 Fan 4	OK	Spinning at normal speed
Fans TFT 0 Fan 5	OK	Spinning at normal speed
Fans BFT 1 Fan 0	OK	Spinning at normal speed
Fans BFT 1 Fan 1	OK	Spinning at normal speed
Fans BFT 1 Fan 2	OK	Spinning at normal speed
Fans BFT 1 Fan 3	Check	
Fans BFT 1 Fan 4	OK	Spinning at normal speed
Fans BFT 1 Fan 5	OK	Spinning at normal speed
Fans SFT 0 Fan 0 Rotor 0	OK	Spinning at normal speed
Fans SFT 0 Fan 0 Rotor 1	OK	Spinning at normal speed
Fans SFT 0 Fan 1 Rotor 0	OK	Spinning at normal speed
Fans SFT 0 Fan 1 Rotor 1	OK	Spinning at normal speed
Fans SFT 0 Fan 2 Rotor 0	OK	Spinning at normal speed
Fans SFT 0 Fan 2 Rotor 1	OK	Spinning at normal speed
Fans SFT 0 Fan 3 Rotor 0	OK	Spinning at normal speed
Fans SFT 0 Fan 3 Rotor 1	OK	Spinning at normal speed
Fans SFT 1 Fan 0 Rotor 0	OK	Spinning at normal speed
Fans SFT 1 Fan 0 Rotor 1	OK	Spinning at normal speed
Fans SFT 1 Fan 1 Rotor 0	OK	Spinning at normal speed
Fans SFT 1 Fan 1 Rotor 1	OK	Spinning at normal speed
Fans SFT 1 Fan 2 Rotor 0	OK	Spinning at normal speed
Fans SFT 1 Fan 2 Rotor 1	OK	Spinning at normal speed
Fans SFT 1 Fan 3 Rotor 0	OK	Spinning at normal speed
Fans SFT 1 Fan 3 Rotor 1	OK	Spinning at normal speed
Fans SFT 2 Fan 0 Rotor 0	OK	Spinning at normal speed
Fans SFT 2 Fan 0 Rotor 1	OK	Spinning at normal speed
Fans SFT 2 Fan 1 Rotor 0	OK	Spinning at normal speed
Fans SFT 2 Fan 1 Rotor 1	OK	Spinning at normal speed
Fans SFT 2 Fan 2 Rotor 0	OK	Spinning at normal speed
Fans SFT 2 Fan 2 Rotor 1	OK	Spinning at normal speed
Fans SFT 2 Fan 3 Rotor 0	OK	Spinning at normal speed
Fans SFT 2 Fan 3 Rotor 1	OK	Spinning at normal speed
Fans SFT 3 Fan 0 Rotor 0	OK	Spinning at normal speed
Fans SFT 3 Fan 0 Rotor 1	OK	Spinning at normal speed
Fans SFT 3 Fan 1 Rotor 0	OK	Spinning at normal speed
Fans SFT 3 Fan 1 Rotor 1	OK	Spinning at normal speed
Fans SFT 3 Fan 2 Rotor 0	OK	Spinning at normal speed
Fans SFT 3 Fan 2 Rotor 1	OK	Spinning at normal speed

Fans SFT 3 Fan 3 Rotor 0	OK	Spinning at normal speed
Fans SFT 3 Fan 3 Rotor 1	OK	Spinning at normal speed
Fans SFT 4 Fan 0 Rotor 0	OK	Spinning at normal speed
Fans SFT 4 Fan 0 Rotor 1	OK	Spinning at normal speed
Fans SFT 4 Fan 1 Rotor 0	OK	Spinning at normal speed
Fans SFT 4 Fan 1 Rotor 1	OK	Spinning at normal speed
Fans SFT 4 Fan 2 Rotor 0	OK	Spinning at normal speed
Fans SFT 4 Fan 2 Rotor 1	OK	Spinning at normal speed
Fans SFT 4 Fan 3 Rotor 0	OK	Spinning at normal speed
Fans SFT 4 Fan 3 Rotor 1	OK	Spinning at normal speed
Fans SFT 5 Fan 0 Rotor 0	OK	Spinning at normal speed
Fans SFT 5 Fan 0 Rotor 1	OK	Spinning at normal speed
Fans SFT 5 Fan 1 Rotor 0	OK	Spinning at normal speed
Fans SFT 5 Fan 1 Rotor 1	OK	Spinning at normal speed
Fans SFT 5 Fan 2 Rotor 0	OK	Spinning at normal speed
Fans SFT 5 Fan 2 Rotor 1	OK	Spinning at normal speed
Fans SFT 5 Fan 3 Rotor 0	OK	Spinning at normal speed
Fans SFT 5 Fan 3 Rotor 1	OK	Spinning at normal speed
Fans SFT 6 Fan 0 Rotor 0	OK	Spinning at normal speed
Fans SFT 6 Fan 0 Rotor 1	OK	Spinning at normal speed
Fans SFT 6 Fan 1 Rotor 0	OK	Spinning at normal speed
Fans SFT 6 Fan 1 Rotor 1	OK	Spinning at normal speed
Fans SFT 6 Fan 2 Rotor 0	OK	Spinning at normal speed
Fans SFT 6 Fan 2 Rotor 1	OK	Spinning at normal speed
Fans SFT 6 Fan 3 Rotor 0	OK	Spinning at normal speed
Fans SFT 6 Fan 3 Rotor 1	OK	Spinning at normal speed
Fans SFT 7 Fan 0 Rotor 0	OK	Spinning at normal speed
Fans SFT 7 Fan 0 Rotor 1	OK	Spinning at normal speed
Fans SFT 7 Fan 1 Rotor 0	OK	Spinning at normal speed
Fans SFT 7 Fan 1 Rotor 1	OK	Spinning at normal speed
Fans SFT 7 Fan 2 Rotor 0	OK	Spinning at normal speed
Fans SFT 7 Fan 2 Rotor 1	OK	Spinning at normal speed
Fans SFT 7 Fan 3 Rotor 0	OK	Spinning at normal speed
Fans SFT 7 Fan 3 Rotor 1	OK	Spinning at normal speed
Power PEM 0	OK	30 degrees C / 86 degrees F
Power PEM 1	OK	30 degrees C / 86 degrees F
Power PEM 2	OK	30 degrees C / 86 degrees F
Power PEM 3	Absent	
Power PEM 4	Absent	
Power PEM 5	Absent	

PDU 1	Absent	
CCG 0	OK	44 degrees C / 111 degrees F
CCG 1	OK	44 degrees C / 111 degrees F
Routing Engine 0	OK	62 degrees C / 143 degrees F
Routing Engine 0 CPU	OK	75 degrees C / 167 degrees F
Routing Engine 1	OK	51 degrees C / 123 degrees F
Routing Engine 1 CPU	OK	64 degrees C / 147 degrees F
CB 0 Intake	OK	38 degrees C / 100 degrees F
CB 0 Exhaust A	OK	46 degrees C / 114 degrees F
CB 0 Exhaust B	OK	42 degrees C / 107 degrees F
CB 1 Intake	OK	35 degrees C / 95 degrees F
CB 1 Exhaust A	OK	39 degrees C / 102 degrees F
CB 1 Exhaust B	OK	36 degrees C / 96 degrees F
SIB 0 Exhaust	OK	47 degrees C / 116 degrees F
SIB 0 Junction	OK	45 degrees C / 113 degrees F
SIB 1 Exhaust	OK	44 degrees C / 111 degrees F
SIB 1 Junction	OK	43 degrees C / 109 degrees F
SIB 2 Exhaust	OK	47 degrees C / 116 degrees F
SIB 2 Junction	OK	42 degrees C / 107 degrees F
SIB 3 Exhaust	OK	43 degrees C / 109 degrees F
SIB 3 Junction	OK	43 degrees C / 109 degrees F
SIB 4 Exhaust	OK	47 degrees C / 116 degrees F
SIB 4 Junction	OK	42 degrees C / 107 degrees F
SIB 5 Exhaust	OK	42 degrees C / 107 degrees F
SIB 5 Junction	OK	40 degrees C / 104 degrees F
SIB 6 Exhaust	OK	46 degrees C / 114 degrees F
SIB 6 Junction	OK	42 degrees C / 107 degrees F
SIB 7 Exhaust	OK	43 degrees C / 109 degrees F
SIB 7 Junction	OK	39 degrees C / 102 degrees F
SIB 8 Exhaust	OK	44 degrees C / 111 degrees F
SIB 8 Junction	OK	41 degrees C / 105 degrees F
FPC 0 PMB	OK	35 degrees C / 95 degrees F
FPC 0 Intake	OK	33 degrees C / 91 degrees F
FPC 0 Exhaust A	OK	51 degrees C / 123 degrees F
FPC 0 Exhaust B	OK	43 degrees C / 109 degrees F
FPC 0 TL0	OK	48 degrees C / 118 degrees F
FPC 0 TQ0	OK	53 degrees C / 127 degrees F
FPC 0 TL1	OK	56 degrees C / 132 degrees F
FPC 0 TQ1	OK	58 degrees C / 136 degrees F
FPC 0 TL2	OK	55 degrees C / 131 degrees F
FPC 0 TQ2	OK	56 degrees C / 132 degrees F
FPC 0 TL3	OK	59 degrees C / 138 degrees F
FPC 0 TQ3	OK	59 degrees C / 138 degrees F

FPC 2 PMB	OK	35 degrees C / 95 degrees F
FPC 2 Intake	OK	34 degrees C / 93 degrees F
FPC 2 Exhaust A	OK	51 degrees C / 123 degrees F
FPC 2 Exhaust B	OK	52 degrees C / 125 degrees F
FPC 2 TL0	OK	53 degrees C / 127 degrees F
FPC 2 TQ0	OK	53 degrees C / 127 degrees F
FPC 2 TL1	OK	57 degrees C / 134 degrees F
FPC 2 TQ1	OK	58 degrees C / 136 degrees F
FPC 2 TL2	OK	54 degrees C / 129 degrees F
FPC 2 TQ2	OK	59 degrees C / 138 degrees F
FPC 2 TL3	OK	60 degrees C / 140 degrees F
FPC 2 TQ3	OK	64 degrees C / 147 degrees F
PIC 2/0 Ambient	OK	49 degrees C / 120 degrees F
FPC 3 PMB	OK	34 degrees C / 93 degrees F
FPC 3 Intake	OK	35 degrees C / 95 degrees F
FPC 3 Exhaust A	OK	54 degrees C / 129 degrees F
FPC 3 Exhaust B	OK	49 degrees C / 120 degrees F
FPC 3 TL0	OK	49 degrees C / 120 degrees F
FPC 3 TQ0	OK	55 degrees C / 131 degrees F
FPC 3 TL1	OK	56 degrees C / 132 degrees F
FPC 3 TQ1	OK	58 degrees C / 136 degrees F
FPC 3 TL2	OK	56 degrees C / 132 degrees F
FPC 3 TQ2	OK	59 degrees C / 138 degrees F
FPC 3 TL3	OK	62 degrees C / 143 degrees F
FPC 3 TQ3	OK	63 degrees C / 145 degrees F
PIC 3/1	Absent	
FPC 5 PMB	OK	35 degrees C / 95 degrees F
FPC 5 Intake	OK	34 degrees C / 93 degrees F
FPC 5 Exhaust A	OK	51 degrees C / 123 degrees F
FPC 5 Exhaust B	OK	53 degrees C / 127 degrees F
FPC 5 TL0	OK	54 degrees C / 129 degrees F
FPC 5 TQ0	OK	52 degrees C / 125 degrees F
FPC 5 TL1	OK	61 degrees C / 141 degrees F
FPC 5 TQ1	OK	60 degrees C / 140 degrees F
FPC 5 TL2	OK	55 degrees C / 131 degrees F
FPC 5 TQ2	OK	55 degrees C / 131 degrees F
FPC 5 TL3	OK	59 degrees C / 138 degrees F
FPC 5 TQ3	OK	58 degrees C / 136 degrees F
PIC 5/0 Ambient	OK	51 degrees C / 123 degrees F
PIC 5/1 Ambient	OK	34 degrees C / 93 degrees F
PIC 5/1 cfp-5/1/0	OK	34 degrees C / 93 degrees F
PIC 5/1 cfp-5/1/1	OK	36 degrees C / 96 degrees F
FPC 6 PMB	OK	36 degrees C / 96 degrees F

FPC 6 Intake	OK	33 degrees C / 91 degrees F
FPC 6 Exhaust A	OK	51 degrees C / 123 degrees F
FPC 6 Exhaust B	OK	39 degrees C / 102 degrees F
FPC 6 TL0	OK	44 degrees C / 111 degrees F
FPC 6 TQ0	OK	54 degrees C / 129 degrees F
FPC 6 TL1	OK	59 degrees C / 138 degrees F
FPC 6 TQ1	OK	58 degrees C / 136 degrees F
FPC 6 TL2	OK	60 degrees C / 140 degrees F
FPC 6 TQ2	OK	57 degrees C / 134 degrees F
FPC 6 TL3	OK	65 degrees C / 149 degrees F
FPC 6 TQ3	OK	60 degrees C / 140 degrees F
FPC 7 PMB	OK	35 degrees C / 95 degrees F
FPC 7 Intake	OK	33 degrees C / 91 degrees F
FPC 7 Exhaust A	OK	53 degrees C / 127 degrees F
FPC 7 Exhaust B	OK	40 degrees C / 104 degrees F
FPC 7 TL0	OK	46 degrees C / 114 degrees F
FPC 7 TQ0	OK	58 degrees C / 136 degrees F
FPC 7 TL1	OK	53 degrees C / 127 degrees F
FPC 7 TQ1	OK	59 degrees C / 138 degrees F
FPC 7 TL2	OK	56 degrees C / 132 degrees F
FPC 7 TQ2	OK	61 degrees C / 141 degrees F
FPC 7 TL3	OK	63 degrees C / 145 degrees F
FPC 7 TQ3	OK	63 degrees C / 145 degrees F
FPM I2CS	OK	37 degrees C / 98 degrees F
Fans Fan Tray 0 Fan 1	OK	3042 RPM
Fans Fan Tray 0 Fan 2	OK	3042 RPM
Fans Fan Tray 0 Fan 3	OK	3000 RPM
Fans Fan Tray 0 Fan 4	OK	3042 RPM
Fans Fan Tray 0 Fan 5	OK	3000 RPM
Fans Fan Tray 0 Fan 6	OK	3042 RPM
Fans Fan Tray 0 Fan 7	OK	3085 RPM
Fans Fan Tray 0 Fan 8	OK	3042 RPM
Fans Fan Tray 0 Fan 9	OK	3042 RPM
Fans Fan Tray 0 Fan 10	OK	3085 RPM
Fans Fan Tray 0 Fan 11	OK	3085 RPM
Fans Fan Tray 0 Fan 12	OK	3128 RPM
Fans Fan Tray 0 Fan 13	OK	3128 RPM
Fans Fan Tray 0 Fan 14	OK	3042 RPM
Fans Fan Tray 1 Fan 1	OK	2299 RPM
Fans Fan Tray 1 Fan 2	OK	2399 RPM
Fans Fan Tray 1 Fan 3	OK	2299 RPM
Fans Fan Tray 1 Fan 4	OK	2266 RPM
Fans Fan Tray 1 Fan 5	OK	2266 RPM

	Fan Tray 1 Fan 6	OK	2366 RPM
	Fan Tray 2 Fan 1	OK	2199 RPM
	Fan Tray 2 Fan 2	OK	2133 RPM
	Fan Tray 2 Fan 3	OK	2366 RPM
	Fan Tray 2 Fan 4	OK	2233 RPM
	Fan Tray 2 Fan 5	OK	2399 RPM
	Fan Tray 2 Fan 6	OK	2233 RPM
Misc	SPMB 0 Intake	OK	50 degrees C / 122 degrees F
	SPMB 1 Intake	OK	40 degrees C / 104 degrees F

show chassis environment (PTX5000 Packet Transport Router with FPC2-PTX-P1A)

```

user@host> show chassis environment
Class Item                Status      Measurement
Temp PDU 0                OK
    PDU 0 PSM 0           OK          41 degrees C / 105 degrees F
    PDU 0 PSM 1           Absent
    PDU 0 PSM 2           OK          43 degrees C / 109 degrees F
    PDU 0 PSM 3           Absent
    PDU 0 PSM 4           OK          44 degrees C / 111 degrees F
    PDU 0 PSM 5           Absent
    PDU 0 PSM 6           OK          45 degrees C / 113 degrees F
    PDU 0 PSM 7           Absent
    PDU 1                 OK
    PDU 1 PSM 0           Absent
    PDU 1 PSM 1           OK          45 degrees C / 113 degrees F
    PDU 1 PSM 2           Absent
    PDU 1 PSM 3           OK          43 degrees C / 109 degrees F
    PDU 1 PSM 4           Absent
    PDU 1 PSM 5           OK          46 degrees C / 114 degrees F
    PDU 1 PSM 6           Absent
    PDU 1 PSM 7           OK          46 degrees C / 114 degrees F
    CCG 0                 OK          27 degrees C / 80 degrees F
    CCG 1                 OK          29 degrees C / 84 degrees F
...

```

show chassis environment (PTX1000 Packet Transport Router)

```

user@host> show chassis environment
Class Item                Status      Measurement

```

Power	FPC 0 Power Supply 0	Absent	
	FPC 0 Power Supply 1	Absent	
	FPC 0 Power Supply 2	OK	
	FPC 0 Power Supply 3	OK	
Temp	FPC 0 Intake Temp Sensor	OK	25 degrees C / 77 degrees F
	FPC 0 Exhaust Temp Sensor	OK	35 degrees C / 95 degrees F
	FPC 0 Mezz Temp Sensor 0	OK	25 degrees C / 77 degrees F
	FPC 0 Mezz Temp Sensor 1	OK	34 degrees C / 93 degrees F
	FPC 0 PE2 Temp Sensor	OK	34 degrees C / 93 degrees F
	FPC 0 PE1 Temp Sensor	OK	32 degrees C / 89 degrees F
	FPC 0 PF0 Temp Sensor	OK	40 degrees C / 104 degrees F
	FPC 0 PE0 Temp Sensor	OK	33 degrees C / 91 degrees F
	FPC 0 PE5 Temp Sensor	OK	34 degrees C / 93 degrees F
	FPC 0 PE4 Temp Sensor	OK	34 degrees C / 93 degrees F
	FPC 0 PF1 Temp Sensor	OK	41 degrees C / 105 degrees F
	FPC 0 PE3 Temp Sensor	OK	36 degrees C / 96 degrees F
	FPC 0 CPU Die Temp Sensor	OK	40 degrees C / 104 degrees F
	FPC 0 OCX0 Temp Sensor	OK	37 degrees C / 98 degrees F
Fans	FPC 0 Fan Tray 0	OK	Spinning at normal speed
	FPC 0 Fan Tray 1	OK	Spinning at normal speed
	FPC 0 Fan Tray 2	OK	Spinning at normal speed

show chassis environment (PTX10008 Router)

```
user@host> show chassis environment
```

Class	Item	Status	Measurement
	Routing Engine 0 CPU	OK	40 degrees C / 104 degrees F
	Routing Engine 1 CPU	OK	40 degrees C / 104 degrees F
Temp	CB 0 Intake Temp Sensor	OK	29 degrees C / 84 degrees F
	CB 0 Exhaust Temp Sensor	OK	33 degrees C / 91 degrees F
	CB 1 Intake Temp Sensor	OK	28 degrees C / 82 degrees F
	CB 1 Exhaust Temp Sensor	OK	32 degrees C / 89 degrees F
	FPC 0 Intake-A Temp Sensor	OK	38 degrees C / 100 degrees F
	FPC 0 Intake-B Temp Sensor	OK	34 degrees C / 93 degrees F
	FPC 0 Exhaust-A Temp Sensor	OK	36 degrees C / 96 degrees F
	FPC 0 Exhaust-B Temp Sensor	OK	37 degrees C / 98 degrees F
	FPC 0 Exhaust-C Temp Sensor	OK	40 degrees C / 104 degrees F
	FPC 0 PE0 Temp Sensor	OK	40 degrees C / 104 degrees F
	FPC 0 PE1 Temp Sensor	OK	42 degrees C / 107 degrees F
	FPC 0 PE2 Temp Sensor	OK	44 degrees C / 111 degrees F
	FPC 0 LCPU Temp Sensor	OK	41 degrees C / 105 degrees F

FPC 1 Intake-A Temp Sensor	OK	37 degrees C / 98 degrees F
FPC 1 Intake-B Temp Sensor	OK	33 degrees C / 91 degrees F
FPC 1 Exhaust-A Temp Sensor	OK	37 degrees C / 98 degrees F
FPC 1 Exhaust-B Temp Sensor	OK	38 degrees C / 100 degrees F
FPC 1 Exhaust-C Temp Sensor	OK	40 degrees C / 104 degrees F
FPC 1 PE0 Temp Sensor	OK	41 degrees C / 105 degrees F
FPC 1 PE1 Temp Sensor	OK	41 degrees C / 105 degrees F
FPC 1 PE2 Temp Sensor	OK	45 degrees C / 113 degrees F
FPC 1 LCPU Temp Sensor	OK	40 degrees C / 104 degrees F
FPC 2 Intake-A Temp Sensor	OK	44 degrees C / 111 degrees F
FPC 2 Intake-B Temp Sensor	OK	30 degrees C / 86 degrees F
FPC 2 Exhaust-A Temp Sensor	OK	52 degrees C / 125 degrees F
FPC 2 Exhaust-B Temp Sensor	OK	54 degrees C / 129 degrees F
FPC 2 Exhaust-C Temp Sensor	OK	52 degrees C / 125 degrees F
FPC 2 PE0 Temp Sensor	OK	49 degrees C / 120 degrees F
FPC 2 PE1 Temp Sensor	OK	59 degrees C / 138 degrees F
FPC 2 PE2 Temp Sensor	OK	49 degrees C / 120 degrees F
FPC 2 PE3 Temp Sensor	OK	60 degrees C / 140 degrees F
FPC 2 PE4 Temp Sensor	OK	49 degrees C / 120 degrees F
FPC 2 PE5 Temp Sensor	OK	63 degrees C / 145 degrees F
FPC 2 LCPU Temp Sensor	OK	47 degrees C / 116 degrees F
FPC 3 Intake-A Temp Sensor	OK	42 degrees C / 107 degrees F
FPC 3 Intake-B Temp Sensor	OK	30 degrees C / 86 degrees F
FPC 3 Exhaust-A Temp Sensor	OK	46 degrees C / 114 degrees F
FPC 3 Exhaust-B Temp Sensor	OK	48 degrees C / 118 degrees F
FPC 3 Exhaust-C Temp Sensor	OK	47 degrees C / 116 degrees F
FPC 3 PE0 Temp Sensor	OK	47 degrees C / 116 degrees F
FPC 3 PE1 Temp Sensor	OK	53 degrees C / 127 degrees F
FPC 3 PE2 Temp Sensor	OK	46 degrees C / 114 degrees F
FPC 3 PE3 Temp Sensor	OK	53 degrees C / 127 degrees F
FPC 3 PE4 Temp Sensor	OK	48 degrees C / 118 degrees F
FPC 3 PE5 Temp Sensor	OK	57 degrees C / 134 degrees F
FPC 3 LCPU Temp Sensor	OK	47 degrees C / 116 degrees F
FPC 5 Intake-A Temp Sensor	Failed	
FPC 5 Intake-B Temp Sensor	Failed	
FPC 5 Exhaust-A Temp Sensor	OK	40 degrees C / 104 degrees F
FPC 5 Exhaust-B Temp Sensor	OK	40 degrees C / 104 degrees F
FPC 5 Exhaust-C Temp Sensor	OK	41 degrees C / 105 degrees F
FPC 5 PE0 Temp Sensor	OK	46 degrees C / 114 degrees F
FPC 5 PE1 Temp Sensor	OK	48 degrees C / 118 degrees F
FPC 5 PE2 Temp Sensor	OK	51 degrees C / 123 degrees F
FPC 5 LCPU Temp Sensor	Failed	
FPC 6 Intake-A Temp Sensor	OK	40 degrees C / 104 degrees F

FPC 6 Intake-B Temp Sensor	OK	36 degrees C / 96 degrees F
FPC 6 Exhaust-A Temp Sensor	OK	39 degrees C / 102 degrees F
FPC 6 Exhaust-B Temp Sensor	OK	39 degrees C / 102 degrees F
FPC 6 Exhaust-C Temp Sensor	OK	39 degrees C / 102 degrees F
FPC 6 PE0 Temp Sensor	OK	44 degrees C / 111 degrees F
FPC 6 PE1 Temp Sensor	OK	45 degrees C / 113 degrees F
FPC 6 PE2 Temp Sensor	OK	50 degrees C / 122 degrees F
FPC 6 LCPU Temp Sensor	OK	40 degrees C / 104 degrees F
SIB 0 Intake-A Temp Sensor	OK	37 degrees C / 98 degrees F
SIB 0 Intake-B Temp Sensor	OK	30 degrees C / 86 degrees F
SIB 0 Exhaust-A Temp Sensor	OK	33 degrees C / 91 degrees F
SIB 0 Exhaust-B Temp Sensor	OK	38 degrees C / 100 degrees F
SIB 0 PF0 Temp Sensor	OK	46 degrees C / 114 degrees F
SIB 0 PF1 Temp Sensor	OK	39 degrees C / 102 degrees F
SIB 1 Intake-A Temp Sensor	OK	43 degrees C / 109 degrees F
SIB 1 Intake-B Temp Sensor	OK	34 degrees C / 93 degrees F
SIB 1 Exhaust-A Temp Sensor	OK	36 degrees C / 96 degrees F
SIB 1 Exhaust-B Temp Sensor	OK	44 degrees C / 111 degrees F
SIB 1 PF0 Temp Sensor	OK	54 degrees C / 129 degrees F
SIB 1 PF1 Temp Sensor	OK	41 degrees C / 105 degrees F
SIB 2 Intake-A Temp Sensor	OK	46 degrees C / 114 degrees F
SIB 2 Intake-B Temp Sensor	OK	35 degrees C / 95 degrees F
SIB 2 Exhaust-A Temp Sensor	OK	37 degrees C / 98 degrees F
SIB 2 Exhaust-B Temp Sensor	OK	47 degrees C / 116 degrees F
SIB 2 PF0 Temp Sensor	OK	55 degrees C / 131 degrees F
SIB 2 PF1 Temp Sensor	OK	42 degrees C / 107 degrees F
SIB 3 Intake-A Temp Sensor	OK	45 degrees C / 113 degrees F
SIB 3 Intake-B Temp Sensor	OK	35 degrees C / 95 degrees F
SIB 3 Exhaust-A Temp Sensor	OK	36 degrees C / 96 degrees F
SIB 3 Exhaust-B Temp Sensor	OK	45 degrees C / 113 degrees F
SIB 3 PF0 Temp Sensor	OK	54 degrees C / 129 degrees F
SIB 3 PF1 Temp Sensor	OK	42 degrees C / 107 degrees F
SIB 4 Intake-A Temp Sensor	OK	46 degrees C / 114 degrees F
SIB 4 Intake-B Temp Sensor	OK	34 degrees C / 93 degrees F
SIB 4 Exhaust-A Temp Sensor	OK	36 degrees C / 96 degrees F
SIB 4 Exhaust-B Temp Sensor	OK	46 degrees C / 114 degrees F
SIB 4 PF0 Temp Sensor	OK	54 degrees C / 129 degrees F
SIB 4 PF1 Temp Sensor	OK	41 degrees C / 105 degrees F
SIB 5 Intake-A Temp Sensor	OK	38 degrees C / 100 degrees F
SIB 5 Intake-B Temp Sensor	OK	31 degrees C / 87 degrees F
SIB 5 Exhaust-A Temp Sensor	OK	34 degrees C / 93 degrees F
SIB 5 Exhaust-B Temp Sensor	OK	39 degrees C / 102 degrees F
SIB 5 PF0 Temp Sensor	OK	44 degrees C / 111 degrees F

	SIB 5 PF1 Temp Sensor	OK	42 degrees C / 107 degrees F
Power	Power Supply 0	OK	
	Power Supply 1	OK	
	Power Supply 2	OK	
	Power Supply 3	OK	
	Power Supply 4	Check	
	Power Supply 5	OK	
Fans	Fan Tray 0 Fan 0	OK	Spinning at normal speed
	Fan Tray 0 Fan 1	OK	Spinning at normal speed
	Fan Tray 0 Fan 2	OK	Spinning at normal speed
	Fan Tray 0 Fan 3	OK	Spinning at normal speed
	Fan Tray 0 Fan 4	Failed	
	Fan Tray 0 Fan 5	Failed	
	Fan Tray 0 Fan 6	OK	Spinning at normal speed
	Fan Tray 0 Fan 7	OK	Spinning at normal speed
	Fan Tray 0 Fan 8	OK	Spinning at normal speed
	Fan Tray 0 Fan 9	OK	Spinning at normal speed
	Fan Tray 0 Fan 10	OK	Spinning at normal speed
	Fan Tray 1 Fan 0	OK	Spinning at normal speed
	Fan Tray 1 Fan 1	OK	Spinning at normal speed
	Fan Tray 1 Fan 2	OK	Spinning at normal speed
	Fan Tray 1 Fan 3	OK	Spinning at normal speed
	Fan Tray 1 Fan 4	OK	Spinning at normal speed
	Fan Tray 1 Fan 5	OK	Spinning at normal speed
	Fan Tray 1 Fan 6	OK	Spinning at normal speed
	Fan Tray 1 Fan 7	OK	Spinning at normal speed
	Fan Tray 1 Fan 8	OK	Spinning at normal speed
	Fan Tray 1 Fan 9	OK	Spinning at normal speed
	Fan Tray 1 Fan 10	OK	Spinning at normal speed

show chassis environment (PTX10016 Router)

```
user@host> show chassis environment
```

Class	Item	Status	Measurement
	Routing Engine 0 CPU	OK	34 degrees C / 93 degrees F
	Routing Engine 1 CPU	OK	34 degrees C / 93 degrees F
Temp	CB 0 Intake Temp Sensor	OK	20 degrees C / 68 degrees F
	CB 0 Exhaust Temp Sensor	OK	24 degrees C / 75 degrees F
	CB 1 Intake Temp Sensor	OK	20 degrees C / 68 degrees F
	CB 1 Exhaust Temp Sensor	OK	23 degrees C / 73 degrees F
	FPC 1 Intake-A Temp Sensor	OK	37 degrees C / 98 degrees F

FPC 1 Intake-B Temp Sensor	OK	32 degrees C / 89 degrees F
FPC 1 Exhaust-A Temp Sensor	OK	37 degrees C / 98 degrees F
FPC 1 Exhaust-B Temp Sensor	OK	36 degrees C / 96 degrees F
FPC 1 Exhaust-C Temp Sensor	OK	36 degrees C / 96 degrees F
FPC 1 PE0 Temp Sensor	OK	45 degrees C / 113 degrees F
FPC 1 PE1 Temp Sensor	OK	46 degrees C / 114 degrees F
FPC 1 PE2 Temp Sensor	OK	54 degrees C / 129 degrees F
FPC 1 LCPU Temp Sensor	OK	35 degrees C / 95 degrees F
FPC 3 Intake-A Temp Sensor	OK	35 degrees C / 95 degrees F
FPC 3 Intake-B Temp Sensor	OK	31 degrees C / 87 degrees F
FPC 3 Exhaust-A Temp Sensor	OK	36 degrees C / 96 degrees F
FPC 3 Exhaust-B Temp Sensor	OK	35 degrees C / 95 degrees F
FPC 3 Exhaust-C Temp Sensor	OK	33 degrees C / 91 degrees F
FPC 3 PE0 Temp Sensor	OK	43 degrees C / 109 degrees F
FPC 3 PE1 Temp Sensor	OK	45 degrees C / 113 degrees F
FPC 3 PE2 Temp Sensor	OK	49 degrees C / 120 degrees F
FPC 3 LCPU Temp Sensor	OK	35 degrees C / 95 degrees F
FPC 6 Intake-A Temp Sensor	OK	34 degrees C / 93 degrees F
FPC 6 Intake-B Temp Sensor	OK	31 degrees C / 87 degrees F
FPC 6 Exhaust-A Temp Sensor	OK	35 degrees C / 95 degrees F
FPC 6 Exhaust-B Temp Sensor	OK	35 degrees C / 95 degrees F
FPC 6 Exhaust-C Temp Sensor	OK	35 degrees C / 95 degrees F
FPC 6 PE0 Temp Sensor	OK	43 degrees C / 109 degrees F
FPC 6 PE1 Temp Sensor	OK	43 degrees C / 109 degrees F
FPC 6 PE2 Temp Sensor	OK	47 degrees C / 116 degrees F
FPC 6 LCPU Temp Sensor	OK	35 degrees C / 95 degrees F
FPC 8 Intake-A Temp Sensor	OK	34 degrees C / 93 degrees F
FPC 8 Intake-B Temp Sensor	OK	31 degrees C / 87 degrees F
FPC 8 Exhaust-A Temp Sensor	OK	37 degrees C / 98 degrees F
FPC 8 Exhaust-B Temp Sensor	OK	37 degrees C / 98 degrees F
FPC 8 Exhaust-C Temp Sensor	OK	38 degrees C / 100 degrees F
FPC 8 PE0 Temp Sensor	OK	42 degrees C / 107 degrees F
FPC 8 PE1 Temp Sensor	OK	44 degrees C / 111 degrees F
FPC 8 PE2 Temp Sensor	OK	47 degrees C / 116 degrees F
FPC 8 LCPU Temp Sensor	OK	33 degrees C / 91 degrees F
FPC 9 Intake-A Temp Sensor	OK	44 degrees C / 111 degrees F
FPC 9 Intake-B Temp Sensor	OK	28 degrees C / 82 degrees F
FPC 9 Exhaust-A Temp Sensor	OK	51 degrees C / 123 degrees F
FPC 9 Exhaust-B Temp Sensor	OK	52 degrees C / 125 degrees F
FPC 9 Exhaust-C Temp Sensor	OK	48 degrees C / 118 degrees F
FPC 9 PE0 Temp Sensor	OK	52 degrees C / 125 degrees F
FPC 9 PE1 Temp Sensor	OK	66 degrees C / 150 degrees F
FPC 9 PE2 Temp Sensor	OK	50 degrees C / 122 degrees F

	FPC 9 PE3 Temp Sensor	OK	65 degrees C / 149 degrees F
	FPC 9 PE4 Temp Sensor	OK	51 degrees C / 123 degrees F
	FPC 9 PE5 Temp Sensor	OK	68 degrees C / 154 degrees F
	FPC 9 LCPU Temp Sensor	OK	46 degrees C / 114 degrees F
Power	Power Supply 0	OK	22 degrees C / 71 degrees F
	Power Supply 1	OK	23 degrees C / 73 degrees F
	Power Supply 2	OK	23 degrees C / 73 degrees F
	Power Supply 3	OK	21 degrees C / 69 degrees F
	Power Supply 4	OK	22 degrees C / 71 degrees F
	Power Supply 5	OK	25 degrees C / 77 degrees F
	Power Supply 6	OK	21 degrees C / 69 degrees F
	Power Supply 7	Absent	
	Power Supply 8	Absent	
	Power Supply 9	Absent	
Fans	Fan Tray 0 Fan 0	OK	Spinning at normal speed
	Fan Tray 0 Fan 1	OK	Spinning at normal speed
	Fan Tray 0 Fan 2	OK	Spinning at normal speed
	Fan Tray 0 Fan 3	OK	Spinning at normal speed
	Fan Tray 0 Fan 4	OK	Spinning at normal speed
	Fan Tray 0 Fan 5	OK	Spinning at normal speed
	Fan Tray 0 Fan 6	OK	Spinning at normal speed
	Fan Tray 0 Fan 7	OK	Spinning at normal speed
	Fan Tray 0 Fan 8	OK	Spinning at normal speed
	Fan Tray 0 Fan 9	OK	Spinning at normal speed
	Fan Tray 0 Fan 10	OK	Spinning at normal speed
	Fan Tray 0 Fan 11	OK	Spinning at normal speed
	Fan Tray 0 Fan 12	OK	Spinning at normal speed
	Fan Tray 0 Fan 13	OK	Spinning at normal speed
	Fan Tray 0 Fan 14	OK	Spinning at normal speed
	Fan Tray 0 Fan 15	OK	Spinning at normal speed
	Fan Tray 0 Fan 16	OK	Spinning at normal speed
	Fan Tray 0 Fan 17	OK	Spinning at normal speed
	Fan Tray 0 Fan 18	OK	Spinning at normal speed
	Fan Tray 0 Fan 19	OK	Spinning at normal speed
	Fan Tray 0 Fan 20	OK	Spinning at normal speed
	Fan Tray 1 Fan 0	OK	Spinning at normal speed
	Fan Tray 1 Fan 1	OK	Spinning at normal speed
	Fan Tray 1 Fan 2	OK	Spinning at normal speed
	Fan Tray 1 Fan 3	OK	Spinning at normal speed
	Fan Tray 1 Fan 4	OK	Spinning at normal speed
	Fan Tray 1 Fan 5	OK	Spinning at normal speed
	Fan Tray 1 Fan 6	OK	Spinning at normal speed
	Fan Tray 1 Fan 7	OK	Spinning at normal speed

Fan Tray 1 Fan 8	OK	Spinning at normal speed
Fan Tray 1 Fan 9	OK	Spinning at normal speed
Fan Tray 1 Fan 10	OK	Spinning at normal speed
Fan Tray 1 Fan 11	OK	Spinning at normal speed
Fan Tray 1 Fan 12	OK	Spinning at normal speed
Fan Tray 1 Fan 13	OK	Spinning at normal speed
Fan Tray 1 Fan 14	OK	Spinning at normal speed
Fan Tray 1 Fan 15	OK	Spinning at normal speed
Fan Tray 1 Fan 16	OK	Spinning at normal speed
Fan Tray 1 Fan 17	OK	Spinning at normal speed
Fan Tray 1 Fan 18	OK	Spinning at normal speed
Fan Tray 1 Fan 19	OK	Spinning at normal speed
Fan Tray 1 Fan 20	OK	Spinning at normal speed
SIB 0 Intake-A Temp Sensor	OK	20 degrees C / 68 degrees F
SIB 0 Intake-B Temp Sensor	OK	20 degrees C / 68 degrees F
SIB 0 Intake-C Temp Sensor	OK	16 degrees C / 60 degrees F
SIB 0 Exhaust-A Temp Sensor	OK	28 degrees C / 82 degrees F
SIB 0 Exhaust-B Temp Sensor	OK	28 degrees C / 82 degrees F
SIB 0 Exhaust-C Temp Sensor	OK	23 degrees C / 73 degrees F
SIB 0 PF0 Temp Sensor	OK	30 degrees C / 86 degrees F
SIB 0 PF1 Temp Sensor	OK	30 degrees C / 86 degrees F
SIB 0 PF2 Temp Sensor	OK	31 degrees C / 87 degrees F
SIB 0 PF3 Temp Sensor	OK	32 degrees C / 89 degrees F
SIB 0 PF4 Temp Sensor	OK	27 degrees C / 80 degrees F
SIB 0 PF5 Temp Sensor	OK	26 degrees C / 78 degrees F
SIB 1 Intake-A Temp Sensor	OK	22 degrees C / 71 degrees F
SIB 1 Intake-B Temp Sensor	OK	22 degrees C / 71 degrees F
SIB 1 Intake-C Temp Sensor	OK	16 degrees C / 60 degrees F
SIB 1 Exhaust-A Temp Sensor	OK	29 degrees C / 84 degrees F
SIB 1 Exhaust-B Temp Sensor	OK	31 degrees C / 87 degrees F
SIB 1 Exhaust-C Temp Sensor	OK	23 degrees C / 73 degrees F
SIB 1 PF0 Temp Sensor	OK	32 degrees C / 89 degrees F
SIB 1 PF1 Temp Sensor	OK	31 degrees C / 87 degrees F
SIB 1 PF2 Temp Sensor	OK	33 degrees C / 91 degrees F
SIB 1 PF3 Temp Sensor	OK	38 degrees C / 100 degrees F
SIB 1 PF4 Temp Sensor	OK	28 degrees C / 82 degrees F
SIB 1 PF5 Temp Sensor	OK	26 degrees C / 78 degrees F
SIB 2 Intake-A Temp Sensor	OK	24 degrees C / 75 degrees F
SIB 2 Intake-B Temp Sensor	OK	21 degrees C / 69 degrees F
SIB 2 Intake-C Temp Sensor	OK	16 degrees C / 60 degrees F
SIB 2 Exhaust-A Temp Sensor	OK	28 degrees C / 82 degrees F
SIB 2 Exhaust-B Temp Sensor	OK	32 degrees C / 89 degrees F
SIB 2 Exhaust-C Temp Sensor	OK	23 degrees C / 73 degrees F

SIB 2 PF0 Temp Sensor	OK	31 degrees C / 87 degrees F
SIB 2 PF1 Temp Sensor	OK	30 degrees C / 86 degrees F
SIB 2 PF2 Temp Sensor	OK	33 degrees C / 91 degrees F
SIB 2 PF3 Temp Sensor	OK	41 degrees C / 105 degrees F
SIB 2 PF4 Temp Sensor	OK	27 degrees C / 80 degrees F
SIB 2 PF5 Temp Sensor	OK	26 degrees C / 78 degrees F
SIB 3 Intake-A Temp Sensor	OK	22 degrees C / 71 degrees F
SIB 3 Intake-B Temp Sensor	OK	23 degrees C / 73 degrees F
SIB 3 Intake-C Temp Sensor	OK	16 degrees C / 60 degrees F
SIB 3 Exhaust-A Temp Sensor	OK	29 degrees C / 84 degrees F
SIB 3 Exhaust-B Temp Sensor	OK	31 degrees C / 87 degrees F
SIB 3 Exhaust-C Temp Sensor	OK	24 degrees C / 75 degrees F
SIB 3 PF0 Temp Sensor	OK	32 degrees C / 89 degrees F
SIB 3 PF1 Temp Sensor	OK	30 degrees C / 86 degrees F
SIB 3 PF2 Temp Sensor	OK	31 degrees C / 87 degrees F
SIB 3 PF3 Temp Sensor	OK	39 degrees C / 102 degrees F
SIB 3 PF4 Temp Sensor	OK	27 degrees C / 80 degrees F
SIB 3 PF5 Temp Sensor	OK	26 degrees C / 78 degrees F
SIB 4 Intake-A Temp Sensor	OK	22 degrees C / 71 degrees F
SIB 4 Intake-B Temp Sensor	OK	25 degrees C / 77 degrees F
SIB 4 Intake-C Temp Sensor	OK	16 degrees C / 60 degrees F
SIB 4 Exhaust-A Temp Sensor	OK	29 degrees C / 84 degrees F
SIB 4 Exhaust-B Temp Sensor	OK	32 degrees C / 89 degrees F
SIB 4 Exhaust-C Temp Sensor	OK	23 degrees C / 73 degrees F
SIB 4 PF0 Temp Sensor	OK	32 degrees C / 89 degrees F
SIB 4 PF1 Temp Sensor	OK	31 degrees C / 87 degrees F
SIB 4 PF2 Temp Sensor	OK	32 degrees C / 89 degrees F
SIB 4 PF3 Temp Sensor	OK	40 degrees C / 104 degrees F
SIB 4 PF4 Temp Sensor	OK	26 degrees C / 78 degrees F
SIB 4 PF5 Temp Sensor	OK	25 degrees C / 77 degrees F
SIB 5 Intake-A Temp Sensor	OK	21 degrees C / 69 degrees F
SIB 5 Intake-B Temp Sensor	OK	20 degrees C / 68 degrees F
SIB 5 Intake-C Temp Sensor	OK	16 degrees C / 60 degrees F
SIB 5 Exhaust-A Temp Sensor	OK	27 degrees C / 80 degrees F
SIB 5 Exhaust-B Temp Sensor	OK	27 degrees C / 80 degrees F
SIB 5 Exhaust-C Temp Sensor	OK	23 degrees C / 73 degrees F
SIB 5 PF0 Temp Sensor	OK	30 degrees C / 86 degrees F
SIB 5 PF1 Temp Sensor	OK	29 degrees C / 84 degrees F
SIB 5 PF2 Temp Sensor	OK	30 degrees C / 86 degrees F
SIB 5 PF3 Temp Sensor	OK	32 degrees C / 89 degrees F
SIB 5 PF4 Temp Sensor	OK	28 degrees C / 82 degrees F
SIB 5 PF5 Temp Sensor	OK	27 degrees C / 80 degrees F

show chassis environment (ACX2000 Universal Metro Router)

```

user@host> show chassis environment
Class Item                Status    Measurement
  PCB Left                 OK        44 degrees C / 111 degrees F
  SFP+ Xcvr                OK        50 degrees C / 122 degrees F
  FEB                      OK        70 degrees C / 158 degrees F
  PCB Up                   OK        63 degrees C / 145 degrees F
  PCB Mid                  OK        66 degrees C / 150 degrees F
  Telecom Mod              OK        65 degrees C / 149 degrees F
  Routing Engine           OK        54 degrees C / 129 degrees F
  Heater off

```

show chassis environment (ACX4000 Universal Metro Router)

On the ACX4000 router, the MIC output of the `show chassis environment` command varies depending on the number of temperature channels present in the installed MIC.

```

user@host> show chassis environment

Class Item                Status    Measurement
Temp PEM 0                OK        33 degrees C / 91 degrees F
    PEM 1                  Absent
    PCB Bottom             OK        30 degrees C / 86 degrees F
    PCB Middle             OK        34 degrees C / 93 degrees F
    BCM56445               OK        33 degrees C / 91 degrees F
    SFP+ Xcvr              OK        32 degrees C / 89 degrees F
    Fan tray inlet         OK        39 degrees C / 102 degrees F
    Exhaust                OK        30 degrees C / 86 degrees F
    Routing Engine         OK        32 degrees C / 89 degrees F
    Heater off
Pic  PIC 0/0 Channel 0     OK        28 degrees C / 82 degrees F
    PIC 0/0 Channel 1     OK        29 degrees C / 84 degrees F
    PIC 0/0 Channel 2     OK        0 degrees C / 32 degrees F
    PIC 0/0 Channel 3     OK        0 degrees C / 32 degrees F
    PIC 0/0 Channel 4     OK        0 degrees C / 32 degrees F
    PIC 0/0 Channel 5     OK        0 degrees C / 32 degrees F
    PIC 0/0 Channel 6     OK        0 degrees C / 32 degrees F
    PIC 0/0 Channel 7     OK        0 degrees C / 32 degrees F
    PIC 0/0 Channel 8     OK        0 degrees C / 32 degrees F

```

PIC 0/0 Channel 9	OK	0 degrees C / 32 degrees F
PIC 1/0 Channel 0	OK	33 degrees C / 91 degrees F
PIC 1/0 Channel 1	OK	31 degrees C / 87 degrees F
PIC 1/0 Channel 2	OK	30 degrees C / 86 degrees F
PIC 1/0 Channel 3	OK	0 degrees C / 32 degrees F
PIC 1/0 Channel 4	OK	0 degrees C / 32 degrees F
PIC 1/0 Channel 5	OK	0 degrees C / 32 degrees F
PIC 1/0 Channel 6	OK	0 degrees C / 32 degrees F
PIC 1/0 Channel 7	OK	0 degrees C / 32 degrees F
PIC 1/0 Channel 8	OK	0 degrees C / 32 degrees F
PIC 1/1 Channel 0	OK	31 degrees C / 87 degrees F
PIC 1/1 Channel 1	OK	29 degrees C / 84 degrees F
PIC 1/1 Channel 2	OK	28 degrees C / 82 degrees F
PIC 1/1 Channel 3	OK	0 degrees C / 32 degrees F
PIC 1/1 Channel 4	OK	0 degrees C / 32 degrees F
PIC 1/1 Channel 5	OK	0 degrees C / 32 degrees F
PIC 1/1 Channel 6	OK	0 degrees C / 32 degrees F
PIC 1/1 Channel 7	OK	0 degrees C / 32 degrees F
PIC 1/1 Channel 8	OK	0 degrees C / 32 degrees F
Fans Fan 1	OK	Spinning at normal speed
Fans Fan 2	OK	Spinning at normal speed

show chassis environment (ACX5048 Router)

```
user@host> show chassis environment
```

Class	Item	Status	Measurement
Power	FPC 0 Power Supply 0	Absent	
	FPC 0 Power Supply 1	OK	
Temp	FPC 0 Sensor TopMiddle E	OK	23 degrees C / 73 degrees F
	FPC 0 Sensor TopRight C	OK	18 degrees C / 64 degrees F
	FPC 0 Sensor TopLeft C	OK	21 degrees C / 69 degrees F
	FPC 0 Sensor TopRight E	OK	20 degrees C / 68 degrees F
	FPC 0 Sensor CPURight C	OK	23 degrees C / 73 degrees F
	FPC 0 Sensor CPULeft E	OK	22 degrees C / 71 degrees F
	FPC 0 Sensor CPU Die Temp	OK	39 degrees C / 102 degrees F
Fans	FPC 0 Fan Tray 0	OK	Spinning at normal speed
	FPC 0 Fan Tray 1	OK	Spinning at normal speed
	FPC 0 Fan Tray 2	OK	Spinning at normal speed

FPC 0 Fan Tray 3	OK	Spinning at normal speed
FPC 0 Fan Tray 4	OK	Spinning at normal speed

show chassis environment (ACX5096 Router)

```
user@host> show chassis environment
```

Class	Item	Status	Measurement
Power	FPC 0 Power Supply 0	OK	
	FPC 0 Power Supply 1	OK	
Temp	FPC 0 Sensor TopMiddle E	OK	32 degrees C / 89 degrees F
	FPC 0 Sensor TopRight I	OK	29 degrees C / 84 degrees F
	FPC 0 Sensor TopLeft I	OK	23 degrees C / 73 degrees F
	FPC 0 Sensor TopRight E	OK	28 degrees C / 82 degrees F
	FPC 0 Sensor CPURight I	OK	30 degrees C / 86 degrees F
	FPC 0 Sensor CPULeft I	OK	29 degrees C / 84 degrees F
	FPC 0 Sensor Die Temp	OK	46 degrees C / 114 degrees F
	FPC 0 Mezz Temp	OK	23 degrees C / 73 degrees F
Fans	FPC 0 Fan Tray 0	OK	Spinning at normal speed
	FPC 0 Fan Tray 1	OK	Spinning at normal speed
	FPC 0 Fan Tray 2	OK	Spinning at normal speed

show chassis environment (ACX7509)

```
user@host> show chassis environment feb
```

```
FEB 0 status:
```

State	Online	
Q2C0	Die Temperature 0	32 degrees C / 89 degrees F
Q2C0	Die Temperature 1	33 degrees C / 91 degrees F
Q2C0	Die Temperature 2	31 degrees C / 87 degrees F
Q2C0	Die Temperature 3	32 degrees C / 89 degrees F
Q2C0	Die Temperature 4	31 degrees C / 87 degrees F
Q2C0	HBM Temperature	32 degrees C / 89 degrees F
Q2C1	Die Temperature 0	35 degrees C / 95 degrees F
Q2C1	Die Temperature 1	33 degrees C / 91 degrees F
Q2C1	Die Temperature 2	34 degrees C / 93 degrees F
Q2C1	Die Temperature 3	33 degrees C / 91 degrees F
Q2C1	Die Temperature 4	34 degrees C / 93 degrees F
Q2C1	HBM Temperature	33 degrees C / 91 degrees F

Intake Rear Left Temp	28 degrees C / 82 degrees F
PEX8725 PCIe Temp	42 degrees C / 107 degrees F
Intake Rear Right Temp	24 degrees C / 75 degrees F
Exhaust Rear Right Temp	29 degrees C / 84 degrees F
Q2C0 Diode Temp	44 degrees C / 111 degrees F
Exhaust Rear Left Temp	30 degrees C / 86 degrees F
Q2C1 Diode Temp	46 degrees C / 114 degrees F
HotSwap0 Temp	24 degrees C / 75 degrees F
HotSwap1 Temp	25 degrees C / 77 degrees F
FPGA_VDD1V0 Temp	34 degrees C / 93 degrees F
PCI_E_VDD0V9 Temp	41 degrees C / 105 degrees F
J2VDDIO_1P8 Temp	30 degrees C / 86 degrees F
VDD3V3 Temp	28 degrees C / 82 degrees F
VDD5V0 Temp	29 degrees C / 84 degrees F
VDD2V5 Temp	32 degrees C / 89 degrees F
J2TVDD_1P2 Temp	36 degrees C / 96 degrees F
Q2C0-J2HBMVDD0C_1P2 Temp	31 degrees C / 87 degrees F
Q2C1-J2HBMVDD0C_1P2 Temp	34 degrees C / 93 degrees F
Q2C0 Core Rail 1 Temp	34 degrees C / 93 degrees F
Q2C0 Pwr Reg Intrnl Temp	29 degrees C / 84 degrees F
Q2C1 Core Rail 0 Temp	37 degrees C / 98 degrees F
Q2C0 Core Rail 0 Temp	38 degrees C / 100 degrees F
Q2C1 Core Rail 1 Temp	35 degrees C / 95 degrees F
Q2C1 Pwr Reg Intrnl Temp	29 degrees C / 84 degrees F
Power 1	
BIAS3V3	3288 mV
FPGA_VDD1V2	1214 mV
FPGA_VDD3V3	3320 mV
PFE0_J2HBMVDD_2P5	2528 mV
PFE0_J2PHYVDDC_0P88	892 mV
PFE0_J2PLLVD_1P8	1822 mV
PFE1_J2HBMVDD_2P5	2524 mV
PFE1_J2PHYVDDC_0P88	894 mV
PFE1_J2PLLVD_1P8	1824 mV
VDDCLK_3V3	3304 mV
Power 2	
PFE0_J2PLLAVDD_1P8	1794 mV
PFE0_J2PLLVD_0P8	838 mV
PFE1_J2PLLAVDD_1P8	1802 mV
PFE1_J2PLLVD_0P8	836 mV
Power 3	
Hotswap 0, 12V0	11955 mV
Power 4	

```

Hotswap 1, 12V0          11982 mV
Power 5
  PFE0_J2TRVDD_0P8      835 mV
  PFE0_J2VDDC_0P82     820 mV
Power 6
  PFE1_J2TRVDD_0P8      835 mV
  PFE1_J2VDDC_0P82     820 mV
Power 7
  J2VDDIO_1P8          1795 mV
Power 8
  VDD5V0                4961 mV
Power 9
  VDD2V5                2494 mV
Power 10
  VDD3V3                3295 mV
Power 11
  PCIE_VDD0V9           906 mV
Power 12
  J2TVDD_1P2            1274 mV
Power 13
  FPGA_VDD1V0           991 mV
Power 14
  PFE1_J2HBMVDDOC_1P2  1196 mV
Power 15
  PFE0_J2HBMVDDOC_1P2  1196 mV
Bus Revision              19

```

show chassis environment (ACX500 Router)

```
user@host> show chassis environment
```

Class	Item	Status	Measurement
	Power Mod	OK	47 degrees C / 116 degrees F
	BCM54610	OK	46 degrees C / 114 degrees F
	DPLL31404	OK	45 degrees C / 113 degrees F
	CPLD	OK	42 degrees C / 107 degrees F
	1588-FPGA	OK	43 degrees C / 109 degrees F
	NPU	OK	62 degrees C / 143 degrees F
	MAC sensor 1	OK	40 degrees C / 104 degrees F
	MAC sensor 2	OK	38 degrees C / 100 degrees F
	SFP PHY	OK	38 degrees C / 100 degrees F

Combo/RJ45 PHY	OK	37 degrees C / 98 degrees F
SFP sensor 1	OK	35 degrees C / 95 degrees F
SFP sensor 2	OK	33 degrees C / 91 degrees F
SFP sensor 3	OK	32 degrees C / 89 degrees F
Routing Engine	OK	54 degrees C / 129 degrees F
Heater off		

show chassis environment (Junos OS Evolved)

```

user@host> show chassis environment
Class  Item                               Status  Measurement
Power  PSM 0                             OK      26 degrees C / 78 degrees F
       PSM 1                         OK      31 degrees C / 87 degrees F
       PSM 2                         Failed
Temp   CB 0 Intake A Temp Sensor          OK      23 degrees C / 73 degrees F
       CB 0 Intake B Temp Sensor      OK      22 degrees C / 71 degrees F
       CB 0 Exhaust A Temp Sensor      OK      26 degrees C / 78 degrees F
       CB 0 Exhaust B Temp Sensor      OK      29 degrees C / 84 degrees F
       CB 0 Middle Temp Sensor        OK      30 degrees C / 86 degrees F
       CB 1 Intake A Temp Sensor        OK      23 degrees C / 73 degrees F
       CB 1 Intake B Temp Sensor        OK      21 degrees C / 69 degrees F
       CB 1 Exhaust A Temp Sensor      OK      26 degrees C / 78 degrees F
       CB 1 Exhaust B Temp Sensor      OK      29 degrees C / 84 degrees F
       CB 1 Middle Temp Sensor         OK      29 degrees C / 84 degrees F
       Fan Tray 0 Inlet Temp Sensor    OK      24 degrees C / 75 degrees F
       Fan Tray 0 Outlet Temp Sensor   OK      28 degrees C / 82 degrees F
       Fan Tray 1 Inlet Temp Sensor    OK      24 degrees C / 75 degrees F
       Fan Tray 1 Outlet Temp Sensor   OK      28 degrees C / 82 degrees F
       FPC 0 BT-0 Temp Sensor 1        OK      44 degrees C / 111 degrees F
       FPC 0 BT-0 Temp Sensor 0        OK      44 degrees C / 111 degrees F
       FPC 0 BT-1 Temp Sensor 0        OK      45 degrees C / 113 degrees F
       FPC 0 BT-1 Temp Sensor 1        OK      45 degrees C / 113 degrees F

```

Release Information

Command introduced before Junos OS Release 7.4.

sfc option introduced for the TX Matrix Plus router in Junos OS Release 9.6.

monitored option added in Junos OS Release 12.1x48 for PTX Series Packet Transport Routers.

`pem` option introduced in Junos OS Release 12.3 for ACX4000 Universal Metro Routers.

`satellite` option introduced in Junos OS Release 14.2R3.

`all-members`, `local`, and `member` *member-id* options introduced in Junos OS Release 15.1 for MX2010 and MX2020 routers.

RELATED DOCUMENTATION

[show chassis environment adc](#)

[show chassis environment cb](#)

[show chassis environment ccg](#)

[show chassis environment cip](#)

show chassis environment fpc

[show chassis environment fpm](#)

[show chassis environment lcc](#)

[show chassis environment mcs](#)

[show chassis environment monitored](#)

[show chassis environment pcg](#)

[show chassis environment pdu](#)

show chassis environment pem

[show chassis environment psm](#)

[show chassis environment psu](#)

show chassis environment routing-engine

[show chassis environment scg](#)

[show chassis environment sfb](#)

[show chassis environment sib](#)

[show chassis environment sfc](#)

show chassis environment fpc

IN THIS SECTION

- [Syntax | 399](#)
- [Syntax \(TX Matrix and TX Matrix Plus Routers\) | 399](#)
- [Syntax \(MX Series Routers\) | 400](#)
- [Syntax \(MX2010, MX10003, MX204, MX2008, and MX10008, OCX Series, PTX3000, PTX10008 devices and Junos OS Evolved platforms\) | 400](#)
- [Syntax \(MX2020 Universal Routing Platforms\) | 400](#)
- [Syntax \(QFX Series\) | 400](#)
- [Description | 400](#)
- [Options | 401](#)
- [Required Privilege Level | 403](#)
- [Output Fields | 403](#)
- [Sample Output | 405](#)
- [Release Information | 479](#)

Syntax

```
show chassis environment fpc  
<slot>
```

Syntax (TX Matrix and TX Matrix Plus Routers)

```
show chassis environment fpc  
<lcc number>  
<slot>
```

Syntax (MX Series Routers)

```
show chassis environment fpc
<slot>
<all-members>
<local>
<member member-id>
```

Syntax (MX2010, MX10003, MX204, MX2008, and MX10008, OCX Series, PTX3000, PTX10008 devices and Junos OS Evolved platforms)

```
show chassis environment fpc
<slot>
```

Syntax (MX2020 Universal Routing Platforms)

```
show chassis environment fpc
<slot>
<satellite [fpc-slot slot-id |device-alias alias-name]
```

Syntax (QFX Series)

```
show chassis environment fpc
<fpc-slot>
interconnect-device name
```

Description

(M40e, M120, M160, M320, MX Series, T Series routers, EX Series, QFX Series, and PTX Series routers only) Display environmental information about Flexible PIC Concentrators (FPCs).

Options

none	Display environmental information about all FPCs. On a TX Matrix router, display environmental information about all FPCs on the TX Matrix router and its attached T640 routers. On a TX Matrix Plus router, display environmental information about all FPCs on the TX Matrix Plus router and its attached routers.
all-members	(MX Series routers only) (Optional) Display environmental information for the FPCs in all the members of the Virtual Chassis configuration.
interconnect-device <i>name</i>	(QFabric systems only) (Optional) Display chassis environmental information for the Interconnect device.
lcc <i>number</i>	(TX Matrix router and TX Matrix Plus router only) (Optional) Line-card chassis number. Replace <i>number</i> with the following values depending on the LCC configuration: <ul style="list-style-type: none"> • 0 through 3, when T640 routers are connected to a TX Matrix router in a routing matrix. • 0 through 3, when T1600 routers are connected to a TX Matrix Plus router in a routing matrix. • 0 through 7, when T1600 routers are connected to a TX Matrix Plus router with 3D SIBs in a routing matrix. • 0, 2, 4, or 6, when T4000 routers are connected to a TX Matrix Plus router with 3D SIBs in a routing matrix.
local	(MX Series routers only) (Optional) Display environmental information for the FPCs in the local Virtual Chassis member.
member <i>member-id</i>	(MX Series routers only) (Optional) Display environmental information for the FPCs in the specified member of the Virtual Chassis configuration. Replace <i>member-id</i> with a value of 0 or 1.
satellite [fpc-slot <i>slot-id</i> device-alias <i>alias-name</i>]	(Junos Fusion only)(Optional) Display environmental information for the FPCs in the specified satellite device in a Junos Fusion, or for all satellite devices in the Junos Fusion if no satellite devices are specified.
<i>slot</i> or <i>fpc-slot</i>	(Optional) Display environmental information about an individual FPC:

- (TX Matrix and TX Matrix Plus routers only) On a TX Matrix router, if you specify the number of the T640 router by using only the `lcc number` option (the recommended method), replace `slot` with a value from 0 through 7. Similarly, on a TX Matrix Plus router, if you specify the number of the router by using only the `lcc number` option (the recommended method), replace `slot` with a value from 0 through 7. Otherwise, replace `slot` with a value from 0 through 31. For example, the following commands have the same result:

```
user@host> show chassis environment fpc 1 lcc 1
user@host> show chassis environment fpc 9
```

- M120 router—Replace `slot` with a value from 0 through 5.
- MX240 router—Replace `slot` with a value from 0 through 2.
- MX480 router—Replace `slot` with a value from 0 through 5.
- MX960 router—Replace `slot` with a value from 0 through 11.
- MX2010 router—Replace `slot` with a value from 0 through 9.
- MX2020 router—Replace `slot` with a value from 0 through 19.
- MX2008 router—Replace `slot` with a value from 0 through 9.
- Other routers—Replace `slot` with a value from 0 through 7.
- EX Series switches:
 - EX3200 switches and EX4200 standalone switches—Replace `slot` with 0.
 - EX4200 switches in a Virtual Chassis configuration—Replace `slot` with a value from 0 through 9 (switch's member ID).
 - EX6210 switches—Replace `slot` with a value from 0 through 3 (line card only), 4 or 5 (line card or Switch Fabric and Routing Engine (SRE) module), or 6 through 9 (line card only).
 - EX8208 switches—Replace `slot` with a value from 0 through 7 (line card).
 - EX8216 switches—Replace `slot` with a value from 0 through 15 (line card).
- QFX3500 switches —Replace `fpc-slot` with 0 through 15.
- PTX5000 Packet Transport Router—Replace `fpc-slot` with 0 through 7.

- PTX3000 Packet Transport Router—Replace *fpc-slot* with 0 through 15.

Required Privilege Level

view

Output Fields

[Table 15 on page 403](#) lists the output fields for the `show chassis environment fpc` command. Output fields are listed in the approximate order in which they appear.

Table 15: show chassis environment fpc Output Fields

Field Name	Field Description
State	<p>Status of the FPC:</p> <ul style="list-style-type: none"> • Unknown—FPC is not detected by the router. • Empty—No FPC is present. • Present—FPC is detected by the chassis daemon but is either not supported by the current version of the Junos OS, or the FPC is coming up but not yet online. • Ready—FPC is in intermediate or transition state. • Announce online—Intermediate state during which the FPC is coming up but not yet online, and the chassis manager acknowledges the chassisd FPC online initiative. • Online—FPC is online and running. • Offline—FPC is powered down. • Diagnostics—FPC is set to operate in diagnostics mode.
Temperature	(M40e and M160 routers and QFX Series only) Temperature of the air flowing past the FPC.
PMB Temperature	<p>(PTX Series only) Temperature of the air flowing past the PMB (bottom of the FPC).</p> <p>The PTX5000 Packet Transport Router with FPC2-PTX-P1A include multiple temperatures for PMB (TEMP0 and TEMP1).</p>

Table 15: show chassis environment fpc Output Fields (Continued)

Field Name	Field Description
PMB CPU Temperature	(PTX5000 Packet Transport Router with FPC2-PTX-P1A only) Temperature of the air flowing past the PMB CPU.
Temperature Intake	(M320 routers, MX2010 routers, MX2020 routers, MX2008 routers, and PTX Series only) Temperature of the air flowing into the chassis.
Temperature Top	(T Series routers only) Temperature of the air flowing past the top of the FPC.
Temperature Exhaust	(M120 and M320 routers, MX2010 routers, MX2020 routers, MX2008 routers, and PTX Series only) Temperature of the air flowing out of the chassis. The PTX Series Packet Transport Routers, and the MX2010, MX2020, and MX2008 routers include exhaust temperatures for multiple zones (Exhaust A and Exhaust B).
Temperature Bottom	(T Series routers only) Temperature of the air flowing past the bottom of the FPC.
TL <i>n</i> Temperature	(PTX Series only) Temperature of the air flowing past the specified TL area of the packet forwarding engine (PFE) on the FPC.
TQ <i>n</i> Temperature	(PTX Series only) Temperature of the air flowing past the specified TQ area of the packet forwarding engine (PFE) on the FPC.
Temperature MMBO	(T640 router only) Temperature of the air flowing past the type 3 FPC.
Temperature MMB1	(M320 and T Series routers only) Temperature of the air flowing past the type 1, type 2, and type 3 FPC.
Power	Information about the voltage supplied to the FPC. The left column displays the required power, in volts. The right column displays the measured power, in millivolts.
CMB Revision or BUS revision	Revision level of the chassis management bus device (M Series router) or bus (T Series routers).

Sample Output

show chassis environment fpc (M120 Router)

```

user@host> show chassis environment fpc
FPC 2 status:
  State                Online
  Temperature Exhaust A 32 degrees C / 89 degrees F
  Temperature Exhaust B 31 degrees C / 87 degrees F
  Power A-Board
    1.2 V                1202 mV
    1.5 V                1508 mV
    1.8 V                1798 mV
    2.5 V                2507 mV
    3.3 V                3351 mV
    5.0 V                4995 mV
    3.3 V bias           3296 mV
    1.2 V Rocket IO     1205 mV
    1.5 V Rocket IO     1501 mV
  I2C Slave Revision    12
FPC 3 status:
  State                Online
  Temperature Exhaust A 31 degrees C / 87 degrees F
  Temperature Exhaust B 33 degrees C / 91 degrees F
  Power A-Board
    1.2 V                1211 mV
    1.5 V                1501 mV
    1.8 V                1798 mV
    2.5 V                2471 mV
    3.3 V                3293 mV
    5.0 V                4930 mV
    3.3 V bias           3296 mV
    1.2 V Rocket IO     1205 mV
    1.5 V Rocket IO     1501 mV
  Power B-Board
    1.2 V                1214 mV
    1.5 V                1501 mV
    2.5 V                2471 mV
    3.3 V                3300 mV
    5.0 V                4943 mV
    3.3 V bias           3296 mV
    1.2 V Rocket IO     1205 mV

```



```

    1.5 V Rocket IO      1501 mV
    I2C Slave Revision   12
FPC 4 status:
  State                  Online
  Temperature Exhaust A 32 degrees C / 89 degrees F
  Temperature Exhaust B 30 degrees C / 86 degrees F
Power A-Board
  1.2 V                  1195 mV
  1.5 V                  1504 mV
  1.8 V                  1801 mV
  2.5 V                  2504 mV
  3.3 V                  3293 mV
  5.0 V                  4917 mV
  3.3 V bias            3296 mV
  1.2 V Rocket IO      1202 mV
  1.5 V Rocket IO      1492 mV
  I2C Slave Revision   12

```

show chassis environment fpc (M160 Router)

```

user@host> show chassis environment fpc
FPC 0 status:
  State                  Online
  Temperature            42 degrees C / 107 degrees F
Power:
  1.5 V                  1500 mV
  2.5 V                  2509 mV
  3.3 V                  3308 mV
  5.0 V                  4991 mV
  5.0 V bias            4952 mV
  8.0 V bias            8307 mV
  CMB Revision          12
FPC 1 status:
  State                  Online
  Temperature            45 degrees C / 113 degrees F
Power:
  1.5 V                  1498 mV
  2.5 V                  2501 mV
  3.3 V                  3319 mV
  5.0 V                  5020 mV
  5.0 V bias            5025 mV

```

```

8.0 V bias      8307 mV
CMB Revision    12

```

show chassis environment fpc (M320 Router)

```

user@host> show chassis environment fpc
FPC 0 status:
  State                Online
  Temperature Intake    27 degrees C / 80 degrees F
  Temperature Exhaust   38 degrees C / 100 degrees F
  Temperature MMB1     31 degrees C / 87 degrees F
  Power:
    1.5 V                1487 mV
    1.5 V *              1494 mV
    1.8 V                1821 mV
    2.5 V                2533 mV
    3.3 V                3323 mV
    5.0 V                5028 mV
    3.3 V bias          3296 mV
    5.0 V bias          4984 mV
  CMB Revision          16
FPC 1 status:
  State                Online
  Temperature Intake    27 degrees C / 80 degrees F
  Temperature Exhaust   37 degrees C / 98 degrees F
  Temperature MMB1     32 degrees C / 89 degrees F
  Power:
    1.5 V                1504 mV
    1.5 V *              1499 mV
    1.8 V                1820 mV
    2.5 V                2529 mV
    3.3 V                3328 mV
    5.0 V                5013 mV
    3.3 V bias          3294 mV
    5.0 V bias          4984 mV
  CMB Revision          16
FPC 2 status:
  State                Online
  Temperature Intake    28 degrees C / 82 degrees F
  Temperature Exhaust   38 degrees C / 100 degrees F
  Temperature MMB1     32 degrees C / 89 degrees F

```

```

Power:
  1.5 V          1498 mV
  1.5 V *       1487 mV
  1.8 V          1816 mV
  2.5 V          2531 mV
  3.3 V          3324 mV
  5.0 V          5025 mV
  3.3 V bias    3277 mV
  5.0 V bias    5013 mV
CMB Revision    17
FPC 3 status:
...

```

show chassis environment fpc (MX2020 Router)

```

user@host> show chassis environment fpc
FPC 0 status:
State          Online
Temperature Intake  41 degrees C / 105 degrees F
Temperature Exhaust A  48 degrees C / 118 degrees F
Temperature Exhaust B  60 degrees C / 140 degrees F
Temperature LU 0 TSen  56 degrees C / 132 degrees F
Temperature LU 0 Chip  59 degrees C / 138 degrees F
Temperature LU 1 TSen  56 degrees C / 132 degrees F
Temperature LU 1 Chip  61 degrees C / 141 degrees F
Temperature LU 2 TSen  56 degrees C / 132 degrees F
Temperature LU 2 Chip  52 degrees C / 125 degrees F
Temperature LU 3 TSen  56 degrees C / 132 degrees F
Temperature LU 3 Chip  52 degrees C / 125 degrees F
Temperature MQ 0 TSen  49 degrees C / 120 degrees F
Temperature MQ 0 Chip  49 degrees C / 120 degrees F
Temperature MQ 1 TSen  49 degrees C / 120 degrees F
Temperature MQ 1 Chip  52 degrees C / 125 degrees F
Temperature MQ 2 TSen  49 degrees C / 120 degrees F
Temperature MQ 2 Chip  45 degrees C / 113 degrees F
Temperature MQ 3 TSen  49 degrees C / 120 degrees F
Temperature MQ 3 Chip  46 degrees C / 114 degrees F
Power
AS-BIAS3V3-z12105    3299 mV
AS-VDD1V8-z12006    1807 mV
AS-VDD2V5-z12006    2512 mV

```

AS-AVDD1V0-z12004	997 mV
AS-PCIE_1V0-z12004	996 mV
AS-VDD3V3-z12004	3294 mV
AS-VDD_1V5A-z12004	1501 mV
AS-VDD_1V5B-z12004	1498 mV
AS-LU0_1V0-z12004	998 mV
AS-LU1_1V0-z12004	1002 mV
AS-MQ0_1V0-z12004	999 mV
AS-MQ1_1V0-z12004	994 mV
AS-LU2_1V0-z12004	1000 mV
AS-LU3_1V0-z12004	998 mV
AS-MQ2_1V0-z12004	1002 mV
AS-MQ3_1V0-z12004	999 mV
AS-PMB_1V1-z12006	1096 mV
I2C Slave Revision	68
FPC 1 status:	
State	Online
Temperature Intake	39 degrees C / 102 degrees F
Temperature Exhaust A	48 degrees C / 118 degrees F
Temperature Exhaust B	55 degrees C / 131 degrees F
Temperature LU 0 TSen	52 degrees C / 125 degrees F
Temperature LU 0 Chip	54 degrees C / 129 degrees F
Temperature LU 1 TSen	52 degrees C / 125 degrees F
Temperature LU 1 Chip	56 degrees C / 132 degrees F
Temperature LU 2 TSen	52 degrees C / 125 degrees F
Temperature LU 2 Chip	49 degrees C / 120 degrees F
Temperature LU 3 TSen	52 degrees C / 125 degrees F
Temperature LU 3 Chip	50 degrees C / 122 degrees F
Temperature MQ 0 TSen	48 degrees C / 118 degrees F
Temperature MQ 0 Chip	48 degrees C / 118 degrees F
Temperature MQ 1 TSen	48 degrees C / 118 degrees F
Temperature MQ 1 Chip	51 degrees C / 123 degrees F
Temperature MQ 2 TSen	48 degrees C / 118 degrees F
Temperature MQ 2 Chip	45 degrees C / 113 degrees F
Temperature MQ 3 TSen	48 degrees C / 118 degrees F
Temperature MQ 3 Chip	45 degrees C / 113 degrees F
Power	
AS-BIAS3V3-z12105	3291 mV
AS-VDD1V8-z12006	1786 mV
AS-VDD2V5-z12006	2496 mV
AS-AVDD1V0-z12004	1000 mV
AS-PCIE_1V0-z12004	1000 mV
AS-VDD3V3-z12004	3294 mV

```

AS-VDD_1V5A-z12004      1500 mV
AS-VDD_1V5B-z12004      1498 mV
AS-LU0_1V0-z12004       1003 mV
AS-LU1_1V0-z12004       1000 mV
AS-MQ0_1V0-z12004       1000 mV
AS-MQ1_1V0-z12004        995 mV
AS-LU2_1V0-z12004       1002 mV
AS-LU3_1V0-z12004        997 mV
AS-MQ2_1V0-z12004       1000 mV
AS-MQ3_1V0-z12004        998 mV
AS-PMB_1V1-z12006       1096 mV
I2C Slave Revision      68
FPC 2 status:
State                    Online
Temperature Intake       39 degrees C / 102 degrees F
Temperature Exhaust A    48 degrees C / 118 degrees F
Temperature Exhaust B    58 degrees C / 136 degrees F
Temperature LU 0 TSen    55 degrees C / 131 degrees F
Temperature LU 0 Chip    57 degrees C / 134 degrees F
Temperature LU 1 TSen    55 degrees C / 131 degrees F
Temperature LU 1 Chip    63 degrees C / 145 degrees F
Temperature LU 2 TSen    55 degrees C / 131 degrees F
Temperature LU 2 Chip    51 degrees C / 123 degrees F
Temperature LU 3 TSen    55 degrees C / 131 degrees F
Temperature LU 3 Chip    52 degrees C / 125 degrees F
Temperature MQ 0 TSen    48 degrees C / 118 degrees F
Temperature MQ 0 Chip    50 degrees C / 122 degrees F
Temperature MQ 1 TSen    48 degrees C / 118 degrees F
Temperature MQ 1 Chip    52 degrees C / 125 degrees F
Temperature MQ 2 TSen    48 degrees C / 118 degrees F
Temperature MQ 2 Chip    47 degrees C / 116 degrees F
Temperature MQ 3 TSen    48 degrees C / 118 degrees F
Temperature MQ 3 Chip    47 degrees C / 116 degrees F
Power
AS-BIAS3V3-z12105       3299 mV
AS-VDD1V8-z12006        1805 mV
AS-VDD2V5-z12006        2510 mV
AS-AVDD1V0-z12004        999 mV
AS-PCIE_1V0-z12004        998 mV
AS-VDD3V3-z12004        3296 mV
AS-VDD_1V5A-z12004       1492 mV
AS-VDD_1V5B-z12004       1497 mV
AS-LU0_1V0-z12004        997 mV

```

AS-LU1_1V0-z12004	1000 mV
AS-MQ0_1V0-z12004	998 mV
AS-MQ1_1V0-z12004	1001 mV
AS-LU2_1V0-z12004	996 mV
AS-LU3_1V0-z12004	995 mV
AS-MQ2_1V0-z12004	998 mV
AS-MQ3_1V0-z12004	997 mV
AS-PMB_1V1-z12006	1100 mV

I2C Slave Revision 68

FPC 3 status:

State	Online
Temperature Intake	41 degrees C / 105 degrees F
Temperature Exhaust A	48 degrees C / 118 degrees F
Temperature Exhaust B	58 degrees C / 136 degrees F
Temperature LU 0 TSen	56 degrees C / 132 degrees F
Temperature LU 0 Chip	59 degrees C / 138 degrees F
Temperature LU 1 TSen	56 degrees C / 132 degrees F
Temperature LU 1 Chip	61 degrees C / 141 degrees F
Temperature LU 2 TSen	56 degrees C / 132 degrees F
Temperature LU 2 Chip	51 degrees C / 123 degrees F
Temperature LU 3 TSen	56 degrees C / 132 degrees F
Temperature LU 3 Chip	53 degrees C / 127 degrees F
Temperature MQ 0 TSen	50 degrees C / 122 degrees F
Temperature MQ 0 Chip	51 degrees C / 123 degrees F
Temperature MQ 1 TSen	50 degrees C / 122 degrees F
Temperature MQ 1 Chip	55 degrees C / 131 degrees F
Temperature MQ 2 TSen	50 degrees C / 122 degrees F
Temperature MQ 2 Chip	47 degrees C / 116 degrees F
Temperature MQ 3 TSen	50 degrees C / 122 degrees F
Temperature MQ 3 Chip	50 degrees C / 122 degrees F

Power

AS-BIAS3V3-z12105	3305 mV
AS-VDD1V8-z12006	1810 mV
AS-VDD2V5-z12006	2508 mV
AS-AVDD1V0-z12004	999 mV
AS-PCIE_1V0-z12004	1001 mV
AS-VDD3V3-z12004	3294 mV
AS-VDD_1V5A-z12004	1500 mV
AS-VDD_1V5B-z12004	1498 mV
AS-LU0_1V0-z12004	998 mV
AS-LU1_1V0-z12004	998 mV
AS-MQ0_1V0-z12004	999 mV
AS-MQ1_1V0-z12004	998 mV

```

AS-LU2_1V0-z12004      1000 mV
AS-LU3_1V0-z12004      1001 mV
AS-MQ2_1V0-z12004      996 mV
AS-MQ3_1V0-z12004      998 mV
AS-PMB_1V1-z12006      1098 mV
I2C Slave Revision      68
FPC 4 status:
...

```

show chassis environment fpc (MX2010 Router)

```

user@host> show chassis environment fpc
FPC 0 status:
State                Online
Temperature Intake    36 degrees C / 96 degrees F
Temperature Exhaust A 42 degrees C / 107 degrees F
Temperature Exhaust B 51 degrees C / 123 degrees F
Temperature LU 0 TSen 49 degrees C / 120 degrees F
Temperature LU 0 Chip 50 degrees C / 122 degrees F
Temperature LU 1 TSen 49 degrees C / 120 degrees F
Temperature LU 1 Chip 54 degrees C / 129 degrees F
Temperature LU 2 TSen 49 degrees C / 120 degrees F
Temperature LU 2 Chip 45 degrees C / 113 degrees F
Temperature LU 3 TSen 49 degrees C / 120 degrees F
Temperature LU 3 Chip 46 degrees C / 114 degrees F
Temperature MQ 0 TSen 40 degrees C / 104 degrees F
Temperature MQ 0 Chip 41 degrees C / 105 degrees F
Temperature MQ 1 TSen 40 degrees C / 104 degrees F
Temperature MQ 1 Chip 44 degrees C / 111 degrees F
Temperature MQ 2 TSen 40 degrees C / 104 degrees F
Temperature MQ 2 Chip 38 degrees C / 100 degrees F
Temperature MQ 3 TSen 40 degrees C / 104 degrees F
Temperature MQ 3 Chip 41 degrees C / 105 degrees F
Power
AS-BIAS3V3-z12105      3300 mV
AS-VDD1V8-z12006      1805 mV
AS-VDD2V5-z12006      2505 mV
AS-AVDD1V0-z12004      998 mV
AS-PCIE_1V0-z12004      999 mV
AS-VDD3V3-z12004      3303 mV
AS-VDD_1V5A-z12004      1497 mV

```

```

AS-VDD_1V5B-z12004      1497 mV
AS-LU0_1V0-z12004       998 mV
AS-LU1_1V0-z12004      1003 mV
AS-MQ0_1V0-z12004       998 mV
AS-MQ1_1V0-z12004       998 mV
AS-LU2_1V0-z12004       997 mV
AS-LU3_1V0-z12004      1001 mV
AS-MQ2_1V0-z12004       996 mV
AS-MQ3_1V0-z12004       994 mV
AS-PMB_1V1-z12006      1097 mV
I2C Slave Revision      68
FPC 1 status:
State                    Online
Temperature Intake       34 degrees C / 93 degrees F
Temperature Exhaust A    46 degrees C / 114 degrees F
Temperature Exhaust B    54 degrees C / 129 degrees F
Temperature LU 0 TSen    45 degrees C / 113 degrees F
Temperature LU 0 Chip    55 degrees C / 131 degrees F
Temperature LU 1 TSen    45 degrees C / 113 degrees F
Temperature LU 1 Chip    44 degrees C / 111 degrees F
Temperature LU 2 TSen    45 degrees C / 113 degrees F
Temperature LU 2 Chip    50 degrees C / 122 degrees F
Temperature LU 3 TSen    45 degrees C / 113 degrees F
Temperature LU 3 Chip    58 degrees C / 136 degrees F
Temperature XM 0 TSen    45 degrees C / 113 degrees F
Temperature XM 0 Chip    51 degrees C / 123 degrees F
Temperature XF 0 TSen    45 degrees C / 113 degrees F
Temperature XF 0 Chip    63 degrees C / 145 degrees F
Temperature PLX Switch TSen45 degrees C / 113 degrees F
Temperature PLX Switch Chip47 degrees C / 116 degrees F
Power
MPC-BIAS3V3-z12105      3300 mV
MPC-VDD3V3-z16100       3294 mV
MPC-VDD2V5-z16100       2505 mV
MPC-VDD1V8-z12004       1796 mV
MPC-AVDD1V0-z12004       991 mV
MPC-VDD1V2-z16100       1196 mV
MPC-VDD1V5A-z12004      1491 mV
MPC-VDD1V5B-z12004      1492 mV
MPC-XF_0V9-z12004       996 mV
MPC-PCIE_1V0-z16100     1003 mV
MPC-LU0_1V0-z12004       996 mV
MPC-LU1_1V0-z12004       996 mV

```



```

MPC-LU2_1V0-z12004      998 mV
MPC-LU3_1V0-z12004      994 mV
MPC-12VA-BMR453         12031 mV
MPC-12VB-BMR453         12003 mV
MPC-PMB_1V1-z12006      1104 mV
MPC-PMB_1V2-z12106      1194 mV
MPC-XM_0V9-vt273m       911 mV
I2C Slave Revision      110
FPC 8 status:
State                    Online
Temperature Intake       32 degrees C / 89 degrees F
Temperature Exhaust A    44 degrees C / 111 degrees F
Temperature Exhaust B    37 degrees C / 98 degrees F
Temperature LU 0 TCAM TSen 41 degrees C / 105 degrees F
Temperature LU 0 TCAM Chip 49 degrees C / 120 degrees F
Temperature LU 0 TSen    41 degrees C / 105 degrees F
Temperature LU 0 Chip    52 degrees C / 125 degrees F
Temperature MQ 0 TSen    41 degrees C / 105 degrees F
Temperature MQ 0 Chip    47 degrees C / 116 degrees F
Temperature LU 1 TCAM TSen 39 degrees C / 102 degrees F
Temperature LU 1 TCAM Chip 42 degrees C / 107 degrees F
Temperature LU 1 TSen    39 degrees C / 102 degrees F
Temperature LU 1 Chip    46 degrees C / 114 degrees F
Temperature MQ 1 TSen    39 degrees C / 102 degrees F
Temperature MQ 1 Chip    45 degrees C / 113 degrees F
Power
MPC-BIAS3V3-z12105      3296 mV
MPC-VDD3V3-z12006      3298 mV
MPC-VDD2V5-z12006      2505 mV
MPC-TCAM_1V0-z12004     997 mV
MPC-AVDD1V0-z12006     1007 mV
MPC-VDD1V8-z12006      1803 mV
MPC-PCIE_1V0-z12006    1004 mV
MPC-LU0_1V0-z12004     1000 mV
MPC-MQ0_1V0-z12004     999 mV
MPC-VDD_1V5-z12004     1498 mV
MPC-PMB_1V1-z12006     1102 mV
MPC-9VA-BMR453         9009 mV
MPC-9VB-BMR453         8960 mV
MPC-PMB_1V2-z12105     1202 mV
MPC-LU1_1V0-z12004     1005 mV
MPC-MQ1_1V0-z12004     1000 mV
I2C Slave Revision      70

```

FPC 9 status:

State	Online
Temperature Intake	34 degrees C / 93 degrees F
Temperature Exhaust A	41 degrees C / 105 degrees F
Temperature Exhaust B	54 degrees C / 129 degrees F
Temperature LU 0 TSen	51 degrees C / 123 degrees F
Temperature LU 0 Chip	52 degrees C / 125 degrees F
Temperature LU 1 TSen	51 degrees C / 123 degrees F
Temperature LU 1 Chip	55 degrees C / 131 degrees F
Temperature LU 2 TSen	51 degrees C / 123 degrees F
Temperature LU 2 Chip	47 degrees C / 116 degrees F
Temperature LU 3 TSen	51 degrees C / 123 degrees F
Temperature LU 3 Chip	47 degrees C / 116 degrees F
Temperature MQ 0 TSen	40 degrees C / 104 degrees F
Temperature MQ 0 Chip	42 degrees C / 107 degrees F
Temperature MQ 1 TSen	40 degrees C / 104 degrees F
Temperature MQ 1 Chip	44 degrees C / 111 degrees F
Temperature MQ 2 TSen	40 degrees C / 104 degrees F
Temperature MQ 2 Chip	38 degrees C / 100 degrees F
Temperature MQ 3 TSen	40 degrees C / 104 degrees F
Temperature MQ 3 Chip	40 degrees C / 104 degrees F
Power	
AS-BIAS3V3-z12105	3302 mV
AS-VDD1V8-z12006	1808 mV
AS-VDD2V5-z12006	2513 mV
AS-AVDD1V0-z12004	997 mV
AS-PCIE_1V0-z12004	999 mV
AS-VDD3V3-z12004	3294 mV
AS-VDD_1V5A-z12004	1503 mV
AS-VDD_1V5B-z12004	1502 mV
AS-LU0_1V0-z12004	996 mV
AS-LU1_1V0-z12004	999 mV
AS-MQ0_1V0-z12004	997 mV
AS-MQ1_1V0-z12004	999 mV
AS-LU2_1V0-z12004	997 mV
AS-LU3_1V0-z12004	998 mV
AS-MQ2_1V0-z12004	1000 mV
AS-MQ3_1V0-z12004	1000 mV
AS-PMB_1V1-z12006	1102 mV
I2C Slave Revision	68

show chassis environment fpc (MX2008 Router)

```

user@host> show chassis environment fpc
FPC 0 status:
  State                Online
  Temperature Intake    29 degrees C / 84 degrees F
  Temperature Exhaust A 43 degrees C / 109 degrees F
  Temperature Exhaust B 42 degrees C / 107 degrees F
  Temperature XL 0 TSen  38 degrees C / 100 degrees F
  Temperature XL 0 Chip  53 degrees C / 127 degrees F
  Temperature XL 0 XR2 0 TSen38 degrees C / 100 degrees F
  Temperature XL 0 XR2 0 Chip60 degrees C / 140 degrees F
  Temperature XL 0 XR2 1 TSen38 degrees C / 100 degrees F
  Temperature XL 0 XR2 1 Chip60 degrees C / 140 degrees F
  Temperature XL 1 TSen  30 degrees C / 86 degrees F
  Temperature XL 1 Chip  43 degrees C / 109 degrees F
  Temperature XL 1 XR2 0 TSen30 degrees C / 86 degrees F
  Temperature XL 1 XR2 0 Chip50 degrees C / 122 degrees F
  Temperature XL 1 XR2 1 TSen30 degrees C / 86 degrees F
  Temperature XL 1 XR2 1 Chip50 degrees C / 122 degrees F
  Temperature XM 0 TSen  42 degrees C / 107 degrees F
  Temperature XM 0 Chip  49 degrees C / 120 degrees F
  Temperature XM 1 TSen  42 degrees C / 107 degrees F
  Temperature XM 1 Chip  42 degrees C / 107 degrees F
  Temperature XM 2 TSen  42 degrees C / 107 degrees F
  Temperature XM 2 Chip  42 degrees C / 107 degrees F
  Temperature XM 3 TSen  42 degrees C / 107 degrees F
  Temperature XM 3 Chip  40 degrees C / 104 degrees F
  Temperature PCIe Switch TSen42 degrees C / 107 degrees F
  Temperature PCIe Switch Chip22 degrees C / 71 degrees F
Power
  MPC-VDD_3V3-vt273m    3304 mV
  MPC-VDD_2V5-vt273m    2503 mV
  MPC-VDD_1V5-vt273m    1499 mV
  MPC-PCIE_0V9-vt273m    900 mV
  MPC-VDD_1V8-vt273m    1799 mV
  MPC-VDD_1V2-vt273m    1203 mV
  MPC-XM01_AVDD_1V0-vt273 1001 mV
  MPC-XM23_AVDD_1V0-vt273 1001 mV
  MPC-XM0_0V9-vt273m    900 mV
  MPC-XM1_0V9-vt273m    901 mV
  MPC-XM2_0V9-vt273m    903 mV

```

MPC-XM3_0V9-vt273m	899 mV
MPC-XL0_XR0_0V9-vt273m	899 mV
MPC-XL0_XR1_0V9-vt273m	903 mV
MPC-XL0_0V9-vt273m	899 mV
MPC-XL0_AVDD_1V0-vt273m	1000 mV
MPC-XL0_VDD_1V5-vt273m	1498 mV
MPC-XL0_XR_1V2-vt273m	1200 mV
MPC-XL1_XR0_0V9-vt273m	899 mV
MPC-XL1_XR1_0V9-vt273m	899 mV
MPC-XL1_0V9-vt273m	900 mV
MPC-XL1_AVDD_1V0-vt273m	1000 mV
MPC-XL1_VDD_1V5-vt273m	1501 mV
MPC-XL1_XR_1V2-vt273m	1199 mV
MPC-PMB-1V05-ltc2978	1049 mV
MPC-PMB-1V5-ltc2978	1500 mV
MPC-PMB-2V5-ltc2978	2500 mV
MPC-PMB-3V3-ltc2978	3298 mV

I2C Slave Revision 20

FPC 1 status:

State	Online
Temperature Intake	29 degrees C / 84 degrees F
Temperature Exhaust A	52 degrees C / 125 degrees F
Temperature Exhaust B	44 degrees C / 111 degrees F
Temperature EA0 TSen	55 degrees C / 131 degrees F
Temperature EA0 Chip	48 degrees C / 118 degrees F
Temperature EA0_XR0 TSen	55 degrees C / 131 degrees F
Temperature EA0_XR0 Chip	57 degrees C / 134 degrees F
Temperature EA0_XR1 TSen	55 degrees C / 131 degrees F
Temperature EA0_XR1 Chip	54 degrees C / 129 degrees F
Temperature EA1 TSen	55 degrees C / 131 degrees F
Temperature EA1 Chip	50 degrees C / 122 degrees F
Temperature EA1_XR0 TSen	55 degrees C / 131 degrees F
Temperature EA1_XR0 Chip	59 degrees C / 138 degrees F
Temperature EA1_XR1 TSen	55 degrees C / 131 degrees F
Temperature EA1_XR1 Chip	59 degrees C / 138 degrees F
Temperature PEX TSen	55 degrees C / 131 degrees F
Temperature PEX Chip	39 degrees C / 102 degrees F
Temperature EA2 TSen	43 degrees C / 109 degrees F
Temperature EA2 Chip	39 degrees C / 102 degrees F
Temperature EA2_XR0 TSen	43 degrees C / 109 degrees F
Temperature EA2_XR0 Chip	45 degrees C / 113 degrees F
Temperature EA2_XR1 TSen	43 degrees C / 109 degrees F
Temperature EA2_XR1 Chip	43 degrees C / 109 degrees F

Temperature EA3 TSen 43 degrees C / 109 degrees F
 Temperature EA3 Chip 41 degrees C / 105 degrees F
 Temperature EA3_XR0 TSen 43 degrees C / 109 degrees F
 Temperature EA3_XR0 Chip 50 degrees C / 122 degrees F
 Temperature EA3_XR1 TSen 43 degrees C / 109 degrees F
 Temperature EA3_XR1 Chip 46 degrees C / 114 degrees F
 Temperature EA0_HMC0 Logic die 61 degrees C / 141 degrees F
 Temperature EA0_HMC0 DRAM botm 58 degrees C / 136 degrees F
 Temperature EA0_HMC1 Logic die 62 degrees C / 143 degrees F
 Temperature EA0_HMC1 DRAM botm 59 degrees C / 138 degrees F
 Temperature EA0_HMC2 Logic die 59 degrees C / 138 degrees F
 Temperature EA0_HMC2 DRAM botm 56 degrees C / 132 degrees F
 Temperature EA1_HMC0 Logic die 67 degrees C / 152 degrees F
 Temperature EA1_HMC0 DRAM botm 64 degrees C / 147 degrees F
 Temperature EA1_HMC1 Logic die 65 degrees C / 149 degrees F
 Temperature EA1_HMC1 DRAM botm 62 degrees C / 143 degrees F
 Temperature EA1_HMC2 Logic die 63 degrees C / 145 degrees F
 Temperature EA1_HMC2 DRAM botm 60 degrees C / 140 degrees F
 Temperature EA2_HMC0 Logic die 51 degrees C / 123 degrees F
 Temperature EA2_HMC0 DRAM botm 48 degrees C / 118 degrees F
 Temperature EA2_HMC1 Logic die 55 degrees C / 131 degrees F
 Temperature EA2_HMC1 DRAM botm 52 degrees C / 125 degrees F
 Temperature EA2_HMC2 Logic die 52 degrees C / 125 degrees F
 Temperature EA2_HMC2 DRAM botm 49 degrees C / 120 degrees F
 Temperature EA3_HMC0 Logic die 51 degrees C / 123 degrees F
 Temperature EA3_HMC0 DRAM botm 48 degrees C / 118 degrees F
 Temperature EA3_HMC1 Logic die 52 degrees C / 125 degrees F
 Temperature EA3_HMC1 DRAM botm 49 degrees C / 120 degrees F
 Temperature EA3_HMC2 Logic die 52 degrees C / 125 degrees F
 Temperature EA3_HMC2 DRAM botm 49 degrees C / 120 degrees F

Power

MPC-EA0_0V9-vt1527mb 950 mV
 MPC-EA1_0V9-vt1527mb 950 mV
 MPC-EA2_0V9-vt1527mb 925 mV
 MPC-EA3_0V9-vt1527mb 924 mV
 MAX20751-1V0 1020 mV
 MAX20731-0V9 891 mV
 MAX20751-EA0-AVDD1V0 1000 mV
 MAX20731-EA0-1V2 1189 mV
 MAX20731-EA0-HMC-1V2 1182 mV
 MAX20731-EA0-0V906 899 mV
 MAX20731-EA0-HMC-0V9 891 mV
 MAX20751-EA1-AVDD1V0 1000 mV

MAX20731-EA1-1V2	1189 mV
MAX20731-EA1-HMC-1V2	1182 mV
MAX20731-EA1-0V906	899 mV
MAX20731-EA1-HMC-0V9	889 mV
MAX20751-EA2-AVDD1V0	1000 mV
MAX20731-EA2-1V2	1186 mV
MAX20731-EA2-HMC-1V2	1193 mV
MAX20731-EA2-0V906	899 mV
MAX20731-EA2-HMC-0V9	889 mV
MAX20751-EA3-AVDD1V0	1000 mV
MAX20731-EA3-1V2	1186 mV
MAX20731-EA3-HMC-1V2	1193 mV
MAX20731-EA3-0V906	897 mV
MAX20731-EA3-HMC-0V9	894 mV
MAX20731-3V3	3268 mV
UCD9090_0-CH_1-EA0_PLL_	1010 mV
UCD9090_0-CH_2-EA0_1V04	1038 mV
UCD9090_0-CH_3-EA0_2V5	2499 mV
UCD9090_0-CH_4-EA0_1V5	1494 mV
UCD9090_0-CH_5-EA1_PLL_	1012 mV
UCD9090_0-CH_6-EA1_1V04	1038 mV
UCD9090_0-CH_7-EA1_2V5	2497 mV
UCD9090_0-CH_8-EA1_1V5	1498 mV
UCD9090_0-CH_9-VDD_1V8	1804 mV
UCD9090_0-CH_10-VDD_2V5	2499 mV
UCD9090_1-CH_1-EA2_PLL_	1017 mV
UCD9090_1-CH_2-EA2_1V04	1041 mV
UCD9090_1-CH_3-EA2_2V5	2499 mV
UCD9090_1-CH_4-EA2_1V5	1503 mV
UCD9090_1-CH_5-EA3_PLL_	1015 mV
UCD9090_1-CH_6-EA3_1V04	1048 mV
UCD9090_1-CH_7-EA3_2V5	2499 mV
UCD9090_1-CH_8-EA3_1V5	1500 mV
UCD9090_1-CH_9-VDD_1V5	1497 mV
UCD9090_1-CH_10-VDD_1V2	1216 mV
PMB PVCC 0.7V - 1.05V	802 mV
PMB PVNN 0V - 1.02V	976 mV
PMB 1.0V	1002 mV
PMB 1.1V	1076 mV
PMB 1.35V	1347 mV
PMB VDDQ 1.5V	1504 mV
PMB 1.8V	1804 mV
PMB VDD 3.3V	3292 mV

```

PMB BIAS 5.0V          5008 mV
PMB USB 5.0V          5000 mV
PMB 12V                10866 mV
I2C Slave Revision    112
FPC 7 status:
State                  Online
Temperature Intake     31 degrees C / 87 degrees F
Temperature Exhaust A  46 degrees C / 114 degrees F
Temperature Exhaust B  38 degrees C / 100 degrees F
Temperature QX 0 TSen  49 degrees C / 120 degrees F
Temperature QX 0 Chip  52 degrees C / 125 degrees F
Temperature LU 0 TCAM TSen 49 degrees C / 120 degrees F
Temperature LU 0 TCAM Chip 52 degrees C / 125 degrees F
Temperature LU 0 TSen   49 degrees C / 120 degrees F
Temperature LU 0 Chip   51 degrees C / 123 degrees F
Temperature MQ 0 TSen   49 degrees C / 120 degrees F
Temperature MQ 0 Chip   55 degrees C / 131 degrees F
Temperature QX 1 TSen   41 degrees C / 105 degrees F
Temperature QX 1 Chip   42 degrees C / 107 degrees F
Temperature LU 1 TCAM TSen 41 degrees C / 105 degrees F
Temperature LU 1 TCAM Chip 43 degrees C / 109 degrees F
Temperature LU 1 TSen   41 degrees C / 105 degrees F
Temperature LU 1 Chip   46 degrees C / 114 degrees F
Temperature MQ 1 TSen   41 degrees C / 105 degrees F
Temperature MQ 1 Chip   47 degrees C / 116 degrees F
Power
MPC-BIAS3V3-z12105    3302 mV
MPC-VDD3V3-z12006     3307 mV
MPC-VDD2V5-z12006     2505 mV
MPC-TCAM_1V0-z12004   1000 mV
MPC-AVDD1V0-z12006    1006 mV
MPC-VDD1V8-z12006     1800 mV
MPC-PCIE_1V0-z12006   1000 mV
MPC-LU0_1V0-z12004    997 mV
MPC-MQ0_1V0-z12004    999 mV
MPC-VDD_1V5-z12004    1495 mV
MPC-PMB_1V1-z12006    1096 mV
MPC-9VA-BMR453        9051 mV
MPC-9VB-BMR453        8990 mV
MPC-PMB_1V2-z12106    1200 mV
MPC-LU1_1V0-z12004    997 mV
MPC-MQ1_1V0-z12004    998 mV
MPC-QXM0_1V0-z12006   1000 mV

```

```

MPC-QXM1_1V0-z12006          999 mV
I2C Slave Revision            70

```

show chassis environment fpc (MX240 Router)

```

user@host> show chassis environment fpc
FPC 1 status:
  State                Online
  Temperature Intake    34 degrees C / 93 degrees F
  Temperature Exhaust A 39 degrees C / 102 degrees F
  Temperature Exhaust B 53 degrees C / 127 degrees F
  Temperature I3 0 TSensor 51 degrees C / 123 degrees F
  Temperature I3 0 Chip  54 degrees C / 129 degrees F
  Temperature I3 1 TSensor 50 degrees C / 122 degrees F
  Temperature I3 1 Chip  53 degrees C / 127 degrees F
  Temperature I3 2 TSensor 48 degrees C / 118 degrees F
  Temperature I3 2 Chip  51 degrees C / 123 degrees F
  Temperature I3 3 TSensor 45 degrees C / 113 degrees F
  Temperature I3 3 Chip  48 degrees C / 118 degrees F
  Temperature IA 0 TSensor 45 degrees C / 113 degrees F
  Temperature IA 0 Chip  45 degrees C / 113 degrees F
  Temperature IA 1 TSensor 45 degrees C / 113 degrees F
  Temperature IA 1 Chip  49 degrees C / 120 degrees F
Power
  1.5 V                1492 mV
  2.5 V                2507 mV
  3.3 V                3306 mV
  1.8 V PFE 0         1801 mV
  1.8 V PFE 1         1804 mV
  1.8 V PFE 2         1798 mV
  1.8 V PFE 3         1798 mV
  1.2 V PFE 0         1169 mV
  1.2 V PFE 1         1189 mV
  1.2 V PFE 2         1182 mV
  1.2 V PFE 3         1176 mV
  I2C Slave Revision  42
FPC 2 status:
  State                Online
  Temperature Intake    33 degrees C / 91 degrees F
  Temperature Exhaust A 41 degrees C / 105 degrees F
  Temperature Exhaust B 53 degrees C / 127 degrees F

```



```

Temperature I3 0 TSensor 53 degrees C / 127 degrees F
Temperature I3 0 Chip    58 degrees C / 136 degrees F
Temperature I3 1 TSensor 52 degrees C / 125 degrees F
Temperature I3 1 Chip    56 degrees C / 132 degrees F
Temperature I3 2 TSensor 50 degrees C / 122 degrees F
Temperature I3 2 Chip    52 degrees C / 125 degrees F
Temperature I3 3 TSensor 46 degrees C / 114 degrees F
Temperature I3 3 Chip    49 degrees C / 120 degrees F
Temperature IA 0 TSensor 51 degrees C / 123 degrees F
Temperature IA 0 Chip    49 degrees C / 120 degrees F
Temperature IA 1 TSensor 48 degrees C / 118 degrees F
Temperature IA 1 Chip    53 degrees C / 127 degrees F
Power
  1.5 V                1492 mV
  2.5 V                2445 mV
  3.3 V                3293 mV
  1.8 V PFE 0         1827 mV
  1.8 V PFE 1         1775 mV
  1.8 V PFE 2         1788 mV
  1.8 V PFE 3         1798 mV
  1.2 V PFE 0         1250 mV
  1.2 V PFE 1         1234 mV
  1.2 V PFE 2         1231 mV
  1.2 V PFE 3         1192 mV
I2C Slave Revision    42

```

show chassis environment fpc (MX480 Router)

```

user@host> show chassis environment fpc
FPC 1 status:
State                Online
Temperature Intake   36 degrees C / 96 degrees F
Temperature Exhaust A 41 degrees C / 105 degrees F
Temperature Exhaust B 55 degrees C / 131 degrees F
Temperature I3 0 TSensor 55 degrees C / 131 degrees F
Temperature I3 0 Chip 57 degrees C / 134 degrees F
Temperature I3 1 TSensor 53 degrees C / 127 degrees F
Temperature I3 1 Chip 53 degrees C / 127 degrees F
Temperature I3 2 TSensor 52 degrees C / 125 degrees F
Temperature I3 2 Chip 49 degrees C / 120 degrees F
Temperature I3 3 TSensor 47 degrees C / 116 degrees F

```

```

Temperature I3 3 Chip      47 degrees C / 116 degrees F
Temperature IA 0 TSensor   54 degrees C / 129 degrees F
Temperature IA 0 Chip      58 degrees C / 136 degrees F
Temperature IA 1 TSensor   48 degrees C / 118 degrees F
Temperature IA 1 Chip      53 degrees C / 127 degrees F
Power
  1.5 V                    1479 mV
  2.5 V                    2542 mV
  3.3 V                    3319 mV
  1.8 V PFE 0              1811 mV
  1.8 V PFE 1              1804 mV
  1.8 V PFE 2              1804 mV
  1.8 V PFE 3              1814 mV
  1.2 V PFE 0              1192 mV
  1.2 V PFE 1              1202 mV
  1.2 V PFE 2              1205 mV
  1.2 V PFE 3              1189 mV
I2C Slave Revision        40

```

show chassis environment fpc (MX960 Router MPC10E-15C-MRATE)

```
user@router> show chassis environment fpc 8
```

```
FPC 8 status:
```

```

State                Online
Temperature Intake    37 degrees C / 98 degrees F
Temperature Exhaust A 50 degrees C / 122 degrees F
Temperature Exhaust B 56 degrees C / 132 degrees F
Temperature ZT0 Chip  83 degrees C / 181 degrees F
Temperature ZT1 Chip  80 degrees C / 176 degrees F
Temperature ZT2 Chip  81 degrees C / 177 degrees F
Temperature PCIE_SW Chip 64 degrees C / 147 degrees F
Temperature ZT0 TestMacro 73 degrees C / 163 degrees F
Temperature ZT0 hbmio_grp3 74 degrees C / 165 degrees F
Temperature ZT0 hbmio_grp0 76 degrees C / 168 degrees F
Temperature ZT0 gumem1 78 degrees C / 172 degrees F
Temperature ZT0 l1m    80 degrees C / 176 degrees F
Temperature ZT0 wanio_sd 78 degrees C / 172 degrees F
Temperature ZT0 fabio_sd 84 degrees C / 183 degrees F
Temperature ZT0 flexmem 84 degrees C / 183 degrees F
Temperature ZT1 TestMacro 70 degrees C / 158 degrees F

```

Temperature ZT1 hbmio_grp3	71 degrees C / 159 degrees F
Temperature ZT1 hbmio_grp0	74 degrees C / 165 degrees F
Temperature ZT1 gumem1	75 degrees C / 167 degrees F
Temperature ZT1 llm	78 degrees C / 172 degrees F
Temperature ZT1 wanio_sd	76 degrees C / 168 degrees F
Temperature ZT1 fabio_sd	78 degrees C / 172 degrees F
Temperature ZT1 flexmem	82 degrees C / 179 degrees F
Temperature ZT2 TestMacro	71 degrees C / 159 degrees F
Temperature ZT2 hbmio_grp3	72 degrees C / 161 degrees F
Temperature ZT2 hbmio_grp0	75 degrees C / 167 degrees F
Temperature ZT2 gumem1	76 degrees C / 168 degrees F
Temperature ZT2 llm	78 degrees C / 172 degrees F
Temperature ZT2 wanio_sd	78 degrees C / 172 degrees F
Temperature ZT2 fabio_sd	80 degrees C / 176 degrees F
Temperature ZT2 flexmem	76 degrees C / 168 degrees F
Temperature ZT0 HBM0	74 degrees C / 165 degrees F
Temperature ZT0 HBM1	74 degrees C / 165 degrees F
Temperature ZT1 HBM0	74 degrees C / 165 degrees F
Temperature ZT1 HBM1	75 degrees C / 167 degrees F
Temperature ZT2 HBM0	73 degrees C / 163 degrees F
Temperature ZT2 HBM1	73 degrees C / 163 degrees F
Temperature FAB RT1.0	73 degrees C / 163 degrees F
Temperature FAB RT2.0	75 degrees C / 167 degrees F
Temperature FAB RT3.0	73 degrees C / 163 degrees F
Temperature FAB RT4.0	70 degrees C / 158 degrees F
Temperature FAB RT5.0	67 degrees C / 152 degrees F
Temperature FAB RT6.0	67 degrees C / 152 degrees F
Temperature FAB RT7.0	65 degrees C / 149 degrees F
Temperature FAB RT8.0	66 degrees C / 150 degrees F
Temperature WAN RT9.0	64 degrees C / 147 degrees F
Temperature WAN RT9.1	62 degrees C / 143 degrees F
Temperature WAN RT10.0	65 degrees C / 149 degrees F
Temperature WAN RT10.1	63 degrees C / 145 degrees F
Temperature WAN RT11.0	51 degrees C / 123 degrees F
Temperature WAN RT11.1	49 degrees C / 120 degrees F
Temperature PIM4820 T1	72 degrees C / 161 degrees F
Temperature BMR456-12V-BRICK-A T1	83 degrees C / 181 degrees F
Temperature BMR456-12V-BRICK-B T1	91 degrees C / 195 degrees F
Temperature MAX20730-ZT0-AVDDH T1	72 degrees C / 161 degrees F
Temperature MAX20730-ZT0-HBM-VDDQ T1	64 degrees C / 147 degrees F
Temperature MAX20730-ZT0-HBM-VDDC T1	65 degrees C / 149 degrees F
Temperature MAX20730-ZT1-AVDDH T1	65 degrees C / 149 degrees F
Temperature MAX20730-ZT1-HBM-VDDQ T1	60 degrees C / 140 degrees F

Temperature MAX20730-ZT1-HBM-VDDC T1	57 degrees C / 134 degrees F
Temperature MAX20730-ZT2-AVDDH T1	65 degrees C / 149 degrees F
Temperature MAX20730-ZT2-HBM-VDDQ T1	58 degrees C / 136 degrees F
Temperature MAX20730-ZT2-HBM-VDDC T1	55 degrees C / 131 degrees F
Temperature CPU0_PMB	61 degrees C / 141 degrees F
Temperature CPU7_PMB	61 degrees C / 141 degrees F
Temperature DDR4 A	38 degrees C / 100 degrees F
Temperature DDR4 B	37 degrees C / 98 degrees F

Power

PIM4820	56967 mV
BMR456-12V-BRICK-A	12016 mV
BMR456-12V-BRICK-B	12039 mV
MAX20743-RT01-DVDD	724 mV
MAX20743-RT234-DVDD	724 mV
MAX20743-RT567-DVDD	724 mV
MAX20754-ZT0-VDD	750 mV
MAX20754-ZT0-VDDM	799 mV
MAX20743-ZT0-AVDD	904 mV
MAX20730-ZT0-AVDDH	1103 mV
MAX20730-ZT0-HBM-VDDQ	1198 mV
MAX20730-ZT0-HBM-VDDC	1202 mV
MAX20730-VDD-1V25	1246 mV
MAX20754-ZT1-VDD	724 mV
MAX20754-ZT1-VDDM	800 mV
MAX20743-ZT1-AVDD	904 mV
MAX20730-ZT1-AVDDH	1103 mV
MAX20730-ZT1-HBM-VDDQ	1202 mV
MAX20730-ZT1-HBM-VDDC	1198 mV
MAX20730-PCIE-0V9	901 mV
MAX20754-ZT2-VDD	724 mV
MAX20754-ZT2-VDDM	799 mV
MAX20743-ZT2-AVDD	904 mV
MAX20730-ZT2-AVDDH	1103 mV
MAX20730-ZT2-HBM-VDDQ	1198 mV
MAX20730-ZT2-HBM-VDDC	1198 mV
MAX20730-VDD3V3	3308 mV
MAX20754-WAN-VDD3V3	3301 mV
MAX20754-WAN-DVDD0V8	799 mV
MAX20743-WAN-VDD1V0A	1003 mV
MAX20743-WAN-AVDD0V8	800 mV
MAX20743-WAN-VDD1V0C	1003 mV
TPS53631-1V2-VDDQ-PMB	1225 mV
TPS53641-VCCIN-PMB	1770 mV

TPS53641-VCCSBUS-PMB	1040 mV
MAX20730-BIAS3P30-PMB	3308 mV
MAX20730-BIAS5P0-PMB	5063 mV
MAX20730-VPP-V2P5-PMB	2503 mV
MAX20730-VDD1V2	1195 mV
MAX20730-VDD1V5	1496 mV
MAX20730-VDD1V8	1799 mV
MAX20730-VDD2V5	2511 mV
MAX20754-RT-AVDD-0V8	800 mV
MAX20743-XGE-VDD-AVS	1012 mV
PMB VCC1P05_PCH_SW	1048 mV
PMB VCC1P3	1294 mV
PMB VCC1P5	1485 mV
PMB VCC1P7	1705 mV
PMB DDR4_VPP	2519 mV
PMB VCC3P3	3336 mV
PMB VCC3P3_PCH	3332 mV
I2C Slave Revision	124

show chassis environment fpc (MX960 Router)

```

user@host> show chassis environment fpc
FPC 5 status:
  State                Online
  Temperature Intake    27 degrees C / 80 degrees F
  Temperature Exhaust A 34 degrees C / 93 degrees F
  Temperature Exhaust B 40 degrees C / 104 degrees F
  Temperature I3 0 TSensor 39 degrees C / 102 degrees F
  Temperature I3 0 Chip  41 degrees C / 105 degrees F
  Temperature I3 1 TSensor 38 degrees C / 100 degrees F
  Temperature I3 1 Chip  37 degrees C / 98 degrees F
  Temperature I3 2 TSensor 37 degrees C / 98 degrees F
  Temperature I3 2 Chip  34 degrees C / 93 degrees F
  Temperature I3 3 TSensor 32 degrees C / 89 degrees F
  Temperature I3 3 Chip  33 degrees C / 91 degrees F
  Temperature IA 0 TSensor 39 degrees C / 102 degrees F
  Temperature IA 0 Chip  44 degrees C / 111 degrees F
  Temperature IA 1 TSensor 36 degrees C / 96 degrees F
  Temperature IA 1 Chip  44 degrees C / 111 degrees F
  Power
    1.5 V                1479 mV

```

2.5 V	2523 mV
3.3 V	3254 mV
1.8 V PFE 0	1798 mV
1.8 V PFE 1	1798 mV
1.8 V PFE 2	1807 mV
1.8 V PFE 3	1791 mV
1.2 V PFE 0	1173 mV
1.2 V PFE 1	1179 mV
1.2 V PFE 2	1179 mV
1.2 V PFE 3	1185 mV
I2C Slave Revision	6
FPC 6 status:	
State	Online
Temperature Intake	25 degrees C / 77 degrees F
Temperature Exhaust A	38 degrees C / 100 degrees F
Temperature Exhaust B	38 degrees C / 100 degrees F
Temperature I3 0 TSensor	40 degrees C / 104 degrees F
Temperature I3 0 Chip	40 degrees C / 104 degrees F
Temperature I3 1 TSensor	40 degrees C / 104 degrees F
Temperature I3 1 Chip	38 degrees C / 100 degrees F
Temperature I3 2 TSensor	37 degrees C / 98 degrees F
Temperature I3 2 Chip	32 degrees C / 89 degrees F
Temperature I3 3 TSensor	34 degrees C / 93 degrees F
Temperature I3 3 Chip	33 degrees C / 91 degrees F
Temperature IA 0 TSensor	45 degrees C / 113 degrees F
Temperature IA 0 Chip	47 degrees C / 116 degrees F
Temperature IA 1 TSensor	37 degrees C / 98 degrees F
Temperature IA 1 Chip	42 degrees C / 107 degrees F
Power	
1.5 V	1485 mV
2.5 V	2510 mV
3.3 V	3332 mV
1.8 V PFE 0	1801 mV
1.8 V PFE 1	1814 mV
1.8 V PFE 2	1804 mV
1.8 V PFE 3	1820 mV
1.2 V PFE 0	1192 mV
1.2 V PFE 1	1189 mV
1.2 V PFE 2	1202 mV
1.2 V PFE 3	1156 mV
I2C Slave Revision	40

show chassis environment fpc (MX480 Router with 100-Gigabit Ethernet CFP)

```

user@host> show chassis environment fpc
FPC 0 status:
  State                Online
  Temperature Intake    32 degrees C / 89 degrees F
  Temperature Exhaust A 39 degrees C / 102 degrees F
  Temperature Exhaust B 37 degrees C / 98 degrees F
  Temperature QX 0 TSen  44 degrees C / 111 degrees F
  Temperature QX 0 Chip  48 degrees C / 118 degrees F
  Temperature LU 0 TCAM TSen 44 degrees C / 111 degrees F
  Temperature LU 0 TCAM Chip 47 degrees C / 116 degrees F
  Temperature LU 0 TSen  44 degrees C / 111 degrees F
  Temperature LU 0 Chip  48 degrees C / 118 degrees F
  Temperature MQ 0 TSen  44 degrees C / 111 degrees F
  Temperature MQ 0 Chip  47 degrees C / 116 degrees F
Power
  MPC-BIAS3V3-z12105    3297 mV
  MPC-VDD3V3-z12105    3306 mV
  MPC-VDD2V5-z12105    2498 mV
  MPC-TCAM_1V0-z12004   999 mV
  MPC-AVDD1V0-z12006    999 mV
  MPC-VDD1V8-z12006    1796 mV
  MPC-PCIE_1V0-z12006  1002 mV
  MPC-LU0_1V0-z12004   997 mV
  MPC-MQ0_1V0-z12004   995 mV
  MPC-VDD_1V5-z12004   1496 mV
  MPC-PMB_1V1-z12006   1094 mV
  MPC-9VA-BMR453       9054 mV
  MPC-9VB-BMR453       9037 mV
  MPC-PMB_1V2-z12106   1191 mV
  MPC-QXM0_1V0-z12006  1000 mV
I2C Slave Revision    66
FPC 1 status:
  State                Online
  Temperature Intake    35 degrees C / 95 degrees F
  Temperature Exhaust A 50 degrees C / 122 degrees F
  Temperature Exhaust B 56 degrees C / 132 degrees F
  Temperature LU 0 TSen  46 degrees C / 114 degrees F
  Temperature LU 0 Chip  59 degrees C / 138 degrees F
  Temperature LU 1 TSen  46 degrees C / 114 degrees F
  Temperature LU 1 Chip  45 degrees C / 113 degrees F

```

```

Temperature LU 2 TSen      46 degrees C / 114 degrees F
Temperature LU 2 Chip      60 degrees C / 140 degrees F
Temperature LU 3 TSen      46 degrees C / 114 degrees F
Temperature LU 3 Chip      71 degrees C / 159 degrees F
Temperature XM 0 TSen      46 degrees C / 114 degrees F
Temperature XM 0 Chip      -18 degrees C / 0 degrees F
Temperature XF 0 TSen      46 degrees C / 114 degrees F
Temperature XF 0 Chip      76 degrees C / 168 degrees F
Power
MPC-BIAS3V3-z12105        3292 mV
MPC-VDD3V3-z16100         3303 mV
MPC-VDD2V5-z16100         2501 mV
MPC-VDD1V8-z12004         1801 mV
MPC-AVDD1V0-z12006         996 mV
MPC-VDD1V2-z16100         1199 mV
MPC-VDD1V5A-z12004         1493 mV
MPC-VDD1V5B-z12004         1498 mV
MPC-XF_0V9-z12006          996 mV
MPC-PCIE_1V0-z16100        1000 mV
MPC-LU0_1V0-z12004          994 mV
MPC-LU1_1V0-z12004          994 mV
MPC-LU2_1V0-z12004          992 mV
MPC-LU3_1V0-z12004          993 mV
MPC-12VA-BMR453            12003 mV
MPC-12VB-BMR453            12043 mV
MPC-PMB_1V1-z12006          1091 mV
MPC-PMB_1V2-z12106          1196 mV
MPC-XM_0V9-vt273m          899 mV
I2C Slave Revision         106

```

show chassis environment fpc (MX240, MX480, MX960 with Application Services Modular Line Card)

```

user@host>show chassis environment fpc 1
FPC 1 status:
State                Online
Temperature Intake    36 degrees C / 96 degrees F
Temperature Exhaust A 39 degrees C / 102 degrees F
Temperature LU TSen    52 degrees C / 125 degrees F
Temperature LU Chip    54 degrees C / 129 degrees F
Temperature XM TSen    52 degrees C / 125 degrees F

```



```

Temperature XM Chip      60 degrees C / 140 degrees F
Temperature PCIe TSen    52 degrees C / 125 degrees F
Temperature PCIe Chip    69 degrees C / 156 degrees F
Power
  MPC-BIAS3V3-z12106    3302 mV
  MPC-VDD3V3-z16100     3325 mV
  MPC-AVDD1V0-z16100    1007 mV
  MPC-PCIE_1V0-z16100   904 mV
  MPC-LU0_1V0-z12004    996 mV
  MPC-VDD_1V5-z12004    1498 mV
  MPC-12VA-BMR453       11733 mV
  MPC-12VB-BMR453       11728 mV
  MPC-XM_0V9-vt273m     900 mV
I2C Slave Revision      81

```

show chassis environment fpc (MX10003 Router)

```

user@host> show chassis environment fpc

FPC 0 status:
  State                Online
FPC 0 Intake Temp Sensor 29 degrees C / 84 degrees F
FPC 0 Exhaust-A Temp Sensor56 degrees C / 132 degrees F
FPC 0 Exhaust-B Temp Sensor44 degrees C / 111 degrees F
FPC 0 EA0 Chip          58 degrees C / 136 degrees F
FPC 0 EA0-XR0 Chip      61 degrees C / 141 degrees F
FPC 0 EA0-XR1 Chip      62 degrees C / 143 degrees F
FPC 0 EA1 Chip          67 degrees C / 152 degrees F
FPC 0 EA1-XR0 Chip      72 degrees C / 161 degrees F
FPC 0 EA1-XR1 Chip      72 degrees C / 161 degrees F
FPC 0 PEX Chip          77 degrees C / 170 degrees F
FPC 0 EA2 Chip          48 degrees C / 118 degrees F
FPC 0 EA2-XR0 Chip      54 degrees C / 129 degrees F
FPC 0 EA2-XR1 Chip      56 degrees C / 132 degrees F
FPC 0 PF Chip           68 degrees C / 154 degrees F
FPC 0 EA0_HMC0 Logic die 72 degrees C / 161 degrees F
FPC 0 EA0_HMC0 DRAM botm 69 degrees C / 156 degrees F
FPC 0 EA0_HMC1 Logic die 71 degrees C / 159 degrees F
FPC 0 EA0_HMC1 DRAM botm 68 degrees C / 154 degrees F
FPC 0 EA0_HMC2 Logic die 75 degrees C / 167 degrees F
FPC 0 EA0_HMC2 DRAM botm 72 degrees C / 161 degrees F

```

FPC 0 EA1_HMC0 Logic die	81 degrees C / 177 degrees F
FPC 0 EA1_HMC0 DRAM botm	78 degrees C / 172 degrees F
FPC 0 EA1_HMC1 Logic die	80 degrees C / 176 degrees F
FPC 0 EA1_HMC1 DRAM botm	77 degrees C / 170 degrees F
FPC 0 EA1_HMC2 Logic die	82 degrees C / 179 degrees F
FPC 0 EA1_HMC2 DRAM botm	79 degrees C / 174 degrees F
FPC 0 EA2_HMC0 Logic die	60 degrees C / 140 degrees F
FPC 0 EA2_HMC0 DRAM botm	57 degrees C / 134 degrees F
FPC 0 EA2_HMC1 Logic die	61 degrees C / 141 degrees F
FPC 0 EA2_HMC1 DRAM botm	58 degrees C / 136 degrees F
FPC 0 EA2_HMC2 Logic die	63 degrees C / 145 degrees F
FPC 0 EA2_HMC2 DRAM botm	60 degrees C / 140 degrees F

Power

LTC3887-PF-VDD0V9-RAIL	898 mV
LTC3887-PF-VDD0V9-DEV0-	898 mV
LTC3887-PF-VDD0V9-DEV0-	900 mV
LTC3887-PF-VDD0V9-DEV1-	899 mV
LTC3887-PF-VDD0V9-DEV1-	901 mV
LTC3887-PF-AVDD1V0-RAIL	998 mV
LTC3887-PF-AVDD1V0-CH0	998 mV
LTC3887-PF-AVDD1V0-CH1	999 mV
LTC3887-ETHSW-VDD1V0	1000 mV
LTC3887-VDD2V5	2499 mV
LTC3887-PCIE-VDD0V9	899 mV
LTC3887-V1P0	999 mV
LTC3887-PHY-VDD1V0-A	999 mV
LTC3887-3V3	3300 mV
LTC3887-VDD1V8	1799 mV
UCD9090_0-CH_1-EA0_PLL_	1005 mV
UCD9090_0-CH_2-EA0_1V4	1049 mV
UCD9090_0-CH_3-EA0_2V5	2499 mV
UCD9090_0-CH_4-EA0_1V5	1499 mV
UCD9090_0-CH_5-EA1_PLL_	999 mV
UCD9090_0-CH_6-EA1_1V4	1037 mV
UCD9090_0-CH_7-EA1_2V5	2499 mV
UCD9090_0-CH_8-EA1_1V5	1510 mV
UCD9090_0-CH_9-PVCC	797 mV
UCD9090_0-CH_10-PVNN	991 mV
UCD9090_1-CH_1-EA2_PLL_	1008 mV
UCD9090_1-CH_2-EA2_1V4	1009 mV
UCD9090_1-CH_3-EA2_2V5	2499 mV
UCD9090_1-CH_4-EA2_1V5	1513 mV
UCD9090_1-CH_5-1V0_PFL	1009 mV

UCD9090_1-CH_6-V1P1	1075 mV
UCD9090_1-CH_7-V1P5	1531 mV
UCD9090_1-CH_8-V1P35	1359 mV
UCD9090_1-CH_9-VDD1V5	1511 mV
UCD9090_1-CH_10-VDD1V2	1210 mV
LTC3887-EA0-VDD0V9-RAIL	949 mV
LTC3887-EA0-VDD0V9-DEV0	949 mV
LTC3887-EA0-VDD0V9-DEV0	951 mV
LTC3887-EA0-VDD0V9-DEV1	949 mV
LTC3887-EA0-VDD0V9-DEV1	951 mV
LTC3887-EA0-VDD0V9R2-RA	947 mV
LTC3887-EA0-VDD0V9R2-CH	947 mV
LTC3887-EA0-VDD0V9R2-CH	949 mV
LTC3887-EA0-VDD1V0-RAIL	999 mV
LTC3887-EA0-VDD1V0-CH0	999 mV
LTC3887-EA0-VDD1V0-CH1	1001 mV
LTC3887-EA0-XR-VDD0V9	900 mV
LTC3887-EA0-XR-VDD1V2	1199 mV
LTC3887-EA0-HM1-VDD0V9	899 mV
LTC3887-EA0-HM-VDD1V2	1200 mV
LTC3887-EA0-HM-VDDM1V2	1199 mV
LTC3887-EA1-VDD0V9-RAIL	949 mV
LTC3887-EA1-VDD0V9-DEV0	952 mV
LTC3887-EA1-VDD0V9-DEV0	952 mV
LTC3887-EA1-VDD0V9-DEV1	951 mV
LTC3887-EA1-VDD0V9-DEV1	951 mV
LTC3887-EA1-VDD0V9R2-RA	948 mV
LTC3887-EA1-VDD0V9R2-CH	948 mV
LTC3887-EA1-VDD0V9R2-CH	950 mV
LTC3887-EA1-VDD1V0-RAIL	1000 mV
LTC3887-EA1-VDD1V0-CH0	1000 mV
LTC3887-EA1-VDD1V0-CH1	1001 mV

I2C Slave Revision 13

FPC 1 status:

State	Online
FPC 1 Intake Temp Sensor	27 degrees C / 80 degrees F
FPC 1 Exhaust-A Temp Sensor	60 degrees C / 140 degrees F
FPC 1 Exhaust-B Temp Sensor	46 degrees C / 114 degrees F
FPC 1 EA0 Chip	63 degrees C / 145 degrees F
FPC 1 EA0-XR0 Chip	67 degrees C / 152 degrees F
FPC 1 EA0-XR1 Chip	68 degrees C / 154 degrees F
FPC 1 EA1 Chip	70 degrees C / 158 degrees F
FPC 1 EA1-XR0 Chip	75 degrees C / 167 degrees F

FPC 1 EA1-XR1 Chip	75 degrees C / 167 degrees F
FPC 1 PEX Chip	89 degrees C / 192 degrees F
FPC 1 EA2 Chip	49 degrees C / 120 degrees F
FPC 1 EA2-XR0 Chip	53 degrees C / 127 degrees F
FPC 1 EA2-XR1 Chip	56 degrees C / 132 degrees F
FPC 1 PF Chip	71 degrees C / 159 degrees F
FPC 1 EA0_HMC0 Logic die	74 degrees C / 165 degrees F
FPC 1 EA0_HMC0 DRAM botm	71 degrees C / 159 degrees F
FPC 1 EA0_HMC1 Logic die	78 degrees C / 172 degrees F
FPC 1 EA0_HMC1 DRAM botm	75 degrees C / 167 degrees F
FPC 1 EA0_HMC2 Logic die	78 degrees C / 172 degrees F
FPC 1 EA0_HMC2 DRAM botm	75 degrees C / 167 degrees F
FPC 1 EA1_HMC0 Logic die	84 degrees C / 183 degrees F
FPC 1 EA1_HMC0 DRAM botm	81 degrees C / 177 degrees F
FPC 1 EA1_HMC1 Logic die	82 degrees C / 179 degrees F
FPC 1 EA1_HMC1 DRAM botm	79 degrees C / 174 degrees F
FPC 1 EA1_HMC2 Logic die	85 degrees C / 185 degrees F
FPC 1 EA1_HMC2 DRAM botm	82 degrees C / 179 degrees F
FPC 1 EA2_HMC0 Logic die	62 degrees C / 143 degrees F
FPC 1 EA2_HMC0 DRAM botm	59 degrees C / 138 degrees F
FPC 1 EA2_HMC1 Logic die	60 degrees C / 140 degrees F
FPC 1 EA2_HMC1 DRAM botm	57 degrees C / 134 degrees F
FPC 1 EA2_HMC2 Logic die	65 degrees C / 149 degrees F
FPC 1 EA2_HMC2 DRAM botm	62 degrees C / 143 degrees F

Power

LTC3887-PF-VDD0V9-RAIL	899 mV
LTC3887-PF-VDD0V9-DEV0-	899 mV
LTC3887-PF-VDD0V9-DEV0-	901 mV
LTC3887-PF-VDD0V9-DEV1-	899 mV
LTC3887-PF-VDD0V9-DEV1-	901 mV
LTC3887-PF-AVDD1V0-RAIL	998 mV
LTC3887-PF-AVDD1V0-CH0	998 mV
LTC3887-PF-AVDD1V0-CH1	999 mV
LTC3887-ETHSW-VDD1V0	999 mV
LTC3887-VDD2V5	2499 mV
LTC3887-PCIE-VDD0V9	900 mV
LTC3887-V1P0	1000 mV
LTC3887-PHY-VDD1V0-A	1000 mV
LTC3887-3V3	3300 mV
LTC3887-VDD1V8	1799 mV
UCD9090_0-CH_1-EA0_PLL_	1004 mV
UCD9090_0-CH_2-EA0_1V4	1004 mV
UCD9090_0-CH_3-EA0_2V5	2499 mV

UCD9090_0-CH_4-EA0_1V5	1511 mV
UCD9090_0-CH_5-EA1_PLL_	999 mV
UCD9090_0-CH_6-EA1_1V4	1008 mV
UCD9090_0-CH_7-EA1_2V5	2499 mV
UCD9090_0-CH_8-EA1_1V5	1510 mV
UCD9090_0-CH_9-PVCC	839 mV
UCD9090_0-CH_10-PVNN	1016 mV
UCD9090_1-CH_1-EA2_PLL_	1011 mV
UCD9090_1-CH_2-EA2_1V4	1046 mV
UCD9090_1-CH_3-EA2_2V5	2499 mV
UCD9090_1-CH_4-EA2_1V5	1501 mV
UCD9090_1-CH_5-1V0_PFP	1000 mV
UCD9090_1-CH_6-V1P1	1037 mV
UCD9090_1-CH_7-V1P5	1530 mV
UCD9090_1-CH_8-V1P35	1360 mV
UCD9090_1-CH_9-VDD1V5	1513 mV
UCD9090_1-CH_10-VDD1V2	1217 mV
LTC3887-EA0-VDD0V9-RAIL	949 mV
LTC3887-EA0-VDD0V9-DEV0	949 mV
LTC3887-EA0-VDD0V9-DEV0	951 mV
LTC3887-EA0-VDD0V9-DEV1	949 mV
LTC3887-EA0-VDD0V9-DEV1	952 mV
LTC3887-EA0-VDD0V9R2-RA	947 mV
LTC3887-EA0-VDD0V9R2-CH	947 mV
LTC3887-EA0-VDD0V9R2-CH	949 mV
LTC3887-EA0-VDD1V0-RAIL	1000 mV
LTC3887-EA0-VDD1V0-CH0	1000 mV
LTC3887-EA0-VDD1V0-CH1	1001 mV
LTC3887-EA0-XR-VDD0V9	899 mV
LTC3887-EA0-XR-VDD1V2	1200 mV
LTC3887-EA0-HM1-VDD0V9	899 mV
LTC3887-EA0-HM-VDD1V2	1199 mV
LTC3887-EA0-HM-VDDM1V2	1199 mV
LTC3887-EA1-VDD0V9-RAIL	948 mV
LTC3887-EA1-VDD0V9-DEV0	950 mV
LTC3887-EA1-VDD0V9-DEV0	950 mV
LTC3887-EA1-VDD0V9-DEV1	951 mV
LTC3887-EA1-VDD0V9-DEV1	951 mV
LTC3887-EA1-VDD0V9R2-RA	947 mV
LTC3887-EA1-VDD0V9R2-CH	947 mV
LTC3887-EA1-VDD0V9R2-CH	949 mV
LTC3887-EA1-VDD1V0-RAIL	1000 mV
LTC3887-EA1-VDD1V0-CH0	1000 mV

```
LTC3887-EA1-VDD1V0-CH1    1002 mV
I2C Slave Revision        99
```

show chassis environment fpc (MX204 Router)

```
user@host> show chassis environment fpc
```

```
FPC 0 status:
```

```
State                Online
FPC 0 EA0_HMC0 Logic die  77 degrees C / 170 degrees F
FPC 0 EA0_HMC0 DRAM botm  74 degrees C / 165 degrees F
FPC 0 EA0_HMC1 Logic die  80 degrees C / 176 degrees F
FPC 0 EA0_HMC1 DRAM botm  77 degrees C / 170 degrees F
FPC 0 EA0 Chip           93 degrees C / 199 degrees F
FPC 0 EA0-XR0 Chip       63 degrees C / 145 degrees F
FPC 0 EA0-XR1 Chip       64 degrees C / 147 degrees F
Power
I2C Slave Revision      0
```

show chassis environment fpc (MX10008 Router)

```
user@host> show chassis environment fpc
```

```
FPC 0 status:
```

```
State                Online
FPC 0 Intake-A Temp Sensor  32 degrees C / 89 degrees F
FPC 0 Exhaust-A Temp Sensor 44 degrees C / 111 degrees F
FPC 0 Exhaust-B Temp Sensor 50 degrees C / 122 degrees F
FPC 0 EA0 Temp Sensor       67 degrees C / 152 degrees F
FPC 0 EA0_XR0 Temp Sensor   69 degrees C / 156 degrees F
FPC 0 EA0_XR1 Temp Sensor   73 degrees C / 163 degrees F
FPC 0 EA1 Temp Sensor       61 degrees C / 141 degrees F
FPC 0 EA1_XR0 Temp Sensor   65 degrees C / 149 degrees F
FPC 0 EA1_XR1 Temp Sensor   63 degrees C / 145 degrees F
FPC 0 EA2 Temp Sensor       69 degrees C / 156 degrees F
FPC 0 EA2_XR0 Temp Sensor   73 degrees C / 163 degrees F
FPC 0 EA2_XR1 Temp Sensor   72 degrees C / 161 degrees F
FPC 0 EA3 Temp Sensor       64 degrees C / 147 degrees F
FPC 0 EA3_XR0 Temp Sensor   66 degrees C / 150 degrees F
FPC 0 EA3_XR1 Temp Sensor   66 degrees C / 150 degrees F
```

FPC 0 EA4 Temp Sensor	70 degrees C / 158 degrees F
FPC 0 EA4_XR0 Temp Sensor	72 degrees C / 161 degrees F
FPC 0 EA4_XR1 Temp Sensor	72 degrees C / 161 degrees F
FPC 0 EA5 Temp Sensor	58 degrees C / 136 degrees F
FPC 0 EA5_XR0 Temp Sensor	61 degrees C / 141 degrees F
FPC 0 EA5_XR1 Temp Sensor	64 degrees C / 147 degrees F
FPC 0 EA0_HMC0 Logic die	75 degrees C / 167 degrees F
FPC 0 EA0_HMC0 DRAM botm	72 degrees C / 161 degrees F
FPC 0 EA0_HMC1 Logic die	76 degrees C / 168 degrees F
FPC 0 EA0_HMC1 DRAM botm	73 degrees C / 163 degrees F
FPC 0 EA0_HMC2 Logic die	77 degrees C / 170 degrees F
FPC 0 EA0_HMC2 DRAM botm	74 degrees C / 165 degrees F
FPC 0 EA1_HMC0 Logic die	72 degrees C / 161 degrees F
FPC 0 EA1_HMC0 DRAM botm	69 degrees C / 156 degrees F
FPC 0 EA1_HMC1 Logic die	73 degrees C / 163 degrees F
FPC 0 EA1_HMC1 DRAM botm	70 degrees C / 158 degrees F
FPC 0 EA1_HMC2 Logic die	72 degrees C / 161 degrees F
FPC 0 EA1_HMC2 DRAM botm	69 degrees C / 156 degrees F
FPC 0 EA2_HMC0 Logic die	80 degrees C / 176 degrees F
FPC 0 EA2_HMC0 DRAM botm	77 degrees C / 170 degrees F
FPC 0 EA2_HMC1 Logic die	81 degrees C / 177 degrees F
FPC 0 EA2_HMC1 DRAM botm	78 degrees C / 172 degrees F
FPC 0 EA2_HMC2 Logic die	80 degrees C / 176 degrees F
FPC 0 EA2_HMC2 DRAM botm	77 degrees C / 170 degrees F
FPC 0 EA3_HMC0 Logic die	77 degrees C / 170 degrees F
FPC 0 EA3_HMC0 DRAM botm	74 degrees C / 165 degrees F
FPC 0 EA3_HMC1 Logic die	78 degrees C / 172 degrees F
FPC 0 EA3_HMC1 DRAM botm	75 degrees C / 167 degrees F
FPC 0 EA3_HMC2 Logic die	77 degrees C / 170 degrees F
FPC 0 EA3_HMC2 DRAM botm	74 degrees C / 165 degrees F
FPC 0 EA4_HMC0 Logic die	80 degrees C / 176 degrees F
FPC 0 EA4_HMC0 DRAM botm	77 degrees C / 170 degrees F
FPC 0 EA4_HMC1 Logic die	81 degrees C / 177 degrees F
FPC 0 EA4_HMC1 DRAM botm	78 degrees C / 172 degrees F
FPC 0 EA4_HMC2 Logic die	80 degrees C / 176 degrees F
FPC 0 EA4_HMC2 DRAM botm	77 degrees C / 170 degrees F
FPC 0 EA5_HMC0 Logic die	69 degrees C / 156 degrees F
FPC 0 EA5_HMC0 DRAM botm	66 degrees C / 150 degrees F
FPC 0 EA5_HMC1 Logic die	68 degrees C / 154 degrees F
FPC 0 EA5_HMC1 DRAM botm	65 degrees C / 149 degrees F
FPC 0 EA5_HMC2 Logic die	68 degrees C / 154 degrees F
FPC 0 EA5_HMC2 DRAM botm	65 degrees C / 149 degrees F

Power

12V SS 1	12259 mV	9841 mA	120642 mW
12V SS 2	12259 mV	21054 mA	258104 mW
12V SS 3	12285 mV	9841 mA	120902 mW
12V SS 4	12232 mV	20968 mA	256496 mW
12V SS 5	12179 mV	14993 mA	182614 mW
VDD 1.0V_A	1000 mV	95375 mA	95375 mW
VDD 1.0V_B	0 mV	0 mA	0 mW
VDD 3.3V	3298 mV	12500 mA	41235 mW
VDD 0.9V	894 mV	3569 mA	3192 mW
ETH SW 1V	980 mV	4500 mA	4410 mW
VDD 1.8V	1809 mV	895 mA	1619 mW
PVCC	951 mV	0 mA	0 mW
PVNN	1009 mV	0 mA	0 mW
V1P0	1006 mV	0 mA	0 mW
V1P1	1070 mV	0 mA	0 mW
V1P3	1351 mV	0 mA	0 mW
VDDQ	1500 mV	0 mA	0 mW
V1P8	1816 mV	0 mA	0 mW
VDD3V3	3296 mV	0 mA	0 mW
V5V0_BIAS	5025 mV	0 mA	0 mW
VDD12V0	12174 mV	0 mA	0 mW
EA0 Core 0.9V	900 mV	40625 mA	36578 mW
EA0 AVDD 1.0V	1000 mV	32500 mA	32500 mW
EA0 HMC Core 0.9V	894 mV	10081 mA	9017 mW
EA0 1.2V	1189 mV	15081 mA	17945 mW
EA01_HMC_VDDM 1.2V	1193 mV	-151 mA	-180 mW
EA0_XR 0.906V	905 mV	13802 mA	12496 mW
EA1 Core 0.9V	900 mV	41000 mA	36916 mW
EA1 AVDD 1.0V	1000 mV	28000 mA	28000 mW
EA1 HMC Core 0.9V	897 mV	9848 mA	8835 mW
EA1 1.2V	1197 mV	15313 mA	18332 mW
EA0_PLL_1V0	1003 mV	0 mA	0 mW
EA0_1V04	1032 mV	0 mA	0 mW
EA0_2V5	2445 mV	0 mA	0 mW
EA0_1V5	1512 mV	0 mA	0 mW
EA1_PLL_1V0	1000 mV	0 mA	0 mW
EA1_1V04	1051 mV	0 mA	0 mW
EA1_2V5	2516 mV	0 mA	0 mW
EA1_1V5	1503 mV	0 mA	0 mW
EA1_XR 0.906V	908 mV	14151 mA	12850 mW
EA2 Core 0.9V	899 mV	40625 mA	36538 mW
EA2 AVDD 1.0V	1000 mV	27250 mA	27276 mW
EA2 HMC Core 0.9V	897 mV	9616 mA	8627 mW

EA2 1.2V	1193 mV	15779 mA	18832 mW
EA23_HMC_VDDM 1.2V	1197 mV	81 mA	97 mW
EA2_XR 0.906V	908 mV	14848 mA	13484 mW
EA3 Core 0.9V	899 mV	40625 mA	36538 mW
EA3 AVDD 1.0V	1000 mV	28000 mA	28000 mW
EA3 HMC Core 0.9V	897 mV	10546 mA	9461 mW
EA3 1.2V	1197 mV	15895 mA	19028 mW
EA2_PLL_1V0	1025 mV	0 mA	0 mW
EA2_1V04	1048 mV	0 mA	0 mW
EA2_2V5	2516 mV	0 mA	0 mW
EA2_1V5	1500 mV	0 mA	0 mW
EA3_PLL_1V0	1009 mV	0 mA	0 mW
EA3_1V04	1032 mV	0 mA	0 mW
EA3_2V5	2551 mV	0 mA	0 mW
EA3_1V5	1496 mV	0 mA	0 mW
EA3_XR 0.906V	908 mV	15895 mA	14434 mW
EA4 Core 0.9V	900 mV	41000 mA	36916 mW
EA4 AVDD 1.0V	999 mV	31250 mA	31219 mW
EA4 HMC Core 0.9V	894 mV	9965 mA	8913 mW
EA4 1.2V	1197 mV	15779 mA	18889 mW
EA45_HMC_VDDM 1.2V	1197 mV	546 mA	654 mW
EA4_XR 0.906V	908 mV	15197 mA	13801 mW
EA5 Core 0.9V	900 mV	39750 mA	35790 mW
EA5 AVDD 1.0V	1000 mV	28000 mA	28000 mW
EA5 HMC Core 0.9V	897 mV	9965 mA	8940 mW
EA5 1.2V	1197 mV	15546 mA	18610 mW
EA4_PLL_1V0	1003 mV	0 mA	0 mW
EA4_1V04	1041 mV	0 mA	0 mW
EA4_2V5	2541 mV	0 mA	0 mW
EA4_1V5	1506 mV	0 mA	0 mW
EA5_PLL_1V0	1022 mV	0 mA	0 mW
EA5_1V04	1048 mV	0 mA	0 mW
EA5_2V5	2532 mV	0 mA	0 mW
EA5_1V5	1509 mV	0 mA	0 mW
VDD2V5	2503 mV	0 mA	0 mW
VDD1V5	1509 mV	0 mA	0 mW
VDD1V2	1206 mV	0 mA	0 mW
EA5_XR 0.906V	902 mV	14500 mA	13088 mW

FPC 2 status:

State	Online
FPC 2 Intake-A Temp Sensor	33 degrees C / 91 degrees F
FPC 2 Exhaust-A Temp Sensor	52 degrees C / 125 degrees F
FPC 2 Exhaust-B Temp Sensor	50 degrees C / 122 degrees F

FPC 2 EA0 Temp Sensor	72 degrees C / 161 degrees F
FPC 2 EA0_XR0 Temp Sensor	76 degrees C / 168 degrees F
FPC 2 EA0_XR1 Temp Sensor	79 degrees C / 174 degrees F
FPC 2 EA1 Temp Sensor	64 degrees C / 147 degrees F
FPC 2 EA1_XR0 Temp Sensor	68 degrees C / 154 degrees F
FPC 2 EA1_XR1 Temp Sensor	66 degrees C / 150 degrees F
FPC 2 EA2 Temp Sensor	75 degrees C / 167 degrees F
FPC 2 EA2_XR0 Temp Sensor	81 degrees C / 177 degrees F
FPC 2 EA2_XR1 Temp Sensor	81 degrees C / 177 degrees F
FPC 2 EA3 Temp Sensor	67 degrees C / 152 degrees F
FPC 2 EA3_XR0 Temp Sensor	69 degrees C / 156 degrees F
FPC 2 EA3_XR1 Temp Sensor	69 degrees C / 156 degrees F
FPC 2 EA4 Temp Sensor	76 degrees C / 168 degrees F
FPC 2 EA4_XR0 Temp Sensor	77 degrees C / 170 degrees F
FPC 2 EA4_XR1 Temp Sensor	76 degrees C / 168 degrees F
FPC 2 EA5 Temp Sensor	60 degrees C / 140 degrees F
FPC 2 EA5_XR0 Temp Sensor	65 degrees C / 149 degrees F
FPC 2 EA5_XR1 Temp Sensor	65 degrees C / 149 degrees F
FPC 2 EA0_HMC0 Logic die	84 degrees C / 183 degrees F
FPC 2 EA0_HMC0 DRAM botm	81 degrees C / 177 degrees F
FPC 2 EA0_HMC1 Logic die	86 degrees C / 186 degrees F
FPC 2 EA0_HMC1 DRAM botm	83 degrees C / 181 degrees F
FPC 2 EA0_HMC2 Logic die	83 degrees C / 181 degrees F
FPC 2 EA0_HMC2 DRAM botm	80 degrees C / 176 degrees F
FPC 2 EA1_HMC0 Logic die	76 degrees C / 168 degrees F
FPC 2 EA1_HMC0 DRAM botm	73 degrees C / 163 degrees F
FPC 2 EA1_HMC1 Logic die	77 degrees C / 170 degrees F
FPC 2 EA1_HMC1 DRAM botm	74 degrees C / 165 degrees F
FPC 2 EA1_HMC2 Logic die	76 degrees C / 168 degrees F
FPC 2 EA1_HMC2 DRAM botm	73 degrees C / 163 degrees F
FPC 2 EA2_HMC0 Logic die	87 degrees C / 188 degrees F
FPC 2 EA2_HMC0 DRAM botm	84 degrees C / 183 degrees F
FPC 2 EA2_HMC1 Logic die	89 degrees C / 192 degrees F
FPC 2 EA2_HMC1 DRAM botm	86 degrees C / 186 degrees F
FPC 2 EA2_HMC2 Logic die	88 degrees C / 190 degrees F
FPC 2 EA2_HMC2 DRAM botm	85 degrees C / 185 degrees F
FPC 2 EA3_HMC0 Logic die	80 degrees C / 176 degrees F
FPC 2 EA3_HMC0 DRAM botm	77 degrees C / 170 degrees F
FPC 2 EA3_HMC1 Logic die	81 degrees C / 177 degrees F
FPC 2 EA3_HMC1 DRAM botm	78 degrees C / 172 degrees F
FPC 2 EA3_HMC2 Logic die	81 degrees C / 177 degrees F
FPC 2 EA3_HMC2 DRAM botm	78 degrees C / 172 degrees F
FPC 2 EA4_HMC0 Logic die	88 degrees C / 190 degrees F

FPC 2 EA4_HMC0 DRAM botm	85 degrees C / 185 degrees F
FPC 2 EA4_HMC1 Logic die	90 degrees C / 194 degrees F
FPC 2 EA4_HMC1 DRAM botm	87 degrees C / 188 degrees F
FPC 2 EA4_HMC2 Logic die	81 degrees C / 177 degrees F
FPC 2 EA4_HMC2 DRAM botm	78 degrees C / 172 degrees F
FPC 2 EA5_HMC0 Logic die	73 degrees C / 163 degrees F
FPC 2 EA5_HMC0 DRAM botm	70 degrees C / 158 degrees F
FPC 2 EA5_HMC1 Logic die	69 degrees C / 156 degrees F
FPC 2 EA5_HMC1 DRAM botm	66 degrees C / 150 degrees F
FPC 2 EA5_HMC2 Logic die	73 degrees C / 163 degrees F
FPC 2 EA5_HMC2 DRAM botm	70 degrees C / 158 degrees F

Power

12V SS 1	12285 mV	9408 mA	115582 mW
12V SS 2	12338 mV	20881 mA	257637 mW
12V SS 3	12351 mV	10317 mA	127430 mW
12V SS 4	12285 mV	21054 mA	258660 mW
12V SS 5	12153 mV	13954 mA	169591 mW
VDD 1.0V_A	1000 mV	91000 mA	91000 mW
VDD 1.0V_B	0 mV	0 mA	0 mW
VDD 3.3V	3298 mV	9125 mA	30101 mW
VDD 0.9V	897 mV	3337 mA	2993 mW
ETH SW 1V	0 mV	0 mA	0 mW
VDD 1.8V	1809 mV	1127 mA	2040 mW
PVCC	835 mV	0 mA	0 mW
PVNN	1000 mV	0 mA	0 mW
V1P0	1003 mV	0 mA	0 mW
V1P1	1070 mV	0 mA	0 mW
V1P3	1348 mV	0 mA	0 mW
VDDQ	1493 mV	0 mA	0 mW
V1P8	1806 mV	0 mA	0 mW
VDD3V3	3303 mV	0 mA	0 mW
V5V0_BIAS	5000 mV	0 mA	0 mW
VDD12V0	12116 mV	0 mA	0 mW
EA0 Core 0.9V	900 mV	38875 mA	35002 mW
EA0 AVDD 1.0V	999 mV	31875 mA	31843 mW
EA0 HMC Core 0.9V	894 mV	9034 mA	8081 mW
EA0 1.2V	1197 mV	15430 mA	18471 mW
EA01_HMC_VDDM 1.2V	1200 mV	-267 mA	-321 mW
EA0_XR 0.906V	908 mV	15430 mA	14012 mW
EA1 Core 0.9V	900 mV	38875 mA	35002 mW
EA1 AVDD 1.0V	1000 mV	28250 mA	28250 mW
EA1 HMC Core 0.9V	899 mV	8802 mA	7920 mW
EA1 1.2V	1197 mV	15081 mA	18054 mW

EA0_PLL_1V0	1003 mV	0 mA	0 mW
EA0_1V04	1048 mV	0 mA	0 mW
EA0_2V5	2425 mV	0 mA	0 mW
EA0_1V5	1483 mV	0 mA	0 mW
EA1_PLL_1V0	1019 mV	0 mA	0 mW
EA1_1V04	1019 mV	0 mA	0 mW
EA1_2V5	2490 mV	0 mA	0 mW
EA1_1V5	1480 mV	0 mA	0 mW
EA1_XR 0.906V	908 mV	14965 mA	13590 mW
EA2 Core 0.9V	900 mV	44000 mA	39617 mW
EA2 AVDD 1.0V	1000 mV	28625 mA	28625 mW
EA2 HMC Core 0.9V	891 mV	10546 mA	9404 mW
EA2 1.2V	1200 mV	15313 mA	18387 mW
EA23_HMC_VDDM 1.2V	1193 mV	-267 mA	-319 mW
EA2_XR 0.906V	908 mV	15197 mA	13801 mW
EA3 Core 0.9V	900 mV	39750 mA	35790 mW
EA3 AVDD 1.0V	1000 mV	27750 mA	27750 mW
EA3 HMC Core 0.9V	897 mV	9267 mA	8314 mW
EA3 1.2V	1197 mV	15430 mA	18471 mW
EA2_PLL_1V0	1009 mV	0 mA	0 mW
EA2_1V04	1041 mV	0 mA	0 mW
EA2_2V5	2496 mV	0 mA	0 mW
EA2_1V5	1493 mV	0 mA	0 mW
EA3_PLL_1V0	1003 mV	0 mA	0 mW
EA3_1V04	1041 mV	0 mA	0 mW
EA3_2V5	2490 mV	0 mA	0 mW
EA3_1V5	1500 mV	0 mA	0 mW
EA3_XR 0.906V	908 mV	15081 mA	13695 mW
EA4 Core 0.9V	899 mV	45750 mA	41148 mW
EA4 AVDD 1.0V	1000 mV	32250 mA	32250 mW
EA4 HMC Core 0.9V	897 mV	10779 mA	9670 mW
EA4 1.2V	1193 mV	16011 mA	19110 mW
EA45_HMC_VDDM 1.2V	1200 mV	-267 mA	-321 mW
EA4_XR 0.906V	905 mV	15779 mA	14286 mW
EA5 Core 0.9V	900 mV	38375 mA	34552 mW
EA5 AVDD 1.0V	1000 mV	27750 mA	27777 mW
EA5 HMC Core 0.9V	899 mV	8453 mA	7606 mW
EA5 1.2V	1200 mV	14732 mA	17689 mW
EA4_PLL_1V0	1012 mV	0 mA	0 mW
EA4_1V04	1029 mV	0 mA	0 mW
EA4_2V5	2496 mV	0 mA	0 mW
EA4_1V5	1490 mV	0 mA	0 mW
EA5_PLL_1V0	1003 mV	0 mA	0 mW

EA5_1V04	1032 mV	0 mA	0 mW
EA5_2V5	2503 mV	0 mA	0 mW
EA5_1V5	1480 mV	0 mA	0 mW
VDD2V5	2461 mV	0 mA	0 mW
VDD1V5	1490 mV	0 mA	0 mW
VDD1V2	1212 mV	0 mA	0 mW
EA5_XR 0.906V	910 mV	13686 mA	12466 mW

FPC 3 status:

State	Online
FPC 3 Intake-A Temp Sensor	30 degrees C / 86 degrees F
FPC 3 Exhaust-A Temp Sensor	48 degrees C / 118 degrees F
FPC 3 Exhaust-B Temp Sensor	45 degrees C / 113 degrees F
FPC 3 EA0 Temp Sensor	60 degrees C / 140 degrees F
FPC 3 EA0_XR0 Temp Sensor	65 degrees C / 149 degrees F
FPC 3 EA0_XR1 Temp Sensor	67 degrees C / 152 degrees F
FPC 3 EA1 Temp Sensor	54 degrees C / 129 degrees F
FPC 3 EA1_XR0 Temp Sensor	60 degrees C / 140 degrees F
FPC 3 EA1_XR1 Temp Sensor	58 degrees C / 136 degrees F
FPC 3 EA2 Temp Sensor	62 degrees C / 143 degrees F
FPC 3 EA2_XR0 Temp Sensor	67 degrees C / 152 degrees F
FPC 3 EA2_XR1 Temp Sensor	67 degrees C / 152 degrees F
FPC 3 EA3 Temp Sensor	55 degrees C / 131 degrees F
FPC 3 EA3_XR0 Temp Sensor	57 degrees C / 134 degrees F
FPC 3 EA3_XR1 Temp Sensor	57 degrees C / 134 degrees F
FPC 3 EA4 Temp Sensor	69 degrees C / 156 degrees F
FPC 3 EA4_XR0 Temp Sensor	71 degrees C / 159 degrees F
FPC 3 EA4_XR1 Temp Sensor	70 degrees C / 158 degrees F
FPC 3 EA5 Temp Sensor	55 degrees C / 131 degrees F
FPC 3 EA5_XR0 Temp Sensor	58 degrees C / 136 degrees F
FPC 3 EA5_XR1 Temp Sensor	59 degrees C / 138 degrees F
FPC 3 EA0_HMC0 Logic die	69 degrees C / 156 degrees F
FPC 3 EA0_HMC0 DRAM botm	66 degrees C / 150 degrees F
FPC 3 EA0_HMC1 Logic die	70 degrees C / 158 degrees F
FPC 3 EA0_HMC1 DRAM botm	67 degrees C / 152 degrees F
FPC 3 EA0_HMC2 Logic die	70 degrees C / 158 degrees F
FPC 3 EA0_HMC2 DRAM botm	67 degrees C / 152 degrees F
FPC 3 EA1_HMC0 Logic die	68 degrees C / 154 degrees F
FPC 3 EA1_HMC0 DRAM botm	65 degrees C / 149 degrees F
FPC 3 EA1_HMC1 Logic die	65 degrees C / 149 degrees F
FPC 3 EA1_HMC1 DRAM botm	62 degrees C / 143 degrees F
FPC 3 EA1_HMC2 Logic die	64 degrees C / 147 degrees F
FPC 3 EA1_HMC2 DRAM botm	61 degrees C / 141 degrees F
FPC 3 EA2_HMC0 Logic die	74 degrees C / 165 degrees F

FPC 3 EA2_HMC0 DRAM botm	71 degrees C / 159 degrees F
FPC 3 EA2_HMC1 Logic die	77 degrees C / 170 degrees F
FPC 3 EA2_HMC1 DRAM botm	74 degrees C / 165 degrees F
FPC 3 EA2_HMC2 Logic die	74 degrees C / 165 degrees F
FPC 3 EA2_HMC2 DRAM botm	71 degrees C / 159 degrees F
FPC 3 EA3_HMC0 Logic die	70 degrees C / 158 degrees F
FPC 3 EA3_HMC0 DRAM botm	67 degrees C / 152 degrees F
FPC 3 EA3_HMC1 Logic die	68 degrees C / 154 degrees F
FPC 3 EA3_HMC1 DRAM botm	65 degrees C / 149 degrees F
FPC 3 EA3_HMC2 Logic die	68 degrees C / 154 degrees F
FPC 3 EA3_HMC2 DRAM botm	65 degrees C / 149 degrees F
FPC 3 EA4_HMC0 Logic die	82 degrees C / 179 degrees F
FPC 3 EA4_HMC0 DRAM botm	79 degrees C / 174 degrees F
FPC 3 EA4_HMC1 Logic die	80 degrees C / 176 degrees F
FPC 3 EA4_HMC1 DRAM botm	77 degrees C / 170 degrees F
FPC 3 EA4_HMC2 Logic die	81 degrees C / 177 degrees F
FPC 3 EA4_HMC2 DRAM botm	78 degrees C / 172 degrees F
FPC 3 EA5_HMC0 Logic die	69 degrees C / 156 degrees F
FPC 3 EA5_HMC0 DRAM botm	66 degrees C / 150 degrees F
FPC 3 EA5_HMC1 Logic die	70 degrees C / 158 degrees F
FPC 3 EA5_HMC1 DRAM botm	67 degrees C / 152 degrees F
FPC 3 EA5_HMC2 Logic die	69 degrees C / 156 degrees F
FPC 3 EA5_HMC2 DRAM botm	66 degrees C / 150 degrees F

Power

12V SS 1	12259 mV	9538 mA	116927 mW
12V SS 2	12259 mV	20491 mA	251202 mW
12V SS 3	12298 mV	9711 mA	119433 mW
12V SS 4	12219 mV	20491 mA	250391 mW
12V SS 5	12206 mV	10447 mA	127520 mW
VDD 1.0V_A	1000 mV	42250 mA	42291 mW
VDD 1.0V_B	996 mV	8918 mA	8890 mW
VDD 3.3V	3301 mV	10375 mA	34255 mW
VDD 0.9V	897 mV	3569 mA	3202 mW
ETH SW 1V	983 mV	4267 mA	4195 mW
VDD 1.8V	1812 mV	1825 mA	3309 mW
PVCC	974 mV	0 mA	0 mW
PVNN	1003 mV	0 mA	0 mW
V1P0	1003 mV	0 mA	0 mW
V1P1	1070 mV	0 mA	0 mW
V1P3	1351 mV	0 mA	0 mW
VDDQ	1496 mV	0 mA	0 mW
V1P8	1809 mV	0 mA	0 mW
VDD3V3	3309 mV	0 mA	0 mW

V5V0_BIAS	4987 mV	0 mA	0 mW
VDD12V0	12212 mV	0 mA	0 mW
EA0 Core 0.9V	900 mV	38125 mA	34327 mW
EA0 AVDD 1.0V	999 mV	31125 mA	31094 mW
EA0 HMC Core 0.9V	897 mV	9500 mA	8522 mW
EA0 1.2V	1193 mV	15430 mA	18416 mW
EA01_HMC_VDDM 1.2V	1193 mV	313 mA	374 mW
EA0_XR 0.906V	913 mV	14965 mA	13671 mW
EA1 Core 0.9V	900 mV	39750 mA	35790 mW
EA1 AVDD 1.0V	1000 mV	26000 mA	26000 mW
EA1 HMC Core 0.9V	897 mV	8918 mA	8001 mW
EA1 1.2V	1200 mV	15779 mA	18946 mW
EA0_PLL_1V0	1003 mV	0 mA	0 mW
EA0_1V04	1019 mV	0 mA	0 mW
EA0_2V5	2448 mV	0 mA	0 mW
EA0_1V5	1470 mV	0 mA	0 mW
EA1_PLL_1V0	1016 mV	0 mA	0 mW
EA1_1V04	1035 mV	0 mA	0 mW
EA1_2V5	2506 mV	0 mA	0 mW
EA1_1V5	1483 mV	0 mA	0 mW
EA1_XR 0.906V	908 mV	13918 mA	12639 mW
EA2 Core 0.9V	900 mV	38625 mA	34777 mW
EA2 AVDD 1.0V	1000 mV	26375 mA	26400 mW
EA2 HMC Core 0.9V	897 mV	9383 mA	8418 mW
EA2 1.2V	1200 mV	15779 mA	18946 mW
EA23_HMC_VDDM 1.2V	1193 mV	81 mA	97 mW
EA2_XR 0.906V	908 mV	13918 mA	12639 mW
EA3 Core 0.9V	899 mV	40250 mA	36201 mW
EA3 AVDD 1.0V	1000 mV	26750 mA	26776 mW
EA3 HMC Core 0.9V	894 mV	9267 mA	8289 mW
EA3 1.2V	1197 mV	16127 mA	19306 mW
EA2_PLL_1V0	993 mV	0 mA	0 mW
EA2_1V04	1045 mV	0 mA	0 mW
EA2_2V5	2474 mV	0 mA	0 mW
EA2_1V5	1490 mV	0 mA	0 mW
EA3_PLL_1V0	980 mV	0 mA	0 mW
EA3_1V04	1032 mV	0 mA	0 mW
EA3_2V5	2506 mV	0 mA	0 mW
EA3_1V5	1474 mV	0 mA	0 mW
EA3_XR 0.906V	910 mV	14732 mA	13419 mW
EA4 Core 0.9V	900 mV	42500 mA	38266 mW
EA4 AVDD 1.0V	1000 mV	32250 mA	32281 mW
EA4 HMC Core 0.9V	899 mV	10081 mA	9071 mW

EA4 1.2V	1193 mV	16360 mA	19526 mW
EA45_HMC_VDDM 1.2V	1193 mV	662 mA	791 mW
EA4_XR 0.906V	908 mV	15430 mA	14012 mW
EA5 Core 0.9V	899 mV	37000 mA	33278 mW
EA5 AVDD 1.0V	1000 mV	26125 mA	26150 mW
EA5 HMC Core 0.9V	897 mV	9267 mA	8314 mW
EA5 1.2V	1197 mV	15662 mA	18750 mW
EA4_PLL_1V0	1000 mV	0 mA	0 mW
EA4_1V04	1029 mV	0 mA	0 mW
EA4_2V5	2487 mV	0 mA	0 mW
EA4_1V5	1496 mV	0 mA	0 mW
EA5_PLL_1V0	1009 mV	0 mA	0 mW
EA5_1V04	1032 mV	0 mA	0 mW
EA5_2V5	2503 mV	0 mA	0 mW
EA5_1V5	1496 mV	0 mA	0 mW
VDD2V5	2483 mV	0 mA	0 mW
VDD1V5	1470 mV	0 mA	0 mW
VDD1V2	1203 mV	0 mA	0 mW
EA5_XR 0.906V	908 mV	14500 mA	13167 mW

show chassis environment fpc (T320, T640, and T1600 Routers)

```

user@host> show chassis environment fpc
FPC 0 status:
  State                Online
  Temperature Top      42 degrees C / 107 degrees F
  Temperature Bottom   36 degrees C / 96 degrees F
  Temperature MMB1     39 degrees C / 102 degrees F
Power:
  1.8 V                1959 mV
  2.5 V                2495 mV
  3.3 V                3344 mV
  5.0 V                5047 mV
  1.8 V bias           1787 mV
  3.3 V bias           3291 mV
  5.0 V bias           4998 mV
  8.0 V bias           7343 mV
  BUS Revision         40
FPC 1 status:
  State                Online
  Temperature Top      42 degrees C / 107 degrees F

```



```

Temperature Bottom      39 degrees C / 102 degrees F
Temperature MMB1       40 degrees C / 104 degrees F
Power:
  1.8 V                 1956 mV
  2.5 V                 2498 mV
  3.3 V                 3340 mV
  5.0 V                 5023 mV
  1.8 V bias           1782 mV
  3.3 V bias           3277 mV
  5.0 V bias           4989 mV
  8.0 V bias           7289 mV
BUS Revision            40
FPC 2 status:
State                   Online
Temperature Top         43 degrees C / 109 degrees F
Temperature Bottom     39 degrees C / 102 degrees F
Temperature MMB1       41 degrees C / 105 degrees F
Power:
  1.8 V                 1963 mV
  2.5 V                 2503 mV
  3.3 V                 3340 mV
  5.0 V                 5042 mV
  1.8 V bias           1797 mV
  3.3 V bias           3311 mV
  5.0 V bias           5013 mV
  8.0 V bias           7221 mV
BUS Revision            40

```

show chassis environment fpc (T4000 Router)

```

user@host> show chassis environment fpc
FPC 0 status:
State                   Online
Fan Intake              34 degrees C / 93 degrees F
Fan Exhaust             48 degrees C / 118 degrees F
PMB                     47 degrees C / 116 degrees F
LMB0                    50 degrees C / 122 degrees F
LMB1                    41 degrees C / 105 degrees F
LMB2                    35 degrees C / 95 degrees F
PFE1 LU2                46 degrees C / 114 degrees F
PFE1 LU0                41 degrees C / 105 degrees F

```

PFE0 LU0	57 degrees C / 134 degrees F
XF1	47 degrees C / 116 degrees F
XF0	52 degrees C / 125 degrees F
XM1	41 degrees C / 105 degrees F
XM0	50 degrees C / 122 degrees F
PFE0 LU1	56 degrees C / 132 degrees F
PFE0 LU2	45 degrees C / 113 degrees F
PFE1 LU1	37 degrees C / 98 degrees F
Power 1	
1.0 V	991 mV
1.2 V bias	1195 mV
1.8 V	1788 mV
2.5 V	2483 mV
3.3 V	3289 mV
3.3 V bias	3299 mV
12.0 V A	10608 mV
12.0 V B	10637 mV
Power 2	
0.9 V	881 mV
0.9 V PFE0	916 mV
0.9 V PFE1	903 mV
1.0 V PFE0	1012 mV
1.0 V PFE1	1002 mV
1.1 V	1095 mV
1.5 V_0	1494 mV
1.5 V_1	1479 mV
Power 3	
1.0 V PFE0	1000 mV
1.0 V PFE1	1002 mV
1.0 V PFE0 *	995 mV
1.0 V PFE1 *	995 mV
1.8 V PFE 0	1788 mV
1.8 V PFE 1	1789 mV
2.5 V	2482 mV
12.0 V	11614 mV
Power 4	
1.0 V PFE0 LU0	1003 mV
1.0 V PFE1 LU0	1003 mV
1.0 V PFE1 LU2	1004 mV
1.0 V PFE0 LU0 *	995 mV
1.0 V PFE1 LU0 *	998 mV
1.0 V PFE1 LU2 *	996 mV
12.0 V	11643 mV

12.0 V C	11711 mV
Power (Base/PMB/MMB)	
LMB0 VDD2V5	2488 mV
LMB0 VDD1V8	1788 mV
LMB0 VDD1V5	1496 mV
LMB0 PFE0 LU0 AVDD1V0	1002 mV
LMB0 PFE0 LU0 VDD1V0	1000 mV
LMB0 VDD12V0	10752 mV
LMB1 VDD2V5	2472 mV
LMB1 VDD1V8	1792 mV
LMB1 VDD1V5	1480 mV
LMB1 PFE0 LU2 AVDD1V0	994 mV
LMB1 PFE0 LU2 VDD1V0	1002 mV
LMB1 VDD12V0	10800 mV
LMB2 VDD2V5	2472 mV
LMB2 VDD1V8	1792 mV
LMB2 VDD1V5	1486 mV
LMB2 PFE1 LU1 AVDD1V0	996 mV
LMB2 PFE1 LU1 VDD1V0	998 mV
LMB2 VDD12V0	10704 mV
PMB 1.05v	1049 mV
PMB 1.5v	1500 mV
PMB 2.5v	2500 mV
PMB 3.3v	3299 mV
Bus Revision	113
FPC 3 status:	
State	Online
Fan Intake	37 degrees C / 98 degrees F
Fan Exhaust	51 degrees C / 123 degrees F
PMB	43 degrees C / 109 degrees F
LMB0	57 degrees C / 134 degrees F
LMB1	54 degrees C / 129 degrees F
LMB2	38 degrees C / 100 degrees F
PFE1 LU2	63 degrees C / 145 degrees F
PFE1 LU0	45 degrees C / 113 degrees F
PFE0 LU0	69 degrees C / 156 degrees F
XF1	62 degrees C / 143 degrees F
XF0	63 degrees C / 145 degrees F
XM1	43 degrees C / 109 degrees F
XM0	67 degrees C / 152 degrees F
PFE0 LU1	63 degrees C / 145 degrees F
PFE0 LU2	66 degrees C / 150 degrees F
PFE1 LU1	41 degrees C / 105 degrees F

Power 1	
1.0 V	1002 mV
1.2 V bias	1201 mV
1.8 V	1785 mV
2.5 V	2485 mV
3.3 V	3288 mV
3.3 V bias	3285 mV
12.0 V A	10412 mV
12.0 V B	10515 mV
Power 2	
0.9 V	882 mV
0.9 V PFE0	920 mV
0.9 V PFE1	905 mV
1.0 V PFE0	1015 mV
1.0 V PFE1	1001 mV
1.1 V	1094 mV
1.5 V_0	1495 mV
1.5 V_1	1478 mV
Power 3	
0.92 V PFE1	998 mV
1.0 V PFE0	997 mV
1.0 V PFE0 *	992 mV
1.0 V PFE1 *	991 mV
1.8 V PFE 0	1780 mV
1.8 V PFE 1	1797 mV
2.5 V	2492 mV
12.0 V	11604 mV
Power 4	
1.0 V PFE0 LU0	1003 mV
1.0 V PFE1 LU0	1004 mV
1.0 V PFE1 LU2	1003 mV
1.0 V PFE0 LU0 *	1000 mV
1.0 V PFE1 LU0 *	1001 mV
1.0 V PFE1 LU2 *	1003 mV
12.0 V	11653 mV
12.0 V C	11672 mV
Power (Base/PMB/MMB)	
LMB0 VDD2V5	2512 mV
LMB0 VDD1V8	1790 mV
LMB0 VDD1V5	1500 mV
LMB0 PFE0 LU0 AVDD1V0	1004 mV
LMB0 PFE0 LU0 VDD1V0	1002 mV
LMB0 VDD12V0	10608 mV

LMB1 VDD2V5	2472 mV
LMB1 VDD1V8	1788 mV
LMB1 VDD1V5	1480 mV
LMB1 PFE0 LU2 AVDD1V0	1000 mV
LMB1 PFE0 LU2 VDD1V0	1004 mV
LMB1 VDD12V0	10672 mV
LMB2 VDD2V5	2488 mV
LMB2 VDD1V8	1798 mV
LMB2 VDD1V5	1494 mV
LMB2 PFE1 LU1 AVDD1V0	1000 mV
LMB2 PFE1 LU1 VDD1V0	1004 mV
LMB2 VDD12V0	10528 mV
PMB 1.05v	1050 mV
PMB 1.5v	1500 mV
PMB 2.5v	2499 mV
PMB 3.3v	3299 mV
Bus Revision	113
FPC 5 status:	
State	Online
Temperature Top	39 degrees C / 102 degrees F
Temperature Bottom	38 degrees C / 100 degrees F
Power	
1.8 V	1804 mV
1.8 V bias	1802 mV
3.3 V	3294 mV
3.3 V bias	3277 mV
5.0 V bias	5008 mV
5.0 V TOP	5067 mV
8.0 V bias	6642 mV
Power (Base/PMB/MMB)	
1.2 V	1202 mV
1.5 V	1504 mV
5.0 V BOT	5079 mV
12.0 V TOP Base	11848 mV
12.0 V BOT Base	11780 mV
1.1 V PMB	1111 mV
1.2 V PMB	1189 mV
1.5 V PMB	1494 mV
1.8 V PMB	1819 mV
2.5 V PMB	2503 mV
3.3 V PMB	3294 mV
5.0 V PMB	5035 mV
12.0 V PMB	11788 mV

0.75 V MMB TOP	766 mV
1.5 V MMB TOP	1484 mV
1.8 V MMB TOP	1772 mV
2.5 V MMB TOP	2485 mV
1.2 V MMB TOP	1137 mV
5.0 V MMB TOP	4946 mV
12.0 V MMB TOP	11772 mV
3.3 V MMB TOP	3289 mV
0.75 V MMB BOT	759 mV
1.5 V MMB BOT	1482 mV
1.8 V MMB BOT	1792 mV
2.5 V MMB BOT	2490 mV
1.2 V MMB BOT	1145 mV
5.0 V MMB BOT	4922 mV
12.0 V MMB BOT	11625 mV
3.3 V MMB BOT	3282 mV
APS 00	2495 mV
APS 01	3308 mV
APS 02	3301 mV
5.0 V PIC 0	4967 mV
APS 10	2512 mV
APS 11	3316 mV
APS 12	3304 mV
5.0 V PIC 1	5081 mV
Bus Revision	49
FPC 6 status:	
State	Online
Fan Intake	34 degrees C / 93 degrees F
Fan Exhaust	49 degrees C / 120 degrees F
PMB	40 degrees C / 104 degrees F
LMB0	60 degrees C / 140 degrees F
LMB1	58 degrees C / 136 degrees F
LMB2	40 degrees C / 104 degrees F
PFE1 LU2	69 degrees C / 156 degrees F
PFE1 LU0	45 degrees C / 113 degrees F
PFE0 LU0	71 degrees C / 159 degrees F
XF1	58 degrees C / 136 degrees F
XF0	65 degrees C / 149 degrees F
XM1	40 degrees C / 104 degrees F
XM0	66 degrees C / 150 degrees F
PFE0 LU1	69 degrees C / 156 degrees F
PFE0 LU2	68 degrees C / 154 degrees F
PFE1 LU1	42 degrees C / 107 degrees F

Power 1	
1.0 V	998 mV
1.2 V bias	1191 mV
1.8 V	1781 mV
2.5 V	2487 mV
3.3 V	3302 mV
3.3 V bias	3300 mV
12.0 V A	10388 mV
12.0 V B	10388 mV
Power 2	
0.9 V	902 mV
0.9 V PFE0	921 mV
0.9 V PFE1	907 mV
1.0 V PFE0	996 mV
1.0 V PFE1	974 mV
1.1 V	1095 mV
1.5 V_0	1495 mV
1.5 V_1	1478 mV
Power 3	
1.0 V PFE0	997 mV
1.0 V PFE1	998 mV
1.0 V PFE0 *	993 mV
1.0 V PFE1 *	991 mV
1.8 V PFE 0	1796 mV
1.8 V PFE 1	1789 mV
2.5 V	2465 mV
12.0 V	11609 mV
Power 4	
1.0 V PFE0 LU0	1003 mV
1.0 V PFE1 LU0	1006 mV
1.0 V PFE1 LU2	1002 mV
1.0 V PFE0 LU0 *	1000 mV
1.0 V PFE1 LU0 *	998 mV
1.0 V PFE1 LU2 *	998 mV
12.0 V	11638 mV
12.0 V C	11702 mV
Power (Base/PMB/MMB)	
LMB0 VDD2V5	2484 mV
LMB0 VDD1V8	1780 mV
LMB0 VDD1V5	1496 mV
LMB0 PFE0 LU0 AVDD1V0	998 mV
LMB0 PFE0 LU0 VDD1V0	1004 mV
LMB0 VDD12V0	10528 mV

LMB1 VDD2V5	2472 mV
LMB1 VDD1V8	1776 mV
LMB1 VDD1V5	1474 mV
LMB1 PFE0 LU2 AVDD1V0	994 mV
LMB1 PFE0 LU2 VDD1V0	1004 mV
LMB1 VDD12V0	10544 mV
LMB2 VDD2V5	2476 mV
LMB2 VDD1V8	1790 mV
LMB2 VDD1V5	1492 mV
LMB2 PFE1 LU1 AVDD1V0	996 mV
LMB2 PFE1 LU1 VDD1V0	1010 mV
LMB2 VDD12V0	10528 mV
PMB 1.05v	1050 mV
PMB 1.5v	1499 mV
PMB 2.5v	2500 mV
PMB 3.3v	3300 mV
Bus Revision	80

show chassis environment fpc lcc (TX Matrix Router)

```

user@host> show chassis environment fpc lcc
0
lcc0-re0:
-----
FPC 1 status:
State                Online
Temperature Top      30 degrees C / 86 degrees F
Temperature Bottom   25 degrees C / 77 degrees F
Temperature MMB0     Absent
Temperature MMB1     27 degrees C / 80 degrees F
Power:
  1.8 V                1813 mV
  2.5 V                2504 mV
  3.3 V                3338 mV
  5.0 V                5037 mV
  1.8 V bias          1797 mV
  3.3 V bias          3301 mV
  5.0 V bias          5013 mV
  8.0 V bias          7345 mV
BUS Revision          40
FPC 2 status:

```



```

State                Online
Temperature Top      37 degrees C / 98 degrees F
Temperature Bottom   26 degrees C / 78 degrees F
Temperature MMB0     32 degrees C / 89 degrees F
Temperature MMB1     27 degrees C / 80 degrees F
Power:
  1.8 V              1791 mV
  2.5 V              2517 mV
  3.3 V              3308 mV
  5.0 V              5052 mV
  1.8 V bias         1797 mV
  3.3 V bias         3289 mV
  5.0 V bias         4991 mV
  8.0 V bias         7477 mV
BUS Revision         40

```

show chassis environment fpc lcc (TX Matrix Plus Router)

```

user@host> show chassis environment fpc lcc
0
lcc0-re0:
-----
FPC 1 status:
State                Online
Temperature Top      46 degrees C / 114 degrees F
Temperature Bottom   47 degrees C / 116 degrees F
Power
  1.8 V              1788 mV
  1.8 V bias         1787 mV
  3.3 V              3321 mV
  3.3 V bias         3306 mV
  5.0 V bias         5018 mV
  5.0 V TOP          5037 mV
  8.0 V bias         7223 mV
Power (Base/PMB/MMB)
  1.2 V              1205 mV
  1.5 V              1503 mV
  5.0 V BOT          5084 mV
  12.0 V TOP Base    11775 mV
  12.0 V BOT Base    11794 mV
  1.1 V PMB          1108 mV

```

1.2 V PMB	1196 mV
1.5 V PMB	1499 mV
1.8 V PMB	1811 mV
2.5 V PMB	2515 mV
3.3 V PMB	3318 mV
5.0 V PMB	5030 mV
12.0 V PMB	11832 mV
0.75 MMB TOP	752 mV
1.5 V MMB TOP	1489 mV
1.8 V MMB TOP	1782 mV
2.5 V MMB TOP	2498 mV
1.2 V MMB TOP	1155 mV
5.0 V MMB TOP	4902 mV
12.0 V MMB TOP	11721 mV
3.3 V MMB TOP	3316 mV
0.75 MMB BOT	754 mV
1.5 V MMB BOT	1482 mV
1.8 V MMB BOT	1758 mV
2.5 V MMB BOT	2488 mV
1.2 V MMB BOT	1157 mV
5.0 V MMB BOT	4962 mV
12.0 V MMB BOT	11691 mV
3.3 V MMB BOT	3308 mV
APS 00	1484 mV
APS 01	2503 mV
APS 02	3313 mV
5.0 V PIC 0	5025 mV
APS 10	1501 mV
APS 11	2466 mV
APS 12	3311 mV
5.0 V PIC 1	5081 mV
Bus Revision	49

show chassis environment fpc (QFX Series and OCX Series)

```

user@switch> show chassis environment fpc 0
FPC 0 status:
  State           Online
  Temperature     42 degrees C / 107 degrees F

```

show chassis environment fpc interconnect-device (QFabric Systems)

```

user@switch> show chassis environment fpc interconnect-device
interconnect1 0
FC 0 FPC 0 status:
  State                Online
  Left Intake Temperature  24 degrees C / 75 degrees F
  Right Intake Temperature 24 degrees C / 75 degrees F
  Left Exhaust Temperature 27 degrees C / 80 degrees F
  Right Exhaust Temperature 27 degrees C / 80 degrees F
  Power
    BIAS 3V3                3330 mV
    VDD 3V3                  3300 mV
    VDD 2V5                  2502 mV
    VDD 1V5                  1496 mV
    VDD 1V2                  1194 mV
    VDD 1V0                  1000 mV
    SW0 VDD 1V0              1020 mV
    SW0 CVDD 1V025           1032 mV
    SW1 VDD 1V0              1022 mV
    SW1 CVDD 1V025           1030 mV
    VDD 12V0 DIV3_33         3414 mV

```

show chassis environment fpc 5(PTX3000 Packet Transport Router)

```

user@host> show chassis environment fpc 5
FPC 5 status:
  State                Online
  Intake Temperature   31 degrees C / 87 degrees F
  Exhaust Temperature  41 degrees C / 105 degrees F
  Power
    FPC 12.0v           12221 mV
    FPC VCC 0.5-1.3v    1640 mV
    FPC VNN 0.5-1.3v    1640 mV
    FPC 1.0v            1640 mV
    FPC 1.1v            1640 mV
    FPC 1.35v           1640 mV
    FPC VDDQ 1.5v       1640 mV
    FPC 1.8v            1640 mV
    FPC 3.3v            3280 mV

```

FPC 5.0v bias	5143 mV
FPC 5.0v usb	5143 mV
FPC VCC 12.0v	12289 mV
FPC Vref 3.3v	3280 mV
MAIN 12.0v-i	2265 mA

show chassis environment fpc 0 (PTX5000 Packet Transport Router)

```

user@host> show chassis environment fpc 0
FPC 0 status:
  State                Online
  PMB Temperature      35 degrees C / 95 degrees F
  Intake Temperature   33 degrees C / 91 degrees F
  Exhaust A Temperature 51 degrees C / 123 degrees F
  Exhaust B Temperature 43 degrees C / 109 degrees F
  TL0 Temperature      48 degrees C / 118 degrees F
  TQ0 Temperature      53 degrees C / 127 degrees F
  TL1 Temperature      56 degrees C / 132 degrees F
  TQ1 Temperature      58 degrees C / 136 degrees F
  TL2 Temperature      55 degrees C / 131 degrees F
  TQ2 Temperature      57 degrees C / 134 degrees F
  TL3 Temperature      59 degrees C / 138 degrees F
  TQ3 Temperature      59 degrees C / 138 degrees F
Power
  PMB  1.05v          1049 mV
  PMB  1.5v           1500 mV
  PMB  2.5v           2500 mV
  PMB  3.3v           3299 mV
  PFE0 1.5v           1500 mV
  PFE0 1.0v           999 mV
  TQ0  0.9v           900 mV
  TL0  0.9v           900 mV
  PFE1 1.5v           1499 mV
  PFE1 1.0v           999 mV
  TQ1  0.9v           899 mV
  TL1  0.9v           900 mV
  PFE2 1.5v           1500 mV
  PFE2 1.0v           1000 mV
  TQ2  0.9v           900 mV
  TL2  0.9v           900 mV
  PFE3 1.5v           1499 mV

```

PFE3	1.0v	1000 mV
TQ3	0.9v	900 mV
TL3	0.9v	900 mV
Bias	3.3v	3327 mV
FPC	3.3v	3300 mV
FPC	2.5v	2500 mV
SAM	0.9v	900 mV
A	12.0v	2014 mV
B	12.0v	2030 mV

show chassis environment fpc 07 (PTX5000 Packet Transport Router with FPC2-PTX-P1A)

```

user@host> show chassis environment fpc 07
FPC 7 status:
State                               Online
PMB TEMP0 Temperature               32 degrees C / 89 degrees F
PMB TEMP1 Temperature               28 degrees C / 82 degrees F
PMB CPU Temperature                  46 degrees C / 114 degrees F
Intake Temperature                   35 degrees C / 95 degrees F
Exhaust A Temperature                55 degrees C / 131 degrees F
Exhaust B Temperature                54 degrees C / 129 degrees F
TL5 Temperature                      59 degrees C / 138 degrees F
TQ5 Temperature                      57 degrees C / 134 degrees F
TL6 Temperature                      57 degrees C / 134 degrees F
TQ6 Temperature                      51 degrees C / 123 degrees F
TL1 Temperature                      76 degrees C / 168 degrees F
TQ1 Temperature                      58 degrees C / 136 degrees F
TL2 Temperature                      75 degrees C / 167 degrees F
TQ2 Temperature                      57 degrees C / 134 degrees F
TL4 Temperature                      52 degrees C / 125 degrees F
TQ4 Temperature                      66 degrees C / 150 degrees F
TL7 Temperature                      52 degrees C / 125 degrees F
TQ7 Temperature                      60 degrees C / 140 degrees F
TL0 Temperature                      72 degrees C / 161 degrees F
TQ0 Temperature                      73 degrees C / 163 degrees F
TL3 Temperature                      64 degrees C / 147 degrees F
TQ3 Temperature                      70 degrees C / 158 degrees F
Power
PMB 1.05v                            1049 mV
PMB 3.3v                              3299 mV
PMB 1.1v-a                            1100 mV

```

PMB	1.5v	1499 mV
PMB	1.1v-b	1100 mV
Base	3.3v	3300 mV
FPC Base	2.5v	2499 mV
TL1	0.9v	897 mV
TQ1	0.9v	897 mV
PFE1	1.0v	999 mV
PFE1	1.5v	1499 mV
TL2	0.9v	897 mV
TQ2	0.9v	897 mV
PFE2	1.0v	999 mV
PFE2	1.5v	1499 mV
FPC Base	1.0v	1000 mV
FPC Base	1.2v	1199 mV
TL5	0.9v	898 mV
TQ5	0.9v	898 mV
PFE5	1.0v	1000 mV
PFE5	1.5v	1500 mV
TL6	0.9v	897 mV
TQ6	0.9v	897 mV
PFE6	1.0v	1000 mV
PFE6	1.5v	1499 mV
Mezz Base	2.5v	2500 mV
TL0	0.9v	896 mV
TQ0	0.9v	896 mV
PFE0	1.0v	999 mV
PFE0	1.5v	1499 mV

show chassis environment fpc (PTX10008 router)

```

user@host> show chassis environment fpc
FPC 0 status:
  State                Online
FPC 0 Intake-A Temp Sensor 37 degrees C / 98 degrees F
FPC 0 Intake-B Temp Sensor 34 degrees C / 93 degrees F
FPC 0 Exhaust-A Temp Sensor37 degrees C / 98 degrees F
FPC 0 Exhaust-B Temp Sensor38 degrees C / 100 degrees F
FPC 0 Exhaust-C Temp Sensor40 degrees C / 104 degrees F
FPC 0 PE0 Temp Sensor      41 degrees C / 105 degrees F
FPC 0 PE1 Temp Sensor      42 degrees C / 107 degrees F
FPC 0 PE2 Temp Sensor      44 degrees C / 111 degrees F

```

FPC 0 LCPU Temp Sensor 40 degrees C / 104 degrees F

Power

PE0 Core 0.9V	872 mV	28777 mA	25146 mW
PE0 HMC0 Core 0.9V	899 mV	10359 mA	9328 mW
PE1 Core 0.9V	896 mV	29476 mA	26414 mW
PE1 HMC0 Core 0.9V	899 mV	10218 mA	9187 mW
PE2 Core 0.9V	872 mV	28839 mA	25199 mW
PE2 HMC0 Core 0.9V	900 mV	10296 mA	9265 mW
PE0 Serdes 1.0V	1020 mV	29000 mA	29593 mW
PE1 Serdes 1.0V	1019 mV	29109 mA	29718 mW
PE2 Serdes 1.0V	1019 mV	28484 mA	29078 mW
LCPU Platform 1.1V	1099 mV	3515 mA	3867 mW
LCPU Core 1.0V	1000 mV	8750 mA	8703 mW
PHY VDD B 1.0V	1000 mV	17062 mA	17031 mW
PHY VDD A 1.0V	999 mV	15640 mA	15625 mW
BCM Core 1.0V	999 mV	7054 mA	7054 mW
BCM PEX 1.0V	999 mV	3562 mA	3558 mW
HMC Core 1.2V	1199 mV	1280 mA	1513 mW
HMC Serdes 1.2V	1199 mV	32937 mA	39500 mW
VDD 1.5V	1500 mV	2824 mA	4234 mW
VDD 2.5V	2449 mV	3812 mA	9343 mW
VDD 3.3V	3299 mV	5085 mA	16796 mW
12V	12259 mV	29609 mA	368196 mW

FPC 1 status:

State Online

FPC 1 Intake-A Temp Sensor 37 degrees C / 98 degrees F

FPC 1 Intake-B Temp Sensor 34 degrees C / 93 degrees F

FPC 1 Exhaust-A Temp Sensor 38 degrees C / 100 degrees F

FPC 1 Exhaust-B Temp Sensor 38 degrees C / 100 degrees F

FPC 1 Exhaust-C Temp Sensor 40 degrees C / 104 degrees F

FPC 1 PE0 Temp Sensor 41 degrees C / 105 degrees F

FPC 1 PE1 Temp Sensor 42 degrees C / 107 degrees F

FPC 1 PE2 Temp Sensor 44 degrees C / 111 degrees F

FPC 1 LCPU Temp Sensor 39 degrees C / 102 degrees F

Power

PE0 Core 0.9V	898 mV	29351 mA	26421 mW
PE0 HMC0 Core 0.9V	899 mV	9734 mA	8750 mW
PE1 Core 0.9V	873 mV	28539 mA	24933 mW
PE1 HMC0 Core 0.9V	899 mV	9937 mA	8937 mW
PE2 Core 0.9V	875 mV	28906 mA	25316 mW
PE2 HMC0 Core 0.9V	899 mV	10140 mA	9125 mW
PE0 Serdes 1.0V	1019 mV	28312 mA	28890 mW
PE1 Serdes 1.0V	1020 mV	28656 mA	29234 mW

PE2 Serdes 1.0V	1020 mV	29437 mA	30015 mW
LCPU Platform 1.1V	1100 mV	4617 mA	5078 mW
LCPU Core 1.0V	1000 mV	8781 mA	8781 mW
PHY VDD B 1.0V	1000 mV	15953 mA	15984 mW
PHY VDD A 1.0V	1000 mV	15484 mA	15484 mW
BCM Core 1.0V	999 mV	7945 mA	7937 mW
BCM PEX 1.0V	999 mV	3515 mA	3515 mW
HMC Core 1.2V	1199 mV	1269 mA	1521 mW
HMC Serdes 1.2V	1199 mV	33000 mA	39593 mW
VDD 1.5V	1500 mV	2691 mA	4062 mW
VDD 2.5V	2449 mV	3582 mA	8781 mW
VDD 3.3V	3300 mV	2563 mA	8458 mW
12V	12311 mV	29002 mA	357577 mW

FPC 2 status:

State	Online
FPC 2 Intake-A Temp Sensor	43 degrees C / 109 degrees F
FPC 2 Intake-B Temp Sensor	30 degrees C / 86 degrees F
FPC 2 Exhaust-A Temp Sensor	50 degrees C / 122 degrees F
FPC 2 Exhaust-B Temp Sensor	52 degrees C / 125 degrees F
FPC 2 Exhaust-C Temp Sensor	51 degrees C / 123 degrees F
FPC 2 PE0 Temp Sensor	48 degrees C / 118 degrees F
FPC 2 PE1 Temp Sensor	56 degrees C / 132 degrees F
FPC 2 PE2 Temp Sensor	48 degrees C / 118 degrees F
FPC 2 PE3 Temp Sensor	57 degrees C / 134 degrees F
FPC 2 PE4 Temp Sensor	48 degrees C / 118 degrees F
FPC 2 PE5 Temp Sensor	60 degrees C / 140 degrees F
FPC 2 LCPU Temp Sensor	47 degrees C / 116 degrees F

Power

PE0 Core 0.9V	874 mV	28117 mA	24617 mW
PE1 Core 0.9V	899 mV	29601 mA	26632 mW
PE0 Serdes 1.0V	1019 mV	41031 mA	41843 mW
PE1 Serdes 1.0V	1019 mV	35656 mA	36343 mW
PE0 HMC Core 0.9V	899 mV	8125 mA	7312 mW
PE0,1 HMC Memory 1.2V	1199 mV	565 mA	688 mW
PE1 HMC Core 0.9V	899 mV	7921 mA	7125 mW
PE0,1 HMC Serdes 1.2V	1199 mV	21281 mA	25562 mW
PE2 Core 0.9V	899 mV	29187 mA	26242 mW
PE3 Core 0.9V	899 mV	29976 mA	27074 mW
PE2 Serdes 1.0V	1019 mV	38562 mA	39343 mW
PE3 Serdes 1.0V	1019 mV	34937 mA	35656 mW
PE2 HMC Core 0.9V	899 mV	8093 mA	7281 mW
PE2,3 HMC Memory 1.2V	1199 mV	610 mA	732 mW
PE3 HMC Core 0.9V	899 mV	7710 mA	6937 mW

PE2,3 HMC Serdes 1.2V	1199 mV	21500 mA	25812 mW
VDD 3.3V	3300 mV	7937 mA	26187 mW
VDD 1.5V	1499 mV	3234 mA	4851 mW
VDD 2.5V	2449 mV	4539 mA	11109 mW
PE4 Core 0.9V	874 mV	29914 mA	26183 mW
PE5 Core 0.9V	874 mV	29820 mA	26031 mW
PE4 Serdes 1.0V	1020 mV	43968 mA	44843 mW
PE5 Serdes 1.0V	1019 mV	27453 mA	28031 mW
PE4 HMC Core 0.9V	900 mV	7937 mA	7140 mW
PE4,5 HMC Memory 1.2V	1200 mV	1185 mA	1421 mW
PE5 HMC Core 0.9V	899 mV	8718 mA	7843 mW
PE4,5 HMC Serdes 1.2V	1199 mV	21125 mA	25343 mW
LCPU platform 1.1V	1099 mV	3777 mA	4156 mW
LCPU core 1.0V	1000 mV	9062 mA	9062 mW
BCM core 1.0V	1000 mV	9328 mA	9328 mW
BCM & PEX Serdes 1.0V	999 mV	4125 mA	4125 mW
12V	12311 mV	53347 mA	660345 mW

FPC 3 status:

State	Online
FPC 3 Intake-A Temp Sensor	43 degrees C / 109 degrees F
FPC 3 Intake-B Temp Sensor	30 degrees C / 86 degrees F
FPC 3 Exhaust-A Temp Sensor	48 degrees C / 118 degrees F
FPC 3 Exhaust-B Temp Sensor	49 degrees C / 120 degrees F
FPC 3 Exhaust-C Temp Sensor	47 degrees C / 116 degrees F
FPC 3 PE0 Temp Sensor	48 degrees C / 118 degrees F
FPC 3 PE1 Temp Sensor	55 degrees C / 131 degrees F
FPC 3 PE2 Temp Sensor	47 degrees C / 116 degrees F
FPC 3 PE3 Temp Sensor	54 degrees C / 129 degrees F
FPC 3 PE4 Temp Sensor	48 degrees C / 118 degrees F
FPC 3 PE5 Temp Sensor	58 degrees C / 136 degrees F
FPC 3 LCPU Temp Sensor	46 degrees C / 114 degrees F

Power

PE0 Core 0.9V	899 mV	29695 mA	26718 mW
PE1 Core 0.9V	899 mV	29695 mA	26710 mW
PE0 Serdes 1.0V	1020 mV	40156 mA	40906 mW
PE1 Serdes 1.0V	1020 mV	35281 mA	35968 mW
PE0 HMC Core 0.9V	900 mV	7492 mA	6742 mW
PE0,1 HMC Memory 1.2V	1199 mV	569 mA	683 mW
PE1 HMC Core 0.9V	899 mV	7570 mA	6812 mW
PE0,1 HMC Serdes 1.2V	1199 mV	20562 mA	24656 mW
PE2 Core 0.9V	899 mV	29734 mA	26765 mW
PE3 Core 0.9V	900 mV	29960 mA	26968 mW
PE2 Serdes 1.0V	1019 mV	37718 mA	38500 mW

PE3 Serdes 1.0V	1020 mV	35250 mA	35937 mW
PE2 HMC Core 0.9V	899 mV	7750 mA	6976 mW
PE2,3 HMC Memory 1.2V	1200 mV	546 mA	656 mW
PE3 HMC Core 0.9V	899 mV	7718 mA	6945 mW
PE2,3 HMC Serdes 1.2V	1199 mV	20625 mA	24750 mW
VDD 3.3V	3299 mV	5917 mA	19515 mW
VDD 1.5V	1499 mV	4015 mA	6015 mW
VDD 2.5V	2449 mV	4335 mA	10625 mW
PE4 Core 0.9V	899 mV	29835 mA	26875 mW
PE5 Core 0.9V	924 mV	30554 mA	28277 mW
PE4 Serdes 1.0V	1019 mV	43281 mA	44187 mW
PE5 Serdes 1.0V	1020 mV	27140 mA	27703 mW
PE4 HMC Core 0.9V	899 mV	7476 mA	6726 mW
PE4,5 HMC Memory 1.2V	1199 mV	531 mA	637 mW
PE5 HMC Core 0.9V	899 mV	7539 mA	6781 mW
PE4,5 HMC Serdes 1.2V	1199 mV	20375 mA	24468 mW
LCPU platform 1.1V	1099 mV	3453 mA	3796 mW
LCPU core 1.0V	999 mV	8984 mA	8984 mW
BCM core 1.0V	999 mV	7929 mA	7921 mW
BCM & PEX Serdes 1.0V	1000 mV	4046 mA	4046 mW
12V	12351 mV	51918 mA	644880 mW

FPC 5 status:

```

State                               Online
FPC 5 Intake-A Temp Sensor Failed
FPC 5 Intake-B Temp Sensor Failed
FPC 5 Exhaust-A Temp Sensor41 degrees C / 105 degrees F
FPC 5 Exhaust-B Temp Sensor41 degrees C / 105 degrees F
FPC 5 Exhaust-C Temp Sensor42 degrees C / 107 degrees F
FPC 5 PE0 Temp Sensor      47 degrees C / 116 degrees F
FPC 5 PE1 Temp Sensor      49 degrees C / 120 degrees F
FPC 5 PE2 Temp Sensor      53 degrees C / 127 degrees F
FPC 5 LCPU Temp Sensor     Failed

```

Power

PE0 Core 0.9V	923 mV	30976 mA	28578 mW
PE0 HMC0 Core 0.9V	899 mV	10093 mA	9078 mW
PE1 Core 0.9V	897 mV	29398 mA	26414 mW
PE1 HMC0 Core 0.9V	899 mV	9734 mA	8750 mW
PE2 Core 0.9V	922 mV	30226 mA	27886 mW
PE2 HMC0 Core 0.9V	899 mV	9984 mA	8968 mW
PE0 Serdes 1.0V	1019 mV	29296 mA	29890 mW
PE1 Serdes 1.0V	1020 mV	28687 mA	29296 mW
PE2 Serdes 1.0V	1020 mV	28187 mA	28765 mW
LCPU Platform 1.1V	1100 mV	3664 mA	4031 mW

LCPU Core 1.0V	999 mV	9125 mA	9125 mW
PHY VDD B 1.0V	999 mV	15593 mA	15593 mW
PHY VDD A 1.0V	1000 mV	15453 mA	15453 mW
BCM Core 1.0V	999 mV	7773 mA	7765 mW
BCM PEX 1.0V	1000 mV	3460 mA	3464 mW
HMC Core 1.2V	1199 mV	1328 mA	1628 mW
HMC Serdes 1.2V	1199 mV	32203 mA	38625 mW
VDD 1.5V	1499 mV	2675 mA	4007 mW
VDD 2.5V	2450 mV	3675 mA	9000 mW
VDD 3.3V	3300 mV	1814 mA	5980 mW
12V	12272 mV	29045 mA	361369 mW

FPC 6 status:

State Online

FPC 6 Intake-A Temp Sensor 41 degrees C / 105 degrees F

FPC 6 Intake-B Temp Sensor 37 degrees C / 98 degrees F

FPC 6 Exhaust-A Temp Sensor 40 degrees C / 104 degrees F

FPC 6 Exhaust-B Temp Sensor 40 degrees C / 104 degrees F

FPC 6 Exhaust-C Temp Sensor 40 degrees C / 104 degrees F

FPC 6 PE0 Temp Sensor 45 degrees C / 113 degrees F

FPC 6 PE1 Temp Sensor 47 degrees C / 116 degrees F

FPC 6 PE2 Temp Sensor 51 degrees C / 123 degrees F

FPC 6 LCPU Temp Sensor 41 degrees C / 105 degrees F

Power

PE0 Core 0.9V	897 mV	30214 mA	27179 mW
PE0 HMC0 Core 0.9V	899 mV	10000 mA	8984 mW
PE1 Core 0.9V	873 mV	29332 mA	25601 mW
PE1 HMC0 Core 0.9V	899 mV	9828 mA	8828 mW
PE2 Core 0.9V	898 mV	30781 mA	27675 mW
PE2 HMC0 Core 0.9V	899 mV	10328 mA	9296 mW
PE0 Serdes 1.0V	1019 mV	28921 mA	29531 mW
PE1 Serdes 1.0V	1020 mV	29437 mA	30046 mW
PE2 Serdes 1.0V	1019 mV	29671 mA	30281 mW
LCPU Platform 1.1V	1100 mV	3671 mA	4039 mW
LCPU Core 1.0V	1000 mV	8218 mA	8187 mW
PHY VDD B 1.0V	1000 mV	15984 mA	15984 mW
PHY VDD A 1.0V	999 mV	16093 mA	16093 mW
BCM Core 1.0V	1000 mV	8046 mA	8062 mW
BCM PEX 1.0V	1000 mV	3500 mA	3500 mW
HMC Core 1.2V	1199 mV	1327 mA	1579 mW
HMC Serdes 1.2V	1199 mV	33031 mA	39593 mW
VDD 1.5V	1499 mV	2722 mA	4078 mW
VDD 2.5V	2449 mV	3539 mA	8671 mW

VDD 3.3V	3299 mV	8082 mA	26656 mW
12V	12311 mV	31124 mA	385270 mW

show chassis environment fpc (PTX10016 router)

```
user@host> show chassis environment fpc
```

```
FPC 1 status:
```

```
State                Online
FPC 1 Intake-A Temp Sensor 36 degrees C / 96 degrees F
FPC 1 Intake-B Temp Sensor 32 degrees C / 89 degrees F
FPC 1 Exhaust-A Temp Sensor37 degrees C / 98 degrees F
FPC 1 Exhaust-B Temp Sensor36 degrees C / 96 degrees F
FPC 1 Exhaust-C Temp Sensor36 degrees C / 96 degrees F
FPC 1 PE0 Temp Sensor      45 degrees C / 113 degrees F
FPC 1 PE1 Temp Sensor      46 degrees C / 114 degrees F
FPC 1 PE2 Temp Sensor      53 degrees C / 127 degrees F
FPC 1 LCPU Temp Sensor     35 degrees C / 95 degrees F
```

```
Power
```

PE0 Core 0.9V	897 mV	28992 mA	26027 mW
PE0 HMC0 Core 0.9V	899 mV	10156 mA	9156 mW
PE1 Core 0.9V	871 mV	28800 mA	25164 mW
PE1 HMC0 Core 0.9V	899 mV	10125 mA	9109 mW
PE2 Core 0.9V	898 mV	29914 mA	26906 mW
PE2 HMC0 Core 0.9V	899 mV	10343 mA	9296 mW
PE0 Serdes 1.0V	1019 mV	27515 mA	28093 mW
PE1 Serdes 1.0V	1020 mV	27968 mA	28546 mW
PE2 Serdes 1.0V	1019 mV	27796 mA	28359 mW
LCPU Platform 1.1V	1100 mV	3347 mA	3289 mW
LCPU Core 1.0V	1000 mV	7960 mA	7960 mW
PHY VDD B 1.0V	1000 mV	16437 mA	16437 mW
PHY VDD A 1.0V	999 mV	15656 mA	15656 mW
BCM Core 1.0V	1000 mV	7289 mA	7335 mW
BCM PEX 1.0V	999 mV	3453 mA	3453 mW
HMC Core 1.2V	1199 mV	1218 mA	1453 mW
HMC Serdes 1.2V	1199 mV	32093 mA	38562 mW
VDD 1.5V	1500 mV	2859 mA	4289 mW
VDD 2.5V	2449 mV	3875 mA	9500 mW
VDD 3.3V	3299 mV	2806 mA	9257 mW
12V	12351 mV	28569 mA	354877 mW

```
FPC 3 status:
```

```
State                Online
```

FPC 3 Intake-A Temp Sensor 35 degrees C / 95 degrees F
 FPC 3 Intake-B Temp Sensor 31 degrees C / 87 degrees F
 FPC 3 Exhaust-A Temp Sensor 36 degrees C / 96 degrees F
 FPC 3 Exhaust-B Temp Sensor 34 degrees C / 93 degrees F
 FPC 3 Exhaust-C Temp Sensor 33 degrees C / 91 degrees F
 FPC 3 PE0 Temp Sensor 43 degrees C / 109 degrees F
 FPC 3 PE1 Temp Sensor 45 degrees C / 113 degrees F
 FPC 3 PE2 Temp Sensor 49 degrees C / 120 degrees F
 FPC 3 LCPU Temp Sensor 35 degrees C / 95 degrees F

Power

PE0 Core 0.9V	897 mV	28832 mA	25871 mW
PE0 HMC0 Core 0.9V	899 mV	10359 mA	9328 mW
PE1 Core 0.9V	873 mV	28230 mA	24671 mW
PE1 HMC0 Core 0.9V	899 mV	10468 mA	9421 mW
PE2 Core 0.9V	898 mV	29539 mA	26539 mW
PE2 HMC0 Core 0.9V	899 mV	10656 mA	9593 mW
PE0 Serdes 1.0V	1020 mV	27484 mA	28031 mW
PE1 Serdes 1.0V	1019 mV	27515 mA	28078 mW
PE2 Serdes 1.0V	1020 mV	27625 mA	28187 mW
LCPU Platform 1.1V	1099 mV	3050 mA	3355 mW
LCPU Core 1.0V	999 mV	7820 mA	7804 mW
PHY VDD B 1.0V	999 mV	15406 mA	15406 mW
PHY VDD A 1.0V	1000 mV	14953 mA	14953 mW
BCM Core 1.0V	1000 mV	7648 mA	7648 mW
BCM PEX 1.0V	1000 mV	3531 mA	3531 mW
HMC Core 1.2V	1200 mV	1234 mA	1476 mW
HMC Serdes 1.2V	1199 mV	34671 mA	41593 mW
VDD 1.5V	1499 mV	3484 mA	5226 mW
VDD 2.5V	2449 mV	3218 mA	7890 mW
VDD 3.3V	3299 mV	2468 mA	8148 mW
12V	12311 mV	28785 mA	355950 mW

FPC 6 status:

State Online
 FPC 6 Intake-A Temp Sensor 34 degrees C / 93 degrees F
 FPC 6 Intake-B Temp Sensor 31 degrees C / 87 degrees F
 FPC 6 Exhaust-A Temp Sensor 34 degrees C / 93 degrees F
 FPC 6 Exhaust-B Temp Sensor 35 degrees C / 95 degrees F
 FPC 6 Exhaust-C Temp Sensor 35 degrees C / 95 degrees F
 FPC 6 PE0 Temp Sensor 42 degrees C / 107 degrees F
 FPC 6 PE1 Temp Sensor 43 degrees C / 109 degrees F
 FPC 6 PE2 Temp Sensor 47 degrees C / 116 degrees F
 FPC 6 LCPU Temp Sensor 34 degrees C / 93 degrees F

Power

PE0 Core 0.9V	922 mV	29394 mA	27160 mW
PE0 HMC0 Core 0.9V	899 mV	10078 mA	9062 mW
PE1 Core 0.9V	923 mV	29636 mA	27304 mW
PE1 HMC0 Core 0.9V	899 mV	9890 mA	8890 mW
PE2 Core 0.9V	898 mV	29734 mA	26757 mW
PE2 HMC0 Core 0.9V	899 mV	9968 mA	8968 mW
PE0 Serdes 1.0V	1020 mV	26968 mA	27515 mW
PE1 Serdes 1.0V	1019 mV	27421 mA	27984 mW
PE2 Serdes 1.0V	1019 mV	27625 mA	28171 mW
LCPU Platform 1.1V	1099 mV	3230 mA	4742 mW
LCPU Core 1.0V	999 mV	8171 mA	8171 mW
PHY VDD B 1.0V	1000 mV	15671 mA	15687 mW
PHY VDD A 1.0V	999 mV	15703 mA	15703 mW
BCM Core 1.0V	999 mV	7500 mA	7492 mW
BCM PEX 1.0V	1000 mV	3480 mA	3468 mW
HMC Core 1.2V	1199 mV	1199 mA	1440 mW
HMC Serdes 1.2V	1199 mV	31046 mA	37250 mW
VDD 1.5V	1499 mV	2804 mA	4203 mW
VDD 2.5V	2449 mV	3746 mA	9171 mW
VDD 3.3V	3300 mV	3173 mA	10476 mW
12V	12311 mV	28786 mA	355654 mW

FPC 8 status:

State	Online
FPC 8 Intake-A Temp Sensor	34 degrees C / 93 degrees F
FPC 8 Intake-B Temp Sensor	30 degrees C / 86 degrees F
FPC 8 Exhaust-A Temp Sensor	37 degrees C / 98 degrees F
FPC 8 Exhaust-B Temp Sensor	37 degrees C / 98 degrees F
FPC 8 Exhaust-C Temp Sensor	37 degrees C / 98 degrees F
FPC 8 PE0 Temp Sensor	42 degrees C / 107 degrees F
FPC 8 PE1 Temp Sensor	44 degrees C / 111 degrees F
FPC 8 PE2 Temp Sensor	47 degrees C / 116 degrees F
FPC 8 LCPU Temp Sensor	33 degrees C / 91 degrees F

Power

PE0 Core 0.9V	897 mV	29382 mA	26437 mW
PE0 HMC0 Core 0.9V	899 mV	10265 mA	9250 mW
PE1 Core 0.9V	872 mV	28867 mA	25175 mW
PE1 HMC0 Core 0.9V	899 mV	10171 mA	9109 mW
PE2 Core 0.9V	899 mV	30210 mA	27214 mW
PE2 HMC0 Core 0.9V	900 mV	10187 mA	9171 mW
PE0 Serdes 1.0V	1020 mV	27843 mA	28421 mW
PE1 Serdes 1.0V	1020 mV	28265 mA	28828 mW
PE2 Serdes 1.0V	1019 mV	28406 mA	29000 mW
LCPU Platform 1.1V	1099 mV	3000 mA	3300 mW

LCPU Core 1.0V	1000 mV	7937 mA	7937 mW
PHY VDD B 1.0V	1000 mV	15843 mA	15843 mW
PHY VDD A 1.0V	1000 mV	15250 mA	15250 mW
BCM Core 1.0V	999 mV	6914 mA	6898 mW
BCM PEX 1.0V	999 mV	3445 mA	3445 mW
HMC Core 1.2V	1199 mV	1162 mA	1390 mW
HMC Serdes 1.2V	1199 mV	33437 mA	40125 mW
VDD 1.5V	1499 mV	2851 mA	4273 mW
VDD 2.5V	2450 mV	3867 mA	9484 mW
VDD 3.3V	3300 mV	3258 mA	10753 mW
12V	12338 mV	28656 mA	356171 mW

FPC 9 status:

State	Online
FPC 9 Intake-A Temp Sensor	44 degrees C / 111 degrees F
FPC 9 Intake-B Temp Sensor	28 degrees C / 82 degrees F
FPC 9 Exhaust-A Temp Sensor	51 degrees C / 123 degrees F
FPC 9 Exhaust-B Temp Sensor	52 degrees C / 125 degrees F
FPC 9 Exhaust-C Temp Sensor	48 degrees C / 118 degrees F
FPC 9 PE0 Temp Sensor	52 degrees C / 125 degrees F
FPC 9 PE1 Temp Sensor	65 degrees C / 149 degrees F
FPC 9 PE2 Temp Sensor	50 degrees C / 122 degrees F
FPC 9 PE3 Temp Sensor	65 degrees C / 149 degrees F
FPC 9 PE4 Temp Sensor	50 degrees C / 122 degrees F
FPC 9 PE5 Temp Sensor	67 degrees C / 152 degrees F
FPC 9 LCPU Temp Sensor	45 degrees C / 113 degrees F

Power

PE0 Core 0.9V	875 mV	28316 mA	24808 mW
PE1 Core 0.9V	875 mV	28546 mA	24996 mW
PE0 Serdes 1.0V	1019 mV	38906 mA	39687 mW
PE1 Serdes 1.0V	1020 mV	33078 mA	33781 mW
PE0 HMC Core 0.9V	899 mV	7718 mA	6945 mW
PE0,1 HMC Memory 1.2V	1199 mV	579 mA	695 mW
PE1 HMC Core 0.9V	899 mV	7289 mA	6570 mW
PE0,1 HMC Serdes 1.2V	1199 mV	20187 mA	24250 mW
PE2 Core 0.9V	924 mV	29062 mA	26894 mW
PE3 Core 0.9V	900 mV	28914 mA	26039 mW
PE2 Serdes 1.0V	1020 mV	36375 mA	37093 mW
PE3 Serdes 1.0V	1019 mV	32640 mA	33296 mW
PE2 HMC Core 0.9V	900 mV	7695 mA	6921 mW
PE2,3 HMC Memory 1.2V	1199 mV	562 mA	674 mW
PE3 HMC Core 0.9V	899 mV	7554 mA	6796 mW
PE2,3 HMC Serdes 1.2V	1199 mV	20156 mA	24218 mW
VDD 3.3V	3300 mV	8964 mA	29609 mW

VDD 1.5V	1499 mV	3968 mA	5945 mW
VDD 2.5V	2449 mV	4414 mA	10890 mW
PE4 Core 0.9V	900 mV	28527 mA	25679 mW
PE5 Core 0.9V	899 mV	28902 mA	26035 mW
PE4 Serdes 1.0V	1019 mV	41281 mA	42125 mW
PE5 Serdes 1.0V	1019 mV	25781 mA	26328 mW
PE4 HMC Core 0.9V	900 mV	7382 mA	6648 mW
PE4,5 HMC Memory 1.2V	1199 mV	626 mA	750 mW
PE5 HMC Core 0.9V	899 mV	7562 mA	6796 mW
PE4,5 HMC Serdes 1.2V	1199 mV	20312 mA	24375 mW
LCPU platform 1.1V	1099 mV	3687 mA	4054 mW
LCPU core 1.0V	1000 mV	9000 mA	9000 mW
BCM core 1.0V	999 mV	7843 mA	7835 mW
BCM & PEX Serdes 1.0V	999 mV	4062 mA	4062 mW
12V	12417 mV	51659 mA	643215 mW

show chassis environment FPC 1 (MX Routers with Media Services Blade [MSB])

```

user@switch> show chassis environment fpc 1
FPC 1 status:
  State                Online
  Temperature Intake    36 degrees C / 96 degrees F
  Temperature Exhaust A 39 degrees C / 102 degrees F
  Temperature LU TSen   52 degrees C / 125 degrees F
  Temperature LU Chip   54 degrees C / 129 degrees F
  Temperature XM TSen   52 degrees C / 125 degrees F
  Temperature XM Chip   60 degrees C / 140 degrees F
  Temperature PCIe TSen 52 degrees C / 125 degrees F
  Temperature PCIe Chip 69 degrees C / 156 degrees F
Power
  MPC-BIAS3V3-z12106    3302 mV
  MPC-VDD3V3-z16100     3325 mV
  MPC-AVDD1V0-z16100    1007 mV
  MPC-PCIE_1V0-z16100    904 mV
  MPC-LU0_1V0-z12004     996 mV
  MPC-VDD_1V5-z12004    1498 mV
  MPC-12VA-BMR453       11733 mV
  MPC-12VB-BMR453       11728 mV
  MPC-XM_0V9-vt273m     900 mV

```

show chassis environment FPC (Junos OS Evolved)

```

user@switch> show chassis environment fpc
FPC 0 status:
  State                Online
  Intake Temperature   32 degrees C / 89 degrees F
  Exhaust-A Temperature 43 degrees C / 109 degrees F
  Exhaust-B Temperature 32 degrees C / 89 degrees F
  PE0 Temperature      34 degrees C / 93 degrees F
  PE1 Temperature      38 degrees C / 100 degrees F
  PE2 Temperature      38 degrees C / 100 degrees F
  PE3 Temperature      36 degrees C / 96 degrees F
  PE4 Temperature      35 degrees C / 95 degrees F
  PE5 Temperature      35 degrees C / 95 degrees F
  Power 1
    RT_1 1.0v          1018 mV
    RT_2 1.0v          1018 mV
  Power 2
    FPC 1 1.0v         999 mV
    FPC 2 1.0v         998 mV
  Power 3
    FPC 2.5v           2499 mV
    FPC 3.3v           3299 mV
  Power 4
    FPC 0.9v           899 mV
    FPC 1.5v           1499 mV
  Power 5
    PE0 1 1.0v         1039 mV
    PE0 2 1.0v         1039 mV
  Power 6
    PE0 1 0.9v         900 mV
    PE0 2 0.9v         900 mV
  Power 7
    PE0 3 0.9v         902 mV
    PE0 4 0.9v         902 mV
  Power 8
    PE0 H 0.9v         899 mV
    PE0 H 1.2v         1199 mV

```

Power 9		
PE1 1 1.0v		1040 mV
PE1 2 1.0v		1039 mV
Power 10		
PE1 1 0.9v		901 mV
PE1 2 0.9v		901 mV
Power 11		
PE1 3 0.9v		900 mV
PE1 4 0.9v		900 mV
Power 12		
PE1 H 0.9v		899 mV
PE1 H 1.2v		1199 mV
Power 13		
PE2 1 1.0v		1039 mV
PE2 2 1.0v		1039 mV
Power 14		
PE2 1 0.9v		900 mV
PE2 2 0.9v		900 mV
Power 15		
PE2 3 0.9v		900 mV
PE2 4 0.9v		900 mV
Power 16		
PE2 H 0.9v		899 mV
PE2 H 1.2v		1199 mV
Power 17		
PE3 1 1.0v		1039 mV
PE3 2 1.0v		1039 mV
Power 18		
PE3 1 0.9v		899 mV
PE3 2 0.9v		900 mV
Power 19		
PE3 3 0.9v		899 mV
PE3 4 0.9v		900 mV
Power 20		
PE3 H 0.9v		899 mV
PE3 H 1.2v		1199 mV
Power 21		
PE4 1 1.0v		1039 mV
PE4 2 1.0v		1039 mV
Power 22		
PE4 1 0.9v		900 mV
PE4 2 0.9v		900 mV
Power 23		

PE4 3 0.9v	901 mV
PE4 4 0.9v	901 mV
Power 24	
PE4 H 0.9v	899 mV
PE4 H 1.2v	1199 mV
Power 25	
PE5 1 1.0v	1040 mV
PE5 2 1.0v	1039 mV
Power 26	
PE5 1 0.9v	901 mV
PE5 2 0.9v	901 mV
Power 27	
PE5 3 0.9v	901 mV
PE5 4 0.9v	901 mV
Power 28	
PE5 H 0.9v	899 mV
PE5 H 1.2v	1199 mV
Power 29	
PIC0 12.0v	12342 mV
Power 30	
PIC1 12.0v	12342 mV
Power 31	
A 12.0v	12375 mV
B 12.0v	1008 mV
Bus Revision	115
FPC 1 status:	
State	Online
Intake Temperature	33 degrees C / 91 degrees F
Exhaust-A Temperature	44 degrees C / 111 degrees F
Exhaust-B Temperature	33 degrees C / 91 degrees F
PE0 Temperature	34 degrees C / 93 degrees F
PE1 Temperature	38 degrees C / 100 degrees F
PE2 Temperature	37 degrees C / 98 degrees F
PE3 Temperature	36 degrees C / 96 degrees F
PE4 Temperature	34 degrees C / 93 degrees F
PE5 Temperature	36 degrees C / 96 degrees F
Power 1	
RT_1 1.0v	1018 mV
RT_2 1.0v	1018 mV
Power 2	
FPC 1 1.0v	999 mV
FPC 2 1.0v	999 mV
Power 3	

FPC	2.5v	2499 mV
FPC	3.3v	3300 mV
Power 4		
FPC	0.9v	899 mV
FPC	1.5v	1500 mV
Power 5		
PE0 1	1.0v	1039 mV
PE0 2	1.0v	1039 mV
Power 6		
PE0 1	0.9v	925 mV
PE0 2	0.9v	925 mV
Power 7		
PE0 3	0.9v	925 mV
PE0 4	0.9v	926 mV
Power 8		
PE0 H	0.9v	899 mV
PE0 H	1.2v	1199 mV
Power 9		
PE1 1	1.0v	1040 mV
PE1 2	1.0v	1039 mV
Power 10		
PE1 1	0.9v	900 mV
PE1 2	0.9v	901 mV
Power 11		
PE1 3	0.9v	899 mV
PE1 4	0.9v	900 mV
Power 12		
PE1 H	0.9v	899 mV
PE1 H	1.2v	1199 mV
Power 13		
PE2 1	1.0v	1040 mV
PE2 2	1.0v	1039 mV
Power 14		
PE2 1	0.9v	926 mV
PE2 2	0.9v	926 mV
Power 15		
PE2 3	0.9v	927 mV
PE2 4	0.9v	927 mV
Power 16		
PE2 H	0.9v	899 mV
PE2 H	1.2v	1199 mV
Power 17		
PE3 1	1.0v	1039 mV

PE3 2 1.0v	1039 mV
Power 18	
PE3 1 0.9v	926 mV
PE3 2 0.9v	927 mV
Power 19	
PE3 3 0.9v	925 mV
PE3 4 0.9v	926 mV
Power 20	
PE3 H 0.9v	899 mV
PE3 H 1.2v	1199 mV
Power 21	
PE4 1 1.0v	1039 mV
PE4 2 1.0v	1040 mV
Power 22	
PE4 1 0.9v	925 mV
PE4 2 0.9v	925 mV
Power 23	
PE4 3 0.9v	925 mV
PE4 4 0.9v	926 mV
Power 24	
PE4 H 0.9v	900 mV
PE4 H 1.2v	1199 mV
Power 25	
PE5 1 1.0v	1039 mV
PE5 2 1.0v	1039 mV
Power 26	
PE5 1 0.9v	898 mV
PE5 2 0.9v	899 mV
Power 27	
PE5 3 0.9v	900 mV
PE5 4 0.9v	900 mV
Power 28	
PE5 H 0.9v	899 mV
PE5 H 1.2v	1199 mV
Power 29	
PIC0 12.0v	0 mV
Power 30	
PIC1 12.0v	12402 mV
Power 31	
A 12.0v	12344 mV
B 12.0v	1008 mV
Bus Revision	115

FPC 2 status:

State	Online
Intake Temperature	31 degrees C / 87 degrees F
Exhaust-A Temperature	38 degrees C / 100 degrees F
Exhaust-B Temperature	28 degrees C / 82 degrees F
PE0 Temperature	28 degrees C / 82 degrees F
PE1 Temperature	33 degrees C / 91 degrees F
PE2 Temperature	34 degrees C / 93 degrees F
PE3 Temperature	31 degrees C / 87 degrees F
Power 1	
RT_1 1.0v	1018 mV
RT_2 1.0v	1018 mV
Power 2	
FPC 1 1.0v	999 mV
FPC 2 1.0v	999 mV
Power 3	
FPC 2.5v	2499 mV
FPC 3.3v	3299 mV
Power 4	
FPC 0.9v	899 mV
FPC 1.5v	1500 mV
Power 5	
PE0 1 1.0v	1039 mV
PE0 2 1.0v	1040 mV
Power 6	
PE0 1 0.9v	900 mV
PE0 2 0.9v	901 mV
Power 7	
PE0 3 0.9v	900 mV
PE0 4 0.9v	900 mV
Power 8	
PE0 H 0.9v	899 mV
PE0 H 1.2v	1199 mV
Power 9	
PE1 1 1.0v	1039 mV
PE1 2 1.0v	1039 mV
Power 10	
PE1 1 0.9v	875 mV
PE1 2 0.9v	876 mV
Power 11	
PE1 3 0.9v	875 mV
PE1 4 0.9v	875 mV
Power 12	
PE1 H 0.9v	899 mV

PE1 H 1.2v	1199 mV
Power 13	
PE2 1 1.0v	1039 mV
PE2 2 1.0v	1039 mV
Power 14	
PE2 1 0.9v	900 mV
PE2 2 0.9v	900 mV
Power 15	
PE2 3 0.9v	900 mV
PE2 4 0.9v	900 mV
Power 16	
PE2 H 0.9v	899 mV
PE2 H 1.2v	1199 mV
Power 17	
PE3 1 1.0v	1039 mV
PE3 2 1.0v	1039 mV
Power 18	
PE3 1 0.9v	875 mV
PE3 2 0.9v	875 mV
Power 19	
PE3 3 0.9v	875 mV
PE3 4 0.9v	875 mV
Power 20	
PE3 H 0.9v	899 mV
PE3 H 1.2v	1200 mV
Power 21	
PIC0 12.0v	12281 mV
Power 22	
PIC1 12.0v	0 mV
Power 23	
A 12.0v	12406 mV
B 12.0v	1006 mV
Bus Revision	115
FPC 3 status:	
State	Online
Intake Temperature	33 degrees C / 91 degrees F
Exhaust-A Temperature	44 degrees C / 111 degrees F
Exhaust-B Temperature	30 degrees C / 86 degrees F
PE0 Temperature	33 degrees C / 91 degrees F
PE1 Temperature	37 degrees C / 98 degrees F
PE2 Temperature	38 degrees C / 100 degrees F
PE3 Temperature	34 degrees C / 93 degrees F
PE4 Temperature	33 degrees C / 91 degrees F

PE5 Temperature 36 degrees C / 96 degrees F

Power 1

RT_1 1.0v 1018 mV

RT_2 1.0v 1018 mV

Power 2

FPC 1 1.0v 999 mV

FPC 2 1.0v 999 mV

Power 3

FPC 2.5v 2500 mV

FPC 3.3v 3299 mV

Power 4

FPC 0.9v 899 mV

FPC 1.5v 1500 mV

Power 5

PE0 1 1.0v 1039 mV

PE0 2 1.0v 1039 mV

Power 6

PE0 1 0.9v 900 mV

PE0 2 0.9v 900 mV

Power 7

PE0 3 0.9v 898 mV

PE0 4 0.9v 899 mV

Power 8

PE0 H 0.9v 899 mV

PE0 H 1.2v 1199 mV

Power 9

PE1 1 1.0v 1040 mV

PE1 2 1.0v 1039 mV

Power 10

PE1 1 0.9v 926 mV

PE1 2 0.9v 926 mV

Power 11

PE1 3 0.9v 925 mV

PE1 4 0.9v 925 mV

Power 12

PE1 H 0.9v 900 mV

PE1 H 1.2v 1199 mV

Power 13

PE2 1 1.0v 1039 mV

PE2 2 1.0v 1039 mV

Power 14

PE2 1 0.9v 873 mV

PE2 2 0.9v 873 mV

Power 15	
PE2 3 0.9v	875 mV
PE2 4 0.9v	875 mV
Power 16	
PE2 H 0.9v	899 mV
PE2 H 1.2v	1199 mV
Power 17	
PE3 1 1.0v	1039 mV
PE3 2 1.0v	1039 mV
Power 18	
PE3 1 0.9v	899 mV
PE3 2 0.9v	900 mV
Power 19	
PE3 3 0.9v	899 mV
PE3 4 0.9v	899 mV
Power 20	
PE3 H 0.9v	899 mV
PE3 H 1.2v	1199 mV
Power 21	
PE4 1 1.0v	1040 mV
PE4 2 1.0v	1040 mV
Power 22	
PE4 1 0.9v	949 mV
PE4 2 0.9v	950 mV
Power 23	
PE4 3 0.9v	950 mV
PE4 4 0.9v	951 mV
Power 24	
PE4 H 0.9v	899 mV
PE4 H 1.2v	1199 mV
Power 25	
PE5 1 1.0v	1039 mV
PE5 2 1.0v	1039 mV
Power 26	
PE5 1 0.9v	900 mV
PE5 2 0.9v	900 mV
Power 27	
PE5 3 0.9v	900 mV
PE5 4 0.9v	900 mV
Power 28	
PE5 H 0.9v	899 mV
PE5 H 1.2v	1199 mV
Power 29	

```

    PIC0 12.0v          0 mV
Power 30
    PIC1 12.0v          0 mV
Power 31
    A   12.0v          12406 mV
    B   12.0v          1008 mV
Bus Revision          115
FPC 6 status:
State                 Onlining
Bus Revision          115

```

Release Information

Command introduced before Junos OS Release 7.4.

satellite option introduced in Junos OS Release 14.2R3.

RELATED DOCUMENTATION

[request chassis fpc](#)

[show chassis fpc](#)

[show chassis fpc-feb-connectivity](#)

[Resynchronizing FPC Sequence Numbers with Active FPCs when an FPC Comes Online](#)

[MX960 Flexible PIC Concentrator Description](#)

show chassis environment pem

IN THIS SECTION

- [Syntax](#) | **480**
- [Syntax \(ACX4000 Router\)](#) | **480**
- [Syntax \(TX Matrix Routers\)](#) | **480**
- [Syntax \(TX Matrix Plus Routers\)](#) | **480**
- [Syntax \(MX Series Router\)](#) | **481**

- [Syntax \(PTX Series Router\) | 481](#)
- [Syntax \(MX104 Universal Routing Platforms\) | 481](#)
- [Syntax \(MX10003, MX204, MX10004, MX10008, OCX Series, EX9251, and EX9253 devices\) | 481](#)
- [Syntax \(QFX Series\) | 481](#)
- [Description | 482](#)
- [Options | 482](#)
- [Required Privilege Level | 483](#)
- [Output Fields | 483](#)
- [Sample Output | 485](#)
- [Release Information | 500](#)

Syntax

```
show chassis environment pem  
<slot>
```

Syntax (ACX4000 Router)

```
show chassis environment pem
```

Syntax (TX Matrix Routers)

```
show chassis environment pem  
<lcc number | scc>  
<slot>
```

Syntax (TX Matrix Plus Routers)

```
show chassis environment pem  
<lcc number | sfc number>  
<slot>
```

Syntax (MX Series Router)

```
show chassis environment pem  
<slot>  
<all-members>  
<local>  
<member member-id>
```

Syntax (PTX Series Router)

```
show chassis environment pem  
<slot>  
<all-members>  
<local>  
<member member-id>
```

Syntax (MX104 Universal Routing Platforms)

```
show chassis environment pem  
<slot>  
<satellite [fpc-slot slot-id |device-alias alias-name]
```

Syntax (MX10003, MX204, MX10004, MX10008, OCX Series, EX9251, and EX9253 devices)

```
show chassis environment pem  
<slot>
```

Syntax (QFX Series)

```
show chassis environment pem  
<slot (interconnect-device name slot ) | (node-device name)>
```

Description

Display Power Entry Module (PEM) environmental status information.

NOTE: The new high-capacity (4100W) enhanced DC PEM on MX960 routers includes a new design that can condition the input voltage. This results in the output voltage differing from the input voltage. The earlier generation of DC PEMs coupled the input power directly to the output, thereby making it safe to assume that the output voltage was equal to the input voltage.

Options

none	Display environmental information about both PEMs. For the TX Matrix router, display environmental information about the PEMs, the TX Matrix router, and its attached T640 routers. For the TX Matrix Plus router, display environmental information about the PEMs, the TX Matrix Plus router, and its attached routers.
all-members	(MX Series routers only) (Optional) Display environmental information about the PEMs in all the member routers of the Virtual Chassis configuration.
interconnect-device <i>name</i>	(QFabric systems only) (Optional) Display chassis environmental information about the PEMs in the Interconnect device.
lcc <i>number</i>	<p>(TX Matrix router and TX Matrix Plus router only) (Optional) Line-card chassis number.</p> <p>Replace <i>number</i> with the following values depending on the LCC configuration:</p> <ul style="list-style-type: none"> • 0 through 3, when T640 routers are connected to a TX Matrix router in a routing matrix. • 0 through 3, when T1600 routers are connected to a TX Matrix Plus router in a routing matrix. • 0 through 7, when T1600 routers are connected to a TX Matrix Plus router with 3D SIBs in a routing matrix. • 0, 2, 4, or 6, when T4000 routers are connected to a TX Matrix Plus router with 3D SIBs in a routing matrix.
local	(MX Series routers only) (Optional) Display environmental information about the PEM in the local Virtual Chassis member.

member <i>member-id</i>	(MX Series routers only) (Optional) Display environmental information about the PEM in the specified member of the Virtual Chassis configuration. Replace <i>member-id</i> with a value of 0 or 1.
node-device <i>name</i>	(QFabric systems only) (Optional) Display chassis environmental information about the PEMs in the Node device.
satellite [fpc-slot <i>slot-id</i> device-alias <i>alias-name</i>]	(Junos Fusion only)(Optional) Display environmental information about the PEM in the specified satellite device in a Junos Fusion, or for all satellite devices in the Junos Fusion if no satellite devices are specified.
scc	(TX Matrix routers only) (Optional) Display environmental information about the PEM in the TX Matrix router (or switch-card chassis).
sfc	(TX Matrix Plus routers only) (Optional) Display environmental information about the PEM in the TX Matrix Plus router (or switch-fabric chassis).
slot	(Optional) Display environmental information about an individual PEM. Replace <i>slot</i> with 0 or 1.

Required Privilege Level

view

Output Fields

[Table 16 on page 483](#) lists the output fields for the `show chassis environment pem` command. Output fields are listed in the approximate order in which they appear.

Table 16: show chassis environment pem Output Fields

Field Name	Field Description
PEM <i>slot</i> status	Number of the PEM slot.

Table 16: show chassis environment pem Output Fields (Continued)

Field Name	Field Description
State	<p>Status of the PEM.</p> <p>NOTE: PEM with no feeds connected at bootup on MX10004 and MX10008 devices, continues to stay in "Present" state until feeds are connected to it. PEM with feeds connected at bootup, continues to move to OFFLINE state. "Present" state is only a transitional state that can either move to OFFLINE (or) ONLINE depending on the PEM output. For example, a PEM with no feeds connected at bootup, moves through the states from "Empty" to "Present" to "Offline" state.</p>
Temperature	Temperature of the air flowing past the PEM.
AC Input	Status of the AC input for the specified component
AC Output	Status of the AC output for the specified component.
DC input	Status of the DC input for the specified component.
DC output	Status of the DC output for the specified component.
Load	(Not available on M40e or M160 routers) Information about the load on supply, in percentage of rated current being used.
Voltage	<p>(M120, M160, M320, T640, T1600, TX Matrix, and TX Matrix Plus routers only) Information about voltage supplied to the PEM.</p> <p>(MX104 routers only) Information about voltage supplied by the PEM to the system.</p>
Current	(T640, T1600, TX Matrix, and TX Matrix Plus routers only) Information about the PEM current.
Power	(T640, T1600, TX Matrix, and TX Matrix Plus routers only) Information about the PEM power.
SCG/CB/SIB	(T640, T1600, TX Matrix, and TX Matrix Plus routers only) SONET Clock Generator/Control Board/Switch Interface Board.

Table 16: show chassis environment pem Output Fields (Continued)

Field Name	Field Description
FAN	(T640, T1600, and T4000 routers with six-input DC power supply only) Information about the DC output to the fan.

Sample Output

show chassis environment pem (M40e Router)

```

user@host> show chassis environment pem
PEM 0 status:
  State           Online
  Temperature     OK
  AC input        OK
  DC output       OK

```

show chassis environment pem (M120 Router)

```

user@host> show chassis environment pem
PEM 0 status:
  State           Online
  Temperature     OK
  DC Input:       OK
  DC Output:      OK
  Load            Less than 20 percent
  Voltage:
    48.0 V input  52864 mV
    48.0 V fan supply 41655 mV
    3.3 V         3399 mV
PEM 1 status:
  State           Online
  Temperature     OK
  DC Input:       OK
  DC Output:      OK
  Load            Less than 20 percent
  Voltage:

```

48.0 V input	54537 mV
48.0 V fan supply	42910 mV
3.3 V	3506 mV

show chassis environment pem (M160 Router)

```

user@host> show chassis environment pem
PEM 0 status:
  State                Online
  Temperature           OK
  DC input              OK
  DC output             OK
  Load                  Less than 20 percent
  Voltage:
    48.0 V input        54833 mV
    48.0 V fan supply   50549 mV
    8.0 V bias          8239 mV
    5.0 V bias          5006 mV

```

show chassis environment pem (M320 Router)

```

user@host> show chassis environment pem
PEM 2 status:
  State                Online
  Temperature           OK
  DC input              OK
  Load                  Less than 40 percent
    48.0 V input        51853 mV
    48.0 V fan supply   48877 mV
    8.0 V bias          8449 mV
    5.0 V bias          4998 mV
PEM 3 status:
  State                Online
  Temperature           OK
  DC input              OK
  Load                  Less than 40 percent
    48.0 V input        51717 mV
    48.0 V fan supply   49076 mV

```

8.0 V bias	8442 mV
5.0 V bias	4998 mV

show chassis environment pem (MX150)

```

user@host> show chassis environment pem
FPC 0 PEM 0 status:
  State           Online
  Airflow         Front to Back
  Temperature      OK

```

show chassis environment pem (MX104 Router)

```

user@host> show chassis environment pem
PEM 0 status:
  State           Online
  Temperature      OK
  DC Output:      OK
  Voltage:
    12.0 V output  12281 mV
    3.3 V output   3353 mV
PEM 1 status:
  State           Empty

```

show chassis environment pem (MX240 Router)

```

user@host> show chassis environment pem
PEM 0 status:
  State           Online
  Temperature      OK
  DC Output:      OK
PEM 1 status:
  State           Online
  Temperature      OK
  DC Output:      OK

```

show chassis environment pem (MX480 Router)

```

user@host> show chassis environment pem
PEM 0 status:
  State           Online
  Temperature     OK
  DC Input:       OK
  DC Output:      OK
  Voltage:
PEM 1 status:
  State           Online
  Temperature     OK
  DC Input:       OK
  DC Output:      OK
  Voltage:

```

show chassis environment pem (MX960 Router)

```

user@host> show chassis environment pem
PEM 2 status:
  State           Present
PEM 3 status:
  State           Online
  Temperature     OK
  DC Output:      OK

```

show chassis environment pem (MX10003 Router)

```

user@host> show chassis environment pem

PEM 0 status:
  State           Online
  Airflow         Front to Back
  Temperature     OK   34 degrees C / 93 degrees F
  Temperature     OK   26 degrees C / 78 degrees F
  Temperature     OK   24 degrees C / 75 degrees F
  Firmware version 0x22
  Cooling Fan     8752 RPM
  DC Output       Voltage(V) Current(A) Power(W) Load(%)

```

```

12.00    26          312    10
PEM 1 status:
  State           Online
  Airflow         Front to Back
  Temperature     OK   35 degrees C / 95 degrees F
  Temperature     OK   26 degrees C / 78 degrees F
  Temperature     OK   25 degrees C / 77 degrees F
  Firmware version 0x22
  Cooling Fan     8480 RPM
  DC Output       Voltage(V) Current(A) Power(W) Load(%)
                  12.00    27          324    11
PEM 2 status:
  State           Online
  Airflow         Front to Back
  Temperature     OK   37 degrees C / 98 degrees F
  Temperature     OK   29 degrees C / 84 degrees F
  Temperature     OK   25 degrees C / 77 degrees F
  Firmware version 0x22
  Cooling Fan     8656 RPM
  DC Output       Voltage(V) Current(A) Power(W) Load(%)
                  12.00    25          300    10
PEM 3 status:
  State           Online
  Airflow         Front to Back
  Temperature     OK   35 degrees C / 95 degrees F
  Temperature     OK   26 degrees C / 78 degrees F
  Temperature     OK   25 degrees C / 77 degrees F
  Firmware version 0x22
  Cooling Fan     8448 RPM
  DC Output       Voltage(V) Current(A) Power(W) Load(%)
                  12.00    26          312    10
PEM 4 status:
  State           Empty
PEM 5 status:
  State           Empty

```

show chassis environment pem 0 (MX10004)

```

PEM 0 status:
  State           Online

```

```

Airflow                Front to Back
Temperature            OK   33 degrees C / 91 degrees F
Firmware version      AA17AA17.AB15AB15.AC27
Fan 0                 6848 RPM
Fan 1                 8032 RPM
DC Output              Voltage(V) Current(A) Power(W) Load(%)
                      12.00    72          864    15
Input                  Voltage(V) Current(A) Power(W)
INP 1                 201.4    5.0        1015.1
INP 2                 0.0      0.0         0.0
Health check Information:
  Status: Scheduled
  Last Result: Not Performed Yet
  Last Execution: Empty
  Next Scheduled Run: 2022-08-31 17:29:18

```

show chassis environment pem (MX204 Router)

```

user@host> show chassis environment pem

PEM 0 status:
  State                Empty
PEM 1 status:
  State                Online
  Airflow              Front to Back
  Temperature          OK   48 degrees C / 118 degrees F
  Temperature          OK   51 degrees C / 123 degrees F
  Fan Sensor           5400 RPM
  DC Output             Voltage(V) Current(A) Power(W) Load(%)
                      11.94    16          191    29

```

show chassis environment pem (MX10008 Router)

```

user@host> show chassis environment pem

PEM 0 status:
  State                Online
  Airflow              Front to Back
  Temperature          OK   29 degrees C / 84 degrees F
  Firmware version     0x36
  Fan 0               5880 RPM

```

```

DC Output          Voltage(V) Current(A) Power(W) Load(%)
                  12.00      104      1248    46

PEM 1 status:
State              Online
Airflow           Front to Back
Temperature        OK    27 degrees C / 80 degrees F
Firmware version   0x36
Fan 0             5940 RPM
DC Output          Voltage(V) Current(A) Power(W) Load(%)
                  12.00      104      1248    46

PEM 2 status:
State              Online
Airflow           Front to Back
Temperature        OK    30 degrees C / 86 degrees F
Firmware version   0x36
Fan 0             5940 RPM
DC Output          Voltage(V) Current(A) Power(W) Load(%)
                  12.00      105      1260    46

PEM 3 status:
State              Present

PEM 4 status:
State              Present

PEM 5 status:
State              Present

```

show chassis environment pem (PTX10016 Router)

```

user@host> show chassis environment pem
PEM 0 status:
State              Online
Airflow           Front to Back
Temperature        OK    21 degrees C / 69 degrees F
Firmware version   0x36
Fan 0             5760 RPM
DC Output          Voltage(V) Current(A) Power(W) Load(%)
                  12.00      51      612     22

PEM 1 status:
State              Online
Airflow           Front to Back
Temperature        OK    23 degrees C / 73 degrees F
Firmware version   0x36

```

```

Fan 0                5760 RPM
DC Output            Voltage(V) Current(A) Power(W) Load(%)
                    12.00      52         624     23

PEM 2 status:
State                Online
Airflow              Front to Back
Temperature           OK   23 degrees C / 73 degrees F
Firmware version     0x36
Fan 0                5760 RPM
DC Output            Voltage(V) Current(A) Power(W) Load(%)
                    12.00      51         612     22

PEM 3 status:
State                Online
Airflow              Front to Back
Temperature           OK   21 degrees C / 69 degrees F
Firmware version     0x36
Fan 0                5760 RPM
DC Output            Voltage(V) Current(A) Power(W) Load(%)
                    12.00      51         612     22

PEM 4 status:
State                Online
Airflow              Front to Back
Temperature           OK   22 degrees C / 71 degrees F
Firmware version     0x36
Fan 0                5760 RPM
DC Output            Voltage(V) Current(A) Power(W) Load(%)
                    12.00      52         624     23

PEM 5 status:
State                Online
Airflow              Front to Back
Temperature           OK   24 degrees C / 75 degrees F
Firmware version     0x36
Fan 0                5700 RPM
DC Output            Voltage(V) Current(A) Power(W) Load(%)
                    12.00      51         612     22

PEM 6 status:
State                Online
Airflow              Front to Back
Temperature           OK   21 degrees C / 69 degrees F
Firmware version     0x36
Fan 0                5700 RPM

```

DC Output	Voltage(V)	Current(A)	Power(W)	Load(%)
	12.00	50	600	22

show chassis environment pem (T320 Router)

```
user@host> show chassis environment pem
PEM 0 status:
  State           Online
  Temperature      OK
  DC input:       OK
```

show chassis environment pem (T640 Router)

```
user@host> show chassis environment pem
PEM 0 status:
  State           Online
  Temperature      22 degrees C / 71 degrees F
  AC input: OK
  DC output:
    Voltage  Current  Power  Load
    FPC 0    56875   606    34    4
    FPC 1    57016   525    29    3
    FPC 2     0      0      0     0
    FPC 3     0      0      0     0
    FPC 4     0      0      0     0
    FPC 5     0      0      0     0
    FPC 6    57158  1581    90    12
    FPC 7     0      0      0     0
  SCG/CB/SIB    56750  1125    63    5
```

show chassis environment pem (T4000 Router)

```
user@host> show chassis environment pem
PEM 0 status:
  State           Online
  Temperature      33 degrees C / 91 degrees F
  DC Input:       OK
    Voltage(V)  Current(A)  Power(W)  Load(%)
  INPUT 0      54.625     9.812     535      22
```

INPUT 1	54.625	10.250	559	23
INPUT 2	55.125	0.125	6	0
INPUT 3	54.500	10.062	548	22
INPUT 4	54.750	9.375	513	21
INPUT 5	54.750	10.187	557	23
DC Output	Voltage(V)	Current(A)	Power(W)	Load(%)
FPC 0	55.750	10.125	564	37
FPC 1	51.625	0.000	0	0
FPC 2	52.000	0.000	0	0
FPC 3	55.062	10.437	574	38
FPC 4	52.125	0.000	0	0
FPC 5	55.000	9.375	515	34
FPC 6	55.187	9.687	534	35
FPC 7	51.437	0.000	0	0
SCG/CB/SIB	55.375	15.750	872	35
FAN	54.562	14.750	804	42

show chassis environment pem (T640/T1600/T4000 Routers With Six-Input DC Power Supply)

```

user@host> show chassis environment pem
PEM 1 status:
  State                Online
  Temperature          36 degrees C / 96 degrees F
  DC Input:           OK
    Voltage(V)  Current(A)  Power(W)  Load(%)
  INPUT 0      0.000      0.000      0         0
  INPUT 1      54.875      3.812      209       27
  INPUT 2      55.375      3.937      218       29
  INPUT 3      54.625      3.750      204       27
  INPUT 4      55.125      3.375      186       24
  INPUT 5      55.125      3.375      186       24
  DC Output    Voltage(V)  Current(A)  Power(W)  Load(%)
  FPC 0        52.312      0.000      0         0
  FPC 1        52.687      0.000      0         0
  FPC 2        52.812      0.000      0         0
  FPC 3        55.812      7.062      394       52
  FPC 4        52.625      0.000      0         0
  FPC 5        52.625      0.000      0         0
  FPC 6        52.750      0.000      0         0
  FPC 7        52.750      0.000      0         0

```

SCG/CB/SIB	55.937	11.937	667	55
FAN	55.812	4.937	275	36

show chassis environment pem lcc (TX Matrix Routing Matrix)

```

user@host> show chassis environment pem 0 lcc
0
lcc0-re0:
-----
PEM 0 status:
State                Present
Temperature          27 degrees C / 80 degrees F
DC input:            Check
DC output:           Voltage  Current    Power    Load
  FPC 0                0         0         0        0
  FPC 1                0         0         0        0
  FPC 2                0         0         0        0
  FPC 3                0         0         0        0
  FPC 4                0         0         0        0
  FPC 5                0         0         0        0
  FPC 6                0         0         0        0
  FPC 7                0         0         0        0
SCG/CB/SIB           0         0         0        0

```

show chassis environment pem scc (TX Matrix Routing Matrix)

```

user@host> show chassis environment pem scc
scc-re0:
-----
PEM 1 status:
State                Online
Temperature          24 degrees C / 75 degrees F
DC input:            OK
DC output:           Voltage  Current    Power    Load
  SIB 0                0         0         0        0
  SIB 1                0         0         0        0
  SIB 2                0         0         0        0
  SIB 3               56550         0         0        0
  SIB 4               55958        6912        386       51

```

show chassis environment pem sfc (TX Matrix Plus Routing Matrix)

```

user@host> show chassis environment pem sfc
0
sfc0-re0:
-----
PEM 0 status:
State                Online
Temperature          35 degrees C / 95 degrees F
DC Input:            OK
DC Output            Voltage   Current   Power   Load
Channel 0            53820    14140    761     59
Channel 1            53550    12720    681     53
Channel 2            53840    12930    696     54
Channel 3            53690    14990    804     63
Channel 4            53620    15070    808     63
Channel 5            53900    14820    798     62
Channel 6            54120    5020     271     21

```

show chassis environment pem lcc (TX Matrix Plus Routing Matrix)

```

user@host> show chassis environment lcc 0
lcc0-re1:
-----
PEM 0 status:
State                Online
Temperature          38 degrees C / 100 degrees F
DC Input:            OK
DC Output            Voltage   Current   Power   Load
FPC 0                0         0         0       0
FPC 1                0         0         0       0
FPC 2                0         0         0       0
FPC 3                0         0         0       0
FPC 4                56408    7575     427     56
FPC 5                0         0         0       0
FPC 6                56266    7956     447     59
FPC 7                56283    6100     343     45
SCG/CB/SIB          55916    8950     500     41
PEM 1 status:

```

```

State                Present
Temperature          35 degrees C / 95 degrees F
DC Input:           Check
DC Output           Voltage  Current    Power    Load
  FPC 0             0         0         0        0
  FPC 1             0         0         0        0
  FPC 2             0         0         0        0
  FPC 3             0         0         0        0
  FPC 4             0         0         0        0
  FPC 5             0         0         0        0
  FPC 6             0         0         0        0
  FPC 7             0         0         0        0
  SCG/CB/SIB       0         0         0        0

```

show chassis environment pem node-device (QFabric System)

```

user@switch> show chassis environment pem node-device
node1
FPC 0 PEM 0 status:
  State                Check
  Airflow              Front to Back
  Temperature          OK
  AC Input:            OK
  DC Output           Voltage(V) Current(A) Power(W) Load(%)
                    12         10         120    18
FPC 0 PEM 1 status:
  State                Online
  Airflow              Back to Front
  Temperature          OK
  AC Input:            OK
  DC Output           Voltage(V) Current(A) Power(W) Load(%)
                    11         10         110    17

```

show chassis environment pem (QFX Series and OCX Series)

```

user@switch> show chassis environment pem
FPC 0 PEM 1 status:
  State                Online
  Airflow              Front to Back
  Temperature          OK

```

```

AC Input:          OK
DC Output          Voltage(V) Current(A) Power(W) Load(%)
                  12          17          204     31

```

show chassis environment pem (QFX 10016)

```

user@router> show chassis environment pem 1

PEM 1 status:
State          Present
Input          Voltage(V) Current(A) Power(W)
INP 1         229.9      0.4      96.6
INP 2         233.7      0.4      98.2
Health check Information:
Status:        Scheduled
Last Result:   Pass
Last Execution: 2019-04-23 15:09:54
Next Scheduled Run: 2019-04-23 15:32:59

```

show chassis environment pem interconnect-device (QFabric System)

```

user@switch> show chassis environment pem interconnect-device
IC1 1
IC1 PEM 1 status:
State          Online
Airflow        Front to Back
Temperature    OK
AC Input:      OK
DC Output      Voltage(V) Current(A) Power(W) Load(%)
              12          18          216     33

```

show chassis environment pem (EX9251 Switches)

```

user@switch> show chassis environment pem
PEM 0 status:
State          Present
PEM 1 status:
State          Online

```

```

Airflow          Front to Back
Temperature      OK   36 degrees C / 96 degrees F
Temperature      OK   35 degrees C / 95 degrees F
Fan Sensor       5940 RPM
DC Output        Voltage(V) Current(A) Power(W) Load(%)
                  11.85      17          201    30

```

show chassis environment pem (EX9253 Switches)

```

user@switch> show chassis environment pem
PEM 0 status:
  State          Online
  Airflow        Front to Back
  Temperature    OK   56 degrees C / 132 degrees F
  Temperature    OK   46 degrees C / 114 degrees F
  Temperature    OK   28 degrees C / 82 degrees F
  Firmware version 04.10
  Cooling Fan    9056 RPM
  DC Output      Voltage(V) Current(A) Power(W) Load(%)
                  12.00      47          564    19
PEM 1 status:
  State          Present
PEM 2 status:
  State          Empty
PEM 3 status:
  State          Empty
PEM 4 status:
  State          Present
PEM 5 status:
  State          Online
  Airflow        Front to Back
  Temperature    OK   61 degrees C / 141 degrees F
  Temperature    OK   49 degrees C / 120 degrees F
  Temperature    OK   28 degrees C / 82 degrees F
  Firmware version 04.10
  Cooling Fan    8656 RPM
  DC Output      Voltage(V) Current(A) Power(W) Load(%)
                  12.00      51          612    21

```

show chassis environment pem (PTX1000 Packet Transport Routers)

```

user@router> show chassis environment pem

PEM 0 status:
  State           Online
  Airflow         Front to Back
  Temp Sensor 0   OK   22 degrees C / 71 degrees F
  Temp Sensor 1   OK   23 degrees C / 73 degrees F
  Fan 0           9184 RPM
  Fan 1           7936 RPM
  DC Output       Voltage(V) Current(A) Power(W) Load(%)
                  12          24          288    18

PEM 2 status:
  State           Online
  Airflow         Front to Back
  Temp Sensor 0   OK   22 degrees C / 71 degrees F
  Temp Sensor 1   OK   26 degrees C / 78 degrees F
  Fan 0           9056 RPM
  Fan 1           7808 RPM
  DC Output       Voltage(V) Current(A) Power(W) Load(%)
                  12          24          288    18

```

On PTX1000 Packet Transport Routers, you cannot view the `show chassis environment pem` output at the PEM slot level, by using the command `show chassis environment pem slot`.

Release Information

Command introduced before Junos OS Release 7.4.

`satellite` option introduced in Junos OS Release 14.2R3.

RELATED DOCUMENTATION

| [show chassis hardware](#)

show chassis environment routing-engine

IN THIS SECTION

- [Syntax | 501](#)
- [Syntax \(TX Matrix Routers\) | 501](#)
- [Syntax \(TX Matrix Plus Routers\) | 502](#)
- [Syntax \(MX104, MX2010, MX2020, MX10003, MX204, and MX2008 Universal Routing Platforms\) | 502](#)
- [Syntax \(MX Series and PTX Series Devices\) | 502](#)
- [Syntax \(QFX Series and OCX Series\) | 502](#)
- [Syntax \(EX9251 and EX9253 Switches; ACX500, ACX5048 and ACX5096 Routers\) | 502](#)
- [Description | 502](#)
- [Options | 503](#)
- [Required Privilege Level | 504](#)
- [Output Fields | 504](#)
- [Sample Output | 505](#)
- [Sample Output | 509](#)
- [Release Information | 510](#)

Syntax

```
show chassis environment routing-engine  
<slot>
```

Syntax (TX Matrix Routers)

```
show chassis environment routing-engine  
<lcc number | scc>  
<slot>
```

Syntax (TX Matrix Plus Routers)

```
show chassis environment routing-engine
<lcc number | sfc number>
<slot>
```

Syntax (MX104, MX2010, MX2020, MX10003, MX204, and MX2008 Universal Routing Platforms)

```
show chassis environment routing-engine
<slot>
<satellite [fpc-slot slot-id |device-alias alias-name]
```

Syntax (MX Series and PTX Series Devices)

```
show chassis environment routing-engine
<slot>
<all-members>
<local>
<member member-id>
```

Syntax (QFX Series and OCX Series)

```
show chassis environment routing-engine
interconnect-device name
```

Syntax (EX9251 and EX9253 Switches; ACX500, ACX5048 and ACX5096 Routers)

```
show chassis environment routing-engine
```

Description

Display Routing Engine environmental status information.

Options

none	Display environmental information about all Routing Engines. For a TX Matrix router, display environmental information about all Routing Engines on the TX Matrix router and its attached T640 routers. For a TX Matrix Plus router, display environmental information about all Routing Engines on the TX Matrix Plus router and its attached routers.
all-members	(MX Series routers only) (Optional) Display environmental information about the Routing Engines in all member routers in the Virtual Chassis configuration.
interconnect-device <i>name</i>	(QFabric systems only) (Optional) Display environmental information about the Routing Engines for the Interconnect device.
lcc <i>number</i>	<p>–(TX Matrix router and TX Matrix Plus router only) (Optional) Line-card chassis number.</p> <p>Replace <i>number</i> with the following values depending on the LCC configuration:</p> <ul style="list-style-type: none"> • 0 through 3, when T640 routers are connected to a TX Matrix router in a routing matrix. • 0 through 3, when T1600 routers are connected to a TX Matrix Plus router in a routing matrix. • 0 through 7, when T1600 routers are connected to a TX Matrix Plus router with 3D SIBs in a routing matrix. • 0, 2, 4, or 6, when T4000 routers are connected to a TX Matrix Plus router with 3D SIBs in a routing matrix.
local	(MX Series routers only) (Optional) Display environmental information about the Routing Engines in the local Virtual Chassis member.
member <i>member-id</i>	(MX Series routers only) (Optional) Display environmental information about the Routing Engines in the specified member in the Virtual Chassis configuration. Replace <i>member-id</i> with the value of 0 or 1.
satellite [fpc-slot <i>slot-id</i>] device-alias <i>alias-name</i>	(Junos Fusion only)(Optional) Display environmental information for the specified satellite device in a Junos Fusion, or for all satellite devices in the Junos Fusion if no satellite devices are specified.
scc	(TX Matrix router only) (Optional) Display environmental information about the Routing Engine in the TX Matrix router (switch-card chassis).

- sfc** (TX Matrix Plus router only) (Optional) Display environmental information about the Routing Engine in the TX Matrix Plus router (or switch-fabric chassis).
- slot** (Optional) Display environmental information about an individual Routing Engine. On M10i, M20, M40e, M120, M160, M320, MX Series, MX104 routers, MX2010 routers, MX2020 routers, MX2008 routers, and T Series routers, replace *slot* with 0 or 1. On M5, M7i, M10, and M40 routers, replace *slot* with 0. On EX3200 and EX4200 standalone switches, replace *slot* with 0. On EX4200 switches in a Virtual Chassis configuration and on EX8208 and EX8216 switches, replace *slot* with 0 or 1. On the QFX3500 and QFX5700, there is only one Routing Engine, so you do not need to specify the slot number. On PTX Series Packet Transport Routers, replace *slot* with 0 or 1.

Required Privilege Level

view

Output Fields

[Table 17 on page 504](#) lists the output fields for the `show chassis environment routing-engine` command. Output fields are listed in the approximate order in which they appear.

Table 17: show chassis environment routing-engine Output Fields

Field Name	Field Description
Routing engine <i>slot</i> status	Number of the Routing Engine slot: 0 or 1.
State	Status of the Routing Engine: <ul style="list-style-type: none"> • Online Primary—Routing Engine is online, operating as Primary. • Online Standby—Routing Engine is online, operating as Standby. • Offline—Routing Engine is offline.
Temperature	Temperature of the air flowing past the Routing Engines
CPU Temperature	(PTX Series and T4000 Core Routers only) Temperature of the air flowing past the Routing Engine CPU.

Sample Output

show chassis environment routing-engine (Nonredundant)

```
user@host> show chassis environment routing-engine
Routing Engine 0 status:
  State                Online Master
  Temperature           27 degrees C / 80 degrees
```

show chassis environment routing-engine (Redundant)

```
user@host> show chassis environment routing-engine
Route Engine 0 status:
  State:                Online Master
  Temperature:          26 degrees C / 78 degrees F
Route Engine 1 status:
  State:                Online Standby
  Temperature:          26 degrees C / 78 degrees F
```

show chassis environment routing-engine (MX150)

```
user@ host >show chassis environment routing-engine
Routing Engine 0 status:
  State                Online Master
  CPU Temperature       42 degrees C / 107 degrees F
```

show chassis environment routing-engine (MX104 Router)

```
user@ host >show chassis environment routing-engine
Routing Engine 0 status:
  State                Online Master
  Temperature           34 degrees C / 93 degrees F
  CPU Temperature       43 degrees C / 109 degrees F
Routing Engine 1 status:
  State                Online Standby
```

```

Temperature          33 degrees C / 91 degrees F
CPU Temperature       39 degrees C / 102 degrees F

```

show chassis environment routing-engine (MX2010 Router)

```

user@host> show chassis environment routing-engine
Routing Engine 0 status:
  State              Online Master
  Temperature        37 degrees C / 98 degrees F
  CPU Temperature    37 degrees C / 98 degrees F
Routing Engine 1 status:
  State              Online Standby
  Temperature        35 degrees C / 95 degrees F
  CPU Temperature    34 degrees C / 93 degrees F

```

show chassis environment routing-engine (MX2020 Router)

```

user@host> show chassis environment routing-engine
Routing Engine 0 status:
  State              Online Master
  Temperature        35 degrees C / 95 degrees F
  CPU Temperature    34 degrees C / 93 degrees F
Routing Engine 1 status:
  State              Online Standby
  Temperature        44 degrees C / 111 degrees F
  CPU Temperature    43 degrees C / 109 degrees F

```

show chassis environment routing-engine (MX2008 Router)

```

user@host> show chassis environment routing-engine
Routing Engine 0 status:
  State              Online Master
  CPU Temperature    75 degrees C / 167 degrees F
Routing Engine 1 status:
  State              Online Standby
  CPU Temperature    47 degrees C / 116 degrees F

```

show chassis environment routing-engine (TX Matrix Plus Router)

```

user@host> show chassis environment routing-engine
sfc0-re0:
-----
Routing Engine 0 status:
  State           Online Master
  Temperature     26 degrees C / 78 degrees F
Routing Engine 1 status:
  State           Online Standby
  Temperature     28 degrees C / 82 degrees F

lcc0-re0:
-----
Routing Engine 0 status:
  State           Online Master
  Temperature     30 degrees C / 86 degrees F
Routing Engine 1 status:
  State           Online Standby
  Temperature     29 degrees C / 84 degrees F

```

show chassis environment routing-engine (T4000 Core Router)

```

user@host> show chassis environment routing-engine
Routing Engine 0 status:
  State           Online Master
  Temperature     33 degrees C / 91 degrees F
  CPU Temperature 50 degrees C / 122 degrees F
Routing Engine 1 status:
  State           Online Standby
  Temperature     33 degrees C / 91 degrees F
  CPU Temperature 46 degrees C / 114 degrees F

```

show chassis environment routing-engine (QFX Series and OCX Series)

```

user@switch> show chassis environment routing-engine
Routing Engine 0 status:
  State           Online Master
  CPU Temperature 42 degrees C / 107 degrees F

```

```

Routing Engine 1 status:
  State           Online Standby
  CPU Temperature 34 degrees C / 93 degrees F

```

show chassis environment routing-engine interconnect-device (QFabric System)

```

user@switch> show chassis environment routing-engine
interconnect-device interconnect1
routing-engine interconnect-device interconnect1
Routing Engine 0 status:
  State           Online Standby
  Temperature     52 degrees C / 125 degrees F
Routing Engine 1 status:
  State           Online Master
  Temperature     57 degrees C / 134 degrees F

```

show chassis environment routing-engine (PTX5000 Packet Transport Router)

```

user@switch> show chassis environment routing-engine
Routing Engine 0 status:
  State           Online Master
  Temperature     55 degrees C / 131 degrees F
  CPU Temperature 66 degrees C / 150 degrees F
Routing Engine 1 status:
  State           Online Standby
  Temperature     52 degrees C / 125 degrees F
  CPU Temperature 64 degrees C / 147 degrees F

```

show chassis environment routing-engine (PTX10008 Router)

```

user@switch> show chassis environment routing-engine
Routing Engine 0 status:
  State           Online Master
  CPU Temperature 40 degrees C / 104 degrees F
Routing Engine 1 status:
  State           Online Standby
  CPU Temperature 40 degrees C / 104 degrees F

```

show chassis environment routing-engine (PTX10016 Router)

```

user@switch> show chassis environment routing-engine
Routing Engine 0 status:
  State                Online Master
  CPU Temperature      33 degrees C / 91 degrees F
Routing Engine 1 status:
  State                Online Standby
  CPU Temperature      38 degrees C / 100 degrees F

```

show chassis environment routing-engine (ACX5048 and ACX5096 Routers)

```

user@host> show chassis environment routing-engine
Routing Engine 0 status:
  State                Online Master
  Temperature          33 degrees C / 91 degrees F

```

show chassis environment routing-engine (ACX500 Routers)

```

user@host> show chassis environment routing-engine
Routing Engine 0 status:
  State                Online Master
  Temperature          54 degrees C / 129 degrees F

```

Sample Output**show chassis environment routing-engine (PTX5000 (RE-PTX-X8-64G), MX240 (RE-S-X6-64G), MX480 (RE-S-X6-64G), MX960 (RE-S-X6-64G), MX2010 (RE-MX2K-X8-64G), MX2020 (RE-MX2K-X8-64G))**

```

user@switch> show chassis environment routing-engine
Routing Engine 0 status:
  State                Online Master
  Temperature          37 degrees C / 98 degrees F
  CPU Temperature      52 degrees C / 125 degrees F
Routing Engine 1 status:
  State                Online Standby

```



```

Temperature          37 degrees C / 98 degrees F
CPU Temperature      51 degrees C / 123 degrees F

```

show chassis environment routing-engine (MX204 Routers)

```

user@host> show chassis environment routing-engine
Routing Engine 0 status:
  State                Online Master

```

show chassis environment routing-engine (MX10008 Routers)

```

Routing Engine 0 status:
  State                Online Master
  CPU Temperature      41 degrees C / 105 degrees F
Routing Engine 1 status:
  State                Online Standby
  CPU Temperature      40 degrees C / 104 degrees F

```

show chassis environment routing-engine (EX9251 Switches)

```

user@switch> show chassis environment routing-engine
Routing Engine 0 status:
  State                Online Master

```

show chassis environment routing-engine (EX9253 Switches)

```

user@switch> show chassis environment routing-engine
Routing Engine 0 status:
  State                Online Master
Routing Engine 1 status:
  State                Present

```

Release Information

Command introduced before Junos OS Release 7.4.

sfc option introduced in Junos OS Release 9.6 for the TX Matrix Plus router.

RELATED DOCUMENTATION

[request chassis routing-engine master](#)

show chassis routing-engine

show chassis fan

IN THIS SECTION

- [Syntax](#) | **511**
- [Syntax \(MX Series Routers\)](#) | **512**
- [Syntax \(MX104, MX204, MX2010, MX2020, MX2008, and MX10003 Universal Routing Platform\)](#) | **512**
- [Syntax \(QFX Series\)](#) | **512**
- [Syntax \(TX Matrix Router\)](#) | **512**
- [Syntax \(TX Matrix Plus Router\)](#) | **512**
- [Description](#) | **512**
- [Options](#) | **513**
- [Required Privilege Level](#) | **514**
- [Output Fields](#) | **514**
- [Sample Output](#) | **515**
- [Release Information](#) | **529**

Syntax

```
show chassis fan
```

Syntax (MX Series Routers)

```
show chassis fan
<all-members>
<local>
<member member-id>
```

Syntax (MX104, MX204, MX2010, MX2020, MX2008, and MX10003 Universal Routing Platform)

```
show chassis fan
<satellite [slot-id slot-id |device-alias alias-name]>
```

Syntax (QFX Series)

```
show chassis fan
<interconnect-device name>
```

Syntax (TX Matrix Router)

```
show chassis fan
<lcc number | scc>
```

Syntax (TX Matrix Plus Router)

```
show chassis fan
<lcc number | sfc number>
```

Description

(T Series routers, TX Matrix routers, TX Matrix Plus routers, M120 routers, M320 routers, MX104 routers, MX2010 routers, MX2020 routers, MX2008 routers, MX Series 5G Universal Routing Platforms, QFX3008-I Interconnect devices, QFX Series, OCX Series, EX Series switches, and PTX Series Packet Transport Routers only) Show information about the fan tray and fans.

Options

all-members	(MX Series routers only) (Optional) Display information about the fan tray and fans for all members of the Virtual Chassis configuration.
local	(MX Series routers only) (Optional) Display information about the fan tray and fans for the local Virtual Chassis member.
member <i>member-id</i>	(MX Series routers only) (Optional) Display information about the fan tray and fans for the specified member of the Virtual Chassis configuration. For an MX Series Virtual Chassis, replace <i>member-id</i> variable with a value 0 or 1.
interconnect-device <i>name</i>	(QFX3000-G QFabric systems only) (Optional) Display information about the fan tray and fans for the specified QFX3008-I Interconnect device.
lcc <i>number</i>	<p>(TX Matrix and TX Matrix Plus routers only) (Optional) On a TX Matrix router, display information about the fan tray and fans for the specified T640 router (line-card chassis) that is connected to a TX Matrix router. On a TX Matrix Plus router, display information about the fan tray and fans for the specified router (line-card chassis) that is connected to a TX Matrix Plus router.</p> <p>Replace <i>number</i> with the following values depending on the LCC configuration:</p> <ul style="list-style-type: none"> • 0 through 3, when T640 routers are connected to a TX Matrix router in a routing matrix. • 0 through 3, when T1600 routers are connected to a TX Matrix Plus router in a routing matrix. • 0 through 7, when T1600 routers are connected to a TX Matrix Plus router with 3D SIBs in a routing matrix. • 0, 2, 4, or 6, when T4000 routers are connected to a TX Matrix Plus router with 3D SIBs in a routing matrix.
satellite [slot-id slot-id device-alias <i>alias-name</i>]	(Junos Fusion only) (Optional) Display information about the fan tray and fans for the specified satellite device or devices in a Junos Fusion, or for all satellite devices if no satellite devices are specified.
scc	(TX Matrix routers only) (Optional) Display information about the fan tray and fans for the TX Matrix router (switch-card chassis).
sfc <i>number</i>	(TX Matrix Plus routers only) (Optional) Display information about the fan tray and fans for the TX Matrix Plus router (switch-fabric chassis). Replace <i>number</i> variable with 0.

Required Privilege Level

view

Output Fields

Table 18 on page 514 lists the output fields for the `show chassis fan` command. Output fields are listed in the approximate order in which they appear.

Table 18: show chassis fan Output Fields

Field Name	Field Description
Item	Fan item identifier.
Status	Status of the fan: <ul style="list-style-type: none"> • OK—Fan is running properly and within the normal range. • Check—Fan is in Check state because of some fault or alarm condition.
RPM	(T Series routers, TX Matrix routers, TX Matrix Plus routers, MX Series 5G Universal Routing Platforms, QFX3108 Interconnect devices, and EX Series switches only) Fan speed in revolutions per minute (RPM).
% RPM	(PTX10003, MX2010 routers, MX2020 routers, MX2008 routers, and PTX Series Packet Transport Routers only) Percentage of the fan speed being used.

Table 18: show chassis fan Output Fields (Continued)

Field Name	Field Description
Measurement	<p>(T Series routers, TX Matrix routers, TX Matrix Plus routers, MX Series 5G Universal Routing Platforms, QFX3108 Interconnect devices, and EX Series switches only) Fan speed status based on different chassis cooling requirements:</p> <ul style="list-style-type: none"> • Spinning at high speed • Spinning at intermediate speed • Spinning at normal speed • Spinning at low speed (except EX Series switches) <p>(PTX10003, MX2010 routers, MX2020 routers, MX2008 routers, and PTX Series Packet Transport Routers only) Fan speed in revolutions per minute (RPM) for each fan in the fan tray.</p>

Sample Output

show chassis fan

```
user@host> show chassis fan
```

```

Item                Status  RPM    Measurement
Top Tray Fan 1      OK      3790   Spinning at normal speed
Top Tray Fan 2      OK      3769   Spinning at normal speed
Top Tray Fan 3      OK      3769   Spinning at normal speed
Top Tray Fan 4      OK      3790   Spinning at normal speed
Top Tray Fan 5      OK      3790   Spinning at normal speed
Top Tray Fan 6      OK      3769   Spinning at normal speed
Top Tray Fan 7      OK      3790   Spinning at normal speed
Top Tray Fan 8      OK      3769   Spinning at normal speed
Top Tray Fan 9      OK      3769   Spinning at normal speed
Top Tray Fan 10     OK      3790   Spinning at normal speed
Top Tray Fan 11     OK      3790   Spinning at normal speed
Top Tray Fan 12     OK      3769   Spinning at normal speed
Bottom Tray Fan 1   OK      2880   Spinning at normal speed
Bottom Tray Fan 2   OK      2912   Spinning at normal speed

```

Bottom Tray Fan 3	OK	2928	Spinning at normal speed
Bottom Tray Fan 4	OK	2896	Spinning at normal speed
Bottom Tray Fan 5	OK	2896	Spinning at normal speed
Bottom Tray Fan 6	OK	2928	Spinning at normal speed

show chassis fan (QFabric Systems)

```
user@host> show chassis fan interconnect-device interconnect1
```

Item	Status	RPM	Measurement
TFT 0 Fan 0	OK	2849	Spinning at normal speed
TFT 0 Fan 1	OK	2821	Spinning at normal speed
TFT 0 Fan 2	OK	2735	Spinning at normal speed
TFT 0 Fan 3	OK	2815	Spinning at normal speed
TFT 0 Fan 4	OK	2828	Spinning at normal speed
TFT 0 Fan 5	OK	2863	Spinning at normal speed
BFT 1 Fan 0	OK	2941	Spinning at normal speed
BFT 1 Fan 1	OK	3008	Spinning at normal speed
BFT 1 Fan 2	OK	3073	Spinning at normal speed
BFT 1 Fan 3	OK	2925	Spinning at normal speed
BFT 1 Fan 4	OK	2863	Spinning at normal speed
BFT 1 Fan 5	OK	2933	Spinning at normal speed
SFT 0 Fan 0 Rotor 0	OK	15472	Spinning at normal speed
SFT 0 Fan 0 Rotor 1	OK	14477	Spinning at normal speed
SFT 0 Fan 1 Rotor 0	OK	15561	Spinning at normal speed
SFT 0 Fan 1 Rotor 1	OK	14210	Spinning at normal speed
SFT 0 Fan 2 Rotor 0	OK	16167	Spinning at normal speed
SFT 0 Fan 2 Rotor 1	OK	14248	Spinning at normal speed
SFT 0 Fan 3 Rotor 0	OK	16463	Spinning at normal speed
SFT 0 Fan 3 Rotor 1	OK	14099	Spinning at normal speed
SFT 1 Fan 0 Rotor 0	OK	15083	Spinning at normal speed
SFT 1 Fan 0 Rotor 1	OK	13533	Spinning at normal speed
SFT 1 Fan 1 Rotor 0	OK	16071	Spinning at normal speed
SFT 1 Fan 1 Rotor 1	OK	14400	Spinning at normal speed
SFT 1 Fan 2 Rotor 0	OK	15517	Spinning at normal speed
SFT 1 Fan 2 Rotor 1	OK	14210	Spinning at normal speed
SFT 1 Fan 3 Rotor 0	OK	16413	Spinning at normal speed
SFT 1 Fan 3 Rotor 1	OK	14400	Spinning at normal speed
SFT 2 Fan 0 Rotor 0	OK	15297	Spinning at normal speed
SFT 2 Fan 0 Rotor 1	OK	14634	Spinning at normal speed
SFT 2 Fan 1 Rotor 0	OK	15561	Spinning at normal speed

SFT 2 Fan 1 Rotor 1	OK	14285	Spinning at normal speed
SFT 2 Fan 2 Rotor 0	OK	15835	Spinning at normal speed
SFT 2 Fan 2 Rotor 1	OK	14400	Spinning at normal speed
SFT 2 Fan 3 Rotor 0	OK	15789	Spinning at normal speed
SFT 2 Fan 3 Rotor 1	OK	14323	Spinning at normal speed
SFT 3 Fan 0 Rotor 0	OK	16314	Spinning at normal speed
SFT 3 Fan 0 Rotor 1	OK	14876	Spinning at normal speed
SFT 3 Fan 1 Rotor 0	OK	15835	Spinning at normal speed
SFT 3 Fan 1 Rotor 1	OK	14323	Spinning at normal speed
SFT 3 Fan 2 Rotor 0	OK	16265	Spinning at normal speed
SFT 3 Fan 2 Rotor 1	OK	14594	Spinning at normal speed
SFT 3 Fan 3 Rotor 0	OK	16071	Spinning at normal speed
SFT 3 Fan 3 Rotor 1	OK	14323	Spinning at normal speed
SFT 4 Fan 0 Rotor 0	OK	15652	Spinning at normal speed
SFT 4 Fan 0 Rotor 1	OK	14438	Spinning at normal speed
SFT 4 Fan 1 Rotor 0	OK	16167	Spinning at normal speed
SFT 4 Fan 1 Rotor 1	OK	14555	Spinning at normal speed
SFT 4 Fan 2 Rotor 0	OK	16023	Spinning at normal speed
SFT 4 Fan 2 Rotor 1	OK	14361	Spinning at normal speed
SFT 4 Fan 3 Rotor 0	OK	16216	Spinning at normal speed
SFT 4 Fan 3 Rotor 1	OK	14438	Spinning at normal speed
SFT 5 Fan 0 Rotor 0	OK	15297	Spinning at normal speed
SFT 5 Fan 0 Rotor 1	OK	14173	Spinning at normal speed
SFT 5 Fan 1 Rotor 0	OK	15472	Spinning at normal speed
SFT 5 Fan 1 Rotor 1	OK	13846	Spinning at normal speed
SFT 5 Fan 2 Rotor 0	OK	15340	Spinning at normal speed
SFT 5 Fan 2 Rotor 1	OK	13917	Spinning at normal speed
SFT 5 Fan 3 Rotor 0	OK	15835	Spinning at normal speed
SFT 5 Fan 3 Rotor 1	OK	13917	Spinning at normal speed
SFT 6 Fan 0 Rotor 0	OK	15743	Spinning at normal speed
SFT 6 Fan 0 Rotor 1	OK	14594	Spinning at normal speed
SFT 6 Fan 1 Rotor 0	OK	16167	Spinning at normal speed
SFT 6 Fan 1 Rotor 1	OK	14634	Spinning at normal speed
SFT 6 Fan 2 Rotor 0	OK	16167	Spinning at normal speed
SFT 6 Fan 2 Rotor 1	OK	14516	Spinning at normal speed
SFT 6 Fan 3 Rotor 0	OK	16666	Spinning at normal speed
SFT 6 Fan 3 Rotor 1	OK	14438	Spinning at normal speed
SFT 7 Fan 0 Rotor 0	OK	15517	Spinning at normal speed
SFT 7 Fan 0 Rotor 1	OK	14438	Spinning at normal speed
SFT 7 Fan 1 Rotor 0	OK	15517	Spinning at normal speed
SFT 7 Fan 1 Rotor 1	OK	14361	Spinning at normal speed
SFT 7 Fan 2 Rotor 0	OK	16167	Spinning at normal speed
SFT 7 Fan 2 Rotor 1	OK	14555	Spinning at normal speed

```
SFT 7 Fan 3 Rotor 0    OK    15697  Spinning at normal speed
SFT 7 Fan 3 Rotor 1    OK    14361  Spinning at normal speed
```

show chassis fan (EX Series Switches)

```
user@host> show chassis fan
```

Item	Status	RPM	Measurement
Fan 1	OK	3477	Spinning at normal speed
Fan 2	OK	3477	Spinning at normal speed
Fan 3	OK	3479	Spinning at normal speed
Fan 4	OK	3508	Spinning at normal speed
Fan 5	OK	3517	Spinning at normal speed
Fan 6	OK	3531	Spinning at normal speed
Fan 7	OK	3439	Spinning at normal speed
Fan 8	OK	3424	Spinning at normal speed
Fan 9	OK	3413	Spinning at normal speed
Fan 10	OK	3439	Spinning at normal speed
Fan 11	OK	3446	Spinning at normal speed
Fan 12	OK	3432	Spinning at normal speed

show chassis fan (T4000 Core Router)

```
user@host> show chassis fan
```

Item	Status	RPM	Measurement
Top Left Front fan	OK	5190	Spinning at high speed
Top Left Middle fan	OK	5220	Spinning at high speed
Top Left Rear fan	OK	5190	Spinning at high speed
Top Right Front fan	OK	5160	Spinning at high speed
Top Right Middle fan	OK	5190	Spinning at high speed
Top Right Rear fan	OK	5160	Spinning at high speed
Bottom Left Front fan	OK	6030	Spinning at high speed
Bottom Left Middle fan	OK	6090	Spinning at high speed
Bottom Left Rear fan	OK	6090	Spinning at high speed
Bottom Right Front fan	OK	6030	Spinning at high speed
Bottom Right Middle fan	OK	6060	Spinning at high speed
Bottom Right Rear fan	OK	6060	Spinning at high speed
Rear Tray Top fan	OK	10000	Spinning at high speed
Rear Tray Second fan	OK	10000	Spinning at high speed

Rear Tray Third fan	OK	10000	Spinning at high speed
Rear Tray Fourth fan	OK	10000	Spinning at high speed
Rear Tray Fifth fan	OK	10000	Spinning at high speed
Rear Tray Sixth fan	OK	10000	Spinning at high speed
Rear Tray Seventh fan	OK	10000	Spinning at high speed
Rear Tray Bottom fan	OK	10000	Spinning at high speed

show chassis fan (TX Matrix Router)

```
user@host> show chassis fan
```

```
scc-re0:
```

```
-----
```

Item	Status	RPM	Measurement
Top Left Front fan	OK	3420	Spinning at normal speed
Top Left Middle fan	OK	3390	Spinning at normal speed
Top Left Rear fan	OK	3420	Spinning at normal speed
Top Right Front fan	OK	3390	Spinning at normal speed
Top Right Middle fan	OK	3420	Spinning at normal speed
Top Right Rear fan	OK	3390	Spinning at normal speed
Bottom Left Front fan	OK	3420	Spinning at normal speed
Bottom Left Middle fan	OK	3450	Spinning at normal speed
Bottom Left Rear fan	OK	3420	Spinning at normal speed
Bottom Right Front fan	OK	3420	Spinning at normal speed
Bottom Right Middle fan	OK	3420	Spinning at normal speed
Bottom Right Rear fan	OK	3420	Spinning at normal speed
Rear Tray Top fan	OK	3420	Spinning at normal speed
Rear Tray Second fan	OK	5190	Spinning at normal speed
Rear Tray Third fan	OK	5190	Spinning at normal speed
Rear Tray Fourth fan	OK	5190	Spinning at normal speed
Rear Tray Fifth fan	OK	3420	Spinning at normal speed
Rear Tray Sixth fan	OK	3420	Spinning at normal speed
Rear Tray Seventh fan	OK	3420	Spinning at normal speed
Rear Tray Bottom fan	OK	3420	Spinning at normal speed

```
lcc2-re0:
```

```
-----
```

Item	Status	RPM	Measurement
Top Left Front fan	OK	3420	Spinning at normal speed
Top Left Middle fan	OK	3420	Spinning at normal speed
Top Left Rear fan	OK	3450	Spinning at normal speed
Top Right Front fan	OK	3420	Spinning at normal speed

```

Top Right Middle fan    OK      3450   Spinning at normal speed
Top Right Rear fan     OK      3360   Spinning at normal speed
Bottom Left Front fan  OK      3420   Spinning at normal speed
Bottom Left Middle fan OK      3480   Spinning at normal speed
Bottom Left Rear fan   OK      3420   Spinning at normal speed
Bottom Right Front fan OK      3420   Spinning at normal speed
Bottom Right Middle fan OK      3390   Spinning at normal speed
Bottom Right Rear fan  OK      3420   Spinning at normal speed
Rear Tray Top fan      OK      3420   Spinning at normal speed
Rear Tray Second fan   OK      3420   Spinning at normal speed
Rear Tray Third fan    OK      3420   Spinning at normal speed
Rear Tray Fourth fan   OK      3420   Spinning at normal speed
Rear Tray Fifth fan    OK      3420   Spinning at normal speed
Rear Tray Sixth fan    OK      3420   Spinning at normal speed
Rear Tray Seventh fan  OK      3420   Spinning at normal speed
Rear Tray Bottom fan   OK      3420   Spinning at normal speed

```

show chassis fan (TX Matrix Plus Router)

```

user@host> show chassis fan
sfc0-re0:

```

```

-----
Item                Status  RPM    Measurement
Fan Tray 0 Fan 1    OK      4350   Spinning at normal speed
Fan Tray 0 Fan 2    OK      4380   Spinning at normal speed
Fan Tray 0 Fan 3    OK      4410   Spinning at normal speed
Fan Tray 0 Fan 4    OK      4380   Spinning at normal speed
Fan Tray 0 Fan 5    OK      4350   Spinning at normal speed
Fan Tray 0 Fan 6    OK      4380   Spinning at normal speed
Fan Tray 1 Fan 1    OK      4410   Spinning at normal speed
Fan Tray 1 Fan 2    OK      4380   Spinning at normal speed
Fan Tray 1 Fan 3    OK      4410   Spinning at normal speed
Fan Tray 1 Fan 4    OK      4380   Spinning at normal speed
Fan Tray 1 Fan 5    OK      4410   Spinning at normal speed
Fan Tray 1 Fan 6    OK      4410   Spinning at normal speed
Fan Tray 2 Fan 1    OK      4380   Spinning at normal speed
Fan Tray 2 Fan 2    OK      4380   Spinning at normal speed
Fan Tray 2 Fan 3    OK      4380   Spinning at normal speed
Fan Tray 2 Fan 4    OK      4410   Spinning at normal speed
Fan Tray 2 Fan 5    OK      4380   Spinning at normal speed
Fan Tray 2 Fan 6    OK      4410   Spinning at normal speed

```

Fan Tray 2 Fan 7	OK	4410	Spinning at normal speed
Fan Tray 2 Fan 8	OK	4380	Spinning at normal speed
Fan Tray 2 Fan 9	OK	4380	Spinning at normal speed
Fan Tray 3 Fan 1	OK	4350	Spinning at normal speed
Fan Tray 3 Fan 2	OK	4380	Spinning at normal speed
Fan Tray 3 Fan 3	OK	4410	Spinning at normal speed
Fan Tray 3 Fan 4	OK	4440	Spinning at normal speed
Fan Tray 3 Fan 5	OK	4380	Spinning at normal speed
Fan Tray 3 Fan 6	OK	4410	Spinning at normal speed
Fan Tray 3 Fan 7	OK	4410	Spinning at normal speed
Fan Tray 3 Fan 8	OK	4380	Spinning at normal speed
Fan Tray 3 Fan 9	OK	4410	Spinning at normal speed
Fan Tray 4 Fan 1	OK	4410	Spinning at normal speed
Fan Tray 4 Fan 2	OK	4410	Spinning at normal speed
Fan Tray 4 Fan 3	OK	4380	Spinning at normal speed
Fan Tray 4 Fan 4	OK	4380	Spinning at normal speed
Fan Tray 4 Fan 5	OK	4410	Spinning at normal speed
Fan Tray 4 Fan 6	OK	4410	Spinning at normal speed
Fan Tray 4 Fan 7	OK	4410	Spinning at normal speed
Fan Tray 4 Fan 8	OK	4410	Spinning at normal speed
Fan Tray 4 Fan 9	OK	4410	Spinning at normal speed
Fan Tray 5 Fan 1	OK	4350	Spinning at normal speed
Fan Tray 5 Fan 2	OK	4380	Spinning at normal speed
Fan Tray 5 Fan 3	OK	4380	Spinning at normal speed
Fan Tray 5 Fan 4	OK	4350	Spinning at normal speed
Fan Tray 5 Fan 5	OK	4380	Spinning at normal speed
Fan Tray 5 Fan 6	OK	4410	Spinning at normal speed
Fan Tray 5 Fan 7	OK	4410	Spinning at normal speed
Fan Tray 5 Fan 8	OK	4380	Spinning at normal speed
Fan Tray 5 Fan 9	OK	4410	Spinning at normal speed

lcc0-re0:

Item	Status	RPM	Measurement
Top Left Front fan	OK	3420	Spinning at normal speed
Top Left Middle fan	OK	3420	Spinning at normal speed
Top Left Rear fan	OK	3420	Spinning at normal speed
Top Right Front fan	OK	3450	Spinning at normal speed
Top Right Middle fan	OK	3420	Spinning at normal speed
Top Right Rear fan	OK	3420	Spinning at normal speed
Bottom Left Front fan	OK	3420	Spinning at normal speed
Bottom Left Middle fan	OK	3420	Spinning at normal speed
Bottom Left Rear fan	OK	3390	Spinning at normal speed

Bottom Right Front fan	OK	3420	Spinning at normal speed
Bottom Right Middle fan	OK	3390	Spinning at normal speed
Bottom Right Rear fan	OK	3390	Spinning at normal speed
Rear Tray Top fan	OK	7050	Spinning at normal speed
Rear Tray Second fan	OK	7050	Spinning at normal speed
Rear Tray Third fan	OK	7050	Spinning at normal speed
Rear Tray Fourth fan	OK	7050	Spinning at normal speed
Rear Tray Fifth fan	OK	7050	Spinning at normal speed
Rear Tray Sixth fan	OK	7050	Spinning at normal speed
Rear Tray Seventh fan	OK	7050	Spinning at normal speed
Rear Tray Bottom fan	OK	7050	Spinning at normal speed

show chassis fan (TX Matrix Plus Router with 3D SIBs)

```
user@host> show chassis fan
sfc0-re0:
```

```
-----
```

Item	Status	RPM	Measurement
Fan Tray 0 Fan 1	OK	4830	Spinning at normal speed
Fan Tray 0 Fan 2	OK	4860	Spinning at normal speed
Fan Tray 0 Fan 3	OK	4830	Spinning at normal speed
Fan Tray 0 Fan 4	OK	4800	Spinning at normal speed
Fan Tray 0 Fan 5	OK	4830	Spinning at normal speed
Fan Tray 0 Fan 6	OK	4770	Spinning at normal speed
Fan Tray 1 Fan 1	OK	4800	Spinning at normal speed
Fan Tray 1 Fan 2	OK	4770	Spinning at normal speed
Fan Tray 1 Fan 3	OK	4800	Spinning at normal speed
Fan Tray 1 Fan 4	OK	4770	Spinning at normal speed
Fan Tray 1 Fan 5	OK	4770	Spinning at normal speed
Fan Tray 1 Fan 6	OK	4800	Spinning at normal speed
Fan Tray 2 Fan 1	OK	4800	Spinning at normal speed
Fan Tray 2 Fan 2	OK	4800	Spinning at normal speed
Fan Tray 2 Fan 3	OK	4830	Spinning at normal speed
Fan Tray 2 Fan 4	OK	4830	Spinning at normal speed
Fan Tray 2 Fan 5	OK	4830	Spinning at normal speed
Fan Tray 2 Fan 6	OK	4830	Spinning at normal speed
Fan Tray 2 Fan 7	OK	4800	Spinning at normal speed
Fan Tray 2 Fan 8	OK	4830	Spinning at normal speed
Fan Tray 2 Fan 9	OK	4800	Spinning at normal speed
Fan Tray 3 Fan 1	OK	4860	Spinning at normal speed
Fan Tray 3 Fan 2	OK	4860	Spinning at normal speed

Fan Tray 3 Fan 3	OK	4800	Spinning at normal speed
Fan Tray 3 Fan 4	OK	4830	Spinning at normal speed
Fan Tray 3 Fan 5	OK	4830	Spinning at normal speed
Fan Tray 3 Fan 6	OK	4830	Spinning at normal speed
Fan Tray 3 Fan 7	OK	4830	Spinning at normal speed
Fan Tray 3 Fan 8	OK	4800	Spinning at normal speed
Fan Tray 3 Fan 9	OK	4800	Spinning at normal speed
Fan Tray 4 Fan 1	OK	4830	Spinning at normal speed
Fan Tray 4 Fan 2	OK	4830	Spinning at normal speed
Fan Tray 4 Fan 3	OK	4830	Spinning at normal speed
Fan Tray 4 Fan 4	OK	4830	Spinning at normal speed
Fan Tray 4 Fan 5	OK	4830	Spinning at normal speed
Fan Tray 4 Fan 6	OK	4860	Spinning at normal speed
Fan Tray 4 Fan 7	OK	4800	Spinning at normal speed
Fan Tray 4 Fan 8	OK	4860	Spinning at normal speed
Fan Tray 4 Fan 9	OK	4770	Spinning at normal speed
Fan Tray 5 Fan 1	OK	4830	Spinning at normal speed
Fan Tray 5 Fan 2	OK	4830	Spinning at normal speed
Fan Tray 5 Fan 3	OK	4830	Spinning at normal speed
Fan Tray 5 Fan 4	OK	4800	Spinning at normal speed
Fan Tray 5 Fan 5	OK	4800	Spinning at normal speed
Fan Tray 5 Fan 6	OK	4800	Spinning at normal speed
Fan Tray 5 Fan 7	OK	4830	Spinning at normal speed
Fan Tray 5 Fan 8	OK	4830	Spinning at normal speed
Fan Tray 5 Fan 9	Check	2010	

lcc0-re0:

Item	Status	RPM	Measurement
Top Left Front fan	OK	3420	Spinning at normal speed
Top Left Middle fan	OK	3390	Spinning at normal speed
Top Left Rear fan	OK	3390	Spinning at normal speed
Top Right Front fan	OK	3420	Spinning at normal speed
Top Right Middle fan	OK	3420	Spinning at normal speed
Top Right Rear fan	OK	3450	Spinning at normal speed
Bottom Left Front fan	OK	3420	Spinning at normal speed
Bottom Left Middle fan	OK	3390	Spinning at normal speed
Bottom Left Rear fan	OK	3420	Spinning at normal speed
Bottom Right Front fan	OK	3420	Spinning at normal speed
Bottom Right Middle fan	OK	3390	Spinning at normal speed
Bottom Right Rear fan	OK	3420	Spinning at normal speed
Rear Tray fan 1 (Top)	OK	7740	Spinning at normal speed
Rear Tray fan 2	OK	7740	Spinning at normal speed

Rear Tray fan 3	OK	7740	Spinning at normal speed
Rear Tray fan 4	OK	7740	Spinning at normal speed
Rear Tray fan 5	OK	7740	Spinning at normal speed
Rear Tray fan 6	OK	7740	Spinning at normal speed
Rear Tray fan 7	OK	7740	Spinning at normal speed
Rear Tray fan 8	OK	7740	Spinning at normal speed
Rear Tray fan 9	OK	7740	Spinning at normal speed
Rear Tray fan 10	OK	7740	Spinning at normal speed
Rear Tray fan 11	OK	7740	Spinning at normal speed
Rear Tray fan 12	OK	7740	Spinning at normal speed
Rear Tray fan 13	OK	7740	Spinning at normal speed
Rear Tray fan 14	OK	7740	Spinning at normal speed
Rear Tray fan 15	OK	7740	Spinning at normal speed
Rear Tray fan 16 (Bottom)	OK	7740	Spinning at normal speed

lcc2-re0:

Item	Status	RPM	Measurement
Top Left Front fan	OK	3420	Spinning at normal speed
Top Left Middle fan	OK	3390	Spinning at normal speed
Top Left Rear fan	OK	3420	Spinning at normal speed
Top Right Front fan	OK	3420	Spinning at normal speed
Top Right Middle fan	OK	3420	Spinning at normal speed
Top Right Rear fan	OK	3450	Spinning at normal speed
Bottom Left Front fan	OK	3420	Spinning at normal speed
Bottom Left Middle fan	OK	3390	Spinning at normal speed
Bottom Left Rear fan	OK	3420	Spinning at normal speed
Bottom Right Front fan	OK	3420	Spinning at normal speed
Bottom Right Middle fan	OK	3390	Spinning at normal speed
Bottom Right Rear fan	OK	3420	Spinning at normal speed
Rear Tray fan 1 (Top)	OK	7740	Spinning at normal speed
Rear Tray fan 2	OK	7740	Spinning at normal speed
Rear Tray fan 3	OK	7740	Spinning at normal speed
Rear Tray fan 4	OK	7740	Spinning at normal speed
Rear Tray fan 5	OK	7740	Spinning at normal speed
Rear Tray fan 6	OK	7740	Spinning at normal speed
Rear Tray fan 7	OK	7740	Spinning at normal speed
Rear Tray fan 8	OK	7740	Spinning at normal speed
Rear Tray fan 9	OK	7740	Spinning at normal speed
Rear Tray fan 10	OK	7740	Spinning at normal speed
Rear Tray fan 11	OK	7740	Spinning at normal speed
Rear Tray fan 12	OK	7740	Spinning at normal speed
Rear Tray fan 13	OK	7740	Spinning at normal speed

Rear Tray fan 14	OK	7740	Spinning at normal speed
Rear Tray fan 15	OK	7740	Spinning at normal speed
Rear Tray fan 16 (Bottom)	OK	7740	Spinning at normal speed

show chassis fan (PTX5000 Packet Transport Router)

```

user@host> show chassis fan
user@host> show chassis fan

```

Item	Status	% RPM	Measurement
Fan Tray 0 Fan 1	OK	29%	2700 RPM
Fan Tray 0 Fan 2	OK	29%	2700 RPM
Fan Tray 0 Fan 3	OK	29%	2742 RPM
Fan Tray 0 Fan 4	OK	29%	2700 RPM
Fan Tray 0 Fan 5	OK	30%	2828 RPM
Fan Tray 0 Fan 6	OK	30%	2828 RPM
Fan Tray 0 Fan 7	OK	29%	2700 RPM
Fan Tray 0 Fan 8	OK	30%	2785 RPM
Fan Tray 0 Fan 9	OK	30%	2828 RPM
Fan Tray 0 Fan 10	OK	30%	2828 RPM
Fan Tray 0 Fan 11	OK	30%	2785 RPM
Fan Tray 0 Fan 12	OK	30%	2828 RPM
Fan Tray 0 Fan 13	OK	31%	2871 RPM
Fan Tray 0 Fan 14	OK	30%	2828 RPM
Fan Tray 1 Fan 1	OK	42%	3033 RPM
Fan Tray 1 Fan 2	OK	42%	3066 RPM
Fan Tray 1 Fan 3	OK	43%	3099 RPM
Fan Tray 1 Fan 4	OK	43%	3166 RPM
Fan Tray 1 Fan 5	OK	45%	3266 RPM
Fan Tray 1 Fan 6	OK	43%	3133 RPM
Fan Tray 2 Fan 1	OK	29%	2099 RPM
Fan Tray 2 Fan 2	OK	30%	2199 RPM
Fan Tray 2 Fan 3	OK	30%	2166 RPM
Fan Tray 2 Fan 4	OK	33%	2399 RPM
Fan Tray 2 Fan 5	OK	29%	2133 RPM
Fan Tray 2 Fan 6	OK	32%	2366 RPM

show chassis fan (MX150)

```

user@host > show chassis fan

```

Item	Status	RPM	Measurement
------	--------	-----	-------------

```
FPC 0 Tray 0 Fan 0      OK      7419   Spinning at normal speed
FPC 0 Tray 1 Fan 0      OK      7419   Spinning at normal speed
```

show chassis fan (MX104 Router)

```
user@host > show chassis fan
```

Item	Status	RPM	Measurement
Fan 1	OK	5640	Spinning at normal speed
Fan 2	OK	5640	Spinning at normal speed
Fan 3	OK	5760	Spinning at normal speed
Fan 4	OK	5640	Spinning at normal speed
Fan 5	OK	5640	Spinning at normal speed

show chassis fan (MX2010 Router)

```
user@host > show chassis fan
```

Item	Status	% RPM	Measurement
Fan Tray 0 Fan 1	OK	37%	3360 RPM
Fan Tray 0 Fan 2	OK	38%	3480 RPM
Fan Tray 0 Fan 3	OK	37%	3360 RPM
Fan Tray 0 Fan 4	OK	37%	3360 RPM
Fan Tray 0 Fan 5	OK	38%	3480 RPM
Fan Tray 0 Fan 6	OK	37%	3360 RPM
Fan Tray 1 Fan 1	OK	38%	3480 RPM
Fan Tray 1 Fan 2	OK	40%	3600 RPM
Fan Tray 1 Fan 3	OK	38%	3480 RPM
Fan Tray 1 Fan 4	OK	38%	3480 RPM
Fan Tray 1 Fan 5	OK	38%	3480 RPM
Fan Tray 1 Fan 6	OK	38%	3480 RPM
Fan Tray 2 Fan 1	OK	38%	3480 RPM
Fan Tray 2 Fan 2	OK	41%	3720 RPM
Fan Tray 2 Fan 3	OK	38%	3480 RPM
Fan Tray 2 Fan 4	OK	38%	3480 RPM
Fan Tray 2 Fan 5	OK	38%	3480 RPM
Fan Tray 2 Fan 6	OK	38%	3480 RPM
Fan Tray 3 Fan 1	OK	38%	3480 RPM
Fan Tray 3 Fan 2	OK	40%	3600 RPM
Fan Tray 3 Fan 3	OK	40%	3600 RPM
Fan Tray 3 Fan 4	OK	40%	3600 RPM

Fan Tray 3 Fan 5	OK	40%	3600 RPM
Fan Tray 3 Fan 6	OK	38%	3480 RPM

show chassis fan (ACX4000 Router)

```
user@host > show chassis fan
```

Item	Status	RPM	Measurement
Fan 1	OK	4140	Spinning at normal speed
Fan 2	OK	4200	Spinning at normal speed

show chassis fan (ACX5048 Router)

```
user@host > show chassis fan
```

Item	Status	RPM	Measurement
FPC 0 Tray 0 Fan 0	OK	18305	Spinning at normal speed
FPC 0 Tray 0 Fan 1	OK	15743	Spinning at normal speed
FPC 0 Tray 1 Fan 0	OK	18305	Spinning at normal speed
FPC 0 Tray 1 Fan 1	OK	15606	Spinning at normal speed
FPC 0 Tray 2 Fan 0	OK	19014	Spinning at normal speed
FPC 0 Tray 2 Fan 1	OK	16167	Spinning at normal speed
FPC 0 Tray 3 Fan 0	OK	18947	Spinning at normal speed
FPC 0 Tray 3 Fan 1	OK	16265	Spinning at normal speed
FPC 0 Tray 4 Fan 0	OK	18120	Spinning at normal speed
FPC 0 Tray 4 Fan 1	OK	15743	Spinning at normal speed

show chassis fan (QFX5100 Switch and OCX Series)

```
user@switch > show chassis fan
```

Item	Status	RPM	Measurement
FPC 0 Tray 0 Fan 0	OK	6428	Spinning at normal speed
FPC 0 Tray 0 Fan 1	OK	5515	Spinning at normal speed
FPC 0 Tray 1 Fan 0	OK	6360	Spinning at normal speed
FPC 0 Tray 1 Fan 1	OK	5532	Spinning at normal speed

show chassis fan (EX9251 switches)

```
user@switch > show chassis fan
```

Item	Status	% RPM	Measurement
Fan Tray 0 Fan 0	OK	40%	9600 RPM
Fan Tray 0 Fan 1	OK	40%	8832 RPM
Fan Tray 1 Fan 0	OK	40%	9728 RPM
Fan Tray 1 Fan 1	OK	40%	9088 RPM
Fan Tray 2	Absent		

show chassis fan (EX9253 switches)

```
user@switch > show chassis fan
```

Item	Status	% RPM	Measurement
Fan Tray 0 Fan 0	OK	40%	7552 RPM
Fan Tray 0 Fan 1	OK	40%	6272 RPM
Fan Tray 0 Fan 2	OK	40%	7552 RPM
Fan Tray 0 Fan 3	OK	40%	6272 RPM
Fan Tray 1 Fan 0	OK	40%	7552 RPM
Fan Tray 1 Fan 1	OK	40%	6272 RPM
Fan Tray 1 Fan 2	OK	40%	7552 RPM
Fan Tray 1 Fan 3	OK	40%	6272 RPM
Fan Tray 2 Fan 0	OK	40%	7552 RPM
Fan Tray 2 Fan 1	OK	40%	6400 RPM
Fan Tray 2 Fan 2	OK	40%	7552 RPM
Fan Tray 2 Fan 3	OK	40%	6272 RPM
Fan Tray 3 Fan 0	OK	40%	7552 RPM
Fan Tray 3 Fan 1	OK	40%	6400 RPM
Fan Tray 3 Fan 2	OK	40%	7552 RPM
Fan Tray 3 Fan 3	OK	40%	6272 RPM

show chassis fan (Junos OS Evolved)

```
user@device> show chassis fan
```

Item	Status	% RPM	Measurement
Fan Tray 1 Fan 1	Ok	48%	6597 RPM
Fan Tray 1 Fan 2	Ok	49%	5649 RPM

Fan Tray 2 Fan 1	Ok	49%	6687 RPM
Fan Tray 2 Fan 2	Ok	49%	5649 RPM
Fan Tray 3 Fan 1	Ok	49%	6642 RPM
Fan Tray 3 Fan 2	Ok	49%	5649 RPM

Release Information

Command introduced in Junos OS Release 10.0 on MX Series 5G Universal Routing Platforms, M120 routers, and M320 routers, T320 routers, T640 routers, T1600 routers, TX Matrix Routers, and TX Matrix Plus routers.

satellite option introduced in Junos OS Release 14.2R3.

Command output introduced for Junos OS Evolved Release 19.1R1.

show chassis firmware

IN THIS SECTION

- [Syntax | 530](#)
- [Syntax \(TX Matrix Routers\) | 530](#)
- [Syntax \(TX Matrix Plus Routers\) | 530](#)
- [Syntax \(MX Series Routers\) | 530](#)
- [Syntax \(MX104, MX204, MX2010, MX2020, MX10003, and MX2008 Universal Routing Platforms\) | 530](#)
- [Syntax \(QFX Series\) | 530](#)
- [Syntax \(ACX5048 and ACX5096 Routers\) | 531](#)
- [Syntax \(EX Series Switches\) | 531](#)
- [Description | 531](#)
- [Options | 531](#)
- [Required Privilege Level | 533](#)
- [Output Fields | 533](#)
- [Sample Output | 534](#)
- [Release Information | 549](#)

Syntax

```
show chassis firmware
```

Syntax (TX Matrix Routers)

```
show chassis firmware  
<lcc number | scc>
```

Syntax (TX Matrix Plus Routers)

```
show chassis firmware  
<lcc number | sfc number>
```

Syntax (MX Series Routers)

```
show chassis firmware  
<all-members>  
<local>  
<member member-id>
```

Syntax (MX104, MX204, MX2010, MX2020, MX10003, and MX2008 Universal Routing Platforms)

```
show chassis firmware  
<satellite [slot-id slot-id |device-alias alias-name]>
```

Syntax (QFX Series)

```
show chassis firmware  
interconnect-device name  
node-device name
```

Syntax (ACX5048 and ACX5096 Routers)

```
show chassis firmware
interconnect-device name
node-device name
```

Syntax (EX Series Switches)

```
show chassis firmware
<detail>
<satellite [slot-id slot-id |device-alias alias-name]>
```

Description

On routers and switches, display the version levels of the firmware running on the System Control Board (SCB), Switching and Forwarding Module (SFM), System and Switch Board (SSB), Forwarding Engine Board (FEB), Flexible PIC Concentrators (FPCs), and Routing Engines. On a TX Matrix Plus router, display the version levels of the firmware running on the FPCs and the Switch Processor Mezzanine Board (SPMBs).

On EX2200, EX3200, EX4200, QFX Series, and OCX Series switches, display the version levels of the firmware running on the switch. On an EX8208 switch, display the version levels of the firmware running on the Switch Fabric and Routing Engine (SRE) modules and on the line cards (shown as FPCs). On an EX8216 switch, display the version levels of the firmware running on the Routing Engine (RE) modules and on the line cards (shown as FPCs).

Options

- | | |
|--------------------|---|
| none | Display the version levels of the firmware running. For an EX4200 switch that is a member of a Virtual Chassis, display version levels for all members. For a TX Matrix router, display version levels for the firmware on the TX Matrix router and on all the T640 routers connected to the TX Matrix router. For a TX Matrix Plus router, display version levels for the firmware on the TX Matrix Plus router and on all the routers connected to the TX Matrix Plus router. |
| all-members | (MX Series routers only) (Optional) Display the version levels of the firmware running for all members of the Virtual Chassis configuration. |

interconnect-device <i>name</i>	(QFabric systems) (Optional) Display the version levels of the firmware running on the Interconnect device.
lcc <i>number</i>	<p>(TX Matrix and TX Matrix Plus routers only) (Optional) On a TX Matrix router, display version levels for the firmware on a specified T640 router (line-card chassis) that is connected to the TX Matrix router. On a TX Matrix Plus router, display the version levels for the firmware on a specified router (line-card chassis) that is connected to the TX Matrix Plus router.</p> <p>Replace <i>number</i> with the following values depending on the LCC configuration:</p> <ul style="list-style-type: none"> • 0 through 3, when T640 routers are connected to a TX Matrix router in a routing matrix. • 0 through 3, when T1600 routers are connected to a TX Matrix Plus router in a routing matrix. • 0 through 7, when T1600 routers are connected to a TX Matrix Plus router with 3D SIBs in a routing matrix. • 0, 2, 4, or 6, when T4000 routers are connected to a TX Matrix Plus router with 3D SIBs in a routing matrix.
local	(MX Series routers only) (Optional) Display the version levels of the firmware running for the local Virtual Chassis member.
member <i>member-id</i>	(MX Series routers only) (Optional) Display the version levels of the firmware running for the specified member of the Virtual Chassis configuration. Replace <i>member-id</i> with a value of 0 or 1.
node-device	(QFabric systems only) (Optional) Display the version levels of the firmware running on the Node device.
satellite [slot-id slot-id] device-alias <i>alias-name</i>	(Junos Fusion only) (Optional) Display version levels of the firmware running for the specified satellite device or devices in a Junos Fusion, or for all satellite devices if no satellite devices are specified.
scc	(TX Matrix router only) (Optional) Display version levels for the firmware on the TX Matrix router (switch-card chassis).
sfc <i>number</i>	(TX Matrix Plus router only) (Optional) Display version levels for the firmware on the TX Matrix Plus router (or switch-fabric chassis). Replace <i>number</i> with 0.

detail (EX3200, EX3300, EX4200, and EX4500 standalone and Virtual Chassis member switches only) (Optional) Display version levels of the firmware running on the switch for its programmable hardware components.

Required Privilege Level

view

Output Fields

Table 19 on page 533 lists the output fields for the show chassis firmware command. Output fields are listed in the approximate order in which they appear.

Table 19: show chassis firmware Output Fields

Field Name	Field Description
Part	(MX Series, MX2010, MX2020, and MX2008 routers) Chassis part name.
Type	(MX Series, MX2010, MX2020, and MX2008 routers) Type of firmware: On routers: ROM or O/S. On switches: uboot or loader.
Version	(MX Series, MX2010, MX2020, and MX2008 routers) Version of firmware running on the chassis part.
FPC	(<i>detail</i> option only) Number of FPC. For a standalone switch, the value is 0. For a Virtual Chassis configuration, value in the range of 0-9; refers to the member ID assigned to the switch.
AFEB	(MX104 routers) Version of the compact Forwarding Engine Board.
Boot	(<i>detail</i> option only) Version of the SYSPLD.
PoE	(<i>detail</i> option only) Version of the PoE firmware.

Table 19: show chassis firmware Output Fields (Continued)

Field Name	Field Description
PFE- <number>	(<i>detail</i> option only) Version of the Packet Forwarding Engine used in the switch.
PHY-	(<i>detail</i> option only) Version of the physical layer device (PHY) used in the switch.
microcode	(<i>detail</i> option only) Microcode of the physical layer devices (PHY) used in the switch.
uboot	(<i>detail</i> option only) Version of the u-boot used in the switch.
loader	(<i>detail</i> option only) Version of the loader used in the switch.

Sample Output

show chassis firmware (M10 Router)

```

user@host> show chassis firmware
Part                Type      Version
Forwarding engine board ROM        Juniper ROM Monitor Version 4.1b2
                   O/S        Version 4.1I1 by usera on 2000-04-24 11:27

```

show chassis firmware (M20 Router)

```

user@host> show chassis firmware
Part                Type      Version
System switch board ROM        Juniper ROM Monitor Version 3.4b26
                   O/S        Version 3.4I16 by userc on 2000-02-29 2
FPC 1               ROM        Juniper ROM Monitor Version 3.0b1
                   O/S        Version 3.4I4 by userc on 2000-02-25 21
FPC 2               ROM        Juniper ROM Monitor Version 3.0b1
                   O/S        Version 3.4I4 by userc on 2000-02-25 21

```

show chassis firmware (M40 Router)

```

user@host> show chassis firmware
Part                Type      Version
System control board ROM       Juniper ROM Monitor Version 2.0i126Copyri
                   O/S      Version 2.0i1 by root on Thu Jul 23 00:51
FPC 5               ROM       Juniper ROM Monitor Version 2.0i49Copyrig
                   O/S      Version 2.0i1 by root on Thu Jul 23 00:59

```

show chassis firmware (M160 Router)

```

user@host> show chassis firmware
Part                Type      Version
SFM 0               ROM       Juniper ROM Monitor Version 4.0b2
                   O/S      Version 4.0I1 by usera on 2000-02-29 11:50
SFM 1               ROM       Juniper ROM Monitor Version 4.0b2
                   O/S      Version 4.0I1 by usera on 2000-02-29 11:50
FPC 0               ROM       Juniper ROM Monitor Version 4.0b2
                   O/S      Version 4.0I1 by usera on 2000-02-29 11:56
FPC 1               ROM       Juniper ROM Monitor Version 4.0b2
                   O/S      Version 4.0I1 by usera on 2000-02-29 11:56
FPC 2               ROM       Juniper ROM Monitor Version 4.0b3
                   O/S      Version 4.0I1 by usera on 2000-02-29 11:56

```

show chassis firmware (MX150)

```

user@host > show chassis firmware
Part                Type      Version
FPC                 ROM       PC Bios
                   O/S      Version 17.2I20170220_0929_rohitn by rohitn on 2017-02-20
09:38:59 UTC

```

show chassis firmware (MX104 Router)

```

user@host > show chassis firmware
Part                Type      Version
FPC 0               ROM       Juniper ROM Monitor Version 13.1b24

```

FPC 1	O/S	Version 13.2-20130514.1 by userb on 2013-
	ROM	Juniper ROM Monitor Version 13.1b24
FPC 2	O/S	Version 13.2-20130514.1 by userb on 2013-
	ROM	Juniper ROM Monitor Version 13.1b24
AFEB	O/S	Version 13.2-20130514.1 by userb on 2013-
	ROM	Juniper ROM Monitor Version 13.1b24
	O/S	Version 13.2-20130514.1 by userb on 2013-

show chassis firmware (MX240 Router)

```
user@host> show chassis firmware
```

Part	Type	Version
FPC 1	ROM	Juniper ROM Monitor Version 8.3b1
	O/S	Version 9.0-20080103.0 by userb on 2008-0
FPC 2	ROM	Juniper ROM Monitor Version 8.3b1
	O/S	Version 9.0-20080103.0 by userb on 2008-0

show chassis firmware (MX480 Router)

```
user@host> show chassis firmware
```

Part	Type	Version
FPC 1	ROM	Juniper ROM Monitor Version 8.3b1
	O/S	Version 9.0-20070916.3 by userb on 2007-0

show chassis firmware (MX960 Router)

```
user@host> show chassis firmware
```

Part	Type	Version
FPC 4	ROM	Juniper ROM Monitor Version 8.0b8
	O/S	Version 8.2I59 by user3 on 2006-10-31 19:22
FPC 7	ROM	Juniper ROM Monitor Version 8.2b1
	O/S	Version 8.2-20061026.1 by userb on 2006-1

show chassis firmware (MX2020 Router)

```

user@host> show chassis firmware
Part          Type      Version
FPC 0         ROM       Juniper ROM Monitor Version 10.0b39
              O/S       Version 12.3-20130415.0 by userb on 2013-
FPC 1         ROM       Juniper ROM Monitor Version 10.0b39
              O/S       Version 12.3-20130415.0 by userb on 2013-
FPC 2         ROM       Juniper ROM Monitor Version 10.0b39
              O/S       Version 12.3-20130415.0 by userb on 2013-
FPC 3         ROM       Juniper ROM Monitor Version 10.0b39
              O/S       Version 12.3-20130415.0 by userb on 2013-
FPC 4         ROM       Juniper ROM Monitor Version 10.0b39
              O/S       Version 12.3-20130415.0 by userb on 2013-
FPC 5         ROM       Juniper ROM Monitor Version 10.0b39
              O/S       Version 12.3-20130415.0 by userb on 2013-
FPC 6         ROM       Juniper ROM Monitor Version 10.0b39
              O/S       Version 12.3-20130415.0 by userb on 2013-
FPC 7         ROM       Juniper ROM Monitor Version 10.0b39
              O/S       Version 12.3-20130415.0 by userb on 2013-
FPC 8         ROM       Juniper ROM Monitor Version 10.0b39
              O/S       Version 12.3-20130415.0 by userb on 2013-
FPC 9         ROM       Juniper ROM Monitor Version 10.0b39
              O/S       Version 12.3-20130415.0 by userb on 2013-
FPC 10        ROM       Juniper ROM Monitor Version 10.0b39
              O/S       Version 12.3-20130415.0 by userb on 2013-
FPC 11        ROM       Juniper ROM Monitor Version 10.0b39
              O/S       Version 12.3-20130415.0 by userb on 2013-
FPC 12        ROM       Juniper ROM Monitor Version 10.0b39
              O/S       Version 12.3-20130415.0 by userb on 2013-
FPC 13        ROM       Juniper ROM Monitor Version 10.0b39
              O/S       Version 12.3-20130415.0 by userb on 2013-
FPC 14        ROM       Juniper ROM Monitor Version 10.0b39
              O/S       Version 12.3-20130415.0 by userb on 2013-
FPC 15        ROM       Juniper ROM Monitor Version 10.0b39
              O/S       Version 12.3-20130415.0 by userb on 2013-
FPC 16        ROM       Juniper ROM Monitor Version 10.0b39
              O/S       Version 12.3-20130415.0 by userb on 2013-
FPC 17        ROM       Juniper ROM Monitor Version 10.0b39
              O/S       Version 12.3-20130415.0 by userb on 2013-
FPC 18        ROM       Juniper ROM Monitor Version 10.0b39
              O/S       Version 12.3-20130415.0 by userb on 2013-

```

FPC 19	ROM	Juniper ROM Monitor Version 10.0b39
	O/S	Version 12.3-20130415.0 by userb on 2013-
SPMB 0	ROM	Juniper ROM Monitor Version 12.1b1
	O/S	Version 12.3-20130415.0 by userb on 2013-
SPMB 1	ROM	Juniper ROM Monitor Version 12.1b1
	O/S	Version 12.3-20130415.0 by userb on 2013-

show chassis firmware (MX204 Router)

```
user@host> show chassis firmware
```

Part	Type	Version
RE 0	PRI BIOS	CBEP_P_SUM1_00.11.01
	RE-FPGA	300
FPC	ROM	PC Bios
	O/S	Version 17.4I20171105_0609_aahluwalia by aahluwalia on
2017-11-05 06:09:28 UTC		

show chassis firmware (MX10008 Router)

```
user@host> show chassis firmware
```

Part	Type	Version
RE 0	PRI BIOS	CBEP_P_VAL0_00.14.1
	FPGA	264.0
	RE-FPGA	41.0
	RE-SSD1	SF-SBR12050
	RE-SSD2	SF-SBR12050
	i40e-NVM	6.01
RE 1	PRI BIOS	CBEP_P_VAL0_00.13.01
	FPGA	261.0
	RE-FPGA	41.0
	RE-SSD1	SF-SBR12034
	RE-SSD2	SF-SBR12034
	i40e-NVM	5.02
FPC 0	ROM	PC Bios
	O/S	Version 18.4-20180716_dev_common.0 by builder on 2018-07-16
00:43:35 UTC		
	ROM Monitor 0	9.14.0
	PCIE Sw(0)	1.0.0
	MPCS(0)	0.2.0

```

I2CS CPLD 0.4.0
BOOT CPLD 0.4.0
FPC 2      ROM      PC Bios
           O/S      Version 18.4-20180716_dev_common.0 by builder on 2018-07-16
00:43:35 UTC

           ROM Monitor 0 9.14.0
           PCIE Sw(0) 1.0.0
           MPCS(0) 0.2.0
           I2CS CPLD 0.4.0
           BOOT CPLD 0.4.0
FPC 3      ROM      PC Bios
           O/S      Version 18.4-20180716_dev_common.0 by builder on 2018-07-16
00:43:35 UTC

           ROM Monitor 0 9.14.0
           PCIE Sw(0) 1.0.0
           MPCS(0) 0.4.0
           I2CS CPLD 0.8.0
           BOOT CPLD 0.8.0
FPM        FPGA     1.9
FTC 0      FPGA     2.0
FTC 1      FPGA     2.0
SFB 0      FPGA     3.0
SFB 1      FPGA     3.0
SFB 2      FPGA     3.0
SFB 3      FPGA     3.0
SFB 4      FPGA     3.0
SFB 5      FPGA     3.0

```

show chassis firmware (MX240, MX480, MX960 Router with Application Services Modular Line Card)

```
user@host> show chassis firmware
```

```

Part          Type      Version
FPC 1         ROM      Juniper ROM Monitor Version 12.1b1
              O/S      Version 12.2I21 by user1 on 2012-06-19 17:

```

show chassis firmware (EX4200 Switch)

```
user@switch> show chassis firmware
```

Part	Type	Version
FPC 0	uboot	U-Boot 1.1.6 (Feb 6 2008 - 11:27:42)
	loader	FreeBSD/PowerPC U-Boot bootstrap loader 2.1
FPC 1	uboot	U-Boot 1.1.6 (Feb 6 2008 - 11:27:42)
	loader	FreeBSD/PowerPC U-Boot bootstrap loader 2.1
FPC 2	uboot	U-Boot 1.1.6 (Feb 6 2008 - 11:27:42)
	loader	FreeBSD/PowerPC U-Boot bootstrap loader 2.1

show chassis firmware (EX8200 Switch)

```
user@switch> show chassis firmware
```

Part	Type	Version
FPC 0	U-Boot	U-Boot 1.1.6 (Mar 25 2009 - 06:13:12) 2.4.0
	loader	FreeBSD/PowerPC U-Boot bootstrap loader 2.2
FPC 3	U-Boot	U-Boot 1.1.6 (Dec 4 2009 - 13:17:34) 3.1.0
	loader	FreeBSD/PowerPC U-Boot bootstrap loader 2.2
FPC 5	U-Boot	U-Boot 1.1.6 (Mar 25 2009 - 06:13:12) 2.4.0
	loader	FreeBSD/PowerPC U-Boot bootstrap loader 2.2
FPC 7	U-Boot	U-Boot 1.1.6 (Feb 6 2009 - 05:31:46) 2.4.0
	loader	FreeBSD/PowerPC U-Boot bootstrap loader 2.2
Routing Engine 0	U-Boot	U-Boot 1.1.6 (Mar 25 2009 - 06:13:12) 2.4.0
	loader	FreeBSD/PowerPC U-Boot bootstrap loader 2.2
Routing Engine 1	U-Boot	U-Boot 1.1.6 (Mar 25 2009 - 06:13:12) 2.4.0
	loader	FreeBSD/PowerPC U-Boot bootstrap loader 2.2

show chassis firmware (EX9200 Switch)

```
user@switch> show chassis firmware
```

Part	Type	Version
FPC 2	ROM	Juniper ROM Monitor Version 11.4b2
	O/S	Version 14.1I20140312_0741 by userd o

```
FPC 3          ROM      Juniper ROM Monitor Version 10.4b1
                O/S      Version 14.1I20140312_0741 by userd o
```

show chassis firmware (EX9251 Switch)

```
user@switch> show chassis firmware
```

```
Part          Type      Version
RE 0          PRI BIOS  CBEP_P_SUM1_00.11.01
              RE-FPGA  301
FPC           ROM      PC Bios
              O/S      Version 18.1R1.4 by builder on 2018-03-06 00:31:54 UTC
```

show chassis firmware (EX9253 Switch)

```
user@switch> show chassis firmware
```

```
Part          Type      Version
RE 0          PRI BIOS  CBEP_P_SUM1_00.11.01
              RE-FPGA  402
RE 1          PRI BIOS  CBEP_P_SUM1_00.11.01
              RE-FPGA  402
FPC 0         ROM      PC Bios
              O/S      Version 18.2-20180129_dev_common.1 by builder on 2018-01-29
13:35:11 UTC
FPC 1         ROM      PC Bios
              O/S      Version 18.2-20180129_dev_common.1 by builder on 2018-01-29
13:35:11 UTC
```

show chassis firmware lcc (TX Matrix Router)

```
user@host> show chassis firmware lcc 0
```

```
lcc0-re0:
```

```
-----
Part          Type      Version
FPC 1         ROM      Juniper ROM Monitor Version 6.4b18
              O/S      Version 7.0-20040804.0 by userb on 2004-0
FPC 2         ROM      Juniper ROM Monitor Version 6.4b20
```



```

SPMB 0          O/S          Version 7.0-20040804.0 by userb on 2004-0
                ROM          Juniper ROM Monitor Version 6.4b18
                O/S          Version 7.0-20040804.0 by userb on 2004-0

```

show chassis firmware scc (TX Matrix Router)

```

user@host> show chassis firmware scc

scc-re0:
-----
Part          Type      Version
SPMB 0        ROM      Juniper ROM Monitor Version 6.4b18
              O/S      Version 7.0-20040804.0 by userb on 2004-0

```

show chassis firmware (TX Matrix Plus Router)

```

user@host> show chassis firmware

sfc0-re0:
-----
Part          Type      Version
Global FPC 4
Global FPC 6
Global FPC 7
Global FPC 12
Global FPC 14
Global FPC 15
Global FPC 20
Global FPC 21
Global FPC 22
Global FPC 23
Global FPC 24
Global FPC 25
Global FPC 26
Global FPC 28
Global FPC 29
Global FPC 31
SPMB 0        ROM      Juniper ROM Monitor Version 9.5b1
              O/S      Version 9.6-20090507.0 by userb on 2009-0
SPMB 1        ROM      Juniper ROM Monitor Version 9.5b1
              O/S      Version 9.6-20090507.0 by userb on 2009-0

```

lcc0-re1:

```
-----
```

Part	Type	Version
FPC 4	ROM	Juniper ROM Monitor Version 9.0b2
	O/S	Version 9.6-20090507.0 by userb on 2009-0
FPC 6	ROM	Juniper ROM Monitor Version 9.0b2
	O/S	Version 9.6-20090507.0 by userb on 2009-0
FPC 7	ROM	Juniper ROM Monitor Version 9.0b2
	O/S	Version 9.6-20090507.0 by userb on 2009-0
SPMB 0	ROM	Juniper ROM Monitor Version 9.5b1
	O/S	Version 9.6-20090507.0 by userb on 2009-0
SPMB 1	ROM	Juniper ROM Monitor Version 9.5b1
	O/S	Version 9.6-20090507.0 by userb on 2009-0

lcc1-re1:

```
-----
```

Part	Type	Version
FPC 4	ROM	Juniper ROM Monitor Version 9.0b2
	O/S	Version 9.6-20090507.0 by userb on 2009-0
FPC 6	ROM	Juniper ROM Monitor Version 9.0b2
	O/S	Version 9.6-20090507.0 by userb on 2009-0
FPC 7	ROM	Juniper ROM Monitor Version 9.0b2
	O/S	Version 9.6-20090507.0 by userb on 2009-0
SPMB 0	ROM	Juniper ROM Monitor Version 9.5b1
	O/S	Version 9.6-20090507.0 by userb on 2009-0
SPMB 1	ROM	Juniper ROM Monitor Version 9.5b1
	O/S	Version 9.6-20090507.0 by userb on 2009-0

lcc2-re1:

```
-----
```

Part	Type	Version
FPC 4	ROM	Juniper ROM Monitor Version 9.0b2
	O/S	Version 9.6-20090507.0 by userb on 2009-0
FPC 5	ROM	Juniper ROM Monitor Version 9.0b2
	O/S	Version 9.6-20090507.0 by userb on 2009-0
FPC 6	ROM	Juniper ROM Monitor Version 9.0b2
	O/S	Version 9.6-20090507.0 by userb on 2009-0
FPC 7	ROM	Juniper ROM Monitor Version 7.5b4
	O/S	Version 9.6-20090507.0 by userb on 2009-0
SPMB 0	ROM	Juniper ROM Monitor Version 9.5b1
	O/S	Version 9.6-20090507.0 by userb on 2009-0
SPMB 1	ROM	Juniper ROM Monitor Version 9.5b1

```

O/S          Version 9.6-20090507.0 by userb on 2009-0

lcc3-rel:
-----
Part          Type          Version
FPC 0         ROM          Juniper ROM Monitor Version 9.0b2
              O/S          Version 9.6-20090507.0 by userb on 2009-0
FPC 1         ROM          Juniper ROM Monitor Version 9.0b2
              O/S          Version 9.6-20090507.0 by userb on 2009-0
FPC 2         ROM          Juniper ROM Monitor Version 9.0b2
              O/S          Version 9.6-20090507.0 by userb on 2009-0
FPC 4         ROM          Juniper ROM Monitor Version 7.5b4
              O/S          Version 9.6-20090507.0 by userb on 2009-0
FPC 5         ROM          Juniper ROM Monitor Version 9.0b2
              O/S          Version 9.6-20090507.0 by userb on 2009-0
FPC 7         ROM          Juniper ROM Monitor Version 9.0b2
              O/S          Version 9.6-20090507.0 by userb on 2009-0
SPMB 0        ROM          Juniper ROM Monitor Version 9.5b1
              O/S          Version 9.6-20090507.0 by userb on 2009-0
SPMB 1        ROM          Juniper ROM Monitor Version 9.5b1
              O/S          Version 9.6-20090507.0 by userb on 2009-0

```

show chassis firmware lcc (TX Matrix Plus Router)

```

user@host> show chassis firmware lcc 0
lcc0-rel:
-----
Part          Type          Version
FPC 4         ROM          Juniper ROM Monitor Version 9.0b2
              O/S          Version 9.6-20090507.0 by userb on 2009-0
FPC 6         ROM          Juniper ROM Monitor Version 9.0b2
              O/S          Version 9.6-20090507.0 by userb on 2009-0
FPC 7         ROM          Juniper ROM Monitor Version 9.0b2
              O/S          Version 9.6-20090507.0 by userb on 2009-0
SPMB 0        ROM          Juniper ROM Monitor Version 9.5b1
              O/S          Version 9.6-20090507.0 by userb on 2009-0
SPMB 1        ROM          Juniper ROM Monitor Version 9.5b1
              O/S          Version 9.6-20090507.0 by userb on 2009-0

```

show chassis firmware sfc (TX Matrix Plus Router)

```

user@host> show chassis firmware sfc 0
sfc0-re0:
-----
Part                Type      Version
Global FPC 4
Global FPC 6
Global FPC 7
Global FPC 12
Global FPC 14
Global FPC 15
Global FPC 20
Global FPC 21
Global FPC 22
Global FPC 23
Global FPC 24
Global FPC 25
Global FPC 26
Global FPC 28
Global FPC 29
Global FPC 31
SPMB 0              ROM      Juniper ROM Monitor Version 9.5b1
                   O/S      Version 9.6-20090507.0 by userb on 2009-0
SPMB 1              ROM      Juniper ROM Monitor Version 9.5b1
                   O/S      Version 9.6-20090507.0 by userb on 2009-0

```

show chassis firmware (QFX Series and OCX Series)

```

user@switch> show chassis firmware
Part                Type      Version
FPC 0
Routing Engine 0    U-Boot    U-Boot 1.1.6 (Sep 15 2010 - 02:11:11) 1.0.5
                   loader    FreeBSD/MIPS U-Boot bootstrap loader 0.1

```

show chassis firmware (PTX1000 Packet Transport Routers)

```

user@host> show chassis firmware
Part                Type      Version

```

```

FPC 0          U-Boot      ***
               loader      FreeBSD/i386 bootstrap loader 1.2
               BIOS        V0018.2U
               EC FPGA     2.0
               MAIN_CPLD   1.f
               MEZZ_CPLD   1.f
               RE FPGA     2.3

```

show chassis firmware (PTX10008 Routers)

```

user@host> show chassis firmware
Part          Type      Version
RE 0          PRI BIOS  QFXS_SFP_00.31_01.01
              GDN BIOS  QFXS_SFP_00.31_01.01
              FPGA      2.4
              RE-FPGA  3.2
RE 1          PRI BIOS  QFXS_SFP_00.31_01.01
              GDN BIOS  QFXS_SFP_00.31_01.01
              FPGA      2.3
              RE-FPGA  3.2
FPC 0          U-Boot    Bank A: U-Boot 2011.12-gfbea47a (Feb 26 2016 - 22:56:52)
              CTRL FPGA  4.1
              PORT FPGA  2.0
FPC 5          U-Boot    Bank A: U-Boot 2011.12-gfbea47a (Feb 26 2016 - 22:56:52)
              CTRL FPGA  3.1
              PORT FPGA  2.0
FPC 6          U-Boot    Bank B: U-Boot 2011.12-gfbea47a (Feb 26 2016 - 22:56:52)
              CTRL FPGA  3.1
              PORT FPGA  2.0
FPM           FPGA      1.9
FTC 0         FPGA      2.0
FTC 1         FPGA      2.0
SIB 0         FPGA      3.0
SIB 1         FPGA      3.0

```

show chassis firmware interconnect-device (QFabric System)

```

user@switch> show chassis firmware interconnect-device
interconnect1
Part          Type      Version

```

Routing Engine 0	U-Boot loader	U-Boot 1.1.6 (May 10 2011 - 04:52:59) 1.1.1 FreeBSD/MIPS U-Boot bootstrap loader 0.1
Routing Engine 1	U-Boot loader	U-Boot 1.1.6 (May 10 2011 - 04:52:59) 1.1.1 FreeBSD/MIPS U-Boot bootstrap loader 0.1

show chassis firmware (ACX2000 Universal Metro Router)

```
user@switch> show chassis firmware
```

Part	Type	Version
FPC	O/S	Version 12.2I13 by user2 on 2012-05-29 06:
FEB	O/S	Version 12.2I13 by user2 on 2012-05-29 06:

show chassis firmware detail (EX3300 Switch)

```
user@switch> show chassis firmware detail
```

FPC 0

Boot SYSPLD	3
PoE firmware	4.1.6
PFE-0	3
PFE-1	3

PHY

microcode	0x514
-----------	-------

Boot Firmware

uboot	U-Boot 1.1.6 (Aug 21 2011 - 01:45:26)	1.0.0
loader	FreeBSD/arm U-Boot loader	1.0

show chassis firmware (MX Routers with Media Services Blade [MSB])

```
user@switch> show chassis firmware
```

Part	Type	Version
FPC 1	ROM	Juniper ROM Monitor Version 12.1b1
	O/S	Version 12.2I21 by user1 on 2012-06-19 17:

show chassis firmware (ACX5048 Router)

```

user@host> show chassis firmware
Part          Type          Version
FPC           loader        FreeBSD/i386 bootstrap loader 1.2
              BIOS          V0018.7
              TMC FPGA      6.d8
              PIC0 CPLD0    7.b
              PIC0 CPLD1    7.b
              PIC0 CPLD2    7.b
              PIC0 CPLD3    7.b
              PIC0 CPLD4    7.b
              PIC0 CPLD5    7.b
              PIC0 CPLD6    6.a
              MRE          17.9
              Power CPLD  3.a

```

show chassis firmware (ACX5096 Router)

```

user@host> show chassis firmware
Part          Type          Version
FPC           loader        FreeBSD/i386 bootstrap loader 1.2
              BIOS          V0018.7
              TMC FPGA      3000001.5
              PIC0 CPLD0    7.b
              PIC0 CPLD1    7.b
              PIC0 CPLD2    7.b
              PIC0 CPLD3    7.b
              PIC0 CPLD4    7.b
              PIC0 CPLD5    7.b
              PIC0 CPLD6    c6.a
              PIC0 CPLD7    -NA-
              PIC0 CPLD8    7.b
              PIC0 CPLD9    7.b
              PIC0 CPLD10   7.b
              PIC0 CPLD11   7.b
              PIC0 CPLD12   7.b
              PIC0 CPLD13   7.b
              PIC0 CPLD14  c6.a

```

```
MRE          7.5
Power CPLD 4.1
```

show chassis firmware (ACX500 Router)

```
user@host> show chassis firmware
```

Part	Type	Version
FPC	0/S	Version 15.2-20150815_dev_rbu_1_16q1.0 by userb on 2015-08-15 04:18:02 UTC
FEB	0/S	Version 15.2-20150815_dev_rbu_1_16q1.0 by userb on 2015-08-15 04:18:02 UTC

Release Information

Command introduced before Junos OS Release 7.4.

sfc option introduced in Junos OS Release 9.6 for the TX Matrix Plus router.

Command introduced for EX8200 switches in Junos OS Release 10.2 for EX Series switches.

satellite option introduced in Junos OS Release 14.2R3.

show chassis hardware

IN THIS SECTION

- [Syntax | 550](#)
- [Syntax \(EX Series Devices, MX104, MX204, MX2010, MX2020, MX10003, MX10008, and MX2008 Universal Routing Platforms\) | 550](#)
- [Syntax \(TX Matrix Router\) | 550](#)
- [Syntax \(TX Matrix Plus Router\) | 551](#)
- [Syntax \(MX Series Devices\) | 551](#)
- [Syntax \(QFX Series\) | 551](#)
- [Description | 551](#)

- Options | 552
- Additional Information | 553
- Required Privilege Level | 554
- Output Fields | 554
- Sample Output | 558
- show chassis hardware (SRX5800) | 573
- Release Information | 576

Syntax

```
show chassis hardware
<detail | extensive>
<clei-models>
<models>
```

Syntax (EX Series Devices, MX104, MX204, MX2010, MX2020, MX10003, MX10008, and MX2008 Universal Routing Platforms)

```
show chassis hardware
<clei-models>
<detail | extensive>
<models>
<satellite [slot-id slot-id | device-alias alias-name]>
```

Syntax (TX Matrix Router)

```
show chassis hardware
<clei-models>
<detail | extensive>
<models>
<lcc number / scc>
```

Syntax (TX Matrix Plus Router)

```
show chassis hardware
<clei-models>
<detail | extensive>
<models>
<lcc number | sfc number>
```

Syntax (MX Series Devices)

```
show chassis hardware
<detail | extensive>
<clei-models>
<models>
<all-members>
<local>
<member member-id>
```

Syntax (QFX Series)

```
show chassis hardware
<detail | extensive>
<clei-models>
<interconnect-device name>
<node-device name>
<models>
```

Description

Display a list of all Flexible PIC Concentrators (FPCs) and PICs installed in the router or switch chassis, including the hardware version level and serial number.

In the EX Series switch command output, FPC refers to the following:

- On EX2200 switches, EX3200 switches, EX4200 standalone switches, and EX4500 switches—Refers to the switch; FPC *number* is always 0.
- On EX4200 switches in a Virtual Chassis configuration—Refers to the member of a Virtual Chassis; FPC *number* equals the member ID, from 0 through 9.

- On EX8208 and EX8216 switches—Refers to a line card; FPC *number* equals the slot number for the line card.

On QFX3500, QFX5100, and OCX Series standalone switches, and PTX1000 devices both the FPC and FPC *number* are always 0.

On T4000 Type 5 FPCs, there are no top temperature sensor or bottom temperature sensor parameters. Instead, fan intake temperature sensor and fan exhaust temperature sensors parameters are displayed.

Starting from Junos OS Release 11.4, the output of the `show chassis hardware models operational mode` command displays the enhanced midplanes FRU model numbers (CHAS-BP3-MX240-S, CHAS-BP3-MX480-S or CHAS-BP3-MX960-S) based on the router. Prior to release 11.4, the FRU model numbers are left blank when the router has enhanced midplanes. Note that the enhanced midplanes are introduced through the Junos OS Release 13.3, but can be supported on all Junos OS releases.

Starting with Junos OS Release 14.1, the output of the `show chassis hardware detail | extensive | clei-models | models operational mode` command displays the new DC power supply module (PSM) and power distribution unit (PDU) that are added to provide power to the high-density FPC (FPC2-PTX-P1A) and other components in a PTX5000 Packet Transport Router.

Options

none	Display information about hardware. For a TX Matrix router, display information about the TX Matrix router and its attached T640 devices. For a TX Matrix Plus router, display information about the TX Matrix Plus router and its attached devices.
clei-models	(Optional) Display Common Language Equipment Identifier (CLEI) barcode and model number for orderable field-replaceable units (FRUs).
detail	(Optional) Include RAM and disk information in output.
extensive	(Optional) Display ID EEPROM information.
all-members	(MX Series devices only) (Optional) Display hardware-specific information for all the members of the Virtual Chassis configuration.
interconnect-device <i>name</i>	(QFabric systems only) (Optional) Display hardware-specific information for the Interconnect device.
lcc <i>number</i>	(TX Matrix devices and TX Matrix Plus router only) (Optional) On a TX Matrix router, display hardware information for a specified T640 router (line-card chassis) that is connected to the TX Matrix router. On a TX Matrix Plus router, display hardware information for a specified router (line-card chassis) that is connected to the TX Matrix Plus router.

Replace *number* with the following values depending on the LCC configuration:

- 0 through 3, when T640 devices are connected to a TX Matrix router in a routing matrix.
- 0 through 3, when T1600 devices are connected to a TX Matrix Plus router in a routing matrix.
- 0 through 7, when T1600 devices are connected to a TX Matrix Plus router with 3D SIBs in a routing matrix.
- 0, 2, 4, or 6, when T4000 devices are connected to a TX Matrix Plus router with 3D SIBs in a routing matrix.

local	(MX Series devices only) (Optional) Display hardware-specific information for the local Virtual Chassis members.
member <i>member-id</i>	(MX Series devices and EX Series switches) (Optional) Display hardware-specific information for the specified member of the Virtual Chassis configuration. Replace <i>member-id</i> variable with a value 0 or 1.
models	(Optional) Display model numbers and part numbers for orderable FRUs and, for components that use ID EEPROM format v2, the CLEI code.
node-device <i>name</i>	(QFabric systems only) (Optional) Display hardware-specific information for the Node device.
satellite [slot-id <i>slot-id</i> device-alias <i>alias-name</i>]	(Junos Fusion only) (Optional) Display hardware information for the specified satellite device in a Junos Fusion, or for all satellite devices in the Junos Fusion if no satellite devices are specified.
scc	(TX Matrix router only) (Optional) Display hardware information for the TX Matrix router (switch-card chassis).
sfc <i>number</i>	(TX Matrix Plus router only) (Optional) Display hardware information for the TX Matrix Plus router (switch-fabric chassis). Replace <i>number</i> variable with 0.

Additional Information

The `show chassis hardware detail` command now displays DIMM information for the following Routing Engines, as shown in [Table 20 on page 554](#).

Table 20: Routing Engines Displaying DIMM Information

Routing Engines	Devices
RE-S-1800x2 and RE-S-1800x4	MX240, MX480, and MX960 devices
RE-A-1800x2	M120 and M320 devices

In Junos OS Release 11.4 and later, the output for the `show chassis hardware models operational mode` command for MX Series devices display the enhanced midplanes FRU model numbers—CHAS-BP3-MX240-S, CHAS-BP3-MX480-S, or CHAS-BP3-MX960-S—based on the router. In releases before Junos OS Release 11.4, the FRU model numbers are left blank when the router has enhanced midplanes. Note that the enhanced midplanes are introduced through Junos OS Release 13.3, but can be supported on all Junos OS releases.

Starting with Junos OS Release 17.3R1, the output of the `show chassis hardware` command displays the mode in which vMX is running (performance mode or lite mode) in the part number field for the FPC. RIOT-PERF indicates performance mode and RIOT-LITE indicates lite mode.

Starting with Junos OS Release 22.2R1, the RE-S-X6-128G-K Routing Engine (RE) is supported for MX240, MX480, and MX960 devices. View the details of the RE in the command output.

Required Privilege Level

view

Output Fields

[Table 21 on page 554](#) lists the output fields for the `show chassis hardware` command. Output fields are listed in the approximate order in which they appear.

Table 21: show chassis hardware Output Fields

Field Name	Field Description	Level of Output
Item	Show information about the device hardware.	All levels
Version	Revision level of the chassis component.	All levels
Part number	Part number of the chassis component.	All levels

Table 21: show chassis hardware Output Fields (Continued)

Field Name	Field Description	Level of Output
Serial number	Serial number of the chassis component. The serial number of the backplane is also the serial number of the router chassis. Use this serial number when you need to contact Juniper Networks Customer Support about the router or switch chassis.	All levels
Assb ID or Assembly ID	(extensive keyword only) Identification number that describes the FRU hardware.	extensive
Assembly Version	(extensive keyword only) Version number of the FRU hardware.	extensive
Assembly Flags	(extensive keyword only) Flags.	extensive
FRU model number	(clei-models, extensive, and models keyword only) Model number of the FRU hardware component.	none specified
CLEI code	(clei-models and extensive keyword only) Common Language Equipment Identifier code. This value is displayed only for hardware components that use ID EEPROM format v2. This value is not displayed for components that use ID EEPROM format v1.	none specified
EEPROM Version	ID EEPROM version used by the hardware component: 0x00 (version 0), 0x01 (version 1), or 0x02 (version 2).	extensive

Table 21: show chassis hardware Output Fields (Continued)

Field Name	Field Description	Level of Output
Description	<p data-bbox="446 367 852 394">Brief description of the hardware item:</p> <ul data-bbox="446 426 1193 661" style="list-style-type: none"> <li data-bbox="446 426 714 453">• Type of power supply. <li data-bbox="446 489 1193 558">• Type of PIC. If the PIC type is not supported on the current software release, the output states Hardware Not Supported. <li data-bbox="446 594 1161 663">• Type of FPC: FPC Type 1, FPC Type 2, FPC Type 3, FPC Type 4 , or FPC Type0C192. <p data-bbox="479 695 1047 722">On EX Series switches, a brief description of the FPC.</p> <p data-bbox="479 753 1193 823">The following list shows the PIM abbreviation in the output and the corresponding PIM name.</p> <ul data-bbox="479 854 1193 1749" style="list-style-type: none"> <li data-bbox="479 854 1193 924">• 2x FE—Either two built-in Fast Ethernet interfaces (fixed PIM) or dual-port Fast Ethernet PIM <li data-bbox="479 955 868 982">• 4x FE—4-port Fast Ethernet ePIM <li data-bbox="479 1014 1193 1083">• 1x GE Copper—Copper Gigabit Ethernet ePIM (one 10-Mbps, 100-Mbps, or 1000-Mbps port) <li data-bbox="479 1115 1079 1142">• 1x GE SFP—SFP Gigabit Ethernet ePIM (one fiber port) <li data-bbox="479 1182 852 1209">• 2x Serial—Dual-port serial PIM <li data-bbox="479 1249 787 1276">• 2x T1—Dual-port T1 PIM <li data-bbox="479 1316 787 1344">• 2x E1—Dual-port E1 PIM <li data-bbox="479 1383 982 1411">• 2x CT1E1—Dual-port channelized T1/E1 PIM <li data-bbox="479 1451 787 1478">• 1x T3—T3 PIM (one port) <li data-bbox="479 1518 787 1545">• 1x E3—E3 PIM (one port) <li data-bbox="479 1585 917 1612">• 4x BRI S/T—4-port ISDN BRI S/T PIM <li data-bbox="479 1652 868 1680">• 4x BRI U—4-port ISDN BRI U PIM <li data-bbox="479 1719 1177 1747">• 1x ADSL Annex A—ADSL 2/2+ Annex A PIM (one port, for POTS) 	All levels

Table 21: show chassis hardware Output Fields (Continued)

Field Name	Field Description	Level of Output
	<ul style="list-style-type: none"> • 1x ADSL Annex B—ADSL 2/2+ Annex B PIM (one port, for ISDN) • 2x SHDSL (ATM)—G SHDSL PIM (2-port two-wire module or 1-port four-wire module) • 1x TGM550—TGM550 Telephony Gateway Module (Avaya VoIP gateway module with one console port, two analog LINE ports, and two analog TRUNK ports) • 1x DS1 TIM510—TIM510 E1/T1 Telephony Interface Module (Avaya VoIP media module with one E1 or T1 trunk termination port and ISDN PRI backup) • 4x FXS, 4xFX0, TIM514—TIM514 Analog Telephony Interface Module (Avaya VoIP media module with four analog LINE ports and four analog TRUNK ports) • 4x BRI TIM521—TIM521 BRI Telephony Interface Module (Avaya VoIP media module with four ISDN BRI ports) • Crypto Accelerator Module—For enhanced performance of cryptographic algorithms used in IP Security (IPsec) services • MPC M 16x 10GE—16-port 10-Gigabit Module Port Concentrator that supports SFP+ optical transceivers. (Not on EX Series switches.) • For hosts, the Routing Engine type. • For small form-factor pluggable transceiver (SFP) modules, the type of fiber: LX, SX, LH, or T. • LCD description for EX Series switches (except EX2200 switches). • MPC2—1-port MPC2 that supports two separate slots for MICs. • MPC3E—1-port MPC3E that supports two separate slots for MICs (MIC-3D-1X100GE-CFP and MIC-3D-20GE-SFP) on MX960, MX480, and MX240 devices. The MPC3E maps one MIC to one PIC (1 MIC, 1 PIC), which differs from the mapping of legacy MPCs. • 100GBASE-LR4, pluggable CFP optics 	

Table 21: show chassis hardware Output Fields (Continued)

Field Name	Field Description	Level of Output
	<ul style="list-style-type: none"> • Supports the Enhanced MX Switch Control Board with fabric redundancy and existing SCBs without fabric redundancy. • Interoperates with existing MX Series line cards, including Flexible Port Concentrators (FPC), Dense Port Concentrators (DPCs), and Modular Port Concentrators (MPCs). • MPC4E—Fixed configuration MPC4E that is available in two flavors: MPC4E-3D-32XGE-SFPP and MPC4E-3D-2CGE-8XGE on MX2020, MX960, MX480, and MX240 devices. • LCD description for MX Series devices 	

Sample Output

show chassis hardware (MX240, MX480, MX960 Devices)

```
user@host> show chassis hardware
```

```
Hardware inventory:
```

Item	Version	Part number	Serial number	Description
Chassis			JN1230686AFB	MX480
Midplane	REV 05	710-017414	ACRB7717	MX480 Midplane
FPM Board	REV 02	710-017254	CADF2017	Front Panel Display
PEM 0	Rev 03	740-022697	QCS1142C0HJ	PS 1.2-1.7kW; 100-240V AC in
PEM 1	Rev 01	740-022697	QCS1035C0CM	PS 1.2-1.7kW; 100-240V AC in
Routing Engine 0	REV 06	711-145342	CASE0160	RE-S-X6-128G-K
CB 0	REV 05	750-055976	CAES7891	Enhanced MX SCB 2
CB 1	REV 12	750-062572	CALM3310	Enhanced MX SCB 2
Fan Tray				Enhanced Left Fan Tray

show chassis hardware (MX10008 Router)

```
user@host> show chassis hardware
```

Hardware inventory:

Item	Version	Part number	Serial number	Description
Chassis			DE538	JNP10008 [MX10008]
Midplane	REV 27	750-054097	ACPD6954	Midplane 8
Routing Engine 0		BUILTIN	BUILTIN	RE X10
Routing Engine 1		BUILTIN	BUILTIN	RE X10 128
CB 0	REV 10	750-079562	CAKF2158	Control Board
CB 1	REV 05	711-065897	CAJG2680	Control Board
FPC 1	REV 04	750-084779	CAKN5706	JNP10K-LC2101
CPU	REV 05	750-073391	CAKJ2864	LC 2101 PMB
PIC 0		BUILTIN	BUILTIN	4xQSFP28 SYNCE
Xcvr 0	REV 01	740-046565	XXL0BQM	QSFP+-40G-SR4
Xcvr 1	REV 01	740-032986	QB350242	QSFP+-40G-SR4
Xcvr 2	REV 01	740-054053	QE408285	QSFP+-4X10G-SR
Xcvr 3	REV 01	740-046565	QF3300Z9	QSFP+-40G-SR4
PIC 1		BUILTIN	BUILTIN	4xQSFP28 SYNCE
Xcvr 0	REV 01	740-067442	QJ2200LD	QSFP+-40G-SR4
Xcvr 1	REV 01	740-038153	APF170500382DP	QSFP+-40G-CU3M
Xcvr 2	REV 01	740-067442	QI4302LC	QSFP+-40G-SR4
PIC 2		BUILTIN	BUILTIN	4xQSFP28 SYNCE
Xcvr 0	REV 01	740-067442	1ACP1335119	QSFP+-40G-SR4
Xcvr 1	REV 01	740-067442	1ACP1313156	QSFP+-40G-SR4
Xcvr 2	REV 01	740-067442	QK050040	QSFP+-40G-SR4
Xcvr 3	REV 01	740-067442	QJ2201BG	QSFP+-40G-SR4
PIC 3		BUILTIN	BUILTIN	4xQSFP28 SYNCE
Xcvr 0	REV 01	740-058734	1ECQ12400CS	QSFP-100GBASE-SR4
Xcvr 1	REV 01	740-046565	QF3300ZX	QSFP+-40G-SR4
Xcvr 2	REV 01	740-061405	1ECQ12510FH	QSFP-100G-SR4-T2
Xcvr 3	REV 01	740-032986	QB491182	QSFP+-40G-SR4
PIC 4		BUILTIN	BUILTIN	4xQSFP28 SYNCE
Xcvr 0	REV 01	740-067442	QJ2200D5	QSFP+-40G-SR4
Xcvr 1	REV 01	740-054053	XXS0L95	QSFP+-4X10G-SR
PIC 5		BUILTIN	BUILTIN	4xQSFP28 SYNCE
Xcvr 0	REV 01	740-054053	QE251550	QSFP+-4X10G-SR
Xcvr 1	REV 01	740-054053	XZB01D5	QSFP+-4X10G-SR
Xcvr 3	REV 01	740-046565	QI1402F9	QSFP+-40G-SR4
FPD Board	REV 07	711-054687	ACPF2896	Front Panel Display
PEM 1	REV 02	740-049388	1EDL62102PR	Power Supply AC
PEM 2	REV 02	740-049388	1EDL60300H2	Power Supply AC
PEM 4	REV 02	740-049388	1EDL603003Z	Power Supply AC
PEM 5	REV 01	740-049388	1EDL339001B	Power Supply AC
FTC 0	REV 14	750-050108	ACNW3344	Fan Controller 8
FTC 1	REV 14	750-050108	ACPE3978	Fan Controller 8

Fan Tray 0	REV 09	760-054372	ACNV5507	Fan Tray 8
Fan Tray 1	REV 09	760-054372	ACNV5371	Fan Tray 8
SFB 0	REV 25	750-050058	ACPH6821	Switch Fabric (SIB) 8
SFB 1				
SFB 2	REV 24	750-050058	ACNZ0641	Switch Fabric (SIB) 8
SFB 3	REV 27	750-050058	ACPH9127	Switch Fabric (SIB) 8
SFB 5	REV 24	750-050058	ACNX7396	Switch Fabric (SIB) 8

show chassis hardware (PTX10008 Router)

```
root@host> show chassis hardware
```

```
Hardware inventory:
```

Item	Version	Part number	Serial number	Description	
Chassis			DK404	JNP10008 [PTX10008]	
Midplane	REV 28	750-054097	ACPP2394	Midplane 8	
Routing Engine 0		BUILTIN	BUILTIN	RE-PTX-2X00x4	
Routing Engine 1		BUILTIN	BUILTIN	RE-PTX-2X00x4	
CB 0	REV 04	750-068820	ACPT5303	Control Board	
CB 1	REV 04	750-068820	ACPR1627	Control Board	
FPC 6	REV 13	750-068822	ACPB2753	LC1102 - 12C / 36Q /	
14					4X
CPU		BUILTIN	BUILTIN	FPC CPU	
PIC 0		BUILTIN	BUILTIN	12x100GE/36x40GE/	
144x10					GE
Xcvr 0	REV 01	740-067442	XV304N6	QSFP+-40G-SR4	
Xcvr 1	REV 01	740-067442	XV30A5M	QSFP+-40G-SR4	
Xcvr 2	REV 01	740-067442	XV300HC	QSFP+-40G-SR4	
Xcvr 3	REV 01	740-067443	XU20L17	QSFP+-40G-SR4	
Xcvr 4	REV 01	740-067442	XV303XG	QSFP+-40G-SR4	
Xcvr 5	REV 01	740-067443	XV306QC	QSFP+-40G-SR4	
Xcvr 6	REV 01	740-067442	XV303Y7	QSFP+-40G-SR4	
Xcvr 7	REV 01	740-067443	XX60DMR	QSFP+-40G-SR4	
Xcvr 9	REV 01	740-067443	XX60DNY	QSFP+-40G-SR4	
Xcvr 10	REV 01	740-054053	QF4605WF	QSFP+-4X10G-SR	
Xcvr 13	REV 01	740-058734	1ECQ115007D	QSFP-100GBASE-SR4	
Xcvr 15	REV 01	740-046565	QH06035R	QSFP+-40G-SR4	
Xcvr 16	REV 01	740-046565	QH0602KC	QSFP+-40G-SR4	
Xcvr 17	REV 01	740-046565	QH0507PA	QSFP+-40G-SR4	
Xcvr 18	REV 01	740-046565	QH06035M	QSFP+-40G-SR4	
Xcvr 24	REV 01	740-046565	QH0507QL	QSFP+-40G-SR4	
Xcvr 25	REV 01	740-067443	XV20CWP	QSFP+-40G-SR4	

Xcvr 34	REV 01	740-046565	QH06035U	QSFP+-40G-SR4
Xcvr 35	REV 01	740-067443	XX60DN9	QSFP+-40G-SR4
FPC 7	REV 41	750-051357	ACPL3446	LC1101 - 30C / 30Q / 96X
CPU		BUILTIN	BUILTIN	FPC CPU
PIC 0		BUILTIN	BUILTIN	30x100GE/30x40GE/96x10GE
Xcvr 0	REV 01	740-067443	XX60DPC	QSFP+-40G-SR4
Xcvr 1	REV 01	740-054053	QF4605W7	QSFP+-4X10G-SR
Xcvr 2	REV 01	740-067443	XX60DP8	QSFP+-40G-SR4
Xcvr 3	REV 01	740-067442	XV30FYM	QSFP+-40G-SR4
Xcvr 4	REV 01	740-067442	1ACP133406Z	QSFP+-40G-SR4
Xcvr 5	REV 01	740-067443	XX60DP5	QSFP+-40G-SR4
Xcvr 8	REV 01	740-046565	QH060355	QSFP+-40G-SR4
Xcvr 12	REV 01	740-058734	1ECQ115008C	QSFP-100GBASE-SR4
Xcvr 15	REV 01	740-046565	QH0602KG	QSFP+-40G-SR4
Xcvr 16	REV 01	740-046565	QH0602LG	QSFP+-40G-SR4
Xcvr 17	REV 01	740-046565	QH06035S	QSFP+-40G-SR4
Xcvr 18	REV 01	740-046565	QH0602KS	QSFP+-40G-SR4
Xcvr 24	REV 01	740-067443	QI2902DP	QSFP+-40G-SR4
Power Supply 2	REV 02	740-049388	1EDL70200NP	Power Supply AC
Power Supply 3	REV 02	740-049388	1EDL603005C	Power Supply AC
Power Supply 4	REV 02	740-049388	1EDL70200P1	Power Supply AC
Power Supply 5	REV 02	740-049388	1EDL70200B7	Power Supply AC
FTC 0	REV 16	750-050108	ACPK8682	Fan Controller 8
FTC 1	REV 16	750-050108	ACPR9530	Fan Controller 8
Fan Tray 0	REV 10	760-054372	ACPR9509	Fan Tray 8
Fan Tray 1	REV 10	760-054372	ACPV7260	Fan Tray 8
SIB 1	REV 28	750-050058	ACPV6306	Switch Fabric 8
SIB 2	REV 28		ACPR2569	Switch Fabric 8
SIB 3	REV 28	750-05	ACPW7402	Switch Fabric 8
SIB 4	REV 28	750-050058	ACPR2577	Switch Fabric 8
FPD Board	REV 07	711-054687	ACPM4965	Front Panel Display

show chassis hardware (PTX10016 Router Junos OS Evolved Release)

```

user@host> show chassis hardware
Hardware inventory:
Item          Version  Part number  Serial number  Description
Chassis                               DY814         JNP10016 [PTX10016]
Midplane 0    REV 02   750-085608  BCAX3258      Midplane 16
FPM 0         REV 01   711-086964  BCAR0775      Front Panel Display
PSM 0         Rev 03   740-069994  1F269200046  JNP10K 5500W AC/HVDC Power Supply Unit

```

PSM 1	Rev 03	740-069994	1F269170144	JNP10K 5500W AC/HVDC Power Supply Unit
PSM 2	REV 02	740-049388	1EDL60300C6	JNP10K 5500W AC/HVDC Power Supply Unit
PSM 3	REV 02	740-049388	1EDL603005X	JNP10K 5500W AC/HVDC Power Supply Unit
PSM 4	REV 02	740-049388	1EDL6170275	JNP10K 5500W AC/HVDC Power Supply Unit
PSM 5	REV 02	740-049388	1EDL61701WD	JNP10K 5500W AC/HVDC Power Supply Unit
Routing Engine 0		BUILTIN	BUILTIN	JNP10K-RE1-E
CB 0	REV 15	750-079562	BCAW3941	Control Board
Routing Engine 1		BUILTIN	BUILTIN	JNP10K-RE1-E
CB 1	REV 15	750-079562	BCAW3942	Control Board
FPC 0	REV 07	750-093524	BCAY8271	JNP10K-LC1201
CPU	REV 14	710-001726	HM1084	FPC CPU
FPC 10	REV 07	750-093524	BCAY8277	JNP10K-LC1201CPU
710-010169	HZ3219		FPC CPU-Enhanced	REV 05
SIB 0	REV 02	750-083426	BCAV7680	SIB-JNP10016
SIB 1	REV 02	750-083426	BCAV7682	SIB-JNP10016
SIB 2	REV 02	750-083426	BCAV7681	SIB-JNP10016
SIB 3	REV 02	750-083426	BCAV7684	SIB-JNP10016
SIB 4	REV 02	750-083426	BCAV7683	SIB-JNP10016
SIB 5	REV 02	750-083426	BCAV7685	SIB-JNP10016
FTC 0	REV 10	750-086270	BCAV0609	Fan Controller 16
Fan Tray 0	REV 02	750-103311	BCAY1793	Fan Tray 16
Fan Tray 1	REV 02	750-103311	BCAY1797	Fan Tray 16

show chassis hardware clei-models (PTX10016 Router)

```

user@host> show chassis hardware clei-models
Hardware inventory:
Item          Version  Part number  CLEI code      FRU model number
Midplane      REV 24   750-077138  CMMUN00ARA     JNP10016
CB 0          REV 04   711-065897  PROTOXCLEI     PROTO-ASSEMBLY
CB 1          REV 05   711-065897  PROTOXCLEI     PROTO-ASSEMBLY
FPC 2
  PIC 0       BUILTIN
FPC 4          REV 35   750-071976  CMUIANABAA     JNP10K-LC1101
  PIC 0       BUILTIN
FPC 5          REV 13   750-068822  CMUIAM9BAC     QFX10000-36Q
  PIC 0       BUILTIN
FPC 6          REV 41   750-071976  CMUIANABAB     JNP10K-LC1101
  PIC 0       BUILTIN
FPC 7          REV 35   750-071976  CMUIANABAA     JNP10K-LC1101
  PIC 0       BUILTIN

```

FPC 8	REV 35	750-071976	CMUIANABAA	JNP10K-LC1101
PIC 0		BUILTIN		
FPC 9	REV 41	750-071976	CMUIANABAB	JNP10K-LC1101
PIC 0		BUILTIN		
FPC 10	REV 35	750-071976	CMUIANABAA	JNP10K-LC1101
PIC 0		BUILTIN		
FPC 11	REV 35	750-071976	CMUIANABAA	JNP10K-LC1101
PIC 0		BUILTIN		
FPC 13	REV 41	750-071976	CMUIANABAB	JNP10K-LC1101
PIC 0		BUILTIN		
FPC 15	REV 37	750-071976	CMUIANABAA	JNP10K-LC1101
PIC 0		BUILTIN		
Power Supply 0	REV 01	740-073147	CMUPADPBAA	JNP10K-PWR-DC
Power Supply 1	REV 01	740-073147	CMUPADPBAA	JNP10K-PWR-DC
Power Supply 2	REV 01	740-073147	CMUPADPBAA	JNP10K-PWR-DC
Power Supply 3	REV 01	740-073147	CMUPADPBAA	JNP10K-PWR-DC
Power Supply 4	REV 01	740-073147	CMUPADPBAA	JNP10K-PWR-DC
Power Supply 5	REV 01	740-073147	CMUPADPBAA	JNP10K-PWR-DC
Power Supply 6	REV 01	740-073147	CMUPADPBAA	JNP10K-PWR-DC
Power Supply 7	REV 01	740-073147	CMUPADPBAA	JNP10K-PWR-DC
Power Supply 8	REV 01	740-073147	CMUPADPBAA	JNP10K-PWR-DC
Power Supply 9	REV 01	740-073147	CMUPADPBAA	JNP10K-PWR-DC
Fan Tray 0				QFX5100-FAN-AFO
Fan Tray 1				QFX5100-FAN-AFO
SIB 0	REV 15	750-077140	CMUCAH6CAA	JNP10016-SF
SIB 1	REV 15	750-077140	CMUCAH6CAA	JNP10016-SF
SIB 2	REV 15	750-077140	CMUCAH6CAA	JNP10016-SF
SIB 3	REV 15	750-077140	CMUCAH6CAA	JNP10016-SF
SIB 4	REV 15	750-077140	CMUCAH6CAA	JNP10016-SF
SIB 5	REV 15	750-077140	CMUCAH6CAA	JNP10016-SF
FPD Board	REV 07	711-054687		

show chassis hardware (QFX5700 Router)

```

user@host> show chassis hardware
Hardware inventory:
Item          Version      Part number  Serial number  Description
Chassis                               EC819        JNP5700       [QFX5700]
...
...
...
Routing Engine 0          BUILTIN     BUILTIN      JNP5700-RCB

```

Routing Engine 1		BUILTIN	BUILTIN	JNP5700-RCB
CB 0	REV 15	750-079562	BCAV5526	Control Board
CB 1	REV 15	750-079562	BCAW0403	Control Board

show chassis hardware (SRX5800 Router)

```

user@host> show chassis hardware
show chassis hardware
Hardware inventory:
Item          Version  Part number  Serial number  Description
Chassis                               JN1080B50AFA  MX960
Midplane      REV 02   710-013698  CC6226        MX960 Backplane
Fan Extender  REV 02   710-018051  JY5235        Extended Cable Manager
FPM Board     REV 01   710-014974  JS4207        Front Panel Display
PEM 0         Rev 01   740-080280  1F238510008  MX960-UNIVERSAL-HV-PSM
PEM 1         Rev 01   740-080280  1F238510030  MX960-UNIVERSAL-HV-PSM
PEM 2         Rev 01   740-080280  1F238510023  MX960-UNIVERSAL-HV-PSM
PEM 3         Rev 01   740-080280  1F238510047  MX960-UNIVERSAL-HV-PSM

```

show chassis hardware detail (EX9251 Switch)

```

user@switch> show chassis hardware
Hardware inventory:
Item          Version  Part number  Serial number  Description
Chassis                               BLANK         EX9251
Routing Engine 0      BUILTIN  BUILTIN      RE-S-2X00x6
CB 0             REV 05   750-069579  CAGT1382      EX9251
FPC 0            BUILTIN  BUILTIN      MPC
  PIC 0          BUILTIN  BUILTIN      4XQSFP28 PIC
    Xcvr 0       REV 01   740-044512  APF14500007NHC  QSFP+-40G-CU50CM
    Xcvr 2       REV 01   740-046565  QH21035H       QSFP+-40G-SR4
  PIC 1          BUILTIN  BUILTIN      8XSFP PIC
    Xcvr 0       REV 01   740-031980  AA15393URH7    SFP+-10G-SR
    Xcvr 1       REV 01   740-031980  AA162832LVG    SFP+-10G-SR
    Xcvr 2       REV 01   740-031980  MXA0NKJ        SFP+-10G-SR
    Xcvr 3       REV 01   740-031980  MXA0K75        SFP+-10G-SR
    Xcvr 4       REV 01   740-021308  MXA138L        SFP+-10G-SR
    Xcvr 5       REV 01   740-021308  13T511102684  SFP+-10G-SR

```

Xcvr 6	REV 01	740-021308	MXA138E	SFP+-10G-SR
Xcvr 7	REV 01	740-021308	MXA152N	SFP+-10G-SR
PEM 0	REV 02	740-070749	1F186390060	AC AFO 650W PSU
PEM 1	REV 02	740-070749	1F186390045	AC AFO 650W PSU
Fan Tray 0				Fan Tray, Front to Back Airflow - AFO
Fan Tray 1				Fan Tray, Front to Back Airflow - AFO

show chassis hardware extensive (T640 Router)

```

user@host> show chassis hardware extensive
Hardware inventory:
Item          Version  Part number  Serial number  Description
Chassis                               T640
Jedec Code:   0x7fb0          EEPROM Version: 0x01
P/N:          .....          S/N:           .....
Assembly ID:  0x0507          Assembly Version: 00.00
Date:         00-00-0000     Assembly Flags:  0x00
Version:      .....
ID: Gibson LCC Chassis
Board Information Record:
Address 0x00: 00 00 00 00 00 00 00 00 00 00 00 00 00 00 00 00
I2C Hex Data:
Address 0x00: 7f b0 01 ff 05 07 00 00 00 00 00 00 00 00 00 00
Address 0x10: 00 00 00 00 00 00 00 00 00 00 00 00 00 00 00
Address 0x20: ff ff ff ff ff ff ff ff ff ff ff ff 00 00 00
Address 0x30: 00 00 00 00 00 00 00 00 00 00 00 00 00 00 00
Address 0x40: 00 00 00 00 00 00 00 00 00 00 00 00 00 00 00
Midplane      REV 04   710-002726  AX5633
Jedec Code:   0x7fb0          EEPROM Version: 0x01
P/N:         710-002726.      S/N:           AX5633.
Assembly ID:  0x0127          Assembly Version: 01.04
Date:         06-27-2001     Assembly Flags:  0x00
Version:      REV 04.....
ID: Gibson Backplane
Board Information Record:
Address 0x00: ad 01 08 00 00 90 69 0e f8 00 ff ff ff ff ff
I2C Hex Data:
Address 0x00: 7f b0 01 ff 01 27 01 04 52 45 56 20 30 34 00 00
Address 0x10: 00 00 00 00 37 31 30 2d 30 30 32 37 32 36 00 00
Address 0x20: 53 2f 4e 20 41 58 35 36 33 33 00 00 00 1b 06 07
Address 0x30: d1 ff ff ff ad 01 08 00 00 90 69 0e f8 00 ff ff

```



```

Address 0x40: ff ff ff ff ff ff ff ff ff ff ff ff ff ff ff ff
FPM GBUS      REV 02  710-002901  HE3245
...
FPM Display   REV 02  710-002897  HA4873
...
CIP           REV 05  710-002895  HA4729
...
PEM 1        RevX02  740-002595  MD21815      Power Entry Module
...
SCG 0        REV 04  710-003423  HF6023
...
SCG 1        REV 04  710-003423  HF6061
...
Routing Engine 0 REV 01  740-005022  210865700292  RE-3.0
...
CB 0         REV 06  710-002728  HE3614
...
FPC 1        REV 01  710-002385  HE3009      FPC Type 1
...
...         REV 06  710-001726  HC0010

```

show chassis hardware interconnect-device (QFabric Systems)

```

user@switch> show chassis hardware interconnect-device interconnect1
Hardware inventory:
Item          Version  Part number  Serial number  Description
Chassis       REV 07
Midplane      REV 07  750-021261  BH0208188289  QFX Midplane
CB 0          REV 07  750-021261  BH0208188289  QFXIC08-CB4S

```

show chassis hardware lcc (TX Matrix Router)

```

user@host> show chassis hardware lcc 0
lcc0-re0:
-----
Hardware inventory:
Item          Version  Part number  Serial number  Description
Chassis       REV 03  710-005608  RA1408         T640
Midplane      REV 03  710-005608  RA1408         T640 Backplane
FPM GBUS      REV 09  710-002901  RA2784         T640 FPM Board
FPM Display   REV 05  710-002897  RA2825         FPM Display

```

CIP	REV 06	710-002895	HT0684	T Series CIP
PEM 0	Rev 11	740-002595	PM18483	Power Entry Module
PEM 1	Rev 11	740-002595	qb13984	Power Entry Module
SCG 0	REV 11	710-003423	HT0022	T640 Sonet Clock Gen.
Routing Engine 0	REV 13	740-005022	210865700363	RE-3.0 (RE-600)
CB 0	REV 03	710-007655	HW1195	Control Board (CB-T)
FPC 1	REV 05	710-007527	HM3245	FPC Type 2
CPU	REV 14	710-001726	HM1084	FPC CPU
PIC 0	REV 02	750-007218	AZ1112	2x OC-12 ATM2 IQ, SMIR
PIC 1	REV 02	750-007745	HG3462	4x OC-3 SONET, SMIR
PIC 2	REV 14	750-001901	BA5390	4x OC-12 SONET, SMIR
PIC 3	REV 09	750-008155	HS3012	2x G/E IQ, 1000 BASE
SFP 0		NON-JNPR	P1186TY	SFP-S
SFP 1	REV 01	740-007326	P11WLTF	SFP-SX
MMB 1	REV 02	710-005555	HL7514	MMB-288mbit
PPB 0	REV 04	710-003758	HM4405	PPB Type 2
PPB 1	REV 04	710-003758	AV1960	PPB Type 2
FPC 2	REV 08	710-010154	HZ3578	E-FPC Type 3
CPU	REV 05	710-010169	HZ3219	FPC CPU-Enhanced
PIC 0	REV 02	750-009567	HX2882	1x 10GE(LAN), XENPAK
SFP 0	REV 01	740-009898	USC202U709	XENPAK-LR
PIC 1	REV 03	750-003336	HJ9954	4x OC-48 SONET, SMSR
PIC 2	REV 01	750-004535	HC0235	1x OC-192 SM SR1
PIC 3	REV 07	750-007141	HX1699	10x 1GE(LAN), 1000 BASE
SFP 0	REV 01	740-007326	2441042	SFP-SX
SFP 1	REV 01	740-007326	2441027	SFP-SX
MMB 0	REV 03	710-010171	HV2365	MMB-5M3-288mbit
MMB 1	REV 03	710-010171	HZ3888	MMB-5M3-288mbit
SPMB 0	REV 09	710-003229	HW5245	T Series Switch CPU
SIB 3	REV 07	710-005781	HR5927	SIB-L8-F16
B Board	REV 06	710-005782	HR5971	SIB-L8-F16 (B)
SIB 4	REV 07	710-005781	HR5903	SIB-L8-F16
B Board	REV 06	710-005782	HZ5275	SIB-L8-F16 (B)

show chassis hardware models (MX2010 Router)

```

user@host > show chassis hardware models
Hardware inventory:
Item          Version  Part number  Serial number  FRU model number
FPM Board    REV 06   711-032349  ZX8744        711-032349
PSM 4        REV 0C   740-033727  VK00254      00000000000000000000000000000000

```

PSM 5	REV 0B	740-033727	VG00015	00000000000000000000
PSM 6	REV 0B	740-033727	VH00097	00000000000000000000
PSM 7	REV 0C	740-033727	VJ00151	00000000000000000000
PSM 8	REV 0C	740-033727	VJ00149	00000000000000000000
PDM 0	REV 0B	740-038109	WA00008	
PDM 1	REV 0B	740-038109	WA00014	
Routing Engine 0	REV 02	740-041821	9009094134	RE-S-1800X4-16G-S
Routing Engine 1	REV 02	740-041821	9009094141	RE-S-1800X4-16G-S
CB 0	REV 08	750-040257	CAAB3491	750-040257
CB 1	REV 08	750-040257	CAAB3489	750-040257
SFB 0	REV 06	711-032385	ZV1828	711-032385
SFB 1	REV 07	711-032385	ZZ2568	711-032385
SFB 2	REV 07	711-032385	ZZ2563	711-032385
SFB 3	REV 07	711-032385	ZZ2564	711-032385
SFB 4	REV 07	711-032385	ZZ2580	711-032385
SFB 5	REV 07	711-032385	ZZ2579	711-0323856
SFB 6	REV 07	711-032385	CAAB4882	711-044170
SFB 7	REV 07	711-032385	CAAB4898	711-044170
FPC 0	REV 33	750-028467	CAAB1919	MPC-3D-16XGE-SFPP
FPC 1	REV 21	750-033205	ZG5027	MX-MPC3-3D
MIC 0	REV 03	750-033307	ZV6299	MIC3-3D-10XGE-SFPP
MIC 1	REV 03	750-033307	ZV6268	MIC3-3D-10XGE-SFPP
FPC 8	REV 22	750-031089	ZT9746	MX-MPC2-3D
MIC 0	REV 26	750-028392	ABBS1150	MIC-3D-20GE-SFP
MIC 1	REV 26	750-028387	ABBR9582	MIC-3D-4XGE-XFP
FPC 9	REV 11	750-036284	ZL3591	MPCE-3D-16XGE-SFPP
ADC 0	REV 05	750-043596	CAAC2073	750-043596
ADC 1	REV 01	750-043596	ZV4117	750-043596
ADC 8	REV 01	750-043596	ZV4107	750-043596
ADC 9	REV 02	750-043596	ZW1555	750-043596
Fan Tray 0	REV 2A	760-046960	ACAY0015	
Fan Tray 1	REV 2A	760-046960	ACAY0019	
Fan Tray 2	REV 2A	760-046960	ACAY0020	
Fan Tray 3	REV 2A	760-046960	ACAY0021	

show chassis hardware node-device (QFabric Systems)

```

user@switch> show chassis hardware node-device node1
Routing Engine 0  BUILTIN      BUILTIN      QFX Routing Engine
node1             REV 05      711-032234  ED3694      QFX3500-48S4Q-AFI

```

CPU		BUILTIN	BUILTIN	FPC CPU
PIC 0		BUILTIN	BUILTIN	48x 10G-SFP+
Xcvr 8	REV 01	740-030658	AD0946A028B	SFP+-10G-USR

show chassis hardware scc (TX Matrix Router)

```
user@host> show chassis hardware scc
```

```
scc-re0:
```

```
-----
```

Hardware inventory:

Item	Version	Part number	Serial number	Description
Chassis				TX Matrix
Midplane	REV 04	710-004396	RB0014	SCC Midplane
FPM GBUS	REV 04	710-004617	HW9141	SCC FPM Board
FPM Display	REV 04	710-004619	HS5950	SCC FPM
CIP 0	REV 01	710-010218	HV9151	SCC CIP
CIP 1	REV 01	710-010218	HV9152	SCC CIP
PEM 1	Rev 11	740-002595	QB13977	Power Entry Module
Routing Engine 0	REV 05	740-008883	P11123900153	RE-4.0 (RE-1600)
CB 0	REV 01	710-011709	HR5964	Control Board (CB-TX)
SPMB 0	REV 09	710-003229	HW5293	T Series Switch CPU
SIB 3				
SIB 4	REV 01	710-005839	HW1177	SIB-S8-F16
B Board	REV 01	710-005840	HW1202	SIB-S8-F16 (B)

show chassis hardware sfc (TX Matrix Plus Router)

```
user@host> show chassis hardware sfc 0
```

```
sfc0-re0:
```

```
-----
```

Hardware inventory:

Item	Version	Part number	Serial number	Description
Chassis			JN112F007AHB	TXP
Midplane	REV 05	710-022574	TS4027	SFC Midplane
FPM Display	REV 03	710-024027	DX0282	TXP FPM Display
CIP 0	REV 04	710-023792	DW4889	TXP CIP
CIP 1	REV 04	710-023792	DW4887	TXP CIP
PEM 0	Rev 07	740-027463	UM26368	Power Entry Module
Routing Engine 0	REV 01	740-026942	737A-1064	SFC RE
Routing Engine 1	REV 01	740-026942	737A-1082	SFC RE

CB 0	REV 09	710-022606	DW6099	SFC Control Board
CB 1	REV 09	710-022606	DW6096	SFC Control Board
SPMB 0		BUILTIN		SFC Switch CPU
SPMB 1		BUILTIN		SFC Switch CPU
SIB F13 0	REV 04	710-022600	DX0841	F13 SIB
B Board	REV 03	710-023431	DX0966	F13 SIB Mezz
SIB F13 1	REV 04	750-024564	DW5776	F13 SIB
B Board	REV 03	710-023431	DW9028	F13 SIB
SIB F13 3	REV 04	750-024564	DW5762	F13 SIB
B Board	REV 03	710-023431	DW9059	F13 SIB
SIB F13 4	REV 04	750-024564	DW5797	F13 SIB
B Board	REV 03	710-023431	DW9041	F13 SIB
SIB F13 6	REV 04	750-024564	DW5770	F13 SIB
B Board	REV 03	710-023431	DW9079	F13 SIB Mezz
SIB F13 7	REV 04	750-024564	DW5758	F13 SIB
B Board	REV 03	710-023431	DW9047	F13 SIB
SIB F13 8	REV 04	750-024564	DW5761	F13 SIB
B Board	REV 03	710-023431	DW9043	F13 SIB Mezz
SIB F13 9	REV 04	750-024564	DW5754	F13 SIB
B Board	REV 03	710-023431	DW9078	F13 SIB Mezz
SIB F13 11	REV 04	710-022600	DX0826	F13 SIB
B Board	REV 03	710-023431	DX0967	F13 SIB Mezz
SIB F13 12	REV 04	750-024564	DW5794	F13 SIB
B Board	REV 03	710-023431	DW9044	F13 SIB Mezz
SIB F2S 0/0	REV 05	710-022603	DW7897	F2S SIB
B Board	REV 05	710-023787	DW7657	NEO PMB
SIB F2S 0/2	REV 05	710-022603	DW7833	F2S SIB
B Board	REV 05	710-023787	DW7526	NEO PMB
SIB F2S 0/4	REV 05	710-022603	DW7875	F2S SIB
B Board	REV 05	710-023787	DW7588	NEO PMB
SIB F2S 0/6	REV 05	710-022603	DW7860	F2S SIB
B Board	REV 05	710-023787	DW7589	NEO PMB
SIB F2S 1/0	REV 04	710-022603	DW4820	F2S SIB
B Board	REV 05	710-023787	DW8510	NEO PMB
SIB F2S 1/2	REV 05	710-022603	DW7849	F2S SIB
B Board	REV 05	710-023787	DW7525	NEO PMB
SIB F2S 1/4	REV 05	710-022603	DW7927	F2S SIB
B Board	REV 05	710-023787	DW7556	F2S SIB Mezz
SIB F2S 1/6	REV 05	710-022603	DW7866	F2S SIB
B Board	REV 05	710-023787	DW7651	NEO PMB
SIB F2S 2/0	REV 05	710-022603	DW7880	F2S SIB
B Board	REV 05	710-023787	DW7523	NEO PMB
SIB F2S 2/2	REV 05	710-022603	DW7895	F2S SIB

B Board	REV 05	710-023787	DW7591	NEO PMB
SIB F2S 2/4	REV 05	710-022603	DW7907	F2S SIB
B Board	REV 05	710-023787	DW7590	NEO PMB
SIB F2S 2/6	REV 05	710-022603	DW7785	F2S SIB
B Board	REV 05	710-023787	DW7524	NEO PMB
SIB F2S 3/0	REV 05	710-022603	DW7782	F2S SIB
B Board	REV 05	710-023787	DW7634	NEO PMB
SIB F2S 3/2	REV 05	710-022603	DW7793	F2S SIB
B Board	REV 05	710-023787	DW7548	NEO PMB
SIB F2S 3/4	REV 05	710-022603	DW7779	F2S SIB
B Board	REV 05	710-023787	DW7587	NEO PMB
SIB F2S 3/6	REV 05	710-022603	DW7930	F2S SIB
B Board	REV 05	710-023787	DW7505	NEO PMB
SIB F2S 4/0	REV 05	710-022603	DW7867	F2S SIB
B Board	REV 05	710-023787	DW7656	NEO PMB
SIB F2S 4/2	REV 05	710-022603	DW7917	F2S SIB
B Board	REV 05	710-023787	DW7640	NEO PMB
SIB F2S 4/4	REV 05	710-022603	DW7929	F2S SIB
B Board	REV 05	710-023787	DW7643	NEO PMB
SIB F2S 4/6	REV 05	710-022603	DW7870	F2S SIB
B Board	REV 05	710-023787	DW7635	NEO PMB
Fan Tray 0	REV 06	760-024497	DV7831	Front Fan Tray
Fan Tray 1	REV 06	760-024497	DV9614	Front Fan Tray
Fan Tray 2	REV 06	760-024502	DV9618	Rear Fan Tray
Fan Tray 3	REV 06	760-024502	DV9616	Rear Fan Tray
Fan Tray 4	REV 06	760-024502	DV7807	Rear Fan Tray
Fan Tray 5	REV 06	760-024502	DV7828	Rear Fan Tray

show chassis hardware (ACX7100-48L)

```
user@host> show chassis hardware
```

```
Hardware inventory:
```

Item	Version	Part number	Serial number	Description
Chassis			YW0220320039	JNP7100-48L
[ACX7100-48L]				
PSM 1	REV 04	740-085431	1ED79520221	PSU 1600W AC, Front
to				
Airflow				
Routing Engine 0	REV 04	611-112446	YY0220320013	RE-JNP-7100
CB 0	REV 05	650-113149	YW0220320039	Control Board

Back

FPC 0		BUILTIN	BUILTIN	ACX7100-48L	
PIC 0		BUILTIN	BUILTIN	MRATE- 48xSFP56 +	
6xQSF					P56-
DD					
Xcvr 0	REV 01	740-068639	1A1M31A311008	SFP28-25G-BASE-SR	
Xcvr 1	REV 01	740-030658	AA1230AZYWW	SFP+-10G-USR	
Xcvr 2	REV 01	740-031980	AP42G0C	SFP+-10G-SR	
Xcvr 3	REV 01	740-031980	ARN2FS9	SFP+-10G-SR	
Xcvr 4	REV 01	740-031980	AP4150P	SFP+-10G-SR	
Xcvr 5	REV 01	740-031980	123363A01134	SFP+-10G-SR	
Xcvr 6	REV 01	740-031980	B11E02539	SFP+-10G-SR	
Xcvr 7	REV 01	740-031980	ARQ0WRX	SFP+-10G-SR	
Xcvr 12	REV 01	740-031980	193363A00707	SFP+-10G-SR	
Xcvr 15	REV 01	740-031980	AMS15RT	SFP+-10G-SR	
Xcvr 18	REV 01	740-068639	1A1M31A5370MX	SFP28-25G-BASE-SR	
Xcvr 19	REV 01	740-068639	1A1M31A5370MS	SFP28-25G-BASE-SR	
Xcvr 21	REV 01	740-068639	1A1M31A5370MW	SFP28-25G-BASE-SR	
Xcvr 22	REV 01	740-068639	1A1M31A5370MT	SFP28-25G-BASE-SR	
Xcvr 43	REV 01	740-031980	CH09KN1H4	SFP+-10G-SR	
Xcvr 44	REV 01	740-031980	AMB0TC1	SFP+-10G-SR	
Xcvr 46	REV 01	740-031980	AP40WQN	SFP+-10G-SR	
Xcvr 47	REV 01	740-031980	APR1BCS	SFP+-10G-SR	
Xcvr 48	REV 01	740-054053	XXH0KH1	QSFP+-4X10G-SR	
Xcvr 49	REV 01	740-058734	1ECQ144605L	QSFP-100GBASE-SR4	
Xcvr 50	REV 01	740-054053	XWP0Q7D	QSFP+-4X10G-SR	
Xcvr 51	REV 01	740-058734	1ECQ144604H	QSFP-100GBASE-SR4	
Xcvr 52	REV 01	740-054053	XXH0KGC	QSFP+-4X10G-SR	
Xcvr 53	REV 01	740-058734	1ECQ144605K	QSFP-100GBASE-SR4	
Fan Tray 0				JNP7100 Fan Tray,	
Front					to
Back Airflow - AFO					
Fan Tray 1				JNP7100 Fan Tray,	
Front					to
Back Airflow - AFO					
Fan Tray 2				JNP7100 Fan Tray,	
Front					to
Back Airflow - AFO					
Fan Tray 3				JNP7100 Fan Tray,	
Front					to
Back Airflow - AFO					
Fan Tray 4				JNP7100 Fan Tray,	
Front					to
Back Airflow - AFO					

```

Fan Tray 5                               JNP7100 Fan Tray,
Front                                     to
Back Airflow - AFO

```

show chassis hardware (MX204)

The `show chassis hardware` command output does not include information about the fan tray serial number and part number of MX204 routers. This does not affect the fan's functionality.

```

user@host> show chassis hardware
Hardware inventory:Item                Version  Part number  Serial number  Description
Chassis                                CV190      JNP204 [MX204]
Routing Engine 0                       BUILTIN   BUILTIN       RE-S-1600x8
CB 0      REV 40  750-069579  CARN0542      JNP204 [MX204]
FPC 0
  PIC 0
    Xcvr 0  REV 01  740-067443  1ACP16161C7  QSFP+-40G-SR4
    Xcvr 1  REV 01  740-067443  1ACP16161E7  QSFP+-40G-SR4
    Xcvr 2  REV 01  740-067443  1ACP16161DV  QSFP+-40G-SR4
    Xcvr 3  REV 01  740-099582  1A1CQ1B6350DC  QSFP-100GBASE-SR4
  PIC 1
    Xcvr 0  REV 01  740-031980  AJJ036G      SFP+-10G-SR
    Xcvr 1  REV 01  740-031980  AN20CP8      SFP+-10G-SR
PEM 1      REV 04  740-043886  1GA4A380672  JPSU-650W-DC-AFO
Fan Tray 0                               Fan Tray, Front to Back Airflow - AFO
Fan Tray 1                               Fan Tray, Front to Back Airflow - AFO
Fan Tray 2                               Fan Tray, Front to Back Airflow -
AFO
Back Airflow - AFO

```

show chassis hardware (SRX5800)

```

user@host> show chassis hardware
Hardware inventory:
Item          Version  Part number  Serial number  Description
Chassis                                JN1080B50AFA  MX960
Midplane      REV 02  710-013698  CC6226         MX960 Backplane
Fan Extender  REV 02  710-018051  JY5235         Extended Cable Manager
FPM Board     REV 01  710-014974  JS4207         Front Panel Display

```

PEM 0	Rev 01	740-080280	1F238510008	SRX5800-UNIVERSAL-HV-PSM
PEM 1	Rev 01	740-080280	1F238510030	SRX5800-UNIVERSAL-HV-PSM
PEM 2	Rev 01	740-080280	1F238510023	SRX5800-UNIVERSAL-HV-PSM
PEM 3	Rev 01	740-080280	1F238510047	SRX5800-UNIVERSAL-HV-PSM

show chassis hardware (PTX10001-36MR) (400G ZR and 400G ZR-M optics)

```
user@host show chassis hardware
```

```
Hardware inventory:
```

Item	Version	Part number	Serial number	Description
Chassis			EM436	JNP10001-36MR [PTX10001-36MR]
PSM 0	REV 07	740-073765	1GE29391099	AC AFO 3000W PSU
Routing Engine 0	REV 08	750-100243	BCBH4788	RE-JNP10001-36MR
CB 0	REV 16	750-099260	BCBJ1424	Control Board
FPC 0		BUILTIN	BUILTIN	FPC-JNP10001-36MR
PIC 0		BUILTIN	BUILTIN	8X400GE-MR + 4X100GE-MR
Xcvr 0	REV 01	740-032986	ECX40K80042	QSFP+-40G-SR4
Xcvr 2	REV 01	740-032986	QF4804ZM	QSFP+-40G-SR4
Xcvr 3	REV 01	740-046565	QD190447	QSFP+-40G-SR4
Xcvr 4	REV 01	740-038624	S1810376855-1	QSFP+-40G-CU3M
Xcvr 5	REV 01	740-032986	ECX40K80028	QSFP+-40G-SR4
Xcvr 10	REV 01	740-131169	1T1TZFA70500D	QSFP56-DD-400G-ZR-M
PIC 1		BUILTIN	BUILTIN	8X400GE-MR + 4X100GE-MR
Xcvr 0	REV 01	740-032986	XV303SF	QSFP+-40G-SR4
Xcvr 1	REV 01	740-067442	QI1202B5	QSFP+-40G-SR4
Xcvr 2	XXXX	NON-JNPR	204053396	QSFP56-DD-400G-ZR
Xcvr 4	REV 01	740-061405	1ECQ13150KE	QSFP-100GBASE-SR4-T2
Xcvr 10	REV 01	740-131169	1T1TZFA70500C	QSFP56-DD-400G-ZR-M
PIC 2		BUILTIN	BUILTIN	8X400GE-MR + 4X100GE-MR
Xcvr 0	REV 01	740-032986	QD481959	QSFP+-40G-SR4
Xcvr 1	REV 01	740-038624	C1909242760-1	QSFP+-40G-CU3M
Xcvr 3	REV 01	740-032986	ECX02IC0146	QSFP+-40G-SR4
Xcvr 4	REV 01	740-065631	1ACS12510R3	QSFP28-100G-AOC-3M
Xcvr 5	REV 01	740-065631	1ACS1251023	QSFP28-100G-AOC-3M
Xcvr 9	REV 01	740-061405	1ECQ13150A5	QSFP-100GBASE-SR4-T2
Xcvr 10	XXXX	NON-JNPR	204053387	QSFP56-DD-400G-ZR
Xcvr 11	REV 01	740-038623	MOC14256230865	QSFP+-40G-CU1M
SIB 0		BUILTIN	BUILTIN	SIB-JNP10001-36MR
Fan Tray 0				JNP10001 Fan Tray, Front to Back
Airflow - AFO				
Fan Tray 1				JNP10001 Fan Tray, Front to Back

```

Airflow - AF0
  Fan Tray 2                               JNP10001 Fan Tray, Front to Back
Airflow - AF0
  Fan Tray 3                               JNP10001 Fan Tray, Front to Back
Airflow - AF0
  Fan Tray 4                               JNP10001 Fan Tray, Front to Back
Airflow - AF0
  Fan Tray 5                               JNP10001 Fan Tray, Front to Back
Airflow - AF0

```

show chassis hardware (MX304)

```

user@host show chassis hardware
Hardware inventory:
Item          Version  Part number  Serial number  Description
Chassis                               EU591         JNP304 [MX304]
Routing Engine 0 REV 01  750-123749  BCBZ3334      RE 2400 8C 128G
Routing Engine 1 REV 06  750-123749  BCCE2842      RE 2400 8C 128G
CB 0          REV 01  750-123404  BCBY2022      Control Board
FPC 0                               BUILTIN      BUILTIN       FPC-BUILTIN
  CPU          REV 01  750-122877  BCBX9348      JNP304 PMB
  PIC 0        REV 04  750-122718  BCBY7928      MRATE LMIC 16x100G/4x400G
    Xcvr 0     REV 01  740-065632  1FCS251700J  QSFP28-100G-AOC-5M
    Xcvr 3     REV 01  740-058734  1ACQ113404W  QSFP-100GBASE-SR4
    Xcvr 4     REV01  740-061002  LEO15180024  QSFP28-100G-CU5M
    Xcvr 5     REV 01  740-061405  1ECQ15200A9  QSFP-100G-SR4-T2
    Xcvr 7     REV 01  740-061405  1ECQ151819K  QSFP-100G-SR4-T2
    Xcvr 8     REV 01  740-058734  1ACQ11470MW  QSFP-100GBASE-SR4
    Xcvr 12    REV 01  740-065630  1FCS044402M  QSFP28-100G-AOC-1M
  PIC 1        REV 04  750-122718  BCBY7930      MRATE LMIC 16x100G/4x400G
    Xcvr 0     REV 01  740-090165  1W1CSAA539002 QSFP56-DD-400G-AOC-3M
    Xcvr 4     REV 01  740-067443  1ACP16161CQ  QSFP+-40G-SR4
    Xcvr 12    REV 01  740-065632  1FCS2517005  QSFP28-100G-AOC-5M
    Xcvr 14    REV 01  740-061405  1F1CQ1A5201F7 QSFP-100G-SR4-T2
PEM 0          Rev 01  740-110419  1F27B040062  AC AFO 2200W Power Supply
PEM 1
Fan Tray 0     REV 02  760-126744  BCCB3869      JNP304 Fan Tray, Front to Back Airflow
Fan Tray 1     REV 02  760-126744  BCCB3870      JNP304 Fan Tray, Front to Back Airflow
Fan Tray 2     REV 01  760-126744  BCBY4493      JNP304 Fan Tray, Front to Back Airflow

```

SFB 0	REV 01	750-122847	BCBX1427	Switch Fabric Board
TIB	REV 01	750-126514	BCBX9919	Timing Interface Board

show chassis hardware (ACX7509-FPC-20Y)

```

user@host show chassis hardware
Hardware inventory:
Item          Version  Part number  Serial number  Description
FPC 5        REV 04   750-120787  CARH7889      JNP-FPC-20Y
  PIC 0
    Xcvr 0    REV 01   740-071562  1A1M3AA5480F8 SFP28-25G-BASE-LR
    Xcvr 1    REV 01   720-120775  1P1C54A628HVN SFP56-50G-DAC-3M
    Xcvr 2    REV 01   720-120775  1P1C54A629JCQ SFP56-50G-DAC-3M
    Xcvr 5    REV 01   740-031980  A55B20R       SFP+-10G-SR
    Xcvr 6    REV 01   720-120775  1P1C54A629JCS SFP56-50G-DAC-3M
    Xcvr 7    REV 01   720-120775  1P1C54A628HWR SFP56-50G-DAC-3M
    Xcvr 8    REV 01   740-068639  1A1M31A31105D SFP28-25G-BASE-SR
    Xcvr 9    REV 01   740-068639  1A1M31A31105A SFP28-25G-BASE-SR
    Xcvr 10   REV 01   720-120775  1P1C54A628HZR SFP56-50G-DAC-3M
    Xcvr 11   REV 01   720-120775  1P1C54A628J00 SFP56-50G-DAC-3M
    Xcvr 12   REV 01   720-120775  1P1C54A628HW4 SFP56-50G-DAC-3M
    Xcvr 16   REV 01   740-031980  MXA0NHJ       SFP+-10G-SR
    Xcvr 17   REV 01   740-031980  AP41HCV       SFP+-10G-SR
    Xcvr 18   REV 01   740-031980  A54BA6S       SFP+-10G-SR
    Xcvr 19   REV 01   740-031980  AP40WRE       SFP+-10G-SR

```

Release Information

Command introduced before Junos OS Release 7.4.

`models` option introduced in Junos OS Release 8.2.

`sfc` option introduced in Junos OS Release 9.6 for the TX Matrix Plus router.

Information for `disk` and `usb` introduced in Junos OS Release 15.1X53-D60 for QFX10002, QFX10008, and QFX10016 switches.

`pem` detail output added in Junos OS Release 21.4R1 for SRX5800.

NOTE: Devices and routing platforms use the basic syntax, unless otherwise listed. For example, the EX Series has an additional satellite parameter available.

RELATED DOCUMENTATION

| [show chassis power](#)

show chassis led satellite

IN THIS SECTION

- [Syntax | 577](#)
- [Description | 577](#)
- [Options | 578](#)
- [Required Privilege Level | 578](#)
- [Output Fields | 578](#)
- [Sample Output | 581](#)
- [Release Information | 582](#)

Syntax

```
show chassis led satellite [slot-id slot-id |device-alias alias-name]
```

Description

Display the status and colors of the chassis LEDs of the satellite devices in a Junos Fusion. A major alarm (red) indicates a critical error condition that requires immediate action. A minor alarm (yellow) indicates a noncritical condition that requires monitoring or maintenance. A minor alarm that is left unchecked might cause interruption in service or performance degradation.

Options

none	Display the status of the chassis status LEDs of every satellite device in the Junos Fusion.
slot-id <i>slot-id</i>	(Optional) Display the status of the chassis status LEDs of the satellite device using the specified FPC slot identifier in the Junos Fusion. The <i>slot-id</i> is the FPC slot ID number.
device-alias <i>alias-name</i>	(Optional) Display the status of the chassis status LEDs of the satellite device using the specified alias in the Junos Fusion.

Required Privilege Level

view

Output Fields

Table 22 on page 578 lists the output fields for the `show chassis led satellite` command. Output fields are listed in the approximate order in which they appear.

Table 22: show chassis led Output Fields

Field Name	Field Description
Beacon LED	<p>(Applies when QFX5100, QFX5110, and QFX5200 switches are in an satellite device role only) Indicates if the beacon feature is on or off. The beacon feature is always off in a Junos Fusion.</p> <p>The Beacon LED output maps to the ID-Identification LED state.</p> <p>For more information, see:</p> <ul style="list-style-type: none"> • Chassis Status LEDs on a QFX5100 Device • QFX5110 Chassis Status LEDs • QFX5200 Chassis Status LEDs

Table 22: show chassis led Output Fields *(Continued)*

Field Name	Field Description
System LED	<p>Indicates the state of the System (SYS) LED on the satellite device.</p> <p>For more information, see:</p> <ul style="list-style-type: none"> • Chassis Status LEDs on EX4300 Switches • Chassis Status LEDs on a QFX5100 Device • QFX5110 Chassis Status LEDs • QFX5200 Chassis Status LEDs
Master LED	<p>Indicates the state of the Primary (MST) LED on the satellite device.</p> <p>For more information, see:</p> <ul style="list-style-type: none"> • Chassis Status LEDs on EX4300 Switches • Chassis Status LEDs on a QFX5100 Device • QFX5110 Chassis Status LEDs • QFX5200 Chassis Status LEDs
Alarm LED	<p>Indicates the state of the Alarm (ALM) LED on the satellite device.</p> <p>For more information, see:</p> <ul style="list-style-type: none"> • Chassis Status LEDs on EX4300 Switches • Chassis Status LEDs on a QFX5100 Device • QFX5110 Chassis Status LEDs • QFX5200 Chassis Status LEDs

Table 22: show chassis led Output Fields *(Continued)*

Field Name	Field Description
Mgmt Port0 LED	<p>(Applies when QFX5100, QFX5110, and QFX5200 switches are in an satellite device role only) Indicates the state of the management port 0 (em0) LED status on the satellite device.</p> <p>This port is always off in a Junos Fusion.</p> <p>For more information, see:</p> <ul style="list-style-type: none"> • Management Port LEDs on a QFX5100 Device • QFX5110 Management Port LEDs • QFX5200 Management Port LEDs
Mgmt Port1 LED	<p>(Applies when QFX5100, QFX5110, and QFX5200 switches are in an satellite device role only) Indicates the state of the management port 1(em1) LED status on the satellite device.</p> <p>This port is always off in a Junos Fusion.</p> <p>For more information, see:</p> <ul style="list-style-type: none"> • Management Port LEDs on a QFX5100 Device • QFX5110 Management Port LEDs • QFX5200 Management Port LEDs
Interface	<p>The interface name on the satellite device.</p> <p>For more information, see:</p> <ul style="list-style-type: none"> • Management Port LEDs on a QFX5100 Device • QFX5110 Management Port LEDs • QFX5200 Management Port LEDs

Table 22: show chassis led Output Fields (Continued)

Field Name	Field Description
Status LED	<p>The state of the Status LED for the particular interface on the satellite device.</p> <p>For more information, see:</p> <ul style="list-style-type: none"> • <i>Network Port, Built-In QSFP+ Port, Uplink Port, and Uplink Module Port LEDs on EX4300 Switches</i> • Access Port and Uplink Port LEDs on a QFX5100 Device • QFX5110 Network Port LEDs • QFX5200 Access Port and Uplink Port LEDs
Link/Activity LED	<p>The state of the Link/Activity LED for the particular interface on the satellite device.</p> <p>For more information, see:</p> <ul style="list-style-type: none"> • <i>Network Port, Built-In QSFP+ Port, Uplink Port, and Uplink Module Port LEDs on EX4300 Switches</i> • Access Port and Uplink Port LEDs on a QFX5100 Device • QFX5110 Network Port LEDs • QFX5200 Access Port and Uplink Port LEDs

Sample Output

show chassis led satellite

```
user@aggregation-device> show chassis led satellite
```

```
LED status for: FPC 101
```

```
-----
```

```
LEDs status:
```

```
Beacon LED: OFF
```

```
System LED: GREEN
```



```

Master LED: OFF
Alarm LED : YELLOW
Mgmt Port0 LED: OFF
Mgmt Port1 LED: OFF

```

Interface	STATUS LED	LINK/ACTIVITY LED
xe-101/0/0	green	
xe-101/0/1	green	
xe-101/0/10	off	
xe-101/0/48:0	green	
xe-101/0/48:1	green	
xe-101/0/48:2	green	
xe-101/0/48:3	green	

```

LED status for: FPC 102

```

```

LEDs status:

```

```

Beacon LED: OFF
System LED: GREEN
Master LED: OFF
Alarm LED : YELLOW
Mgmt Port0 LED: OFF
Mgmt Port1 LED: OFF

```

Interface	STATUS LED	LINK/ACTIVITY LED
xe-102/0/0	green	
xe-102/0/1	green	
xe-102/0/10	off	
xe-102/0/48:0	green	
xe-102/0/48:1	green	
xe-102/0/48:2	green	
xe-102/0/48:3	green	

Release Information

Command introduced in Junos OS Release 14.2R3.

RELATED DOCUMENTATION

[Configuring Satellite Device Alarm Handling Using an Environment Monitoring Satellite Policy in a Junos Fusion](#) | 96

Understanding Junos Fusion Provider Edge Components

[Understanding Junos Fusion Enterprise Components](#)

show chassis routing-engine

IN THIS SECTION

- [Syntax](#) | 584
- [Syntax \(ACX Series, PTX Series, and MX104 Universal Routing Platforms.\)](#) | 584
- [Syntax \(EX Series Switches\)](#) | 584
- [Syntax \(QFX Series\)](#) | 584
- [Syntax \(MX Series Routers\)](#) | 584
- [Syntax \(MX204 and MX10003 Universal Routing Platforms\)](#) | 585
- [Syntax \(TX Matrix Routers\)](#) | 585
- [Syntax \(TX Matrix Plus Routers\)](#) | 585
- [Syntax \(Junos OS Evolved\)](#) | 585
- [Description](#) | 585
- [Options](#) | 585
- [Required Privilege Level](#) | 587
- [Output Fields](#) | 587
- [Sample Output](#) | 592
- [show chassis routing engine \(QFX5700 Switches\) \(Junos OS Evolved Release\)](#) | 593
- [Usage](#) | 594
- [Release Information](#) | 594

Syntax

```
show chassis routing-engine
<bios | slot>
```

Syntax (ACX Series, PTX Series, and MX104 Universal Routing Platforms.)

```
show chassis routing-engine
```

Syntax (EX Series Switches)

```
show chassis routing-engine
<slot>
<satellite [slot-id slot-id |device-alias alias-name]>
```

Syntax (QFX Series)

```
show chassis routing-engine
<interconnect-device name>
<node-device name>
<slot>
<bios>
<errors>
```

Syntax (MX Series Routers)

```
show chassis routing-engine
<all-members>
<bios | slot>
<local>
<member member-id>
<satellite [slot-id slot-id |device-alias alias-name]>
```

Syntax (MX204 and MX10003 Universal Routing Platforms)

```
show chassis routing-engine  
<slot>  
<bios>  
<errors>
```

Syntax (TX Matrix Routers)

```
show chassis routing-engine  
<bios | slot>  
<lcc number | scc>
```

Syntax (TX Matrix Plus Routers)

```
show chassis routing-engine  
<bios | slot>  
<lcc number | sfc number>
```

Syntax (Junos OS Evolved)

```
show chassis routing-engine  
<slot>  
<bios>  
<hard-disk-test>
```

Description

Display the status of the Routing Engine.

Options

none Display information about one or more Routing Engines. On a TX Matrix router, display information about all Routing Engines on the TX Matrix router and its

attached T640 routers. On a TX Matrix Plus router, display information about all Routing Engines on the TX Matrix Plus router and its attached routers.

all-members	(MX Series routers only) (Optional) Display Routing Engine information for all members of the Virtual Chassis configuration.
bios	(Optional) Display the (BIOS) firmware version.
errors	(Optional) Display routing engine errors.
hard-disk-test	(Junos OS Evolved only) (Optional) Display the health of the hard disk. Use <code>disk /dev/disk-name</code> status to display the status of a particular disk.
interconnect-device <i>number</i>	(QFabric systems only) (Optional) Display Routing Engine information for a specified Interconnect device.
lcc <i>number</i>	<p>(TX Matrix and TX Matrix Plus routers only) (Optional) On a TX Matrix router, display Routing Engine information for a specified T640 router (line-card chassis) that is connected to the TX Matrix router. On a TX Matrix Plus router, display Routing Engine information for a specified router (line-card chassis) that is connected to the TX Matrix Plus router.</p> <p>Replace <i>number</i> with the following values depending on the LCC configuration:</p> <ul style="list-style-type: none"> • 0 through 3, when T640 routers are connected to a TX Matrix router in a routing matrix. • 0 through 3, when T1600 routers are connected to a TX Matrix Plus router in a routing matrix. • 0 through 7, when T1600 routers are connected to a TX Matrix Plus router with 3D SIBs in a routing matrix. • 0, 2, 4, or 6, when T4000 routers are connected to a TX Matrix Plus router with 3D SIBs in a routing matrix.
local	(MX Series routers only) (Optional) Display Routing Engine information for the local Virtual Chassis member.
member <i>member-id</i>	(MX Series routers only) (Optional) Display Routing Engine information for the specified member of the Virtual Chassis configuration. For an MX Series Virtual Chassis, replace <i>member-id</i> with a value of 0 or 1.
node-device <i>number</i>	(QFabric systems only) (Optional) Display Routing Engine information for a specified Node device.

satellite [slot-id slot-id device-alias alias-name]	(Junos Fusion only) (Optional) Display Routing Engine information for the specified satellite device in a Junos Fusion, or for all satellite devices in the Junos Fusion if no satellite devices are specified.
scc	(TX Matrix routers only) (Optional) Display Routing Engine information for the TX Matrix router (switch-card chassis).
sfc number	(TX Matrix Plus routers only) (Optional) Display Routing Engine information for the TX Matrix Plus router (or switch-fabric chassis). Replace <i>number</i> with 0.
slot	(Systems with multiple Routing Engines) (Optional) Display information for an individual Routing Engine. Replace <i>slot</i> with 0 or 1. For QFX3500 switches, there is only one Routing Engine, so you do not need to specify the slot number.

Required Privilege Level

view

Output Fields

[Table 23 on page 587](#) lists the output fields for the `show chassis routing-engine` command. Output fields are listed in the approximate order in which they appear.

Table 23: show chassis routing-engine Output Fields

Field Name	Field Description
Slot	(Systems with single and multiple Routing Engines) Slot number.
Current state	(Systems with multiple Routing Engines) Current state of the Routing Engine: Master, Backup, or Disabled.
Election priority	(Systems with multiple Routing Engines) Election priority for the Routing Engine: Master or Backup.
Temperature	Temperature of the air flowing past the Routing Engine.
CPU Temperature	Temperature of the CPU.

Table 23: show chassis routing-engine Output Fields (Continued)

Field Name	Field Description
DRAM	<p>Total DRAM available to the Routing Engine's processor.</p> <p>NOTE: When the chassis has two Routing Engines, the amount of DRAM should be the same on both. A DRAM size mismatch error can result when the Routing Engines have different amounts of DRAM.</p> <p>Starting with Junos OS Release 12.3R1, the DRAM field displays both available memory and installed memory.</p>
Memory utilization	<p>Percentage of Routing Engine memory being used.</p> <p>NOTE: For platforms running Junos OS with upgraded FreeBSD, the way memory utilization is calculated has changed. Starting in Junos OS Release 15.1R1, inactive memory is no longer included in calculating memory utilization. Inactive memory is considered as free. The value for used memory decreases and results in more memory to be available for other processes. For platforms that run Junos OS with upgraded FreeBSD, see Release Information for Junos OS with Upgraded FreeBSD.</p>
CPU utilization	<p>Information about the Routing Engine's CPU utilization:</p> <ul style="list-style-type: none"> • User—Percentage of CPU time being used by user processes. • Background—Percentage of CPU time being used by background processes. • Kernel—Percentage of CPU time being used by kernel processes. • Interrupt—Percentage of CPU time being used by interrupts. • Idle—Percentage of CPU time that is idle.
5 sec CPU Utilization	<p>Information about the Routing Engine's CPU utilization in the past 5 seconds:</p> <ul style="list-style-type: none"> • User—Percentage of CPU time being used by user processes. • Background—Percentage of CPU time being used by background processes. • Kernel—Percentage of CPU time being used by kernel processes. • Interrupt—Percentage of CPU time being used by interrupts. • Idle—Percentage of CPU time that is idle.

Table 23: show chassis routing-engine Output Fields (Continued)

Field Name	Field Description
1 min CPU Utilization	<p>Information about the Routing Engine's CPU utilization in the past 1 minute:</p> <ul style="list-style-type: none"> • User—Percentage of CPU time being used by user processes. • Background—Percentage of CPU time being used by background processes. • Kernel—Percentage of CPU time being used by kernel processes. • Interrupt—Percentage of CPU time being used by interrupts. • Idle—Percentage of CPU time that is idle.
5 min CPU Utilization	<p>Information about the Routing Engine's CPU utilization in the past 5 minutes:</p> <ul style="list-style-type: none"> • User—Percentage of CPU time being used by user processes. • Background—Percentage of CPU time being used by background processes. • Kernel—Percentage of CPU time being used by kernel processes. • Interrupt—Percentage of CPU time being used by interrupts. • Idle—Percentage of CPU time that is idle.
15 min CPU Utilization	<p>Information about the Routing Engine's CPU utilization in the past 15 minutes:</p> <ul style="list-style-type: none"> • User—Percentage of CPU time being used by user processes. • Background—Percentage of CPU time being used by background processes. • Kernel—Percentage of CPU time being used by kernel processes. • Interrupt—Percentage of CPU time being used by interrupts. • Idle—Percentage of CPU time that is idle.
Model	Routing Engine model number.
Serial ID	(Systems with multiple Routing Engines) Identification number of the Routing Engine in this slot.

Table 23: show chassis routing-engine Output Fields (Continued)

Field Name	Field Description
Start time	Time at which the Routing Engine started running.
Uptime	How long the Routing Engine has been running.
Routing Engine BIOS Version	BIOS version being run by the Routing Engine.

Table 23: show chassis routing-engine Output Fields (Continued)

Field Name	Field Description
Last reboot reason	<p data-bbox="483 363 824 390">Reason for last reboot, including:</p> <ul style="list-style-type: none"> <li data-bbox="483 426 1451 636">• power cycle/failure—Halt of the Routing Engine using the halt command, powering down using the power button on the chassis or any other method (such as removal of the control board or Routing Engine), and then powering back the Routing Engine. A halt of the operating system also occurs if you enter the request system halt command. You can enter this command to halt the system operations on the chassis or specific Routing Engines. To restart the software, press any key on the keyboard. <li data-bbox="483 674 1451 806">• watchdog—Reboot due to a hardware watchdog. A watchdog is a hardware monitoring process that examines the health and performance of the router to enable the device to recover from failures. A watchdog checks for problems at certain intervals, and reboots the routing engine if a problem is encountered. <li data-bbox="483 844 1451 909">• reset-button reset—(Not available on the EX Series switch) Reboot due to pressing of the reset button on the Routing Engine. <li data-bbox="483 947 1451 1079">• power-button hard power off—Reboot due to pressing of the power button on the chassis. A powering down of the software also occurs if you enter the request system power-off command. You can enter this command to power down the chassis or specific Routing Engines; you can then restart the software. <li data-bbox="483 1117 1247 1144">• misc hardware reason—Reboot due to miscellaneous hardware reasons. <li data-bbox="483 1182 1451 1247">• thermal shutdown—Reboot due to the router or switch reaching a critical temperature at which point it is unsafe to continue operations. <li data-bbox="483 1285 1328 1312">• hard disk failure—Reboot due to a hard disk or solid-state drive (SSD) failure. <li data-bbox="483 1350 1154 1377">• reset from debugger—Reboot due to reset from the debugger. <li data-bbox="483 1415 1451 1591">• chassis control reset—Restart the chassis process that manages PICs, FPCs, and other hardware components. The chassis control module that runs the Routing Engine performs management and monitoring functions, and it provides a single access point for operational and maintenance functions. A reset of the chassis management process occurs when you enter the restart chassis-control command. <li data-bbox="483 1629 1235 1656">• bios auto recovery reset—Reboot due to a BIOS auto-recovery reset. <li data-bbox="483 1694 1198 1722">• could not be determined—Reboot due to an undetermined reason.

Table 23: show chassis routing-engine Output Fields (Continued)

Field Name	Field Description
	<ul style="list-style-type: none"> • Router rebooted after a normal shutdown—Reboot due to a normal shutdown. This reason is displayed if the Routing Engine is powered down by pushing and holding the online/offline button on the Routing Engine faceplate for 30 seconds, and then powered back. A reboot of the software also occurs if you enter the request system reboot command. You can enter this command to reboot the chassis or specific Routing Engines. • Low battery detected This reason is displayed if the Routing Engine is powered down due to detection of low battery and powered back when battery is charged. • Catastrophic error This reason is displayed if the Routing Engine is powered down due to catastrophic error (for example, link failure between FPC line card and PFE(packet forwarding engine)) and powered back. <p>QFX5700 displays the following additional reboot reasons:</p> <ul style="list-style-type: none"> • FPGA reset Reboot due to FPGA reset. • MSMI error/hw misc Reboot due to hardware MSMI (Microsoft Mail Connector interchange) Service Returned Service-Specific error. • swizzle reset Reboot due to swizzle reset, power off and turning back on. • PCH cold reset Reboot due to complete removal of power and restart of Intel PCH (Platform Controller Hub). • software reboot Reboot of system due to software reboot process. • Straight to s5 reset Reboot due to system in S5 state and does not retain memory state. • iTCO watchdog Linux TCO hardware watchdog reboots the system automatically when there is a systems pause.
Load averages	Routing Engine load averages for the last 1, 5, and 15 minutes.

Sample Output

The sample outputs for show chassis routing engine are as follows:

show chassis routing engine (QFX5700 Switches) (Junos OS Evolved Release)

```
user@switch> show chassis routing-engine
Routing Engine status:
Slot 0:
Current state      Master
Election priority  Master
Temperature        35 degrees C / 95 degrees F
CPU temperature    39 degrees C / 102 degrees F
DRAM               25825 MB (31566 MB installed)
Memory utilization 18 percent
5 sec CPU utilization:
User               2 percent
Background         0 percent
Kernel            2 percent
Interrupt          0 percent
Idle               94 percent
1 min CPU utilization:
User               2 percent
Background         0 percent
Kernel            2 percent
Interrupt          0 percent
Idle               94 percent
5 min CPU utilization:
User               2 percent
Background         0 percent
Kernel            2 percent
Interrupt          0 percent
Idle               94 percent
15 min CPU utilization:
User               2 percent
Background         0 percent
Kernel            2 percent
Interrupt          0 percent
Idle               94 percent
Model              QFX5700-RE
Serial ID          BUILTIN
Start time 2021-06-09 02:50:08 PDT
Uptime 42 minutes, 48 seconds
Load averages: 1 minute 5 minute 15 minute
```

```
1.48 1.71 1.83
Last reboot reason      power cycle
```

Usage

The `show chassis routing-engine` and `show chassis feb` commands can be used to find the memory allocated for each RE (Routing Engine) and Packet Forwarding Engine components.

Release Information

Command introduced before Junos OS Release 7.4.

`sfc` option introduced in Junos OS Release in 9.6 for the TX Matrix Plus router.

5 sec CPU Utilization, 1 min CPU Utilization, 5 min CPU Utilization, and 15 min CPU Utilization output fields introduced in Junos OS Release 11.3R1.

`satellite` option introduced in Junos OS Release 14.2R3.

RELATED DOCUMENTATION

[request chassis routing-engine master](#)

[Configuring Routing Engine Redundancy](#)

[Switching the Global Primary and Backup Roles in a Virtual Chassis Configuration](#)

No Link Title

show chassis satellite

IN THIS SECTION

- [Syntax | 595](#)
- [Description | 595](#)
- [Options | 595](#)
- [Required Privilege Level | 596](#)
- [Output Fields | 596](#)

- Sample Output | 604
- Sample Output | 605
- Sample Output | 606
- Sample Output | 606
- Release Information | 610

Syntax

```
show chassis satellite
[device-alias device-alias | fpc-slot fpc-slot | cluster cluster-name]
[brief | detail | extensive | terse]
<since time>
```

Description

Display the status of the satellite device connections in a Junos Fusion.

Options

none	(Same as brief) Display satellite device connection information
device-alias <i>device-alias</i>	(Optional) Display satellite device connection information for the satellite device using the specified device alias only.
fpc-slot <i>fpc-slot</i>	(Optional) Display satellite device connection information for the satellite device using the specified FPC slot number only.
cluster <i>cluster-name</i>	(Optional) Display satellite device connection information for the satellite devices in the specified satellite device cluster only.
brief detail extensive terse	(Optional) Display the specified level of output.
since <i>time</i>	(Optional) Display the satellite devices that have been added to the Junos Fusion on or after a certain date or time, in <i>YYYY-MM-DD.HH:MM:SS</i> format.

To display all satellite devices added since a specified date, enter the specific date. For instance, to display all satellite devices added on or after December 22nd, 2015, enter **2015-12-22** as the *time*.

To display all satellite devices added since a specified time, enter the specific date and time. For instance, to display all satellite devices added on or after 11:01AM on December 22nd, 2015, enter **2015-12-22.11:01:00** as the *time*.

Required Privilege Level

view

Output Fields

[Table 24 on page 596](#) lists the output fields for the `show chassis satellite` command. Output fields are listed in the approximate order in which they appear.

Table 24: show chassis satellite Output Fields

Field Name	Field Description	Level of Output
Fields for Interface		
Alias	The satellite device's alias. The satellite device's alias is configured using the set chassis satellite-management fpc slot-id alias alias statement.	brief extensive none
Slot	The slot number of the satellite device. The slot number can be configured using the set chassis satellite-management fpc slot-id statement..	brief terse extensive none

Table 24: show chassis satellite Output Fields (Continued)

Field Name	Field Description	Level of Output
Device State	<p>The state of the satellite device within the Junos Fusion.</p> <p>The most common device states:</p> <ul style="list-style-type: none"> • Online—the satellite device is online and active. This is the satellite device state during normal operating procedure. • Offline—the satellite device is offline and not detected. This state is typically seen when the satellite device has been disconnected from the aggregation device, or when all cascade or uplink ports connecting the satellite device to the aggregation device are down. • Present—the satellite device is recognized by the aggregation device, but is not online. This state is typically seen before a satellite device goes online, or while satellite device configuration is in progress or finalizing. • Rebooting—the satellite device is rebooting. • Disable—the satellite device has been disabled. • Misconfig—the satellite device is not properly configured. This state is typically seen when the system ID, cascade port, or FPC slot ID defined for the satellite device has a misconfiguration. • Miswire—the satellite device is miswired. This state is typically seen when a satellite device is wired to two aggregation devices but is not configured for multihoming. Use show chassis satellite detail to gather more information on the issue when the device state is Miswire. <p>Other less common device states include:</p> <ul style="list-style-type: none"> • ModeChanging—the device is converting from a standalone device to a satellite device, or from a satellite device to a standalone device. 	<p>brief terse extensive none</p>

Table 24: show chassis satellite Output Fields (Continued)

Field Name	Field Description	Level of Output
	<ul style="list-style-type: none"> • ModeChangeFail—the mode change operation failed. • MinorUpgradeOn—A minor satellite software upgrade is in progress. • MajorUpgradeOn—A major satellite software upgrade is in progress. • Upgrade-pending—the satellite device is waiting for a satellite software upgrade. • ProvSessionDn—the provisioning session is down. • ReconcileState—the satellite provisioning daemon has restarted and is reconciling the satellite device state. 	
Cascade Ports	<p>The cascade port or ports.</p> <p>A cascade port is a port on the aggregation device that connects to a satellite device in a Junos Fusion.</p>	<p>brief extensive none</p>

Table 24: show chassis satellite Output Fields (Continued)

Field Name	Field Description	Level of Output
Port State	<p>The state of the cascade port on the aggregation device.</p> <p>Port states include:</p> <ul style="list-style-type: none"> • online—the cascade port is online and active. This is the port state during normal operating procedure. • txUpRxDn—Tx or Rx forwarding is disabled on the cascade port. This state is often seen when a second aggregation device is added to a Junos Fusion topology, and the devices in the Junos Fusion are synchronizing to the new topology. • miswire—the cascade port is miswired. This state is typically seen when a satellite device is interconnected to two aggregation devices but multihoming is not configured. Use show chassis satellite detail to gather more information on the issue when the device state is Miswire. • present—The cascade port recognized the satellite device and is up. • misconfig—the cascade port is assigned, but this interface is not working correctly due to a misconfiguration. • down—the cascade port is down. • offline—the satellite device was previously recognized from this interface, but is no longer present. • absent—the cascade port is configured but no satellite device is detected on the interface. 	<p>brief extensive none</p>

Table 24: show chassis satellite Output Fields (Continued)

Field Name	Field Description	Level of Output
Extended Ports Total	<p>The total number of extended ports on the satellite device.</p> <p>An extended port is a network-facing port on the satellite device that sends and receives network traffic for the Junos Fusion.</p>	<p>brief</p> <p>none</p> <p>terse</p>
Extended Ports Up	The number of active extended ports.	<p>brief</p> <p>none</p> <p>terse</p>
Model	The hardware model of the satellite device.	terse
Version	The version of satellite device software running on the satellite device.	terse
Satellite Alias	<p>The satellite device's alias.</p> <p>The satellite device's alias is configured using the set chassis satellite-management fpc slot-id alias alias statement.</p>	detail
FPC slot	<p>The FPC slot number of the satellite device.</p> <p>The slot number can be configured using the set chassis satellite-management fpc slot-id statement.</p>	detail
Operational State	<p>The operational state of the satellite device.</p> <p>The state UFDDown indicates that uplink failure detection disabled the satellite device's extended ports due to an uplink port failure.</p>	detail
Product Model	The hardware model of the satellite device.	detail

Table 24: show chassis satellite Output Fields (Continued)

Field Name	Field Description	Level of Output
Product Family	The product family of the satellite device.	detail
Serial number	The serial number of the satellite device.	detail
System ID	The system ID of the satellite device. The system ID is also the satellite device's MAC address.	detail
Software package version	The satellite software version running on the satellite device.	detail
Host software version	The host operating system software version running on the satellite device.	detail
Management Address	<p>The management IP address of the satellite device.</p> <p>This management IP address belongs to an internal routing instance. This management address is assigned by the control plane internally based on FPC slot ID and is used for the control plane traffic between the aggregation device and satellite device.</p> <p>All management in a Junos Fusion should be done through the aggregation device. The management IP address of the satellite device is useful for debugging purposes by expert users only.</p>	detail
UFD config state	Uplink failure detection configuration state.	detail
Minimum link	Uplink failure detection minimum active uplink port setting.	detail

Table 24: show chassis satellite Output Fields (Continued)

Field Name	Field Description	Level of Output
Holdddown timer (seconds)	Uplink failure detection holdddown timer setting, in seconds.	detail
UFD operational state	Uplink failure detection operational state.	detail
Candidate uplink interfaces (pic/port)	Uplink failure detection candidate uplink interfaces.	detail
Extended Ports	The number of extended ports for the satellite device. The number on the left is the total number of extended ports, and the number on the right is the total number of extended ports currently in the up state.	extensive
When	The date and time of the event.	extensive
Event	The event.	extensive
Action	The actions that resulted from the event.	extensive

Fields for Cascade interfaces

Interface Name	The name of the cascade interface on the aggregation device.	detail
State	The state of the cascade interface.	detail

Table 24: show chassis satellite Output Fields (Continued)

Field Name	Field Description	Level of Output
Uplink Interface	The name of the uplink interface on the satellite device.	detail
Adjacency state	The adjacency state of the cascade to uplink interface link.	detail
Last transition	The amount of time that has passed since the last transition of the cascade to uplink interface link.	detail
Adjacency down count (Interface Name)	The number of times the cascade to uplink interface link has gone into the down state.	detail
RX Packet	The number of packets received on the cascade interface.	detail
Last received packet	The amount of time that has passed since the last packet was received on the cascade interface.	detail
Peer adjacency information	The amount of time that has passed since the last peer adjacency transition.	detail
Adjacency down count (Peer adjacency information)	The number of times the cascade to uplink interface link has gone into the down state.	detail
Last down cause	The cause of the last adjacency failure.	detail

Table 24: show chassis satellite Output Fields (Continued)

Field Name	Field Description	Level of Output
SDPD restart detected	The number of times that the satellite device protocol process has restarted.	detail

Fields for Process information

Process Name	The name of the process.	detail
PID	The process identification number of the process.	detail
State	The current state of the process.	detail
Number of restart detected	The number of times the process has restarted.	detail
Uptime	The amount of time that the process has been running.	detail

Sample Output**show chassis satellite**

```

user@aggregation-device> show chassis satellite

```

Alias	Slot	Device State	Cascade Ports	Port State	Extended Ports Total/Up
qfx5100-24q-01	100	Online	xe-0/0/1 xe-0/3/0	online	9/2
qfx5100-24q-02	101	Online	xe-0/0/2 xe-0/3/1	online	20/12
qfx5100-24q-03	102	Online	xe-0/0/3 xe-0/3/2	online	16/6
qfx5100-24q-04	103	Online	xe-0/0/4 xe-0/3/3	online	16/4
qfx5100-24q-05	104	Online	xe-0/0/5	online	13/3

			xe-0/3/4	online	
qfx5100-24q-06	105	Online	xe-0/0/6	online	24/15
			xe-0/3/5	online	
qfx5100-24q-07	106	Online	xe-0/0/7	online	24/15
			xe-0/3/6	online	
qfx5100-24q-08	107	Online	xe-0/0/8	online	21/12
			xe-0/3/7	online	
ex4300-01	109	Online	xe-1/0/1	online	49/2
ex4300-02	110	Online	xe-1/0/2	online	49/2
ex4300-03	111	Online	xe-1/0/3	online	49/2
ex4300-04	112	Online	xe-1/0/4	online	49/11
ex4300-05	113	Online	xe-1/0/5	online	49/11
ex4300-06	114	Online	xe-1/0/6	online	49/11
ex4300-07	115	Online	xe-1/0/7	online	49/11
ex4300-08	116	Online	xe-1/1/0	online	49/11
ex4300-09	117	Online	xe-1/1/1	online	49/11
ex4300-10	118	Online	xe-1/1/2	online	49/11
ex4300-11	119	Online	xe-1/1/3	online	49/11
ex4300-12	120	Online	xe-1/1/4	online	49/11
ex4300-13	121	Online	xe-1/1/5	online	49/11
ex4300-14	122	Online	xe-1/1/6	online	49/11
ex4300-15	123	Online	xe-1/1/7	online	49/11
ex4300-16	124	Online	xe-1/2/1	online	49/11
ex4300-17	125	Online	xe-1/2/2	online	49/11
ex4300-18	126	Online	xe-1/2/3	online	49/2
ex4300-19	127	Online	xe-1/2/4	online	49/1
ex4300-20	128	Online	xe-1/2/5	online	49/1
ex4300-21	129	Online	xe-1/2/6	online	49/1
ex4300-22	130	Online	xe-1/2/7	online	49/1

Sample Output

show chassis satellite device-alias

```

user@aggregation-device> show chassis satellite device-alias ex4300-22

```

Alias	Slot	Device State	Cascade Ports	Port State	Extended Ports Total/Up
ex4300-22	130	Online	xe-0/2/7	online	49/1

Sample Output

show chassis satellite fpc-slot 130

```
user@aggregation-device> show chassis satellite fpc-slot 130
```

Alias	Slot	Device	Cascade	Port	Extended Ports
ex4300-22	101	State	Ports	State	Total/Up
		Online	xe-0/0/2	online	20/12
			xe-0/3/1	online	

Sample Output

show chassis satellite terse

```
user@aggregation-device> show chassis satellite terse
```

Slot	State	Device	Model	Extended Ports	Version
				Total/Up	
101	Online	QFX5100-48S-6Q		7/7	3.0R1.1
102	Online	QFX5100-48S-6Q		7/7	3.0R1.1
103	Online	QFX5100-48S-6Q		6/5	3.0R1.1
104	Online	QFX5100-48S-6Q		14/14	3.0R1.1
105	Online	QFX5100-48S-6Q		18/18	3.0R1.1
106	Online	QFX5100-48S-6Q		17/16	3.0R1.1
107	Online	EX4300-48T		52/6	3.0R1.1
108	Online	EX4300-48T		52/15	3.0R1.1
109	Online	EX4300-48T		51/14	3.0R1.1
110	Online	EX4300-48T		51/14	3.0R1.1
111	Online	EX4300-48T		51/13	3.0R1.1
112	Online	EX4300-48T		51/12	3.0R1.1
113	Online	EX4300-48T		51/13	3.0R1.1
114	Online	QFX5100-24Q-2P		17/13	3.0R1.1

show chassis satellite detail

```
user@aggregation-device> show chassis satellite detail
```

Satellite Alias: qfx5100-48s-02
 FPC Slot: 101
 Operational State: Online

```
Product Model: QFX5100-48S-6Q
Product Family: i386
Serial number: ABC123DEF456
System id: 00:11:22:aa:bb:cc
Software package version: 3.0R1.1
Host software version: 1.0.0
Management Address: 172.16.0.101/32
Cascade interfaces:
  Interface Name: xe-0/0/2 State: online
    Uplink Interface: xe-001/0/48:0
    Adjacency state: Two-Way
    Last transition: 00:10:22
    Adjacency down count: 0
    Rx Packet: 65 Last received packet: 00:00:02
    Peer adjacency information: 00:10:22
      Adjacency down count: 3
      Last down cause: Interface Down
      SDPD restart detected: 3
  Interface Name: xe-0/2/1 State: online
    Uplink Interface: xe-001/0/48:1
    Adjacency state: Two-Way
    Last transition: 00:10:22
    Adjacency down count: 0
    Rx Packet: 64 Last received packet: 00:00:02
    Peer adjacency information: 00:10:22
      Adjacency down count: 3
      Last down cause: Interface Down
      SDPD restart detected: 3
  Interface Name: xe-2/0/0 State: online
    Uplink Interface: xe-001/0/48:2
    Adjacency state: Two-Way
    Last transition: 00:10:22
    Adjacency down count: 0
    Rx Packet: 65 Last received packet: 00:00:02
    Peer adjacency information: 00:10:22
      Adjacency down count: 3
      Last down cause: Interface Down
      SDPD restart detected: 3
  Interface Name: xe-2/1/6 State: online
    Uplink Interface: xe-001/0/48:3
    Adjacency state: Two-Way
    Last transition: 00:10:22
    Adjacency down count: 0
```

Rx Packet: 65 Last received packet: 00:00:02
Peer adjacency information: 00:10:22
Adjacency down count: 3
Last down cause: Hold timer expire
SDPD restart detected: 3

Process information:

Process Name: Provisioning PID: 6716 State: Running

Number of restart detected: 0

Uptime: 00:10:22

Process Name: PFE PID: 3194 State: Running

Number of restart detected: 0

Uptime: 00:10:22

UFD config state: Enable (persist), Minimum link: 1,
Holddown timer (seconds): 6

UFD operational state: Enable

Candidate uplink interfaces (pic/port):

1/0

1/1

1/2

1/3

2/0

2/1

2/2

2/3

Satellite Alias: qfx5100-48s-03

FPC Slot: 102

Operational State: Online

Product Model: QFX5100-48S-6Q

Product Family: i386

Serial number: ABCDEFG12345

System id: 00:11:22:aa:ba:cc

Software package version: 3.0R1.1

Host software version: 1.0.0

Management Address: 172.16.0.102/32

Cascade interfaces:

Interface Name: xe-0/0/3 State: online

Uplink Interface: xe-002/0/48:0

Adjacency state: Two-Way

Last transition: 00:10:22

Adjacency down count: 0

Rx Packet: 65 Last received packet: 00:00:02

Peer adjacency information: 00:10:22

```
Adjacency down count: 3
Last down cause: Interface Down
SDPD restart detected: 3
Interface Name: xe-0/2/2 State: online
Uplink Interface: xe-002/0/48:1
Adjacency state: Two-Way
Last transition: 00:10:22
Adjacency down count: 0
Rx Packet: 65 Last received packet: 00:00:02
Peer adjacency information: 00:10:22
Adjacency down count: 3
Last down cause: Interface Down
SDPD restart detected: 3
Interface Name: xe-2/0/1 State: online
Uplink Interface: xe-002/0/48:2
Adjacency state: Two-Way
Last transition: 00:10:22
Adjacency down count: 0
Rx Packet: 65 Last received packet: 00:00:02
Peer adjacency information: 00:10:22
Adjacency down count: 3
Last down cause: Interface Down
SDPD restart detected: 3
Interface Name: xe-2/1/7 State: online
Uplink Interface: xe-002/0/48:3
Adjacency state: Two-Way
Last transition: 00:10:22
Adjacency down count: 0
Rx Packet: 65 Last received packet: 00:00:02
Peer adjacency information: 00:10:22
Adjacency down count: 3
Last down cause: Interface Down
SDPD restart detected: 3
Process information:
Process Name: Provisioning PID: 6667 State: Running
Number of restart detected: 0
Uptime: 00:10:22
Process Name: PFE PID: 3155 State: Running
Number of restart detected: 0
Uptime: 00:10:22
<additional output removed for brevity>
```

Release Information

Command introduced in Junos OS Release 14.2R3.

RELATED DOCUMENTATION

[Configuring or Expanding a Junos Fusion Enterprise](#)

Configuring Junos Fusion Provider Edge

show chassis satellite extended-port

IN THIS SECTION

- [Syntax | 610](#)
- [Description | 610](#)
- [Options | 611](#)
- [Required Privilege Level | 611](#)
- [Output Fields | 611](#)
- [Sample Output | 613](#)
- [Release Information | 615](#)

Syntax

```
show chassis satellite extended-port interface-name
<fpc-slot fpc-slot>
<interface-name interface-name>
[brief | detail | extensive | terse]
<since time>
```

Description

Display the status of the extended ports on the satellite devices in a Junos Fusion.

The extended ports are the network-facing ports on satellite devices that send and receive network traffic for a Junos Fusion.

Options

none	(Same as brief and terse) Display extended port status information.
brief detail extensive terse	(Optional) Display the specified level of output.
fpc <i>fpc-slot</i>	Display extended port status information for the specified FPC slot only. In a Junos Fusion, one FPC slot ID is assigned to each satellite device, so you can use this option to display extended port status information for all extended ports on one satellite device.
interface-name <i>interface-name</i>	Display extended port status information for the extended port interface only.
history	Display extended port history.
statistics	Display extended port statistics.
since <i>time</i>	(Optional) Display extended port status information for the satellite devices that have been added to the Junos Fusion on or after a certain date or time, which is entered in the <i>YYYY-MM-DD.HH:MM:SS</i> format. To display extended port status information for all satellite devices added since a specified date, enter the specific date as the <i>time</i> . For instance, 2015-12-22 . To display extended port status information for all satellite devices added since a specified time, enter the specific date and time as the <i>time</i> . For instance, 2015-12-22.11:01:00 .

Required Privilege Level

view

Output Fields

[Table 25 on page 612](#) lists the output fields for the `show chassis satellite extended-port` command. Output fields are listed in the approximate order in which they appear.

Table 25: show chassis satellite extended-port Output Fields

Field Name	Field Description	Level of Output
Fields for Interface		
Name	The interface name of the extended port.	brief terse detail extensive none
State	The state of the extended port.	brief terse detail extensive none
Rx Request State	The receive request state of the extended port.	brief terse detail extensive none
Tx Request State	The transmit request state of the extended port.	brief terse detail extensive none
Admin State	The administrative state of the extended port.	brief terse detail extensive none
Op State	The operational state of the extended port.	brief terse detail extensive none

Table 25: show chassis satellite extended-port Output Fields (Continued)

Field Name	Field Description	Level of Output
IFD Idx	The internal interface index.	brief terse detail extensive none
PCID	The port's E-channel identifier (ECID), abbreviated as PCID.	brief terse detail extensive none
When	The date and time of the event.	detail extensive
Event	The event.	detail extensive
Action	The actions that resulted from the event.	detail extensive

Sample Output

show chassis satellite extended-port

```

user@aggregation-device> show chassis satellite extended-port
Legend for interface types:
  * -- Uplink interface

Name          State          Rx          Tx          Admin/Op IFD
Request State Request State State  Idx  PCID
et-100/0/2    AddComplete    None        Ready        Up/Dn  838  110
et-104/0/2    AddComplete    None        Ready        Up/Dn  813  110
et-107/0/23   AddComplete    None        Ready        Up/Up  544  194
ge-109/0/0    AddComplete    None        Ready        Up/Up  402  115
ge-109/0/1    AddComplete    None        Ready        Up/Dn  403  114

```

ge-109/0/10	AddComplete	None	Ready	Up/Dn	412	113
ge-109/0/11	AddComplete	None	Ready	Up/Dn	413	112
ge-109/0/12	AddComplete	None	Ready	Up/Dn	414	123
ge-109/0/13	AddComplete	None	Ready	Up/Dn	415	122
ge-109/0/14	AddComplete	None	Ready	Up/Dn	416	125
ge-109/0/15	AddComplete	None	Ready	Up/Dn	417	124
ge-109/0/16	AddComplete	None	Ready	Up/Dn	418	131
ge-109/0/17	AddComplete	None	Ready	Up/Dn	419	130
ge-109/0/18	AddComplete	None	Ready	Up/Dn	420	133
ge-109/0/19	AddComplete	None	Ready	Up/Dn	421	132
ge-109/0/2	AddComplete	None	Ready	Up/Dn	404	117
ge-109/0/20	AddComplete	None	Ready	Up/Dn	422	127
ge-109/0/21	AddComplete	None	Ready	Up/Dn	423	126
ge-109/0/22	AddComplete	None	Ready	Up/Dn	424	129
ge-109/0/23	AddComplete	None	Ready	Up/Dn	425	128
ge-109/0/24	AddComplete	None	Ready	Up/Dn	426	103
ge-109/0/25	AddComplete	None	Ready	Up/Dn	427	102
ge-109/0/26	AddComplete	None	Ready	Up/Dn	428	105
ge-109/0/27	AddComplete	None	Ready	Up/Dn	429	104
ge-109/0/28	AddComplete	None	Ready	Up/Dn	430	107
ge-109/0/29	AddComplete	None	Ready	Up/Dn	431	106
ge-109/0/3	AddComplete	None	Ready	Up/Dn	405	116
ge-109/0/30	AddComplete	None	Ready	Up/Dn	432	109
ge-109/0/31	AddComplete	None	Ready	Up/Dn	433	108
ge-109/0/32	AddComplete	None	Ready	Up/Dn	434	135
ge-109/0/33	AddComplete	None	Ready	Up/Dn	435	134
ge-109/0/34	AddComplete	None	Ready	Up/Dn	436	137
ge-109/0/35	AddComplete	None	Ready	Up/Dn	437	136
ge-109/0/36	AddComplete	None	Ready	Up/Dn	438	144
ge-109/0/37	AddComplete	None	Ready	Up/Dn	439	143
ge-109/0/38	AddComplete	None	Ready	Up/Dn	440	146
ge-109/0/39	AddComplete	None	Ready	Up/Dn	441	145
ge-109/0/4	AddComplete	None	Ready	Up/Dn	406	119
ge-109/0/40	AddComplete	None	Ready	Up/Dn	442	140
ge-109/0/41	AddComplete	None	Ready	Up/Dn	443	139
ge-109/0/42	AddComplete	None	Ready	Up/Dn	444	142
ge-109/0/43	AddComplete	None	Ready	Up/Dn	445	141
ge-109/0/44	AddComplete	None	Ready	Up/Dn	446	148
ge-109/0/45	AddComplete	None	Ready	Up/Dn	447	147
ge-109/0/46	AddComplete	None	Ready	Up/Dn	448	150
ge-109/0/47	AddComplete	None	Ready	Up/Dn	449	149
ge-109/0/5	AddComplete	None	Ready	Up/Dn	407	118
ge-109/0/6	AddComplete	None	Ready	Up/Dn	408	121

ge-109/0/7	AddComplete	None	Ready	Up/Dn	409	120
ge-109/0/8	AddComplete	None	Ready	Up/Dn	410	111
ge-109/0/9	AddComplete	None	Ready	Up/Dn	411	110
ge-110/0/0	AddComplete	None	Ready	Up/Up	728	115
ge-110/0/1	AddComplete	None	Ready	Up/Dn	729	114

Release Information

Command introduced in Junos OS Release 14.2R3.

RELATED DOCUMENTATION

[Configuring or Expanding a Junos Fusion Enterprise](#)

Configuring Junos Fusion Provider Edge

show chassis satellite interface

IN THIS SECTION

- [Syntax | 615](#)
- [Description | 616](#)
- [Options | 616](#)
- [Required Privilege Level | 616](#)
- [Output Fields | 616](#)
- [Sample Output | 618](#)
- [Sample Output | 622](#)
- [Release Information | 622](#)

Syntax

```
show chassis satellite interface
<interface-name>
```

```
[ brief | detail | extensive ]
<since time>
```

Description

Display the status of the cascade ports as well as the internal satellite interfaces in a Junos Fusion.

You might see **sd** interfaces in the output of this command. These are internal interfaces for the Junos Fusion.

Options

interface-name Specify the name of the interface.

none (Same as **brief**) Display aggregation device interface information.

brief | detail | extensive (Optional) Display the specified level of output.

since *time* (Optional) Display interface status information for the satellite devices that have been added to the Junos Fusion on or after a certain date or time, which is entered in the *YYYY-MM-DD.HH:MM:SS* format.

To display extended port status information for all satellite devices added since a specified date, enter the specific date as the *time*. For instance, **2015-12-22**.

To display extended port status information for all satellite devices added since a specified time, enter the specific date and time as the *time*. For instance, **2015-12-22.11:01:00**.

Required Privilege Level

view

Output Fields

[Table 26 on page 617](#) lists the output fields for the `show chassis satellite interface` command. Output fields are listed in the approximate order in which they appear.

Table 26: show chassis satellite interface Output Fields

Field Name	Field Description	Level of Output
Fields for Interface		
Interface	The interface name.	brief detail extensive none
State	The state of the interface.	brief detail extensive none
Type	The type of interface.	brief detail extensive none
DF-Role	<p>(Junos Fusion Data Center with EVPN-VXLAN architecture) The designated forwarder (DF) role:</p> <ul style="list-style-type: none"> • NA—Not applicable. • NON-DF—This aggregation device is not the designated forwarder for the satellite device • DF—This aggregation device is the designated forwarder for the satellite device. 	brief detail extensive none
Provisioned Addresses	<p>The provisioned IP addresses for the Junos Fusion.</p> <p>This information is primarily useful for debugging purposes by expert users.</p>	detail extensive

Table 26: show chassis satellite interface Output Fields (Continued)

Field Name	Field Description	Level of Output
Operational Addresses	The operational IP addresses for the Junos Fusion. This information is primarily useful for debugging purposes by expert users.	detail extensive
When	The date and time of the event.	detail extensive
Event	The event.	detail extensive
Action	The actions that resulted from the event.	detail extensive

Sample Output

show chassis satellite interface

```
user@aggregation-device> show chassis satellite interface
```

```

Interface      State      Type
-----
lo0            Up        Loopback
sd-101/0/0     Up        Satellite
sd-102/0/0     Up        Satellite
sd-103/0/0     Up        Satellite
sd-104/0/0     Up        Satellite
sd-105/0/0     Up        Satellite

```

sd-106/0/0	Up	Satellite
sd-107/0/0	Up	Satellite
sd-108/0/0	Up	Satellite
sd-109/0/0	Up	Satellite
sd-110/0/0	Up	Satellite
sd-111/0/0	Up	Satellite
sd-112/0/0	Up	Satellite
sd-113/0/0	Up	Satellite
sd-114/0/0	Up	Satellite
xe-0/0/1	Up	Cascade
xe-0/0/2	Up	Cascade
xe-0/0/3	Up	Cascade
xe-0/0/4	Up	Cascade
xe-0/0/5	Up	Cascade
xe-0/0/6	Up	Cascade
xe-0/0/7	Up	Cascade
xe-0/0/8	Up	Cascade
xe-0/0/9	Up	Cascade
xe-0/2/0	Up	Cascade
xe-0/2/1	Up	Cascade
xe-0/2/2	Up	Cascade
xe-0/2/3	Up	Cascade

xe-0/2/4	Up	Cascade
xe-0/2/5	Up	Cascade
xe-0/2/6	Up	Cascade
xe-0/2/7	Up	Cascade
xe-1/0/1	Up	Cascade
xe-1/0/2	Up	Cascade
xe-1/0/3	Up	Cascade
xe-1/2/1	Up	Cascade
xe-1/2/2	Up	Cascade
xe-1/2/3	Up	Cascade
xe-2/0/0	Up	Cascade
xe-2/0/1	Up	Cascade
xe-2/0/2	Up	Cascade
xe-2/0/3	Up	Cascade
xe-2/0/4	Up	Cascade
xe-2/0/5	Up	Cascade
xe-2/0/6	Up	Cascade
xe-2/0/7	Up	Cascade
xe-2/1/0	Up	Cascade
xe-2/1/1	Up	Cascade
xe-2/1/2	Up	Cascade

xe-2/1/3	Up	Cascade
xe-2/1/4	Up	Cascade
xe-2/1/5	Up	Cascade
xe-2/1/6	Up	Cascade
xe-2/1/7	Up	Cascade
xe-2/2/0	Up	Cascade
xe-2/2/1	Up	Cascade
xe-2/2/2	Up	Cascade
xe-2/2/3	Up	Cascade
xe-2/2/4	Up	Cascade
xe-2/2/5	Up	Cascade
xe-2/2/6	Up	Cascade
xe-2/2/7	Up	Cascade
xe-2/3/0	Up	Cascade
xe-2/3/3	Dn	Cascade
xe-2/3/4	Up	Cascade
xe-2/3/5	Up	Cascade
xe-2/3/6	Up	Cascade
xe-2/3/7	Up	Cascade

Sample Output

show chassis satellite interface (Junos Fusion Data Center with EVPN-VXLAN)

```
user@aggregation-device> show chassis satellite interface
```

Interface	State	Type	DF-Role
lo0	Up	Loopback	NA
sd-101/0/0	Up	Satellite	Non-DF
sd-102/0/0	Up	Satellite	Non-DF
sd-103/0/0	Up	Satellite	DF
xe-0/0/1	Up	Cascade	NA
xe-0/0/2	Up	Cascade	NA
xe-0/0/3	Up	Cascade	NA
xe-0/0/4	Up	Cascade	NA
xe-0/0/5	Up	Cascade	NA

Release Information

Command introduced in Junos OS Release 14.2R3.

RELATED DOCUMENTATION

[Configuring or Expanding a Junos Fusion Enterprise](#)

Configuring Junos Fusion Provider Edge

show chassis satellite neighbor

IN THIS SECTION

- [Syntax | 623](#)
- [Description | 623](#)
- [Options | 623](#)
- [Required Privilege Level | 624](#)
- [Output Fields | 624](#)
- [Sample Output | 627](#)
- [Release Information | 630](#)

Syntax

```
show chassis satellite neighbor  
[interface-name]  
[ brief | detail | extensive | terse ]  
<since time>
```

Description

Display the status of the satellite device to aggregation device links in a Junos Fusion.

Options

interface-name Specify the name of the cascade port on the aggregation device.

none (Same as **terse**) Display satellite device connection information.

brief | detail | extensive | terse (Optional) Display the specified level of output.

since *time* (Optional) Display satellite device connection information for the satellite devices that have been added to the Junos Fusion on or after a certain date or time, which is entered in the *YYYY-MM-DD.HH:MM:SS* format.

To display satellite device connection information for all satellite devices added since a specified date, enter the specific date as the *time*. For instance, **2015-12-22**.

To display satellite device connection information for all satellite devices added since a specified time, enter the specific date and time as the *time*. For instance, **2015-12-22.11:01:00**.

Required Privilege Level

view

Output Fields

[Table 27 on page 624](#) lists the output fields for the `show chassis satellite neighbor` command. Output fields are listed in the approximate order in which they appear.

Table 27: show chassis satellite neighbor Output Fields

Field Name	Field Description	Level of Output
Fields for Interface		
Interface	<p>A cascade port interface on the aggregation device in the Junos Fusion.</p> <p>A cascade port interface on an aggregation device connects to a satellite device in a Junos Fusion.</p>	brief terse detail extensive none
State	The state of the interface.	brief terse detail extensive none

Table 27: show chassis satellite neighbor Output Fields (Continued)

Field Name	Field Description	Level of Output
Port Info	<p>The uplink port interface on the satellite device.</p> <p>An uplink port interface on a satellite device connects the satellite device to an aggregation device in a Junos Fusion.</p>	brief terse detail extensive none
System Name	<p>The system name, or alias, of the satellite device.</p> <p>The satellite device's alias is configured using the set chassis satellite-management fpc slot-id alias alias statement.</p>	brief terse detail extensive none
Model	The hardware model of the satellite device.	brief terse detail extensive none
SW Version	The version of satellite software running on the satellite device.	brief terse detail extensive none
Adjacency up-down transition count	The number of times that the adjacency has transitioned between up and down.	brief detail extensive
Last transition	The last transition of the adjacency state.	brief detail extensive
Device Serial Number	The serial number of the satellite device.	brief detail extensive

Table 27: show chassis satellite neighbor Output Fields (Continued)

Field Name	Field Description	Level of Output
Chassis ID	The chassis ID of the satellite device. The chassis ID of the satellite device is the satellite's device's MAC address. The chassis ID is also specified as the system ID in some Junos Fusion configuration tasks.	brief detail extensive
Device Family Name	The device family name.	brief detail extensive
Version Sequence Number	The version sequence number.	brief detail extensive
System Description	A plain-text description of the hardware and software currently running on the satellite device.	brief detail extensive
Build date	The date and time that the satellite software was built.	brief detail extensive
Hello interval	The current hello interval configuration.	brief detail extensive
Satellite hello interval	The current satellite device hello interval configuration.	brief detail extensive
Local-end (Local assigned primary address)	The local-end cascade port IP address.	brief detail extensive

Table 27: show chassis satellite neighbor Output Fields (Continued)

Field Name	Field Description	Level of Output
Remote-end (Local assigned primary address)	The remote-end uplink port IP address.	brief detail extensive
Cause (Adjacency Down History)	The cause of the last adjacency down event.	brief detail extensive
Timestamp (Adjacency Down History)	The date and time of the last adjacency down event.	brief detail extensive
Information (Adjacency Down History)	Information related to the last adjacency down event.	brief detail extensive
When	The date and time of the event.	detail extensive
Event	The event.	detail extensive
Action	The actions that resulted from the event.	detail extensive

Sample Output

show chassis satellite neighbor

```

user@aggregation-device> show chassis satellite neighbor
Interface  State      Port Info  System Name  Model          SW Version
xe-2/3/7   Init
xe-2/3/6   Init
xe-2/3/5   Init

```

```

xe-2/3/4    Init
xe-2/3/3    Dn
xe-2/3/0    Two-Way    xe-0/2/2    ex4300-29 EX4300-48T    0.1I20150224_182
7_dc-builder
xe-2/2/7    Two-Way    xe-0/2/2    ex4300-28 EX4300-48T    0.1I20150224_182
7_dc-builder
xe-2/2/6    Two-Way    xe-0/2/2    ex4300-27 EX4300-48T    0.1I20150224_182
7_dc-builder
xe-2/2/5    Two-Way    xe-0/2/2    ex4300-26 EX4300-48T    0.1I20150224_182
7_dc-builder
xe-2/2/4    Init
xe-2/2/3    Init
xe-2/2/2    Two-Way    xe-0/0/48:3 qfx5100-48s-06 QFX5100-48S-6Q 0.1I20150224_18
27_dc-builder
xe-2/2/1    Two-Way    xe-0/0/48:3 qfx5100-48s-05 QFX5100-48S-6Q 0.1I20150224_18
27_dc-builder
xe-2/2/0    Init
xe-2/1/7    Init
xe-2/1/6    Init
xe-2/1/5    Two-Way    xe-0/0/4:2  qfx5100-24q-09 QFX5100-24Q-2P 0.1I20150224_18
27_dc-builder
xe-2/1/4    Two-Way    xe-0/2/1    ex4300-31 EX4300-48T    0.1I20150224_182
7_dc-builder
xe-2/1/3    Two-Way    xe-0/2/1    ex4300-30 EX4300-48T    0.1I20150224_182
7_dc-builder
xe-2/1/2    Two-Way    xe-0/2/1    ex4300-29 EX4300-48T    0.1I20150224_182
7_dc-builder
xe-2/1/1    Two-Way    xe-0/2/1    ex4300-28 EX4300-48T    0.1I20150224_182
7_dc-builder
xe-2/1/0    Init
xe-2/0/7    Two-Way    xe-0/2/1    ex4300-26 EX4300-48T    0.1I20150224_182
7_dc-builder
xe-2/0/6    Init
xe-2/0/5    Init
xe-2/0/4    Init
xe-2/0/3    Init
xe-2/0/2    Two-Way    xe-0/0/48:2 qfx5100-48s-04 QFX5100-48S-6Q 0.1I20150224_18
27_dc-builder
xe-2/0/1    Two-Way    xe-0/0/48:2 qfx5100-48s-03 QFX5100-48S-6Q 0.1I20150224_18
27_dc-builder
xe-2/0/0    Init
xe-1/2/3    Two-Way    xe-0/0/0:0  qfx5100-24q-09 QFX5100-24Q-2P 0.1I20150224_18
27_dc-builder

```

```

xe-1/2/2    Two-Way    xe-0/2/0      ex4300-31 EX4300-48T    0.1I20150224_182
7_dc-builder
xe-1/2/1    Two-Way    xe-0/2/0      ex4300-30 EX4300-48T    0.1I20150224_182
7_dc-builder
xe-1/0/3    Two-Way    xe-0/2/0      ex4300-29 EX4300-48T    0.1I20150224_182
7_dc-builder
xe-1/0/2    Two-Way    xe-0/2/0      ex4300-28 EX4300-48T    0.1I20150224_182
7_dc-builder
xe-1/0/1    Two-Way    xe-0/2/0      ex4300-27 EX4300-48T    0.1I20150224_182
7_dc-builder
xe-0/2/7    Two-Way    xe-0/0/0:1    qfx5100-24q-09 QFX5100-24Q-2P 0.1I20150224_18
27_dc-builder
xe-0/2/6    Init
xe-0/2/5    Init
xe-0/2/4    Two-Way    xe-0/0/48:1   qfx5100-48s-05 QFX5100-48S-6Q 0.1I20150224_18
27_dc-builder
xe-0/2/3    Two-Way    xe-0/0/48:1   qfx5100-48s-04 QFX5100-48S-6Q 0.1I20150224_18
27_dc-builder
xe-0/2/2    Two-Way    xe-0/0/48:1   qfx5100-48s-03 QFX5100-48S-6Q 0.1I20150224_18
27_dc-builder
xe-0/2/1    Init
xe-0/2/0    Init
xe-0/0/9    Two-Way    xe-0/2/0      ex4300-26 EX4300-48T    0.1I20150224_182
7_dc-builder
xe-0/0/8    Two-Way    xe-0/2/0      ex4300-25 EX4300-48T    0.1I20150224_182
7_dc-builder
xe-0/0/7    Two-Way    xe-0/0/48:0   qfx5100-48s-07 QFX5100-48S-6Q 0.1I20150224_18
27_dc-builder
xe-0/0/6    Two-Way    xe-0/0/48:0   qfx5100-48s-06 QFX5100-48S-6Q 0.1I20150224_18
27_dc-builder
xe-0/0/5    Two-Way    xe-0/0/48:0   qfx5100-48s-05 QFX5100-48S-6Q 0.1I20150224_18
27_dc-builder
xe-0/0/4    Two-Way    xe-0/0/48:0   qfx5100-48s-04 QFX5100-48S-6Q 0.1I20150224_18
27_dc-builder
xe-0/0/3    Two-Way    xe-0/0/48:0   qfx5100-48s-03 QFX5100-48S-6Q 0.1I20150224_18
27_dc-builder
xe-0/0/2    Two-Way    xe-0/0/48:0   qfx5100-48s-02 QFX5100-48S-6Q 0.1I20150224_18
27_dc-builder
xe-0/0/1    Init

```

Release Information

Command introduced in Junos OS Release 14.2R3.

RELATED DOCUMENTATION

[Configuring or Expanding a Junos Fusion Enterprise](#)

Configuring Junos Fusion Provider Edge

show chassis satellite redundancy-group

IN THIS SECTION

- [Syntax | 630](#)
- [Description | 630](#)
- [Options | 631](#)
- [Required Privilege Level | 631](#)
- [Output Fields | 631](#)
- [Sample Output | 633](#)
- [Release Information | 633](#)

Syntax

```
show chassis satellite redundancy-group  
[brief | detail | extensive | terse]  
<since time>
```

Description

Display the status of the redundancy group in a Junos Fusion.

Redundancy groups are used in a Junos Fusion to configure, monitor, and maintain a topology using two aggregation devices.

Options

none (Same as **terse** and **brief**) Display redundancy group information for the Junos Fusion.

brief | detail | extensive | terse (Optional) Display the specified level of output.

since *time* (Optional) Display redundancy group information on or after a certain date or time, in *YYYY-MM-DD.HH:MM:SS* format.

To display all output since a specified date, enter the specific date. For instance, enter **2015-12-22** as the *time*.

To display all output since a specified time, enter the specific date and time. For instance, to display all information on or after 11:01AM on December 22nd, 2015, enter **2015-12-22.11:01:00** as the *time*.

Required Privilege Level

view

Output Fields

[Table 28 on page 631](#) lists the output fields for the `show chassis satellite redundancy-groups` command. Output fields are listed in the approximate order in which they appear.

Table 28: show chassis satellite redundancy-groups Output Fields

Field Name	Field Description	Level of Output
Name	The name of the redundancy group. The redundancy group name is set using the set chassis satellite-management redundancy-groups <i>redundancy-group-name</i> statement.	none terse brief detail extensive

Table 28: show chassis satellite redundancy-groups Output Fields (Continued)

Field Name	Field Description	Level of Output
Cluster State	The cluster state.	none terse brief detail extensive
Peer Chassis ID	<p>The chassis ID of the peer chassis.</p> <p>In a Junos Fusion using redundancy groups, the peer chassis ID is the chassis ID of the other aggregation device and is required to create an interchassis link (ICL).</p> <p>The chassis ID is set using the set <i>redundancy-group-name</i> chassis-id <i>chassis-id-number</i> statement.</p>	none terse brief detail extensive
Peer Chassis SN	<p>The serial number of the peer chassis.</p> <p>In a Junos Fusion using redundancy groups, the peer chassis serial number is the serial number of the other aggregation device.</p>	none terse brief detail extensive
Device Count	The device count.	none terse brief detail extensive
When	The date and time of the event.	detail extensive

Table 28: show chassis satellite redundancy-groups Output Fields (Continued)

Field Name	Field Description	Level of Output
Event	The event.	detail extensive
Action	The actions that resulted from the event.	detail extensive

Sample Output

show chassis satellite redundancy-group

```
user@aggregation-device> show chassis satellite redundancy-group
```

Name	Cluster	Peer	Peer	Device
	State	Chassis ID	Chassis SN	Count
gr1	Online	2	DC334	143/143/150

Release Information

Command introduced in Junos OS Release 16.1R1.

RELATED DOCUMENTATION

| [Configuring or Expanding a Junos Fusion Enterprise](#) | 50

show chassis satellite redundancy-group devices

IN THIS SECTION

- [Syntax | 634](#)
- [Description | 634](#)
- [Options | 634](#)
- [Required Privilege Level | 635](#)
- [Output Fields | 635](#)
- [Sample Output | 636](#)
- [Release Information | 637](#)

Syntax

```
show chassis satellite redundancy-group devices  
[brief | detail | extensive | terse]  
<history>
```

Description

Display the status of the devices in a redundancy group in a Junos Fusion.

Redundancy groups are used in a Junos Fusion to configure, monitor, and maintain a topology using two aggregation devices.

Options

- | | |
|---|--|
| none | (Same as terse and brief) Display redundancy group device information for the Junos Fusion. |
| brief detail extensive terse | (Optional) Display the specified level of output. |
| history | (Optional) Display historical output. |

Required Privilege Level

view

Output Fields

Table 29 on page 635 lists the output fields for the `show chassis satellite redundancy-groups` command. Output fields are listed in the approximate order in which they appear.

Table 29: show chassis satellite redundancy-groups Output Fields

Field Name	Field Description	Level of Output
Cluster Name	The name of the redundancy group. The redundancy group name is set using the set chassis satellite-management redundancy-groups <i>redundancy-group-name</i> statement.	none terse brief detail extensive
Slot ID	The FPC slot ID of the satellite device.	none terse brief detail extensive
Local State	The local state of the satellite device.	none terse brief detail extensive

Table 29: show chassis satellite redundancy-groups Output Fields (Continued)

Field Name	Field Description	Level of Output
Peer State	The peer state.	none terse brief detail extensive
When	The date and time of the event.	detail extensive
Event	The event.	detail extensive
Action	The actions that resulted from the event.	detail extensive

Sample Output

show chassis satellite redundancy-group devices

```
user@aggregation-device> show chassis satellite redundancy-group devices
```

```
Cluster          Local      Peer
name            Slot-ID   State     State
gr1             100      online    online
gr1             101      online    online
gr1             102      online    online
gr1             103      not-provisioned online
gr1             104      not-provisioned online
gr1             105      not-provisioned online
gr1             106      not-provisioned online
gr1             107      not-provisioned online
```

```
gr1          108          not-provisioned online
gr1          109          not-provisioned online
```

Release Information

Command introduced in Junos OS Release 16.1R1.

RELATED DOCUMENTATION

| [Configuring or Expanding a Junos Fusion Enterprise](#) | 50

show chassis satellite software

IN THIS SECTION

- [Syntax](#) | 637
- [Description](#) | 638
- [Options](#) | 638
- [Required Privilege Level](#) | 638
- [Output Fields](#) | 638
- [Sample Output](#) | 639
- [Sample Output](#) | 639
- [Release Information](#) | 640

Syntax

```
show chassis satellite software
[ brief | detail ]
```

Description

Display information related to the satellite software in the Junos Fusion.

Options

none (Same as **brief**) Display satellite device software information.

brief | detail (Optional) Display the specified level of output.

Required Privilege Level

view

Output Fields

[Table 30 on page 638](#) lists the output fields for the `show chassis satellite neighbor` command. Output fields are listed in the approximate order in which they appear.

Table 30: show chassis satellite software Output Fields

Field Name	Field Description	Level of Output
Fields for Interface		
Version	The versions of satellite software that are installed and associated with a software upgrade group.	brief none
Platforms	The hardware platform information.	brief none
Group	The name of the assigned satellite software group or groups, if assigned.	brief none
Software Package Version	The satellite software package version.	detail
Platform	The platform type.	detail

Table 30: show chassis satellite software Output Fields (Continued)

Field Name	Field Description	Level of Output
Host Version	The host version of software for the platform.	detail
Current Groups	The name or names of the satellite software upgrade groups that are using the software package. This output only appears if the software package is associated with a satellite software upgrade group.	detail
Former Groups	The name or names of satellite software upgrade groups that were previously using the software package. This output only appears if the software package was previously associated with a satellite software upgrade group.	detail

Sample Output

show chassis satellite software

```
user@aggregation-device> show chassis satellite software
Version           Platforms        Group
3.0R1.1           i386 ppc        group0
```

Sample Output

show chassis satellite software detail

```
user@aggregation-device> show chassis satellite software detail
Software package version: 3.0R1.6
Platforms supported by package: i386 ppc arm arm563xx
Platform  Host Version  Models Supported
i386      3.0.3        QFX5100-24Q-2P
          3.0.3        QFX5100-48C-6Q
```

		QFX5100-48S-6Q
		QFX5100-48T-6Q
		QFX5100-96S-8Q
		QFX5100-48SH-6Q
		QFX5100-48TH-6Q
ppc	1.1.2	EX4300-24P
		EX4300-24T
		EX4300-48P
		EX4300-48T
		EX4300-48T-BF
		EX4300-48T-DC
		EX4300-48T-DC-BF
arm	1.0.0	EX2300-24P
		EX2300-24T-DC
		EX2300-C-12T
		EX4300-C-12P
arm563xx	1.0.0	EX3400-24P
		EX3400-24T
		EX3400-48T
		EX3400-48P
Current Groups: group1		
		group2
		group3
		group4
		group5

Release Information

Command introduced in Junos OS Release 14.2R3.

RELATED DOCUMENTATION

[Configuring or Expanding a Junos Fusion Enterprise](#)

Configuring Junos Fusion Provider Edge

show chassis satellite statistics

IN THIS SECTION

- [Syntax | 641](#)
- [Description | 641](#)
- [Options | 641](#)
- [Required Privilege Level | 642](#)
- [Output Fields | 642](#)
- [Sample Output | 643](#)
- [Sample Output | 647](#)
- [Sample Output | 647](#)
- [Release Information | 648](#)

Syntax

```
show chassis satellite statistics
<device-alias device-alias>
<fpc-slot fpc-slot>
<cluster cluster-name>
```

Description

Display statistics for satellite devices in a Junos Fusion.

Options

device-alias Display output for the specified satellite device, which is identified by the device alias, only.

fpc-slot Display output for the specified satellite device, which is identified by the FPC slot ID, only.

cluster-name Display output for the satellite devices in the specified satellite device cluster only.

Required Privilege Level

view

Output Fields

Table 31 on page 642 lists the output fields for the `show chassis satellite statistics` command. Output fields are listed in the approximate order in which they appear.

Table 31: show chassis satellite statistics Output Fields

Field Name	Field Description
Fields for Interface	
Serial Number	The serial number of the satellite device.
Slot-ID	The FPC slot ID of the satellite device.
CSP down transition count	The number of times that the Control and Status Protocol (CSP) session has gone down.
Last transition (CSP down transition count)	The last time that the Control and Status Protocol (CSP) session transitioned.
Reachability down transition count	The number of times the satellite device has been in the reachability down state.
Reachability change transition count (Reachability down transition count)	The number of times that the satellite device's reachability state has transitioned.
S/W image update count	The number of times that the satellite software has been updated on the satellite device.
Extended Port add/delete/up/down request/response	The number of times an extended port—a network-facing port on the satellite device—has been added, deleted, placed in the up position, received a down request, or received a response.

Table 31: show chassis satellite statistics Output Fields (Continued)

Field Name	Field Description
Extended Port Params change request	The number of times that an extended port—a network-facing port on the satellite device—has had a change request.
Extended Port up/down operational state transition	The number of times that an extended port—a network-facing port on the satellite device—has had an operational state transition to up or down.
Rx sync complete	The number of times the receive synchronization state has been completed.
Uplink ready rx count	The number of times the uplink port—the port on the satellite device that connects to the aggregation device—has been placed in the ready-to-receive state.
Uplink ready tx count	The number of times the uplink port—the port on the satellite device that connects to the aggregation device—has been placed in the ready-to-transmit state.

Sample Output

show chassis satellite statistics

```

user@aggregation-device> show chassis satellite statistics
Serial Number: TA3714160468 Slot-ID: 101
  CSP down transition count: 0 Last transition: 05:23:56
  Reachability down transition count: 0
  Reachability change transition count: 4 Last transition: 05:23:16
  S/W image update count: 0
  Extended Port add/delete/up/down request/response: 7/0/7/2 7/0/7/2
  Extended Port Params change request: 0
  Extended Port up/down operational state transition: 7/0
  Rx sync complete: 1
  Uplink ready rx count: 4
  Uplink ready tx count: 4
Serial Number: TA3714160046 Slot-ID: 102
  CSP down transition count: 0 Last transition: 05:23:55

```

Reachability down transition count: 0
Reachability change transition count: 4 Last transition: 05:23:19
S/W image update count: 0
Extended Port add/delete/up/down request/response: 7/0/7/2 7/0/7/2
Extended Port Params change request: 0
Extended Port up/down operational state transition: 7/0
Rx sync complete: 1
Uplink ready rx count: 4
Uplink ready tx count: 4
Serial Number: TA3714140404 Slot-ID: 103
CSP down transition count: 0 Last transition: 05:23:57
Reachability down transition count: 0
Reachability change transition count: 4 Last transition: 05:23:14
S/W image update count: 0
Extended Port add/delete/up/down request/response: 6/0/5/3 6/0/5/3
Extended Port Params change request: 0
Extended Port up/down operational state transition: 5/0
Rx sync complete: 1
Uplink ready rx count: 4
Uplink ready tx count: 4
Serial Number: TA3714141327 Slot-ID: 104
CSP down transition count: 0 Last transition: 05:23:57
Reachability down transition count: 0
Reachability change transition count: 4 Last transition: 05:23:15
S/W image update count: 0
Extended Port add/delete/up/down request/response: 14/0/14/2 14/0/14/2
Extended Port Params change request: 0
Extended Port up/down operational state transition: 14/0
Rx sync complete: 1
Uplink ready rx count: 4
Uplink ready tx count: 4
Serial Number: TA3714140200 Slot-ID: 105
CSP down transition count: 0 Last transition: 05:23:59
Reachability down transition count: 0
Reachability change transition count: 4 Last transition: 05:23:15
S/W image update count: 0
Extended Port add/delete/up/down request/response: 18/0/18/2 18/0/18/2
Extended Port Params change request: 6
Extended Port up/down operational state transition: 18/0
Rx sync complete: 1
Uplink ready rx count: 4
Uplink ready tx count: 4
Serial Number: TA3714140904 Slot-ID: 106

CSP down transition count: 0 Last transition: 05:23:57
Reachability down transition count: 0
Reachability change transition count: 4 Last transition: 05:23:16
S/W image update count: 0
Extended Port add/delete/up/down request/response: 17/0/16/3 17/0/16/3
Extended Port Params change request: 2
Extended Port up/down operational state transition: 16/0
Rx sync complete: 1
Uplink ready rx count: 4
Uplink ready tx count: 4

Serial Number: PE3714040197 Slot-ID: 107
CSP down transition count: 0 Last transition: 05:24:32
Reachability down transition count: 0
Reachability change transition count: 4 Last transition: 05:23:18
S/W image update count: 0
Extended Port add/delete/up/down request/response: 52/0/7/50 52/0/7/50
Extended Port Params change request: 0
Extended Port up/down operational state transition: 7/1
Rx sync complete: 1
Uplink ready rx count: 4
Uplink ready tx count: 4

Serial Number: PE3714080398 Slot-ID: 108
CSP down transition count: 0 Last transition: 05:24:32
Reachability down transition count: 0
Reachability change transition count: 4 Last transition: 05:23:18
S/W image update count: 0
Extended Port add/delete/up/down request/response: 52/0/15/40 52/0/15/40
Extended Port Params change request: 0
Extended Port up/down operational state transition: 15/0
Rx sync complete: 1
Uplink ready rx count: 4
Uplink ready tx count: 4

Serial Number: PE3714080103 Slot-ID: 109
CSP down transition count: 0 Last transition: 05:23:22
Reachability down transition count: 0
Reachability change transition count: 3 Last transition: 05:23:19
S/W image update count: 0
Extended Port add/delete/up/down request/response: 51/0/14/37 51/0/14/37
Extended Port Params change request: 51
Extended Port up/down operational state transition: 14/0
Rx sync complete: 1
Uplink ready rx count: 3
Uplink ready tx count: 3

Serial Number: PE3714090246 Slot-ID: 110

CSP down transition count: 0 Last transition: 05:23:22

Reachability down transition count: 0

Reachability change transition count: 3 Last transition: 05:23:19

S/W image update count: 0

Extended Port add/delete/up/down request/response: 51/0/14/37 51/0/14/37

Extended Port Params change request: 42

Extended Port up/down operational state transition: 14/0

Rx sync complete: 1

Uplink ready rx count: 3

Uplink ready tx count: 3

Serial Number: PE3714080417 Slot-ID: 111

CSP down transition count: 0 Last transition: 05:23:22

Reachability down transition count: 0

Reachability change transition count: 3 Last transition: 05:23:19

S/W image update count: 0

Extended Port add/delete/up/down request/response: 51/0/13/38 51/0/13/38

Extended Port Params change request: 51

Extended Port up/down operational state transition: 13/0

Rx sync complete: 1

Uplink ready rx count: 3

Uplink ready tx count: 3

Serial Number: PE3714080018 Slot-ID: 112

CSP down transition count: 0 Last transition: 05:23:22

Reachability down transition count: 0

Reachability change transition count: 2 Last transition: 05:23:18

S/W image update count: 0

Extended Port add/delete/up/down request/response: 51/0/12/39 51/0/12/39

Extended Port Params change request: 51

Extended Port up/down operational state transition: 12/0

Rx sync complete: 1

Uplink ready rx count: 2

Uplink ready tx count: 2

Serial Number: PE3714080030 Slot-ID: 113

CSP down transition count: 0 Last transition: 05:23:22

Reachability down transition count: 0

Reachability change transition count: 3 Last transition: 05:23:18

S/W image update count: 0

Extended Port add/delete/up/down request/response: 51/0/13/38 51/0/13/38

Extended Port Params change request: 51

Extended Port up/down operational state transition: 13/0

Rx sync complete: 1

Uplink ready rx count: 3

```

Uplink ready tx count: 3
Serial Number: TB3714070145 Slot-ID: 114
CSP down transition count: 0 Last transition: 05:23:58
Reachability down transition count: 0
Reachability change transition count: 4 Last transition: 05:23:15
S/W image update count: 0
Extended Port add/delete/up/down request/response: 17/0/13/7 17/0/13/7
Extended Port Params change request: 0
Extended Port up/down operational state transition: 13/0
Rx sync complete: 1
Uplink ready rx count: 4
Uplink ready tx count: 4

```

Sample Output

show chassis satellite statistics device-alias qfx5100-48s-02

```

user@aggregation-device> show chassis satellite statistics device-alias qfx5100-48s-02
Serial Number: TA3714160468 Slot-ID: 101
CSP down transition count: 0 Last transition: 05:52:44
Reachability down transition count: 0
Reachability change transition count: 4 Last transition: 05:52:04
S/W image update count: 0
Extended Port add/delete/up/down request/response: 7/0/7/2 7/0/7/2
Extended Port Params change request: 0
Extended Port up/down operational state transition: 7/0
Rx sync complete: 1
Uplink ready rx count: 4
Uplink ready tx count: 4

```

Sample Output

show chassis satellite statistics fpc-slot 101

```

user@aggregation-device> show chassis satellite statistics fpc-slot 101
Serial Number: TA3714160468 Slot-ID: 101
CSP down transition count: 0 Last transition: 05:52:44
Reachability down transition count: 0
Reachability change transition count: 4 Last transition: 05:52:04

```

```
S/W image update count: 0
Extended Port add/delete/up/down request/response: 7/0/7/2 7/0/7/2
Extended Port Params change request: 0
Extended Port up/down operational state transition: 7/0
Rx sync complete: 1
Uplink ready rx count: 4
Uplink ready tx count: 4
```

Release Information

Command introduced in Junos OS Release 14.2R3.

RELATED DOCUMENTATION

[Configuring or Expanding a Junos Fusion Enterprise](#)

Configuring Junos Fusion Provider Edge

show chassis satellite unprovision

IN THIS SECTION

- [Syntax | 649](#)
- [Description | 649](#)
- [Options | 649](#)
- [Required Privilege Level | 650](#)
- [Output Fields | 650](#)
- [Sample Output | 653](#)
- [Sample Output | 653](#)
- [Release Information | 655](#)

Syntax

```
show chassis satellite unprovision
[brief | detail | extensive]
[cluster cluster-name]
<since time>
```

Description

Display information about unprovisioned satellite devices in a Junos Fusion.

An unprovisioned satellite device in a Junos Fusion is a satellite device that is recognized by the aggregation device, but is not participating in a Junos Fusion.

No output appears when this command is entered when a Junos Fusion contains no unprovisioned satellite devices.

This command is helpful in identifying satellite devices that are not participating in a Junos Fusion due to configuration issues. Notably, a satellite device that has not been associated with an FPC ID in a Junos Fusion becomes an unprovisioned satellite device. See [Configuring Junos Fusion Provider Edge](#) or [Configuring or Expanding a Junos Fusion Enterprise](#) for information on associating an FPC ID with a Junos Fusion.

Options

- | | |
|------------------------------------|---|
| none | (Same as brief) Display unprovisioned satellite device information. |
| brief detail extensive | (Optional) Display the specified level of output. |
| cluster <i>cluster-name</i> | (Optional) Display unprovisioned satellite device information for the specified satellite device cluster only. |
| since <i>time</i> | (Optional) Display unprovisioned satellite device information for the satellite devices that have been unprovisioned from a Junos Fusion on or after a certain date or time, which is entered in the <i>YYYY-MM-DD.HH:MM:SS</i> format. |
- To display unprovisioned satellite device information for all satellite devices unprovisioned since a specified date, enter the specific date as the time as the *time*. For instance, **2015-12-22**.

To display unprovisioned satellite device information for all satellite devices added since a specified time, enter the specific date and time as the *time*. For instance, **2015-12-22.11:01:00**.

Required Privilege Level

view

Output Fields

[Table 32 on page 650](#) lists the output fields for the `show chassis satellite unprovision` command. Output fields are listed in the approximate order in which they appear.

Table 32: show chassis satellite unprovision Output Fields

Field Name	Field Description	Level of Output
System-Id	The MAC address of the satellite device.	brief extensive none
Serial-Number	The serial number of the satellite device.	brief extensive none
Device State	The device state of the unprovisioned satellite device.	brief extensive none
Cascade Ports	The cascade ports on the aggregation device that are connected to the satellite device.	brief extensive none
Port State	The port state of the cascade port.	brief extensive none
Operational State	The operational state of the satellite device.	detail

Table 32: show chassis satellite unprovision Output Fields (Continued)

Field Name	Field Description	Level of Output
Product Model	The product model of the satellite device.	detail
Product Family	The product family of the satellite device.	detail
Serial number	The serial number of the satellite device.	detail
System id	The MAC address of the satellite device.	detail
Software package version	The satellite software package version running on the satellite device.	detail
Host software version	The host software version.	detail

Fields for Cascade interfaces

Interface Name	The interface name of the cascade port on the aggregation device.	detail
State	The state of the cascade port.	detail
Uplink Interface	The uplink interface name. The uplink interface is the interface on the satellite device that connects to the aggregation device.	detail
Adjacency State	The adjacency state of the uplink interface to cascade port link.	detail
Last transition	The amount of time that has passed since the last link transition.	detail

Table 32: show chassis satellite unprovision Output Fields (Continued)

Field Name	Field Description	Level of Output
Adjacency down count	The number of times that the uplink interface to cascade port link has gone into the adjacency down count.	detail
Rx Packet	The number of received packets.	detail
Last received packet	The amount of time that has passed since the last received packet.	detail
Peer adjacency information	The amount of time that the adjacency has been active.	detail
Last down cause	The cause of the last time the adjacency went down.	detail
SDPD restart detected	The number of times that the SDPD has restarted.	detail

Fields for process information

Process Name	The name of the process.	detail
PID	The PID of the process.	detail
State	The current state of the process.	detail
Number of restart detected	The number of times that the process has restarted.	detail
Uptime	The amount of time that the process has been active.	detail
When	The date and time of the event.	extensive

Table 32: show chassis satellite unprovision Output Fields (Continued)

Field Name	Field Description	Level of Output
Event	The event.	extensive
Action	The actions that resulted from the event.	extensive

Sample Output

show chassis satellite unprovision

```

user@aggregation-device> show chassis satellite unprovision

```

System-Id	Serial-Number	Device State	Cascade Ports	Port State
AA:BB:CC:aa:bb:cc	TABCDE111111	Present	xe-0/0/1	present
			xe-0/1/2	present
AA:BB:CC:aa:bb:zz	PABCDE111111	Present	xe-0/0/2	present
			xe-0/3/2	present

Sample Output

show chassis satellite unprovision detail

```

user@aggregation-device> show chassis satellite unprovision detail
Operational State: Present
Product Model: QFX5100-48S-6Q
Product Family: i386
Serial number: TABCDE111111
System id: AA:BB:CC:aa:bb:cc
Software package version: 3.0R1
Host software version: 0.2.3
Cascade interfaces:
  Interface Name: xe-0/0/1 State: present
    Uplink Interface: xe-0/0/25
    Adjacency state: Two-Way
    Last transition: 3d 22:06:55

```



```

Adjacency down count: 0
Rx Packet: 33875 Last received packet: 00:00:09
Peer adjacency information: 3d 22:06:55
  Adjacency down count: 3
  Last down cause: TTL is 0
  SDPD restart detected: 3
Interface Name: xe-0/1/2 State: present
  Uplink Interface: xe-0/0/24
  Adjacency state: Two-Way
  Last transition: 3d 22:06:58
  Adjacency down count: 0
  Rx Packet: 33875 Last received packet: 00:00:09
  Peer adjacency information: 3d 22:06:58
    Adjacency down count: 5
    Last down cause: TTL is 0
    SDPD restart detected: 3
Process information:
  Process Name: Provisioning PID: 2488 State: Running
  Number of restart detected: 0
  Uptime: 3d 22:06:58
  Process Name: PFE PID: 2631 State: Running
  Number of restart detected: 0
  Uptime: 3d 22:06:58
Operational State: Present
Product Model: EX4300-48T
Product Family: ppc
Serial number: PABCDE111111
System id: AA:BB:CC:aa:bb:zz
Software package version: 3.0R1
Host software version: 0.2.4
Cascade interfaces:
  Interface Name: xe-0/0/2 State: present
  Uplink Interface: xe-0/2/1
  Adjacency state: Two-Way
  Last transition: 3d 22:06:56
  Adjacency down count: 0
  Rx Packet: 33876 Last received packet: 00:00:05
  Peer adjacency information: 3d 22:06:56
    Adjacency down count: 1
    Last down cause: TTL is 0
    SDPD restart detected: 2
  Interface Name: xe-0/3/2 State: present
  Uplink Interface: xe-0/2/0

```

```

Adjacency state: Two-Way
Last transition: 3d 22:06:57
Adjacency down count: 0
Rx Packet: 33876 Last received packet: 00:00:05
Peer adjacency information: 3d 22:06:57
    Adjacency down count: 3
    Last down cause: TTL is 0
    SDPD restart detected: 2
Process information:
    Process Name: Provisioning PID: 1603 State: Running
    Number of restart detected: 0
    Uptime: 3d 22:06:57
    Process Name: PFE PID: 1615 State: Running
    Number of restart detected: 0
    Uptime: 3d 22:06:57

```

Release Information

Command introduced in Junos OS Release 14.2R3.

RELATED DOCUMENTATION

[Configuring or Expanding a Junos Fusion Enterprise](#)

Configuring Junos Fusion Provider Edge

show chassis satellite upgrade-group

IN THIS SECTION

- [Syntax | 656](#)
- [Description | 656](#)
- [Options | 656](#)
- [Required Privilege Level | 657](#)
- [Output Fields | 657](#)
- [Sample Output | 658](#)

- Sample Output | 659
- Release Information | 659

Syntax

```
show chassis satellite upgrade-group
<upgrade-group-name>
[ brief | detail | extensive | terse]
```

Description

Display information about the satellite software upgrade groups for the Junos Fusion.

A satellite software upgrade group is a group of satellite devices that are updated at the same time to the same version of the satellite software. One Junos Fusion can contain multiple software upgrade groups, and multiple software upgrade groups should be configured in most Junos Fusions to avoid network downtimes during satellite software installations.

A satellite software upgrade group that contains all satellite devices in a satellite device cluster is automatically created when a satellite device cluster is configured. The software upgrade group name for these automatically created software upgrade groups is the cluster name.

Options

none (Same as **brief** and **terse**) Display satellite software upgrade group information for all satellite software upgrade groups.

brief | detail | extensive | terse (Optional) Display the specified level of output.

upgrade-group-name Display satellite software upgrade group information for the specified satellite software upgrade group only.

The satellite software upgrade group name is set using the **set chassis satellite-management upgrade-groups *upgrade-group-name*** statement for standalone satellite devices and is the cluster name for satellite device clusters.

Required Privilege Level

view

Output Fields

Table 33 on page 657 lists the output fields for the `show chassis satellite upgrade-group` command. Output fields are listed in the approximate order in which they appear.

Table 33: show chassis satellite upgrade-group Output Fields

Field Name	Field Description	Level of Output
Fields for Interface		
Group	<p>The satellite software upgrade group name.</p> <p>The satellite software upgrade group name is the name of the satellite device cluster when used with a satellite device cluster. A satellite software upgrade group with the name of the satellite device cluster is created automatically when a satellite device cluster is configured.</p> <p>The satellite software upgrade group name is set using the set chassis satellite-management upgrade-groups <i>upgrade-group-name</i> statement for standalone satellite devices.</p>	brief terse extensive none
Sw-Version	The version of satellite software associated with the satellite software upgrade group.	brief terse extensive none
Group State	The state of the satellite software upgrade group.	brief terse extensive none
Slot	The FPC slot identification number of the satellite device that is a member of the satellite software upgrade group.	brief terse detail extensive none

Table 33: show chassis satellite upgrade-group Output Fields (Continued)

Field Name	Field Description	Level of Output
Device State	The state of the satellite software for the specified member of the satellite software upgrade group. The version-in-sync output appears when the satellite device is running the satellite software version that is associated with the satellite software upgrade group.	brief terse detail extensive none
Software upgrade group	The name of the satellite software upgrade group.	detail
Software package version	The satellite software package associated with the satellite software upgrade group.	detail
Previous software package version	The satellite software package that was previously associated with the satellite software upgrade group. This output only appears if the satellite software upgrade group was previously associated with another version of satellite software.	detail

Sample Output

show chassis satellite upgrade-group

```

user@aggregation-device> show chassis satellite upgrade-group

Group          Sw-Version          Group          Device
                State              Slot          State
__ungrouped__
ex4300         3.0R1.0            in-sync       107          version-in-sync
                                                108          version-in-sync
                                                109          version-in-sync
                                                110          version-in-sync
                                                111          version-in-sync
                                                112          version-in-sync
                                                113          version-in-sync
qfx            3.0R1.0            in-sync       102          version-in-sync

```

```

103    version-in-sync
104    version-in-sync
105    version-in-sync
106    version-in-sync
114    version-in-sync

```

Sample Output

show chassis satellite upgrade-group detail

```
user@aggregation-device> show chassis satellite upgrade-group detail
```

```
Software upgrade group: ex4300
```

```
Software package version: 3.0R1.0
```

```
Previous software package version: 3.0R1.1
```

Slot	Device State
107	version-in-sync
108	version-in-sync
109	version-in-sync
110	version-in-sync
111	version-in-sync
112	version-in-sync
113	version-in-sync

```
Software upgrade group: qfx
```

```
Software package version: 3.0R1.0
```

Slot	Device State
102	version-in-sync
103	version-in-sync
104	version-in-sync
105	version-in-sync
106	version-in-sync
114	version-in-sync

Release Information

Command introduced in Junos OS Release 14.2R3.

RELATED DOCUMENTATION

[Configuring or Expanding a Junos Fusion Enterprise](#)

Configuring Junos Fusion Provider Edge

show chassis satellite-cluster

IN THIS SECTION

- [Syntax | 660](#)
- [Description | 660](#)
- [Options | 660](#)
- [Required Privilege Level | 661](#)
- [Output Fields | 661](#)
- [Sample Output | 667](#)
- [Sample Output | 667](#)
- [Release Information | 668](#)

Syntax

```
show chassis satellite-cluster
[cluster cluster-name]
[brief | detail | extensive | terse]
```

Description

Display the status of the satellite device clusters in a Junos Fusion.

Options

none (Same as **brief**) Display satellite device cluster information for satellite device clusters in the Junos Fusion.

brief | detail | extensive | terse (Optional) Display the specified level of output.

cluster *cluster-name* Display satellite device cluster information for the specified satellite device cluster only.

Required Privilege Level

view

Output Fields

[Table 34 on page 661](#) lists the output fields for the `show chassis satellite-cluster` command. Output fields are listed in the approximate order in which they appear.

Table 34: show chassis satellite-cluster Output Fields

Field Name	Field Description	Level of Output
cluster	The name of the satellite device cluster. The name of the satellite device cluster is assigned using the <code>set chassis satellite-management cluster <i>cluster-name</i></code> statement.	terse
Provision	The number of provisioned satellite devices in the specified satellite device cluster.	terse
Present	The number of present satellite devices in the specified satellite device cluster.	terse
Online	The number of online satellite devices in the specified satellite device cluster.	terse
Unprovision	The number of unprovisioned satellite devices in the specified satellite device cluster.	terse
Misconfig	The number of misconfigured satellite devices in the specified satellite device cluster.	terse

Table 34: show chassis satellite-cluster Output Fields (Continued)

Field Name	Field Description	Level of Output
Cluster Name	The name of the satellite device cluster.	none
	The name of the satellite device cluster is assigned using the set chassis satellite-management cluster <i>cluster-name</i> statement.	detail extensive
Number of devices provisioned	The number of provisioned satellite devices in the specified satellite device cluster.	none
		detail
		extensive
Number of devices present	The number of present satellite devices in the specified satellite device cluster.	none
		detail
		extensive
Number of devices unprovisioned	The number of unprovisioned satellite devices in the specified satellite device cluster.	none
		detail
		extensive
Number of devices misconfig/ miswired	The number of misconfigured or miswired satellite devices in the specified satellite device cluster.	none
		detail
		extensive
Number of devices online	The number of online satellite devices in the specified satellite device cluster.	none
		detail
		extensive
Number of devices offline	The number of offline satellite devices in the specified satellite device cluster.	none
		detail
		extensive

Table 34: show chassis satellite-cluster Output Fields (Continued)

Field Name	Field Description	Level of Output
Slot	The slot number of the satellite device. The slot number can be configured using the set chassis satellite-management fpc <i>slot-id</i> statement.	none detail extensive

Table 34: show chassis satellite-cluster Output Fields (Continued)

Field Name	Field Description	Level of Output
Device State	<p>The device state of the satellite device in the satellite device cluster.</p> <p>The most common device states:</p> <ul style="list-style-type: none"> • Online—the satellite device is online and active. This is the satellite device state during normal operating procedure. • Offline—the satellite device is offline and not detected. This state is typically seen when the satellite device has been disconnected from the aggregation device, or when all cascade or uplink ports connecting the satellite device to the aggregation device are down. • Present—the satellite device is recognized by the aggregation device. In a satellite device cluster, this state is seen during normal operation for all satellite devices that are not directly cabled to the aggregation device. • Rebooting—the satellite device is rebooting. • Disable—the satellite device has been disabled. • Misconfig—the satellite device is not properly configured. This state is typically seen when the system ID, cascade port, or FPC slot ID defined for the satellite device has a misconfiguration. • Miswire—the satellite device is miswired. This state is typically seen when a satellite device is wired to two aggregation devices but is not configured for multihoming. Use show chassis satellite detail to gather more information on the issue when the device state is Miswire. <p>Other less common device states include:</p> <ul style="list-style-type: none"> • ModeChanging—the device is converting from a standalone device to a satellite device, or from a satellite device to a standalone device. 	<p>none</p> <p>detail</p> <p>extensive</p>

Table 34: show chassis satellite-cluster Output Fields (Continued)

Field Name	Field Description	Level of Output
	<ul style="list-style-type: none"> • ModeChangeFail—the mode change operation failed. • MinorUpgradeOn—A minor satellite software upgrade is in progress. • MajorUpgradeOn—A major satellite software upgrade is in progress. • Upgrade-pending—the satellite device is waiting for a satellite software upgrade. • ProvSessionDn—the provisioning session is down. • ReconcileState—the satellite provisioning daemon has restarted and is reconciling the satellite device state. 	
Distance	<p>The distance the satellite device is away from the aggregation device.</p> <p>In this output, each hop to get from the satellite device to the aggregation device is counted as 4.</p> <p>The via output provides the slot number of the satellite device in the satellite device cluster that is directly connected to the aggregation device and passing traffic for the specified satellite device.</p>	<p>none</p> <p>detail</p> <p>extensive</p>
Local Interface	A local interface on the specified satellite device.	<p>none</p> <p>detail</p> <p>extensive</p>
Remote Interface	A remote interface on the specified satellite device.	<p>none</p> <p>detail</p> <p>extensive</p>

Table 34: show chassis satellite-cluster Output Fields (Continued)

Field Name	Field Description	Level of Output
Interface State	<p>The state of the local and remote interface connection.</p> <p>Port states include:</p> <ul style="list-style-type: none"> • online—the cascade port is online and active. This is the port state during normal operating procedure. • txUpRxDn—Tx or Rx forwarding is disabled on the cascade port. This state is often seen when a second aggregation device is added to a Junos Fusion topology, and the devices in the Junos Fusion are synchronizing to the new topology. • miswire—the cascade port is miswired. This state is typically seen when a satellite device is interconnected to two aggregation devices but multihoming is not configured. Use show chassis satellite detail to gather more information on the issue when the device state is Miswire. • present—The cascade port recognized the satellite device and is up. • misconfig—the cascade port is assigned, but this interface is not working correctly due to a misconfiguration. • down—the cascade port is down. • offline—the satellite device was previously recognized from this interface, but is no longer present. • absent—the cascade port is configured but no satellite device is detected on the interface. 	<p>none</p> <p>detail</p> <p>extensive</p>
Adj Up/Dn Count	The number of times the satellite device in the satellite device cluster has transitioned to the up or down state.	<p>detail</p> <p>extensive</p>

Table 34: show chassis satellite-cluster Output Fields (Continued)

Field Name	Field Description	Level of Output
Last Transition	The time of the last transition to the up or down state.	detail extensive
When	The date and time of the event.	extensive
Event	The event.	extensive
Action	The actions that resulted from the event.	extensive

Sample Output

show chassis satellite-cluster terse

```
user@aggregation-device> show chassis satellite-cluster terse

Cluster   Provision  Present  Online  Unprovision  Misconfig  Offline
c11       4          4        4       0            0          0
```

Sample Output

show chassis satellite-cluster

```
user@aggregation-device> show chassis satellite-cluster

Cluster Name: cluster1
  Number of devices provisioned: 4
  Number of devices present: 4
  Number of devices unprovisioned: 0
  Number of devices misconfig/miwired: 0
  Number of devices online: 4
  Number of devices offline: 0
```

Slot	Device State	Distance	Local Interface	Remote Interface	Interface State
101	Online	0	xe-101/0/0	ge-0/0/0	online
			xe-101/0/1	ge-0/0/1	online
			xe-101/0/4	xe-102/0/0	present
			xe-101/0/5	xe-102/0/1	present
102	Online	4 [via 101]	xe-102/0/0	xe-101/0/4	present
			xe-102/0/1	xe-101/0/5	present
			xe-102/0/2	xe-103/0/0	present
			xe-102/0/3	xe-103/0/1	present
103	Online	8 [via 101]	xe-103/0/0	xe-102/0/2	present
			xe-103/0/1	xe-102/0/3	present
			xe-103/0/2	xe-104/0/4	present
			xe-103/0/3	xe-104/0/5	present
104	Online	12 [via 101]	xe-104/0/4	xe-103/0/2	present
			xe-104/0/5	xe-103/0/3	present

Release Information

Command introduced in Junos OS Release 16.1R1.

RELATED DOCUMENTATION

[Configuring or Expanding a Junos Fusion Enterprise](#) | 50

show chassis satellite-cluster route

IN THIS SECTION

- [Syntax](#) | 669
- [Description](#) | 669
- [Options](#) | 669
- [Required Privilege Level](#) | 669
- [Output Fields](#) | 669
- [Sample Output](#) | 670

Syntax

```
show chassis satellite-cluster route  
[cluster cluster-name]  
[fpc-slot slot-id]
```

Description

Display information about the route to the aggregation device for a satellite device in a satellite device cluster in a Junos Fusion.

Options

cluster *cluster-name* Display route information for all satellite devices in the specified cluster.

fpc-slot *slot-id* Display route information for the satellite device using the specified FPC slot ID.

Required Privilege Level

view

Output Fields

[Table 35 on page 670](#) lists the output fields for the `show chassis satellite-cluster route` command. Output fields are listed in the approximate order in which they appear.

Table 35: show chassis satellite-cluster route Output Fields

Field Name	Field Description
Cluster Name	<p>The name of the satellite device cluster.</p> <p>The name of the satellite device cluster is assigned using the set chassis satellite-management cluster <i>cluster-name</i> statement.</p>
Slot	<p>The slot number of the satellite device.</p> <p>The slot number and the FPC ID are the same number in this context.</p>
Interface	Interface on the satellite device that is either interconnected to an aggregation device or another satellite device in the satellite device cluster.
Transit slot	The slot number of the satellite device in the satellite device cluster that is passing traffic to the aggregation device for the specified satellite device.
Distance	<p>The distance the satellite device is away from the aggregation device.</p> <p>A satellite device in a satellite device cluster that has an uplink port connection to an aggregation device has a distance of 0.</p> <p>The number given in this output counts each hop to a satellite device in the satellite device cluster as 4. For instance, a satellite device that is one aggregation device away from the satellite device with the uplink port has a distance of 4.</p> <p>The <i>via</i> output provides the slot number of the satellite device in the satellite device cluster that is directly connected to the aggregation device and passing traffic for the specified satellite device.</p>

Sample Output

show chassis satellite-cluster route

```
user@aggregation-device> show chassis satellite-cluster route
```

```
Cluster Name: cluster1
```

```
Transit
```

Slot	Interface	Slot	Distance
101	ge-0/0/1	direct	0
	ge-0/0/0	direct	0
102	ge-0/0/1	101	4
	ge-0/0/0	101	4
103	ge-0/0/1	101	8
	ge-0/0/0	101	8
104	ge-0/0/1	101	12
	ge-0/0/0	101	12

Release Information

Command introduced in Junos OS Release 16.1R1.

RELATED DOCUMENTATION

[Configuring or Expanding a Junos Fusion Enterprise](#) | 50

show chassis satellite-cluster statistics

IN THIS SECTION

- [Syntax](#) | 672
- [Description](#) | 672
- [Options](#) | 672
- [Required Privilege Level](#) | 672
- [Output Fields](#) | 672
- [Sample Output](#) | 674
- [Release Information](#) | 676

Syntax

```
show chassis satellite-cluster statistics
[cluster cluster-name]
[fpc-slot slot-id]
```

Description

Display satellite device cluster statistics for satellite devices in satellite device clusters in a Junos Fusion.

Options

cluster *cluster-name* Display satellite device cluster statistics for all satellite devices in the specified cluster.

fpc-slot *slot-id* Display satellite device cluster statistics for the satellite device using the specified FPC slot ID.

Required Privilege Level

view

Output Fields

[Table 36 on page 672](#) lists the output fields for the `show chassis satellite-cluster statistics` command. Output fields are listed in the approximate order in which they appear.

Table 36: show chassis satellite-cluster statistics Output Fields

Field Name	Field Description
Cluster Name	The name of the satellite device cluster. The name of the satellite device cluster is assigned using the <code>set chassis satellite-management cluster <i>cluster-name</i></code> statement.
FPC Slot	The FPC slot ID number of the satellite device.

Table 36: show chassis satellite-cluster statistics Output Fields (Continued)

Field Name	Field Description
Message Type	The message type.
Received	The number of times the specified message type has been received on the satellite device in the satellite device cluster.
Sent	The number of times the specified message type has been sent on the satellite device in the satellite device cluster.
Rx errors	The number of times the specified message type has experienced a receive error on the satellite device in the satellite device cluster.
Adjacency Up	The total number of Adjacency Up events on the satellite device in the satellite device cluster.
Adjacency Down	The total number of Adjacency Down events on the satellite device in the satellite device cluster.
LLDP Adjacency Up	The total number of LLDP Adjacency Up events on the satellite device in the satellite device cluster.
LLDP Adjacency Down	The total number of LLDP Adjacency Down events on the satellite device in the satellite device cluster.
SD Adjacency Up	The total number of satellite device Adjacency Up events on the satellite device in the satellite device cluster.
SD Adjacency Down	The total number of satellite device Adjacency Down events on the satellite device in the satellite device cluster.
Route Add	The total number of Route Add events on the satellite device in the satellite device cluster.

Table 36: show chassis satellite-cluster statistics Output Fields (Continued)

Field Name	Field Description
Route Change	The total number of Route change events on the satellite device in the satellite device cluster.
Route Delete	The total number of Route Delete events on the satellite device in the satellite device cluster.
Provisioned event	The total number of Provisioned events on the satellite device in the satellite device cluster.
Unprovisioned event	The total number of Unprovisioned events on the satellite device in the satellite device cluster.
Delete event	The total number of delete events on the satellite device in the satellite device cluster.
Protocol Session Up	The total number of Protocol Session Up events on the satellite device in the satellite device cluster.
Protocol Session Down	The total number of Protocol Session Down events on the satellite device in the satellite device cluster.

Sample Output

show chassis satellite-cluster statistics cluster cluster1

```
user@aggregation-device> show chassis satellite-cluster statistics cluster cluster1
```

```
Cluster Name: cluster1
```

```
FPC Slot: 101
```

Message type	Received	Sent	Rx errors
Open	0	1	0
Adjacency UP	4	0	0
Adjacency Down	2	0	0

Sync Complete	0	0	0
Provision	0	1	0
Unprovision	0	0	0
Remote SD Route	7	0	0
Mode change Request	0	0	0
Mode change Cancel	0	0	0
Set Policy	0	0	0
Reset Policy	0	0	0
Msg Ack	0	7	0
Keepalive	2568	2567	0

General Statistics:

Adjacency Up	1
Adjacency Down	0
LLDP Adjacency Up	2
LLDP Adjacency Down	0
SD Adjacency Up	2
SD Adjacency Down	0
Route Add	1
Route Change	2
Route Delete	0
Provisioned event	1
Unprovisioned event	0
Delete event	0
Protocol Session Up	1
Protocol Session Down	0

FPC Slot: 102

Message type	Received	Sent	Rx errors
Open	0	2	0
Adjacency UP	8	0	0
Adjacency Down	0	0	0
Sync Complete	0	0	0
Provision	0	2	0
Unprovision	0	0	0
Remote SD Route	0	0	0
Mode change Request	0	0	0
Mode change Cancel	0	0	0
Set Policy	0	0	0
Reset Policy	0	0	0
Msg Ack	0	0	0

```
Keepalive                2566          2568    0
```

General Statistics:

```
Adjacency Up            1
Adjacency Down          0
LLDP Adjacency Up       0
LLDP Adjacency Down     0
SD Adjacency Up         6
SD Adjacency Down       2
Route Add                2
Route Change            6
Route Delete            1
Provisioned event       1
Unprovisioned event     0
Delete event            0
Protocol Session Up     2
Protocol Session Down   1
```

Release Information

Command introduced in Junos OS Release 16.1R1.

RELATED DOCUMENTATION

[Configuring or Expanding a Junos Fusion Enterprise](#) | 50

show chassis temperature-thresholds

IN THIS SECTION

- [Syntax](#) | 677
- [Syntax \(TX Matrix Routers\)](#) | 677
- [Syntax \(TX Matrix Plus Routers\)](#) | 677
- [Syntax \(MX Series Routers\)](#) | 677

- [Syntax \(QFX Series\) | 678](#)
- [Description | 678](#)
- [Options | 678](#)
- [Required Privilege Level | 679](#)
- [Output Fields | 679](#)
- [Sample Output | 681](#)
- [Release Information | 704](#)

Syntax

```
show chassis temperature-thresholds
```

Syntax (TX Matrix Routers)

```
show chassis temperature-thresholds  
<lcc number | scc>
```

Syntax (TX Matrix Plus Routers)

```
show chassis temperature-thresholds  
<lcc number | sfc number>
```

Syntax (MX Series Routers)

```
show chassis temperature-thresholds  
<all-members>  
<local>  
<member member-id>  
<satellite [slot-id slot-ID |device-alias alias-name]>
```

Syntax (QFX Series)

```
show chassis temperature-thresholds
<interconnect-device name>
<node-device name>
```

Description

Display chassis temperature threshold settings, in degrees Celsius.

Options

none	Display the temperature threshold details.
all-members	(MX Series routers only) (Optional) Display the chassis temperature threshold settings of all member routers in the Virtual Chassis configuration.
interconnect-device <i>name</i>	(QFabric systems only) (Optional) Display the chassis temperature threshold settings of the Interconnect device.
lcc <i>number</i>	<p>(TX Matrix and TX Matrix Plus routers only) (Optional) On a TX Matrix router, display the temperature threshold details of a specified T640 router (line-card chassis) that is connected to a TX Matrix router. On a TX Matrix Plus router, display the temperature threshold details of a specified router (line-card chassis) that is connected to a TX Matrix Plus router.</p> <p>Replace <i>number</i> with the following values depending on the LCC configuration:</p> <ul style="list-style-type: none"> • 0 through 3, when T640 routers are connected to a TX Matrix router in a routing matrix. • 0 through 3, when T1600 routers are connected to a TX Matrix Plus router in a routing matrix. • 0 through 7, when T1600 routers are connected to a TX Matrix Plus router with 3D SIBs in a routing matrix. • 0, 2, 4, or 6, when T4000 routers are connected to a TX Matrix Plus router with 3D SIBs in a routing matrix.
local	(MX Series routers only) (Optional) Display the chassis temperature threshold settings of the local Virtual Chassis member.

member <i>member-id</i>	(MX Series routers only) (Optional) Display the chassis temperature threshold settings of the specified member of the Virtual Chassis configuration. Replace <i>member-id</i> with a value of 0 or 1.
node-device <i>name</i>	(QFabric systems only) (Optional) Display the chassis temperature threshold settings of the Node device.
satellite [<i>slot-id</i> <i>slot-ID</i> <i>device-id</i> <i>alias</i> <i>alias-name</i>]	(Junos Fusion only) (Optional) Display the chassis temperature threshold settings for the specified satellite device or devices in a Junos Fusion, or for all satellite devices if no satellite devices are specified.
scc	(TX Matrix routers only) (Optional) Display the temperature threshold details of the TX Matrix router (switch-card chassis).
sfc <i>number</i>	(TX Matrix Plus routers only) (Optional) On TX Matrix Plus routers, display the temperature threshold details of the TX Matrix Plus router, which is the switch-fabric chassis. Replace <i>number</i> with 0.

Required Privilege Level

view

Output Fields

[Table 37 on page 679](#) lists the output fields for the `show chassis temperature-thresholds` command. Output fields are listed in the approximate order in which they appear.

Table 37: show chassis temperature-thresholds Output Fields

Field name	Field Description
Item	Chassis component. If per FRU per slot thresholds are configured, the components about which information is displayed include the chassis, the Routing Engines, CPUs, FPCs, and FEBs. If per FRU per slot thresholds are not configured, the components about which information is displayed include the chassis and the Routing Engines.

Table 37: show chassis temperature-thresholds Output Fields (Continued)

Field name	Field Description
Fan speed	<p>NOTE: On the QFX3500 switch and QFX3600 switch, there are four fan speeds: low, medium-low, medium-high, and high. The fan speed changes at the threshold when going from a low speed to a higher speed. When the fan speed changes from a higher speed to a lower speed, the temperature changes two degrees below the threshold.</p> <p>Temperature threshold settings, in degrees Celsius, for the fans to operate at normal and high speeds.</p> <ul style="list-style-type: none"> • Normal—The fans operate at normal speed if the component is at or below this temperature and all the fans are present and functioning normally. <p>NOTE: On a TX Matrix Plus router with 3D SIBs, the threshold temperature at the XF junction is set to 70°C for Normal fan speed, which is less than or equal to 4800 RPM.</p> <ul style="list-style-type: none"> • High—The fans operate at high speed if the component has exceeded this temperature or a fan has failed or is missing. <p>NOTE: On a TX Matrix Plus router with 3D SIBs, the threshold temperature at the XF junction is set to 75°C for High fan speed, which is greater than or equal to 5000 RPM.</p> <p>NOTE: For MX480 Routers, there are three fan speeds: Low, Medium, and High.</p> <p>An alarm is not triggered until the temperature exceeds the threshold settings for a yellow alarm or a red alarm.</p>
Yellow alarm	<p>Temperature threshold settings, in degrees Celsius, that trigger a yellow alarm.</p> <ul style="list-style-type: none"> • Normal—The temperature that must be exceeded on the component to trigger a yellow alarm when the fans are running at full speed. • Bad fan—The temperature that must be exceeded on the component to trigger a yellow alarm when one or more fans have failed or are missing.
Red alarm	<p>Temperature threshold settings, in degrees Celsius, that trigger a red alarm.</p> <ul style="list-style-type: none"> • Normal—The temperature that must be exceeded on the component to trigger a red alarm when the fans are running at full speed. • Bad fan—The temperature that must be exceeded on the component to trigger a red alarm when one or more fans have failed or are missing.

Table 37: show chassis temperature-thresholds Output Fields (Continued)

Field name	Field Description
Fire Shutdown	(T4000 routers, TX Matrix Plus router with 3D SIBs, and PTX Series Packet Transport Routers only)—Temperature threshold settings, in degrees Celsius, for the network device to shut down.

Sample Output

show chassis temperature-thresholds

```
user@host> show chassis temperature-thresholds
```

Item	Fan speed (degrees C)		Yellow alarm (degrees C)		Red alarm (degrees C)	
	Normal	High	Normal	Bad fan	Normal	Bad fan
Chassis default	48	54	65	55	75	65
Routing Engine 0	70	80	95	95	110	110
Routing Engine 1	70	80	95	95	110	110
FPC 0	55	60	75	65	90	80
FPC 1	55	60	75	65	90	80
FPC 2	55	60	75	65	90	80
FPC 3	55	60	75	65	90	80
FPC 4	55	60	75	65	90	80
FPC 5	55	60	75	65	90	80
FPC 6	55	60	75	65	90	80
FPC 7	55	60	75	65	90	80
FPC 8	55	60	75	65	90	80
FPC 9	55	60	75	65	90	80
FPC 10	55	60	75	65	90	80
FPC 11	55	60	75	65	90	80

show chassis temperature-thresholds (MX150)

```
user@host> show chassis temperature-thresholds
```

Fan speed	Yellow alarm	Red alarm	Fire Shutdown
	(degrees C)	(degrees C)	(degrees C)
			(degrees C)

Item	Normal	High	Normal	Bad fan	Normal	Bad fan	Normal
FPC 0 Sensor 1	43	65	68	68	70	70	72
FPC 0 Sensor 2	43	65	68	68	70	70	72
FPC 0 Coretemp	78	94	100	100	105	105	110

show chassis temperature-thresholds (MX104 Router)

```
user@host> show chassis temperature-thresholds
```

Item	Fan speed (degrees C)		Yellow alarm (degrees C)		Red alarm (degrees C)		Fire Shutdown (degrees C)
	Normal	High	Normal	Bad fan	Normal	Bad fan	Normal
Chassis default	48	54	65	55	75	65	100
Routing Engine 0	55	80	95	95	105	100	108

show chassis temperature-thresholds (MX240, MX480, MX960 Routers with Application Services Modular Line Card)

```
user@host> show chassis temperature-thresholds
```

Item	Fan speed (degrees C)		Yellow alarm (degrees C)		Red alarm (degrees C)		Fire Shutdown (degrees C)
	Normal	High	Normal	Bad fan	Normal	Bad fan	Normal
Chassis default	48	54	65	55	75	65	100
Routing Engine 0	70	80	95	95	110	110	112
Routing Engine 1	70	80	95	95	110	110	112
FPC 0	55	60	75	65	90	80	95
FPC 1	55	60	75	65	90	80	95
FPC 2	55	60	75	65	90	80	95
FPC 4	55	60	75	65	90	80	95
FPC 5	55	60	75	65	90	80	95

show chassis temperature-thresholds (MX480 Router with MPC4E)

```
user@ host> show chassis temperature-thresholds
```

Item	Fan speed (degrees C)		Yellow alarm (degrees C)		Red alarm (degrees C)		Fire Shutdown (degrees C)
	Normal	High	Normal	Bad fan	Normal	Bad fan	Normal
Chassis default	48	54	65	55	75	65	100
Routing Engine 0	70	80	95	95	110	110	112

Routing Engine 1	70	80	95	95	110	110	112
FPC 2	55	60	75	65	95	80	100
FPC 3	55	60	75	65	95	80	100
FPC 4	55	60	75	65	90	80	95

show chassis temperature-thresholds (MX2010 Router with MPC7E, MPC8E, and MPC9E)

```
user@ host> show chassis temperature-thresholds
```

Shutdown (degrees C) Item	Fan speed		Yellow alarm		Red alarm		Fire
	(degrees C)		(degrees C)		(degrees C)		
	Normal	High	Normal	Bad fan	Normal	Bad fan	Normal
FPC 3 Intake	53	59	72	67	80	75	85
FPC 3 Exhaust A	77	85	98	93	103	98	108
FPC 3 Exhaust B	54	62	80	75	103	98	108
FPC 3 EA0 Chip	64	72	90	90	100	100	105
FPC 3 EA0_XR0 Chip	79	87	102	102	106	106	108
FPC 3 EA0_XR1 Chip	79	87	102	102	106	106	108
FPC 3 EA1 Chip	64	72	90	90	100	100	105
FPC 3 EA1_XR0 Chip	79	87	102	102	106	106	108
FPC 3 EA1_XR1 Chip	79	87	102	102	106	106	108
FPC 3 PEX Chip	74	82	100	100	105	105	110
FPC 3 EA2 Chip	64	72	90	90	100	100	105
FPC 3 EA2_XR0 Chip	79	87	102	102	106	106	108
FPC 3 EA2_XR1 Chip	79	87	102	102	106	106	108
FPC 3 EA3 Chip	64	72	90	90	100	100	105
FPC 3 EA3_XR0 Chip	79	87	102	102	106	106	108
FPC 3 EA3_XR1 Chip	79	87	102	102	106	106	108
FPC 3 EA0_HMC0 Logic die	81	89	103	103	107	107	111
FPC 3 EA0_HMC0 DRAM botm	76	84	98	98	102	102	106
FPC 3 EA0_HMC1 Logic die	81	89	103	103	107	107	111
FPC 3 EA0_HMC1 DRAM botm	76	84	98	98	102	102	106
FPC 3 EA0_HMC2 Logic die	81	89	103	103	107	107	111
FPC 3 EA0_HMC2 DRAM botm	76	84	98	98	102	102	106
FPC 3 EA1_HMC0 Logic die	81	89	103	103	107	107	111
FPC 3 EA1_HMC0 DRAM botm	76	84	98	98	102	102	106
FPC 3 EA1_HMC1 Logic die	81	89	103	103	107	107	111
FPC 3 EA1_HMC1 DRAM botm	76	84	98	98	102	102	106
FPC 3 EA1_HMC2 Logic die	81	89	103	103	107	107	111

FPC 3 EA1_HMC2 DRAM botm	76	84	98	98	102	102	106
FPC 3 EA2_HMC0 Logic die	81	89	103	103	107	107	111
FPC 3 EA2_HMC0 DRAM botm	76	84	98	98	102	102	106
FPC 3 EA2_HMC1 Logic die	81	89	103	103	107	107	111
FPC 3 EA2_HMC1 DRAM botm	76	84	98	98	102	102	106
FPC 3 EA2_HMC2 Logic die	81	89	103	103	107	107	111
FPC 3 EA2_HMC2 DRAM botm	76	84	98	98	102	102	106
FPC 3 EA3_HMC0 Logic die	81	89	103	103	107	107	111
FPC 3 EA3_HMC0 DRAM botm	76	84	98	98	102	102	106
FPC 3 EA3_HMC1 Logic die	81	89	103	103	107	107	111
FPC 3 EA3_HMC1 DRAM botm	76	84	98	98	102	102	106
FPC 3 EA3_HMC2 Logic die	81	89	103	103	107	107	111
FPC 3 EA3_HMC2 DRAM botm	76	84	98	98	102	102	106
FPC 4 Intake	46	55	65	60	81	76	90
FPC 4 Exhaust A	61	70	80	75	100	95	110
FPC 4 Exhaust B	61	70	80	75	95	90	105
FPC 4 EA0 Chip	86	95	105	100	117	112	123
FPC 4 EA0_XR0 Chip	86	95	105	100	110	105	116
FPC 4 EA0_XR1 Chip	86	95	105	100	115	110	121
FPC 4 EA1 Chip	86	95	105	100	117	112	123
FPC 4 EA1_XR0 Chip	86	95	105	100	110	105	116
FPC 4 EA1_XR1 Chip	86	95	105	100	115	110	121
FPC 4 PCIE_SW Chip	81	90	105	100	115	110	121
FPC 4 EA0_HMC0 DRAM botm	86	95	105	100	115	110	121
FPC 4 EA0_HMC1 DRAM botm	86	95	105	100	115	110	121
FPC 4 EA1_HMC0 DRAM botm	86	95	105	100	115	110	121
FPC 4 EA1_HMC1 DRAM botm	86	95	105	100	115	110	121
FPC 7 Intake	53	59	72	67	80	75	85
FPC 7 Exhaust A	77	85	98	93	103	98	108
FPC 7 Exhaust B	54	62	80	75	103	98	108
FPC 7 EA0 Chip	64	72	90	90	100	100	105
FPC 7 EA0_XR0 Chip	79	87	102	102	106	106	108
FPC 7 EA0_XR1 Chip	79	87	102	102	106	106	108
FPC 7 EA1 Chip	64	72	90	90	100	100	105
FPC 7 EA1_XR0 Chip	79	87	102	102	106	106	108
FPC 7 EA1_XR1 Chip	79	87	102	102	106	106	108
FPC 7 PEX Chip	74	82	100	100	105	105	110
FPC 7 EA2 Chip	64	72	90	90	100	100	105
FPC 7 EA2_XR0 Chip	79	87	102	102	106	106	108
FPC 7 EA2_XR1 Chip	79	87	102	102	106	106	108
FPC 7 EA3 Chip	64	72	90	90	100	100	105
FPC 7 EA3_XR0 Chip	79	87	102	102	106	106	108
FPC 7 EA3_XR1 Chip	79	87	102	102	106	106	108

FPC 7 EA0_HMC0 Logic die	81	89	103	103	107	107	111
FPC 7 EA0_HMC0 DRAM botm	76	84	98	98	102	102	106
FPC 7 EA0_HMC1 Logic die	81	89	103	103	107	107	111
FPC 7 EA0_HMC1 DRAM botm	76	84	98	98	102	102	106
FPC 7 EA0_HMC2 Logic die	81	89	103	103	107	107	111
FPC 7 EA0_HMC2 DRAM botm	76	84	98	98	102	102	106
FPC 7 EA1_HMC0 Logic die	81	89	103	103	107	107	111
FPC 7 EA1_HMC0 DRAM botm	76	84	98	98	102	102	106
FPC 7 EA1_HMC1 Logic die	81	89	103	103	107	107	111
FPC 7 EA1_HMC1 DRAM botm	76	84	98	98	102	102	106
FPC 7 EA1_HMC2 Logic die	81	89	103	103	107	107	111
FPC 7 EA1_HMC2 DRAM botm	76	84	98	98	102	102	106
FPC 7 EA2_HMC0 Logic die	81	89	103	103	107	107	111
FPC 7 EA2_HMC0 DRAM botm	76	84	98	98	102	102	106
FPC 7 EA2_HMC1 Logic die	81	89	103	103	107	107	111
FPC 7 EA2_HMC1 DRAM botm	76	84	98	98	102	102	106
FPC 7 EA2_HMC2 Logic die	81	89	103	103	107	107	111
FPC 7 EA2_HMC2 DRAM botm	76	84	98	98	102	102	106
FPC 7 EA3_HMC0 Logic die	81	89	103	103	107	107	111
FPC 7 EA3_HMC0 DRAM botm	76	84	98	98	102	102	106
FPC 7 EA3_HMC1 Logic die	81	89	103	103	107	107	111
FPC 7 EA3_HMC1 DRAM botm	76	84	98	98	102	102	106
FPC 7 EA3_HMC2 Logic die	81	89	103	103	107	107	111
FPC 7 EA3_HMC2 DRAM botm	76	84	98	98	102	102	106

As per the above output, the MPC7E, MPC8E, and MPC9E are installed in the FPC slots 4, 7, and 3, respectively.

show chassis temperature-thresholds (MX2020 Router with MPC4E)

```
user@host> show chassis temperature-thresholds
```

Item	Fan speed		Yellow alarm		Red alarm		Fire Shutdown
	(degrees C)		(degrees C)		(degrees C)		(degrees C)
	Normal	High	Normal	Bad fan	Normal	Bad fan	Normal
Routing Engine 0	70	80	95	95	110	110	112
Routing Engine 1	70	80	95	95	110	110	112
CB 0 IntakeA-Zone0	60	65	78	75	85	80	95
CB 0 IntakeB-Zone1	60	65	78	75	85	80	95
CB 0 IntakeC-Zone0	60	65	78	75	85	80	95
CB 0 ExhaustA-Zone0	60	65	78	75	85	80	95
CB 0 ExhaustB-Zone1	60	65	78	75	85	80	95
CB 0 TCBC-Zone0	60	65	78	75	85	80	95

CB 1 IntakeA-Zone0	60	65	78	75	85	80	95
CB 1 IntakeB-Zone1	60	65	78	75	85	80	95
CB 1 IntakeC-Zone0	60	65	78	75	85	80	95
CB 1 ExhaustA-Zone0	60	65	78	75	85	80	95
CB 1 ExhaustB-Zone1	60	65	78	75	85	80	95
CB 1 TCBC-Zone0	60	65	78	75	85	80	95
SPMB 0 Intake	56	62	75	63	83	76	95
SPMB 1 Intake	56	62	75	63	83	76	95
SFB 0 Intake-Zone0	56	62	70	70	85	85	89
SFB 0 Exhaust-Zone1	56	62	70	70	85	85	89
SFB 0 IntakeA-Zone0	56	62	70	70	85	85	89
SFB 0 IntakeB-Zone1	56	62	70	70	85	85	89
SFB 0 Exhaust-Zone0	56	62	70	70	85	85	89
SFB 0 SFB-XF2-Zone1	70	75	90	85	95	90	100
SFB 0 SFB-XF1-Zone0	70	75	90	85	95	90	100
SFB 0 SFB-XF0-Zone0	70	75	90	85	95	90	100
SFB 1 Intake-Zone0	56	62	70	70	85	85	89
SFB 1 Exhaust-Zone1	56	62	70	70	85	85	89
SFB 1 IntakeA-Zone0	56	62	70	70	85	85	89
SFB 1 IntakeB-Zone1	56	62	70	70	85	85	89
SFB 1 Exhaust-Zone0	56	62	70	70	85	85	89
SFB 1 SFB-XF2-Zone1	70	75	90	85	95	90	100
SFB 1 SFB-XF1-Zone0	70	75	90	85	95	90	100
SFB 1 SFB-XF0-Zone0	70	75	90	85	95	90	100
SFB 2 Intake-Zone0	56	62	70	70	85	85	89
SFB 2 Exhaust-Zone1	56	62	70	70	85	85	89
SFB 2 IntakeA-Zone0	56	62	70	70	85	85	89
SFB 2 IntakeB-Zone1	56	62	70	70	85	85	89
SFB 2 Exhaust-Zone0	56	62	70	70	85	85	89
SFB 2 SFB-XF2-Zone1	70	75	90	85	95	90	100
SFB 2 SFB-XF1-Zone0	70	75	90	85	95	90	100
SFB 2 SFB-XF0-Zone0	70	75	90	85	95	90	100
SFB 3 Intake-Zone0	56	62	70	70	85	85	89
SFB 3 Exhaust-Zone1	56	62	70	70	85	85	89
SFB 3 IntakeA-Zone0	56	62	70	70	85	85	89
SFB 3 IntakeB-Zone1	56	62	70	70	85	85	89
SFB 3 Exhaust-Zone0	56	62	70	70	85	85	89
SFB 3 SFB-XF2-Zone1	70	75	90	85	95	90	100
SFB 3 SFB-XF1-Zone0	70	75	90	85	95	90	100
SFB 3 SFB-XF0-Zone0	70	75	90	85	95	90	100
SFB 4 Intake-Zone0	56	62	70	70	85	85	89
SFB 4 Exhaust-Zone1	56	62	70	70	85	85	89
SFB 4 IntakeA-Zone0	56	62	70	70	85	85	89

SFB 4 IntakeB-Zone1	56	62	70	70	85	85	89
SFB 4 Exhaust-Zone0	56	62	70	70	85	85	89
SFB 4 SFB-XF2-Zone1	70	75	90	85	95	90	100
SFB 4 SFB-XF1-Zone0	70	75	90	85	95	90	100
SFB 4 SFB-XF0-Zone0	70	75	90	85	95	90	100
SFB 5 Intake-Zone0	56	62	70	70	85	85	89
SFB 5 Exhaust-Zone1	56	62	70	70	85	85	89
SFB 5 IntakeA-Zone0	56	62	70	70	85	85	89
SFB 5 IntakeB-Zone1	56	62	70	70	85	85	89
SFB 5 Exhaust-Zone0	56	62	70	70	85	85	89
SFB 5 SFB-XF2-Zone1	70	75	90	85	95	90	100
SFB 5 SFB-XF1-Zone0	70	75	90	85	95	90	100
SFB 5 SFB-XF0-Zone0	70	75	90	85	95	90	100
SFB 6 Intake-Zone0	56	62	70	70	85	85	89
SFB 6 Exhaust-Zone1	56	62	70	70	85	85	89
SFB 6 IntakeA-Zone0	56	62	70	70	85	85	89
SFB 6 IntakeB-Zone1	56	62	70	70	85	85	89
SFB 6 Exhaust-Zone0	56	62	70	70	85	85	89
SFB 6 SFB-XF2-Zone1	70	75	90	85	95	90	100
SFB 6 SFB-XF1-Zone0	70	75	90	85	95	90	100
SFB 6 SFB-XF0-Zone0	70	75	90	85	95	90	100
SFB 7 Intake-Zone0	56	62	70	70	85	85	89
SFB 7 Exhaust-Zone1	56	62	70	70	85	85	89
SFB 7 IntakeA-Zone0	56	62	70	70	85	85	89
SFB 7 IntakeB-Zone1	56	62	70	70	85	85	89
SFB 7 Exhaust-Zone0	56	62	70	70	85	85	89
SFB 7 SFB-XF2-Zone1	70	75	90	85	95	90	100
SFB 7 SFB-XF1-Zone0	70	75	90	85	95	90	100
SFB 7 SFB-XF0-Zone0	70	75	90	85	95	90	100
FPC 0	55	60	75	65	90	80	95
FPC 9	55	60	75	65	90	80	95
FPC 10	55	60	75	65	90	80	95
FPC 14	55	60	75	65	95	80	100
FPC 19	55	60	75	65	90	80	95
ADC 0 Intake	50	55	60	60	65	65	80
ADC 0 Exhaust	50	55	60	60	65	65	80
ADC 0 ADC-XF1	70	75	90	85	95	90	100
ADC 0 ADC-XF0	70	75	90	85	95	90	100
ADC 9 Intake	50	55	60	60	65	65	80
ADC 9 Exhaust	50	55	60	60	65	65	80
ADC 9 ADC-XF1	70	75	90	85	95	90	100
ADC 9 ADC-XF0	70	75	90	85	95	90	100
ADC 10 Intake	50	55	60	60	65	65	80

ADC 10 Exhaust	50	55	60	60	65	65	80
ADC 10 ADC-XF1	70	75	90	85	95	90	100
ADC 10 ADC-XF0	70	75	90	85	95	90	100
ADC 14 Intake	50	55	60	60	65	65	80
ADC 14 Exhaust	50	55	60	60	65	65	80
ADC 14 ADC-XF1	70	75	90	85	95	90	100
ADC 14 ADC-XF0	70	75	90	85	95	90	100
ADC 19 Intake	50	55	60	60	65	65	80
ADC 19 Exhaust	50	55	60	60	65	65	80
ADC 19 ADC-XF1	70	75	90	85	95	90	100
ADC 19 ADC-XF0	70	75	90	85	95	90	100

show chassis temperature-thresholds (MX2008 Routers)

```
user@host> show chassis temperature-thresholds
```

Item	Fan speed (degrees C)		Yellow alarm (degrees C)		Red alarm (degrees C)		Fire Shutdown (degrees C)
	Normal	High	Normal	Bad fan	Normal	Bad fan	Normal
Routing Engine 0 CPU	58	63	78	75	93	90	98
Routing Engine 1 CPU	58	63	78	75	93	90	98
CB 0 Inlet1	55	60	65	62	75	72	85
CB 0 Inlet2	45	50	61	58	80	77	90
CB 0 Inlet3	57	62	68	65	80	77	90
CB 0 Inlet4	55	60	80	77	90	87	95
CB 0 Exhaust1	55	60	65	62	75	72	85
CB 0 Exhaust2	50	55	60	57	80	77	90
CB 0 Exhaust3	70	75	81	78	91	88	96
CB 0 Exhaust4	75	80	90	87	100	97	105
CB 1 Inlet1	55	60	65	62	75	72	85
CB 1 Inlet2	45	50	61	58	80	77	90
CB 1 Inlet3	57	62	68	65	80	77	90
CB 1 Inlet4	55	60	80	77	90	87	95
CB 1 Exhaust1	55	60	65	62	75	72	85
CB 1 Exhaust2	50	55	60	57	80	77	90
CB 1 Exhaust3	70	75	81	78	91	88	96
CB 1 Exhaust4	75	80	90	87	100	97	105
SFB 0 Inlet1	49	54	62	59	76	73	81
SFB 0 Inlet2	65	70	71	68	83	80	88
SFB 0 Exhaust1	45	50	61	58	75	72	80
SFB 0 Exhaust2	60	65	69	66	80	77	85
SFB 0 SFB2-PF-local	65	70	75	72	95	92	100

SFB 0 SFB2-PF-die	88	93	98	95	118	115	120
SFB 1 Inlet1	49	54	62	59	76	73	81
SFB 1 Inlet2	65	70	71	68	83	80	88
SFB 1 Exhaust1	45	50	61	58	75	72	80
SFB 1 Exhaust2	60	65	69	66	80	77	85
SFB 1 SFB2-PF-local	65	70	75	72	95	92	100
SFB 1 SFB2-PF-die	88	93	98	95	118	115	120
SFB 2 Inlet1	49	54	62	59	76	73	81
SFB 2 Inlet2	65	70	71	68	83	80	88
SFB 2 Exhaust1	45	50	61	58	75	72	80
SFB 2 Exhaust2	60	65	69	66	80	77	85
SFB 2 SFB2-PF-local	65	70	75	72	95	92	100
SFB 2 SFB2-PF-die	88	93	98	95	118	115	120
SFB 3 Inlet1	49	54	62	59	76	73	81
SFB 3 Inlet2	65	70	71	68	83	80	88
SFB 3 Exhaust1	45	50	61	58	75	72	80
SFB 3 Exhaust2	60	65	69	66	80	77	85
SFB 3 SFB2-PF-local	65	70	75	72	95	92	100
SFB 3 SFB2-PF-die	88	93	98	95	118	115	120
SFB 4 Inlet1	49	54	62	59	76	73	81
SFB 4 Inlet2	65	70	71	68	83	80	88
SFB 4 Exhaust1	45	50	61	58	75	72	80
SFB 4 Exhaust2	60	65	69	66	80	77	85
SFB 4 SFB2-PF-local	65	70	75	72	95	92	100
SFB 4 SFB2-PF-die	88	93	98	95	118	115	120
SFB 5 Inlet1	49	54	62	59	76	73	81
SFB 5 Inlet2	65	70	71	68	83	80	88
SFB 5 Exhaust1	45	50	61	58	75	72	80
SFB 5 Exhaust2	60	65	69	66	80	77	85
SFB 5 SFB2-PF-local	65	70	75	72	95	92	100
SFB 5 SFB2-PF-die	88	93	98	95	118	115	120
SFB 6 Inlet1	49	54	62	59	76	73	81
SFB 6 Inlet2	65	70	71	68	83	80	88
SFB 6 Exhaust1	45	50	61	58	75	72	80
SFB 6 Exhaust2	60	65	69	66	80	77	85
SFB 6 SFB2-PF-local	65	70	75	72	95	92	100
SFB 6 SFB2-PF-die	88	93	98	95	118	115	120
SFB 7 Inlet1	49	54	62	59	76	73	81
SFB 7 Inlet2	65	70	71	68	83	80	88
SFB 7 Exhaust1	45	50	61	58	75	72	80
SFB 7 Exhaust2	60	65	69	66	80	77	85
SFB 7 SFB2-PF-local	65	70	75	72	95	92	100
SFB 7 SFB2-PF-die	88	93	98	95	118	115	120

FPC 0	55	60	75	65	90	80	95
FPC 3	55	60	75	65	105	80	110
FPC 5	55	60	75	65	105	80	110
FPC 7	55	60	75	65	90	80	95
FPC 9 Intake	60	65	75	75	85	85	95
FPC 9 Exhaust A	60	65	75	75	85	85	95
FPC 9 Exhaust B	60	65	75	75	85	85	95
FPC 9 XL 0 Chip	70	75	85	85	102	102	110
FPC 9 XL 0 XR2 0 Chip	75	80	90	90	105	105	115
FPC 9 XL 0 XR2 1 Chip	75	80	90	90	105	105	115
FPC 9 XL 1 Chip	70	75	85	85	102	102	110
FPC 9 XL 1 XR2 0 Chip	75	80	90	90	105	105	115
FPC 9 XL 1 XR2 1 Chip	75	80	90	90	105	105	115
FPC 9 XM 0 Chip	70	75	85	85	100	100	110
FPC 9 XM 1 Chip	70	75	85	85	100	100	110
FPC 9 XM 2 Chip	70	75	85	85	100	100	110
FPC 9 XM 3 Chip	70	75	85	85	100	100	110
FPC 9 PCIe Switch Chip	80	85	95	95	105	105	120
ADC 0 Intake	50	55	65	65	75	75	80
ADC 0 Exhaust	50	55	65	65	75	75	80
ADC 0 ADC-XF1	70	75	90	85	95	90	100
ADC 0 ADC-XF0	70	75	90	85	95	90	100
ADC 3 Intake	50	55	65	65	75	75	80
ADC 3 Exhaust	50	55	65	65	75	75	80
ADC 3 ADC-XF1	70	75	90	85	95	90	100
ADC 3 ADC-XF0	70	75	90	85	95	90	100
ADC 5 Intake	50	55	65	65	75	75	80
ADC 5 Exhaust	50	55	65	65	75	75	80
ADC 5 ADC-XF1	70	75	90	85	95	90	100
ADC 5 ADC-XF0	70	75	90	85	95	90	100
ADC 7 Intake	50	55	65	65	75	75	80
ADC 7 Exhaust	50	55	65	65	75	75	80
ADC 7 ADC-XF1	70	75	90	85	95	90	100
ADC 7 ADC-XF0	70	75	90	85	95	90	100

show chassis temperature-thresholds (MX204 Router)

```
user@host> show chassis temperature-thresholds
```

	Fan speed	Yellow alarm	Red alarm	Fire
Shutdown				

(degrees C)	(degrees C)		(degrees C)		(degrees C)		Normal
	Normal	High	Normal	Bad fan	Normal	Bad fan	
Item	Normal	High	Normal	Bad fan	Normal	Bad fan	Normal
Routing Engine	48	54	85	85	100	100	102
CB Top Right Inlet Sensor	35	40	63	63	85	85	95
CB Top Left Inlet Sensor	40	45	65	65	85	85	95
CB Top Right Exhaust Sensor	45	50	68	68	85	85	95
CB Top Left Exhaust Sensor	65	70	78	78	85	85	95
CB CPU Core-0 Temp	65	70	80	80	90	90	100
CB CPU Core-1 Temp	65	70	80	80	90	90	100
CB CPU Core-2 Temp	65	70	80	80	90	90	100
CB CPU Core-3 Temp	65	70	80	80	90	90	100
CB CPU Core-4 Temp	65	70	80	80	90	90	100
CB CPU Core-5 Temp	65	70	80	80	90	90	100
CB CPU Core-6 Temp	65	70	80	80	90	90	100
CB CPU Core-7 Temp	65	70	80	80	90	90	100
FPC EA0_HMC0 Logic die	85	90	95	95	105	105	110
FPC EA0_HMC0 DRAM botm	80	85	90	90	105	105	110
FPC EA0_HMC1 Logic die	85	90	95	95	105	105	110
FPC EA0_HMC1 DRAM botm	80	85	90	90	105	105	110
FPC EA0 Chip	92	97	103	103	109	109	115
FPC EA0-XR0 Chip	85	90	98	98	103	103	110
FPC EA0-XR1 Chip	85	90	98	98	103	103	110

show chassis temperature-thresholds (MX10004 and MX10008 Router)

```
user@host> show chassis temperature-thresholds
```

Shutdown	Fan speed		Yellow alarm		Red alarm		Fire
	(degrees C)		(degrees C)		(degrees C)		
Item	Normal	High	Normal	Bad fan	Normal	Bad fan	Normal
SFB 0 Intake-Top Temp	58	63	100	100	105	105	115
SFB 0 Intake-Middle-High Temp	63	68	100	100	105	105	115
SFB 0 Intake-Middle-Low Temp	66	71	100	100	105	105	115
SFB 0 Intake-Bottom Temp	65	70	100	100	105	105	115
SFB 0 Exhaust-Top Temp	82	87	100	100	105	105	115
SFB 0 Exhaust-Middle Temp	76	81	100	100	105	105	115
SFB 0 Exhaust-Bottom Temp	77	82	100	100	105	105	115
SFB 0 PCIe Switch Temp	70	75	110	110	115	115	125
SFB 0 ZF0 External Temp	85	90	95	95	116	116	121
SFB 0 ZF1 External Temp	84	89	95	95	116	116	121

SFB 0 ZF0 Internal Main	85	90	95	95	116	116	121
SFB 0 ZF0 Internal Remote 0	87	92	95	95	116	116	121
SFB 0 ZF0 Internal Remote 1	89	94	95	95	116	116	121
SFB 0 ZF0 Internal Remote 2	86	91	95	95	116	116	121
SFB 0 ZF0 Internal Remote 3	88	93	95	95	116	116	121
SFB 0 ZF0 Internal Remote 4	88	93	95	95	116	116	121
SFB 0 ZF0 Internal Remote 5	87	92	95	95	116	116	121
SFB 0 ZF0 Internal Remote 6	86	91	95	95	116	116	121
SFB 0 ZF1 Internal Main	84	89	95	95	116	116	121
SFB 0 ZF1 Internal Remote 0	85	90	95	95	116	116	121
SFB 0 ZF1 Internal Remote 1	88	93	95	95	116	116	121
SFB 0 ZF1 Internal Remote 2	86	91	95	95	116	116	121
SFB 0 ZF1 Internal Remote 3	88	93	95	95	116	116	121
SFB 0 ZF1 Internal Remote 4	87	92	95	95	116	116	121
SFB 0 ZF1 Internal Remote 5	85	90	95	95	116	116	121
SFB 0 ZF1 Internal Remote 6	87	92	95	95	116	116	121

show chassis temperature-thresholds (PTX10008 Routers)

```
user@host> show chassis temperature-thresholds
```

Item	Fan speed (degrees C)		Yellow alarm (degrees C)		Red alarm (degrees C)		Fire Shutdown (degrees C)
	Normal	High	Normal	Bad fan	Normal	Bad fan	Normal
Routing Engine 0	48	54	85	85	100	100	102
Routing Engine 1	48	54	85	85	100	100	102
CB 0 Intake Temp Sensor	30	35	80	80	85	85	95
CB 0 Exhaust Temp Sensor	30	35	80	80	85	85	95
CB 0 CPU Die Temp Sensor	40	45	95	95	100	100	110
CB 1 Intake Temp Sensor	30	35	80	80	85	85	95
CB 1 Exhaust Temp Sensor	30	35	80	80	85	85	95
CB 1 CPU Die Temp Sensor	40	45	95	95	100	100	110
FPC 0 Intake-A Temp Sensor	30	35	80	80	85	85	95
FPC 0 Intake-B Temp Sensor	30	35	80	80	85	85	95
FPC 0 Exhaust-A Temp Sensor	30	35	80	80	85	85	95
FPC 0 Exhaust-B Temp Sensor	30	35	80	80	85	85	95
FPC 0 Exhaust-C Temp Sensor	30	35	80	80	85	85	95
FPC 0 PE0 Temp Sensor	40	45	100	100	105	105	115
FPC 0 PE1 Temp Sensor	40	45	100	100	105	105	115
FPC 0 PE2 Temp Sensor	40	45	100	100	105	105	115
FPC 0 LCPU Temp Sensor	40	45	95	95	100	100	110
FPC 5 Intake-A Temp Sensor	30	35	80	80	85	85	95

FPC 5 Intake-B Temp Sensor	30	35	80	80	85	85	95
FPC 5 Exhaust-A Temp Sensor	30	35	80	80	85	85	95
FPC 5 Exhaust-B Temp Sensor	30	35	80	80	85	85	95
FPC 5 Exhaust-C Temp Sensor	30	35	80	80	85	85	95
FPC 5 PE0 Temp Sensor	40	45	100	100	105	105	115
FPC 5 PE1 Temp Sensor	40	45	100	100	105	105	115
FPC 5 PE2 Temp Sensor	40	45	100	100	105	105	115
FPC 5 PE3 Temp Sensor	40	45	100	100	105	105	115
FPC 5 PE4 Temp Sensor	40	45	100	100	105	105	115
FPC 5 PE5 Temp Sensor	40	45	100	100	105	105	115
FPC 5 LCPU Temp Sensor	40	45	95	95	100	100	110
FPC 6 Intake-A Temp Sensor	30	35	80	80	85	85	95
FPC 6 Intake-B Temp Sensor	30	35	80	80	85	85	95
FPC 6 Exhaust-A Temp Sensor	30	35	80	80	85	85	95
FPC 6 Exhaust-B Temp Sensor	30	35	80	80	85	85	95
FPC 6 Exhaust-C Temp Sensor	30	35	80	80	85	85	95
FPC 6 PE0 Temp Sensor	40	45	100	100	105	105	115
FPC 6 PE1 Temp Sensor	40	45	100	100	105	105	115
FPC 6 PE2 Temp Sensor	40	45	100	100	105	105	115
FPC 6 PE3 Temp Sensor	40	45	100	100	105	105	115
FPC 6 PE4 Temp Sensor	40	45	100	100	105	105	115
FPC 6 PE5 Temp Sensor	40	45	100	100	105	105	115
FPC 6 LCPU Temp Sensor	40	45	95	95	100	100	110
SIB 0 Intake-A Temp Sensor	40	45	90	90	95	95	105
SIB 0 Intake-B Temp Sensor	40	45	90	90	95	95	105
SIB 0 Exhaust-A Temp Sensor	40	45	90	90	95	95	105
SIB 0 Exhaust-B Temp Sensor	40	45	90	90	95	95	105
SIB 0 PF0 Temp Sensor	50	55	100	100	105	105	115
SIB 0 PF1 Temp Sensor	50	55	100	100	105	105	115
SIB 1 Intake-A Temp Sensor	40	45	90	90	95	95	105
SIB 1 Intake-B Temp Sensor	40	45	90	90	95	95	105
SIB 1 Exhaust-A Temp Sensor	40	45	90	90	95	95	105
SIB 1 Exhaust-B Temp Sensor	40	45	90	90	95	95	105
SIB 1 PF0 Temp Sensor	50	55	100	100	105	105	115
SIB 1 PF1 Temp Sensor	50	55	100	100	105	105	115

show chassis temperature-thresholds (T4000 Core Routers)

```
user@host> show chassis temperature-thresholds
```

```
Fan speed      Yellow alarm    Red alarm      Fire Shutdown
```

Item	(degrees C)		(degrees C)		(degrees C)		(degrees C)
	Normal	High	Normal	Bad fan	Normal	Bad fan	Normal
Chassis default	48	54	65	55	75	65	100
Routing Engine 0	55	65	85	85	100	100	102
Routing Engine 1	55	65	85	85	100	100	102
FPC 0	63	68	75	70	90	83	95
FPC 3	63	68	75	70	90	83	95
FPC 5	56	62	75	63	83	76	95
FPC 6	63	68	75	70	90	83	95
SIB 0	64	70	76	72	87	84	95
SIB 1	64	70	76	72	87	84	95
SIB 2	64	70	76	72	87	84	95
SIB 3	64	70	76	72	87	84	95
SIB 4	64	70	76	72	87	84	95

show chassis temperature-thresholds (TX Matrix Plus Router)

```
user@host> show chassis temperature-thresholds
sfc0-re0:
```

```
-----
```

Item	Fan speed (degrees C)		Yellow alarm (degrees C)		Red alarm (degrees C)	
	Normal	High	Normal	Bad fan	Normal	Bad fan
Chassis default	48	54	65	55	75	65
Routing Engine 0	55	65	85	85	100	100
Routing Engine 1	55	65	85	85	100	100
SIB F13 0	64	70	76	72	90	84
SIB F13 3	64	70	76	72	90	84
SIB F13 6	64	70	76	72	90	84
SIB F13 8	64	70	76	72	90	84
SIB F13 11	64	70	76	72	90	84
SIB F13 12	64	70	76	72	90	84
SIB F2S 16	64	70	76	72	90	84
SIB F2S 17	64	70	76	72	90	84
SIB F2S 18	64	70	76	72	90	84
SIB F2S 19	64	70	76	72	90	84
SIB F2S 20	64	70	76	72	90	84
SIB F2S 21	64	70	76	72	90	84
SIB F2S 22	64	70	76	72	90	84
SIB F2S 23	64	70	76	72	90	84
SIB F2S 24	64	70	76	72	90	84

SIB F2S 25	64	70	76	72	90	84
SIB F2S 26	64	70	76	72	90	84
SIB F2S 27	64	70	76	72	90	84
SIB F2S 28	64	70	76	72	90	84
SIB F2S 29	64	70	76	72	90	84
SIB F2S 30	64	70	76	72	90	84
SIB F2S 31	64	70	76	72	90	84
SIB F2S 32	64	70	76	72	90	84
SIB F2S 33	64	70	76	72	90	84
SIB F2S 34	64	70	76	72	90	84
SIB F2S 35	64	70	76	72	90	84

lcc0-re0:

Item	Fan speed (degrees C)		Yellow alarm (degrees C)		Red alarm (degrees C)	
	Normal	High	Normal	Bad fan	Normal	Bad fan
Chassis default	48	54	65	55	75	65
Routing Engine 0	55	65	85	85	100	100
Routing Engine 1	55	65	85	85	100	100
FPC 1	56	62	75	63	83	76
FPC 3	56	62	75	63	83	76
FPC 4	56	62	75	63	83	76
FPC 6	56	62	75	63	83	76
FPC 7	56	62	75	63	83	76
SIB 0	48	54	65	60	80	75
SIB 1	48	54	65	60	80	75
SIB 2	48	54	65	60	80	75
SIB 3	48	54	65	60	80	75
SIB 4	48	54	65	60	80	75

lcc1-re0:

Item	Fan speed (degrees C)		Yellow alarm (degrees C)		Red alarm (degrees C)	
	Normal	High	Normal	Bad fan	Normal	Bad fan
Chassis default	48	54	65	55	75	65
Routing Engine 0	55	65	85	85	100	100
Routing Engine 1	55	65	85	85	100	100
FPC 1	56	62	75	63	83	76
FPC 3	56	62	75	63	83	76
FPC 4	56	62	75	63	83	76

```
FPC 6          56    62    75    63    83    76
...
```

show chassis temperature-thresholds lcc (TX Matrix Plus Router)

```
user@host> show chassis temperature-thresholds lcc 1
lcc1-re0:
-----

```

Item	Fan speed (degrees C)		Yellow alarm (degrees C)		Red alarm (degrees C)	
	Normal	High	Normal	Bad fan	Normal	Bad fan
Chassis default	48	54	65	55	75	65
Routing Engine 0	55	65	85	85	100	100
Routing Engine 1	55	65	85	85	100	100
FPC 1	56	62	75	63	83	76
FPC 3	56	62	75	63	83	76
FPC 4	56	62	75	63	83	76
FPC 6	56	62	75	63	83	76
SIB 0	48	54	65	60	80	75
SIB 1	48	54	65	60	80	75
SIB 2	48	54	65	60	80	75
SIB 3	48	54	65	60	80	75
SIB 4	48	54	65	60	80	75

show chassis temperature-thresholds sfc (TX Matrix Plus Router)

```
user@host> show chassis temperature-thresholds sfc 0
sfc0-re0:
-----

```

Item	Fan speed (degrees C)		Yellow alarm (degrees C)		Red alarm (degrees C)	
	Normal	High	Normal	Bad fan	Normal	Bad fan
Chassis default	48	54	65	55	75	65
Routing Engine 0	55	65	85	85	100	100
Routing Engine 1	55	65	85	85	100	100
SIB F13 0	64	70	76	72	90	84
SIB F13 3	64	70	76	72	90	84
SIB F13 6	64	70	76	72	90	84
SIB F13 8	64	70	76	72	90	84
SIB F13 11	64	70	76	72	90	84

SIB F13 12	64	70	76	72	90	84
SIB F2S 16	64	70	76	72	90	84
SIB F2S 17	64	70	76	72	90	84
SIB F2S 18	64	70	76	72	90	84
SIB F2S 19	64	70	76	72	90	84
SIB F2S 20	64	70	76	72	90	84
SIB F2S 21	64	70	76	72	90	84
SIB F2S 22	64	70	76	72	90	84
SIB F2S 23	64	70	76	72	90	84
SIB F2S 24	64	70	76	72	90	84
SIB F2S 25	64	70	76	72	90	84
SIB F2S 26	64	70	76	72	90	84
SIB F2S 27	64	70	76	72	90	84
SIB F2S 28	64	70	76	72	90	84
SIB F2S 29	64	70	76	72	90	84
SIB F2S 30	64	70	76	72	90	84
SIB F2S 31	64	70	76	72	90	84
SIB F2S 32	64	70	76	72	90	84
SIB F2S 33	64	70	76	72	90	84
SIB F2S 34	64	70	76	72	90	84
SIB F2S 35	64	70	76	72	90	84

show chassis temperature-thresholds (TX Matrix Plus routers with 3D SIBs)

```
user@host> show chassis temperature-thresholds
```

```
sfc0-re0:
```

```
-----
```

Item	Fan speed (degrees C)		Yellow alarm (degrees C)		Red alarm (degrees C)		Fire Shutdown (degrees C)
	Normal	High	Normal	Bad fan	Normal	Bad fan	Normal
Chassis default	48	54	65	55	75	65	100
Routing Engine 0	70	75	90	87	102	97	115
Routing Engine 1	70	75	90	87	102	97	115
SIB F13 0 Board	60	65	78	75	85	80	95
SIB F13 0 XF Junction	70	75	82	74	105	100	107
SIB F13 4 Board	60	65	78	75	85	80	95
SIB F13 4 XF Junction	70	75	82	74	105	100	107
SIB F13 6 Board	60	65	78	75	85	80	95
SIB F13 6 XF Junction	70	75	82	74	105	100	107
SIB F2S 16 Board	60	65	78	75	85	80	95
SIB F2S 16 XF Junction	70	75	82	74	105	100	107

SIB F2S 17 Board	60	65	78	75	85	80	95
SIB F2S 17 XF Junction	70	75	82	74	105	100	107
SIB F2S 18 Board	60	65	78	75	85	80	95
SIB F2S 18 XF Junction	70	75	82	74	105	100	107
SIB F2S 19 Board	60	65	78	75	85	80	95
SIB F2S 19 XF Junction	70	75	82	74	105	100	107
SIB F2S 24 Board	60	65	78	75	85	80	95
SIB F2S 24 XF Junction	70	75	82	74	105	100	107
SIB F2S 25 Board	60	65	78	75	85	80	95
SIB F2S 25 XF Junction	70	75	82	74	105	100	107
SIB F2S 26 Board	60	65	78	75	85	80	95
SIB F2S 26 XF Junction	70	75	82	74	105	100	107
SIB F2S 27 Board	60	65	78	75	85	80	95
SIB F2S 27 XF Junction	70	75	82	74	105	100	107

lcc0-re0:

Item	Fan speed (degrees C)		Yellow alarm (degrees C)		Red alarm (degrees C)		Fire Shutdown (degrees C)
	Normal	High	Normal	Bad fan	Normal	Bad fan	Normal
Chassis default	48	54	65	55	75	65	100
Routing Engine 0	55	65	85	85	100	100	102
FPC 0	63	68	75	70	90	83	95
FPC 1	56	62	75	63	83	76	95
FPC 7	56	62	75	63	83	76	95
SIB 0	64	70	76	72	87	84	95
SIB 0 ASIC Junction	63	68	75	70	105	100	107
SIB 2	64	70	76	72	87	84	95
SIB 2 ASIC Junction	63	68	75	70	105	100	107
SIB 3	64	70	76	72	87	84	95
SIB 3 ASIC Junction	63	68	75	70	105	100	107

show chassis temperature-thresholds (QFX3500 Switch and QFX3600)

```
user@switch> show chassis temperature-thresholds
```

Item	Fan speed (degrees C)		Yellow alarm (degrees C)		Red alarm (degrees C)	
	Normal	High	Normal	Bad fan	Normal	Bad fan
FPC Sensor TopLeft I	48	56	53	43	56	46
FPC Sensor TopRight I	46	54	51	41	54	44

FPC Sensor TopLeft E	58	65	62	52	65	55
FPC Sensor TopRight E	56	64	61	51	64	54
FPC Sensor TopMiddle I	58	64	61	51	64	54
FPC Sensor TopMiddle E	67	74	71	61	74	64
FPC Sensor Bottom I	59	67	64	54	67	57
FPC Sensor Bottom E	66	73	70	60	73	63
FPC Sensor Die Temp	69	75	72	62	75	65
FPC Sensor Mgmt Brd I	46	54	51	41	54	44
FPC Sensor Switch I	56	63	60	50	63	53

show chassis temperature-thresholds interconnect-device (QFabric System)

```

user@switch> show chassis temperature-thresholds interconnect-device
interconnect1
temperature-thresholds interconnect-device interconnect1

```

Item	Fan speed		Yellow alarm		Red alarm	
	Normal	High	Normal	Bad fan	Normal	Bad fan
Chassis default	48	54	65	55	75	65

show chassis temperature-thresholds (QFX5700)

```

user@switch> show chassis temperature-thresholds

```

Item	Fan speed		Yellow alarm		Red alarm				
	Normal	High	Normal	Bad fan	Normal	Bad fan			
Routing Engine 0 CPU Temperature			48	54	85	85	100	100	102
Routing Engine 1 CPU Temperature			48	54	85	85	100	100	102
CB 0 Intake 1 Temp Sensor			60	65	75	75	85	85	95
CB 0 Intake 2 Temp Sensor			60	65	75	75	85	85	95
CB 0 Middle Temp Sensor			83	90	98	98	105	105	110
CB 1 Intake 1 Temp Sensor			60	65	75	75	85	85	95
CB 1 Intake 2 Temp Sensor			60	65	75	75	85	85	95
CB 1 Exhaust 1 Temp Sensor			83	90	98	98	105	105	110
CB 1 Exhaust 2 Temp Sensor			83	90	98	98	105	105	110
CB 1 Middle Temp Sensor			83	90	98	98	105	105	110

show chassis temperature-thresholds (PTX5000 Packet Transport Router)

```
user@switch> show chassis temperature-thresholds
user@switch> show chassis temperature-thresholds
```

Item	Fan speed (degrees C)		Yellow alarm (degrees C)		Red alarm (degrees C)		Fire Shutdown (degrees C)
	Normal	High	Normal	Bad fan	Normal	Bad fan	Normal
Routing Engine 0	80	90	95	85	105	95	115
CB 0 Exhaust A	60	65	78	75	85	80	95
CB 0 Exhaust B	60	65	78	75	85	80	95
CB 1 Exhaust A	60	65	78	75	85	80	95
CB 1 Exhaust B	60	65	78	75	85	80	95
FPC 3 Exhaust A	80	90	95	85	105	95	115
FPC 3 Exhaust B	80	90	95	85	105	95	115
FPC 3 TL5	80	90	95	85	105	95	115
FPC 3 TQ5	80	90	95	85	105	95	115
FPC 3 TL6	80	90	95	85	105	95	115
FPC 3 TQ6	80	90	95	85	105	95	115
FPC 3 TL1	80	90	95	85	105	95	115
FPC 3 TQ1	80	90	95	85	105	95	115
FPC 3 TL2	80	90	95	85	105	95	115
FPC 3 TQ2	80	90	95	85	105	95	115
FPC 3 TL4	80	90	95	85	105	95	115
FPC 3 TQ4	80	90	95	85	105	95	115
FPC 3 TL7	80	90	95	85	105	95	115
FPC 3 TQ7	80	90	95	85	105	95	115
FPC 3 TL0	80	90	95	85	105	95	115
FPC 3 TQ0	80	90	95	85	105	95	115
FPC 3 TL3	80	90	95	85	105	95	115
FPC 3 TQ3	80	90	95	85	105	95	115
SIB 0 Exhaust	60	65	78	75	85	80	95
SIB 0 Junction	75	80	90	85	105	95	115
SIB 1 Exhaust	60	65	78	75	85	80	95
SIB 1 Junction	75	80	90	85	105	95	115
SIB 2 Exhaust	60	65	78	75	85	80	95
SIB 2 Junction	75	80	90	85	105	95	115
SIB 3 Exhaust	60	65	78	75	85	80	95
SIB 3 Junction	75	80	90	85	105	95	115
SIB 4 Exhaust	60	65	78	75	85	80	95
SIB 4 Junction	75	80	90	85	105	95	115
SIB 5 Exhaust	60	65	78	75	85	80	95

SIB 5 Junction	75	80	90	85	105	95	115
SIB 6 Exhaust	60	65	78	75	85	80	95
SIB 6 Junction	75	80	90	85	105	95	115
SIB 7 Exhaust	60	65	78	75	85	80	95
SIB 7 Junction	75	80	90	85	105	95	115
SIB 8 Exhaust	60	65	78	75	85	80	95
SIB 8 Junction	75	80	90	85	105	95	115

show chassis temperature-thresholds (PTX1000 Packet Transport Router)

```
user@host> show chassis temperature-thresholds
```

Item	Fan speed (degrees C)		Yellow alarm (degrees C)		Red alarm (degrees C)		Fire Shutdown (degrees C)
	Normal	High	Normal	Bad fan	Normal	Bad fan	Normal
FPC 0 Intake Temp Sensor	30	65	65	65	70	70	75
FPC 0 Exhaust Temp Sensor	30	65	65	65	70	70	75
FPC 0 Mezz Temp Sensor 0	30	65	65	65	70	70	75
FPC 0 Mezz Temp Sensor 1	30	65	65	65	70	70	75
FPC 0 PE2 Temp Sensor	50	90	90	90	100	100	103
FPC 0 PE1 Temp Sensor	50	90	90	90	100	100	103
FPC 0 PF0 Temp Sensor	50	90	90	90	100	100	103
FPC 0 PE0 Temp Sensor	50	90	90	90	100	100	103
FPC 0 PE5 Temp Sensor	50	90	90	90	100	100	103
FPC 0 PE4 Temp Sensor	50	90	90	90	100	100	103
FPC 0 PF1 Temp Sensor	50	90	90	90	100	100	103
FPC 0 PE3 Temp Sensor	50	90	90	90	100	100	103
FPC 0 CPU Die Temp Sensor	50	90	90	90	100	100	103
FPC 0 OCX0 Temp Sensor	50	90	90	90	100	100	103

show chassis temperature-thresholds (MX Routers with Media Services Blade [MSB])

```
user@switch> show chassis temperature-thresholds
```

Item	Fan speed		Yellow alarm		Red alarm		Fire Shutdown
	Normal	High	Normal	Bad fan	Normal	Bad fan	Normal
Chassis default	48	54	65	55	75	65	100

Routing Engine 0	70	80	95	95	110	110	112
Routing Engine 1	70	80	95	95	110	110	112
FPC 0	55	60	75	65	90	80	95
FPC 1	55	60	75	65	90	80	95
FPC 2	55	60	75	65	90	80	95
FPC 4	55	60	75	65	90	80	95
FPC 5	55	60	75	65	90	80	95

show chassis temperature-thresholds (EX9251 Switches)

```
user@switch> show chassis temperature-thresholds
```

Item	Fan speed (degrees C)		Yellow alarm (degrees C)		Red alarm (degrees C)		Fire Shutdown (degrees C)		
	Normal	High	Normal	Bad fan	Normal	Bad fan	Normal		
Routing Engine			48	54	85	85	100	100	102
CB Top Right Inlet Sensor			35	40	63	63	85	85	95
CB Top Left Inlet Sensor			40	45	65	65	85	85	95
CB Top Right Exhaust Sensor			45	50	68	68	85	85	95
CB Top Left Exhaust Sensor			65	70	78	78	85	85	95
CB CPU Core-0 Temp			65	70	80	80	90	90	100
CB CPU Core-1 Temp			65	70	80	80	90	90	100
CB CPU Core-2 Temp			65	70	80	80	90	90	100
CB CPU Core-3 Temp			65	70	80	80	90	90	100
CB CPU Core-4 Temp			65	70	80	80	90	90	100
CB CPU Core-5 Temp			65	70	80	80	90	90	100
CB CPU Core-6 Temp			65	70	80	80	90	90	100
CB CPU Core-7 Temp			65	70	80	80	90	90	100
FPC EA0_HMC0 Logic die			85	90	95	95	105	105	110
FPC EA0_HMC0 DRAM botm			80	85	90	90	105	105	110
FPC EA0_HMC1 Logic die			85	90	95	95	105	105	110
FPC EA0_HMC1 DRAM botm			80	85	90	90	105	105	110
FPC EA0 Chip			92	97	103	103	109	109	115
FPC EA0-XR0 Chip			85	90	98	98	103	103	110
FPC EA0-XR1 Chip			85	90	98	98	103	103	110

show chassis temperature-thresholds (EX9253 witches)

```
user@switch> show chassis temperature-thresholds
```

Item	Fan speed (degrees C)		Yellow alarm (degrees C)		Red alarm (degrees C)		Fire Shutdown (degrees C)		
	Normal	High	Normal	Bad fan	Normal	Bad fan	Normal		
Routing Engine 0			48	54	85	85	100	100	102
CB 0 Exhaust Temp Sensor			60	65	75	75	85	85	95
CB 0 Inlet Temp Sensor			60	65	75	75	85	85	95
CB 0 CPU DIE Temp Sensor			83	90	98	98	105	105	110
CB 1 Exhaust Temp Sensor			60	65	75	75	85	85	95
CB 1 Inlet Temp Sensor			60	65	75	75	85	85	95
CB 1 CPU DIE Temp Sensor			83	90	98	98	105	105	110
FPC 0 Intake Temp Sensor			40	45	75	70	85	80	95
FPC 0 Exhaust-A Temp Sensor			55	60	85	80	90	90	100
FPC 0 Exhaust-B Temp Sensor			55	60	85	80	90	90	100
FPC 0 EA0 Chip			87	92	97	97	105	105	110
FPC 0 EA0-XR0 Chip			88	93	98	98	120	120	125
FPC 0 EA0-XR1 Chip			88	93	98	98	120	120	125
FPC 0 EA1 Chip			87	92	97	97	105	105	110
FPC 0 EA1-XR0 Chip			88	93	98	98	120	120	125
FPC 0 EA1-XR1 Chip			88	93	98	98	120	120	125
FPC 0 EA2 Chip			87	92	97	97	105	105	110
FPC 0 EA2-XR0 Chip			88	93	98	98	120	120	125
FPC 0 EA2-XR1 Chip			88	93	98	98	120	120	125
FPC 0 PF Chip			89	94	104	104	120	120	120
FPC 0 EA0_HMC0 Logic die			88	93	103	103	120	120	125
FPC 0 EA0_HMC0 DRAM botm			83	88	98	98	120	120	125
FPC 0 EA0_HMC1 Logic die			88	93	103	103	120	120	125
FPC 0 EA0_HMC1 DRAM botm			83	88	98	98	120	120	125
FPC 0 EA0_HMC2 Logic die			88	93	103	103	120	120	125
FPC 0 EA0_HMC2 DRAM botm			83	88	98	98	120	120	125
FPC 0 EA1_HMC0 Logic die			88	93	103	103	120	120	125
FPC 0 EA1_HMC0 DRAM botm			83	88	98	98	120	120	125
FPC 0 EA1_HMC1 Logic die			88	93	103	103	120	120	125
FPC 0 EA1_HMC1 DRAM botm			83	88	98	98	120	120	125
FPC 0 EA1_HMC2 Logic die			88	93	103	103	120	120	125
FPC 0 EA1_HMC2 DRAM botm			83	88	98	98	120	120	125
FPC 0 EA2_HMC0 Logic die			88	93	103	103	120	120	125
FPC 0 EA2_HMC0 DRAM botm			83	88	98	98	120	120	125
FPC 0 EA2_HMC1 Logic die			88	93	103	103	120	120	125

FPC 0 EA2_HMC1 DRAM botm	83	88	98	98	120	120	125
FPC 0 EA2_HMC2 Logic die	88	93	103	103	120	120	125
FPC 0 EA2_HMC2 DRAM botm	83	88	98	98	120	120	125
FPC 1 Intake Temp Sensor	40	45	75	70	85	80	95
FPC 1 Exhaust-A Temp Sensor	55	60	85	80	90	90	100
FPC 1 Exhaust-B Temp Sensor	55	60	85	80	90	90	100
FPC 1 EA0 Chip	87	92	97	97	105	105	110
FPC 1 EA0-XR0 Chip	88	93	98	98	120	120	125
FPC 1 EA0-XR1 Chip	88	93	98	98	120	120	125
FPC 1 EA1 Chip	87	92	97	97	105	105	110
FPC 1 EA1-XR0 Chip	88	93	98	98	120	120	125
FPC 1 EA1-XR1 Chip	88	93	98	98	120	120	125
FPC 1 EA2 Chip	87	92	97	97	105	105	110
FPC 1 EA2-XR0 Chip	88	93	98	98	120	120	125
FPC 1 EA2-XR1 Chip	88	93	98	98	120	120	125
FPC 1 PF Chip	89	94	104	104	120	120	120
FPC 1 EA0_HMC0 Logic die	88	93	103	103	120	120	125
FPC 1 EA0_HMC0 DRAM botm	83	88	98	98	120	120	125
FPC 1 EA0_HMC1 Logic die	88	93	103	103	120	120	125
FPC 1 EA0_HMC1 DRAM botm	83	88	98	98	120	120	125
FPC 1 EA0_HMC2 Logic die	88	93	103	103	120	120	125
FPC 1 EA0_HMC2 DRAM botm	83	88	98	98	120	120	125
FPC 1 EA1_HMC0 Logic die	88	93	103	103	120	120	125
FPC 1 EA1_HMC0 DRAM botm	83	88	98	98	120	120	125
FPC 1 EA1_HMC1 Logic die	88	93	103	103	120	120	125
FPC 1 EA1_HMC1 DRAM botm	83	88	98	98	120	120	125
FPC 1 EA1_HMC2 Logic die	88	93	103	103	120	120	125
FPC 1 EA1_HMC2 DRAM botm	83	88	98	98	120	120	125
FPC 1 EA2_HMC0 Logic die	88	93	103	103	120	120	125
FPC 1 EA2_HMC0 DRAM botm	83	88	98	98	120	120	125
FPC 1 EA2_HMC1 Logic die	88	93	103	103	120	120	125
FPC 1 EA2_HMC1 DRAM botm	83	88	98	98	120	120	125
FPC 1 EA2_HMC2 Logic die	88	93	103	103	120	120	125
FPC 1 EA2_HMC2 DRAM botm	83	88	98	98	120	120	125

Release Information

Command introduced in Junos OS Release 8.0.

sfc command introduced in Junos OS Release 9.6 for the TX Matrix Plus router.

satellite option introduced in Junos OS Release 14.2R3.

Command introduced in Junos OS Release 18.2R1 for MX10008 Routers and EX9253 Switches.

show interfaces extensive satellite-device

IN THIS SECTION

- [Syntax | 705](#)
- [Description | 705](#)
- [Options | 705](#)
- [Required Privilege Level | 705](#)
- [Output Fields | 706](#)
- [Sample Output | 715](#)
- [Release Information | 730](#)

Syntax

```
show interfaces extensive satellite-device (device-alias | all)
```

Description

Display the satellite device extended ports in a Junos Fusion.

Options

- | | |
|--|--|
| device-alias
<i>device-alias</i> | Display extended port information for the satellite device using the specified device alias only. |
| all | Display information for all extended ports and aggregated Ethernet interfaces with extended ports as members configured on all of the satellite devices. |

Required Privilege Level

view

Output Fields

Table 38 on page 706 lists the output fields for the `show interfaces extensive satellite-device` command. Output fields are listed in the approximate order in which they appear.

Table 38: show interfaces extensive satellite-device Output Fields

Field Name	Field Description	Level of Output
Physical Interface		
Physical interface	Name of the physical interface.	All levels
Interface index	Index number of the physical interface, which reflects its initialization sequence.	detail extensive none
Device flags	Information about the physical device.	All levels
Flow control	Flow control status: Enabled or Disabled . NOTE: This field is only displayed if asymmetric flow control is not configured.	All levels
Pad to minimum frame size	Pad Tx VLAN-tagged frame to minimum of 68 bytes.	
Device flags	Information about the physical device.	All levels
Interface flags	Information about the interface.	All levels
Current address	Configured MAC address.	detail extensive none
Last flapped	Date, time, and how long ago the interface went from down to up. The format is Last flapped: <i>year-month-day hour:minute.second.timezone (hour:minute.second ago)</i> . For example, Last flapped: 2008-01-16 10:52:40 UTC (3d 22:58 ago) .	detail extensive none

Table 38: show interfaces extensive satellite-device Output Fields (Continued)

Field Name	Field Description	Level of Output
Statistics last cleared	Time when the statistics for the interface were last set to zero.	detail extensive
Extended port information	Satellite device port ID	
Traffic statistics	<p>Number and rate of bytes and packets received and transmitted on the physical interface.</p> <ul style="list-style-type: none"> • Input bytes—Number of bytes received on the interface. • Output bytes—Number of bytes transmitted on the interface. • Input packets—Number of packets received on the interface. • Output packets—Number of packets transmitted on the interface. <p>NOTE: The bandwidth bps counter is not enabled.</p>	detail extensive
IPv6 transit statistics	<p>Number and rate of bytes and packets received and transmitted on the physical interface.</p> <ul style="list-style-type: none"> • Input bytes—Number of bytes received on the interface. • Output bytes—Number of bytes transmitted on the interface. • Input packets—Number of packets received on the interface. • Output packets—Number of packets transmitted on the interface. <p>NOTE: The bandwidth bps counter is not enabled.</p>	detail extensive

Table 38: show interfaces extensive satellite-device Output Fields (*Continued*)

Field Name	Field Description	Level of Output
Input errors	<p>Input errors on the interface. The following paragraphs explain the counters whose meaning might not be obvious:</p> <ul style="list-style-type: none"> • Errors—Sum of the incoming frame terminates and FCS errors. • Drops—Number of packets dropped by the input queue of the I/O Manager ASIC. If the interface is saturated, this number increments once for every packet that is dropped by the ASIC's RED mechanism. • Framing errors—Number of packets received with an invalid frame checksum (FCS). • Runts—Number of frames received that are smaller than the runt threshold. • Giants—Number of frames received that are greater than the giant threshold. • Policed discards—Number of frames that the incoming packet match code discarded because they were not recognized or not of interest. Usually, this field reports protocols that Junos OS does not handle. • Resource errors—Sum of transmit drops. 	extensive

Table 38: show interfaces extensive satellite-device Output Fields (Continued)

Field Name	Field Description	Level of Output
Output errors	<p>Output errors on the interface. The following paragraphs explain the counters whose meaning might not be obvious:</p> <ul style="list-style-type: none"> • Carrier transitions—Number of times the interface has gone from down to up. This number does not normally increment quickly, increasing only when the cable is unplugged, the far-end system is powered down and then up, or another problem occurs. If the number of carrier transitions increments quickly (perhaps once every 10 seconds), the cable, the far-end system, or the PIC or PIM is malfunctioning. • Errors—Sum of the outgoing frame terminates and FCS errors. • Drops—Number of packets dropped by the output queue of the I/O Manager ASIC. If the interface is saturated, this number increments once for every packet that is dropped by the ASIC's RED mechanism. • MTU errors—Number of packets whose size exceeded the MTU of the interface. • Resource errors—Sum of transmit drops. 	extensive
Egress queues	Total number of egress queues supported on the specified interface.	detail extensive
Queue counters	<p>CoS queue number and its associated user-configured forwarding class name.</p> <ul style="list-style-type: none"> • Queued packets—Number of queued packets. • Transmitted packets—Number of transmitted packets. • Dropped packets—Number of packets dropped by the ASIC's RED mechanism. 	detail extensive
Queue Number	The CoS queue number and the forwarding classes mapped to the queue number. The Mapped forwarding class column lists the forwarding classes mapped to each CoS queue.	detail extensive

Table 38: show interfaces extensive satellite-device Output Fields (Continued)

Field Name	Field Description	Level of Output
Active alarms and Active defects	<p>Ethernet-specific defects that can prevent the interface from passing packets. When a defect persists for a certain amount of time, it is promoted to an alarm. Based on the switch configuration, an alarm can ring the red or yellow alarm bell on the switch, or turn on the red or yellow alarm LED on the craft interface. These fields can contain the value None or Link.</p> <ul style="list-style-type: none"> • None—There are no active defects or alarms. • Link—Interface has lost its link state, which usually means that the cable is unplugged, the far-end system has been turned off, or the PIC is malfunctioning. 	detail extensive none

Table 38: show interfaces extensive satellite-device Output Fields (*Continued*)

Field Name	Field Description	Level of Output
MAC statistics	<p>Receive and Transmit statistics reported by the PIC's MAC subsystem.</p> <ul style="list-style-type: none"> • Total octets and total packets—Total number of octets and packets. For Gigabit Ethernet IQ PICs, the received octets count varies by interface type. • Unicast packets, Broadcast packets, and Multicast packets—Number of unicast, broadcast, and multicast packets. • CRC/Align errors—Total number of packets received that had a length (excluding framing bits, but including FCS octets) of between 64 and 1518 octets, inclusive, and had either a bad FCS with an integral number of octets (FCS Error) or a bad FCS with a nonintegral number of octets (Alignment Error). • FIFO error—Number of FIFO errors that are reported by the ASIC on the PIC. If this value is ever nonzero, the PIC is probably malfunctioning. • MAC control frames—Number of MAC control frames. • MAC pause frames—Number of MAC control frames with pause operational code. • Oversized frames—Number of packets that exceeds the configured MTU. • Jabber frames—Number of frames that were longer than 1518 octets (excluding framing bits, but including FCS octets), and had either an FCS error or an alignment error. This definition of jabber is different from the definition in IEEE-802.3 section 8.2.1.5 (10BASE5) and section 10.3.1.4 (10BASE2). These documents define jabber as the condition in which any packet exceeds 20 ms. The allowed range to detect jabber is from 20 ms to 150 ms. • Fragment frames—Total number of packets that were less than 64 octets in length (excluding framing bits, but including FCS octets), and had either an FCS error or an alignment error. Fragment frames normally increment because both runts (which are normal occurrences caused by collisions) and noise hits are counted. 	extensive

Table 38: show interfaces extensive satellite-device Output Fields (Continued)

Field Name	Field Description	Level of Output
	<ul style="list-style-type: none"> • VLAN tagged frames—Number of frames that are VLAN tagged. The system uses the TPID of 0x8100 in the frame to determine whether a frame is tagged or not. This counter is not supported on EX Series switches and is always displayed as 0. • Code violations—Number of times an event caused the PHY to indicate “Data reception error” or “invalid data symbol error.” 	
Filter statistics	Receive and Transmit statistics reported by the PIC's MAC address filter subsystem.	extensive
Packet Forwarding Engine configuration	Information about the configuration of the Packet Forwarding Engine: <ul style="list-style-type: none"> • Destination slot—FPC slot number. • CoS transmit queue—Queue number and its associated user-configured forwarding class name. • Bandwidth %—Percentage of bandwidth allocated to the queue. • Bandwidth bps—Bandwidth allocated to the queue (in bps). • Buffer %—Percentage of buffer space allocated to the queue. • Buffer usec—Amount of buffer space allocated to the queue, in microseconds. This value is nonzero only if the buffer size is configured in terms of time. • Priority—Queue priority: low or high. • Limit—Displayed if rate limiting is configured for the queue. Possible values are none and exact. If exact is configured, the queue transmits only up to the configured bandwidth, even if excess bandwidth is available. If none is configured, the queue transmits beyond the configured bandwidth if bandwidth is available. 	extensive
Logical Interface		
Logical interface	Name of the logical interface.	All levels

Table 38: show interfaces extensive satellite-device Output Fields (Continued)

Field Name	Field Description	Level of Output
Index	Index number of the logical interface, which reflects its initialization sequence.	detail extensive none
SNMP ifIndex	SNMP interface index number for the logical interface.	detail extensive none
Generation	Unique number for use by Juniper Networks technical support only.	detail extensive
Flags	Information about the logical interface.	All levels
Statistics	<ul style="list-style-type: none"> • Packets • pps • Bytes • bps 	All levels
Bundle	<p>Provide information for each active bundle link.</p> <ul style="list-style-type: none"> • Input <ul style="list-style-type: none"> • Packets— • pps • Bytes • bps • Output <ul style="list-style-type: none"> • Packets— • pps • Bytes • bps 	All levels

Table 38: show interfaces extensive satellite-device Output Fields (Continued)

Field Name	Field Description	Level of Output
Adaptive Statistics	<ul style="list-style-type: none"> • Adaptive Adjusts • Adaptive Scans • Adaptive Updates 	All levels
Link	Link state: up or down.	All levels
LACP info	<p>LACP state information for each aggregated interface:</p> <ul style="list-style-type: none"> • Role priority—Role played by the interface. It can be one of the following: <ul style="list-style-type: none"> • Actor—Local device participating in LACP negotiation. • Partner—Remote device participating in LACP negotiation. • System identifier—48-bit (6-byte) globally unique field. • System priority—LACP system priority at the aggregated Ethernet interface level. This system priority value takes precedence over a system priority value configured at the global [edit chassis] hierarchy level. • Port number • Port key • Port 	All levels
LACP Statistics	<p>LACP statistics are returned when the extensive option is used and provides the following information:</p> <ul style="list-style-type: none"> • LACP Rx—LACP received counter that increments for each normal hello. • LACP Tx—Number of LACP transmit packet errors logged. • Unknown Rx—Number of unrecognized packet errors logged. • Illegal Rx—Number of invalid packets received. 	All levels

Table 38: show interfaces extensive satellite-device Output Fields (Continued)

Field Name	Field Description	Level of Output
Marker statistics	<p>Marker statistics are returned when the extensive option is used and provides the following information:</p> <ul style="list-style-type: none"> • Marker Rx—Marker received counter that increments for each normal hello. • Resp Tx—Number of RESP transmit packet errors logged. • Unknown Rx—Number of unrecognized packet errors logged. • Illegal Rx—Number of invalid packets received. 	All levels
Protocol	Protocol family configured on the logical interface.	All levels
MTU	MTU size on the logical interface. If the MTU value is negotiated down to meet the MRRU requirement on the remote side, this value is marked Adjusted.	All levels
Generation	Unique number for use by Juniper Networks technical support only.	All levels
Route table	Routing table in which this address exists. For example, Route table:0 refers to inet.0.	All levels
Mesh table	Information regarding mesh topology.	All levels

Sample Output

show interfaces extensive satellite-device all

```

user@aggregation-device> show interfaces extensive satellite-device all
Physical interface: ae0 (Extended Port, Enabled, Physical link is Up
  Interface index: 128, SNMP ifIndex: 574, Generation: 131
  Link-level type: Ethernet, MTU: 1514, Speed: 2Gbps, BPDU Error: None, MAC-REWRITE Error: None,
  Loopback: Disabled, Source filtering: Disabled,
  Flow control: Disabled

```

```

Pad to minimum frame size: Disabled
Minimum links needed: 1, Minimum bandwidth needed: 1bps
Device flags   : Present Running
Interface flags: SNMP-Traps Internal: 0x4000
Current address: f4:b5:2f:f7:3f:c0, Hardware address: f4:b5:2f:f7:3f:c0
Last flapped   : 2015-03-31 18:36:43 PDT (07:05:56 ago)
Statistics last cleared: Never
Extended port information:
  Satellite device port id : 415
Traffic statistics:
  Input bytes   :          13515908          2032 bps
  Output bytes  :          12289920          2032 bps
  Input packets:           99514           2 pps
  Output packets:          96015           2 pps
IPv6 transit statistics:
  Input bytes   :              0
  Output bytes  :              0
  Input packets:              0
  Output packets:             0
Input errors:
  Errors: 0, Drops: 0, Framing errors: 0, Runts: 0, Giants: 0, Policed discards: 0, Resource
errors: 0
Output errors:
  Carrier transitions: 0, Errors: 0, Drops: 0, MTU errors: 0, Resource errors: 0
Egress queues: 8 supported, 7 in use
Queue counters:      Queued packets  Transmitted packets      Dropped packets
  0                   0                95867                    0
  1                   0                0                        0
  2                   0                0                        0
  3                   0                0                        0
  4                   0                0                        0
  5                   0                0                        0
  7                   0                0                        0
Queue number:      Mapped forwarding classes
  0                FC0
  1                FC1
  2                FC2
  3                FC3
  4                FC4
  5                FC5, be-3
  7                be-2

Logical interface ae0.0 (Index 337) (SNMP ifIndex 575) (Generation 1194)

```

Flags: Up SNMP-Traps 0x24024000 Encapsulation: Ethernet-Bridge

Statistics	Packets	pps	Bytes	bps
------------	---------	-----	-------	-----

Bundle:

Input :	1729	0	601692	0
Output:	0	0	0	0

Adaptive Statistics:

Adaptive Adjusts:	0
Adaptive Scans :	0
Adaptive Updates:	0

Link:

ge-104/0/24.0

Input :	0	0	0	0
Output:	0	0	0	0

ge-103/0/0.0

Input :	1729	0	601692	0
Output:	0	0	0	0

LACP info:	Role	System priority	System identifier	Port priority	Port number	Port key
ge-104/0/24.0	Actor	127	f4:b5:2f:f7:3f:c0	127	31	1
ge-104/0/24.0	Partner	127	f4:b5:2f:41:0a:40	127	24	1
ge-103/0/0.0	Actor	127	f4:b5:2f:f7:3f:c0	127	7	1
ge-103/0/0.0	Partner	127	f4:b5:2f:41:0a:40	127	1	1

LACP Statistics:	LACP Rx	LACP Tx	Unknown Rx	Illegal Rx
------------------	---------	---------	------------	------------

ge-104/0/24.0	25470	25495	0	0
ge-103/0/0.0	25469	25512	0	0

Marker Statistics:	Marker Rx	Resp Tx	Unknown Rx	Illegal Rx
--------------------	-----------	---------	------------	------------

ge-104/0/24.0	0	0	0	0
ge-103/0/0.0	0	0	0	0

Protocol bridge, MTU: 1514, Generation: 1229, Route table: 3, Mesh Group: __all_ces__

Physical interface: ae1 (Extended Port, Enabled, Physical link is Up

Interface index: 129, SNMP ifIndex: 790, Generation: 132

Link-level type: Ethernet, MTU: 1514, Speed: 200mbps, BPDU Error: None, MAC-REWRITE Error: None, Loopback: Disabled, Source filtering: Disabled,

Flow control: Disabled

Pad to minimum frame size: Disabled

Minimum links needed: 1, Minimum bandwidth needed: 1bps

Device flags : Present Running

Interface flags: SNMP-Traps Internal: 0x4000

Current address: f4:b5:2f:f7:3f:c1, Hardware address: f4:b5:2f:f7:3f:c1

Last flapped : 2015-03-31 18:36:44 PDT (07:05:55 ago)

Statistics last cleared: Never

Extended port information:

Satellite device port id : 431

Traffic statistics:

```

Input bytes :          13285288          2032 bps
Output bytes :          12166400          2032 bps
Input packets:          98447            2 pps
Output packets:         95050            2 pps

```

IPv6 transit statistics:

```

Input bytes :          0
Output bytes :          0
Input packets:         0
Output packets:        0

```

Input errors:

Errors: 0, Drops: 0, Framing errors: 0, Runts: 0, Giants: 0, Policed discards: 0, Resource errors: 0

Output errors:

Carrier transitions: 0, Errors: 0, Drops: 0, MTU errors: 0, Resource errors: 0

Egress queues: 8 supported, 7 in use

Queue counters:	Queued packets	Transmitted packets	Dropped packets
0	0	94909	0
1	0	0	0
2	0	0	0
3	0	0	0
4	0	0	0
5	0	0	0
7	0	0	0

Queue number: Mapped forwarding classes

```

0      FC0
1      FC1
2      FC2
3      FC3
4      FC4
5      FC5, be-3
7      be-2

```

Logical interface ae1.0 (Index 338) (SNMP ifIndex 1216) (Generation 1195)

Flags: Up SNMP-Traps 0x24024000 Encapsulation: Ethernet-Bridge

Statistics	Packets	pps	Bytes	bps
------------	---------	-----	-------	-----

Bundle:

Input :	2785	0	688380	0
Output:	0	0	0	0

Adaptive Statistics:

```

Adaptive Adjusts:      0
Adaptive Scans :      0
Adaptive Updates:     0

```

Link:

```

ge-104/0/25.0
  Input :           10           0           600           0
  Output:           0           0           0           0
ge-103/0/1.0
  Input :          2775           0          687780           0
  Output:           0           0           0           0
LACP info:         Role      System          System      Port   Port  Port
                   priority  identifier  priority  number  key
ge-104/0/25.0    Actor      127 f4:b5:2f:f7:3f:c0    127    32    2
ge-104/0/25.0    Partner   127 f4:b5:2f:41:0a:40    127    25    2
ge-103/0/1.0     Actor      127 f4:b5:2f:f7:3f:c0    127     8    2
ge-103/0/1.0     Partner   127 f4:b5:2f:41:0a:40    127     2    2
LACP Statistics:  LACP Rx    LACP Tx    Unknown Rx  Illegal Rx
ge-104/0/25.0    25470      25494      0           0
ge-103/0/1.0    25469      25513      0           0
Marker Statistics: Marker Rx    Resp Tx    Unknown Rx  Illegal Rx
ge-104/0/25.0    0           0           0           0
ge-103/0/1.0    0           0           0           0

```

Protocol bridge, MTU: 1514, Generation: 1230, Route table: 3, Mesh Group: __all_ces__

Physical interface: ae0 (Extended Port, Enabled, Physical link is Up)

Interface index: 128, SNMP ifIndex: 574, Generation: 131

Link-level type: Ethernet, MTU: 1514, Speed: 2Gbps, BPDU Error: None, MAC-REWRITE Error: None,

Loopback: Disabled, Source filtering: Disabled,

Flow control: Disabled

Pad to minimum frame size: Disabled

Minimum links needed: 1, Minimum bandwidth needed: 1bps

Device flags : Present Running

Interface flags: SNMP-Traps Internal: 0x4000

Current address: f4:b5:2f:f7:3f:c0, Hardware address: f4:b5:2f:f7:3f:c0

Last flapped : 2015-03-31 18:36:43 PDT (07:05:56 ago)

Statistics last cleared: Never

Extended port information:

Satellite device port id : 415

Traffic statistics:

```

Input bytes :           13515908           2032 bps
Output bytes :           12289920           2032 bps
Input packets:           99514           2 pps
Output packets:          96015           2 pps

```

IPv6 transit statistics:

```

Input bytes :           0
Output bytes :           0
Input packets:           0

```

```

Output packets:          0
Input errors:
  Errors: 0, Drops: 0, Framing errors: 0, Runts: 0, Giants: 0, Policed discards: 0, Resource
errors: 0
Output errors:
  Carrier transitions: 0, Errors: 0, Drops: 0, MTU errors: 0, Resource errors: 0
Egress queues: 8 supported, 7 in use
Queue counters:          Queued packets  Transmitted packets  Dropped packets
0                        0                95867                0
1                        0                0                    0
2                        0                0                    0
3                        0                0                    0
4                        0                0                    0
5                        0                0                    0
7                        0                0                    0
Queue number:           Mapped forwarding classes
0                       FC0
1                       FC1
2                       FC2
3                       FC3
4                       FC4
5                       FC5, be-3
7                       be-2

Logical interface ae0.0 (Index 337) (SNMP ifIndex 575) (Generation 1194)
Flags: Up SNMP-Traps 0x24024000 Encapsulation: Ethernet-Bridge
Statistics          Packets          pps          Bytes          bps
Bundle:
  Input :           1729           0           601692         0
  Output:            0           0             0             0
Adaptive Statistics:
  Adaptive Adjusts: 0
  Adaptive Scans  : 0
  Adaptive Updates: 0
Link:
  ge-104/0/24.0
  Input :           0           0             0             0
  Output:            0           0             0             0
  ge-103/0/0.0
  Input :           1729           0           601692         0
  Output:            0           0             0             0
LACP info:          Role      System          System      Port      Port      Port
                   priority  priority  identifier  priority  number  key

```

```

ge-104/0/24.0 Actor      127 f4:b5:2f:f7:3f:c0      127 31 1
ge-104/0/24.0 Partner    127 f4:b5:2f:41:0a:40      127 24 1
ge-103/0/0.0 Actor      127 f4:b5:2f:f7:3f:c0      127 7 1
ge-103/0/0.0 Partner    127 f4:b5:2f:41:0a:40      127 1 1
LACP Statistics:      LACP Rx      LACP Tx      Unknown Rx   Illegal Rx
ge-104/0/24.0        25470        25495        0            0
ge-103/0/0.0        25469        25512        0            0
Marker Statistics:   Marker Rx      Resp Tx      Unknown Rx   Illegal Rx
ge-104/0/24.0        0            0            0            0
ge-103/0/0.0        0            0            0            0
Protocol bridge, MTU: 1514, Generation: 1229, Route table: 3, Mesh Group: __all_ces__
Physical interface: ae1 (Extended Port, Enabled, Physical link is Up
Interface index: 129, SNMP ifIndex: 790, Generation: 132
Link-level type: Ethernet, MTU: 1514, Speed: 200mbps, BPDU Error: None, MAC-REWRITE Error:
None, Loopback: Disabled, Source filtering: Disabled,
Flow control: Disabled
Pad to minimum frame size: Disabled
Minimum links needed: 1, Minimum bandwidth needed: 1bps
Device flags   : Present Running
Interface flags: SNMP-Traps Internal: 0x4000
Current address: f4:b5:2f:f7:3f:c1, Hardware address: f4:b5:2f:f7:3f:c1
Last flapped   : 2015-03-31 18:36:44 PDT (07:05:55 ago)
Statistics last cleared: Never
Extended port information:
  Satellite device port id : 431
Traffic statistics:
Input bytes :          13285288          2032 bps
Output bytes :          12166400          2032 bps
Input packets:           98447           2 pps
Output packets:          95050           2 pps
IPv6 transit statistics:
Input bytes :           0
Output bytes :           0
Input packets:           0
Output packets:           0
Input errors:
Errors: 0, Drops: 0, Framing errors: 0, Runts: 0, Giants: 0, Policed discards: 0, Resource
errors: 0
Output errors:
Carrier transitions: 0, Errors: 0, Drops: 0, MTU errors: 0, Resource errors: 0
Egress queues: 8 supported, 7 in use
Queue counters:      Queued packets  Transmitted packets  Dropped packets
0                    0                    94909                0

```

1	0	0	0
2	0	0	0
3	0	0	0
4	0	0	0
5	0	0	0
7	0	0	0

Queue number: Mapped forwarding classes

0	FC0
1	FC1
2	FC2
3	FC3
4	FC4
5	FC5, be-3
7	be-2

Logical interface ae1.0 (Index 338) (SNMP ifIndex 1216) (Generation 1195)

Flags: Up SNMP-Traps 0x24024000 Encapsulation: Ethernet-Bridge

Statistics	Packets	pps	Bytes	bps
------------	---------	-----	-------	-----

Bundle:

Input :	2785	0	688380	0
Output:	0	0	0	0

Adaptive Statistics:

Adaptive Adjusts:	0
Adaptive Scans :	0
Adaptive Updates:	0

Link:

ge-104/0/25.0

Input :	10	0	600	0
Output:	0	0	0	0

ge-103/0/1.0

Input :	2775	0	687780	0
Output:	0	0	0	0

LACP info:	Role	System priority	System identifier	Port priority	Port number	Port key
ge-104/0/25.0	Actor	127	f4:b5:2f:f7:3f:c0	127	32	2
ge-104/0/25.0	Partner	127	f4:b5:2f:41:0a:40	127	25	2
ge-103/0/1.0	Actor	127	f4:b5:2f:f7:3f:c0	127	8	2
ge-103/0/1.0	Partner	127	f4:b5:2f:41:0a:40	127	2	2

LACP Statistics:	LACP Rx	LACP Tx	Unknown Rx	Illegal Rx
------------------	---------	---------	------------	------------

ge-104/0/25.0	25470	25494	0	0
---------------	-------	-------	---	---

ge-103/0/1.0	25469	25513	0	0
--------------	-------	-------	---	---

Marker Statistics:	Marker Rx	Resp Tx	Unknown Rx	Illegal Rx
--------------------	-----------	---------	------------	------------

ge-104/0/25.0	0	0	0	0
---------------	---	---	---	---

```

ge-103/0/1.0          0          0          0          0
Protocol bridge, MTU: 1514, Generation: 1230, Route table: 3, Mesh Group: __all_ces__

Physical interface: ae0 (Extended Port, Enabled, Physical link is Up
  Interface index: 128, SNMP ifIndex: 574, Generation: 131
  Link-level type: Ethernet, MTU: 1514, Speed: 2Gbps, BPDU Error: None, MAC-REWRITE Error: None,
Loopback: Disabled, Source filtering: Disabled,
  Flow control: Disabled
  Pad to minimum frame size: Disabled
  Minimum links needed: 1, Minimum bandwidth needed: 1bps
  Device flags   : Present Running
  Interface flags: SNMP-Traps Internal: 0x4000
  Current address: f4:b5:2f:f7:3f:c0, Hardware address: f4:b5:2f:f7:3f:c0
  Last flapped   : 2015-03-31 18:36:43 PDT (07:05:56 ago)
  Statistics last cleared: Never
  Extended port information:
    Satellite device port id : 415
  Traffic statistics:
    Input bytes   :          13515908          2032 bps
    Output bytes  :          12289920          2032 bps
    Input packets :          99514          2 pps
    Output packets:          96015          2 pps
  IPv6 transit statistics:
    Input bytes   :          0
    Output bytes  :          0
    Input packets :          0
    Output packets:          0
  Input errors:
    Errors: 0, Drops: 0, Framing errors: 0, Runts: 0, Giants: 0, Policed discards: 0, Resource
errors: 0
  Output errors:
    Carrier transitions: 0, Errors: 0, Drops: 0, MTU errors: 0, Resource errors: 0
  Egress queues: 8 supported, 7 in use
  Queue counters:
    Queued packets  Transmitted packets  Dropped packets
    0                0                95867            0
    1                0                0                0
    2                0                0                0
    3                0                0                0
    4                0                0                0
    5                0                0                0
    7                0                0                0
  Queue number:    Mapped forwarding classes
    0              FC0

```

```

1          FC1
2          FC2
3          FC3
4          FC4
5          FC5, be-3
7          be-2

```

Logical interface ae0.0 (Index 337) (SNMP ifIndex 575) (Generation 1194)

Flags: Up SNMP-Traps 0x24024000 Encapsulation: Ethernet-Bridge

Statistics	Packets	pps	Bytes	bps
------------	---------	-----	-------	-----

Bundle:

Input :	1729	0	601692	0
Output:	0	0	0	0

Adaptive Statistics:

Adaptive Adjusts:	0
Adaptive Scans :	0
Adaptive Updates:	0

Link:

ge-104/0/24.0

Input :	0	0	0	0
Output:	0	0	0	0

ge-103/0/0.0

Input :	1729	0	601692	0
Output:	0	0	0	0

LACP info:	Role	System priority	System identifier	Port priority	Port number	Port key
ge-104/0/24.0	Actor	127	f4:b5:2f:f7:3f:c0	127	31	1
ge-104/0/24.0	Partner	127	f4:b5:2f:41:0a:40	127	24	1
ge-103/0/0.0	Actor	127	f4:b5:2f:f7:3f:c0	127	7	1
ge-103/0/0.0	Partner	127	f4:b5:2f:41:0a:40	127	1	1

LACP Statistics:	LACP Rx	LACP Tx	Unknown Rx	Illegal Rx
------------------	---------	---------	------------	------------

ge-104/0/24.0	25470	25495	0	0
ge-103/0/0.0	25469	25512	0	0

Marker Statistics:	Marker Rx	Resp Tx	Unknown Rx	Illegal Rx
--------------------	-----------	---------	------------	------------

ge-104/0/24.0	0	0	0	0
ge-103/0/0.0	0	0	0	0

Protocol bridge, MTU: 1514, Generation: 1229, Route table: 3, Mesh Group: __all_ces__

Physical interface: ae1 (Extended Port, Enabled, Physical link is Up

Interface index: 129, SNMP ifIndex: 790, Generation: 132

Link-level type: Ethernet, MTU: 1514, Speed: 200Mbps, BPDU Error: None, MAC-REWRITE Error: None, Loopback: Disabled, Source filtering: Disabled,

Flow control: Disabled

Pad to minimum frame size: Disabled

```

Minimum links needed: 1, Minimum bandwidth needed: 1bps
Device flags   : Present Running
Interface flags: SNMP-Traps Internal: 0x4000
Current address: f4:b5:2f:f7:3f:c1, Hardware address: f4:b5:2f:f7:3f:c1
Last flapped   : 2015-03-31 18:36:44 PDT (07:05:55 ago)
Statistics last cleared: Never
Extended port information:
  Satellite device port id : 431
Traffic statistics:
Input bytes   :           13285288           2032 bps
Output bytes  :           12166400           2032 bps
Input packets:           98447           2 pps
Output packets:          95050           2 pps
IPv6 transit statistics:
Input bytes   :           0
Output bytes  :           0
Input packets:           0
Output packets:          0
Input errors:
  Errors: 0, Drops: 0, Framing errors: 0, Runts: 0, Giants: 0, Policed discards: 0, Resource
errors: 0
Output errors:
  Carrier transitions: 0, Errors: 0, Drops: 0, MTU errors: 0, Resource errors: 0
Egress queues: 8 supported, 7 in use
Queue counters:      Queued packets  Transmitted packets  Dropped packets
  0                   0                94909                 0
  1                   0                0                     0
  2                   0                0                     0
  3                   0                0                     0
  4                   0                0                     0
  5                   0                0                     0
  7                   0                0                     0
Queue number:      Mapped forwarding classes
  0                 FC0
  1                 FC1
  2                 FC2
  3                 FC3
  4                 FC4
  5                 FC5, be-3
  7                 be-2

Logical interface ae1.0 (Index 338) (SNMP ifIndex 1216) (Generation 1195)
Flags: Up SNMP-Traps 0x24024000 Encapsulation: Ethernet-Bridge

```



```

Statistics          Packets      pps          Bytes          bps
Bundle:
  Input :           2785          0         688380          0
  Output:            0          0           0           0
Adaptive Statistics:
  Adaptive Adjusts:    0
  Adaptive Scans :    0
  Adaptive Updates:   0
Link:
  ge-104/0/25.0
    Input :           10          0          600           0
    Output:            0          0           0           0
  ge-103/0/1.0
    Input :           2775          0         687780          0
    Output:            0          0           0           0
LACP info:          Role      System          System      Port      Port      Port
                   priority  identifier  priority  number  key
  ge-104/0/25.0   Actor      127 f4:b5:2f:f7:3f:c0  127      32      2
  ge-104/0/25.0   Partner    127 f4:b5:2f:41:0a:40  127      25      2
  ge-103/0/1.0    Actor      127 f4:b5:2f:f7:3f:c0  127       8      2
  ge-103/0/1.0    Partner    127 f4:b5:2f:41:0a:40  127       2      2
LACP Statistics:   LACP Rx    LACP Tx    Unknown Rx    Illegal Rx
  ge-104/0/25.0   25470      25494      0             0
  ge-103/0/1.0   25469      25513      0             0
Marker Statistics: Marker Rx    Resp Tx    Unknown Rx    Illegal Rx
  ge-104/0/25.0    0          0          0             0
  ge-103/0/1.0    0          0          0             0
Protocol bridge, MTU: 1514, Generation: 1230, Route table: 3, Mesh Group: __all_ces__
Physical interface: ge-101/0/7 (Extended Port, Enabled, Physical link is Down)
Interface index: 328, SNMP ifIndex: 1587, Generation: 331
Link-level type: Ethernet, MTU: 1514, LAN-PHY mode, Speed: 1000mbps
Device flags   : Present Running
Interface flags: Hardware-Down SNMP-Traps Internal: 0x4000
Link flags     : None
CoS queues     : 8 supported, 8 maximum usable queues
Hold-times     : Up 0 ms, Down 0 ms
Damping        : half-life: 0 sec, max-suppress: 0 sec, reuse: 0, suppress: 0, state:
unsuppressed
Current address: 10:0e:7e:bf:2d:0c, Hardware address: 10:0e:7e:bf:2d:0c
Last flapped   : Never
Statistics last cleared: Never
Extended port information:
  Satellite device port id : 143

```

Traffic statistics:

```

Input bytes :           0           0 bps
Output bytes :          0           0 bps
Input packets:          0           0 pps
Output packets:         0           0 pps

```

IPv6 transit statistics:

```

Input bytes :           0
Output bytes :           0
Input packets:           0
Output packets:          0

```

Input errors:

```

Errors: 0, Drops: 0, Framing errors: 0, Runts: 0, Policed discards: 0, L3 incompletes: 0, L2
channel errors: 0, L2 mismatch timeouts: 0, FIFO errors: 0,
Resource errors: 0

```

Output errors:

```

Carrier transitions: 0, Errors: 0, Drops: 0, Collisions: 0, Aged packets: 0, FIFO errors: 0,
HS link CRC errors: 0, MTU errors: 0, Resource errors: 0

```

Egress queues: 8 supported, 7 in use

Queue counters:	Queued packets	Transmitted packets	Dropped packets
0	0	0	0
1	0	0	0
2	0	0	0
3	0	0	0
4	0	0	0
5	0	0	0
7	0	0	0

Queue number: Mapped forwarding classes

```

0           FC0
1           FC1
2           FC2
3           FC3
4           FC4
5           FC5, be-3
7           be-2

```

Active alarms : None

Active defects : None

MAC statistics:	Receive	Transmit
Total octets	0	0
Total packets	0	0
Unicast packets	0	0
Broadcast packets	0	0
Multicast packets	0	0
CRC/Align errors	0	0

```

FIFO errors                0                0
MAC control frames        0                0
MAC pause frames         0                0
Oversized frames         0
Jabber frames            0
Fragment frames          0
VLAN tagged frames       0
Code violations           0
Total errors              0                0

```

Filter statistics:

```

Input packet count        0
Input packet rejects      0
Input DA rejects          0
Input SA rejects          0
Output packet count       0
Output packet pad count   0
Output packet error count 0

```

CAM destination filters: 0, CAM source filters: 0

Packet Forwarding Engine configuration:

Destination slot: 0 (0x00)

CoS information:

Direction : Output

CoS transmit queue		Bandwidth		Buffer	Priority	Limit
	%	bps	%	usec		
0 FC0	95	950000000	95	0	low	none
3 FC3	5	50000000	5	0	low	none

Interface transmit statistics: Disabled

Physical interface: ge-101/0/8 (Extended Port, Enabled, Physical link is Down)

Interface index: 329, SNMP ifIndex: 1586, Generation: 332

Link-level type: Ethernet, MTU: 1514, LAN-PHY mode, Speed: 1000mbps

Device flags : Present Running

Interface flags: Hardware-Down SNMP-Traps Internal: 0x4000

Link flags : None

CoS queues : 8 supported, 8 maximum usable queues

Hold-times : Up 0 ms, Down 0 ms

Damping : half-life: 0 sec, max-suppress: 0 sec, reuse: 0, suppress: 0, state:

unsuppressed

Current address: 10:0e:7e:bf:2d:0d, Hardware address: 10:0e:7e:bf:2d:0d

Last flapped : Never

Statistics last cleared: Never

Extended port information:

Satellite device port id : 159

Traffic statistics:

```

Input bytes :           0           0 bps
Output bytes :          0           0 bps
Input packets:          0           0 pps
Output packets:         0           0 pps

```

IPv6 transit statistics:

```

Input bytes :           0
Output bytes :          0
Input packets:          0
Output packets:         0

```

Input errors:

Errors: 0, Drops: 0, Framing errors: 0, Runts: 0, Policed discards: 0, L3 incompletes: 0, L2 channel errors: 0, L2 mismatch timeouts: 0, FIFO errors: 0, Resource errors: 0

Output errors:

Carrier transitions: 0, Errors: 0, Drops: 0, Collisions: 0, Aged packets: 0, FIFO errors: 0, HS link CRC errors: 0, MTU errors: 0, Resource errors: 0

Egress queues: 8 supported, 7 in use

Queue counters:	Queued packets	Transmitted packets	Dropped packets
0	0	0	0
1	0	0	0
2	0	0	0
3	0	0	0
4	0	0	0
5	0	0	0
7	0	0	0

Queue number: Mapped forwarding classes

```

0           FC0
1           FC1
2           FC2
3           FC3
4           FC4
5           FC5, be-3
7           be-2

```

Active alarms : None

Active defects : None

MAC statistics:	Receive	Transmit
Total octets	0	0
Total packets	0	0
Unicast packets	0	0
Broadcast packets	0	0
Multicast packets	0	0
CRC/Align errors	0	0

```

FIFO errors                0                0
MAC control frames        0                0
MAC pause frames         0                0
Oversized frames         0
Jabber frames            0
Fragment frames          0
VLAN tagged frames       0
Code violations           0
Total errors             0                0
Filter statistics:
  Input packet count      0
  Input packet rejects    0
  Input DA rejects        0
  Input SA rejects        0
  Output packet count     0
  Output packet pad count 0
  Output packet error count 0
  CAM destination filters: 0, CAM source filters: 0
Packet Forwarding Engine configuration:
  Destination slot: 0 (0x00)
CoS information:
  Direction : Output
  CoS transmit queue      Bandwidth          Buffer Priority  Limit
                           %          bps      %          usec
  0 FC0                    95      950000000  95          0      low  none
  3 FC3                     5       500000000   5          0      low  none
Interface transmit statistics: Disabled

```

Release Information

Command introduced in Junos OS Release 14.2R3.

RELATED DOCUMENTATION

| [Configuring or Expanding a Junos Fusion Enterprise](#)

show interfaces satellite-device

IN THIS SECTION

- [Syntax | 731](#)
- [Description | 731](#)
- [Options | 731](#)
- [Required Privilege Level | 731](#)
- [Output Fields | 732](#)
- [Sample Output | 735](#)
- [Sample Output | 736](#)
- [Release Information | 738](#)

Syntax

```
show interfaces satellite-device (device-alias | all)
```

Description

Display the satellite device extended ports in a Junos Fusion.

Options

- | | |
|--|--|
| device-alias
<i>device-alias</i> | Display extended port information for the satellite device using the specified device alias only. |
| all | Display information for all extended ports and aggregated Ethernet interfaces with extended ports as members configured on all of the satellite devices. |

Required Privilege Level

view

Output Fields

Table 39 on page 732 lists the output fields for the `show interfaces satellite-device` command. Output fields are listed in the approximate order in which they appear.

Table 39: show interfaces satellite-device Output Fields

Field Name	Field Description	Level of Output
Physical Interface		
Physical interface	Name of the physical interface.	All levels
Interface index	Index number of the physical interface, which reflects its initialization sequence.	detail extensive none
Link-level type	Encapsulation being used on the physical interface.	All levels
Device flags	Information about the physical device.	All levels
Flow control	Flow control status: Enabled or Disabled . NOTE: This field is only displayed if asymmetric flow control is not configured.	All levels
Pad to minimum frame size	Pad Tx VLAN-tagged frame to minimum of 68 bytes.	All levels
Minimum links needed	Minimum number of aggregated links.	All levels
Minimum bandwidth needed	Minimum bandwidth configured for aggregated bundle.	All levels
Device flags	Information about the physical device.	All levels

Table 39: show interfaces satellite-device Output Fields (Continued)

Field Name	Field Description	Level of Output
Interface flags	Information about the interface.	All levels
Current address	Configured MAC address.	detail extensive none
Last flapped	Date, time, and how long ago the interface went from down to up. The format is Last flapped: year-month-day hour:minute.second.timezone (hour:minute.second ago) . For example, Last flapped: 2008-01-16 10:52:40 UTC (3d 22:58 ago) .	detail extensive none
Input rate	Input rate in bits per second (bps) and packets per second (pps). The value in this field also includes the Layer 2 overhead bytes for ingress traffic on Ethernet interfaces if you enable accounting of Layer 2 overhead at the PIC level or the logical interface level.	All levels
Output rate	Output rate in bps and pps. The value in this field also includes the Layer 2 overhead bytes for egress traffic on Ethernet interfaces if you enable accounting of Layer 2 overhead at the PIC level or the logical interface level.	All levels
Extended port information	Satellite device port ID	All levels
Active alarms and Active defects	<p>Ethernet-specific defects that can prevent the interface from passing packets. When a defect persists for a certain amount of time, it is promoted to an alarm. Based on the switch configuration, an alarm can ring the red or yellow alarm bell on the switch, or turn on the red or yellow alarm LED on the craft interface. These fields can contain the value None or Link.</p> <ul style="list-style-type: none"> • None—There are no active defects or alarms. • Link—Interface has lost its link state, which usually means that the cable is unplugged, the far-end system has been turned off, or the PIC is malfunctioning. 	detail extensive none

Table 39: show interfaces satellite-device Output Fields (Continued)

Field Name	Field Description	Level of Output
Interface transmit statistics	All levels	All levels
Logical Interface		
Logical interface	Name of the logical interface.	All levels
Index	Index number of the logical interface, which reflects its initialization sequence.	detail extensive none
SNMP ifIndex	SNMP interface index number for the logical interface.	detail extensive none
Generation	Unique number for use by Juniper Networks technical support only.	detail extensive
Flags	Information about the logical interface.	All levels
Statistics	<ul style="list-style-type: none"> • Packets • pps • Bytes • bps 	All levels

Table 39: show interfaces satellite-device Output Fields (Continued)

Field Name	Field Description	Level of Output
Bundle	<p>Provides information for each active bundle link.</p> <ul style="list-style-type: none"> • Input <ul style="list-style-type: none"> • Packets • pps • Bytes • bps • Output <ul style="list-style-type: none"> • Packets— • pps • Bytes • bps 	All levels
Adaptive Statistics	<ul style="list-style-type: none"> • Adaptive Adjusts • Adaptive Scans • Adaptive Updates 	All levels
Protocol	Protocol family configured on the logical interface.	All levels

Sample Output

Sample Output

show interfaces satellite-device all

```

user@aggregation-device> show interfaces satellite-device all
Physical interface: ae0 (Extended Port, Enabled, Physical link is Up
  Interface index: 128, SNMP ifIndex: 574
  Link-level type: Ethernet, MTU: 1514, Speed: 2Gbps, BPDU Error: None, MAC-REWRITE Error: None,
Loopback: Disabled, Source filtering: Disabled,
  Flow control: Disabled
  Pad to minimum frame size: Disabled
  Minimum links needed: 1, Minimum bandwidth needed: 1bps
  Device flags   : Present Running
  Interface flags: SNMP-Traps Internal: 0x4000
  Current address: f4:b5:2f:f7:3f:c0, Hardware address: f4:b5:2f:f7:3f:c0
  Last flapped   : 2015-03-31 18:36:43 PDT (06:54:08 ago)
  Input rate     : 2032 bps (2 pps)
  Output rate    : 3048 bps (2 pps)

Logical interface ae0.0 (Index 337) (SNMP ifIndex 575)
  Flags: Up SNMP-Traps 0x24024000 Encapsulation: Ethernet-Bridge
  Statistics      Packets      pps      Bytes      bps
  Bundle:
    Input :          1704          0      592992          0
    Output:           0           0           0           0
  Adaptive Statistics:
    Adaptive Adjusts:          0
    Adaptive Scans  :          0
    Adaptive Updates:          0
  Protocol bridge, MTU: 1514

Physical interface: ae1 (Extended Port, Enabled, Physical link is Up
  Interface index: 129, SNMP ifIndex: 790
  Link-level type: Ethernet, MTU: 1514, Speed: 200mbps, BPDU Error: None, MAC-REWRITE Error:
None, Loopback: Disabled, Source filtering: Disabled,
  Flow control: Disabled
  Pad to minimum frame size: Disabled
  Minimum links needed: 1, Minimum bandwidth needed: 1bps
  Device flags   : Present Running
  Interface flags: SNMP-Traps Internal: 0x4000
  Current address: f4:b5:2f:f7:3f:c1, Hardware address: f4:b5:2f:f7:3f:c1
  Last flapped   : 2015-03-31 18:36:44 PDT (06:54:07 ago)

```

Input rate : 2032 bps (2 pps)
 Output rate : 2032 bps (2 pps)

Logical interface ae1.0 (Index 338) (SNMP ifIndex 1216)

Flags: Up SNMP-Traps 0x24024000 Encapsulation: Ethernet-Bridge

Statistics	Packets	pps	Bytes	bps
------------	---------	-----	-------	-----

Bundle:

Input :	2759	0	679982	0
---------	------	---	--------	---

Output:	0	0	0	0
---------	---	---	---	---

Adaptive Statistics:

Adaptive Adjusts: 0

Adaptive Scans : 0

Adaptive Updates: 0

Protocol bridge, MTU: 1514

Physical interface: xe-101/0/31 (Extended Port, Enabled, Physical link is Up

Interface index: 336, SNMP ifIndex: 829

Link-level type: Ethernet, MTU: 1514, LAN-PHY mode, Speed: 10Gbps

Device flags : Present Running

Interface flags: SNMP-Traps Internal: 0x4000

Link flags : None

CoS queues : 8 supported, 8 maximum usable queues

Current address: 10:0e:7e:bf:2d:24, Hardware address: 10:0e:7e:bf:2d:24

Last flapped : 2015-03-31 08:28:23 PDT (17:02:29 ago)

Input rate : 0 bps (0 pps)

Output rate : 0 bps (0 pps)

Active alarms : None

Active defects : None

Interface transmit statistics: Disabled

Logical interface xe-101/0/31.0 (Index 491) (SNMP ifIndex 926)

Flags: Up SNMP-Traps 0x24024000 Encapsulation: Ethernet-Bridge

Input packets : 0

Output packets: 0

Protocol bridge, MTU: 1514

Physical interface: xe-101/0/32 (Extended Port, Enabled, Physical link is Up

Interface index: 337, SNMP ifIndex: 836

Link-level type: Ethernet, MTU: 1514, LAN-PHY mode, Speed: 10Gbps

Device flags : Present Running

Interface flags: SNMP-Traps Internal: 0x4000

Link flags : None

CoS queues : 8 supported, 8 maximum usable queues

Current address: 10:0e:7e:bf:2d:25, Hardware address: 10:0e:7e:bf:2d:25

```
Last flapped   : 2015-03-31 08:28:23 PDT (17:02:29 ago)
Input rate    : 0 bps (0 pps)
Output rate   : 0 bps (0 pps)
Active alarms : None
Active defects : None
Interface transmit statistics: Disabled

Logical interface xe-101/0/32.0 (Index 492) (SNMP ifIndex 935)
  Flags: Up SNMP-Traps 0x24024000 Encapsulation: Ethernet-Bridge
  Input packets : 0
  Output packets: 0
  Protocol bridge, MTU: 1514
```

Release Information

Command introduced in Junos OS Release 14.2R3.

RELATED DOCUMENTATION

| [Configuring or Expanding a Junos Fusion Enterprise](#)

show interfaces statistics

IN THIS SECTION

- [Syntax | 739](#)
- [Description | 739](#)
- [Options | 739](#)
- [Required Privilege Level | 739](#)
- [Output Fields | 740](#)
- [Sample Output | 740](#)
- [Release Information | 756](#)

Syntax

```
show interfaces statistics interface-name
<satellite-device [device-alias-name |all ]>
<detail>
```

Description

Display static interface statistics, such as errors.

NOTE: When the **show interfaces statistics** command is executed on an interface that is configured on T4000 Type 5 FPC, the *IPv6 transit statistics* field displays:

- Total statistics (sum of transit and local statistics) at the physical interface level
- Transit statistics at the logical interface level

Options

<i>interface-name</i>	Name of an interface.
satellite-device [<i>device-alias-name</i> all]	(Junos Fusion only) (Optional) Display interface statistics for interfaces on the specified satellite device in the Junos Fusion, or on all satellite devices in the Junos Fusion.

NOTE: In a Junos Fusion Enterprise, logical interface statistics are not synced across aggregation devices in a dual-aggregation device topology.

detail	(Optional) Display detailed output.
---------------	-------------------------------------

Required Privilege Level

view

Output Fields

Output from both the `show interfaces interface-name detail` and the `show interfaces interface-name extensive` commands include all the information displayed in the output from the `show interfaces statistics` command. For more information, see the particular interface type in which you are interested. For information about destination class and source class statistics, see the “Destination Class Field” section and the “Source Class Field” section under [Common Output Fields Description](#). For information about the input errors and output errors, see [Fast Ethernet and Gigabit Ethernet Counters](#).

Sample Output

show interfaces statistics (Fast Ethernet)

```

user@host> show interfaces fe-1/3/1 statistics
Physical interface: fe-1/3/1, Enabled, Physical link is Up
  Interface index: 144, SNMP ifIndex: 1042
  Description: ford fe-1/3/1
  Link-level type: Ethernet, MTU: 1514, Speed: 100mbps, Loopback: Disabled,
  Source filtering: Disabled, Flow control: Enabled
  Device flags   : Present Running
  Interface flags: SNMP-Traps Internal: 0x4000
  CoS queues    : 4 supported, 4 maximum usable queues
  Current address: 00:00:5E:00:53:dc, Hardware address: 00:00:5E:00:53:dc
  Last flapped  : 2006-04-18 03:08:59 PDT (00:01:24 ago)
  Statistics last cleared: Never
  Input rate    : 0 bps (0 pps)
  Output rate   : 0 bps (0 pps)
  Input errors: 0, Output errors: 0
  Active alarms : None
  Active defects : None
Logical interface fe-1/3/1.0 (Index 69) (SNMP ifIndex 50)
  Flags: SNMP-Traps Encapsulation: ENET2
  Protocol inet, MTU: 1500
    Flags: Is-Primary, DCU, SCU-in

```

Destination class	Packets (packet-per-second)	Bytes (bits-per-second)
silver1	0	0
(0)	(
silver2	0	0
(0)	(
silver3	0	0

```

(
0) (
0)
Addresses, Flags: Is-Default Is-Preferred Is-Primary
Destination: 10.27.245/24, Local: 10.27.245.2,
Broadcast: 10.27.245.255
Protocol iso, MTU: 1497
Flags: Is-Primary

```

show interfaces statistics (Gigabit Ethernet PIC—Egress)

```

user@host> show interfaces ge-5/2/0 statistics detail
Physical interface: ge-5/2/0, Enabled, Physical link is Up
Interface index: 146, SNMP ifIndex: 519, Generation: 149
Link-level type: Ethernet, MTU: 1514, Speed: 1000mbps, BPDU Error: None, MAC-REWRITE Error:
None, Loopback: Disabled,
Source filtering: Disabled, Flow control: Enabled, Auto-negotiation: Enabled, Remote fault:
Online
Device flags   : Present Running
Interface flags: SNMP-Traps Internal: 0x4000
Link flags     : None
CoS queues    : 8 supported, 8 maximum usable queues
Hold-times    : Up 0 ms, Down 0 ms
Current address: 00:00:5E:00:53:74, Hardware address: 00:00:5E:00:53:74
Last flapped  : 2009-11-11 11:24:00 PST (09:23:08 ago)
Statistics last cleared: 2009-11-11 17:50:58 PST (02:56:10 ago)
Traffic statistics:
Input bytes   :           271524           0 bps
Output bytes  :          37769598          352 bps
Input packets :           3664           0 pps
Output packets:          885790           0 pps
IPv6 transit statistics:
Input bytes   :              0
Output bytes  :          16681118
Input packets :              0
Output packets:          362633
Multicast statistics:
IPV4 multicast statistics:
Input bytes   :          112048           0 bps
Output bytes  :         20779920           0 bps
Input packets :           1801           0 pps
Output packets:         519498           0 pps
IPV6 multicast statistics:

```



```

Input bytes :          156500          0 bps
Output bytes :        16681118          0 bps
Input packets:         1818           0 pps
Output packets:       362633           0 pps

```

Input errors:

Errors: 0, Drops: 0, Framing errors: 0, Runts: 0, Policed discards: 0, L3 incompletes: 0, L2 channel errors: 0,

L2 mismatch timeouts: 0, FIFO errors: 0, Resource errors: 0

Output errors:

Carrier transitions: 0, Errors: 0, Drops: 0, Collisions: 0, Aged packets: 0, FIFO errors: 0, HS link CRC errors: 0, MTU errors: 0,

Resource errors: 0

Egress queues: 8 supported, 4 in use

Queue counters:	Queued packets	Transmitted packets	Dropped packets
0 best-effort	882558	882558	0
1 expedited-fo	0	0	0
2 assured-forw	0	0	0
3 network-cont	3232	3232	0

Active alarms : None

Active defects : None

Logical interface ge-5/2/0.0 (Index 71) (SNMP ifIndex 573) (Generation 135)

Flags: SNMP-Traps 0x4000 Encapsulation: ENET2

Egress account overhead: 100

Ingress account overhead: 90

Traffic statistics:

```

Input bytes :          271524
Output bytes :        37769598
Input packets:         3664
Output packets:       885790

```

IPv6 transit statistics:

```

Input bytes :          0
Output bytes :        16681118
Input packets:         0
Output packets:       362633

```

Local statistics:

```

Input bytes :          271524
Output bytes :        308560
Input packets:         3664
Output packets:       3659

```

Transit statistics:

```

Input bytes :          0          0 bps
Output bytes :       37461038       0 bps

```

```

Input packets:          0          0 pps
Output packets:        882131      0 pps
IPv6 transit statistics:
  Input bytes  :          0
  Output bytes :       16681118
  Input packets:         0
  Output packets:      362633
Multicast statistics:
  IPV4 multicast statistics:
    Input bytes  :       112048      0 bps
    Output bytes :     20779920      0 bps
    Input packets:       1801        0 pps
    Output packets:    519498        0 pps
  IPV6 multicast statistics:
    Input bytes  :       156500      0 bps
    Output bytes :     16681118      0 bps
    Input packets:       1818        0 pps
    Output packets:    362633        0 pps
Protocol inet, MTU: 1500, Generation: 151, Route table: 0
  Addresses, Flags: Is-Preferred Is-Primary
    Destination: 10.40.40.0/30, Local: 10.40.40.2, Broadcast: 10.40.40.3, Generation: 167
Protocol inet6, MTU: 1500, Generation: 152, Route table: 0
  Addresses, Flags: Is-Preferred Is-Primary
    Destination: ::10.40.40.0/126, Local: ::10.40.40.2
Generation: 169
  Addresses, Flags: Is-Preferred
    Destination: fe80::/64, Local: fe80::21d:b5ff:fe61:d974
Protocol multiservice, MTU: Unlimited, Generation: 171
Generation: 153, Route table: 0
  Policer: Input: __default_arp_policer__

```

show interfaces statistics detail (Aggregated Ethernet)

```

user@host> show interfaces ae0 detail
Physical interface: ae0, Enabled, Physical link is Up
  Interface index: 186, SNMP ifIndex: 111, Generation: 187
  Link-level type: Ethernet, MTU: 1514, Speed: 2000mbps, Loopback: Disabled,
  Source filtering: Disabled, Flow control: Disabled, Minimum links needed: 1,
  Minimum bandwidth needed: 0
  Device flags   : Present Running

```

```

Interface flags: SNMP-Traps Internal: 0x4000
Current address: 00:00:5E:0053:f0, Hardware address: 00:00:5E:00:53:f0
Last flapped   : Never
Statistics last cleared: 2006-12-23 03:04:16 PST (01:16:24 ago)
Traffic statistics:
Input bytes   :           28544           0 bps
Output bytes  :           39770           0 bps
Input packets :            508           0 pps
Output packets:            509           0 pps
Input bytes   :           IPv6 28544
Output bytes  :           IPv6 0
Input packets :           IPv6 508
Output packets:           IPv6 0
Input errors:
  Errors: 0, Drops: 0, Framing errors: 0, Runts: 0, Giants: 0,
  Policed discards: 0, Resource errors: 0
Output errors:
  Carrier transitions: 0, Errors: 0, Drops: 0, MTU errors: 0,
  Resource errors: 0

Logical interface ae0.0 (Index 67) (SNMP ifIndex 139) (Generation 145)
Flags: SNMP-Traps Encapsulation: ENET2
Statistics      Packets      pps      Bytes      bps
Bundle:
  Input :         508         0      28544       0
  Output:         509         0      35698       0
Link:
  ge-3/3/8.0
  Input :         508         0      28544       0
  Output:          0         0         0         0
  ge-3/3/9.0
  Input :          0         0         0         0
  Output:          0         0         0         0
Marker Statistics:  Marker Rx    Resp Tx    Unknown Rx  Illegal Rx
  ge-3/3/8.0         0         0         0         0
  ge-3/3/9.0         0         0         0         0
Egress queues: 8 supported, 8 in use
Queue counters:      Queued packets  Transmitted packets  Dropped packets
  0 best-effort         0             0                   0
  1 expedited-fo       0             0                   0
  2 assured-forw       0             0                   0
  3 network-cont       0             0                   0
Protocol inet, MTU: 1500, Generation: 166, Route table: 0

```

```

Flags: None
Addresses, Flags: Is-Preferred Is-Primary
  Destination: 10.1.1/24, Local: 10.1.1.1, Broadcast: 10.1.1.255,
  Generation: 159
Protocol inet6, MTU: 1500, Generation: 163, Route table: 0
Flags: Is-Primary
Addresses, Flags: Is-Preferred
  Destination: fe80::/64, Local: fe80::206:5bff:fe05:c321,
  Broadcast: Unspecified, Generation: 161

```

show interfaces statistics detail (Aggregated Ethernet—Ingress)

```

user@host> show interfaces statistics detail ae0 | no-more
Physical interface: ae0, Enabled, Physical link is Up
  Interface index: 128, SNMP ifIndex: 504, Generation: 278
  Link-level type: Ethernet, MTU: 1514, Speed: 1Gbps, BPDU Error: None, MAC-REWRITE Error: None,
Loopback: Disabled,
  Source filtering: Disabled, Flow control: Disabled, Minimum links needed: 1, Minimum bandwidth
needed: 0
  Device flags   : Present Running
  Interface flags: SNMP-Traps Internal: 0x4000
  Current address: 00:00:5E:00:53:f0, Hardware address: 00:00:5E:00:53:f0
  Last flapped   : 2009-11-09 03:30:23 PST (00:01:28 ago)
  Statistics last cleared: 2009-11-09 03:26:18 PST (00:05:33 ago)
Traffic statistics:
  Input bytes   :          544009602          54761856 bps
  Output bytes  :           3396          0 bps
  Input packets:          11826292          148809 pps
  Output packets:           42          0 pps
IPv6 transit statistics:
  Input bytes   :          350818604
  Output bytes  :           0
  Input packets:          7626488
  Output packets:           0
Input errors:
  Errors: 0, Drops: 0, Framing errors: 0, Runts: 0, Giants: 0, Policed discards: 0, Resource
errors: 0
Output errors:
  Carrier transitions: 0, Errors: 0, Drops: 0, MTU errors: 0, Resource errors: 0
Ingress queues: 8 supported, 4 in use
Queue counters:      Queued packets  Transmitted packets  Dropped packets

```

```

0 best-effort          0          0          0
1 expedited-fo        0          0          0
2 assured-forw        0          0          0
3 network-cont        0          0          0
Egress queues: 8 supported, 4 in use
Queue counters:      Queued packets  Transmitted packets    Dropped packets
0 best-effort        21          21          0
1 expedited-fo        0          0          0
2 assured-forw        0          0          0
3 network-cont       451         451         0

Logical interface ae0.0 (Index 70) (SNMP ifIndex 574) (Generation 177)
Flags: SNMP-Traps 0x4000 Encapsulation: ENET2
Statistics          Packets      pps          Bytes          bps
Bundle:
  Input :           11826292    148809      544009602     54761856
  Output:              42         0           3396          0
Link:
  ge-5/2/0.0
  Input :           11826292    148809      544009602     54761856
  Output:              42         0           3396          0
Marker Statistics:  Marker Rx    Resp Tx    Unknown Rx    Illegal Rx
ge-5/2/0.0          0           0           0             0
Protocol inet, MTU: 1500, Generation: 236, Route table: 0
Addresses, Flags: Is-Preferred Is-Primary
  Destination: 10.30.30.0/30, Local: 10.30.30.2, Broadcast: 10.30.30.3, Generation: 310
Protocol inet6, MTU: 1500, Generation: 237, Route table: 0
Addresses, Flags: Is-Preferred Is-Primary
  Destination: ::10.30.30.0/126, Local: ::10.30.30.2
Generation: 312
Addresses, Flags: Is-Preferred
  Destination: fe80::/64, Local: fe80::21d:b5ff:fe61:dbf0
Protocol multiservice, MTU: Unlimited, Generation: 314
Generation: 238, Route table: 0
Policer: Input: __default_arp_policer__

```

show interfaces statistics detail (Aggregated Ethernet—Egress)

```

user@host> show interfaces statistics detail ae0 | no-more
Physical interface: ae0, Enabled, Physical link is Up
Interface index: 128, SNMP ifIndex: 501, Generation: 319

```

Link-level type: Ethernet, MTU: 1514, Speed: 1Gbps, BPDU Error: None, MAC-REWRITE Error: None, Loopback: Disabled,

Source filtering: Disabled, Flow control: Disabled, Minimum links needed: 1, Minimum bandwidth needed: 0

Device flags : Present Running

Interface flags: SNMP-Traps Internal: 0x4000

Current address: 00:00:5E:00:53:f0, Hardware address: 00:00:5E:00:53:f0

Last flapped : 2009-11-09 03:30:24 PST (00:02:42 ago)

Statistics last cleared: 2009-11-09 03:26:42 PST (00:06:24 ago)

Traffic statistics:

Input bytes :	440	0 bps
Output bytes :	1047338120	54635848 bps
Input packets:	7	0 pps
Output packets:	22768200	148466 pps

IPv6 transit statistics:

Input bytes :	288
Output bytes :	723202616
Input packets:	4
Output packets:	15721796

Input errors:

Errors: 0, Drops: 0, Framing errors: 0, Runts: 0, Giants: 0, Policed discards: 0, Resource errors: 0

Output errors:

Carrier transitions: 0, Errors: 0, Drops: 0, MTU errors: 0, Resource errors: 0

Ingress queues: 8 supported, 4 in use

Queue counters:	Queued packets	Transmitted packets	Dropped packets
0 best-effort	0	0	0
1 expedited-fo	0	0	0
2 assured-forw	0	0	0
3 network-cont	0	0	0

Egress queues: 8 supported, 4 in use

Queue counters:	Queued packets	Transmitted packets	Dropped packets
0 best-effort	201985796	201985796	0
1 expedited-fo	0	0	0
2 assured-forw	0	0	0
3 network-cont	65	65	0

Logical interface ae0.0 (Index 72) (SNMP ifIndex 505) (Generation 204)

Flags: SNMP-Traps 0x4000 Encapsulation: ENET2

Statistics	Packets	pps	Bytes	bps
------------	---------	-----	-------	-----

Bundle:

Input :	7	0	440	0
Output:	22768200	148466	1047338120	54635848

```

Link:
  ge-2/1/6.0
    Input :           7           0           440           0
    Output:    22768200    148466    1047338120    54635848
Marker Statistics:  Marker Rx    Resp Tx    Unknown Rx    Illegal Rx
  ge-2/1/6.0           0           0           0           0
Protocol inet, MTU: 1500, Generation: 291, Route table: 0
  Addresses, Flags: Is-Preferred Is-Primary
    Destination: 10.30.30.0/30, Local: 10.30.30.1, Broadcast: 10.30.30.3, Generation: 420
Protocol inet6, MTU: 1500, Generation: 292, Route table: 0
  Addresses, Flags: Is-Preferred Is-Primary
    Destination: ::/26, Local: ::10.30.30.1
Generation: 422
  Addresses, Flags: Is-Preferred
    Destination: fe80::/64, Local: fe80::21f:12ff:fec2:37f0
Protocol multiservice, MTU: Unlimited, Generation: 424
Generation: 293, Route table: 0
  Policer: Input: __default_arp_policer__

```

show interfaces statistics (SONET/SDH)

```

user@host> show interfaces statistics detail so-3/0/0 | no-more
Physical interface: so-3/0/0, Enabled, Physical link is Up
  Interface index: 133, SNMP ifIndex: 538, Generation: 283
  Link-level type: PPP, MTU: 4474, Clocking: Internal, SONET mode, Speed: OC192, Loopback: None,
  FCS: 16, Payload scrambler: Enabled
  Device flags   : Present Running
  Interface flags: Point-To-Point SNMP-Traps Internal: 0x4000
  Link flags     : Keepalives
  Hold-times    : Up 0 ms, Down 0 ms
  Keepalive settings: Interval 10 seconds, Up-count 1, Down-count 3
  Keepalive statistics:
    Input : 13 (last seen 00:00:04 ago)
    Output: 14 (last sent 00:00:02 ago)
  LCP state: Opened
  NCP state: inet: Opened, inet6: Opened, iso: Not-configured, mpls: Not-configured
  CHAP state: Closed
  PAP state: Closed
  CoS queues   : 8 supported, 8 maximum usable queues
  Last flapped : 2009-11-09 02:52:34 PST (01:12:39 ago)
  Statistics last cleared: 2009-11-09 03:58:54 PST (00:06:19 ago)

```

Traffic statistics:

```

Input bytes :          2559160294          54761720 bps
Output bytes :           10640             48 bps
Input packets:         55633975          148809 pps
Output packets:         216              0 pps

```

IPv6 transit statistics:

```

Input bytes :          647922328
Output bytes :           0
Input packets:         14085269
Output packets:         0

```

Input errors:

Errors: 0, Drops: 0, Framing errors: 0, Runts: 0, Giants: 0, Bucket drops: 0, Policed discards: 0, L3 incompletes: 0,

L2 channel errors: 0, L2 mismatch timeouts: 0, HS link CRC errors: 0, HS link FIFO overflows: 0

Output errors:

Carrier transitions: 0, Errors: 0, Drops: 0, Aged packets: 0, HS link FIFO underflows: 0, MTU errors: 0

Egress queues: 8 supported, 4 in use

Queue counters:	Queued packets	Transmitted packets	Dropped packets
0 best-effort	4	4	0
1 expedited-fo	0	0	0
2 assured-forw	0	0	0
3 network-cont	213	213	0

SONET alarms : None

SONET defects : None

Logical interface so-3/0/0.0 (Index 72) (SNMP ifIndex 578) (Generation 182)

Flags: Point-To-Point SNMP-Traps 0x4000 Encapsulation: PPP

Protocol inet, MTU: 4470, Generation: 244, Route table: 0

Addresses, Flags: Is-Preferred Is-Primary

Destination: 10.30.30.0/30, Local: 10.30.30.2, Broadcast: 10.30.30.3, Generation: 322

Protocol inet6, MTU: 4470, Generation: 245, Route table: 0

Addresses, Flags: Is-Preferred Is-Primary

Destination: ::10.30.30.0/126, Local: ::10.30.30.2

Generation: 324

Addresses, Flags: Is-Preferred

Destination: fe80::/64, Local: fe80::2a0:a5ff:fe61:9264

Generation: 326

show interfaces statistics (Aggregated SONET/SDH—Ingress)

```

user@host> show interfaces statistics detail as0 | no-more
Physical interface: as0, Enabled, Physical link is Up
  Interface index: 132, SNMP ifIndex: 534, Generation: 282
  Link-level type: PPP, MTU: 4474, Speed: OC192, Minimum links needed: 1, Minimum bandwidth
needed: 0
  Device flags   : Present Running
  Interface flags: SNMP-Traps Internal: 0x4000
  Link flags     : Keepalives
  Keepalive settings: Interval 10 seconds, Up-count 1, Down-count 3
  Last flapped   : 2009-11-09 03:45:53 PST (00:09:38 ago)
  Statistics last cleared: 2009-11-09 03:48:17 PST (00:07:14 ago)
  Traffic statistics:
    Input bytes   :          2969786332          54761688 bps
    Output bytes  :           11601             0 bps
    Input packets :          64560636          148808 pps
    Output packets:           225             0 pps
  IPv6 transit statistics:
    Input bytes   :          2086013152
    Output bytes  :              0
    Input packets :          45348114
    Output packets:              0
  Input errors:
    Errors: 0, Drops: 0, Framing errors: 0, Runts: 0, Giants: 0, Policed discards: 0, Resource
errors: 0
  Output errors:
    Carrier transitions: 0, Errors: 0, Drops: 0, MTU errors: 0, Resource errors: 0
  Egress queues: 8 supported, 4 in use
  Queue counters:
    Queued packets  Transmitted packets  Dropped packets
    0 best-effort   3                    3                    0
    1 expedited-fo  0                    0                    0
    2 assured-forw  0                    0                    0
    3 network-cont  222                  222                  0

Logical interface as0.0 (Index 71) (SNMP ifIndex 576) (Generation 179)
  Flags: Point-To-Point SNMP-Traps 0x4000 Encapsulation: PPP
  Statistics
    Packets      pps      Bytes      bps
  Bundle:
    Input :      64560550    148808    2969785300    54761688
    Output:       139         0         10344         0
  Link:

```

```

so-3/0/0.0
  Input :      64560550      148808      2969785300      54761688
  Output:         139         0         10344         0
Protocol inet, MTU: 4470, Generation: 240, Route table: 0
  Addresses, Flags: Is-Preferred Is-Primary
    Destination: 10.30.30.0/30, Local: 10.30.30.2, Broadcast: 10.30.30.3, Generation: 316
Protocol inet6, MTU: 4470, Generation: 241, Route table: 0
  Addresses, Flags: Is-Preferred Is-Primary
    Destination: ::10.30.30.0/126, Local: ::10.30.30.2
Generation: 318
  Addresses, Flags: Is-Preferred
    Destination: fe80::/64, Local: fe80::2a0:a5ff:fe61:9264
Generation: 320

```

show interfaces statistics (Aggregated SONET/SDH—Egress)

```

user@host> show interfaces statistics detail as0 | no-more
Physical interface: as0, Enabled, Physical link is Up
  Interface index: 132, SNMP ifIndex: 565, Generation: 323
  Link-level type: PPP, MTU: 4474, Speed: OC192, Minimum links needed: 1, Minimum bandwidth
needed: 0
  Device flags   : Present Running
  Interface flags: SNMP-Traps Internal: 0x4000
  Link flags     : Keepalives
  Keepalive settings: Interval 10 seconds, Up-count 1, Down-count 3
  Last flapped   : 2009-11-09 03:43:37 PST (00:12:48 ago)
  Statistics last cleared: 2009-11-09 03:48:54 PST (00:07:31 ago)
  Traffic statistics:
    Input bytes   :           11198           392 bps
    Output bytes  :      3101452132      54783448 bps
    Input packets :           234           0 pps
    Output packets:      67422937      148868 pps
  IPv6 transit statistics:
    Input bytes   :           5780
    Output bytes  :      2171015678
    Input packets :           72
    Output packets:      47195993
  Input errors:
    Errors: 0, Drops: 0, Framing errors: 0, Runts: 0, Giants: 0, Policed discards: 0, Resource
errors: 0
  Output errors:

```

```

Carrier transitions: 0, Errors: 0, Drops: 0, MTU errors: 0, Resource errors: 0
Egress queues: 8 supported, 4 in use
Queue counters:      Queued packets  Transmitted packets  Dropped packets
 0 best-effort        67422830             67422830             0
 1 expedited-fo       0                    0                    0
 2 assured-forw       0                    0                    0
 3 network-cont       90                   90                   0

Logical interface as0.0 (Index 71) (SNMP ifIndex 548) (Generation 206)
Flags: Point-To-Point SNMP-Traps 0x4000 Encapsulation: PPP
Statistics      Packets      pps      Bytes      bps
Bundle:
  Input :        144          0      10118      392
  Output:    67422847    148868  3101450962  54783448
Link:
  so-0/1/0.0
  Input :        144          0      10118      392
  Output:    67422847    148868  3101450962  54783448
Protocol inet, MTU: 4470, Generation: 295, Route table: 0
  Addresses, Flags: Is-Preferred Is-Primary
    Destination: 10.30.30.0/30, Local: 10.30.30.1, Broadcast: 10.30.30.3, Generation: 426
Protocol inet6, MTU: 4470, Generation: 296, Route table: 0
  Addresses, Flags: Is-Preferred Is-Primary
    Destination: ::/26, Local: ::10.30.30.1
Generation: 428
  Addresses, Flags: Is-Preferred
    Destination: fe80::/64, Local: fe80::2a0:a5ff:fe63:1d0a
Generation: 429

```

show interfaces statistics (MX Series Routers)

```

user@host> show interfaces xe-0/0/0 statistics
Physical interface: xe-0/0/0, Enabled, Physical link is Up
Interface index: 145, SNMP ifIndex: 592
Link-level type: Ethernet, MTU: 1514, LAN-PHY mode, Speed: 10Gbps, BPDU Error: None, Loopback:
None, Source filtering: Disabled, Flow control: Enabled
Pad to minimum frame size: Enabled
Device flags   : Present Running
Interface flags: SNMP-Traps Internal: 0x0
Link flags     : None
CoS queues     : 8 supported, 8 maximum usable queues

```

```

Current address: 00:00:5E:00:53:f0, Hardware address: 00:00:5E:00:53:f0
Last flapped   : 2013-10-26 03:20:40 test (2w3d 03:29 ago)
Statistics last cleared: Never
Input rate     : 0 bps (0 pps)
Output rate    : 0 bps (0 pps)
Input errors: 0, Output errors: 0
Active alarms  : LINK
Active defects : LINK
PCS statistics          Seconds
  Bit errors           109
  Errored blocks       109
Interface transmit statistics: Disabled

```

show interfaces statistics (MX Series Routers; With RPF Check Detail of Ethernet Interface)

```

user@host> show interfaces ge-0/0/0 extensive
Physical interface: ge-0/0/0, Enabled, Physical link is Up
  Interface index: 149, SNMP ifIndex: 527, Generation: 152
  Link-level type: Ethernet, MTU: 1514, MRU: 1522, LAN-PHY mode, Speed: 1000mbps, BPDU Error:
None, Loop Detect PDU Error: None,
  Ethernet-Switching Error: None, MAC-REWRITE Error: None, Loopback: Disabled, Source filtering:
Disabled, Flow control: Enabled, Auto-negotiation: Enabled,
  Remote fault: Online
  Pad to minimum frame size: Disabled
  Device flags   : Present Running
  Interface Specific flags: RPF_statistics
  Interface flags: SNMP-Traps Internal: 0x4000
  Link flags     : None
  CoS queues    : 8 supported, 8 maximum usable queues
  Hold-times    : Up 0 ms, Down 0 ms
  Damping       : half-life: 0 sec, max-suppress: 0 sec, reuse: 0, suppress: 0, state:
unsuppressed
  Current address: 56:68:ad:c0:1f:72, Hardware address: 56:68:ad:c0:1f:72
  Last flapped   : 2021-02-12 17:21:37 IST (3d 15:55 ago)
  Statistics last cleared: Never
  Traffic statistics:
    Input bytes   :                0                0 bps
    Output bytes  :                0                0 bps
    Input packets :                0                0 pps
    Output packets:                0                0 pps
  IPv6 transit statistics:

```

```

Input bytes : 0
Output bytes : 0
Input packets: 0
Output packets: 0
Dropped traffic statistics due to STP State:
Input bytes : 0
Output bytes : 0
Input packets: 0
Output packets: 0
Input errors:
  Errors: 0, Drops: 0, Framing errors: 0, Runts: 0, Policed discards: 0, L3 incompletes: 0, L2
channel errors: 0, L2 mismatch timeouts: 0, FIFO errors: 0,
  Resource errors: 0
Output errors:
  Carrier transitions: 1, Errors: 0, Drops: 0, Collisions: 0, Aged packets: 0, FIFO errors: 0,
HS link CRC errors: 0, MTU errors: 0, Resource errors: 0
RPF counters statistics:
Rpf IPv4 bytes : 0
Rpf IPv4 packets : 0
Rpf IPv6 bytes : 0
Rpf IPv6 packets : 0
Active alarms : None
Active defects : None
PCS statistics          Seconds
Bit errors              0
Errored blocks          0

```

show interfaces statistics (MX Series Routers: Dynamic Interfaces with RPF Check Detail)

```

user@host> show interfaces statistics pp0.3221225475 detail
Logical interface pp0.3221225475(Index 536870921)(SNMP ifIndex 200000009) (Generation 6)
Flags: Up Point-To-Point Encapsulation: PPPoE
PPPoE:
  State: SessionUp, Session ID: 1,
  Session AC name: B, Remote MAC address:00:00:5E:00:53:01,
  Underlying interface: xe-1/0/0.3221225474 (Index 536870919)
  Ignore End-Of-List tag: Disable
Bandwidth: 0
Traffic statistics:
Input bytes : 34
Output bytes : 0

```

```

Input packets:          1
Output packets:        1
Local statistics:
Input bytes  :          0
Output bytes  :          0
Input packets:         0
Output packets:        0
Transit statistics:
Input bytes  :          34          0 bps
Output bytes  :           0          0 bps
Input packets:         1          0 pps
Output packets:        1          0 pps
Keepalive settings: Interval 30 seconds, Up-count 3, Down-count 3
LCP state: Opened
NCP state: inet: Opened, inet6: Not-configured, iso: Not-configured, mpls: Not-configured
CHAP state: Success
PAP state: Closed
Protocol inet, MTU: 1492
Max nh cache: 0, New hold nh limit: 0, Curr nh cnt: 0, Curr new hold cnt: 0, NH drop cnt: 0
Generation: 0, Route table: 0
Flags: uRPF, Unnumbered
RPF Failures: Packets: 0, Bytes: 0
Donor interface: lo0.0 (Index 320)
Input Filters: upstrm1-inet-pp0.3221225475-in
Output Filters: dwnstrm1-inet-pp0.3221225475-out
Addresses, Flags: Is-Primary
Destination: Unspecified, Local: 10.255.96.19, Broadcast: Unspecified, Generation: 0

```

show interfaces statistics (PTX Series Packet Transport Routers)

```

user@host> show interfaces statistics em0
Physical interface: em0, Enabled, Physical link is Up
Interface index: 8, SNMP ifIndex: 0
Type: Ethernet, Link-level type: Ethernet, MTU: 1514, Speed: 1000mbps
Device flags   : Present Running
Interface flags: SNMP-Traps
Link type      : Full-Duplex
Current address: 00:00:5E:00:53:1b, Hardware address: 00:00:5E:00:53:1b
Last flapped   : Never
Statistics last cleared: Never
Input packets  : 212620

```

```

Output packets: 71
  Input errors: 0, Output errors: 0

  Logical interface em0.0 (Index 3) (SNMP ifIndex 0)
  Flags: SNMP-Traps Encapsulation: ENET2
  Input packets : 212590
  Output packets: 71
  Protocol inet, MTU: 1500
  Flags: Is-Primary
  Addresses, Flags: Is-Default Is-Preferred Is-Primary
    Destination: 192.168.3/24, Local: 192.168.3.30,
    Broadcast: 192.168.3.255

```

show interfaces statistics (ACX Series routers)

```

user@host> show interfaces statistics ge-0/1/7
Physical interface: ge-0/1/7, Enabled, Physical link is Down
  Interface index: 151, SNMP ifIndex: 524
  Link-level type: Ethernet, Media type: Copper, MTU: 1514, Link-mode: Full-duplex, Speed:
  1000mbps, BPDU Error: None, MAC-REWRITE Error: None, Loopback: Disabled,
  Source filtering: Disabled, Flow control: Enabled, Auto-negotiation: Enabled, Remote fault:
  Online
  Device flags   : Present Running Down
  Interface flags: Hardware-Down SNMP-Traps Internal: 0x0
  Link flags     : None
  CoS queues    : 8 supported, 8 maximum usable queues
  Current address: 00:00:5E:00:53:a3, Hardware address: 00:00:5E:00:53:a3
  Last flapped  : 2012-05-11 04:25:28 PDT (2d 20:23 ago)
  Statistics last cleared: 2012-05-13 23:07:23 PDT (01:41:25 ago)
  Input rate    : 0 bps (0 pps)
  Output rate   : 0 bps (0 pps)
  Input errors: 0, Output errors: 0
  Active alarms : LINK
  Active defects: LINK
  Interface transmit statistics: Disabled

```

Release Information

Command introduced before Junos OS Release 7.4.

Command introduced in Junos OS Release 12.2 for ACX Series Routers.

satellite-device option introduced in Junos OS Release 14.2R3.

RELATED DOCUMENTATION

[clear interfaces statistics](#)

show interfaces terse satellite-device

IN THIS SECTION

- [Syntax | 757](#)
- [Description | 757](#)
- [Options | 757](#)
- [Required Privilege Level | 758](#)
- [Output Fields | 758](#)
- [Sample Output | 758](#)
- [Sample Output | 759](#)
- [Release Information | 761](#)

Syntax

```
show interfaces terse satellite-device (device-alias | all)
```

Description

Display the satellite device extended ports in a Junos Fusion.

Options

device-alias
device-alias Display extended port information for the satellite device using the specified device alias only.

all Display information for all extended ports and aggregated Ethernet interfaces with extended ports as members configured on all of the satellite devices.

Required Privilege Level

view

Output Fields

[Table 40 on page 758](#) lists the output fields for the `show interfaces terse satellite-device` command. Output fields are listed in the approximate order in which they appear.

Table 40: show interfaces terse satellite-device Output Fields

Field Name	Field Description
Interface	Interface name.
Admin	Whether the interface is turned on (up) or off (down).
Link	Link state: up or down .
Proto	Protocol family configured on the logical interface.
Local	Local IP address of the logical interface.
Remote	Remote IP address of the logical interface.

Sample Output

show interfaces terse satellite-device device-alias

```

user@aggregation-device> show interfaces terse satellite-device TOR1
Interface          Admin Link Proto  Local          Remote
sd-101/0/0         up   up
sd-101/0/0.32770   up   up   bridge

```

```

xe-101/0/14          up   up
xe-101/0/15          up   up
xe-101/0/16          up   up
xe-101/0/17          up   up
xe-101/0/24          up   up
xe-101/0/25          up   up
xe-101/0/31          up   up
xe-101/0/31.0        up   up   bridge
xe-101/0/32          up   down
xe-101/0/32.0        up   down   bridge
xe-101/0/33          up   down
xe-101/0/33.0        up   down   bridge
ge-101/0/36          up   down
et-101/0/48          up   down
xe-101/0/50:0        up   up
xe-101/0/50:0.0      up   up   bridge
xe-101/0/50:1        up   up
xe-101/0/50:2        up   up
xe-101/0/50:2.0      up   up   bridge
xe-101/0/50:3        up   up

```

Sample Output

show interfaces terse satellite-device all

```

user@aggregation-device> show interfaces terse satellite-device all
Interface          Admin Link Proto   Local          Remote
ae0                 up   up
ae0.0               up   up   bridge
ae1                 up   up
ae1.0               up   up   bridge
ae2                 up   up
ae2.0               up   up   bridge
ae3                 up   up
ae3.0               up   up   bridge
ae4                 up   up
ae4.0               up   up   bridge
ae5                 up   up
ae5.0               up   up   bridge
ae6                 up   up
ae6.0               up   up   bridge

```

ae7	up	up	
ae7.0	up	up	bridge
ae8	up	up	
ae8.0	up	up	bridge
ae9	up	up	
ae9.0	up	up	bridge
ae10	up	down	
ae10.0	up	down	bridge
xe-101/0/14	up	up	
xe-101/0/15	up	up	
xe-101/0/16	up	up	
xe-101/0/17	up	up	
xe-101/0/24	up	up	
xe-101/0/25	up	up	
xe-101/0/31	up	up	
xe-101/0/31.0	up	up	bridge
xe-101/0/32	up	down	
xe-101/0/32.0	up	down	bridge
xe-101/0/33	up	down	
xe-101/0/33.0	up	down	bridge
ge-101/0/36	up	down	
et-101/0/48	up	down	
xe-101/0/50:0	up	up	
xe-101/0/50:0.0	up	up	bridge
xe-101/0/50:1	up	up	
xe-101/0/50:2	up	up	
xe-101/0/50:2.0	up	up	bridge
xe-101/0/50:3	up	up	
xe-102/0/10	up	up	
xe-102/0/11	up	up	
xe-102/0/12	up	down	
xe-102/0/13	up	up	
xe-102/0/14	up	up	
xe-102/0/15	up	up	
xe-102/0/16	up	up	
xe-102/0/17	up	up	
xe-102/0/24	up	up	
xe-102/0/25	up	up	
xe-102/0/31	up	up	
xe-102/0/31.0	up	up	bridge
xe-102/0/32	up	up	
xe-102/0/32.0	up	up	bridge
xe-102/0/33	up	up	

```

xe-102/0/45      up    down
ge-102/0/46      up    down
xe-102/0/47      up    down
et-102/0/48      up    down
et-102/0/49      up    down
et-102/0/50      up    down
et-102/0/51      up    down
et-102/0/52      up    down
et-102/0/53      up    down
ge-103/0/0       up    up
ge-103/0/0.0     up    up    aenet    --> ae0.0
ge-103/0/1       up    down
ge-103/0/1.0     up    down    aenet    --> ae1.0
ge-103/0/2       up    up
ge-103/0/2.0     up    up    aenet    --> ae2.0
ge-103/0/3       up    up

```

Release Information

Command introduced in Junos OS Release 14.2R3.

RELATED DOCUMENTATION

[Configuring or Expanding a Junos Fusion Enterprise](#)

show system core-dumps

IN THIS SECTION

- [Syntax | 762](#)
- [Syntax \(SRX Series\) | 762](#)
- [Syntax \(Junos OS Evolved\) | 762](#)
- [Syntax \(EX Series Switches\) | 762](#)
- [Syntax \(TX Matrix Router\) | 763](#)
- [Syntax \(TX Matrix Plus Router\) | 763](#)

- [Syntax \(QFX Series and OCX Series\) | 763](#)
- [Description | 763](#)
- [Options | 764](#)
- [Required Privilege Level | 766](#)
- [Output Fields | 766](#)
- [Sample Output | 768](#)
- [Release Information | 780](#)

Syntax

```
show system core-dumps
<re0>
<re1>
<routing-engine>
<satellite [fpc-slot-id |device-alias alias-name]>
```

Syntax (SRX Series)

```
show system core-dumps
```

Syntax (Junos OS Evolved)

```
show system core-dumps
```

Syntax (EX Series Switches)

```
show system core-dumps
<all-members>
<local>
<member member-id>
```

Syntax (TX Matrix Router)

```
show system core-dumps
<all-chassis | all-lcc | lcc number | scc>
```

Syntax (TX Matrix Plus Router)

```
show system core-dumps
<all-chassis | all-lcc | lcc number | sfc number>
```

Syntax (QFX Series and OCX Series)

```
show system core-dumps
<component (UUID | serial number | all)>
<display-period (hours | minutes | seconds)>
<display-order>
<kernel-crashinfo component (UUID | serial number)>
<repository (core | log)>
```

Description

Show core files on all routers or switches running Junos OS. You can use the `show system core-dumps` command to show a list of system core files created when the router or switch has failed. This command can be useful for diagnostic purposes. Each list item includes the file permissions, number of links, owner, group, size, modification date, and path and filename. If dual Routing Engines are present, you can view core-dump files for either routing engine or both routing engines together. On a QFabric system, you can view core-dump files on individual QFabric system devices as well as on the entire QFabric system.

For Junos OS, all cores files are stored at `/var/core/re`. For Junos OS Evolved, a core file created during early bootup is stored in `/var/core/re`. But a core file created later in the bootup, for example, after the Routing Engine slot number can be determined, is stored in `/var/core/re0` or `/var/core/re1`. The command `show system core-dumps` continues to show all cores generated.

The core files are placed in the `/var/tmp/corefiles` on the SPC3 cards. Each PIC of the SPC3 card has five core files quota on the RE. When no more than five core files from one SPC3 PIC are on the RE, and the RE hard drive has more than 5 GB capacity, core file from the specific PIC is saved at the time it arrives. When there are already five core files from one SPC3 PIC on the RE, the newly arrived core file

from the specific PIC replaces the last core file created by that PIC on the RE. When 5 GB capacity limit is reached, core file is not copied onto the RE. Only a zero sized shadow file with the same file name suffixed by “.shadow” is created. The core file is reached on the specific SPC3 PIC.

On vSRX, the srxpfe process might stop if you perform a reboot or an upgrade. You might observe core files when you execute the show system core-dump command.

Options

none Display a list of all existing core-dump files.

NOTE: If dual Routing Engines are present, then only the core-dump files for the active Routing Engine are listed. For Junos OS Evolved, core-dump files for all Routing Engines are listed.

all-chassis (TX Matrix and TX Matrix Plus routers only) (Optional) On a routing matrix based on a TX Matrix router, display system core files for the TX Matrix router switch-card chassis [SCC] and all the T640 routers [LCCs] connected to the TX Matrix router.

On a routing matrix based on a TX Matrix Plus router, display system core files for the TX Matrix Plus router (switch-fabric chassis [SFC]) and all the T1600 routers [LCCs] connected to the TX Matrix Plus router.

<all-lcc | lcc *number*> (TX Matrix and TX Matrix Plus routers only) (Optional) On a routing matrix based on the TX Matrix router, display core dump files for all T640 routers (line-card chassis [LCCs]) or a specific T640 router [LCC] connected to the TX Matrix router.

On a routing matrix based on the TX Matrix Plus router, display logging information for all T1600 routers (line-card chassis [LCCs]) or a specific T1600 router (LCC) connected to the TX Matrix Plus router. When using the *lcc number* option, replace *number* with a value from 0 through 3.

NOTE: The *all-chassis* option displays system core files for the SCC or SFC and the LCCs connected to the SCC or SFC in the routing matrix while the *all-lcc* option only displays system core files for the LCCs in the routing matrix.

all-members	(EX4200 switches) (Optional) Display system core files on all members of the Virtual Chassis configuration.
component (<i>UUID</i> <i>serial number</i> <i>all</i>)	(QFabric systems only) (Optional) Display a list of core-dump files located on individual QFabric system device or on the entire QFabric system.
display-order (<i>timestamp-sort</i> <i>alphanumeric-sort</i>)	(QFabric systems only) (Optional) Display list of debug artifacts generated within the specified period—for example, within the last hour, within the last 20 minutes, or within the last 32 seconds—or according to their filename.
display-period (<i>hours</i> <i>minutes</i> <i>seconds</i>)	(QFabric systems only) (Optional) Display core-dump files generated within the specified period—for example, within the last hour, within the last 20 minutes, or within the last 32 seconds.
kernel-crashinfo component (<i>UUID</i> <i>serial number</i>)	(QFabric systems only) (Optional) Display kernel crash information from the EEPROM on a QFabric system device.
local	(EX4200 switches only) (Optional) Display system core files on the local Virtual Chassis member.
member <i>member-id</i>	(EX4200 switches only) (Optional) Display system core files on the specified member of the Virtual Chassis configuration. Replace <i>member-id</i> with a value from 0 through 9.
node <i>node-name</i>	(Optional) (Junos OS Evolved only) Display system core files generated on the specified node.
re0	(Dual Routing Engines only) Display the core-dump files on re0.
re1	(Dual Routing Engines only) Display the coredump files on re1.
repository (<i>core</i> <i>log</i>)	(QFabric systems only) (Optional) Specify either the core or log repository in which to view core-dump files.
routing-engine (<i>backup</i> <i>both</i> <i>local</i> <i>master</i> <i>other</i>)	(Dual routing engines only) Display a list of core-dump files for either the backup, local, primary, or other routing engine or both routing engines.
satellite [<i>fpc-slot-id</i> <i>device-alias</i> <i>alias-name</i>]	(Junos Fusion only)(Optional) Display system core files for the specified satellite device in a Junos Fusion, or for all satellite devices in the Junos Fusion if no satellite devices are specified.
scc	(TX Matrix routers only) (Optional) Display system core files on the TX Matrix router (or switch-card chassis).

sfc (TX Matrix Plus routers only) (Optional) Display system core files on the TX Matrix Plus router (or switch-fabric chassis).

Required Privilege Level

view

Output Fields

[Table 41 on page 766](#) describes the output fields for the `show system core-dumps` command. Output fields are listed in the approximate order in which they appear.

Table 41: show system core-dumps Output Fields

Field Name	Field Description
<i>Permissions</i>	Read/write permissions for the file named.
<i>Links</i>	Number of links to the file.
<i>Owner</i>	Name of the file owner.
<i>Group</i>	Name of the group with file access.
<i>File size</i>	File size in bytes.
<i>Modified</i>	Last file modification date and time.
<i>Path/filename</i>	File path where the file resides and the filename. (MX Series routers only) When you display the core files for an MX Series Virtual Chassis, the <code>show system core-dumps</code> command does not display information about files pertaining to the relayd process.

Table 41: show system core-dumps Output Fields (Continued)

Field Name	Field Description
Repository scope:	Repository where core-dump files and log files are stored. The core-dump files are located in the core repository, and the log files are located in the log repository. The default Repository scope is shared since both the core and log repositories are shared by all of the QFabric system devices.
Repository head:	Path to the top-level repository location.
Repository name:	Name of the repository: core or log.
List of nodes for core repository:	List of core-dump files associated with a particular QFabric system device located in the core repository.
Node Group	Name of the QFabric system device.
Node Identifier	UUID or serial number of the QFabric system device.
Num	Number of core-dump and log files.
Model	Model number of the QFabric system device.
Usage	Usage of the repository in megabytes.
Total usage of core repository:	Total usage of core-dump files associated with a particular QFabric system device located in the core repository. Usage is specified in megabytes and as a percentage.
Total usage of log repository:	Total usage of log files associated with a particular QFabric system device located in the log repository. Usage is specified in megabytes and as a percentage.
List of nodes for core repository:	List of core-dump files associated with a particular QFabric system device located in the core repository.

Table 41: show system core-dumps Output Fields (Continued)

Field Name	Field Description
List of nodes for log repository:	List of log files associated with a particular QFabric system device located in the log repository.
Filename	Name of the core-dump file.
Date	Last core-dump file modification date and time.
Size	Size of the core-dump file.
Core filename	Filename of the core-dump file.
Process name	Name of the process that is generating a core-dump file or log file.
Release	Junos OS release.
Build server	Junos OS build server.
Build date	Junos OS build date.
Stack trace	Stack trace of the core-dump file.

Sample Output

show system core-dumps

This example shows the command output if core files exist.

```
user@host> show system core-dumps
-rw----- 1 root wheel 268369920 Jun 18 17:59 /var/crash/vmcore.0
```

```
-rw-rw---- 1 root field 3371008 Jun 18 17:53 /var/tmp/rpd.core.0
-rw-r--r-- 1 root wheel 27775914 Jun 18 17:59 /var/crash/kernel.0
```

show system core-dumps

This example shows the command output if core files do not exist.

```
user@host> show system core-dumps
/var/crash/*core*: No such file or directory
/var/tmp/*core*: No such file or directory
/var/tmp/pics/*core*: No such file or directory
/var/crash/kernel.*: No such file or directory
```

show system core-dumps routing-engine both

This example shows the command output if dual Routing Engines are present.

```
user@host> show system core-dumps routing-engine both
re0:
-----
/var/crash/*core*: No such file or directory
/var/tmp/pics/*core*: No such file or directory
/var/crash/kernel.*: No such file or directory

/var/tmp/cores:
total blocks: 496776
-rw-rw---- 1 root field 11910589 Nov 8 13:20 chassisd.core.0.201311081320
...

-rw-rw---- 1 root field 11737227 Oct 28 14:21 rpd.core-tarball.4.tgz.201310281421.3458162
total files: 10

re1:
-----
/var/crash/*core*: No such file or directory
/var/tmp/pics/*core*: No such file or directory
/var/crash/kernel.*: No such file or directory

/var/tmp/cores:
total blocks: 3178420
```

```

-rw-rw---- 1 root field 19039721 Nov 8 14:29 chassisd.core.0.201311081429.3485600.gz
-rw-rw---- 1 root field 19039793 Nov 8 14:37 chassisd.core.1.201311081437.3485599.gz
..

-rw-rw---- 1 root field 11710113 Oct 17 15:26 rpd.core-tarball.1.tgz.201310171526.3430028

```

show system core-dumps (SRX Series)

```
user@host> show system core-dumps
```

```

/var/crash/*core*: No such file or directory
-rw-r--r-- 1 nobody wheel 1439949 Apr 24 10:38 /var/tmp/FPC0_PIC0.localhost.J-
UKERN.23421.1556127502.core.tgz
-rw-r--r-- 1 nobody wheel 1435531 Apr 24 10:44 /var/tmp/FPC0_PIC0.localhost.J-
UKERN.24702.1556127821.core.tgz
-rw-r--r-- 1 nobody wheel 288761042 Apr 24 10:32 /var/tmp/
FPC0_PIC0.localhost.flowd_spc3.elf.31620.1556126342.core.tgz
-rw-r--r-- 1 nobody wheel 35082 Apr 24 10:47 /var/tmp/
FPC0_PIC0.localhost.tnp_hello.20972.1556128038.core.tgz
-rw-r--r-- 1 nobody wheel 35367 Apr 24 10:49 /var/tmp/
FPC0_PIC0.localhost.tnp_hello.27233.1556128140.core.tgz
-rw-r--r-- 1 nobody wheel 35372 Apr 24 11:32 /var/tmp/
FPC0_PIC1.localhost.tnp_hello.22289.1556130737.core.tgz
-rw-r--r-- 1 nobody wheel 35357 Apr 24 10:51 /var/tmp/
FPC0_PIC1.localhost.tnp_hello.22492.1556128268.core.tgz
-rw-r--r-- 1 nobody wheel 34812 Apr 24 11:33 /var/tmp/
FPC0_PIC1.localhost.tnp_hello.24235.1556130795.core.tgz
-rw-r--r-- 1 nobody wheel 35383 Apr 24 11:18 /var/tmp/
FPC0_PIC1.localhost.tnp_hello.27070.1556129899.core.tgz
-rw-r--r-- 1 nobody wheel 34675 Apr 24 11:18 /var/tmp/
FPC0_PIC1.localhost.tnp_hello.31621.1556129928.core.tgz
/var/tmp/pics/*core*: No such file or directory
/var/crash/kernel.*: No such file or directory
/var/jails/rest-api/tmp/*core*: No such file or directory
/tftpboot/corefiles/*core*: No such file or directory
total files: 10

```

show system core-dumps (TX Matrix Plus Router)

```

user@host> show system core-dumps
sfc0-re0:
-----
/var/crash/kernel.*: No such file or directory
/tftpboot/corefiles/*core*: No such file or directory

/var/crash/cores:
total 8

/var/tmp/cores:
total 1627592
-rw-r--r-- 1 root field 535346090 May 15 07:36 rpd.core-tarball.0.090515.0736.tgz
-rw-r--r-- 1 root field 105632057 May 15 07:37 rpd.core-tarball.1.090515.0737.tgz
-rw-r--r-- 1 root field 101981681 May 15 07:38 rpd.core-tarball.2.090515.0738.tgz
-rw-r--r-- 1 root field 85854573 May 15 07:40 rpd.core-tarball.3.090515.0740.tgz
-rw-r--r-- 1 root field 4157845 May 15 08:18 rpd.core-tarball.4.090515.0818.tgz

lcc0-re0:
-----
/var/crash/kernel.*: No such file or directory
/tftpboot/corefiles/*core*: No such file or directory

/var/crash/cores:
total 8

/var/tmp/cores:
total 12

lcc1-re0:
-----
/var/crash/kernel.*: No such file or directory
/tftpboot/corefiles/*core*: No such file or directory

/var/crash/cores:
total 8

/var/tmp/cores:
total 10024
-rw-r--r-- 1 root field 1875794 Apr 22 15:47 chassisd.core-tarball.0.090422.1547.tgz
-rw-r--r-- 1 root field 1894183 Apr 22 19:02 chassisd.core-tarball.0.090422.1902.tgz

```

```

-rw-r--r-- 1 root field 1290240 Apr 26 16:01 ksyncd_1558.core.0.090426.1601

lcc2-re0:
-----
/var/crash/kernel.*: No such file or directory
/tftpboot/corefiles/*core*: No such file or directory

/var/crash/cores:
total 21124008
-rw-r--r-- 1 root wheel 1022376528 May 2 06:43 core-LCC2-EGFPC7.core.0.090502.0643
-rw-r--r-- 1 root wheel 1022376528 May 2 08:13 core-LCC2-EGFPC7.core.0.090502.0813
-rw-r--r-- 1 root wheel 1022376544 May 5 06:15 core-LCC2-EGFPC7.core.0.090505.0615
-rw-r--r-- 1 root wheel 1022376544 May 6 10:59 core-LCC2-EGFPC7.core.0.090506.1059
-rw-r--r-- 1 root wheel 1022376528 May 2 06:58 core-LCC2-EGFPC7.core.1.090502.0658
-rw-r--r-- 1 root wheel 754271232 May 5 06:33 core-LCC2-EGFPC7.core.1.090505.0633
-rw-r--r-- 1 root wheel 264897536 May 6 11:12 core-LCC2-EGFPC7.core.1.090506.1112
-rw-r--r-- 1 root wheel 1022376528 May 2 07:22 core-LCC2-EGFPC7.core.2.090502.0722
-rw-r--r-- 1 root wheel 163633152 May 5 06:52 core-LCC2-EGFPC7.core.2.090505.0652
-rw-r--r-- 1 root wheel 171312128 May 6 12:13 core-LCC2-EGFPC7.core.2.090506.1213
-rw-r--r-- 1 root wheel 1022376528 May 2 07:39 core-LCC2-EGFPC7.core.3.090502.0739
-rw-r--r-- 1 root wheel 1022376528 May 2 07:55 core-LCC2-EGFPC7.core.4.090502.0755
-rw-r--r-- 1 root wheel 427277312 May 7 04:47 core-LCC2-STFPC4.core.0.090507.0447
-rw-r--r-- 1 root wheel 419609600 May 7 04:47 core-LCC2-STFPC5.core.0.090507.0447
-rw-r--r-- 1 root wheel 432356352 May 7 04:47 core-LCC2-STFPC6.core.0.090507.0447

/var/tmp/cores:
total 2568
-rw-r--r-- 1 root field 1290240 May 14 14:26 ksyncd_1540.core.0.090514.1426
...

```

show system core-dumps (QFX3500 Switch)

```

user@switch> show system core-dumps
/var/crash/*core*: No such file or directory
-rw-rw---- 1 root field 1545143 Jun 4 2012 /var/tmp/pafxpc.core.0.gz
-rw-rw---- 1 root field 1545146 Jun 4 2012 /var/tmp/pafxpc.core.1.gz
-rw-rw---- 1 root field 1545141 Jun 4 2012 /var/tmp/pafxpc.core.2.gz
-rw-rw---- 1 root field 1545146 Jun 4 2012 /var/tmp/pafxpc.core.3.gz
-rw-rw---- 1 root field 1545142 Jun 5 2012 /var/tmp/pafxpc.core.4.gz
/var/tmp/pics/*core*: No such file or directory
/var/crash/kernel.*: No such file or directory

```

```
/tftpboot/corefiles/*core*: No such file or directory
total 5
```

show system core-dumps (QFabric Systems)

```
user@switch> show system core-dumps
Repository scope: shared
Repository head: /pbdata/export
List of nodes for core repository: /pbdata/export/rdumps/
```

Node Group	Node Identifier	Num	Model	Usage
DG-0	BCF7208D-E44F-E011-802F-4171BAAC781D	0	qfx3100	0M
FM-0	73747cd8-0710-11e1-b6a4-00e081c5297e	0	fx-jvre	0M
DRE-0	77116f18-0710-11e1-a2a0-00e081c5297e	0	fx-jvre	0M
NW-NG-0	BBAK0394	0	qfx3500	0M
NW-NG-0	cd78871a-0710-11e1-878e-00e081c5297e	0	fx-jvre	0M
NW-NG-0	d0afda1e-0710-11e1-a1d0-00e081c5297e	0	fx-jvre	0M
FC-0	d31ab7a6-0710-11e1-ad1b-00e081c5297e	0	fx-jvre	0M
FC-1	d4d0f254-0710-11e1-90c3-00e081c5297e	0	fx-jvre	0M
IC-WS001	WS001	0	-	-
IC-WS001	WS001/YW3803	0	qfxc08-3008	0M
IC-WS001	WS001/YN5999	0	qfxc08-3008	0M
node-device1	BBAK0372	0	qfx3500	0M
node-device1	EE3093	0	qfx3500	0M

Total usage of core repository: 0M of 70000M (0.0%)

```
List of nodes for log repository: /pbdata/export/rlogs/
```

Node Group	Node Identifier	Num	Model	Usage
DG-0	BCF7208D-E44F-E011-802F-4171BAAC781D	0	qfx3100	0M
FM-0	73747cd8-0710-11e1-b6a4-00e081c5297e	1	fx-jvre	0M
DRE-0	77116f18-0710-11e1-a2a0-00e081c5297e	1	fx-jvre	0M
NW-NG-0	BBAK0394	1	qfx3500	0M
NW-NG-0	cd78871a-0710-11e1-878e-00e081c5297e	1	fx-jvre	0M
NW-NG-0	d0afda1e-0710-11e1-a1d0-00e081c5297e	3	fx-jvre	0M
FC-0	d31ab7a6-0710-11e1-ad1b-00e081c5297e	1	fx-jvre	0M
FC-1	d4d0f254-0710-11e1-90c3-00e081c5297e	1	fx-jvre	0M
IC-WS001	WS001	0	-	-
IC-WS001	WS001/YN5999	1	qfxc08-3008	0M
IC-WS001	WS001/YW3803	1	qfxc08-3008	0M
node-device1	BBAK0372	1	qfx3500	0M

```
node-device1    EE3093                1    qfx3500    0M
Total usage of log repository:0M of 70000M (0.0%)
```

show system core-dumps component serial number display-order alphanumeric-sort repository core (QFabric Systems)

```
user@switch> show system core-dumps component BBAK8891 display-order alphanumeric-sort repository core
```

Repository scope: shared

Repository head: /pbdata/export

Repository name: core

List of core dumps for component BBAK8891

Repository location: /pbdata/export/rdumps/BBAK8891

Filename	Date	Size
eswd.core.0.1361.11172011214257.gz	Nov 17 21:43:10 2011	4779553
eswd.core.1.80267.11172011214514.gz	Nov 17 21:45:19 2011	3541648
eswd.core.2.80682.11172011214535.gz	Nov 17 21:45:43 2011	2156683
vccpd.core.0.1195.11182011151131.gz	Nov 18 15:11:35 2011	375617

Number of core dumps in repository:4

show system core-dumps display-period (QFabric Systems)

```
user@switch> show system core-dumps display-period 24h
```

```
show system core-dumps display-period 24h
```

Repository scope: shared

Repository head: /pbdata/export

List of core dumps at repository: /pbdata/export/rdumps

Delta timespec: Last 24h

Component: BBAK8273

Filename	Size	Date
vccpd.core.0.1195.11182011151131.gz	Nov 18 15:11:35 2011	375794

Component: cedb7b0e-0025-11e1-9a5f-00e081c52990

Filename	Size	Date
vccpd.core.0.1461.11182011151131.gz	Nov 18 15:11:31 2011	120951

Component: ee19c4f8-0025-11e1-aef6-00e081c52990

Filename	Size	Date
vccpd.core.0.1461.11182011151131.gz	Nov 18 15:11:31 2011	120951

vccpd.core.0.1462.11182011151131.gz	Nov 18 15:11:31 2011	109420
Component: BBAK8281		
Filename	Size	Date
vccpd.core.0.1196.11182011151131.gz	Nov 18 15:11:36 2011	375373
Component: BBAK8891		
Filename	Size	Date
vccpd.core.0.1195.11182011151131.gz	Nov 18 15:11:35 2011	375617
Component: BBAK8276		
Filename	Size	Date
vccpd.core.0.1196.11182011151131.gz	Nov 18 15:11:35 2011	375350
Component: BBAK8868		
Filename	Size	Date
vccpd.core.0.1196.11182011151130.gz	Nov 18 15:11:34 2011	376211
Component: BBAK8835		
Filename	Size	Date
vccpd.core.0.1195.11182011151130.gz	Nov 18 15:11:35 2011	375700
Component: BBAK8283		
Filename	Size	Date
vccpd.core.0.1195.11182011151131.gz	Nov 18 15:11:36 2011	368298
Component: YW3781/YW3781		
Filename	Size	Date
vccpd.core.0.1220.11182011151131.gz	Nov 18 15:11:38 2011	380002
Component: 09726be2-0026-11e1-82d9-00e081c52990		
Filename	Size	Date
vccpd.core.0.1461.11182011151130.gz	Nov 18 15:11:31 2011	119965
Component: BBAK8309		
Filename	Size	Date
vccpd.core.0.1196.11182011151131.gz	Nov 18 15:11:36 2011	378930
Component: 303d476a-0026-11e1-abf4-00e081c52990		
Filename	Size	Date
vccpd.core.0.1460.11182011151131.gz	Nov 18 15:11:31 2011	118385
Component: YW3798/YW3798		

Filename	Size	Date
vccpd.core.0.1219.11182011151131.gz	Nov 18 15:11:36 2011	380455
List of log dumps at repository: /pbdata/export/rlogs		
Delta timespec: Last 24h		
Component: BBAK8273		
Filename	Size	Date
vccpd.tarball.0.1195.11182011151138.tgz	Nov 18 15:11:39 2011	20415
Component: cedb7b0e-0025-11e1-9a5f-00e081c52990		
Filename	Size	Date
vccpd.tarball.0.1461.11182011151131.tgz	Nov 18 15:11:33 2011	19651
Component: ee19c4f8-0025-11e1-aef6-00e081c52990		
Filename	Size	Date
vccpd.tarball.0.1462.11182011151133.tgz	Nov 18 15:11:36 2011	24650
Component: BBAK8281		
Filename	Size	Date
vccpd.tarball.0.1196.11182011151137.tgz	Nov 18 15:11:41 2011	19445
Component: BBAK8891		
Filename	Size	Date
vccpd.tarball.0.1195.11182011151138.tgz	Nov 18 15:11:41 2011	21916
Component: BBAK8276		
Filename	Size	Date
vccpd.tarball.0.1196.11182011151137.tgz	Nov 18 15:11:39 2011	20461
Component: BBAK8868		
Filename	Size	Date
vccpd.tarball.0.1196.11182011151137.tgz	Nov 18 15:11:41 2011	21924
Component: BBAK8835		
Filename	Size	Date
vccpd.tarball.0.1195.11182011151137.tgz	Nov 18 15:11:39 2011	19424
Component: BBAK8283		
Filename	Size	Date
vccpd.tarball.0.1195.11182011151138.tgz	Nov 18 15:11:42 2011	31186
Component: YW3781/YW3781		
Filename	Size	Date

vccpd.tarball.0.1220.11182011151141.tgz	Nov 18 15:11:45 2011	27565
Component: 09726be2-0026-11e1-82d9-00e081c52990		
Filename	Size	Date
vccpd.tarball.0.1461.11182011151130.tgz	Nov 18 15:11:34 2011	19613
Component: BBAK8309		
Filename	Size	Date
vccpd.tarball.0.1196.11182011151138.tgz	Nov 18 15:11:46 2011	50362
Component: 303d476a-0026-11e1-abf4-00e081c52990		
Filename	Size	Date
vccpd.tarball.0.1460.11182011151133.tgz	Nov 18 15:11:33 2011	19360
Component: YW3798/YW3798		
Filename	Size	Date
vccpd.tarball.0.1219.11182011151140.tgz	Nov 18 15:11:49 2011	24473

show system core-dumps kernel-crashinfo component serial number (QFabric Systems)

```

user@switch> show system core-dumps kernel-crashinfo component A0001/YA0197
Node: A0001/YA0197

Information about previous kernel crash:

-- Kernel panic data --

Panic string: kdb_sysctl_panic
System uptime: 3 day 20 hr 59 min 40 sec Kernel crash time: 2011-11-15 Wed 15:25:17 Kernel build
linkstamp: JUNOS 11.3I #0: 2011-11-10 20:42:27 UTC

-- Stacktrace of panicing context --
Processor 1 (crash monarch):
savectx+0x0 (c9552800,80214efc,802a7fbc,c88ad05c) ra 801b93a8 sz 0
kdm_kcore_save_crashinfo+0x254 (c9552800,0,802a7fbc,c88ad05c) ra 801b9f44 sz 784
kdm_kcore_kern_panic_event_handler+0x4b0 (c9552800,0,802a7fbc,c88ad05c) ra 8022a9b8 sz 88
panic+0x1d0 (c9552800,0,4,77fed534) ra 802540c0 sz 56
kdb_sysctl_panic+0x70 (c9552800,0,4,77fed534) ra 80237e58 sz 40 sysctl_root+0x12c
(c9552800,0,4,e8bc5cf8) ra 80238e50 sz 48
userland_sysctl+0x164 (c9552800,0,4,e8bc5cf8) ra 8023956c sz 104

```

```
__sysctl+0xe4 (c9552800,0,4,e8bc5cf8) ra 806d62e8 sz 160
trap+0xe1c (c9552800,0,4,e8bc5cf8) ra 80896e68 sz 128
MipsUserGenException+0x1a4 (c9552800,0,4,405cd12c) ra 0 sz 0
pid 82340, process: sysctl
```

Processor 0:

```
restoreintr+0x14 (1,81bca820,3,0) ra 806cdc3c sz 0
spinlock_exit+0x30 (1,81bca820,3,0) ra 8025d354 sz 24
sleepq_release+0x64 (1,81bca820,3,0) ra 8025e670 sz 24
sleepq_timeout+0x224 (1,81bca820,3,0) ra 80240294 sz 48
softclock+0x434 (1,81bca820,3,0) ra 802067f8 sz 80
ithread_loop+0x244 (1,81bca820,3,0) ra 80200e28 sz 64 fork_exit+0xc0 (1,81bca820,3,0) ra
80897c28 sz 48
MipsNMIException+0x34 (1,81bca820,3,0) ra 0 sz 0
pid 82340, process: sysctl
```

Processor 2:

```
cpu_idle+0x20 (80960000,51bbc,2031df,81bca1b8) ra 80204948 sz 24 idle_proc+0x130
(80960000,51bbc,2031df,81bca1b8) ra 80200e28 sz 56 fork_exit+0xc0
(80960000,51bbc,2031df,81bca1b8) ra 80897c28 sz 48
MipsNMIException+0x34 (80960000,51bbc,2031df,81bca1b8) ra 0 sz 0
pid 82340, process: sysctl
```

Processor 3:

```
cpu_idle+0x20 (80960000,51bbc,2038df,81bca300) ra 80204948 sz 24 idle_proc+0x130
(80960000,51bbc,2038df,81bca300) ra 80200e28 sz 56 fork_exit+0xc0
(80960000,51bbc,2038df,81bca300) ra 80897c28 sz 48
MipsNMIException+0x34 (80960000,51bbc,2038df,81bca300) ra 0 sz 0
pid 82340, process: sysctl
```

Processor 4:

```
cpu_idle+0x20 (80960000,51bbc,2037df,81bca448) ra 80204948 sz 24 idle_proc+0x130
(80960000,51bbc,2037df,81bca448) ra 80200e28 sz 56 fork_exit+0xc0
(80960000,51bbc,2037df,81bca448) ra 80897c28 sz 48
MipsNMIException+0x34 (80960000,51bbc,2037df,81bca448) ra 0 sz 0
pid 82340, process: sysctl
```

Processor 5:

```
restoreintr+0x14 (1,51bbc,203edf,81bca590) ra 806cdc3c sz 0
spinlock_exit+0x30 (1,51bbc,203edf,81bca590) ra 80204a34 sz 24 idle_proc+0x21c
(1,51bbc,203edf,81bca590) ra 80200e28 sz 56 fork_exit+0xc0 (1,51bbc,203edf,81bca590) ra 80897c28
sz 48
MipsNMIException+0x34 (1,51bbc,203edf,81bca590) ra 0 sz 0
```

```
pid 82340, process: sysctl
```

```
Processor 6:
```

```
cpu_idle+0x20 (80960000,51bbc,205cdf,81bca6d8) ra 80204948 sz 24 idle_proc+0x130
```

```
(80960000,51bbc,205cdf,81bca6d8) ra 80200e28 sz 56 fork_exit+0xc0
```

```
(80960000,51bbc,205cdf,81bca6d8) ra 80897c28 sz 48
```

```
MipsNMIException+0x34 (80960000,51bbc,205cdf,81bca6d8) ra 0 sz 0
```

```
pid 82340, process: sysctl
```

```
Processor 7:
```

```
lockmgr+0x5ac (c97e8484,c8dd9800,0,c8dd9800) ra 8c11c81c sz 48
```

```
sal_sem_take+0x134 (c97e8484,c8dd9800,0,c8dd9800) ra 8c351108 sz 56 _bcm_esw_linkscan_thread
```

```
+0x45c (c97e8484,c8dd9800,0,c8dd9800) ra 8c11cdb4 sz 104
```

```
sal_thread_start_wrap+0x74 (c97e8484,c8dd9800,0,c8dd9800) ra 80200e28 sz 32 fork_exit+0xc0
```

```
(c97e8484,c8dd9800,0,c8dd9800) ra 80897c28 sz 48
```

```
MipsNMIException+0x34 (c97e8484,c8dd9800,0,c8dd9800) ra 0 sz 0
```

```
pid 82340, process: sysctl
```

```
-- End of stacktrace --
```

show system core-dumps repository core (QFabric Systems)

```
user@switch> show system core-dumps repository core
```

```
Repository scope: shared
```

```
Repository head: /pbdata/export
```

```
Repository name: core
```

```
List of nodes for core repository: /pbdata/export/rdumps/
```

Node Group	Node Identifier	Num	Model	Usage
DG-0	BCF7208D-E44F-E011-802F-4171BAAC781D	0	qfx3100	0M
FM-0	73747cd8-0710-11e1-b6a4-00e081c5297e	0	fx-jvre	0M
DRE-0	77116f18-0710-11e1-a2a0-00e081c5297e	0	fx-jvre	0M
NW-NG-0	BBAK0394	0	qfx3500	0M
NW-NG-0	cd78871a-0710-11e1-878e-00e081c5297e	0	fx-jvre	0M
NW-NG-0	d0afda1e-0710-11e1-a1d0-00e081c5297e	0	fx-jvre	0M
FC-0	d31ab7a6-0710-11e1-ad1b-00e081c5297e	0	fx-jvre	0M
FC-1	d4d0f254-0710-11e1-90c3-00e081c5297e	0	fx-jvre	0M
IC-WS001	WS001	0	-	-
IC-WS001	WS001/YW3803	0	qfxc08-3008	0M
IC-WS001	WS001/YN5999	0	qfxc08-3008	0M
node-device1	BBAK0372	0	qfx3500	0M

```
node-device1 EE3093 0 qfx3500 0M
Total usage of core repository:0M of 70000M (0.0%)
```

show system core-dumps repository log (QFabric Systems)

```
user@switch> show system core-dumps repository log
Repository scope: shared
Repository head: /pbdata/export
Repository name: log
List of nodes for log repository: /pbdata/export/rlogs/
Node Group      Node Identifier                               Num Model      Usage
-----
DG-0            BCF7208D-E44F-E011-802F-4171BAAC781D        0 qfx3100      0M
FM-0            73747cd8-0710-11e1-b6a4-00e081c5297e        1 fx-jvre      0M
DRE-0           77116f18-0710-11e1-a2a0-00e081c5297e        1 fx-jvre      0M
NW-NG-0         BBAK0394                                     1 qfx3500      0M
NW-NG-0         cd78871a-0710-11e1-878e-00e081c5297e        1 fx-jvre      0M
NW-NG-0         d0afda1e-0710-11e1-a1d0-00e081c5297e        3 fx-jvre      0M
FC-0            d31ab7a6-0710-11e1-ad1b-00e081c5297e        1 fx-jvre      0M
FC-1            d4d0f254-0710-11e1-90c3-00e081c5297e        1 fx-jvre      0M
IC-WS001        WS001                                         0 -            -
IC-WS001        WS001/YN5999                                 1 qfxc08-3008 0M
IC-WS001        WS001/YW3803                                 1 qfxc08-3008 0M
node-device1    BBAK0372                                     1 qfx3500      0M
node-device1    EE3093                                       1 qfx3500      0M
Total usage of log repository:0M of 70000M (0.0%)
```

Release Information

Command introduced before Junos OS Release 8.5.

sfc option introduced in Junos OS Release 9.6 for the TX Matrix Plus router.

re0, re1, and routing-engine options introduced for dual Routing Engines in Junos OS Release 13.1.

satellite option introduced in Junos OS Release 14.2R3.

core-file-info option is deprecated in Junos OS Release 16.1R3.

Enabling Layer 3 Support in a Junos Fusion Enterprise

IN THIS CHAPTER

- [Understanding Integrated Routing and Bridging \(IRB\) Interfaces in a Junos Fusion Enterprise](#) | 781

Understanding Integrated Routing and Bridging (IRB) Interfaces in a Junos Fusion Enterprise

In most campus networking environments, endpoint devices must have a path to send and receive Layer 3 traffic.

In a typical Junos Fusion Enterprise deployment, the EX9200 switch assumes the responsibilities of an aggregation layer switch and is typically the gateway to layer 3. Integrated routing and bridging (IRB) interfaces are, therefore, configured on the EX9200 switches acting as aggregation devices to move traffic between Layer 2 and Layer 3.

See [Understanding Integrated Routing and Bridging](#) for information on configuring IRB interfaces.

See the [Adding Layer 3 Support to a Junos Fusion Enterprise](#) section of the [Enabling Junos Fusion Enterprise on an Enterprise Campus Network](#) for a sample IRB interface configuration in a Junos Fusion Enterprise.

RELATED DOCUMENTATION

| [Understanding Integrated Routing and Bridging](#)

802.1X in a Junos Fusion Enterprise

IN THIS CHAPTER

- [Understanding 802.1X on a Junos Fusion Enterprise | 782](#)

Understanding 802.1X on a Junos Fusion Enterprise

This topic describes 802.1X in a Junos Fusion Enterprise.

802.1X is an IEEE standard for port-based network access control (PNAC). It provides an authentication mechanism for devices seeking to access a LAN. The 802.1X authentication feature is based upon the IEEE 802.1X standard Port-Based Network Access Control.

The range of 802.1X configuration options are beyond the scope of this document. For additional information on 802.1X, see [802.1X for Switches Overview](#) and the [Access Control User Guide for EX9200 Switches](#).

The following requirements should be understood when configuring 802.1X for a Junos Fusion Enterprise:

- The authentication server cannot connect to the Junos Fusion Enterprise through an extended port.
- 802.1X configuration must match on both aggregation devices in a Junos Fusion Enterprise. 802.1X , therefore, should typically be configured using configuration groups that are applied to both aggregation devices using commit synchronization. See "[Understanding Configuration Synchronization in a Junos Fusion](#)" on page 28 and "[Enabling Configuration Synchronization Between Aggregation Devices in a Junos Fusion](#)" on page 89.
- 802.1X control is handled by either aggregation device on a per-session basis. Either aggregation device can act as the primary device for 802.1X control for any 802.1X session. If traffic flow through one aggregation device is disrupted during an 802.1X session, the 802.1X session may be interrupted and control could be transferred to the other aggregation device.
- A captive portal cannot be configured on an extended port.

See [Enabling 802.1X](#) in the [Enabling Junos Fusion Enterprise on an Enterprise Campus Network](#) document for an example of 802.1X configuration on a Junos Fusion Enterprise.

Junos Fusion Enterprise Half-Duplex Links on Satellite Devices

IN THIS CHAPTER

- [Understanding Half-Duplex Links on Satellite Devices in a Junos Fusion Enterprise | 784](#)
- [link-mode | 785](#)

Understanding Half-Duplex Links on Satellite Devices in a Junos Fusion Enterprise

IN THIS SECTION

- [Half-Duplex Links on Satellite Devices Overview | 784](#)
- [Understanding Configuration of Full-Duplex Link Mode on a Satellite Device and Verification of Half-Duplex Mode | 785](#)

This topic describes half-duplex links on satellite devices in a Junos Fusion Enterprise.

This topic covers:

Half-Duplex Links on Satellite Devices Overview

Half-duplex communication is supported on all built-in network copper ports on EX2300, EX3400, and EX4300 satellite devices in a Junos Fusion Enterprise (JFE). *Half-duplex* is bidirectional communication, but signals can flow in only one direction at a time. *Full-duplex* communication means that both ends of the communication can send and receive signals at the same time.

The built-in network copper ports are configured by default as full-duplex 1-gigabit links with autonegotiation. If the link partner is set to autonegotiate the link, then the link is autonegotiated to full

duplex or half-duplex. If the link is not set to autonegotiation, then the satellite-device link defaults to half-duplex unless the interface is explicitly configured for full duplex.

On EX2300, EX3400, and EX4300 satellite devices, the link mode is handled as follows:

- If the link partner is operating in half-duplex, the satellite device interface goes to half-duplex.
- If the link partner is not capable of autonegotiation, the satellite device interface goes to half duplex.
- If the link partner is capable of autonegotiation and is operating in full duplex, the satellite device interface also works in full duplex.

Understanding Configuration of Full-Duplex Link Mode on a Satellite Device and Verification of Half-Duplex Mode

Like all features in a Junos Fusion Enterprise, link modes are configured and verified from the aggregation devices.

To explicitly configure full duplex:

```
[edit]
user@aggregation-device# set interfaces interface-name link-mode full-duplex
```

To verify a half-duplex setting:

```
user@aggregation-device> show interfaces interface-name extensive
```

RELATED DOCUMENTATION

| [Configuring Gigabit Ethernet Interfaces for EX Series Switches with ELS support](#)

link-mode

IN THIS SECTION

● [Syntax](#) | 786

- Hierarchy Level | 786
- Description | 786
- Options | 786
- Required Privilege Level | 787
- Release Information | 787

Syntax

```
link-mode mode (automatic | full-duplex | half-duplex);
```

Hierarchy Level

```
[edit interfaces interface-name],  
[edit interfaces interface-name ether-options],  
[edit interfaces ge-pim/0/0 switch-options switch-port port-number]
```

Description

Set the device's link connection characteristic.

Options

mode—Link characteristics:

- *automatic*—Link mode is negotiated. This is the default for EX Series switches.
- *full-duplex*—Connection is full duplex.
- *half-duplex*—Connection is half duplex.
- **Default:** Fast Ethernet interfaces can operate in either full-duplex or half-duplex mode. The router's or switch's management Ethernet interface, *fxp0* or *em0*, and the built-in Fast Ethernet interfaces on the FIC (M7i router) autonegotiate whether to operate in full-duplex or half-duplex mode. Unless otherwise noted here, all other interfaces operate only in full-duplex mode.

NOTE: On EX Series switches, if `no-auto-negotiation` is specified in `[edit interfaces interface-name ether-options]`, you can select only `full-duplex` or `half-duplex`. If `auto-negotiation` is specified, you can select any mode.

NOTE:

- Member links of an aggregated Ethernet bundle must not be explicitly configured with a link mode. You must remove any such link-mode configuration before committing the aggregated Ethernet configuration.
- Starting with Junos OS release 16.1R7 and later, the `link-mode` configuration is not supported on 10-Gigabit Ethernet Interfaces.
- Starting in Junos OS release 18.4R1, half-duplex mode is supported on SRX340 and SRX345 devices.

Required Privilege Level

`interface`—To view this statement in the configuration.

`interface-control`—To add this statement to the configuration.

Release Information

Statement introduced before Junos OS Release 7.4.

Statement introduced in Junos OS Release 12.2 for ACX Series Universal Metro Routers.

RELATED DOCUMENTATION

[Configuring the Link Characteristics on Ethernet Interfaces](#)

[Understanding Management Ethernet Interfaces](#)

[Configuring Gigabit Ethernet Interfaces \(CLI Procedure\)](#)

[Configuring Gigabit Ethernet Interfaces for EX Series Switches with ELS support](#)

Junos Fusion Enterprise Network Monitoring and Analyzers

IN THIS CHAPTER

- [Understanding sFlow Technology on a Junos Fusion Enterprise | 788](#)
- [Understanding Port Mirroring Analyzers on a Junos Fusion Enterprise | 790](#)

Understanding sFlow Technology on a Junos Fusion Enterprise

IN THIS SECTION

- [sFlow Technology on a Junos Fusion Enterprise Overview | 788](#)
- [Understanding the sFlow Sampling Mechanism on a Junos Fusion Enterprise | 789](#)
- [Limitations for sFlow on a Junos Fusion Enterprise | 790](#)

This topic describes sFlow technology in a Junos Fusion Enterprise.

This topic covers:

sFlow Technology on a Junos Fusion Enterprise Overview

sFlow technology is a monitoring technology for high-speed switched or routed networks. sFlow technology randomly samples network packets and sends the samples to a monitoring system. In a Junos Fusion Enterprise, you can configure sFlow technology on the aggregation device to continuously monitor traffic on all extended interfaces simultaneously.

Many sFlow technology concepts for standalone switches also apply to sFlow technology on a Junos Fusion Enterprise. See [Understanding How to Use sFlow Technology for Network Monitoring on an EX Series Switch](#) for a detailed overview of sFlow on standalone EX Series switches.

Understanding the sFlow Sampling Mechanism on a Junos Fusion Enterprise

sFlow technology uses the following two sampling mechanisms:

- Packet-based sampling: Samples one packet out of a specified number of packets from an interface enabled for sFlow technology.
- Time-based sampling: Samples interface statistics at a specified interval from an interface enabled for sFlow technology.

The sampling information is used to create a network traffic visibility picture. The Juniper Networks Junos operating system (Junos OS) fully supports the sFlow standard described in RFC 3176, *InMon Corporation's sFlow: A Method for Monitoring Traffic in Switched and Routed Networks*.

NOTE: sFlow technology on the switches samples only raw packet headers. A raw Ethernet packet is the complete Layer 2 network frame.

An sFlow monitoring system consists of an sFlow agent (embedded in the switch), and a centralized collector. The sFlow agent's two main activities are random sampling and statistics gathering. The sFlow agent combines interface counters and flow samples and sends them across the network to the sFlow collector in UDP datagrams, directing those datagrams to the IP address and UDP destination port of the collector. Each datagram contains the following information:

- The IP address of the sFlow agent
- The number of samples
- The interface through which the packets entered the agent
- The interface through which the packets exited the agent
- The source and destination interface for the packets
- The source and destination VLAN for the packets

Like all features in a Junos Fusion Enterprise, sFlow technology is configured from the aggregation devices.

BEST PRACTICE: We recommend the following consideration guidelines for sFlow technology in a Junos Fusion Enterprise:

- Configure sFlow technology on both aggregation devices.
- Configure the same sampling rates on all the extended ports. If you configure different sampling rates, then the lowest value is used for all ports. Note that counter samples are sent from both aggregation devices for an extended port.
- Use the configuration sync feature to synchronize the configuration across the aggregation devices.
- After synchronization is finished, make sure that the collector is reachable from both aggregation devices.

Limitations for sFlow on a Junos Fusion Enterprise

Consider the following limitations when you configure sFlow technology on a Junos Fusion Enterprise:

- You cannot configure sFlow technology on a link aggregation group (LAG), but you can configure it individually on a LAG member interface.
- You cannot configure sFlow technology on a cascade port.
- When using the configuration sync feature, sFlow collector statistics are not synced between the aggregation devices.
- Adaptive sampling is not supported for extended ports. Given this limitation, make sure that you configure the appropriate sampling rate for your configuration so that there is no congestion for CPU traffic.

Understanding Port Mirroring Analyzers on a Junos Fusion Enterprise

IN THIS SECTION

- [Port Mirroring Analyzers on a Junos Fusion Enterprise Overview | 791](#)
- [Understanding the Configuration of Analyzers in a Junos Fusion Enterprise | 791](#)
- [Limitations for Port Mirroring Analyzers on a Junos Fusion Enterprise | 792](#)

This topic describes port mirroring analyzers in a Junos Fusion Enterprise.

This topic covers:

Port Mirroring Analyzers on a Junos Fusion Enterprise Overview

Port mirroring can be used for traffic analysis on routers and switches that, unlike hubs, do not broadcast packets to every port on the destination device. Port mirroring sends copies of all packets or policy-based sample packets to local or remote analyzers where you can monitor and analyze the data.

In a Junos Fusion Enterprise, analyzers are used to mirror traffic from an extended port on a satellite device to an output interface or VLAN. The output interface or VLAN can be connected to the aggregation device or to an extended port on a satellite device.

You can configure an analyzer to mirror:

- Bridged packets (Layer 2 packets)
- Routed packets (Layer 3 packets)

Many port mirroring analyzer concepts for standalone switches also apply to port mirroring analyzers on Junos Fusion Enterprise. See [Understanding Port Mirroring Analyzers](#) for a detailed overview of port mirroring analyzers on standalone switches.

Understanding the Configuration of Analyzers in a Junos Fusion Enterprise

Like all features in a Junos Fusion Enterprise, port mirroring analyzers are configured from the aggregation devices.

The mirroring options in a Junos Fusion Enterprise are:

- Mirror traffic from a native interface to an extended port.
- Mirror traffic from an extended port on one satellite device to an extended port on another satellite device.
- Mirror traffic from an extended port to a native interface. Configure remote mirroring for this scenario—that is, configure an analyzer output VLAN with an ICL and a native interface as remote-mirroring VLAN members in one aggregation device and an ICL as a remote-mirroring VLAN member in the peer aggregation device, so that both aggregation devices can mirror to the native interface.

NOTE: Even if the mirroring source and destination are on the same satellite device, the mirrored traffic always goes back to the aggregation device.

BEST PRACTICE: We recommend the following configuration guidelines for analyzers in a Junos Fusion Enterprise:

- Configure remote mirroring.
- Configure an analyzer output VLAN with both an ICL (interchassis link) and the mirror destination as VLAN members, so that mirrored traffic can travel through the ICL to the peer aggregation device if the mirror destination is not directly reachable on the local aggregation device. This is applicable in scenarios where the mirror destination is single-homed or a dual-homed satellite device and the cascade port is down on the local aggregation device.
- Use the configuration sync feature to synchronize the configuration across aggregation devices.

Limitations for Port Mirroring Analyzers on a Junos Fusion Enterprise

Consider the following limitations when you configure port mirroring analyzers on a Junos Fusion Enterprise:

- You cannot mirror a cascade port or an ICL. (See the configuration guidelines in [Understanding Port Mirroring Analyzers](#) for other port types that cannot be mirrored.)
- An analyzer input VLAN mirrors all interfaces in the VLAN *except* the ICL in the VLAN. This limitation keeps mirrored traffic from causing congestion in the ICL.

RELATED DOCUMENTATION

| [Understanding Port Mirroring Analyzers](#)

Junos Fusion Enterprise Private VLANs

IN THIS CHAPTER

- [Understanding Private VLANs on a Junos Fusion Enterprise | 793](#)

Understanding Private VLANs on a Junos Fusion Enterprise

IN THIS SECTION

- [PVLANS on a Junos Fusion Enterprise Overview | 793](#)
- [Understanding the Configuration of PVLANS in a Junos Fusion Enterprise | 794](#)
- [Limitations for PVLANS on a Junos Fusion Enterprise | 795](#)

This topic describes private VLANs (PVLANS) in a Junos Fusion Enterprise.

This topic covers:

PVLANS on a Junos Fusion Enterprise Overview

Junos Fusion Enterprise (JFE) supports private VLANs (PVLANS). PVLANS on a Junos Fusion Enterprise are an extension of PVLANS on standalone switches that enables PVLANS on extended ports on satellite devices.

PVLANS are useful for restricting the flow of broadcast and unknown unicast traffic and for limiting the known communication between known hosts. PVLAN is a standard introduced by RFC 5517 to achieve port or device isolation in a Layer 2 VLAN by partitioning a VLAN broadcast domain (also called a *primary VLAN*) into smaller subdomains (also called *secondary VLANs*).

PVLANS can be used for such purposes as:

- To help ensure the security of service providers sharing a server farm
- To provide security to subscribers of various service providers sharing a common metropolitan area network
- To achieve isolation within the same subnet in a very large enterprise network

In a Junos Fusion Enterprise, PVLANS can be configured on ports belonging to the aggregation device or to an extended port on a satellite device.

PVLAN concepts for standalone switches apply to PVLANS on a Junos Fusion Enterprise. See [Understanding Private VLANs](#).

NOTE: Some “Guidelines and Restrictions for PVLANS” in [Understanding Private VLANs](#), however, do not apply to PVLANS on a Junos Fusion Enterprise for the following reasons:

- Restrictions on use of MSTP and VSTP—Spanning-tree protocols are not supported on Junos Fusion Enterprise.
- Restrictions on use of [mac-table-size](#), [no-mac-learning](#), [mac-statistics](#), and [interface-mac-limit](#)—These statements are not supported on Junos Fusion Enterprise.

Understanding the Configuration of PVLANS in a Junos Fusion Enterprise

Like all features in a Junos Fusion Enterprise, PVLANS are configured from the aggregation devices.

Junos Fusion Enterprise PVLAN topologies support the following:

- Multiple satellite devices can be clustered into a group and cabled into the JFE as a group instead of as individual satellite devices.
- Aggregation device *native ports* (that is, ports on the aggregation device that are not acting as cascade ports) or satellite device extended ports can act as promiscuous ports, isolated ports, or community VLAN ports. See [Understanding Private VLANs](#) for definitions of PVLAN port types. These port types are also described in RFC 5517.
- The promiscuous port can be attached to a core switch or router through physical interfaces or aggregated links.
- PVLANS are supported in dual aggregation device JFEs.

BEST PRACTICE: We recommend the following configuration guidelines for PVLANS in a Junos Fusion Enterprise:

- In a dual-aggregation device JFE, we recommend that you use the interchassis link (ICL) as the inter-switch link for PVLAN inter-switching. Although any port link in the JFE *could* serve as the inter-switch link, the high-bandwidth requirements on the inter-switch link make the ICL the best choice.
- PVLAN ports can span across the switches in the JFE. We recommend that you interconnect 10-gigabit or 40-gigabit ports as they provide the high bandwidth needed for PVLAN trunk traffic.

Limitations for PVLANS on a Junos Fusion Enterprise

Consider the following limitations when you configure PVLANS on a Junos Fusion Enterprise:

- PVLANS on a JFE do not work if local switching is enabled on satellite devices.
- You cannot change the role of a PVLAN bridge domain from primary VLAN to secondary VLAN or the reverse in a single commit cycle.
- Protocols configured per VLAN cannot be configured on secondary VLANs. Secondary VLANs inherit protocol configurations from the primary VLAN.

RELATED DOCUMENTATION

| [Understanding Private VLANs](#)

Power over Ethernet, LLDP, and LLDP-MED on Junos Fusion Enterprise

IN THIS CHAPTER

- [Understanding Power over Ethernet in a Junos Fusion | 796](#)
- [Understanding LLDP and LLDP-MED on a Junos Fusion | 799](#)
- [Configuring Power over Ethernet in a Junos Fusion | 801](#)
- [Verifying PoE Configuration and Status for a Junos Fusion \(CLI Procedure\) | 806](#)

Understanding Power over Ethernet in a Junos Fusion

IN THIS SECTION

- [Power over Ethernet in a Junos Fusion Overview | 797](#)
- [Understanding the Role of the Aggregation Devices for PoE Support in a Junos Fusion | 797](#)
- [Understanding the Role of the Satellite Devices for PoE Support in a Junos Fusion | 797](#)
- [Understanding PoE Configuration in a Junos Fusion | 798](#)
- [Understanding PoE Support Standards for Extended Ports in a Junos Fusion | 798](#)
- [Understanding Maximum PoE Power Budgets in a Junos Fusion | 798](#)
- [Understanding PoE Controller Software in a Junos Fusion | 799](#)
- [Understanding PoE Power Allocation Configuration Options in a Junos Fusion | 799](#)

This topic describes Power over Ethernet (PoE) in a Junos Fusion.

This topic covers:

Power over Ethernet in a Junos Fusion Overview

Power over Ethernet (PoE) enables electric power, along with data, to be passed over a copper Ethernet LAN cable. Powered devices—such as *VoIP* telephones, wireless access points, video cameras, and point-of-sale devices—that support PoE can receive power safely from the same access ports that are used to connect personal computers to the network. This reduces the amount of wiring in a network, and it also eliminates the need to position a powered device near an AC power outlet, making network design more flexible and efficient.

In a Junos Fusion, PoE is used to carry electric power from an extended port on a satellite device to a connected device. An extended port is any network-facing port on a satellite device in a Junos Fusion.

Many PoE concepts for standalone switches also apply to PoE on Junos Fusion. See [Understanding PoE on EX Series Switches](#) for a detailed overview of PoE on standalone EX Series switches.

Understanding the Role of the Aggregation Devices for PoE Support in a Junos Fusion

An aggregation device is responsible for configuring, monitoring, and maintaining all configurations for all extended ports in a Junos Fusion, including PoE. Therefore, all commands used to configure, monitor, and maintain PoE in a Junos Fusion are entered from the aggregation device.

An extended port on the satellite device must support PoE to enable PoE in a Junos Fusion. No hardware limitations for PoE support are introduced by the aggregation device in a Junos Fusion.

NOTE: PoE is supported in a Junos Fusion Provide Edge and a Junos Fusion Enterprise despite not being supported in MX series routers or standalone EX9200 switches. All MX series routers and EX9200 switch models, when configured into the aggregation device role in a Junos Fusion, can enable PoE Junos Fusion because the PoE hardware support is supported on the satellite devices.

Understanding the Role of the Satellite Devices for PoE Support in a Junos Fusion

A satellite device in a Junos Fusion provides PoE hardware support in a Junos Fusion. Each satellite device in a Junos Fusion that supports PoE has its own PoE controller. The PoE controller keeps track of the PoE power consumption on the satellite device and allocates power to PoE extended ports. The maximum PoE power consumption for a satellite device—the total amount of power available for the satellite device's PoE controller to allocate to all of the satellite device's PoE interfaces—is determined individually by the switch model of the satellite devices and by the power supply or supplies installed in that satellite device.

In allocating power, the satellite device's PoE controller cannot exceed the satellite device's maximum PoE power availability.

The maximum PoE power consumption varies by satellite device in a Junos Fusion , because the hardware specifications of the satellite devices determine the maximum PoE power availability.

See [Understanding PoE on EX Series Switches](#) for a listing of the PoE power consumption limit for each EX Series switch model and power supply configuration.

Understanding PoE Configuration in a Junos Fusion

Like all features in a Junos Fusion, PoE is configured from the aggregation devices.

In dual aggregation device topologies, the PoE configurations should match identically on both aggregation devices.

PoE in a Junos Fusion works by periodically checking the PoE configuration on each aggregation device, and updating the configuration when a PoE change is identified. If the aggregation devices have different PoE configurations, the PoE configurations for the Junos Fusion will continually change because the Junos Fusion always uses the PoE configuration of the last aggregation device that was checked.

Understanding PoE Support Standards for Extended Ports in a Junos Fusion

The extended port hardware—specifically, the extended port hardware interface on the satellite device in the Junos Fusion —must support PoE to enable PoE in a Junos Fusion.

All extended ports that support PoE on satellite devices in a Junos Fusion support the IEEE 802.3at PoE + standard. The IEEE 802.3at PoE+ standard allows an extended port that supports PoE to provide up to 30 W of power to a connected device.

Understanding Maximum PoE Power Budgets in a Junos Fusion

The maximum PoE power budgets are determined for each individual satellite device in a Junos Fusion.

Maximum PoE power budgets for a satellite device vary by the switch model and power supply configuration of the satellite device.

To learn the maximum PoE power supply budget for a satellite device:

- See [Understanding PoE on EX Series Switches](#) for a table of maximum power supply budgets by switch device model.
- Enter the **show poe controller** command from your aggregation device and view the Maximum Power output.

Understanding PoE Controller Software in a Junos Fusion

All switches that support PoE have a PoE controller that runs PoE controller software, including switches acting as satellite devices in a Junos Fusion.

PoE controller software is bundled with Junos OS. PoE controller software should be updated before installing a switch as a satellite device in a Junos Fusion.

For information on PoE controller software requirements in a Junos Fusion Enterprise, see [Understanding Junos Fusion Enterprise Software and Hardware Requirements](#).

For information on PoE controller software requirements in a Junos Fusion Provider Edge, see *Understanding Junos Fusion Provider Edge Software and Hardware Requirements*

For information on checking or upgrading the PoE controller software version, see [Upgrading the PoE Controller Software](#).

Understanding PoE Power Allocation Configuration Options in a Junos Fusion

Junos Fusion supports several optional features that help manage PoE power allocation on the satellite devices.

The PoE power allocation options are discussed in greater detail in [Understanding PoE on EX Series Switches](#).

RELATED DOCUMENTATION

[Configuring Power over Ethernet in a Junos Fusion | 801](#)

[Verifying PoE Configuration and Status for a Junos Fusion \(CLI Procedure\) | 806](#)

Understanding LLDP and LLDP-MED on a Junos Fusion

IN THIS SECTION

- [LLDP and LLDP-MED in a Junos Fusion Overview | 800](#)
- [Understanding LLDP and LLDP-MED Configuration and Traffic Handling in a Junos Fusion | 800](#)

This topic describes Link Layer Discovery Protocol (LLDP) and Link Layer Discovery Protocol–Media Endpoint Discovery (LLDP-MED) in a Junos Fusion.

This topic covers:

LLDP and LLDP-MED in a Junos Fusion Overview

LLDP and LLDP-MED are used to learn and distribute device information on network links. The information enables the switch to quickly identify a variety of devices, resulting in a LAN that interoperates smoothly and efficiently.

LLDP-capable devices transmit information in type, length, and value (TLV) messages to neighbor devices. Device information can include information such as chassis and port identification and system name and system capabilities. The TLVs leverage this information from parameters that have already been configured in the Junos operating system (Junos OS).

Many LLDP and LLDP-MED concepts for standalone EX Series switches that support the features also apply to LLDP and LLDP-MED on Junos Fusion. See [Understanding LLDP and LLDP-MED on EX Series Switches](#) for a detailed overview of LLDP and LLDP-MED on standalone EX Series switches.

NOTE: LLDP-MED goes one step further than LLDP, exchanging IP-telephony messages between the switch and the IP telephone. LLDP-MED is an important access layer switch feature that is supported in a Junos Fusion despite not being supported on a standalone EX9200 switch.

Understanding LLDP and LLDP-MED Configuration and Traffic Handling in a Junos Fusion

LLDP and LLDP-MED traffic is generally handled the same in a Junos Fusion or a standalone series switch. LLDP and LLDP-MED configuration on an extended port in a Junos Fusion is identical for a standalone EX Series switch. See [Configuring LLDP \(CLI Procedure\)](#) or [Configuring LLDP-MED \(CLI Procedure\)](#).

The following specifications apply to the device information transmitted by LLDP and LLDP-MED in a Junos Fusion topology with two or more aggregation devices:

- Management address TLVs are merged into a single packet in such a way that the packet contains two or more management address TLVs.
- The SNMP index used as the port ID TLV is derived so that all aggregation devices receive the same index value for port IDs of extended ports.
- The system name for extended ports is the configured redundancy group name. A redundancy group has to be configured in order to enable a topology with two or more aggregation devices.

- The chassis ID is the same for all aggregation devices. If a system MAC address is defined for the redundancy group, is it used as the chassis ID. The system MAC address is configured using the `set chassis satellite-management redundancy-groups redundancy-group-name system-mac-address system-mac-address` command. If the system MAC is not configured, the chassis ID is the default MAC address, which is 00:00:00:00:00:01.

BEST PRACTICE: We recommend specifying a system MAC address if you are running LLDP or LLCP-MED traffic in your Junos Fusion topology.

RELATED DOCUMENTATION

[Configuring LLDP \(CLI Procedure\)](#)

[Configuring LLDP-MED \(CLI Procedure\)](#)

Configuring Power over Ethernet in a Junos Fusion

IN THIS SECTION

- [PoE Configurable Options | 801](#)
- [Enabling PoE | 803](#)
- [Disabling PoE | 803](#)
- [Setting the Power Management Mode | 804](#)
- [Setting the Maximum Power That Can Be Delivered from a PoE Interface | 805](#)
- [Setting the Guard Band | 805](#)
- [Setting the PoE Interface Priority | 806](#)

PoE Configurable Options

[Table 42 on page 802](#) shows the configurable PoE options and their default settings in a Junos Fusion.

Some PoE options can be configured globally and per interface. In cases where a PoE interface setting is different from a global PoE setting, the PoE interface setting is configured on the interface.

Table 42: Configurable PoE Options and Default Settings

Option	Default	Description
disable (Power over Ethernet)	Not included in default configuration. NOTE: PoE ports are disabled by default in a Junos Fusion.	Disables PoE on the interface if PoE was enabled. The interface maintains network connectivity but no longer supplies power to a connected powered device. Power is not allocated to the interface.
guard-band	0 W	Reserves a specified amount of power from the PoE power budget for possible spikes in PoE power consumption. In a Junos Fusion, the guard band can be 0 to 19 W.
management	class	Sets the PoE power management mode for the extended port. The power management mode determines how power to a PoE extended port is allocated: <ul style="list-style-type: none"> • class—In this mode, the power allocated to a PoE extended port is determined by the class of the connected powered device. If there is no powered device connected, standard 15.4W power is allocated on the interface. • static—The maximum power delivered by an interface is statically configured and is independent of the class of the connected powered device. The maximum power is allocated to the interface even if a powered device is not connected.
maximum-power (Interface)	30.0 W (PoE+, IEEE 802.3at)	Sets the maximum power that can be delivered by a PoE interface when the power management mode is static . In a Junos Fusion, all extended ports support PoE+ so the maximum power is up to 30 W. This setting is ignored if the power management mode is class .

Table 42: Configurable PoE Options and Default Settings (*Continued*)

Option	Default	Description
priority (Power over Ethernet)	low	Sets an interface's power priority to either low or high . If power is insufficient for all PoE interfaces, the PoE power to low-priority interfaces is shut down before power to high-priority interfaces is shut down. Among interfaces that have the same assigned priority, the power priority is determined by port number, with lower-numbered ports having higher priority.

Enabling PoE

PoE is disabled by default for all extended ports in a Junos Fusion.

To enable PoE on all PoE-supported interfaces:

```
[edit]
user@aggregation-device# set poe interface all-extended
```

To enable PoE on a specific PoE-supported interface:

```
[edit]
user@aggregation-device# set poe interface interface-name
```

For instance, to enable PoE on extended port interface ge-100/0/24:

```
[edit]
user@aggregation-device# set poe interface ge-100/0/24
```

Disabling PoE

PoE is disabled by default in a Junos Fusion. Use this procedure to disable PoE in a Junos Fusion that has PoE previously enabled.

If PoE is enabled globally but disabled on a specific interface, PoE is disabled on the specified interface. This procedure can, therefore, be used to individually disable ports in cases where PoE is globally enabled.

If you want to disable PoE on all extended port interfaces in a Junos Fusion:

```
[edit]
user@aggregation-device# set poe interface all-extended disable
```

If you want to disable PoE on one extended port interface:

```
[edit]
user@aggregation-device# set poe interface interface-name disable
```

For instance, to disable PoE on extended port 101/0/1 in a Junos Fusion:

```
[edit]
user@aggregation-device# set poe interface 101/0/1 disable
```

If you want to enable PoE on all PoE-supported extended ports in a Junos Fusion except 101/0/10, enter the following commands:

```
[edit]
user@aggregation-device# set poe interface all-extended
user@aggregation-device# set poe interface 101/0/10 disable
```

Setting the Power Management Mode

The power management mode in a Junos Fusion is set for all extended ports in a Junos Fusion .

The default power management mode is class.

To set the power management mode to static for all PoE extended ports:

```
[edit]
user@aggregation-device# set poe management static
```

To set the power management mode back to class for all PoE extended ports:

```
[edit]
user@aggregation-device# set poe management class
```

Setting the Maximum Power That Can Be Delivered from a PoE Interface

To set the maximum power that can be delivered to a connected device using PoE when the power management mode is set to static:

```
[edit]
user@aggregation-device# set poe interface interface-name maximum-power watts
```

To configure all extended port interfaces to the same maximum power, enter **all-extended** as the *interface-name*.

For instance, to change the maximum power for all PoE extended ports configured in static power management mode to 25 watts:

```
[edit]
user@aggregation-device# set poe interface all-extended maximum-power 25
```

To change the maximum power for interface 101/0/1 to 25 watts:

```
[edit]
user@aggregation-device# set poe interface 101/0/1 maximum-power 25
```

Setting the Guard Band

One guard band is configured for all extended ports in a Junos Fusion.

To set the guard band for all extended ports in a Junos Fusion:

```
[edit]
user@aggregation-device# set poe guard-band watts
```

For instance, to set the guard-band to 19 watts for all PoE extended ports:

```
[edit]
user@aggregation-device# set poe guard-band 19
```

Setting the PoE Interface Priority

To set a PoE interface priority to high:

```
[edit]
user@aggregation-device# set poe interface interface-name priority high
```

For instance, to assign a high priority to interface 101/0/1:

```
[edit]
user@aggregation-device# set poe interface 101/0/1 priority high
```

To set a PoE interface priority to low:

```
[edit]
user@aggregation-device# set poe interface interface-name priority low
```

For instance, to assign a low priority to interface 102/0/1:

```
[edit]
user@aggregation-device# set poe interface 102/0/1 priority low
```

RELATED DOCUMENTATION

[Verifying PoE Configuration and Status for a Junos Fusion \(CLI Procedure\) | 806](#)

[Understanding Power over Ethernet in a Junos Fusion | 796](#)

Verifying PoE Configuration and Status for a Junos Fusion (CLI Procedure)

IN THIS SECTION

- [PoE Power Budgets, Consumption, and Mode on Satellite Devices | 807](#)
- [PoE Interface Configuration and Status | 808](#)

You can verify the Power over Ethernet (PoE) configuration and status on Junos Fusion.

This topic describes how to verify:

PoE Power Budgets, Consumption, and Mode on Satellite Devices

IN THIS SECTION

- Purpose | 807
- Action | 807
- Meaning | 807

Purpose

Verify the PoE configuration and status, such as the PoE power budget, total PoE power consumption, power management mode, and the supported PoE standard.

Action

Enter the following command:

```
user@aggregation-device> show poe controller
```

Controller index	Maximum power	Power consumption	Guard band	Management	Status	Lldp Priority
100	925.00W	0.00W	19W	Class	AT_MODE	Disabled
120	125.00W	6.08W	19W	Class	AT_MODE	Disabled

Meaning

- Satellite device 100 has a PoE power budget of 925 W, of which 0 W were being used by the PoE extended ports at the time the command was executed. The Guard band field shows that 19 W of power is reserved out of the PoE power budget to protect against spikes in power demand. The power management mode is class. The PoE ports on the switch support PoE+ (IEEE 802.3at).
- Satellite device 120 has a PoE power budget of 125 W, of which 6.08 W were being used by the PoE extended ports at the time the command was executed. The Guard band field shows that 19 W of

power is reserved out of the PoE power budget to protect against spikes in power demand. The power management mode is class. The PoE ports on the switch support PoE+ (IEEE 802.3at).

PoE Interface Configuration and Status

IN THIS SECTION

- Purpose | 808
- Action | 808
- Meaning | 810

Purpose

Verify that PoE interfaces are enabled and set to the correct maximum power and priority settings. Also verify current operational status and power consumption.

Action

To view configuration and status for all PoE interfaces, enter:

```
user@switch> show poe interface
Interface      Admin      Oper      Max      Priority   Power      Class
              status    status    power
ge-100/0/0    Enabled    OFF       16.0W    Low        0.0W       not-applicable
ge-100/0/1    Enabled    OFF       16.0W    Low        0.0W       not-applicable
ge-100/0/2    Enabled    OFF       16.0W    Low        0.0W       not-applicable
ge-100/0/3    Enabled    OFF       16.0W    Low        0.0W       not-applicable
ge-100/0/4    Enabled    OFF       16.0W    Low        0.0W       not-applicable
ge-100/0/5    Enabled    OFF       16.0W    Low        0.0W       not-applicable
ge-100/0/6    Enabled    OFF       16.0W    Low        0.0W       not-applicable
ge-100/0/7    Enabled    OFF       16.0W    Low        0.0W       not-applicable
ge-100/0/8    Enabled    OFF       16.0W    Low        0.0W       not-applicable
ge-100/0/9    Enabled    OFF       16.0W    Low        0.0W       not-applicable
ge-100/0/10   Enabled    OFF       16.0W    Low        0.0W       not-applicable
ge-100/0/11   Enabled    OFF       16.0W    Low        0.0W       not-applicable
ge-100/0/12   Enabled    OFF       16.0W    Low        0.0W       not-applicable
ge-100/0/13   Enabled    OFF       16.0W    Low        0.0W       not-applicable
ge-100/0/14   Enabled    OFF       16.0W    Low        0.0W       not-applicable
ge-100/0/15   Enabled    OFF       16.0W    Low        0.0W       not-applicable
```

ge-100/0/16	Enabled	OFF	16.0W	Low	0.0W	not-applicable
ge-100/0/17	Enabled	OFF	16.0W	Low	0.0W	not-applicable
ge-100/0/18	Enabled	OFF	16.0W	Low	0.0W	not-applicable
ge-100/0/19	Enabled	OFF	16.0W	Low	0.0W	not-applicable
ge-100/0/20	Enabled	OFF	16.0W	Low	0.0W	not-applicable
ge-100/0/21	Enabled	OFF	16.0W	Low	0.0W	not-applicable
ge-100/0/22	Enabled	OFF	16.0W	Low	0.0W	not-applicable
ge-100/0/23	Enabled	OFF	16.0W	Low	0.0W	not-applicable
ge-100/0/24	Enabled	ON	16.0W	Low	3.7W	2
ge-100/0/25	Enabled	OFF	16.0W	Low	0.0W	not-applicable
ge-100/0/26	Enabled	OFF	16.0W	Low	0.0W	not-applicable
ge-100/0/27	Enabled	OFF	16.0W	Low	0.0W	not-applicable
ge-100/0/28	Enabled	OFF	16.0W	Low	0.0W	not-applicable
ge-100/0/29	Enabled	OFF	16.0W	Low	0.0W	not-applicable
ge-100/0/30	Enabled	OFF	16.0W	Low	0.0W	not-applicable
ge-100/0/31	Enabled	OFF	16.0W	Low	0.0W	not-applicable
ge-100/0/32	Enabled	OFF	16.0W	Low	0.0W	not-applicable
ge-100/0/33	Enabled	OFF	16.0W	Low	0.0W	not-applicable
ge-100/0/34	Enabled	OFF	16.0W	Low	0.0W	not-applicable
ge-100/0/35	Enabled	OFF	16.0W	Low	0.0W	not-applicable
ge-100/0/36	Enabled	OFF	16.0W	Low	0.0W	not-applicable
ge-100/0/37	Enabled	ON	16.0W	Low	2.0W	0
ge-100/0/38	Enabled	OFF	16.0W	Low	0.0W	not-applicable
ge-100/0/39	Enabled	OFF	16.0W	Low	0.0W	not-applicable
ge-100/0/40	Enabled	OFF	16.0W	Low	0.0W	not-applicable
ge-100/0/41	Enabled	OFF	16.0W	Low	0.0W	not-applicable
ge-100/0/42	Enabled	OFF	16.0W	Low	0.0W	not-applicable
ge-100/0/43	Enabled	OFF	16.0W	Low	0.0W	not-applicable
ge-100/0/44	Enabled	OFF	16.0W	Low	0.0W	not-applicable
ge-100/0/45	Enabled	OFF	16.0W	Low	0.0W	not-applicable
ge-100/0/46	Enabled	OFF	16.0W	Low	0.0W	not-applicable
ge-100/0/47	Enabled	OFF	16.0W	Low	0.0W	not-applicable
ge-120/0/0	Enabled	ON	16.0W	Low	3.9W	2
ge-120/0/1	Enabled	OFF	16.0W	Low	0.0W	not-applicable
ge-120/0/2	Enabled	OFF	16.0W	Low	2.0W	not-applicable
ge-120/0/3	Enabled	OFF	16.0W	Low	0.0W	not-applicable
ge-120/0/4	Enabled	OFF	16.0W	Low	0.0W	not-applicable
ge-120/0/5	Enabled	OFF	16.0W	Low	0.0W	not-applicable
ge-120/0/6	Enabled	ON	16.0W	Low	0.0W	4
ge-120/0/7	Enabled	OFF	0.0W	Low	0.0W	not-applicable
ge-120/0/8	Enabled	OFF	0.0W	Low	0.0W	not-applicable
ge-120/0/9	Enabled	OFF	0.0W	Low	0.0W	not-applicable
ge-120/0/10	Enabled	OFF	0.0W	Low	0.0W	not-applicable

```
ge-120/0/11  Enabled    OFF    0.0W    Low        0.0W        not-applicable
<additional output removed for brevity>
```

To view configuration and status for a single PoE interface, enter:

```
user@switch> show poe interface ge-120/0/0
PoE interface status:
PoE interface           : ge-120/0/0
Administrative status   : Enabled
Operational status     : ON
Power limit on the interface : 7.0W
Priority                 : Low
Power consumed          : 3.9W
Class of power device   :      2
PoE Mode                : 802.3at
```

Meaning

The command output shows the status and configuration of interfaces. For example, the interface 120/0/0 is administratively enabled. Its operational status is **ON**; that is, the interface is currently delivering power to a connected powered device. The maximum power allocated to the interface is 7.0 W. The interface has a low PoE power priority. At the time the command was executed, the powered device was consuming 3.9 W. The class of the powered device is class 2. If the PoE power management mode is class, the class of the powered device determines the maximum power allocated to the interface, which is 7 W in the case of class 2 devices.

The PoE Mode field indicates that the interface supports IEEE 802.3at (PoE+).

RELATED DOCUMENTATION

[Configuring Power over Ethernet in a Junos Fusion | 801](#)

[Understanding Power over Ethernet in a Junos Fusion | 796](#)

Configuration Statements for Power over Ethernet and Power Supply Management on Junos Fusion Enterprise

IN THIS CHAPTER

- [disable \(Power over Ethernet\) | 811](#)
- [guard-band | 813](#)
- [interface \(Power over Ethernet\) | 815](#)
- [management | 816](#)
- [maximum-power \(Interface\) | 819](#)
- [n-plus-n \(satellite-management\) | 821](#)
- [poe | 823](#)
- [priority \(Power over Ethernet\) | 825](#)
- [psu \(satellite-management\) | 827](#)
- [redundancy \(satellite-management\) | 828](#)

disable (Power over Ethernet)

IN THIS SECTION

- [Syntax | 812](#)
- [Hierarchy Level | 812](#)
- [Description | 812](#)
- [Required Privilege Level | 812](#)
- [Release Information | 812](#)

Syntax

```
disable;
```

Hierarchy Level

```
[edit poe                interface (all | all-extended | interface-name)],
[edit poe                interface (all | all-extended | interface-name) telemetries],
[edit poe                notification-control fpc slot-number]
```

Description

Disable a PoE interface, disable the collection of power consumption data for a PoE interface, or disable the generation of the PoE SNMP traps. The action of the `disable` statement depends on which statement it is used with:

- When used with **interface**—Disable the PoE capability of this interface. The interface operates as a standard network access interface, and power is no longer allocated to it from the PoE power budget. Although the PoE capability is disabled, the PoE configuration for the interface is retained. To reenble the PoE capability of this interface, delete the `disable` statement from the **interface** entry in the configuration.
- When used with **telemetries**—Disable the collection of PoE power consumption records for this interface. Any previously collected records are deleted. However, the **telemetries** configuration is retained, including the values for **interval** and **duration**. To reenble record collection, delete the `disable` statement from the **telemetries** entry in the configuration.
- When used with **notification-control**—Disable the generation of PoE SNMP traps. To reenble PoE traps, delete the `disable` statement from the **notification-control** entry in the configuration.

Required Privilege Level

system—To view this statement in the configuration.

system-control—To add this statement to the configuration.

Release Information

Statement introduced in Junos OS Release 9.0.

all-extended option introduced in Junos OS Release 16.1R1.

Statement introduced in Junos OS Release 17.2R1 for a Junos Fusion Provider Edge.

RELATED DOCUMENTATION

[Example: Configuring PoE Interfaces with Different Priorities on an EX Series Switch](#)

[Configuring PoE Interfaces on EX Series Switches](#)

[Configuring Power over Ethernet in a Junos Fusion](#) | 801

guard-band

IN THIS SECTION

- [Syntax](#) | 813
- [Hierarchy Level](#) | 813
- [Description](#) | 814
- [Options](#) | 814
- [Required Privilege Level](#) | 814
- [Release Information](#) | 814

Syntax

```
guard-band watts;
```

Hierarchy Level

```
[edit poe],  
[edit poe (all | fpc slot-number)]
```

Description

Reserve a specified amount of power from the PoE power budget for the switch, line card, or satellite device in case of a spike in PoE consumption.

Options

watts—Amount of power to be reserved in case of a spike in PoE consumption.

- **Range:** 0 through 19 for all switches except EX6200 and EX8200 switches.

0 through 19 for ACX2000 routers.

0 through 15 for EX6200 and EX8200 switches.

0 through 19 for satellite devices in a Junos Fusion.

- **Default:** 0

Required Privilege Level

system—To view this statement in the configuration.

system-control—To add this statement to the configuration.

Release Information

Statement introduced in Junos OS Release 9.0.

Statement introduced in Junos OS Release 12.2 for ACX2000 Universal Metro Routers.

Statement introduced in Junos OS Release 17.2R1 for a Junos Fusion Provider Edge.

RELATED DOCUMENTATION

[Configuring PoE Interfaces on EX Series Switches](#)

[Configuring Power over Ethernet in a Junos Fusion](#) | 801

interface (Power over Ethernet)

IN THIS SECTION

- [Syntax | 815](#)
- [Hierarchy Level | 815](#)
- [Description | 815](#)
- [Options | 816](#)
- [Required Privilege Level | 816](#)
- [Release Information | 816](#)

Syntax

```
interface (all | all-extended | interface-name) {  
    af-mode;  
    disable;  
    maximum-power watts;  
    priority (high | low);  
    telemetries {  
        disable;  
        duration hours;  
        interval minutes;  
    }  
}
```

Hierarchy Level

[edit [poe](#)]

Description

Specify a PoE interface to be configured.

Options

all—All PoE interfaces on the switch that have not been individually configured for PoE. If a PoE interface has been individually configured, that configuration overrides any settings specified with **all**.

all-extended—(Junos Fusion only) All PoE extended port interfaces in a Junos Fusion that have not been individually configured for PoE. If a PoE interface has been individually configured, that configuration overrides any settings specified with **all-extended**.

interface-name—Name of the specific interface being configured.

If you use the `interface` statement without any substatements, default values are used for the remaining statements.

The remaining statements are explained separately. See [CLI Explorer](#).

Required Privilege Level

`system`—To view this statement in the configuration.

`system-control`—To add this statement to the configuration.

Release Information

Statement introduced in Junos OS Release 9.0.

Statement introduced in Junos OS Release 17.2R1 for a Junos Fusion Provider Edge.

RELATED DOCUMENTATION

[Configuring PoE Interfaces on EX Series Switches](#)

[Configuring Power over Ethernet in a Junos Fusion](#) | 801

management

IN THIS SECTION

● [Syntax](#) | 817

● [Hierarchy Level](#) | 817

- Description | 817
- Default | 817
- Options | 817
- Required Privilege Level | 818
- Release Information | 818

Syntax

```
management (class | static | high-power);
```

Hierarchy Level

```
[edit poe],  
[edit poe (all | fpc slot-number)]
```

Description

Designate how the PoE controller allocates power to the PoE interfaces.

Default

class

Options

- `class`—The amount of power allocated to the interface is based on the class of the connected powered device. If LLDP power negotiation is enabled, the powered device can request more or less power. LLDP power negotiation is enabled by default in class management mode.

If LLDP power negotiation is disabled, the power allocation is determined solely by the class of the connected powered device. If there is no powered device connected, standard 15.4W power is allocated on the interface. For more information about disabling LLDP power negotiation, see [Device Discovery Using LLDP and LLDP-MED on Switches](#).

- **static**—The amount of power allocated to the interface is determined by the value of the [maximum-power](#) statement, not the class of the connected powered device. This amount is allocated even when a powered device is not connected to the interface, ensuring that power is available when needed.

NOTE: Static mode is not supported in PoE-bt.

- **high-power**—(ACX2000 routers only) ACX2000 PoE interfaces support power delivery of up to 65 W per port using all four pairs of Ethernet RJ45 cables. Traditional PoE ports use only two pairs of Ethernet cable for power delivery. According to the IEEE 802.3af standard, each port can deliver a maximum power of up to 32 W. With high-power mode of power delivery over all four pairs, the power sourcing equipment (PSE) has an option to deliver up to 65 W per port, provided the powered devices request this high power over all four pairs of the Ethernet cable. By default, high-power mode is not enabled and has to be explicitly enabled. When the PoE controller is configured for high-power mode, the PoE controller does not deliver power to normal powered devices that request power over two pairs.

Required Privilege Level

system—To view this statement in the configuration.

system-control—To add this statement to the configuration.

Release Information

Statement introduced in Junos OS Release 9.0.

Statement introduced in Junos OS Release 17.2R1 for a Junos Fusion Provider Edge.

RELATED DOCUMENTATION

[Understanding PoE on EX Series Switches](#)

[Configuring PoE Interfaces on EX Series Switches](#)

[Configuring Power over Ethernet in a Junos Fusion](#) | 801

maximum-power (Interface)

IN THIS SECTION

- [Syntax | 819](#)
- [Hierarchy Level | 819](#)
- [Description | 819](#)
- [Options | 820](#)
- [Required Privilege Level | 821](#)
- [Release Information | 821](#)

Syntax

```
maximum-power watts;
```

Hierarchy Level

```
[edit poe interface (all | all-extended | interface-name)]
```

Description

Configure the maximum amount of power that the switch can supply to the PoE port. The maximum power configuration is valid when the PoE power management is in static mode. If PoE power management is in class mode, which is the default, the maximum power configuration will have no effect on the power allocation. For more information on power management configuration options, see [management](#).

NOTE: Maximum power configuration is not supported in PoE-bt (IEEE 802.3bt).

NOTE: A standalone switch's default setting and range for maximum power does not change if the switch is configured as a satellite device in a Junos Fusion. For instance, an EX4300 switch has a 30W default and a range of 0.0 through 30.0 W when configured as a standalone switch and when it is configured into a satellite device in a Junos Fusion.

Options

watts—The maximum power in watts that can be supplied to the ports.

For EX2200, EX3300, EX4200, EX4300, EX4600, EX6200, and EX8200 switches:

- **Range:** 0.0 through 30.0
- **Default:** 15.4 W for ports that support IEEE 802.3af and 30 W for ports that support IEEE 802.3at

For EX3200 switches:

- **Range:** 0.0 through 18.6
- **Default:** 15.4 W

NOTE: EX4600 switches support PoE only when operating in a mixed Virtual Chassis with EX4300 switches.

For ACX2000 routers:

- **Range:** 1 through 65 W
- **Default:** 32 W

NOTE: The **maximum-power** setting permitted by the CLI might be greater than the maximum power a given PoE port can deliver. For example, the CLI permits you to set any PoE port on an EX8200 line card to 30 W; however, only ports 0 through 11 support 30 W. Similarly, the CLI permits you to set any PoE port on an EX4200 switch to 30 W, but some models of EX4200 switch support only 18.6 W per port. If you configure a **maximum-power** value that is greater than the maximum power supported by a port, the power allocated to the port will be the maximum supported.

If you use the **all** option to set **maximum-power** to a value greater than 15.4 W on all interfaces on an EX8200 line card, the maximum power allocated to all ports is 15.4 W.

NOTE: Support for a maximum of 18.6 W per port instead of 15.4 W per port on EX3200 switches and P and T models of EX4200 switch requires Junos OS Release 11.1 or later. In addition to requiring an upgrade of Junos OS to Release 11.1 or later, switches that are running an earlier release of Junos OS release require the PoE controller software be upgraded as described in [Upgrading the PoE Controller Software](#). If the controller software is not upgraded and you set **maximum-power** to a value greater than 15.4 W, the configuration is accepted when you commit it, but the actual power allocated to the port will be 15.4 W.

NOTE: On ACX2000 routers, the power sourcing equipment (PSE) delivers up to 65 W per port, provided the management mode is set to high-power mode, by using the high-power option at the [edit poe management] hierarchy level. By default, the management mode is set to static. In the static mode, the PSE can deliver power up to 32 W.

Required Privilege Level

system—To view this statement in the configuration.

system-control—To add this statement to the configuration.

Release Information

Statement introduced in Junos OS Release 9.0.

RELATED DOCUMENTATION

[Configuring PoE Interfaces on EX Series Switches](#)

[Configuring Power over Ethernet in a Junos Fusion](#) | 801

n-plus-n (satellite-management)

IN THIS SECTION

● [Syntax](#) | 822

- [Hierarchy Level | 822](#)
- [Description | 822](#)
- [Required Privilege Level | 822](#)
- [Release Information | 822](#)

Syntax

```
n-plus-n
```

Hierarchy Level

```
[edit chassis satellite-management psu redundancy]
```

Description

Configure $N+N$ power supply redundancy for the satellite devices in a Junos Fusion.

Required Privilege Level

interface—To view this statement in the configuration.

interface-control—To add this statement to the configuration.

Release Information

Statement introduced in Junos OS Release 16.1R1.

RELATED DOCUMENTATION

| [Understanding Power over Ethernet in a Junos Fusion | 796](#)

poe

IN THIS SECTION

- Syntax | 823
- Hierarchy Level | 825
- Description | 825
- Required Privilege Level | 825
- Release Information | 825

Syntax

For switches other than EX6200 and EX8200 switches:

```

poe {
    guard-band watts;
    interface (all | interface-name) {
        disable;
        maximum-power watts;
        priority (high | low);
        telemetries {
            disable;
            duration hours;
            interval minutes;
        }
    }
}
lldp-priority;
management (class | static);
notification-control {
    fpc slot-number {
        disable;
    }
}
}

```

For a Junos Fusion:

```

poe {
    guard-band watts;
    interface (all-extended | interface-name) {
        disable;
        maximum-power watts;
        priority (high | low);
    }
    management (class | static);
}

```

For EX6200 and EX8200 switches:

```

poe {
    fpc ( all | slot-number) {
        guard-band watts;
        lldp-priority;
        management (class | static);
        maximum-power watts;
    }
    interface (all | interface-name) {
        af-mode;
        disable;
        maximum-power watts;
        priority (high | low);
        telemetries {
            disable;
            duration hours;
            interval minutes;
        }
    }
}
notification-control {
    fpc slot-number {
        disable;
    }
}
}

```

Hierarchy Level

[edit]

Description

Configure PoE options. PoE ports on Juniper network switches provide power to PoE-enabled devices only when straight-through cables are used. Power is not provided when crossover cables are used.

The remaining statements are explained separately. See [CLI Explorer](#).

Required Privilege Level

system—To view this statement in the configuration.

system-control—To add this statement to the configuration.

Release Information

Statement introduced in Junos OS Release 9.0.

Statement introduced in Junos OS Release 17.2R1 for a Junos Fusion Provider Edge.

RELATED DOCUMENTATION

[Configuring PoE Interfaces on EX Series Switches](#)

[Configuring Power over Ethernet in a Junos Fusion](#) | 801

priority (Power over Ethernet)

IN THIS SECTION

- [Syntax](#) | 826
- [Hierarchy Level](#) | 826
- [Description](#) | 826
- [Default](#) | 826

- [Options | 826](#)
- [Required Privilege Level | 827](#)
- [Release Information | 827](#)

Syntax

```
priority (low | high);
```

Hierarchy Level

```
[edit poe interface (interface-name | all | all-extended)]
```

Description

Set the power priority for individual interfaces when there is insufficient power for all PoE interfaces. If the switch needs to shut down powered devices because PoE demand exceeds the PoE budget, low-priority devices are shut down before high-priority devices. Among interfaces that have the same assigned priority, priority is determined by port number, with lower-numbered ports having higher priority.

Default

low

Options

high—Specifies that this interface is to be treated as high-priority in terms of power allocation. If the switch needs to shut down powered devices because PoE demand exceeds the PoE budget, power is not shut down on this interface until it has been shut down on all the low-priority interfaces.

low—Specifies that this interface is to be treated as low-priority in terms of power allocation. If the switch needs to shut down powered devices because PoE demand exceeds the PoE budget, power is shut down on this interface before it is shut down on high-priority interfaces.

Required Privilege Level

system—To view this statement in the configuration.

system-control—To add this statement to the configuration.

Release Information

Statement introduced in Junos OS Release 9.0.

Statement introduced in Junos OS Release 17.2R1 for a Junos Fusion Provider Edge.

RELATED DOCUMENTATION

[Example: Configuring PoE Interfaces with Different Priorities on an EX Series Switch](#)

[Configuring PoE Interfaces on EX Series Switches](#)

[Configuring Power over Ethernet in a Junos Fusion](#) | 801

psu (satellite-management)

IN THIS SECTION

- [Syntax](#) | 827
- [Hierarchy Level](#) | 828
- [Description](#) | 828
- [Required Privilege Level](#) | 828
- [Release Information](#) | 828

Syntax

```
psu {  
  redundancy {  
    n-plus-n;  }  
}
```

```
}
}
```

Hierarchy Level

```
[edit chassis satellite-management]
```

Description

Configure $N+N$ power supply redundancy for the satellite devices in a Junos Fusion.

The remaining statements are explained separately. See [CLI Explorer](#).

Required Privilege Level

interface—To view this statement in the configuration.

interface-control—To add this statement to the configuration.

Release Information

Statement introduced in Junos OS Release 16.1R1.

RELATED DOCUMENTATION

| [Understanding Power over Ethernet in a Junos Fusion](#) | 796

redundancy (satellite-management)

IN THIS SECTION

- [Syntax](#) | 829
- [Hierarchy Level](#) | 829
- [Description](#) | 829
- [Default](#) | 829

- Required Privilege Level | 829
- Release Information | 829

Syntax

```
redundancy {  
    n-plus-n;  
}
```

Hierarchy Level

```
[edit chassis satellite-management psu]
```

Description

Configure $N+M$ power supply redundancy for the satellite devices in a Junos Fusion.

The remaining statement is explained separately. See [CLI Explorer](#).

Default

$N+1$ power supply redundancy is configured on each satellite device by default.

Required Privilege Level

interface—To view this statement in the configuration.

interface-control—To add this statement to the configuration.

Release Information

Statement introduced in Junos OS Release 16.1R1.

RELATED DOCUMENTATION

| [Understanding Power over Ethernet in a Junos Fusion](#) | 796

Operational Commands for Power over Ethernet and Power Supply Management on Junos Fusion Enterprise

IN THIS CHAPTER

- [show chassis satellite power-budget-statistics | 831](#)
- [show poe controller | 835](#)
- [show poe interface | 839](#)

show chassis satellite power-budget-statistics

IN THIS SECTION

- [Syntax | 832](#)
- [Description | 832](#)
- [Options | 832](#)
- [Required Privilege Level | 832](#)
- [Output Fields | 832](#)
- [Sample Output | 833](#)
- [Release Information | 834](#)

Syntax

```
show chassis satellite power-budget-statistics
<slot-id slot-id-number>
```

Description

Display the power budget statistics of a satellite device or devices in a Junos Fusion.

Options

- none** Display power budget statistics for all satellite devices in the Junos Fusion.
- slot-id slot-id-number** Display power budget statistics for the specified satellite device only. The *slot-id-number* and the FPC ID are the same number in a Junos Fusion.

Required Privilege Level

view

Output Fields

[Table 43 on page 832](#) lists the output fields for the `show chassis satellite-management power-budget-statistics` command. Output fields are listed in the approximate order in which they appear.

Table 43: show chassis satellite-management power-budget-statistics Output Fields

Field Name	Field Description
FPC <i>n</i>	The FPC slot ID number in the Junos Fusion, where <i>n</i> is the FPC slot ID. The FPC slot ID and the satellite device number are the same thing in a Junos Fusion.
PSU <i>n</i> (<i>supply type</i>)	Capacity rating of the power supply and whether the power supply is currently operating (Online) or not (Offline). If a power supply is offline, the capacity is shown as 0 W.

Table 43: show chassis satellite-management power-budget-statistics Output Fields (Continued)

Field Name	Field Description
Total Power supplied by all Online PSUs	Total number of watts supplied by all currently operating power supplies for the satellite device.
Power Redundancy Configuration	Configured power redundancy setting, either $N+1$ or $N+N$.
Base power reserved	Total number of watts reserved for the satellite device.
Non-PoE power being consumed	The amount of power, in W , currently being consumed for functions other than PoE by the satellite device.
Total Power allocated for PoE	The total of the PoE power budgets allocated to the satellite device.
Total PoE power consumed	The amount of power that has been consumed by PoE by the satellite device.
Total PoE power remaining	The amount of available power remaining that can be used for PoE on the satellite device.

Sample Output

show chassis satellite power-budget-statistics

```

user@aggregation-device> show chassis satellite power-budget-statistics
fpc 100:
-----
PSU 0   (JPSU-550-DC-AFI  )      :   550 W   Online
PSU 1   (JPSU-550-DC-AFO  )      :   550 W   Online
Power redundancy configuration    :   N+N
Total power supplied by all online PSUs :   522 W
Base power reserved               :   175 W
Non-PoE power being consumed     :    82 W
Total power allocated for PoE    :   347 W

```

```

Total PoE power consumed           :    0 W
Total PoE power remaining          :   347 W
fpc 120:
-----
Power redundancy configuration      :    N+N
Total power supplied by all online PSUs :   170 W
Base power reserved                 :    0 W
Non-PoE power being consumed       :    0 W
fpc 128:
-----
Power redundancy configuration      :    N+N
Total power supplied by all online PSUs :    0 W
Base power reserved                 :    0 W
Non-PoE power being consumed       :    0 W
fpc 133:
-----
PSU 0                               ) :    0 W Offline
PSU 1 (JPSU-1100-AC-AFO )         :  1100 W Online
Power redundancy configuration      :    N+N
Total power supplied by all online PSUs :  1100 W
Base power reserved                 :   175 W
Non-PoE power being consumed       :    74 W
Total power allocated for PoE       :   925 W
Total PoE power consumed           :    0 W
Total PoE power remaining          :   925 W
fpc 240:
-----
Power redundancy configuration      :    N+N
Total power supplied by all online PSUs :    0 W
Base power reserved                 :    0 W
Non-PoE power being consumed       :    0 W

```

Release Information

Command introduced in Junos OS Release 16.1R1.

RELATED DOCUMENTATION

[Understanding Power over Ethernet in a Junos Fusion](#) | 796

show poe controller

IN THIS SECTION

- [Syntax | 835](#)
- [Description | 835](#)
- [Required Privilege Level | 835](#)
- [Output Fields | 835](#)
- [Sample Output | 837](#)
- [Release Information | 838](#)

Syntax

```
show poe controller
```

Description

Display configuration and status of the PoE controllers.

Required Privilege Level

view

Output Fields

[Table 44 on page 836](#) lists the output fields for the `show poe controller` command. Output fields are listed in the approximate order in which they appear.

Table 44: show poe controller Output Fields

Field Name	Field Description
Controller index	<p>PoE controller number:</p> <ul style="list-style-type: none"> • 0 for EX2200, EX3200, standalone EX3300, standalone EX4200 switches, standalone EX4300 switches, and ACX2000 routers. • Member ID for switches in an EX3300 Virtual Chassis, EX4200 Virtual Chassis, EX4300 Virtual Chassis, a mixed EX4200 and EX4500 Virtual Chassis. • Slot number for line cards with a PoE controller in an EX6200 or EX8200 switch.
Maximum power	The maximum PoE power consumption for the switch or line card. This is the total amount of power available to the PoE controller to allocate to the PoE ports.
Power consumption	Total amount of power being consumed by the PoE ports at the time the command is executed. This value, which represents actual power consumption, cannot exceed the value for Maximum power.
Guard Band	Amount of power that has been placed in reserve for power demand spikes and that cannot be allocated to a PoE interface.
Management	<p>Power management mode: class or static or high-power.</p> <p>NOTE: The mode high-power is available on only ACX2000 routers.</p>

Table 44: show poe controller Output Fields (*Continued*)

Field Name	Field Description
Status	<p>Status of the PoE controller:</p> <ul style="list-style-type: none"> • AF_ENHANCE—Controller supports enhanced PoE. The maximum power per PoE port is 18.6 W in static mode (15.4 W in class mode). • DEVICE FAIL—Software download to the controller has failed or the PoE controller is not initialized because of a hardware failure. • DOWNLOAD_INIT—Software download to the controller is in the initial phase. • AF_MODE—Controller supports standard IEEE 802.3af. The maximum power per PoE port is 15.4 W. • AT/AF COMBO—Controller supports a mix of standard IEEE 802.3af and IEEE 802.3at (PoE+) ports. The maximum power per port is 30 W for IEEE 802.3at (PoE+) ports and 15.4 W for the IEEE 802.3af ports. • AT_MODE—Controller supports IEEE 802.3at (PoE+). The maximum power per PoE port is 30 W. • SW_DOWNLOAD (r%)—Software download to the controller is in progress.
Lldp Priority	<p>Link Layer Discovery Protocol (LLDP) priority operating state. The state can be Enabled or Disabled.</p> <p>LLDP priority enables the PoE controller to assign interfaces the power priority provided by the connected powered device by using LLDP power negotiation rather than the power priority configured on the switch interface.</p>

Sample Output

show poe controller (EX3200 Switch)

```

user@switch> show poe controller
Controller  Maximum   Power      Guard   Management  Status   Lldp
index      power     consumption band      Management  Status   Priority
0          130.00W  81.20W    10W     Static      AF_ENHANCE Disabled

```

show poe controller (EX8200 Switch)

```

user@switch> show poe controller
Controller Maximum Power Guard Management Status Lldp
index power consumption band
0 792.00W 603.50W 0W Class AT/AF COMBO Disabled
4 915.00W 781.00W 0W Class AT/AF COMBO Disabled
7 915.00W 0.00W 0W Class AT/AF COMBO Disabled

```

show poe controller (Controller Software Upgrade in Progress)

```

user@switch> show poe controller

Controller Maximum Power Guard Management Status Lldp
index power consumption band
0 130.00W 0.00W 0W Static AF_ENHANCE Disabled
8** 130.00W 0.00W 0W Static SW_DOWNLOAD(10%) Disabled

**New PoE software upgrade available.
Use 'request system firmware upgrade poe fpc-slot <slot>'
This procedure will take around 10 minutes (recommended to be performed during maintenance)

```

show poe controller (ACX2000 Router)

```

user@host> show poe controller

Controller Maximum Power Guard Management Status Lldp
index power consumption band
0 130.0 W 14.2 W 0 W high-power UP

```

Release Information

Command introduced in Junos OS Release 9.0.

Command introduced in Junos OS Release 12.2 for ACX2000 routers.

Statement introduced in Junos OS Release 17.2R1 for a Junos Fusion Provider Edge.

RELATED DOCUMENTATION

[show poe interface | 839](#)

[request system firmware upgrade poe](#)

[Verifying PoE Configuration and Status \(CLI Procedure\)](#)

[Verifying PoE Configuration and Status for a Junos Fusion \(CLI Procedure\) | 806](#)

[Monitoring PoE Power Consumption \(CLI Procedure\)](#)

[Upgrading the PoE Controller Software](#)

show poe interface

IN THIS SECTION

- [Syntax | 839](#)
- [Description | 839](#)
- [Options | 840](#)
- [Required Privilege Level | 840](#)
- [Output Fields | 840](#)
- [Sample Output | 844](#)
- [Release Information | 847](#)

Syntax

```
show poe interface
<fpc-slot number>
<interface-name>
```

Description

Display the status of PoE interfaces.

Options

`none`—Display status of all PoE interfaces on the switch or router.

`fpc-slot number`—(Optional) (EX6200 or EX8200 switches only) Display the status of the PoE interfaces on the specified line card.

`interface-name`—(Optional) Display the status of a specific PoE interface on the switch.

Required Privilege Level

view

Output Fields

Table 45 on page 840 lists the output fields for the `show poe interface` command. Output fields are listed in the approximate order in which they appear.

Table 45: show poe interface Output Fields

Field Name (All Interfaces Output)	Field Name (Single Interface Output)	Field Description
Interface	PoE Interface	Interface name.
Admin status	Administrative status	Administrative state of the PoE interface: Enabled or Disabled . If the PoE interface is disabled, it can provide network connectivity, but it cannot provide power to connected devices.
Oper status	Operational status	Operational state of the PoE interface: <ul style="list-style-type: none"> • ON—The interface is currently supplying power to a powered device. • OFF—PoE is enabled on the interface, but the interface is not currently supplying power to a powered device. • FAULT—PoE interface is in the OFF state due to a fault condition. • Disabled—PoE is disabled on the interface.

Table 45: show poe interface Output Fields (Continued)

Field Name (All Interfaces Output)	Field Name (Single Interface Output)	Field Description
	Operational status detail	<p>Additional information for troubleshooting the operational state of the PoE interface:</p> <ul style="list-style-type: none"> • Admin up but disabled on hardware—The interface is disabled due to power budget unavailability. • Overload—Interface is in the fault condition. • IEEE PD Detected—The interface is providing power to the powered device. • Detection In Progress—Detection of the powered device is ongoing. • 4P Port that deliver only 2 Pair non IEEE—Signature failure on Alt-B, allowing power only on Alt-A (Non IEEE or Legacy PD). • 4P Port delivering 2P non IEEE—Non-IEEE PD was detected using 4P matrix in BT mode and power as 2Pair . • 4P Port delivering 4P non IEEE—Non-IEEE PD was detected using 4P matrix in BT mode and power as 4Pair. • 4P Port delivering 2P IEEE SSPD—802.3BT- SSPD was detected using 4P matrix and operate as 2P if requested class =< 4. • 4P Port delivering 4P IEEE SSPD—802.3BT- SSPD was detected using 4P matrix and operate as 4P if requested class > 4. • 4P Port delivering 2P IEEE DSPD in 1st phase—802.3BT- DSPD was detected using 4P matrix and operate as 2P due to 4pair candidate validation in two cycles. • 4P Port delivering 2P IEEE DSPD—802.3BT- DSPD was detected using 4P matrix and operate as 2P. • 4P Port delivering 4P IEEE DSPD—802.3BT- DSPD was detected using 4P matrix and operate as 4P. • Force Power BT 4P—Port matrix 4P and delivers power on both pair sets due to force power command.

Table 45: show poe interface Output Fields (*Continued*)

Field Name (All Interfaces Output)	Field Name (Single Interface Output)	Field Description
		<ul style="list-style-type: none"> • Force Power BT Error—Force power command was set, one of the port pair sets stop delivering power, from at least one reason out of various reasons (System related, Device related, port related or Pair set related). • Connection Check error—This error will be reported only in 4 pair port when invalid connection check signature was detected. In such case detection fail counter will be incremented. • Open—Port is not connected (Equivalent to Detection in Progress).
	FourPair status	<p>Status of four-pair PoE (PoE-4P), a Juniper Networks extension to the IEEE 802.3at standard, which can be enabled for high or ultra-high power delivery:</p> <ul style="list-style-type: none"> • Enabled—High or ultra-high power mode is enabled. • Disabled—High or ultra-high power mode is disabled. <p>See Enabling PoE on EX Series Switches (CLI Procedure) for information on how to enable four-pair PoE.</p>
Pair/Mode status		<p>Shows the mode of power delivery configured on the interface.</p> <ul style="list-style-type: none"> • 4P/AT—Interface is configured for high power mode. • 4P/POH—Interface is configured for ultra-high power mode. • DS/BT—Interface is configured for dual-signature powered devices. • SS/BT—Interface is configured for single-signature powered devices.

Table 45: show poe interface Output Fields (Continued)

Field Name (All Interfaces Output)	Field Name (Single Interface Output)	Field Description
Max power	Power limit on the interface	<p>Maximum power that can be provided by the interface. This is determined by the class of the powered device.</p> <p>For dual-signature devices, each pair set has its own class. The maximum power will be the total of the maximum power for the two classes: $\text{max power} = \text{class } x + \text{class } y$ for dual signature x/y. For example, a dual-signature device with a class value displayed as 5/5 has a maximum power of 90W, because class 5 has a maximum power of 45W.</p> <p>An (L) next to the value indicates that the value on the port was negotiated by LLDP.</p>
Priority	Priority	<p>Interface power priority: either High or Low.</p> <p>An (L) next to the value indicates that the value on the port was negotiated by LLDP.</p>
Power consumption	Power consumed	Amount of power being used by the interface at the time the command is executed.
Class	Class of power device	<p>IEEE PoE class of the powered device. Class 0 is the default class and is used when the class of the powered device is unknown. If no powered device is connected, this field contains not applicable.</p> <p>PoE-bt supports power devices with dual signatures. For dual-signature devices, the output value contains both the class values, e.g. 5/5. For single-signature devices, the output value is formatted as 5/-.</p>
	PoE Mode	IEEE PoE standard supported by the interface—either 802.3af, or 802.3at, ultra-poe, or 802.3bt.

Sample Output

show poe interface

```
user@switch> show poe interface
Interface Admin      Oper      Max      Priority Power      Class
           status      status    power
ge-0/0/0 Enabled    ON        15.4W    Low      7.9W       0
ge-0/0/1 Enabled    ON        15.4W    Low      3.2W       2
ge-0/0/2 Enabled    ON        15.4W    Low      3.2W       2
ge-0/0/3 Enabled    ON        15.4W    Low      3.2W       2
ge-0/0/4 Enabled    ON        15.4W    Low      3.2W       2
ge-0/0/5 Enabled    ON        15.4W    Low      3.2W       2
ge-0/0/6 Enabled    ON        15.4W    Low      3.2W       2
ge-0/0/7 Enabled    ON        15.4W    Low      3.2W       2
```

show poe interface (with LLDP negotiation)

```
user@switch> show poe interface
Interface Admin      Oper      Max      Priority Power      Class
           status      status    power
ge-0/0/0 Enabled    ON        17.5W(L) Low(L)    16.2W     4
ge-0/0/1 Enabled    ON        17.5W(L) Low(L)    16.0W     4
ge-0/0/2 Enabled    ON        17.5W(L) High(L)   16.0W     4
ge-0/0/3 Enabled    ON        17.5W(L) Low(L)    16.0W     4
ge-0/0/4 Enabled    ON        10.1W(L) Low(L)    10.0W     3
ge-0/0/5 Enabled    ON        3.5W(L)  High(L)   3.0W      2
(L) LLDP-negotiated value on the port.
```

show poe interface (specific interface)

```
user@switch> show poe interface ge-0/0/3
PoE interface status:
PoE interface           : ge-0/0/3
Administrative status   : Enabled
Operational status      : ON
Operational status detail : IEEE PD Detected
Power limit on the interface : 7.0W
```

```

Priority           : Low
Power consumed    : 5.3W
Class of power device : 2
PoE Mode         : 802.3af

```

show poe interface (specific FPC slot)

```
user@switch> show poe interface fpc-slot 3
```

Interface	Admin status	Oper status	Max power	Priority	Power consumption	Class
ge-3/0/0	Enabled	ON	30.0W	Low	20.3W	4
ge-3/0/1	Enabled	ON	30.0W	Low	17.8W	4
ge-3/0/2	Enabled	ON	30.0W	High	16.3W	4
ge-3/0/3	Enabled	ON	30.0W	High	16.2W	4
ge-3/0/4	Enabled	ON	30.0W	Low	25.9W	4
ge-3/0/5	Enabled	ON	30.0W	Low	10.1W	4
ge-3/0/6	Enabled	ON	30.0W	Low	16.2W	4
ge-3/0/7	Enabled	ON	30.0W	Low	6.4W	4
ge-3/0/8	Enabled	ON	30.0W	Low	5.2W	4
ge-3/0/9	Enabled	ON	30.0W	Low	5.2W	4
ge-3/0/10	Enabled	ON	30.0W	Low	21.5W	4
ge-3/0/11	Enabled	ON	30.0W	Low	21.7W	4
ge-3/0/12	Enabled	ON	15.4W	Low	9.4W	0
ge-3/0/13	Enabled	ON	15.4W	Low	9.4W	0
ge-3/0/14	Enabled	ON	15.4W	Low	9.4W	0
ge-3/0/15	Enabled	ON	15.4W	Low	9.4W	0
ge-3/0/16	Enabled	ON	15.4W	Low	9.4W	0
ge-3/0/17	Enabled	ON	15.4W	Low	9.4W	0
ge-3/0/18	Enabled	ON	15.4W	Low	9.4W	0
ge-3/0/19	Enabled	ON	15.4W	Low	9.4W	0
ge-3/0/20	Enabled	ON	15.4W	Low	9.4W	0
ge-3/0/21	Enabled	ON	15.4W	Low	9.4W	0
ge-3/0/22	Enabled	ON	15.4W	Low	9.4W	0
ge-3/0/23	Enabled	ON	15.4W	Low	9.4W	0
ge-3/0/24	Enabled	ON	15.4W	Low	9.4W	0
ge-3/0/25	Enabled	ON	15.4W	Low	9.4W	0
ge-3/0/26	Enabled	ON	15.4W	Low	9.4W	0
ge-3/0/27	Enabled	ON	15.4W	Low	9.4W	0
ge-3/0/28	Enabled	ON	15.4W	Low	7.0W	0
ge-3/0/29	Enabled	ON	15.4W	Low	2.2W	1
ge-3/0/30	Enabled	ON	15.4W	Low	2.2W	1

ge-3/0/31	Enabled	ON	15.4W	Low	2.2W	1
ge-3/0/32	Enabled	ON	15.4W	Low	2.0W	1
ge-3/0/33	Enabled	ON	15.4W	Low	2.0W	1
ge-3/0/34	Enabled	ON	15.4W	Low	2.2W	1
ge-3/0/35	Enabled	ON	15.4W	Low	2.2W	1
ge-3/0/36	Enabled	ON	15.4W	Low	2.2W	1
ge-3/0/37	Enabled	ON	15.4W	Low	2.2W	1
ge-3/0/38	Enabled	ON	15.4W	Low	2.2W	1
ge-3/0/39	Enabled	ON	15.4W	Low	2.2W	1

show poe interface (specific interface on ACX2000 Universal Metro Routers)

```

user@host> show poe interface ge-0/1/7
PoE interface status:
PoE interface           : ge-0/1/7
Administrative status   : Enabled
Operational status     : Powered-up
Power limit on the interface : 9.0 W
Priority                 : Low
Power consumed          : 14.2 W
Class of power device   : 4

```

show poe interface (PoE-bt mode)

```

user@switch> show poe interface
Interface  Admin    Oper    Pair/Mode  Max    Priority  Power      Class
           status  status  status     power                    consumption
ge-0/0/0   Enabled  ON      SS/BT      15.4W  Low       12.0W (L)  3/-
ge-0/0/1   Enabled  ON      4P/BT      60.0W  Low       55.0W      4/-
ge-0/0/2   Enabled  ON      4P/POH     90.0W  Low       81.0W      4/-
ge-0/0/3   Enabled  ON      SS/BT      90.0W  High      80.0W      8/-
ge-0/0/4   Enabled  ON      SS/BT      75.0W  Low       65.0W(L)  7/-
ge-0/0/5   Enabled  ON      SS/BT      30.0W  Low       27.0W      4/-
ge-0/0/6   Enabled  ON      SS/BT      15.4W  Low       13.0W      3/-
ge-0/0/7   Enabled  ON      SS/BT      60.0W  Low       49.0W      6/-
ge-0/0/8   Enabled  ON      DS/BT      90.0W  Low       78.0W      5/5
ge-0/0/9   Enabled  ON      DS/BT      75.0W  Low       68.0W(L)  5/4
ge-0/0/10  Enabled  ON      DS/BT      60.0W  Low       55.0W      4/4

```

show poe interface (PoE-bt mode: specific interface)

```
user@switch> show poe interface ge-0/0/3
PoE interface status:
PoE interface           : ge-0/0/3
Administrative status   : Enabled
Operational status     : ON
Four-pair status       : NA
Power limit on the interface : 90.0W
Priority                 : Low
Power consumed          : 78.0W
Class of power device   : 5/5
PoE Mode                : 802.3bt
```

Release Information

Command introduced in Junos OS Release 9.0.

Command introduced in Junos OS Release 12.2 for ACX2000 routers.

RELATED DOCUMENTATION

[show poe controller | 835](#)

[Enabling PoE on EX Series Switches \(CLI Procedure\)](#)

Link Aggregation and LACP on Junos Fusion Enterprise

IN THIS CHAPTER

- [Configuring Link Aggregation on Satellite Devices in a Junos Fusion Enterprise | 848](#)
- [Configuring an Aggregated Ethernet Interface | 850](#)
- [Configuring Aggregated Ethernet LACP | 851](#)

Configuring Link Aggregation on Satellite Devices in a Junos Fusion Enterprise

Link aggregation, as defined by IEEE 802.3ad, allows users to bundle multiple Ethernet interfaces into a single logical interface. An aggregated Ethernet interface, also known as a link aggregation group (LAG), balances traffic across its member links within the aggregated Ethernet bundle and effectively increases the uplink bandwidth. Aggregated Ethernet interfaces also increase high availability, because an aggregated Ethernet interface is composed of multiple member links that can continue to carry traffic when one member link fails.

In a Junos Fusion Enterprise, you can configure aggregated Ethernet interfaces using extended port member links to increase uplink bandwidth and high availability for endpoint devices connected to a satellite device. These aggregated Ethernet interfaces can be configured to use Link Aggregation Control Protocol (LACP).

LACP is a subcomponent of the IEEE 802.3ad standard that simplifies management of LAGs. LACP automates the addition and deletion of individual links to the LAG without user intervention, and can also prevent communication failures by detecting misconfigurations within a LAG. LACP-enabled devices exchange LACP protocol data units (PDUs) to monitor links between LAG peers. You can configure Ethernet links to actively transmit LACP PDUs, or you can configure the links to passively transmit them, sending out LACP PDUs only when they receive them from another link.

LAG and LACP configuration on extended ports in a Junos Fusion Enterprise is identical for a standalone EX Series switch. The following guidelines apply to link aggregation in a Junos Fusion Enterprise:

- The member links must be located on the same satellite device.
- Up to 1000 LAGs are supported, with up to 16 members per LAG.
- LAGs are numbered from ae0 through ae4091.
- The LAG must be configured on both sides of the link.
- The interfaces on either side of the link must be set to the same speed and be in full-duplex mode.

To configure link aggregation in a Junos Fusion Enterprise:

1. Configure the maximum number of aggregated Ethernet interfaces:

```
[edit]
user@aggregation-device# set chassis aggregated-devices ethernet device-count number
```

2. Create and name the aggregated Ethernet interface:

```
[edit]
user@aggregation-device# set interfaces aex
```

NOTE: Specify the aggregated Ethernet interface name as *aex*, where *x* is the interface instance number. The instance number can be from 0 through 4091.

3. Assign interfaces to the aggregated Ethernet interface:

```
[edit]
user@aggregation-device# set interfaces interface-name ether-options 802.3ad aex
```

For example:

```
[edit]
user@aggregation-device# set interfaces xe-100/0/12 ether-options 802.3ad ae0
user@aggregation-device# set interfaces xe-100/0/13 ether-options 802.3ad ae0
user@aggregation-device# set interfaces xe-100/0/46 ether-options 802.3ad ae1
```

4. Enable LACP for the aggregated Ethernet interface:

```
[edit]
user@aggregation-device# set interfaces aex aggregated-ether-options lacp
```

For information on configuring LACP parameters, see "[Configuring Aggregated Ethernet LACP](#)" on [page 851](#).

RELATED DOCUMENTATION

[Configuring an Aggregated Ethernet Interface | 850](#)

[Configuring Aggregated Ethernet LACP | 851](#)

Configuring an Aggregated Ethernet Interface

You can associate a physical interface with an aggregated Ethernet interface.

To configure an aggregated Ethernet interface:

1. Specify that you want to configure the link aggregation group interface.

```
user@host# edit interfaces interface-name
```

2. Configure the aggregated Ethernet interface.

```
[edit interfaces interface-name]
user@host# set ether-options 802.3ad aex
```

You specify the interface instance number x to complete the link association; You must also include a statement defining aex at the [edit interfaces] hierarchy level. You can optionally specify other physical properties that apply specifically to the aggregated Ethernet interfaces; for details, see [Ethernet Interfaces Overview](#).

NOTE: In general, aggregated Ethernet bundles support the features available on all supported interfaces that can become a member link within the bundle. As an exception, Gigabit Ethernet

IQ features and some newer Gigabit Ethernet features are not supported in aggregated Ethernet bundles.

Gigabit Ethernet IQ and SFP interfaces can be member links, but IQ- and SFP-specific features are not supported on the aggregated Ethernet bundle even if all the member links individually support those features.

You need to configure the correct link speed for the aggregated Ethernet interface to eliminate any warning message.

NOTE: Before you commit an aggregated Ethernet configuration, ensure that link mode is not configured on any member interface of the aggregated Ethernet bundle; otherwise, the configuration commit check fails.

RELATED DOCUMENTATION

| [Aggregated Ethernet Interfaces Overview](#)

Configuring Aggregated Ethernet LACP

IN THIS SECTION

- [Configuring the LACP Interval | 853](#)
- [Configuring LACP Link Protection | 854](#)
- [Configuring LACP System Priority | 855](#)
- [Configuring LACP System Identifier | 855](#)
- [Configuring LACP administrative Key | 856](#)
- [Configuring LACP Port Priority | 856](#)
- [Tracing LACP Operations | 857](#)
- [LACP Limitations | 857](#)
- [Example: Configuring Aggregated Ethernet LACP | 857](#)

For aggregated Ethernet interfaces, you can configure the Link Aggregation Control Protocol (LACP). LACP is one method of bundling several physical interfaces to form one logical interface. You can configure both VLAN-tagged and untagged aggregated Ethernet with or without LACP enabled.

For Multichassis Link Aggregation (MC-LAG), you must specify the `system-id` and `admin key`. MC-LAG peers use the same `system-id` while sending the LACP messages. The `system-id` can be configured on the MC-LAG network device and synchronized between peers for validation.

LACP exchanges are made between actors and partners. An actor is the local interface in an LACP exchange. A partner is the remote interface in an LACP exchange.

LACP is defined in IEEE 802.3ad, *Aggregation of Multiple Link Segments*.

LACP was designed to achieve the following:

- Automatic addition and deletion of individual links to the aggregate bundle without user intervention
- Link monitoring to check whether both ends of the bundle are connected to the correct group

The Junos OS implementation of LACP provides link monitoring but not automatic addition and deletion of links.

The LACP mode can be active or passive. If the actor and partner are both in passive mode, they do not exchange LACP packets, which results in the aggregated Ethernet links not coming up. If either the actor or partner is active, they do exchange LACP packets. By default, LACP is turned off on aggregated Ethernet interfaces. If LACP is configured, it is in passive mode by default. To initiate transmission of LACP packets and response to LACP packets, you must configure LACP in active mode.

To enable LACP active mode, include the `lacp` statement at the `[edit interfaces interface-name aggregated-ether-options]` hierarchy level, and specify the `active` option:

```
[edit interfaces interface-name aggregated-ether-options]
lacp {
  active;
}
```

NOTE: The LACP process exists in the system only if you configure the system in either active or passive LACP mode.

To restore the default behavior, include the `lACP` statement at the `[edit interfaces interface-name aggregated-ether-options]` hierarchy level, and specify the `passive` option:

```
[edit interfaces interface-name aggregated-ether-options]
lACP {
    passive;
}
```

Starting with Junos OS release 12.2, you can also configure LACP to override the IEEE 802.3ad standard and to allow the standby link always to receive traffic. Overriding the default behavior facilitates subsecond failover.

To override the IEEE 802.3ad standard and facilitate subsecond failover, include the `fast-failover` statement at the `[edit interfaces interface-name aggregated-ether-options lACP]` hierarchy level.

For more information, see the following sections:

Configuring the LACP Interval

By default, the actor and partner send LACP packets every second. You can configure the interval at which the interfaces send LACP packets by including the `periodic` statement at the `[edit interfaces interface-name aggregated-ether-options lACP]` hierarchy level:

```
[edit interfaces interface-name aggregated-ether-options lACP]
periodic interval;
```

The interval can be fast (every second) or slow (every 30 seconds). You can configure different periodic rates on active and passive interfaces. When you configure the active and passive interfaces at different rates, the transmitter honors the receiver's rate.

NOTE: Source address filtering does not work when LACP is enabled.

Percentage policers are not supported on aggregated Ethernet interfaces with the CCC protocol family configured. For more information about percentage policers, see the [Routing Policies, Firewall Filters, and Traffic Policers User Guide](#).

Generally, LACP is supported on all untagged aggregated Ethernet interfaces. For more information, see [Configuring Untagged Aggregated Ethernet Interfaces](#).

Configuring LACP Link Protection

NOTE: When using LACP link protection, you can configure only two member links to an aggregated Ethernet interface: one active and one standby.

To force active and standby links within an aggregated Ethernet, you can configure LACP link protection and system priority at the aggregated Ethernet interface level using the `link-protection` and `system-priority` statements. Configuring values at this level results in only the configured interfaces using the defined configuration. LACP interface configuration also enables you to override global (chassis) LACP settings.

LACP link protection also uses port priority. You can configure port priority at the Ethernet interface `[ether-options]` hierarchy level using the `port-priority` statement. If you choose not to configure port priority, LACP link protection uses the default value for port priority (127).

NOTE: LACP link protection supports per-unit scheduling configuration on aggregated Ethernet interfaces.

To enable LACP link protection for an aggregated Ethernet interfaces, use the `link-protection` statement at the `[edit interfaces aeX aggregated-ether-options lacp]` hierarchy level:

```
[edit interfaces aeX aggregated-ether-options lacp]
link-protection;
  disable;
  revertive;
  non-revertive;
}
```

By default, LACP link protection reverts to a higher-priority (lower-numbered) link when that higher-priority link becomes operational or a link is added to the aggregator that is determined to be higher in priority. However, you can suppress link calculation by adding the `non-revertive` statement to the LACP link protection configuration. In nonrevertive mode, once a link is active and collecting and distributing packets, the subsequent addition of a higher-priority (better) link does not result in a switch and the current link remains active.

If LACP link protection is configured to be nonrevertive at the global (`[edit chassis]` hierarchy) level, you can add the `revertive` statement to the LACP link protection configuration to override the nonrevertive setting for the interface. In revertive mode, the addition of a higher-priority link to the aggregator results in LACP performing a priority recalculation and switching from the current active link to the new active link.



CAUTION: If both ends of an aggregator have LACP link protection enabled, make sure to configure both ends of the aggregator to use the same mode. Mismatching LACP link protection modes can result in lost traffic.

We strongly recommend you to use LACP on both ends of the aggregator, when you connect an aggregated Ethernet interface with two member interfaces to any other vendor device. Otherwise, the vendor device (say a Layer 2 switch, or a router), will not be able to manage the traffic coming from the two link aggregated Ethernet bundle. As a result, you might observe the vendor device sending back the traffic to the backup member link of the aggregated Ethernet interface.

Currently, MX-MPC2-3D, MX-MPC2-3D-Q, MX-MPC2-3D-EQ, MX-MPC1-3D, MX-MPC1-3D-Q, and MPC-3D-16XGE-SFPP do not drop traffic coming back to the backup link, whereas DPCE-R-Q-20GE-2XGE, DPCE-R-Q-20GE-SFP, DPCE-R-Q-40GE-SFP, DPCE-R-Q-4XGE-XFP, DPCE-X-Q-40GE-SFP, and DPCE-X-Q-4XGE-XFP drop traffic coming to the backup link.

Configuring LACP System Priority

To configure LACP system priority for aggregated Ethernet interfaces on the interface, use the `system-priority` statement at the `[edit interfaces aeX aggregated-ether-options lacp]` hierarchy level:

```
[edit interfaces aeX aggregated-ether-options lacp]
system-priority;
```

The system priority is a 2-octet binary value that is part of the LACP system ID. The LACP system ID consists of the system priority as the two most-significant octets and the interface MAC address as the six least-significant octets. The system with the numerically lower value for system priority has the higher priority. By default, system priority is 127, with a range of 0 to 65,535.

Configuring LACP System Identifier

To configure the LACP system identifier for aggregated Ethernet interfaces, use the `system-id` statement at the `[edit interfaces aeX aggregated-ether-options lacp]` hierarchy level:

```
[edit interfaces aeX aggregated-ether-options lacp]
system-id system-id;
```

The user-defined system identifier in LACP enables two ports from two separate devices to act as though they were part of the same aggregate group.

The system identifier is a 48-bit (6-byte) globally unique field. It is used in combination with a 16-bit system-priority value, which results in a unique LACP system identifier.

Configuring LACP administrative Key

To configure an administrative key for LACP, include the `admin-key number` statement at the `edit interfaces ae x aggregated-ether-options lacp` hierarchy level:

```
[edit interfaces ae x aggregated-ether-options-lacp]
admin-key number;
```

NOTE: You must configure MC-LAG to configure the `admin-key` statement. For more information about MC-LAG, see [Configuring Multichassis Link Aggregation on MX Series Routers](#).

Configuring LACP Port Priority

To configure LACP port priority for aggregated Ethernet interfaces, use the `port-priority` statement at the `[edit interfaces interface-name ether-options 802.3ad aeX lacp]` or `[edit interfaces interface-name ether-options 802.3ad aeX lacp]` hierarchy levels:

```
[edit interfaces interface-name ether-options 802.3ad aeX lacp]
port-priority priority;
```

The port priority is a 2-octet field that is part of the LACP port ID. The LACP port ID consists of the port priority as the two most-significant octets and the port number as the two least-significant octets. The system with the numerically lower value for port priority has the higher priority. By default, port priority is 127, with a range of 0 to 65,535.

Port aggregation selection is made by each system based on the highest port priority and are assigned by the system with the highest priority. Ports are selected and assigned starting with the highest priority port of the highest priority system and working down in priority from there.

NOTE: Port aggregation selection (discussed above) is performed for the active link when LACP link protection is enabled. Without LACP link protection, port priority is not used in port aggregation selection.

Tracing LACP Operations

To trace the operations of the LACP process, include the `traceoptions` statement at the `[edit protocols lacp]` hierarchy level:

```
[edit protocols lacp]
traceoptions {
  file <filename> <files number> <size size> <world-readable | no-world-readable>;
  flag <flag>;
  no-remote-trace;
}
```

You can specify the following flags in the `protocols lacp traceoptions` statement:

- `all`—All LACP tracing operations
- `configuration`—Configuration code
- `packet`—Packets sent and received
- `process`—LACP process events
- `protocol`—LACP protocol state machine
- `routing-socket`—Routing socket events
- `startup`—Process startup events

LACP Limitations

LACP can link together multiple different physical interfaces, but only features that are supported across all of the linked devices will be supported in the resulting link aggregation group (LAG) bundle. For example, different PICs can support a different number of forwarding classes. If you use link aggregation to link together the ports of a PIC that supports up to 16 forwarding classes with a PIC that supports up to 8 forwarding classes, the resulting LAG bundle will only support up to 8 forwarding classes. Similarly, linking together a PIC that supports WRED with a PIC that does not support it will result in a LAG bundle that does not support WRED.

Example: Configuring Aggregated Ethernet LACP

Configure aggregated Ethernet LACP over a VLAN-tagged interface:

LACP with VLAN-Tagged Aggregated Ethernet

```
[edit interfaces]
ge-1/1/1 {
  ether-options {
    802.3ad ae0;
  }
}
ae0 {
  aggregated-ether-options {
    lACP {
      active;
    }
  }
  vlan-tagging;
  unit 0 {
    vlan-id 100;
    family inet {
      address 10.1.1.2/24 {
        vrrp-group 0 {
          virtual-address 10.1.1.4;
          priority 200;
        }
      }
    }
  }
}
```

Configure aggregated Ethernet LACP over an untagged interface:

LACP with Untagged Aggregated Ethernet

```
[edit interfaces]
ge-1/1/1 {
  ether-options {
    802.3ad ae0;
  }
}
ae0 {
  aggregated-ether-options {
    lACP {
      active;
    }
  }
}
```

```
    }  
  }  
  unit 0 {  
    family inet {  
      address 10.1.1.2/24 {  
        vrrp-group 0 {  
          virtual-address 10.1.1.4;  
          priority 200;  
        }  
      }  
    }  
  }  
}
```

RELATED DOCUMENTATION

[lacp](#)

[link-protection](#)

[traceoptions](#)

SNMP MIB Support on Junos Fusion Enterprise

IN THIS CHAPTER

- Chassis MIB Support (Junos Fusion) | 860

Chassis MIB Support (Junos Fusion)

The Chassis MIB has been enhanced to enable satellite devices to be represented in the chassis MIB. Satellite devices are represented as FPCs/slots (100, 101, 102,...) in the aggregation device. The support is enabled using a separate range of container indices (CIDX), which allows the SNMP process to redirect relevant SNMP requests to the satellite device management process.

The CIDX for representing satellite device hardware components in Junos Fusion are offset by 100 from indices for hardware components on Junos devices; for example a regular CIDX 2 (Power Supply) is 102 for the power supply of the satellite device. Using these indices you can distinguish the satellite device hardware from the aggregate device. The L1 index for satellite device entries refers to their FPC slot identifiers. As per the chassis MIB convention, identifiers are 1-based. For example, satellite device 100 will have an L1 index of 101, satellite device 101 will have an L1 index of 102, and so on.

[Table 46 on page 860](#) shows the CIDXs used for satellite devices.

Table 46: CIDX's for Satellite Devices

CIDX	Component Type
102	Power Supply
104	Fan
107	FPC

Table 46: CIDX's for Satellite Devices (Continued)

CIDX	Component Type
108	PIC

The following tables have been enhanced to include object IDs for satellite devices:

- jnxContainersTable
- jnxContentsTable
- jnxFilledTable
- jnxOperatingTable
- jnxFRUTable

Examples of new object IDs in the jnxContainersTable:

```

jnxContainersType.102 = jnxSatelliteDeviceSlotPower.0
jnxContainersType.104 = jnxSatelliteDeviceSlotFan.0
jnxContainersType.107 = jnxSatelliteDeviceSlotFPC.0
jnxContainersType.108 = jnxSatelliteDeviceMediaCardSpacePIC.0
...
...
jnxContainersDescr.102 = SD PEM slot
jnxContainersDescr.104 = SD FAN slot
jnxContainersDescr.107 = SD FPC slot
jnxContainersDescr.108 = SD PIC slot

```

Examples of new object IDs in the jnxContentsTable:

```

jnxContentsType.102.102.1.0 = jnxSatelliteDeviceSlotPower
jnxContentsType.102.102.2.0 = jnxSatelliteDeviceSlotPower
jnxContentsType.104.102.1.0 = jnxSatelliteDeviceSlotFan
jnxContentsType.104.102.2.0 = jnxSatelliteDeviceSlotFan
jnxContentsType.104.102.3.0 = jnxSatelliteDeviceSlotFan
jnxContentsType.104.102.4.0 = jnxSatelliteDeviceSlotFan
jnxContentsType.104.102.5.0 = jnxSatelliteDeviceSlotFan
jnxContentsType.107.102.0.0 = jnxSatelliteDeviceSlotFPC
jnxContentsType.108.102.1.0 = jnxSatelliteDeviceMediaCardSpacePIC

```



```

...
jnxContentsDescr.102.102.1.0 = SD101 PEM 0
jnxContentsDescr.102.102.2.0 = SD101 PEM 1
jnxContentsDescr.104.102.1.0 = SD101 Fan Tray 0
jnxContentsDescr.104.102.2.0 = SD101 Fan Tray 1
jnxContentsDescr.104.102.3.0 = SD101 Fan Tray 2
jnxContentsDescr.104.102.4.0 = SD101 Fan Tray 3
jnxContentsDescr.104.102.5.0 = SD101 Fan Tray 4
jnxContentsDescr.107.102.0.0 = SD101 FPC: QFX5100-48S-6Q @ 101/*/*
jnxContentsDescr.108.102.1.0 = SD101 PIC: 48x10G-6x40G @ 101/0/*

```

The following SNMP traps are generated for Satellite Devices, which are also logged as syslog messages:

- Satellite Device (as FPC) add (online) or remove
- Satellite Device Fan add (online) or remove
- Satellite Device PSU add (online) or remove
- Satellite Device PIC add (online) or remove
- Satellite Device FAN failure or status
- Satellite Device PSU failure or status

[Table 47 on page 862](#) shows the SNMP traps that can be generated for satellite devices.

Table 47: SNMP Traps Generated for Satellite Devices

Trap	Condition
jnxFruRemoval	Sent when the specified FRU (FAN/PSU) has been removed from the chassis, or the satellite device has been removed from the aggregation device's database
jnxFruInsertion	Sent when the specified FRU (FAN/PSU) has been inserted into the satellite device
jnxFruPowerOff	Sent when the specified FRU (FAN/PSU) has been powered off in the satellite device
jnxFruPowerOn	Sent when the specified FRU (FAN/PSU) has been powered on in the satellite device

Table 47: SNMP Traps Generated for Satellite Devices (Continued)

Trap	Condition
jnxFruFailed	Sent when the specified FRU (FAN/PSU) has failed in the satellite device. Typically, this is due to the FRU not powering up or being unable to load software. FRU replacement might be required
jnxFruOK	
jnxFruOffline	Sent when FPC's new reported state is not online or PSU/FAN/PIC is not present due to satellite device removal
jnxFruOnline	Sent when specified FRU (FPC,PIC,PSU,FAN) gets added in the aggregation device database
jnxFruCheck	Sent when the specified FRU (FAN/PSU) has encountered operational errors

Given below are examples of the system log messages generated:

```
messages:Apr 15 21:28:36 card spmd[6706]: SPMD_SNMP_TRAP10: SNMP trap generated: Fru Offline
(jnxFruContentsIndex 102, jnxFruL1Index 109, jnxFruL2Index 1, jnxFruL3Index 0, jnxFruName SD108
PEM 0, jnxFruType 7, jnxFruSlot 0, jnxFruOfflineReason 1, jnxFruLastPowerOff 0,
jnxFruLastPowerOn 0)
```

```
messages:Apr 15 21:28:36 card spmd[6706]: SPMD_SNMP_TRAP10: SNMP trap generated: Fru Offline
(jnxFruContentsIndex 104, jnxFruL1Index 109, jnxFruL2Index 1, jnxFruL3Index 1, jnxFruName SD108
Fan Tray 0, jnxFruType 13, jnxFruSlot 0, jnxFruOfflineReason 1, jnxFruLastPowerOff 0,
jnxFruLastPowerOn 0)
```

```
messages:Apr 15 21:28:57 card spmd[8847]: SPMD_SNMP_TRAP7: SNMP trap generated: Fru Online
(jnxFruContentsIndex 107, jnxFruL1Index 103, jnxFruL2Index 0, jnxFruL3Index 0, jnxFruName SD102
FPC: @ 102/*/*, jnxFruType 3, jnxFruSlot 102)
```

```
messages:Apr 15 21:28:36 card spmd[6706]: SPMD_SNMP_TRAP10: SNMP trap generated: Fru Offline
(jnxFruContentsIndex 108, jnxFruL1Index 109, jnxFruL2Index 1, jnxFruL3Index 0, jnxFruName SD108
```

```
PIC: 48x 10/100/1000 Base-T @ 108/0/*, jnxFruType 11, jnxFruSlot 0, jnxFruOfflineReason 1,  
jnxFruLastPowerOff 0, jnxFruLastPowerOn 0)
```

Media Access Control Security (MACsec) on Junos Fusion Enterprise

IN THIS CHAPTER

- [Understanding Media Access Control Security on a Junos Fusion Enterprise | 865](#)

Understanding Media Access Control Security on a Junos Fusion Enterprise

IN THIS SECTION

- [MacSec Overview | 865](#)
- [Enabling MACsec in a Junos Fusion Enterprise | 866](#)

Media Access Control Security (MACsec) is widely used in campus deployments to secure network traffic between endpoints and access switches. You can enable MACsec on extended ports in a Junos Fusion Enterprise topology to provide secure communication between the satellite device and connected hosts.

MacSec Overview

MACsec is an 802.1AE IEEE industry-standard security technology that provides secure communication on Ethernet links between directly-connected nodes. MACsec is capable of identifying and preventing most security threats, including denial of service, intrusion, man-in-the-middle, masquerading, passive wiretapping, and playback attacks. MACsec provides point-to-point integrity and can be used in combination with other security solutions, such as IP Security (IPsec) and Secure Sockets Layer (SSL), to provide end-to-end network security.

See [Understanding Media Access Control Security \(MACsec\)](#) for a detailed overview of MACsec.

Enabling MACsec in a Junos Fusion Enterprise

To enable MACsec on a link connecting an endpoint device—such as a server, phone, or personal computer—to an extended port in a Junos Fusion Enterprise, the endpoint device must support MACsec and must be running client software that allows it to enable a MACsec-secured connection. A secure association using dynamic secure association security mode (dynamic SAK) must be configured on the extended port that connects to the host. The secure association keys are retrieved from the RADIUS server as part of the 802.1X authentication process. The keys are exchanged between the MACsec peers to create a secure connection.

MacSec configuration in Junos Fusion is done on the aggregated device and is identical for a standalone EX Series switch. See [Configuring MACsec on EX, QFX and SRX Devices](#).

NOTE: When MACsec is enabled in a Junos Fusion with dual aggregation devices, the exchange of EAPoL packets that takes place during the 802.1X authentication session is limited to one aggregation device (AD). The MKA protocol is triggered only on that (AD), and the keys generated by MKA are not synced across the ADs. If the AD on which the keys are generated fails, then the MACsec sessions must be re-authenticated using the other AD.

RELATED DOCUMENTATION

| [Configuring MACsec on EX, QFX and SRX Devices](#)

Class of Service on Junos Fusion Enterprise

IN THIS CHAPTER

- Understanding CoS in Junos Fusion Enterprise | 867
- Configuring CoS in Junos Fusion Enterprise | 872

Understanding CoS in Junos Fusion Enterprise

IN THIS SECTION

- Overview of CoS on Different Types of Ports in Junos Fusion | 869
- CoS on Extended Ports and Uplink Ports in Junos Fusion | 870
- CoS on Cascade Ports in Junos Fusion | 871

Junos Fusion provides a method of significantly expanding the number of available network interfaces on an *aggregation device* by allowing the aggregation device to add interfaces through interconnections with *satellite devices*. The entire system—the interconnected aggregation device and satellite devices—is called Junos Fusion. Junos Fusion simplifies network administration by appearing in the network topology as a single device, and the single device is managed from a single IP address.

See [Figure 11 on page 868](#) and [Figure 12 on page 868](#) for illustrations of the Junos Fusion Enterprise topology.

Figure 11: Basic Junos Fusion Topology

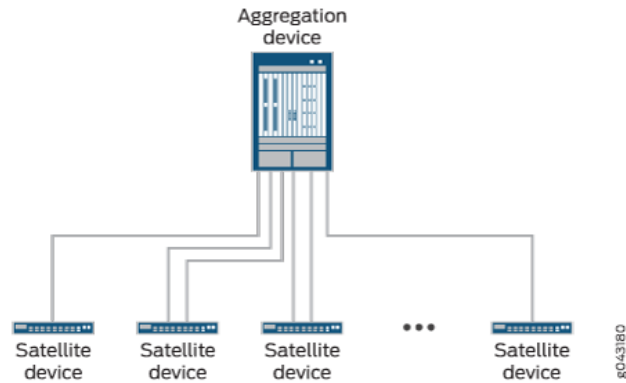
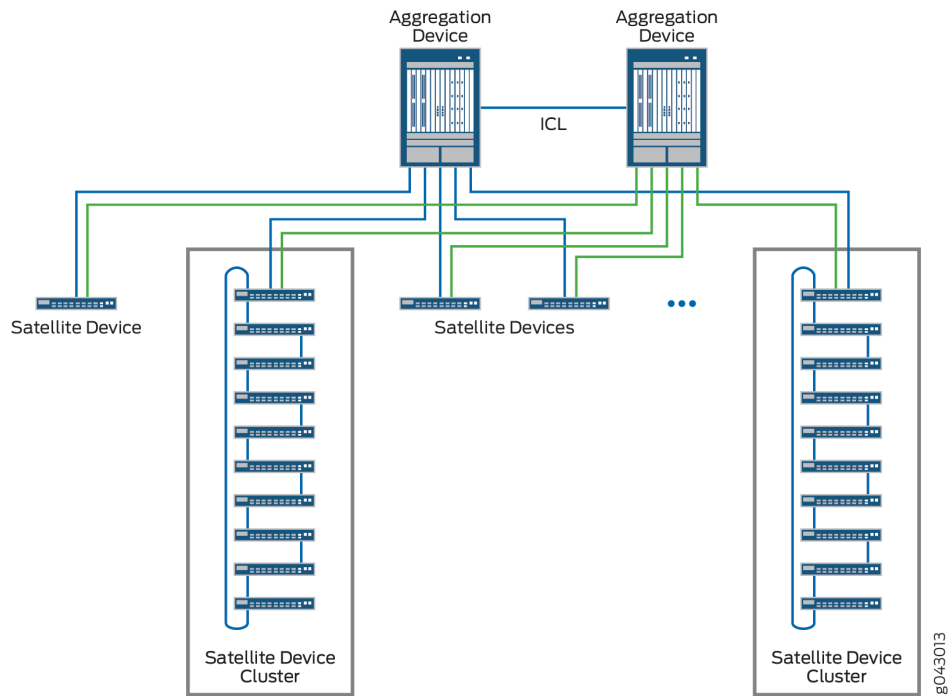

Figure 12: Junos Fusion Topology with Dual Aggregation Devices and Satellite Device Clusters



For Junos Fusion Enterprise, an aggregation device is an EX9200 switch that is running Junos OS Release 16.1R1 or later. Beginning with Junos OS Release 17.1R1, Junos Fusion Enterprise supports CoS. CoS configuration is the same on Junos Fusion Enterprise regardless of the selected architecture - single or dual aggregation devices, single or cluster satellite devices.

This topic describes class of service (CoS) on the different types of ports in Junos Fusion.

This topic covers:

Overview of CoS on Different Types of Ports in Junos Fusion

Figure 13 on page 869 provides an overview of packet flow through Junos Fusion and how CoS features are applied at the different ports.

Figure 13: Junos Fusion CoS Feature Application

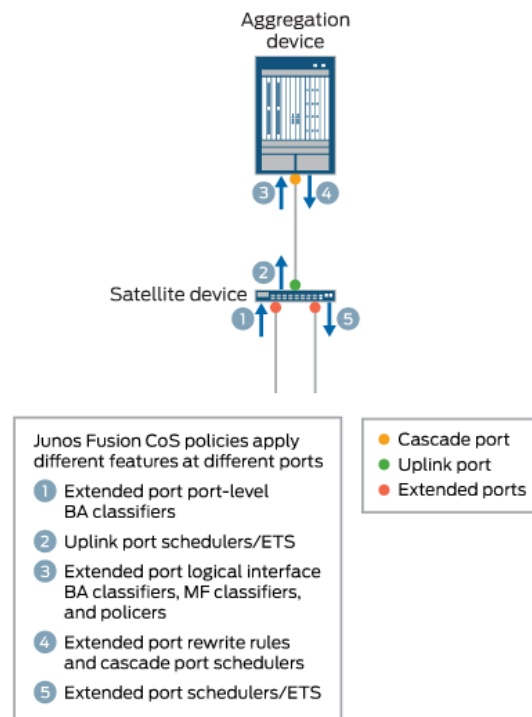

All configuration for CoS policies for Junos Fusion is done on the aggregation device. For CoS policies that you define for extended ports, however, different portions of that policy are applied at different points in a packet's path through Junos Fusion. From Figure 13 on page 869:

1. As a packet enters an extended port, any port-level (physical interface-level) behavior aggregate (BA) classifier you define for that port is applied to derive a forwarding class and packet loss priority.
2. As that packet exits the uplink port, you can apply schedulers or enhanced transmission selection (ETS) based on the port-level BA classifier assigned at the ingress extended port.
3. As the packet enters the aggregation device at the cascade port, any multifield classifiers, policers, or logical interface-level BA classifiers you define for the ingress extended port are applied.

4. As the packet exits the aggregation device at the cascade port, any rewrite rules you define for the egress extended port, as well as any schedulers you define for the cascade port, are applied. Also, the forwarding class determined in the previous step is carried in the 801.2BR header to the satellite device and used to select the output queue at the egress extended port.
5. Finally, as the packet exits an extended port, any schedulers or ETS you define for that port are applied based on the forwarding class determined by the multifield classifiers, policers, or logical interface-level BA classifiers defined for the ingress extended port.

The following sections provide further information about implementing CoS on each port type in Junos Fusion.

CoS on Extended Ports and Uplink Ports in Junos Fusion

All class of service (CoS) scheduling policies for extended ports and uplink ports on the satellite devices are provisioned on the EX9200 aggregation device. Similarly, standard Junos OS CoS commands are issued on the EX9200 aggregation device for retrieving extended port and uplink port CoS states and queue statistics. The EX9200 aggregation device supports configuring the following CoS features for each extended port and uplink port on each satellite device:

- Behavior aggregate classifiers
- Multifield classifiers
- Input and output policers
- Forwarding classes
- Traffic control profiles
- Schedulers and scheduler maps
- Egress rewrite rules

NOTE: Configuring CoS policies on *satellite devices* (on both extended and uplink ports) has the following restrictions:

- IP precedence classifiers are not supported. DSCP classifiers are supported, however.
- Interpolated drop profiles are not supported.
- The `transmit-rate` option is supported for schedulers. However, the `remainder`, `rate-limit`, and `exact` options are not supported under `transmit-rate`.

While CoS features for satellite device ports are configured on the aggregation device, the actual classification, queueing, and scheduling is performed on the satellite devices. Information on actual traffic shaping is not passed back to the aggregation device. Logical interface statistics for the **show interfaces** command are collected on the aggregate device and do not include shaping rate data. For actual traffic statistics gathered on satellite device interfaces, use the statistics for the physical interface and not the logical interface.

NOTE: CoS statistics are not supported on extended ports.

CoS on Cascade Ports in Junos Fusion

When a cascade port is created, two logical interfaces are automatically created:

- One in-band management logical interface (assigned unit 32769) for traffic that only flows between the aggregation device and the satellite devices, such as keepalives, for provisioning information, and for software updates.
- One for data logical interface (assigned unit 32770) for regular traffic that flows into and out of Junos Fusion.

Per-unit scheduling is automatically enabled on the cascade port to support multiple queues on each of the logical interfaces.

NOTE: All cascade ports must be configured on Modular Port Concentrators (MPCs) that support per-unit scheduling.

50 Mbps of bandwidth is reserved for the management logical interface. The remaining bandwidth is available to the data logical interface. A shaping rate of 10 percent is also applied to the management logical interface, which means it can use up to 10 percent of the full interface bandwidth, if available.

The default scheduling policy is applied to the data logical interface. This reserves 95 percent of the available bandwidth and buffer space for the best effort forwarding class (mapped to queue 0) and 5 percent for the network control forwarding class (mapped to queue 3). You can create custom forwarding classes and schedulers by applying a custom scheduler map to this logical interface.

Release History Table

Release	Description
17.1R1	Beginning with Junos OS Release 17.1R1, Junos Fusion Enterprise supports CoS.

RELATED DOCUMENTATION

[Junos Fusion Enterprise Overview | 3](#)

[Understanding Junos Fusion Enterprise Components | 6](#)

[Configuring CoS in Junos Fusion Enterprise | 872](#)

Configuring CoS in Junos Fusion Enterprise

IN THIS SECTION

- [Configuring Behavior Aggregate Classifiers on Satellite Device Extended Ports | 872](#)
- [Configuring Rewrite Rules on Satellite Device Extended Ports | 874](#)
- [Changing the Default Scheduling Policy on an Aggregated Device Cascade Port | 875](#)

Junos Fusion significantly expands the number of available network interfaces on an *aggregation device* by allowing the aggregation device to add interfaces through interconnections with *satellite devices*. The entire system—the interconnected aggregation device and satellite devices—is called Junos Fusion. Junos Fusion simplifies network administration by appearing in the network topology as a single device, and the single device is managed from a single IP address.

This topic describes how to configure CoS on the different types of ports in Junos Fusion.

This topic covers:

Configuring Behavior Aggregate Classifiers on Satellite Device Extended Ports

Normally, you apply a behavior aggregate (BA) classifier to a logical interface on an EX9200 device at the [edit class-of-service interfaces *interface-name* unit *logical-unit-number*] hierarchy level. When traffic from a satellite device extended port reaches the aggregation device, the BA classifier configured for the logical interface level of the satellite device extended port is applied the same as it is for traffic from other non-extended ports to help determine the forwarding class of the traffic; policers and multifield classifiers can also factor in determining the forwarding class of the traffic. When the aggregation devices sends the traffic out to the satellite device, the forwarding class is carried in the 801.2BR header. The satellite device then uses the forwarding class to select the output queue at the *egress extended port*.

You can also apply a BA classifier at the physical interface level of an extended port. This classifier is used to determine the output queue at the *uplink port* of the satellite device.

NOTE: IP precedence classifiers are not supported on extended ports at the physical interface level. DSCP classifiers are supported, however.

NOTE: You cannot apply a physical interface-level classifier on an EX9200 local port.

To add a behavior aggregate classifier to the physical interface level of a satellite device extended port in Junos Fusion:

1. Define the classifier.

```
[edit class-of-service]
user@ex9200-agg-device#set classifiers dscp dscp-1 forwarding-class best-effort-3 loss-
priority low code-points 001010
```

2. Apply the classifier to the physical extended port.

```
[edit class-of-service]
user@ex9200-agg-device#set interfaces xe-100/0/33 classifiers dscp dscp-1
```

3. Commit the changes and then confirm the configuration.

```
[edit class-of-service]
user@ex9200-agg-device# show
classifiers {
  dscp dscp-1 {
    forwarding-class best-effort-3 {
      loss-priority low code-points 001010;
    }
  }
}
interfaces {
  xe-100/0/33 {
    classifiers {
      dscp dscp-1;
    }
  }
}
```

In the above configuration example, packets entering port xe-100/0/33 with a DSCP value of 001010 will be assigned a forwarding class of best-effort-3 to select the output queue at the uplink port as the packet travels from the satellite device to the aggregation device.

SEE ALSO

[Understanding Junos Fusion Ports | 20](#)

[Understanding How Behavior Aggregate Classifiers Prioritize Trusted Traffic](#)

[Overview of Assigning Service Levels to Packets Based on Multiple Packet Header Fields](#)

Configuring Rewrite Rules on Satellite Device Extended Ports

You apply rewrite rules to logical interfaces on satellite device extended ports.

To add a rewrite rule to a satellite device extended port in a Junos Fusion:

1. Define the rewrite rule.

```
[edit class-of-service]
user@ex9200-agg-device#set rewrite-rules ieee-802.1 rewrite1p forwarding-class best-effort
loss-priority low code-point 010
```

2. Apply the rewrite rule to a logical interface.

```
[edit class-of-service]
user@ex9200-agg-device#set interfaces xe-108/0/47 unit 0 rewrite-rules ieee-802.1 rewrite1p
```

3. Commit the changes and then confirm the configuration.

```
[edit class-of-service]
user@ex9200-agg-device# show
rewrite-rules {
  ieee-802.1 rewrite1p {
    forwarding-class best-effort {
      loss-priority low code-point 010;
    }
  }
}
interfaces {
  xe-108/0/47 {
    unit 0 {
```

```

rewrite-rules {
    ieee-802.1 rewrite-1p;
}
}
}
}

```

In Junos OS, rewrite rules only look at the forwarding class and packet loss priority of the packet (as assigned by a behavior aggregate or multifield classifier at ingress), not at the incoming CoS value, to determine the CoS value to write to the packet header at egress. The above configuration means that, for any packet exiting the xe-108/0/47.0 interface that has a forwarding class of best-effort and a packet loss priority of low, the ieee-802.1 CoS value will be rewritten to 010.

SEE ALSO

[Understanding Junos Fusion Ports | 20](#)

[Rewriting Packet Headers to Ensure Forwarding Behavior](#)

Changing the Default Scheduling Policy on an Aggregated Device Cascade Port

When a cascade port is created, two logical interfaces are automatically created:

- One in-band management logical interface (assigned unit 32769) for traffic that only flows between the aggregation device and the satellite devices, such as keepalives, for provisioning information, and for software updates.
- One for data logical interface (assigned unit 32770) for regular traffic that flows into and out of Junos Fusion.

Let's say, for example, that interface xe-0/0/1 is configured as a cascade port. The command `show interfaces xe-0/0/1 terse` produces output similar to the following:

```

user@ex9200-agg-device# run show interfaces xe-0/0/1 terse
Interface           Admin Link Proto  Local           Remote
xe-0/0/1            up   up
xe-0/0/1.32769      up   up   inet    10.0.0.5/30
xe-0/0/1.32770      up   up   bridge

```

The control logical interface (unit 32769) is automatically assigned an internal traffic control profile (`__cp_control_tc_prof`) that guarantees 50 Mbps of bandwidth for the logical interface, a 10 percent

shaping rate, and the default scheduling policy. The default scheduling policy is applied to the data logical interface. For example:

```

user@ex9200-agg-device# run show class-of-service interface xe-0/0/1
Physical interface: xe-0/0/1, Index: 144
Maximum usable queues: 8, Queues in use: 4
  Scheduler map: <default>, Index: 2
  Congestion-notification: Disabled

  Logical interface: xe-0/0/1.32769, Index: 344
Object          Name                Type                Index
Traffic-control-profile  __cp_control_tc_prof  Output              17227
Classifier         ipprec-compatibility  ip                  13

  Logical interface: xe-0/0/1.32770, Index: 343
Object          Name                Type                Index
Scheduler-map    <default>           Output              2

```

and:

```

user@ex9200-agg-device# run show class-of-service scheduler-hierarchy interface xe-0/0/1
Interface/          Shaping Guaranteed  Guaranteed/  Queue  Excess
Resource name       rate          rate          Excess      weight  weight
                    kbits        kbits        priority    high/low
xe-0/0/1.32770     10000000      0             Low Low      118     6
  BE                10000000      0             Low Low      6
  NC                10000000      0             Low Low      62  62
xe-0/0/1.32769     1000000      50000        Low Low      118     6
  BE                1000000      47500        Low Low      6
  NC                1000000      2500         Low Low      6

```

You can create custom forwarding classes and schedulers for the data logical interface by applying a customer scheduler map to that logical interface. For example, to apply a customer scheduler policy to the data logical interface:

1. Create customer schedulers.

```

[edit class-of-service]
user@ex9200-agg-device#set schedulers AF_SCH_CORE transmit-rate percent 40
user@ex9200-agg-device#set schedulers AF_SCH_CORE buffer-size percent 40
user@ex9200-agg-device#set schedulers AF_SCH_CORE priority medium-high

```

```

user@ex9200-agg-device#set schedulers BE_SCH_CORE transmit-rate percent 10
user@ex9200-agg-device#set schedulers BE_SCH_CORE buffer-size percent 10
user@ex9200-agg-device#set schedulers BE_SCH_CORE priority low
user@ex9200-agg-device#set schedulers EF_SCH_CORE transmit-rate percent 40
user@ex9200-agg-device#set schedulers EF_SCH_CORE buffer-size percent 40
user@ex9200-agg-device#set schedulers EF_SCH_CORE priority medium-low
user@ex9200-agg-device#set schedulers NC_SCH_CORE transmit-rate percent 10
user@ex9200-agg-device#set schedulers NC_SCH_CORE buffer-size percent 10
user@ex9200-agg-device#set schedulers NC_SCH_CORE priority high

```

2. Create a scheduler map.

```

[edit class-of-service]
user@ex9200-agg-device#set scheduler-maps CORE_SCHED_MAP forwarding-class BE scheduler
BE_SCH_CORE
user@ex9200-agg-device#set scheduler-maps CORE_SCHED_MAP forwarding-class EF scheduler
EF_SCH_CORE
user@ex9200-agg-device#set scheduler-maps CORE_SCHED_MAP forwarding-class AF scheduler
AF_SCH_CORE
user@ex9200-agg-device#set scheduler-maps CORE_SCHED_MAP forwarding-class NC scheduler
NC_SCH_CORE

```

3. Apply the scheduler map to the data logical interface.

```

[edit class-of-service]
user@ex9200-agg-device#set interfaces xe-0/0/1 unit 32770 scheduler-map CORE_SCHED_MAP

```

4. Commit the changes and then confirm the configuration.

```

[edit class-of-service]
user@ex9200-agg-device# show
interfaces {
  xe-0/0/1 {
    unit 32770 {
      scheduler-map CORE_SCHED_MAP;
    }
  }
}
scheduler-maps {
  CORE_SCHED_MAP {
    forwarding-class BE scheduler BE_SCH_CORE;

```



```

        forwarding-class EF scheduler EF_SCH_CORE;
        forwarding-class AF scheduler AF_SCH_CORE;
        forwarding-class NC scheduler NC_SCH_CORE;
    }
}
schedulers {
    BE_SCH_CORE {
        transmit-rate percent 10;
        buffer-size percent 10;
        priority low;
    }
    EF_SCH_CORE {
        transmit-rate percent 40;
        buffer-size percent 40;
        priority medium-low;
    }
    AF_SCH_CORE {
        transmit-rate percent 40;
        buffer-size percent 40;
        priority medium-high;
    }
    NC_SCH_CORE {
        transmit-rate percent 10;
        buffer-size percent 10;
        priority high;
    }
}

```

5. Verify your changes.

```

user@ex9200-agg-device# run show class-of-service interface xe-0/0/1
Physical interface: xe-0/0/1, Index: 144
Maximum usable queues: 8, Queues in use: 4
  Scheduler map: <default>, Index: 2
  Congestion-notification: Disabled

  Logical interface: xe-0/0/1.32769, Index: 344
Object          Name                Type                Index
Traffic-control-profile __cp_control_tc_prof Output              17227
Classifier      ipprec-compatibility ip                    13

  Logical interface: xe-0/0/1.32770, Index: 343

```

Object	Name	Type	Index
Scheduler-map	CORE_SCHED_MAP	Output	23433

and:

```
user@ex9200-agg-device# run show class-of-service scheduler-hierarchy interface xe-0/0/1
```

Interface/ Resource name	Shaping rate kbits	Guaranteed rate kbits	Guaranteed/ Excess priority	Queue weight	Excess weight high/low
xe-0/0/1.32770	10000000	0			1 1
BE	10000000	0	Low Low	12	
EF	10000000	0	Medium Low	50	
AF	10000000	0	Medium Low	50	
NC	10000000	0	High High	12	
xe-0/0/1.32769	1000000	50000			62 62
BE	1000000	47500	Low Low	118	
NC	1000000	2500	Low Low	6	

SEE ALSO

[How Schedulers Define Output Queue Properties](#)

[Default Schedulers Overview](#)

RELATED DOCUMENTATION

[Understanding CoS in Junos Fusion Enterprise | 867](#)

Extending a Junos Fusion Enterprise Using EVPN-MPLS

IN THIS CHAPTER

- [Understanding EVPN-MPLS Interworking with Junos Fusion Enterprise and MC-LAG | 880](#)
- [Example: EVPN-MPLS Interworking With Junos Fusion Enterprise | 886](#)

Understanding EVPN-MPLS Interworking with Junos Fusion Enterprise and MC-LAG

IN THIS SECTION

- [Benefits of Using EVPN-MPLS with Junos Fusion Enterprise and MC-LAG | 883](#)
- [BUM Traffic Handling | 883](#)
- [Split Horizon | 884](#)
- [MAC Learning | 885](#)
- [Handling Down Link Between Cascade and Uplink Ports in Junos Fusion Enterprise | 885](#)
- [Layer 3 Gateway Support | 886](#)

Starting with Junos OS Release 17.4R1, you can use Ethernet VPN (EVPN) to extend a Junos Fusion Enterprise or multichassis link aggregation group (MC-LAG) network over an MPLS network to a data center or campus network. With the introduction of this feature, you can now interconnect dispersed campus and data center sites to form a single Layer 2 virtual bridge.

[Figure 14 on page 881](#) shows a Junos Fusion Enterprise topology with two EX9200 switches that serve as aggregation devices (PE2 and PE3) to which the satellite devices are multihomed. The two aggregation devices use an interchassis link (ICL) and the Inter-Chassis Control Protocol (ICCP) protocol

from MC-LAG to connect and maintain the Junos Fusion Enterprise topology. PE1 in the EVPN-MPLS environment interworks with PE2 and PE3 in the Junos Fusion Enterprise with MC-LAG.

Figure 14: EVPN-MPLS Interworking with Junos Fusion Enterprise

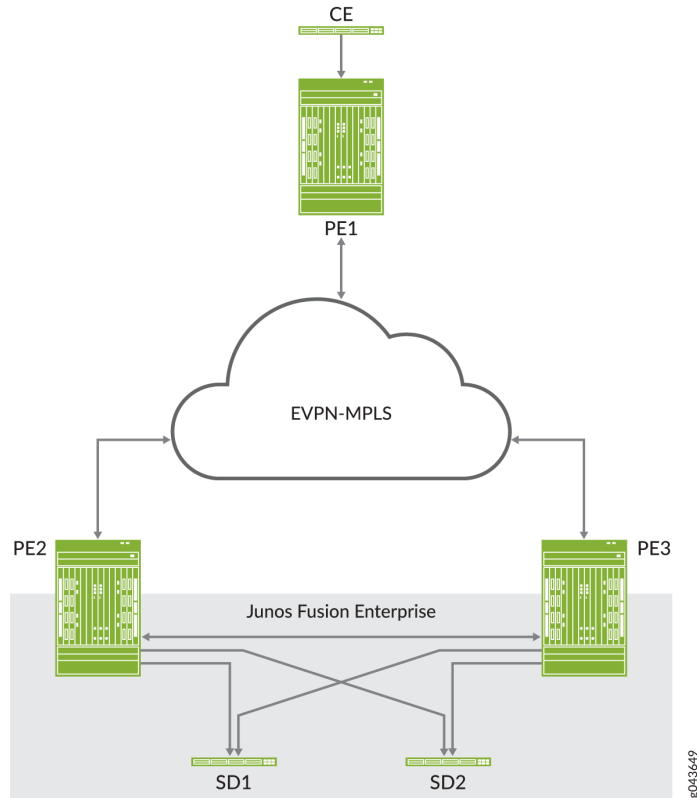

[Figure 15 on page 882](#) shows an MC-LAG topology in which customer edge (CE) device CE1 is multihomed to PE2 and PE3. PE2 and PE3 use an ICL and the ICCP protocol from MC-LAG to connect and maintain the topology. PE1 in the EVPN-MPLS environment interworks with PE2 and PE3 in the MC-LAG environment.

Figure 15: EVPN-MPLS Interworking with MC-LAG

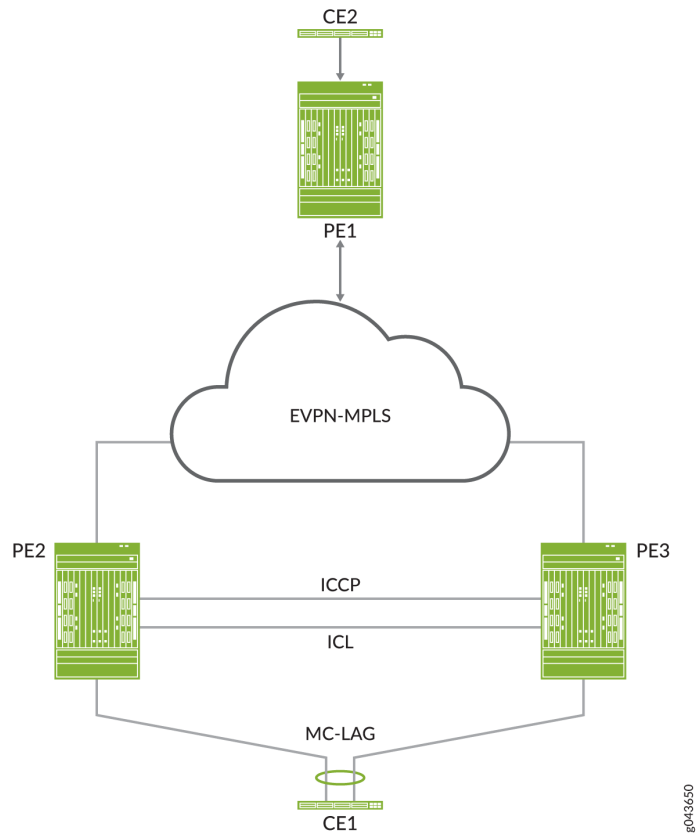

Throughout this topic, [Figure 14 on page 881](#) and [Figure 15 on page 882](#) serve as references to illustrate various scenarios and points.

The use cases depicted in [Figure 14 on page 881](#) and [Figure 15 on page 882](#) require the configuration of both EVPN multihoming in active-active mode and MC-LAG on PE2 and PE3. EVPN with multihoming active-active and MC-LAG have their own forwarding logic for handling traffic, in particular, broadcast, unknown unicast, and multicast (BUM) traffic. At times, the forwarding logic for EVPN with multihoming active-active and MC-LAG contradict each other and causes issues. This topic describes the issues and how the EVPN-MPLS interworking feature resolves these issues.

NOTE:

Other than the EVPN-MPLS interworking-specific implementations described in this topic, EVPN-MPLS, Junos Fusion Enterprise, and MC-LAG offer the same functionality and function the same as the standalone features.

Benefits of Using EVPN-MPLS with Junos Fusion Enterprise and MC-LAG

Use EVPN-MPLS with Junos Fusion Enterprise and MC-LAG to interconnect dispersed campus and data center sites to form a single Layer 2 virtual bridge.

BUM Traffic Handling

In the use cases shown in [Figure 14 on page 881](#) and [Figure 15 on page 882](#), PE1, PE2, and PE3 are EVPN peers, and PE2 and PE3 are MC-LAG peers. Both sets of peers exchange control information and forward traffic to each other, which causes issues. [Table 48 on page 883](#) outlines the issues that arise, and how Juniper Networks resolves the issues in its implementation of the EVPN-MPLS interworking feature.

Table 48: BUM Traffic: Issues and Resolutions

BUM Traffic Direction	EVPN Interworking with Junos Fusion Enterprise and MC-LAG Logic	Issue	Juniper Networks Implementation Approach
North bound (PE2 receives BUM packet from a locally attached single- or dual-homed interfaces).	PE2 floods BUM packet to the following: <ul style="list-style-type: none"> All locally attached interfaces, including the ICL, for a particular broadcast domain. All remote EVPN peers for which PE2 has received inclusive multicast routes. 	Between PE2 and PE3, there are two BUM forwarding paths—the MC-LAG ICL and an EVPN-MPLS path. The multiple forwarding paths result in packet duplication and loops.	<ul style="list-style-type: none"> BUM traffic is forwarded on the ICL only. Incoming traffic from the EVPN core is not forwarded on the ICL. Incoming traffic from the ICL is not forwarded to the EVPN core.
South bound (PE1 forwards BUM packet to PE2 and PE3).	PE2 and PE3 both receive a copy of the BUM packet and flood the packet out of all of their local interfaces, including the ICL.	PE2 and PE3 both forward the BUM packet out of the ICL, which results in packet duplication and loops.	

Split Horizon

In the use cases shown in [Figure 14 on page 881](#) and [Figure 15 on page 882](#), split horizon prevents multiple copies of a BUM packet from being forwarded to a CE device (satellite device). However, the EVPN-MPLS and MC-LAG split horizon implementations contradict each other, which causes an issue. [Table 49 on page 884](#) explains the issue and how Juniper Networks resolves it in its implementation of the EVPN-MPLS interworking feature.

Table 49: BUM Traffic: Split Horizon-Related Issue and Resolution

BUM Traffic Direction	EVPN Interworking with Junos Fusion Enterprise and MC-LAG Logic	Issue	Juniper Networks Implementation Approach
North bound (PE2 receives BUM packet from a locally attached dual-homed interface).	<ul style="list-style-type: none"> Per EVPN-MPLS forwarding logic: <ul style="list-style-type: none"> Only the designated forwarder (DF) for the Ethernet segment (ES) can forward BUM traffic. The local bias rule, in which the local peer forwards the BUM packet and the remote peer drops it, is not supported. Per MC-LAG forwarding logic, local bias is supported. 	The EVPN-MPLS and MC-LAG forwarding logic contradicts each other and can prevent BUM traffic from being forwarded to the ES.	Support local bias, thereby ignoring the DF and non-DF status of the port for locally switched traffic.
South bound (PE1 forwards BUM packet to PE2 and PE3).	Traffic received from PE1 follows the EVPN DF and non-DF forwarding rules for a multihomed ES.	None.	Not applicable.

MAC Learning

EVPN and MC-LAG use the same method for learning MAC addresses—namely, a PE device learns MAC addresses from its local interfaces and synchronizes the addresses to its peers. However, given that both EVPN and MC-LAG are synchronizing the addresses, an issue arises.

Table 50 on page 885 describes the issue and how the EVPN-MPLS interworking implementation prevents the issue. The use cases shown in Figure 14 on page 881 and Figure 15 on page 882 illustrate the issue. In both use cases, PE1, PE2, and PE3 are EVPN peers, and PE2 and PE3 are MC-LAG peers.

Table 50: MAC Learning: EVPN and MC-LAG Synchronization Issue and Implementation Details

MAC Synchronization Use Case	EVPN Interworking with Junos Fusion Enterprise and MC-LAG Logic	Issue	Juniper Networks Implementation Approach
MAC addresses learned locally on single- or dual-homed interfaces on PE2 and PE3.	<ul style="list-style-type: none"> Between the EVPN peers, MAC addresses are synchronized using the EVPN BGP control plane. Between the MC-LAG peers, MAC addresses are synchronized using the MC-LAG ICCP control plane. 	PE2 and PE3 function as both EVPN peers and MC-LAG peers, which result in these devices having multiple MAC synchronization paths.	<ul style="list-style-type: none"> For PE1: use MAC addresses synchronized by EVPN BGP control plane. For PE2 and PE3: use MAC addresses synchronized by MC-LAG ICCP control plane.
MAC addresses learned locally on single- or dual-homed interfaces on PE1.	Between the EVPN peers, MAC addresses are synchronized using the EVPN BGP control plane.	None.	Not applicable.

Handling Down Link Between Cascade and Uplink Ports in Junos Fusion Enterprise

NOTE: This section applies only to EVPN-MPLS interworking with a Junos Fusion Enterprise.

In the Junos Fusion Enterprise shown in Figure 14 on page 881, assume that aggregation device PE2 receives a BUM packet from PE1 and that the link between the cascade port on PE2 and the corresponding uplink port on satellite device SD1 is down. Regardless of whether the BUM packet is

handled by MC-LAG or EVPN multihoming active-active, the result is the same—the packet is forwarded via the ICL interface to PE3, which forwards it to dual-homed SD1.

To further illustrate how EVPN with multihoming active-active handles this situation with dual-homed SD1, assume that the DF interface resides on PE2 and is associated with the down link and that the non-DF interface resides on PE3. Typically, per EVPN with multihoming active-active forwarding logic, the non-DF interface drops the packet. However, because of the down link associated with the DF interface, PE2 forwards the BUM packet via the ICL to PE3, and the non-DF interface on PE3 forwards the packet to SD1.

Layer 3 Gateway Support

The EVPN-MPLS interworking feature supports the following Layer 3 gateway functionality for extended bridge domains and VLANs:

- Integrated routing and bridging (IRB) interfaces to forward traffic between the extended bridge domains or VLANs.
- Default Layer 3 gateways to forward traffic from a physical (bare-metal) server in an extended bridge domain or VLAN to a physical server or virtual machine in another extended bridge domain or VLAN.

Release History Table

Release	Description
17.4R1	Starting with Junos OS Release 17.4R1, you can use Ethernet VPN (EVPN) to extend a Junos Fusion Enterprise or multichassis link aggregation group (MC-LAG) network over an MPLS network to a data center or campus network.

Example: EVPN-MPLS Interworking With Junos Fusion Enterprise

IN THIS SECTION

- [Requirements | 887](#)
- [Overview and Topology | 887](#)
- [Aggregation Device \(PE1 and PE2\) Configuration | 890](#)
- [PE3 Configuration | 902](#)

This example shows how to use Ethernet VPN (EVPN) to extend a Junos Fusion Enterprise over an MPLS network to a geographically distributed campus or enterprise network.

EVPN-MPLS interworking is supported with a Junos Fusion Enterprise, which is based on a multichassis link aggregation group (MC-LAG) infrastructure to provide redundancy for the EX9200 switches that function as aggregation devices.

The aggregation devices in the Junos Fusion Enterprise are connected to a provider edge (PE) device in an MPLS network. The PE device can be either an MX Series router or an EX9200 switch.

This example shows how to configure the aggregation devices in the Junos Fusion Enterprise and the PE device in the MPLS network to interwork with each other.

Requirements

This example uses the following hardware and software components:

- Three EX9200 switches:
 - PE1 and PE2, which both function as aggregation devices in the Junos Fusion Enterprise and EVPN BGP peers in the EVPN-MPLS overlay network.
 - PE3, which functions as an EVPN BGP peer in the EVPN-MPLS overlay network.
- The EX9200 switches are running Junos OS Release 17.4R1 or later software.

NOTE: Although the Junos Fusion Enterprise includes three satellite devices, this example focuses on the configuration of the PE1, PE2, and PE3. For more information about configuring satellite devices, see [Configuring or Expanding a Junos Fusion Enterprise](#).

Overview and Topology

[Figure 16 on page 888](#) shows a Junos Fusion Enterprise with dual aggregation devices PE1 and PE2. The aggregation devices are connected using an interchassis link (ICL) and communicate with each other using the Inter-Chassis Control Protocol (ICCP).

Figure 16: EVPN-MPLS Interworking with Junos Fusion Enterprise

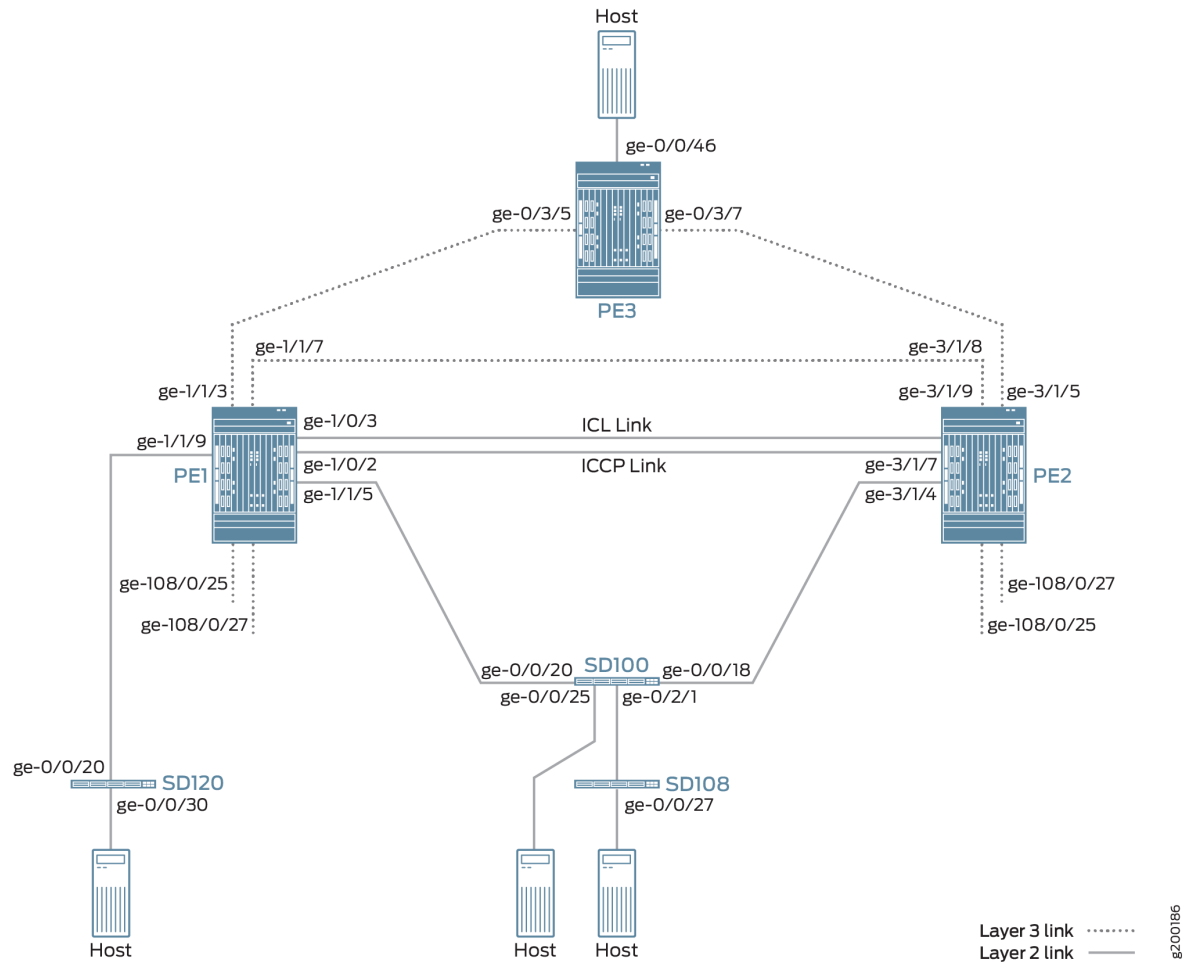

The Junos Fusion Enterprise also includes three satellite devices. Satellite device SD120 is a standalone satellite device that has a single-homed connection to PE1. Satellite devices SD100 and SD108 are included in a cluster named Cluster_100_108. SD100 is the only cluster member with a connection to an aggregation device, in this case, multihomed connections to PE1 and PE2.

The topology in [Figure 16 on page 888](#) also includes PE3, which is positioned at the edge of an MPLS network. PE3 functions as the gateway between the Junos Fusion Enterprise network and a geographically distributed campus or enterprise network. PE1, PE2, and PE3 run EVPN, which enables hosts in the Junos Fusion Enterprise network to communicate with hosts in the campus or enterprise network by way of the intervening MPLS network.

From the perspective of the EVPN-MPLS interworking feature, PE3 functions solely as an EVPN BGP peer, and PE1 and PE2 in the Junos Fusion Enterprise have dual roles:

- Aggregation devices in the Junos Fusion Enterprise.
- EVPN BGP peers in the EVPN-MPLS network.

Because of the dual roles, PE1 and PE2 are configured with Junos Fusion Enterprise, EVPN, BGP, and MPLS attributes.

[Table 51 on page 889](#) outlines key Junos Fusion Enterprise and EVPN (BGP and MPLS) attributes configured on PE1, PE2, and PE3.

Table 51: Key Junos Fusion Enterprise and EVPN (BGP and MPLS) Attributes Configured on PE1, PE2, and PE3

Key Attributes	PE1	PE2	PE3
Junos Fusion Enterprise Attributes			
Interfaces	ICL: ge-1/0/3 ICCP: ge-1/0/2	ICL: ge-3/1/9 ICCP: ge-3/1/7	Not applicable
EVPN-MPLS			
Interfaces	Connection to PE3: ge-1/1/3 Connection to PE2: ge-1/1/7	Connection to PE3: ge-3/1/5 Connection to PE1: ge-3/1/8	Connection to PE1: ge-0/3/5 Connection to PE2: ge-0/3/7
IP addresses	BGP peer address: 10.25.0.1	BGP peer address: 10.25.0.2	BGP peer address: 10.25.0.3
Autonomous system	100	100	100
Virtual switch routing instances	evpn1	evpn1	evpn1

Note the following about the EVPN-MPLS interworking feature and its configuration:

- You must configure Ethernet segment identifiers (ESIs) on the dual-homed extended ports in the Junos Fusion Enterprise. The ESIs enable EVPN to identify the dual-homed extended ports.
- The only type of routing instance that is supported is the virtual switch instance (`set routing-instances name instance-type virtual-switch`).
- Only one virtual switch instance is supported with Junos Fusion Enterprise.

- On the aggregation devices in the Junos Fusion Enterprise, you must include the `bgp-peer` configuration statement in the `[edit routing-instances name protocols evpn mclag]` hierarchy level. This configuration statement enables the interworking of EVPN-MPLS with Junos Fusion Enterprise on the aggregation devices.
- Address Resolution Protocol (ARP) suppression is not supported.

Aggregation Device (PE1 and PE2) Configuration

IN THIS SECTION

- [CLI Quick Configuration | 890](#)
- [PE1: Configuring Junos Fusion Enterprise | 894](#)
- [PE1: Configuring EVPN-MPLS | 896](#)
- [PE2: Configuring Junos Fusion Enterprise | 898](#)
- [PE2: Configuring EVPN-MPLS | 900](#)

To configure aggregation devices PE1 and PE2, perform these tasks.

NOTE: This section focuses on enabling EVPN-MPLS on PE1 and PE2. As a result, the Junos Fusion Enterprise configuration on PE1 and PE2 is performed without the use of the configuration synchronization feature. For information about configuration synchronization, see [Understanding Configuration Synchronization](#).

CLI Quick Configuration

PE1: Junos Fusion Enterprise Configuration

```
set interfaces ge-1/1/9 cascade-port
set interfaces ge-1/1/5 cascade-port
set chassis satellite-management fpc 120 cascade-ports ge-1/1/9
set chassis satellite-management cluster Cluster_100_108 cluster-id 2
set chassis satellite-management cluster Cluster_100_108 cascade-ports ge-1/1/5
set chassis satellite-management cluster Cluster_100_108 fpc 100 alias SD100
set chassis satellite-management cluster Cluster_100_108 fpc 100 system-id 88:e0:f3:1f:3d:50
set chassis satellite-management cluster Cluster_100_108 fpc 108 alias SD108
set chassis satellite-management cluster Cluster_100_108 fpc 108 system-id 88:e0:f3:1f:c8:d1
```

```

set chassis satellite-management cluster Cluster_100_108 fpc 100 member-id 1
set chassis satellite-management cluster Cluster_100_108 fpc 108 member-id 8
set chassis satellite-management upgrade-groups upgrade_120 satellite 120
set chassis satellite-management upgrade-groups upgrade_100 satellite 100
set chassis satellite-management redundancy-groups rg1 redundancy-group-id 2
set chassis satellite-management redundancy-groups chassis-id 1
set chassis satellite-management redundancy-groups rg1 peer-chassis-id 2 inter-chassis-link
ge-1/0/3
set chassis satellite-management redundancy-groups rg1 cluster Cluster_100_108
set interfaces ge-1/0/2 description iccp-link
set interfaces ge-1/0/2 unit 0 family inet address 10.20.20.1/24
set interfaces ge-1/0/3 description icl-link
set interfaces ge-1/0/3 unit 0 family ethernet-switching interface-mode trunk
set interfaces ge-1/0/3 unit 0 family ethernet-switching vlan members 100
set switch-options service-id 1

```

PE1: EVPN-MPLS Configuration

```

set interfaces lo0 unit 0 family inet address 10.25.0.1/32
set interfaces ge-1/1/3 unit 0 family inet address 10.0.1.1/30
set interfaces ge-1/1/3 unit 0 family mpls
set interfaces ge-1/1/7 unit 0 family inet address 10.0.3.1/30
set interfaces ge-1/1/7 unit 0 family mpls
set interfaces ge-108/0/25 unit 0 esi 00:01:02:03:04:00:01:02:04:26
set interfaces ge-108/0/25 unit 0 esi all-active
set interfaces ge-108/0/25 unit 0 family ethernet-switching vlan members v100
set interfaces ge-108/0/27 unit 0 esi 00:01:02:03:04:00:01:02:04:28
set interfaces ge-108/0/27 unit 0 esi all-active
set interfaces ge-108/0/27 unit 0 family ethernet-switching vlan members v100
set routing-options router-id 10.25.0.1
set routing-options autonomous-system 100
set protocols mpls interface lo0.0
set protocols mpls interface ge-1/1/3.0
set protocols mpls interface ge-1/1/7.0
set protocols bgp local-address 10.25.0.1
set protocols bgp peer-as 100
set protocols bgp local-as 100
set protocols bgp group evpn-mes type internal
set protocols bgp group evpn-mes family evpn signaling
set protocols bgp group evpn-mes peer-as 100
set protocols bgp group evpn-mes neighbor 10.25.0.2
set protocols bgp group evpn-mes neighbor 10.25.0.3

```

```

set protocols ospf traffic-engineering
set protocols ospf area 0.0.0.0 interface ge-1/1/3.0
set protocols ospf area 0.0.0.0 interface lo0.0
set protocols ospf area 0.0.0.0 interface fxp0.0 disable
set protocols ospf area 0.0.0.0 interface ge-1/1/7.0
set protocols ldp interface lo0.0
set protocols ldp interface ge-1/1/3.0
set protocols ldp interface ge-1/1/7.0
set routing-instances evpn1 instance-type virtual-switch
set routing-instances evpn1 interface ge-108/0/25.0
set routing-instances evpn1 interface ge-108/0/27.0
set routing-instances evpn1 interface ge-1/0/3.0
set routing-instances evpn1 route-distinguisher 10.25.0.1:1
set routing-instances evpn1 vrf-target target:100:1
set routing-instances evpn1 protocols evpn label-allocation per-instance
set routing-instances evpn1 protocols evpn extended-vlan-list 100
set routing-instances evpn1 protocols evpn mlag bgp-peer 10.25.0.2
set routing-instances evpn1 switch-options service-id 2
set routing-instances evpn1 vlans v100 vlan-id 100

```

PE2: Junos Fusion Enterprise Configuration

```

set interfaces ge-3/1/4 cascade-port
set chassis satellite-management cluster Cluster_100_108 cluster-id 2
set chassis satellite-management cluster Cluster_100_108 cascade-ports ge-3/1/4
set chassis satellite-management cluster Cluster_100_108 fpc 100 alias SD100
set chassis satellite-management cluster Cluster_100_108 fpc 100 system-id 88:e0:f3:1f:3d:50
set chassis satellite-management cluster Cluster_100_108 fpc 108 alias SD108
set chassis satellite-management cluster Cluster_100_108 fpc 108 system-id 88:e0:f3:1f:c8:d1
set chassis satellite-management cluster Cluster_100_108 fpc 100 member-id 1
set chassis satellite-management cluster Cluster_100_108 fpc 108 member-id 8
set chassis satellite-management upgrade-groups upgrade_100 satellite 100
set chassis satellite-management redundancy-groups rg1 redundancy-group-id 2
set chassis satellite-management redundancy-groups chassis-id 2
set chassis satellite-management redundancy-groups rg1 peer-chassis-id 1 inter-chassis-link
ge-3/1/9
set chassis satellite-management redundancy-groups rg1 cluster Cluster_100_108
set interfaces ge-3/1/7 description iccp-link
set interfaces ge-3/1/7 unit 0 family inet address 10.20.20.2/24
set interfaces ge-3/1/9 description icl-link
set interfaces ge-3/1/9 unit 0 family ethernet-switching interface-mode trunk

```

```

set interfaces ge-3/1/9 unit 0 family ethernet-switching vlan members 100
set switch-options service-id 1

```

PE2: EVPN-MPLS Configuration

```

set interfaces lo0 unit 0 family inet address 10.25.0.2/32
set interfaces ge-3/1/5 unit 0 family inet address 10.0.4.2/30
set interfaces ge-3/1/5 unit 0 family mpls
set interfaces ge-3/1/8 unit 0 family inet address 10.0.3.2/30
set interfaces ge-3/1/8 unit 0 family mpls
set interfaces irb unit 0 family inet address 10.5.5.1/24 virtual-gateway-address 10.5.5.5
set interfaces ge-108/0/25 unit 0 esi 00:01:02:03:04:00:01:02:04:26
set interfaces ge-108/0/25 unit 0 esi all-active
set interfaces ge-108/0/25 unit 0 family ethernet-switching vlan members v100
set interfaces ge-108/0/27 unit 0 esi 00:01:02:03:04:00:01:02:04:28
set interfaces ge-108/0/27 unit 0 esi all-active
set interfaces ge-108/0/27 unit 0 family ethernet-switching vlan members v100
set routing-options router-id 10.25.0.2
set routing-options autonomous-system 100
set protocols mpls interface lo0.0
set protocols mpls interface ge-3/1/5.0
set protocols mpls interface ge-3/1/8.0
set protocols bgp local-address 10.25.0.2
set protocols bgp peer-as 100
set protocols bgp local-as 100
set protocols bgp group evpn-mes type internal
set protocols bgp group evpn-mes family evpn signaling
set protocols bgp group evpn-mes peer-as 100
set protocols bgp group evpn-mes neighbor 10.25.0.1
set protocols bgp group evpn-mes neighbor 10.25.0.3
set protocols ospf traffic-engineering
set protocols ospf area 0.0.0.0 interface ge-3/1/5.0
set protocols ospf area 0.0.0.0 interface lo0.0
set protocols ospf area 0.0.0.0 interface fxp0.0 disable
set protocols ospf area 0.0.0.0 interface ge-3/1/8.0
set protocols ldp interface lo0.0
set protocols ldp interface ge-3/1/5.0
set protocols ldp interface ge-3/1/8.0
set routing-instances evpn1 instance-type virtual-switch
set routing-instances evpn1 interface ge-108/0/25.0
set routing-instances evpn1 interface ge-108/0/27.0
set routing-instances evpn1 interface ge-3/1/9.0

```



```

set routing-instances evpn1 route-distinguisher 10.25.0.2:1
set routing-instances evpn1 vrf-target target:100:1
set routing-instances evpn1 protocols evpn label-allocation per-instance
set routing-instances evpn1 protocols evpn extended-vlan-list 100
set routing-instances evpn1 protocols evpn mlag bgp-peer 10.25.0.1
set routing-instances evpn1 switch-options service-id 2
set routing-instances evpn1 vlans v100 vlan-id 100
set routing-instances evpn1 vlans v100 l3-interface irb.0

```

PE1: Configuring Junos Fusion Enterprise

Step-by-Step Procedure

1. Configure the cascade ports.

```

[edit]
user@switch# set interfaces ge-1/1/9 cascade-port
user@switch# set interfaces ge-1/1/5 cascade-port

```

2. Configure the FPC slot ID for standalone satellite device SD120 and map it to a cascade port.

```

[edit]
user@switch# set chassis satellite-management fpc 120 cascade-ports ge-1/1/9

```

3. Create a satellite device cluster, and assign a name and a cluster ID to it.

```

[edit]
user@switch# set chassis satellite-management cluster Cluster_100_108 cluster-id 2

```

4. Define the cascade ports associated with the satellite device cluster.

```

[edit]
user@switch# set chassis satellite-management cluster Cluster_100_108 cascade-ports ge-1/1/5
user@switch# set chassis satellite-management cluster Cluster_100_108 cascade-ports ge-1/1/9

```

5. Configure the FPC slot ID number, and map it to the MAC address of satellite devices SD100 and SD108, respectively.

```
[edit]
user@switch# set chassis satellite-management cluster Cluster_100_108 fpc 100 alias SD100
user@switch# set chassis satellite-management cluster Cluster_100_108 fpc 100 system-id
88:e0:f3:1f:3d:50
user@switch# set chassis satellite-management cluster Cluster_100_108 fpc 108 alias SD108
user@switch# set chassis satellite-management cluster Cluster_100_108 fpc 108 system-id
88:e0:f3:1f:c8:d1
```

6. Assign a member ID to each satellite device in the satellite device cluster.

```
[edit]
user@switch# set chassis satellite-management cluster Cluster_100_108 fpc 100 member-id 1
user@switch# set chassis satellite-management cluster Cluster_100_108 fpc 108 member-id 8
```

7. Create two satellite software upgrade groups—one that includes satellite device SD120 and another that includes satellite device SD100.

```
[edit]
user@switch# set chassis satellite-management upgrade-groups upgrade_120 satellite 120
user@switch# set chassis satellite-management upgrade-groups upgrade_100 satellite 100
```

8. Create and configure a redundancy group, which includes the aggregation devices and satellite devices in Cluster_100_108.

```
[edit]
user@switch# set chassis satellite-management redundancy-groups rg1 redundancy-group-id 2
user@switch# set chassis satellite-management redundancy-groups chassis-id 1
user@switch# set chassis satellite-management redundancy-groups rg1 peer-chassis-id 2 inter-
chassis-link ge-1/0/3
user@switch# set chassis satellite-management redundancy-groups rg1 cluster Cluster_100_108
```

9. Configure the ICL and ICCP links.

```
[edit]
user@switch# set interfaces ge-1/0/2 description iccp-link
```

```

user@switch# set interfaces ge-1/0/2 unit 0 family inet address 10.20.20.1/24
user@switch# set interfaces ge-1/0/3 description icl-link
user@switch# set interfaces ge-1/0/3 unit 0 family ethernet-switching interface-mode trunk
user@switch# set interfaces ge-1/0/3 unit 0 family ethernet-switching vlan members 100
user@switch# set switch-options service-id 1

```

NOTE: While this step shows the configuration of interface ge-1/0/2, which is designated as the ICCP interface, it does not show how to configure the ICCP attributes on interface ge-1/0/2. By default, ICCP is automatically provisioned in a Junos Fusion Enterprise using dual aggregation devices. For more information about the automatic provisioning of ICCP, see [Configuring or Expanding a Junos Fusion Enterprise](#).

PE1: Configuring EVPN-MPLS

Step-by-Step Procedure

1. Configure the loopback interface and the interfaces connected to the other PE devices.

```

[edit]
user@switch# set interfaces lo0 unit 0 family inet address 10.25.0.1/32
user@switch# set interfaces ge-1/1/3 unit 0 family inet address 10.0.1.1/30
user@switch# set interfaces ge-1/1/3 unit 0 family mpls
user@switch# set interfaces ge-1/1/7 unit 0 family inet address 10.0.3.1/30
user@switch# set interfaces ge-1/1/7 unit 0 family mpls

```

2. Configure the extended ports with EVPN multihoming in active-active mode, an ESI, and map the ports to VLAN v100..

```

[edit]
user@switch# set interfaces ge-108/0/25 unit 0 esi 00:01:02:03:04:00:01:02:04:26
user@switch# set interfaces ge-108/0/25 unit 0 esi all-active
user@switch# set interfaces ge-108/0/25 unit 0 family ethernet-switching vlan members v100
user@switch# set interfaces ge-108/0/27 unit 0 esi 00:01:02:03:04:00:01:02:04:28
user@switch# set interfaces ge-108/0/27 unit 0 esi all-active
user@switch# set interfaces ge-108/0/27 unit 0 family ethernet-switching vlan members v100

```

3. Assign a router ID and the autonomous system in which PE1, PE2, and PE3 reside.

```
[edit]
user@switch# set routing-options router-id 10.25.0.1
user@switch# set routing-options autonomous-system 100
```

4. Enable MPLS on the loopback interface and interfaces ge-1/1/3.0 and ge-1/1/7.0.

```
[edit]
user@switch# set protocols mpls interface lo0.0
user@switch# set protocols mpls interface ge-1/1/3.0
user@switch# set protocols mpls interface ge-1/1/7.0
```

5. Configure an IBGP overlay that includes PE1, PE2, and PE3.

```
[edit]
user@switch# set protocols bgp local-address 10.25.0.1
user@switch# set protocols bgp peer-as 100
user@switch# set protocols bgp local-as 100
user@switch# set protocols bgp group evpn-mes type internal
user@switch# set protocols bgp group evpn-mes family evpn signaling
user@switch# set protocols bgp group evpn-mes peer-as 100
user@switch# set protocols bgp group evpn-mes neighbor 10.25.0.2
user@switch# set protocols bgp group evpn-mes neighbor 10.25.0.3
```

6. Configure OSPF as the internal routing protocol for EVPN by specifying an area ID and interfaces on which EVPN-MPLS is enabled.

```
[edit]
user@switch# set protocols ospf traffic-engineering
user@switch# set protocols ospf area 0.0.0.0 interface ge-1/1/3.0
user@switch# set protocols ospf area 0.0.0.0 interface lo0.0
user@switch# set protocols ospf area 0.0.0.0 interface fxp0.0 disable
user@switch# set protocols ospf area 0.0.0.0 interface ge-1/1/7.0
```

7. Configure the Label Distribution Protocol (LDP) on the loopback interface and the interfaces on which EVPN-MPLS is enabled.

```
[edit]
user@switch# set protocols ldp interface lo0.0
user@switch# set protocols ldp interface ge-1/1/3.0
user@switch# set protocols ldp interface ge-1/1/7.0
```

8. Configure a virtual switch routing instance for VLAN v100, and include the interfaces and other entities associated with the VLAN.

```
[edit]
user@switch# set routing-instances evpn1 instance-type virtual-switch
user@switch# set routing-instances evpn1 interface ge-108/0/25.0
user@switch# set routing-instances evpn1 interface ge-108/0/27.0
user@switch# set routing-instances evpn1 interface ge-1/0/3.0
user@switch# set routing-instances evpn1 route-distinguisher 10.25.0.1:1
user@switch# set routing-instances evpn1 vrf-target target:100:1
user@switch# set routing-instances evpn1 protocols evpn label-allocation per-instance
user@switch# set routing-instances evpn1 protocols evpn extended-vlan-list 100
user@switch# set routing-instances evpn1 protocols evpn mclag bgp-peer 10.25.0.2
user@switch# set routing-instances evpn1 switch-options service-id 2
user@switch# set routing-instances evpn1 vlans v100 vlan-id 100
```

PE2: Configuring Junos Fusion Enterprise

Step-by-Step Procedure

1. Configure the cascade port.

```
[edit]
user@switch# set interfaces ge-3/1/4 cascade-port
```

2. Create a satellite device cluster, and assign a name and a cluster ID to it.

```
[edit]
user@switch# set chassis satellite-management cluster Cluster_100_108 cluster-id 2
```

3. Define the cascade port associated with the satellite device cluster.

```
[edit]
user@switch# set chassis satellite-management cluster Cluster_100_108 cascade-ports ge-3/1/4
```

4. Configure the FPC slot ID number, and map it to the MAC address of satellite devices SD100 and SD108, respectively.

```
[edit]
user@switch# set chassis satellite-management cluster Cluster_100_108 fpc 100 alias SD100
user@switch# set chassis satellite-management cluster Cluster_100_108 fpc 100 system-id
88:e0:f3:1f:3d:50
user@switch# set chassis satellite-management cluster Cluster_100_108 fpc 108 alias SD108
user@switch# set chassis satellite-management cluster Cluster_100_108 fpc 108 system-id
88:e0:f3:1f:c8:d1
```

5. Assign a member ID to each satellite device in the satellite device cluster.

```
[edit]
user@switch# set chassis satellite-management cluster Cluster_100_108 fpc 100 member-id 1
user@switch# set chassis satellite-management cluster Cluster_100_108 fpc 108 member-id 8
```

6. Create a satellite software upgrade group that includes satellite device SD100.

```
[edit]
user@switch# set chassis satellite-management upgrade-groups upgrade_100 satellite 100
```

7. Create and configure a redundancy group, which includes the aggregation devices and satellite devices in Cluster_100_108.

```
[edit]
user@switch# set chassis satellite-management redundancy-groups rg1 redundancy-group-id 2
user@switch# set chassis satellite-management redundancy-groups chassis-id 2
user@switch# set chassis satellite-management redundancy-groups rg1 peer-chassis-id 1 inter-
chassis-link ge-3/1/9
user@switch# set chassis satellite-management redundancy-groups rg1 cluster Cluster_100_108
```

8. Configure the ICL and ICCP links.

```
[edit]
user@switch# set interfaces ge-3/1/7 description iccp-link
user@switch# set interfaces ge-3/1/7 unit 0 family inet address 10.20.20.2/24
user@switch# set interfaces ge-3/1/9 description icl-link
user@switch# set interfaces ge-3/1/9 unit 0 family ethernet-switching interface-mode trunk
user@switch# set interfaces ge-3/1/9 unit 0 family ethernet-switching vlan members 100
user@switch# set switch-options service-id 1
```

NOTE: While this step shows the configuration of interface ge-3/1/7, which is designated as the ICCP interface, it does not show how to configure the ICCP attributes on interface ge-3/1/7. By default, ICCP is automatically provisioned in a Junos Fusion Enterprise using dual aggregation devices. For more information about the automatic provisioning of ICCP, see [Configuring or Expanding a Junos Fusion Enterprise](#).

PE2: Configuring EVPN-MPLS

Step-by-Step Procedure

1. Configure the loopback interface, the interfaces connected to the other PE devices, and an IRB interface that is also configured as a default Layer 3 gateway.

```
[edit]
user@switch# set interfaces lo0 unit 0 family inet address 10.25.0.2/32
user@switch# set interfaces ge-3/1/5 unit 0 family inet address 10.0.4.2/30
user@switch# set interfaces ge-3/1/5 unit 0 family mpls
user@switch# set interfaces ge-3/1/8 unit 0 family inet address 10.0.3.2/30
user@switch# set interfaces ge-3/1/8 unit 0 family mpls
user@switch# set interfaces irb unit 0 family inet address 10.5.5.1/24 virtual-gateway-address 10.5.5.5
```

2. Configure the extended ports with EVPN multihoming in active-active mode, an ESI, and map the ports to VLAN v100..

```
[edit]
user@switch# set interfaces ge-108/0/25 unit 0 esi 00:01:02:03:04:00:01:02:04:26
user@switch# set interfaces ge-108/0/25 unit 0 esi all-active
```

```

user@switch# set interfaces ge-108/0/25 unit 0 family ethernet-switching vlan members v100
user@switch# set interfaces ge-108/0/27 unit 0 esi 00:01:02:03:04:00:01:02:04:28
user@switch# set interfaces ge-108/0/27 unit 0 esi all-active
user@switch# set interfaces ge-108/0/27 unit 0 family ethernet-switching vlan members v100

```

3. Assign a router ID and the autonomous system in which PE1, PE2, and PE3 reside.

```

[edit]
user@switch# set routing-options router-id 10.25.0.2
user@switch# set routing-options autonomous-system 100

```

4. Enable MPLS on the loopback interface and interfaces ge-3/1/5.0 and ge-3/1/8.0.

```

[edit]
user@switch# set protocols mpls interface lo0.0
user@switch# set protocols mpls interface ge-3/1/5.0
user@switch# set protocols mpls interface ge-3/1/8.0

```

5. Configure an IBGP overlay that includes PE1, PE2, and PE3.

```

[edit]
user@switch# set protocols bgp local-address 10.25.0.2
user@switch# set protocols bgp peer-as 100
user@switch# set protocols bgp local-as 100
user@switch# set protocols bgp group evpn-mes type internal
user@switch# set protocols bgp group evpn-mes family evpn signaling
user@switch# set protocols bgp group evpn-mes peer-as 100
user@switch# set protocols bgp group evpn-mes neighbor 10.25.0.1
user@switch# set protocols bgp group evpn-mes neighbor 10.25.0.3

```

6. Configure OSPF as the internal routing protocol for EVPN by specifying an area ID and interfaces on which EVPN-MPLS is enabled.

```

[edit]
user@switch# set protocols ospf traffic-engineering
user@switch# set protocols ospf area 0.0.0.0 interface ge-3/1/5.0
user@switch# set protocols ospf area 0.0.0.0 interface lo0.0

```



```
user@switch# set protocols ospf area 0.0.0.0 interface fxp0.0 disable
user@switch# set protocols ospf area 0.0.0.0 interface ge-3/1/8.0
```

7. Configure the LDP on the loopback interface and the interfaces on which EVPN-MPLS is enabled.

```
[edit]
user@switch# set protocols ldp interface lo0.0
user@switch# set protocols ldp interface ge-3/1/5.0
user@switch# set protocols ldp interface ge-3/1/8.0
```

8. Configure a virtual switch routing instance for VLAN v100, and include the interfaces and other entities associated with the VLAN.

```
[edit]
user@switch# set routing-instances evpn1 instance-type virtual-switch
user@switch# set routing-instances evpn1 interface ge-108/0/25.0
user@switch# set routing-instances evpn1 interface ge-108/0/27.0
user@switch# set routing-instances evpn1 interface ge-3/1/9.0
user@switch# set routing-instances evpn1 route-distinguisher 10.25.0.2:1
user@switch# set routing-instances evpn1 vrf-target target:100:1
user@switch# set routing-instances evpn1 protocols evpn label-allocation per-instance
user@switch# set routing-instances evpn1 protocols evpn extended-vlan-list 100
user@switch# set routing-instances evpn1 protocols evpn mclag bgp-peer 10.25.0.1
user@switch# set routing-instances evpn1 switch-options service-id 2
user@switch# set routing-instances evpn1 vlans v100 vlan-id 100
user@switch# set routing-instances evpn1 vlans v100 l3-interface irb.0
```

PE3 Configuration

IN THIS SECTION

- [CLI Quick Configuration | 903](#)
- [PE3: Configuring EVPN-MPLS | 904](#)

CLI Quick Configuration

PE3: EVPN-MPLS Configuration

```
set interfaces lo0 unit 0 family inet address 10.25.0.3/32
set interfaces ge-0/3/5 unit 0 family inet address 10.0.1.2/30
set interfaces ge-0/3/5 unit 0 family mpls
set interfaces ge-0/3/7 unit 0 family inet address 10.0.4.1/30
set interfaces ge-0/3/7 unit 0 family mpls
set interfaces ge-0/0/46 unit 0 esi 00:01:02:03:04:00:01:02:04:12
set interfaces ge-0/0/46 unit 0 esi all-active
set interfaces ge-0/0/46 unit 0 family ethernet-switching vlan members 100
set routing-options router-id 10.25.0.3
set routing-options autonomous-system 100
set routing-options forwarding-table export evpn-pplb
set policy-options policy-statement evpn-pplb from protocol evpn
set policy-options policy-statement evpn-pplb then load-balance per-packet
set protocols mpls interface lo0.0
set protocols mpls interface ge-0/3/5.0
set protocols mpls interface ge-0/3/7.0
set protocols bgp local-address 10.25.0.3
set protocols bgp peer-as 100
set protocols bgp local-as 100
set protocols bgp group evpn-mes type internal
set protocols bgp group evpn-mes family evpn signaling
set protocols bgp group evpn-mes peer-as 100
set protocols bgp group evpn-mes neighbor 10.25.0.2
set protocols bgp group evpn-mes neighbor 10.25.0.1
set protocols ospf traffic-engineering
set protocols ospf area 0.0.0.0 interface ge-0/3/5.0
set protocols ospf area 0.0.0.0 interface lo0.0
set protocols ospf area 0.0.0.0 interface fxp0.0 disable
set protocols ospf area 0.0.0.0 interface ge-0/3/7.0
set protocols ldp interface lo0.0
set protocols ldp interface ge-0/3/5.0
set protocols ldp interface ge-0/3/7.0
set routing-instances evpn1 instance-type virtual-switch
set routing-instances evpn1 interface ge-0/0/46.0
set routing-instances evpn1 route-distinguisher 10.25.0.3:1
set routing-instances evpn1 vrf-target target:100:1
set routing-instances evpn1 protocols evpn label-allocation per-instance
set routing-instances evpn1 protocols evpn extended-vlan-list 100
```

```
set routing-instances evpn1 switch-options service-id 2
set routing-instances evpn1 vlans v100 vlan-id 100
```

PE3: Configuring EVPN-MPLS

Step-by-Step Procedure

1. Configure the interfaces on EVPN-MPLS interworking occurs.

```
[edit]
user@switch# set interfaces lo0 unit 0 family inet address 10.25.0.3/32
user@switch# set interfaces ge-0/3/5 unit 0 family inet address 10.0.1.2/30
user@switch# set interfaces ge-0/3/5 unit 0 family mpls
user@switch# set interfaces ge-0/3/7 unit 0 family inet address 10.0.4.1/30
user@switch# set interfaces ge-0/3/7 unit 0 family mpls
```

2. Configure interface ge-0/0/46 with EVPN multihoming in active-active mode, an ESI, and map the ports to VLAN v100..

```
[edit]
user@switch# set interfaces ge-0/0/46 unit 0 esi 00:01:02:03:04:00:01:02:04:12
user@switch# set interfaces ge-0/0/46 unit 0 esi all-active
user@switch# set interfaces ge-0/0/46 unit 0 family ethernet-switching vlan members 100
```

3. Assign a router ID and the autonomous system in which the PE1, PE2, and PE3 reside.

```
[edit]
user@switch# set routing-options router-id 10.25.0.2
user@switch# set routing-options autonomous-system 100
```

4. Enable per-packet load-balancing for EVPN routes when EVPN multihoming active-active mode is used.

```
[edit]
user@switch# set routing-options forwarding-table export evpn-pplb
user@switch# set policy-options policy-statement evpn-pplb from protocol evpn
user@switch# set policy-options policy-statement evpn-pplb then load-balance per-packet
```

5. Enable MPLS on the loopback interface and interfaces ge-0/3/5.0 and ge-0/3/7.0.

```
[edit]
user@switch# set protocols mpls interface lo0.0
user@switch# set protocols mpls interface ge-0/3/5.0
user@switch# set protocols mpls interface ge-0/3/7.0
```

6. Configure an IBGP overlay that includes PE1, PE2, and PE3.

```
[edit]
user@switch# set protocols bgp local-address 10.25.0.3
user@switch# set protocols bgp peer-as 100
user@switch# set protocols bgp local-as 100
user@switch# set protocols bgp group evpn-mes type internal
user@switch# set protocols bgp group evpn-mes family evpn signaling
user@switch# set protocols bgp group evpn-mes peer-as 100
user@switch# set protocols bgp group evpn-mes neighbor 10.25.0.2
user@switch# set protocols bgp group evpn-mes neighbor 10.25.0.1
```

7. Configure OSPF as the internal routing protocol for EVPN by specifying an area ID and interfaces on which EVPN-MPLS is enabled.

```
[edit]
user@switch# set protocols ospf traffic-engineering
user@switch# set protocols ospf area 0.0.0.0 interface ge-0/3/5.0
user@switch# set protocols ospf area 0.0.0.0 interface lo0.0
user@switch# set protocols ospf area 0.0.0.0 interface fxp0.0 disable
user@switch# set protocols ospf area 0.0.0.0 interface ge-0/3/7.0
```

8. Configure the LDP on the loopback interface and the interfaces on which EVPN-MPLS is enabled.

```
[edit]
user@switch# set protocols ldp interface lo0.0
user@switch# set protocols ldp interface ge-0/3/5.0
user@switch# set protocols ldp interface ge-0/3/7.0
```

9. Configure a virtual switch routing instance for VLAN v100, and include the interfaces and other entities associated with the VLAN.

```
[edit]
user@switch# set routing-instances evpn1 instance-type virtual-switch
user@switch# set routing-instances evpn1 interface ge-0/0/46.0
user@switch# set routing-instances evpn1 route-distinguisher 10.25.0.3:1
user@switch# set routing-instances evpn1 vrf-target target:100:1
user@switch# set routing-instances evpn1 protocols evpn label-allocation per-instance
user@switch# set routing-instances evpn1 protocols evpn extended-vlan-list 100
user@switch# set routing-instances evpn1 switch-options service-id 2
user@switch# set routing-instances evpn1 vlans v100 vlan-id 100
```

RELATED DOCUMENTATION

| *Understanding EVPN-MPLS Interworking with Junos Fusion Enterprise and MC-LAG*

Storm Control on a Junos Fusion Enterprise

IN THIS CHAPTER

- [Understanding Storm Control on a Junos Fusion Enterprise](#) | 907

Understanding Storm Control on a Junos Fusion Enterprise

Storm control enables the switch to monitor traffic levels and to drop broadcast, multicast, and unknown unicast packets when a specified traffic level—known as the storm control level or storm control bandwidth—is exceeded, preventing the packets from proliferating and degrading service. As an alternative to having the switch drop packets, you can configure storm control to shut down interfaces or temporarily disable interfaces when the storm control level is exceeded.

Storm control configuration in a Junos Fusion Enterprise is identical for a standalone EX9200 switch. For more information, see [Understanding Storm Control for Managing Traffic Levels on Switching Devices](#).

In a Junos Fusion Enterprise with dual aggregation devices there are special considerations that impact storm control functionality. The following requirements should be understood when configuring storm control for a Junos Fusion Enterprise:

- Broadcast, multicast, and unknown unicast packets received on the extended port of a satellite device can be forwarded to two different aggregation devices, so the storm control profile is applied to the cumulative traffic reaching a particular aggregation device, not the cumulative traffic received on the extended port of the satellite device.
- If the storm control level is exceeded and the resulting action is to shut down the port, the aggregation device which detects the storm brings down the extended port, and the status is synced to the peer aggregation device.
- The shutdown is applied at the physical interface level; in a standalone EX9200 switch, storm control shutdown is applied at the logical interface level.
- Executing the `clear ethernet-switching recovery-timeout` command on one aggregation device also clears the error on the other aggregation device.

- In the event of a shutdown, if the recovery timer is configured, the error is cleared on both aggregation devices when the timer expires.

DHCP Snooping and Port Security on a Junos Fusion Enterprise

IN THIS CHAPTER

- [Understanding Port Security Features on a Junos Fusion Enterprise | 909](#)

Understanding Port Security Features on a Junos Fusion Enterprise

Port security features help protect the access ports on your device against attacks such as address spoofing (forging) and Layer 2 denial of service. The switching device monitors DHCP messages sent from untrusted hosts and extracts their IP addresses and lease information. This information is used to build and maintain the DHCP snooping database. Only hosts that can be verified using this database are allowed access to the network.

The following port security features are supported in a Junos Fusion Enterprise:

- DHCP snooping
- DHCPv6 snooping
- Dynamic ARP inspection (DAI)
- IP source guard
- IPv6 source guard
- IPv6 neighbor discovery (ND) inspection
- IPv6 router advertisement (RA) guard

Configuration for DHCP snooping and other port security features in a Junos Fusion Enterprise is identical for a standalone EX9200 switch. The range of port security configuration options are beyond the scope of this document. For additional information, see [Configuring Port Security Features](#) and the [Port Security User Guide for EX9200 Switches](#).

In a Junos Fusion Enterprise with dual aggregation devices, there are special considerations that impact the DHCP snooping database. The following requirements should be understood when configuring DHCP port security features for a Junos Fusion Enterprise:

- The DHCP snooping database is synchronized across aggregation devices. Synchronization is automatic for all dual-homed clients; there is no manual configuration required to sync the DHCP snooping database.

NOTE: DHCP relay and DHCP server bindings are not synchronized.

- DAI and ND inspection statistics are synchronized on both aggregation devices.
- DHCP port security configuration must match on both aggregation devices, so DHCP port security features should be configured using configuration groups that are applied to both aggregation devices using commit synchronization. See "[Understanding Configuration Synchronization in a Junos Fusion](#)" on page 28 and "[Enabling Configuration Synchronization Between Aggregation Devices in a Junos Fusion](#)" on page 89.
- Executing the `clear dhcp-security binding` command on one aggregation device also clears the bindings on the other aggregation device.
- DHCP port security features are not supported for single-homed clients in a dual-aggregation device topology, since the DHCP snooping database is synchronized only for dual-homed clients.

MAC Limiting and Persistent MAC Learning on a Junos Fusion Enterprise

IN THIS CHAPTER

- [Understanding MAC Address Limiting and Persistent MAC Learning on a Junos Fusion Enterprise | 911](#)

Understanding MAC Address Limiting and Persistent MAC Learning on a Junos Fusion Enterprise

IN THIS SECTION

- [MAC Address Limiting on a Junos Fusion Enterprise | 912](#)
- [Persistent MAC Learning on a Junos Fusion Enterprise | 912](#)

MAC limiting enhances port security by limiting the number of MAC addresses that can be learned within a VLAN, which prevents flooding of the Ethernet switching table. You can configure MAC limiting to drop packets or to shut down interfaces when the MAC limit is exceeded.

Persistent MAC learning—also called sticky MAC addresses—enables an interface to retain dynamically learned MAC addresses when the switch is restarted or if the interface goes down and is brought back online, preventing traffic loss for trusted workstations.

MAC limiting and persistent MAC learning configuration in a Junos Fusion Enterprise is identical for a standalone EX9200 switch. For more information on MAC limiting, see [Understanding MAC Limiting](#). For more information on persistent MAC learning, see [Understanding Persistent MAC Learning \(Sticky MAC\)](#).

In a Junos Fusion Enterprise, there are special considerations that impact MAC limiting and persistent MAC learning functionality.

MAC Address Limiting on a Junos Fusion Enterprise

The following actions are possible when the MAC limit is reached on an interface:

- None—No impact on functionality of the aggregation device or the satellite device. Traffic is forwarded from the satellite device to the aggregation device.
- Shutdown—The extended port on the satellite device is shutdown when the MAC limit is reached on the aggregation device.
- Drop—The unlearned source MAC packet is forwarded by the satellite device and dropped on the aggregation device.

The following requirements should be understood when configuring MAC address limiting for a Junos Fusion Enterprise with dual aggregation devices:

- There is the potential for MAC addresses received on an extended port to be forwarded to different aggregation devices. To prevent inconsistency, the learned MAC addresses are synchronized across both aggregation devices. If one aggregation device is not able to install a MAC address due to MAC limiting, that MAC address is deleted from the peer aggregation device.
- For the shutdown action, the shutdown on extended ports is applied at the physical interface level; in a standalone EX9200 switch, MAC limiting shutdown is applied at the logical interface level.
- Executing the `clear ethernet-switching recovery-timeout` command on one aggregation device also clears the error on the other aggregation device.
- In the event of a shutdown, if the recovery timer is configured, the error is cleared on both aggregation devices when the timer expires.

Persistent MAC Learning on a Junos Fusion Enterprise

The following requirements should be understood when configuring persistent MAC learning for a Junos Fusion Enterprise with dual aggregation devices:

- MAC addresses learnt locally or remotely are treated as persistent entries and saved in the persistent file on both aggregation devices.
- Persistent MAC learning cannot be enabled on the ICL interface. This is enforced by commit check.
- When persistent MAC learning is configured on extended ports of a single-homed satellite device, MAC addresses learned locally are learned as persistent addresses, and MAC addresses learned on the peer are learned as remote dynamic addresses.
- Clearing the `persistent-mac` on one aggregation device also deletes the entry from other aggregation device.

If you move a device within your network that has a persistent MAC address entry on the switch, use the `clear ethernet-switching table persistent-mac` command to clear the persistent MAC address entry from the interface. If you move the device and do not clear the persistent MAC address from the original port on which it was learned, then the new port will not learn the MAC address of the device and the device will not be able to connect.

If the original port is down when you move the device, then the new port will learn the MAC address and the device can connect. However, if you do not clear the persistent MAC address on the original port, then when the port restarts, the system reinstalls the persistent MAC address in the forwarding table for that port. If this occurs, the persistent MAC address is removed from the new port and the device loses connectivity.